

Champion®

Installation/Operation with Service Replacement Parts

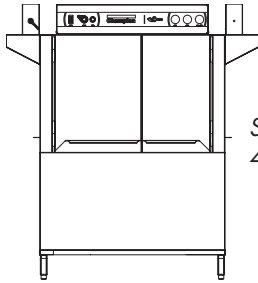

Single Tank Dual Rinse
44" Model 44DR

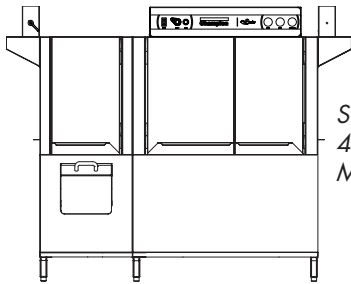

Single Tank Dual Rinse
44" with 22" Prewash
Model 66DRPW

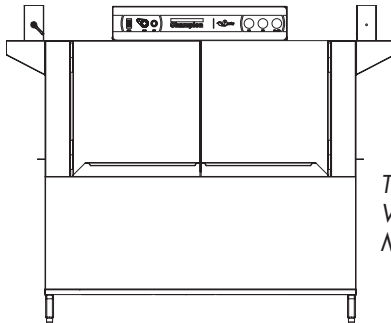

Two Tank 64"
Wash and Power Rinse
Model 64

E-series Rack Conveyor Dishwashers (with swing-out doors)

Models

Single Tank Dual Rinse	Two Tank
44DR	64
66DRPW	86PW
70DRFFPW	90FFPW
80DRHDPW	100HDPW
54DR	84
76DRPW	106PW
80DRFFPW	110FFPW
90DRHDPW	120HDPW



www.championindustries.com

Issue Date: 12.12.16

Manual P/N 115328 rev. D

For machines beginning with S/N RE13077060 and above

3765 Champion Boulevard
Winston-Salem, NC 27105
(336) 661-1556 Fax: (336) 661-1660
Toll-free: 1 (800) 858-4477

2674 N. Service Road, Jordan Station
Ontario, Canada L0R 1S0
(905) 562-4195 Fax: (905) 562-4618
Toll-free: 1 (800) 263-5798

Printed in USA



Champion Industries,
an Ali Group Company

For future reference, record your dishwasher information in the box below.

Model Number_____	Serial Number_____	
Voltage_____	Hertz_____	Phase_____
Champion Service Agent _____	Tel:_____	
Champion Parts Distributor _____	Tel:_____	

National Service Department



In Canada:

Toll-free: 1 (800) 263-5798
Tel: (905) 562-4195
Fax: (905) 562-4618
email: service@moyerdiebellimited.com



In the USA:

Toll-free: 1 (800) 858-4477
Tel: (336) 661-1556
Fax: (336) 661-1660
email: service@championindustries.com

ATTENTION:

The dishwasher model number, serial number, voltage, hertz and phase are needed to identify your machine and to answer questions.

Please have this information on-hand if you call for service assistance.

For all models:

The data plate mounts to one side of the top-mounted control cabinet.

REGISTER YOUR PRODUCT ONLINE

Make sure you are connected to the internet then enter an address below:

In the U.S.A.

<http://www.championindustries.com/register>

In Canada

<http://www.championindustries.com/canada/register>

Champion[®]

PRODUCT REGISTRATION BY FAX

COMPLETE THIS FORM AND FAX TO:

(336) 661-1660 in the USA

1 (800) 204-0109 in Canada

PRODUCT REGISTRATION CARD

Model

Serial #

Date of Installation: ___/___/___

Company Name: _____

Address: _____

(Street)

State

Zip or

Telephone #: () _____ --- _____

or Province

Postal Code

Contact: _____

Installation Company: _____

Address: _____

Telephone #: _____

Contact: _____

FAILURE TO REGISTER YOUR PRODUCT MAY VOID YOUR WARRANTY

IMPORTANT IMPORTANT

Revision History

A revision might be a part number change, new instructions, or information that was not available at print time. We reserve the right to make changes to this manual without notice and without incurring any liability by making the changes. Dishwasher owners may request a revised manual, at no charge, by calling 1 (800) 858-4477 in the USA or 1 (800) 263-5798 in Canada.

Revision Date	Revised Pages	Serial Number Effectivity	Description
9.11.13	All	RE13077060	Released First Edition
7.14.15	60-63, 124-129	RE150607977	Revised images and Parts List for Doors and Screens
7.14.15	All	–	Reviewed and Revised Manual
4.27.16	98-99	All	Reversed Items 5 and 8
5.19.16	33	All	Removed Arc Suppressor, P/N 114934, from Control Cabinet Assembly
12.12.16	57	All	Changed the Cradle P/N to 415667

Limited Warranty

LIMITED WARRANTY

Champion Industries Inc. (herein referred to as Champion), 3765 Champion Blvd., Winston-Salem, North Carolina 27105 and 2674 N. Service Road, Jordan Station, Canada, L0R 1S0, warrants machines, and parts, as set out below.

Warranty of Machines: Champion warrants all new machines of its manufacture bearing the name "Champion" and installed within the United States and Canada to be free from defects in material and workmanship for a period of one (1) year after the date of installation or fifteen (15) months after the date of shipment by Champion, whichever occurs first. [See below for special provisions relating to glasswashers.] Warranty registration must be returned to Champion within ten (10) days after installation either online on the Champion Industries website (<http://www.championindustries.com/register>) in the USA or <http://www.championindustries.com/canada/register> in Canada or by fax on the form provided at the front of this manual. If warranty registration is not returned to Champion within such period, the warranty will expire after one year from the date of shipment. Champion will not assume any responsibility for extra costs for installation in any area where there are jurisdictional problems with local trades or unions. If a defect in workmanship or material is found to exist within the warranty period, Champion, at its election, will either repair or replace the defective machine or accept return of the machine for full credit; provided; however, as to glasswashers, Champion's obligation with respect to labor associated with any repairs shall end (a) 120 days after shipment, or (b) 90 days after installation, whichever occurs first. In the event that Champion elects to repair, the labor and work to be performed in connection with the warranty shall be done during regular working hours by a Champion authorized service technician. Defective parts become the property of Champion. Use of replacement parts not authorized by Champion will relieve Champion of all further liability in connection with its warranty. In no event will Champion's warranty obligation exceed Champion's charge for the machine. The following are not covered by Champion's warranty:

- a. Lighting of gas pilots or burners.
- b. Cleaning of gas lines.
- c. Replacement of fuses or resetting of overload breakers.
- d. Adjustment of thermostats.
- e. Adjustment of clutches.
- f. Opening or closing of utility supply valves or switching of electrical supply current.
- g. Cleaning of valves, strainers, screens, nozzles, or spray pipes.
- h. Performance of regular maintenance and cleaning as outlined in operator's guide.
- i. Damages resulting from water conditions, accidents, alterations, improper use, abuse, tampering, improper installation, or failure to follow maintenance and operation procedures.
- j. Wear on Pulper cutter blocks, pulse vanes, and auger brush.

Examples of the defects not covered by warranty include, but are not limited to: (1) Damage to the exterior or interior finish as a result of the above, (2) Use with utility service other than that designated on the rating plate, (3) Improper connection to utility service, (4) Inadequate or excessive water pressure, (5) Corrosion from chemicals dispensed in excess of recommended concentrations, (6) Failure of electrical components due to connection of chemical dispensing equipment installed by others, (7) Leaks or damage resulting from such leaks caused by the installer, including those at machine table connections or by connection of chemical dispensing equipment installed by others, (8) Failure to comply with local building codes, (9) Damage caused by labor dispute.

Warranty of Parts: Champion warrants all new machine parts produced or authorized by Champion to be free from defects in material and workmanship for a period of 90 days from date of invoice. If any defect in material and workmanship is found to exist within the warranty period Champion will replace the defective part without charge.

DISCLAIMER OF WARRANTIES AND LIMITATIONS OF LIABILITY. CHAMPION'S WARRANTY IS ONLY TO THE EXTENT REFLECTED ABOVE. CHAMPION MAKES NO OTHER WARRANTIES, EXPRESS OR IMPLIED, INCLUDING, BUT NOT LIMITED, TO ANY WARRANTY OF MERCHANTABILITY, OR FITNESS OF PURPOSE. CHAMPION SHALL NOT BE LIABLE FOR INCIDENTAL OR CONSEQUENTIAL DAMAGES. THE REMEDIES SET OUT ABOVE ARE THE EXCLUSIVE REMEDIES FOR ANY DEFECTS FOUND TO EXIST IN CHAMPION DISHWASHING MACHINES AND CHAMPION PARTS, AND ALL OTHER REMEDIES ARE EXCLUDED, INCLUDING ANY LIABILITY FOR INCIDENTALS OR CONSEQUENTIAL DAMAGES.

Champion does not authorize any other person, including persons who deal in Champion dishwashing machines to change this warranty or create any other obligation in connection with Champion Dishwashing Machines.

Table of Contents

E-series Rack Conveyor Dishwashers

Revision History	i
Limited Warranty	ii
Model Descriptions.....	iv

Installation..... 1

<i>Installation Codes, Warranty Registration, Receiving</i>	1
<i>Table Connections</i>	2
<i>Utilities, Hot and Cold Water Connections</i>	3
<i>Drain Connections, Steam Supply and Condensate Connections</i>	4
<i>Ventilation Guidelines</i>	4
<i>Electrical Connections</i>	5
<i>Optional Table Limit Switch</i>	7
<i>Chemical Connections, Vent Fan Signal Connections</i>	8
<i>Machine Running and Table Limit Switch Signal Connections</i>	9
<i>Curtain Locations</i>	10
<i>Hot Water Coil Tank Heat, Air Purging Instructions</i>	11
<i>Door Safety Switches</i>	13
<i>Removing and Installing Spray Arms and Scrap Screens</i>	14
<i>Installation Checklist</i>	18

Operation 19

<i>Operation</i>	19
<i>Door Safety Switches</i>	20
<i>Scrap Screens</i>	22
<i>Cleaning and Maintenance</i>	23
<i>E-Rack Digital Temperature Display Meters (Operation and Calibration)</i>	26
<i>Troubleshooting</i>	30

Service Replacement Parts 31

Electrical Schematics 147

Control Circuit Board Diagnostics 157

Model Descriptions

Model Descriptions

Champion's single tank and two tank rack conveyor dishwashers are fully automatic. Standard equipment includes 1HP prewash, 2HP wash and 2HP power rinse pumps.

The conveyor drive is a 1/6 HP motor. All models are available in right-to-left (R-L) or left-to-right (L-R) direction.

Model Numbers

Single Tank - Basic (dual rinse).....	44DR, 54DR
Single Tank with 22" Prewash (dual rinse).....	66DRPW, 76DRPW
Single Tank with 36" Prewash	80DRHDPW, 90DRHDPW
Single Tank with 26" Front Feed Prewash	70DRFFPW, 80DRFFPW

Dual-Rinse (DR) models feature a recirculating rinse that conserves energy.

The 44 DR and 54 DR basic models are high temperature 180°F/80°C hot final rinse water sanitizing dishwashers. Prewash options are available in 22", 36", and 26" front feed. Built-in stainless steel electric booster heaters in 40°F/22°C and 70°F/39°C rise are available and steam booster heaters in 40°F/22°C and 70°F/39°C rise.

Two Tank - Basic	64, 84
Two Tank with 22" Prewash.....	86PW, 106PW
Two Tank with 36" Prewash.....	100HDPW, 120HDPW
Two Tank with 26" Front Feed Prewash.....	90FFPW, 110 FFPW

The 64, and 84 basic models are high temperature 180°F/80°C hot water final rinse sanitizing models. Prewash options are available in 22", 36", and 26" front feed.

Built-in stainless steel electric booster heaters in 40°F/22°C and 70°F/39°C rise are available and steam booster heaters in 40°F/22°C and 70°F/39°C rise.

All rack conveyor dishwasher models are covered by a 1-year parts and labor limited warranty.

! ATTENTION !

The installation, and initial start-up of your dishwasher must be performed by qualified electricians, plumbers, and authorized service technicians trained in commercial dishwashers.

Defects and repairs caused by unauthorized installers will not be covered by the limited dishwasher warranty.

Installation Codes

The installation of the dishwasher must comply with all local electrical, plumbing, health and safety codes or in the absence of local codes, installed in accordance with the applicable requirements in the National Electrical Code, ANSI/NFPA 70 (latest edition), CAN/CSA B149.1 and the Canadian Electrical Code (CEC), Part 1, CSA C22.1 (latest edition); and the Standard for Ventilation Control and Fire Protection of Commercial Cooking Operations, NFPA 96.

Warranty Registration

Warranty registration must be submitted to Champion within ten (10) days after installation either online on the Champion Industries website (<http://www.championindustries.com/register>) in the USA or <http://www.championindustries.com/canada/register> in Canada or by fax on the form provided at the front of this manual. If warranty registration is not returned to Champion within such period, the warranty will expire after one year from the date of shipment.

Receiving

CAUTION:

Be careful when moving or lifting the dishwasher to prevent damaging the dishwasher or the installation site. Check doorway and passageway clearance before moving the dishwasher. Remove dishwasher front panels and check under the machine base for obstructions before moving.

1. Inspect the dishwasher for shipping damage
2. Check the dishwasher interior for curtains, panels and other supplies.
3. Lift the dishwasher off the shipping pallet and move the machine near its permanent location.
4. Leave a minimum of 6" between walls and the rear of the dishwasher.
5. Level the dishwasher side-to-side and front-to-back using a bubble level.
The dishwasher legs are adjusted by screwing them in or out.
6. Do not remove tags attached to the utility connections until the installation is complete.
7. Remove the protective film from the dishwasher exterior.
8. Remove any foreign material from the dishwasher interior.

Installation

Table Connections

The dishwasher and dish tables must be in their final locations and level before connection. The recommended table height is 34"/864mm.

1. Slope the load end dish table away from the entrance of the dishwasher to prevent water from flowing into the dishwasher.
2. Slope the unload end dish table toward from the exit of the dishwasher so that water flows back into the dishwasher.
3. The dish table flanges should be bolted and sealed to the ends of the dishwasher using a food-grade silicon sealant as shown in the table connection detail illustration below.

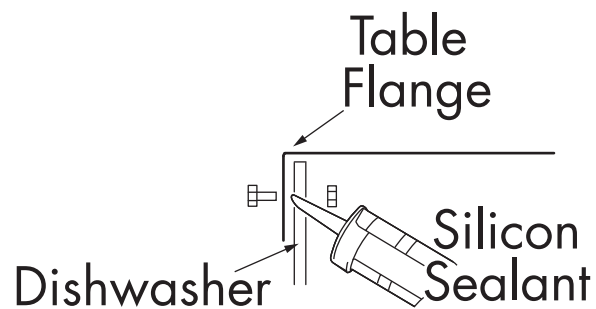
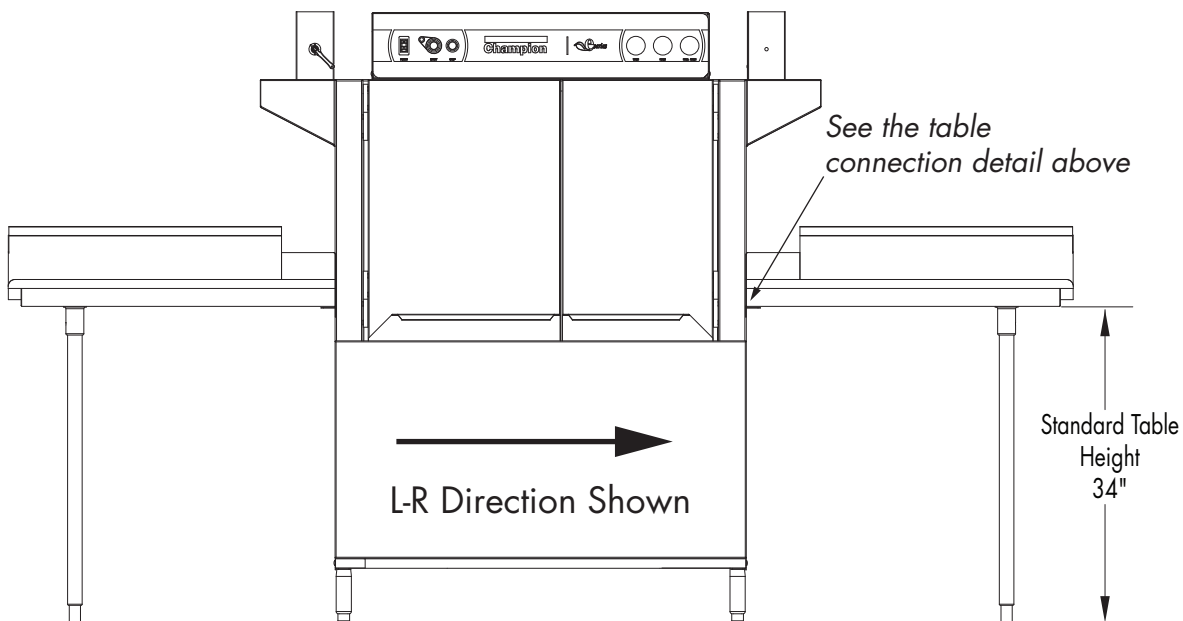

Table connection detail



Typical table installation

NOTE:

Only qualified personnel should make dishwasher plumbing connections. Connections must meet local plumbing and sanitary codes. Improper installation is not covered by the dishwasher warranty.

Hot Water Requirements:

1. A water hardness of 3 grains/U.S. gal [51.3 mg/L] or less is recommended.
2. Connect a 3/4" NPT hot water supply line to the line strainer located at the top rear of the dishwasher.
3. For a dishwasher without a booster heater, the hot water connection must supply a minimum of 180°F/82°C measured at the dishwasher.
4. For a 40°F/22°C rise booster heater, the hot water connection must supply a minimum of 140°F/60°C measured at the dishwasher.
5. For a 70°F/39°C rise booster heater, the hot water connection must supply a minimum of 110°F/43°C measured at the dishwasher.
6. For a single wash tank hot water coil heated dishwasher, the hot water connection must supply a minimum of 185°F/85°C measured at the dishwasher.
7. For a two-tank hot water coil heated dishwasher, the hot water connection must supply a minimum of 195°F/91°C measured at the dishwasher.
8. Install a pressure regulating valve (PRV) before the dishwasher supply connection to maintain a flowing pressure of 20-25 PSI
9. Install a service shut-off valve in the supply line, as close to the dishwasher as possible. The size of the valve must be the same size or larger than the supply line.

Cold Water Connections

Cold Water Requirements:

1. A water hardness of 3 grains/U.S. gal [51.3 mg/L] or less is recommended.
2. Connect a 1/2" NPT cold water supply line for a dishwasher equipped with a prewash cold water tempering option. Connection is located at the top of rear of the dishwasher load end.
3. Connect a 1/2" NPT cold water supply line for dishwashers required to have a drain water temperature tempering option. Request a drain tempering water kit (P/N 452891).

Installation

Drain Connections

1. The 1-1/2" drain line was removed and packed inside the dishwasher prior to shipping. Install the drain line once the dishwasher has been placed in its final location.
2. Connect the 1-1/2" NPT drain line above a drain sink or to a 1-1/2" or larger drain line connection.
3. Observe all local plumbing and sanitary codes when installing.

Steam Supply and Condensate Connections

1. Check the steam pressure requirements prior to connecting the steam supply lines.
The high pressure steam supply is 15-30 PSI/103-201 kPa.
The steam supply line must be a 1-1/4" NPT line with a 3/4" NPT condensate return.
2. Low pressure steam supply is 7-14 PSI/48.2-96.5 kPa.
The steam supply line must be a 2" NPT line with a 1" NPT condensate return.
3. Connect a steam supply line the same size or larger to the dishwasher at the steam supply strainer located at the unload end of the dishwasher.
4. Condensate lines must be gravity drain with no back pressure. A condensate lift pump must be installed if the condensate flow is above the finished floor.

Ventilation Connections

1. DO NOT VENT THE DISHWASHER INTO WALLS, CEILINGS OR ENCLOSED PLACES.
2. Vent stacks with adjustable dampers are supplied with the dishwasher to connect house vent.
3. Connect stainless steel water-tight duct inside the 4" x 16"/106mm x 407mm vent stacks supplied with the dishwasher.
4. A minimum of 6 air changes per hour of kitchen is recommended

Ventilation Guidelines:

Dishwasher without a prewash tank option:

Load end- 200 CFM @ 1/4" SP/ 95 Liters/second

Unload end- 400 CFM @ 1/4" SP/ 189 Liters/second

Dishwasher with a Prewash tank option:

Load end- 150 CFM @ 1/4" SP/ 95 Liters/second

Unload end- 400 CFM @ 1/4" SP/ 189 Liters/second

Dishwashers with more than two tanks:

Load end- 200 CFM @ 1/4" SP/ 95 Liters/second

Unload end- 400 CFM @ 1/4" SP/ 189 Liters/second

Electrical Connections

**WARNING:**

Electrocution or serious injury may result when working on an energized circuit.

Disconnect power at the main breaker or service disconnect switch before working on the circuit.

Lock-out and tag the breaker to indicate that work is being performed on the circuit.

! ATTENTION !

A qualified electrician must connect the main incoming power to the dishwasher in accordance with all local codes and regulations or in the absence of local codes in accordance with the National Electrical Code.

! ATTENTION !

Electrical and grounding connections must comply with the National Electrical Code or in the absence of a National Code then all Local Electrical Codes.

A qualified electrician **MUST** compare the electrical power supply with the machine electrical specifications stamped on the MACHINE ELECTRICAL CONNECTION PLATE located inside the control cabinet before connecting the main power to the dishwasher.

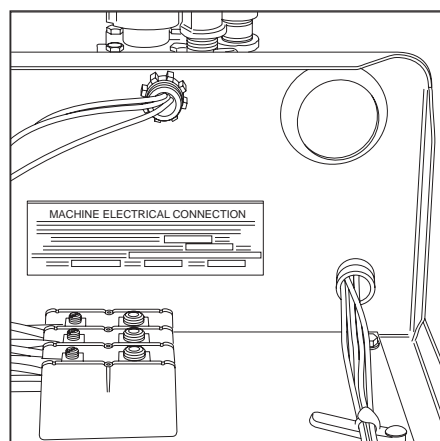

1. The incoming power to the dishwasher is made in the power terminal block, located inside the top-mounted control cabinet.
2. The electrician must connect the incoming power based on the information that is stamped on the Machine Electrical Connection Plate.
3. Any change to the Machine Electrical Connection Plate must be approved by the factory in advance.
4. A knock-out plug is provided at the rear of the control cabinet for electrical service connections.
5. Built-in electric booster heaters may have a separate main power connection.
6. Electric blower-dryers have a separate main power connection.

Installation

Electrical Connections (continued)

Motor Rotation

1. Check the conveyer drive motor to ensure it rotates in the correct direction. The motor shaft must rotate in a counterclockwise direction when viewed from the rear.
2. The dishwasher motors are phased together; therefore, if the conveyer motor rotation is correct then the pump motors will also be correct.
3. If the conveyer motor rotation is not correct, then reverse the L1 and L2 wires on the output side of the dishwasher main terminal block located inside the top-mounted control cabinet. Check to ensure the conveyer motor rotates counterclockwise after reversing the wires.

NOTE:

The prewash, wash and rinse pump motor shafts rotate clockwise when viewed from the rear. In addition, the motors have direction arrow labels indicating the proper rotations.

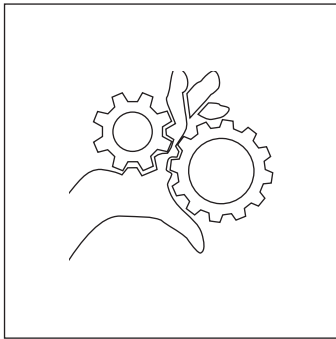

WARNING:

Moving Conveyor Parts may cause INJURY OR DEATH.
Keep hands and clothing clear of the conveyor when the conveyor is moving.

USE EXTREME CAUTION WHEN THE CONVEYOR IS MOVING.

THREE PHASE POWER CONNECTION

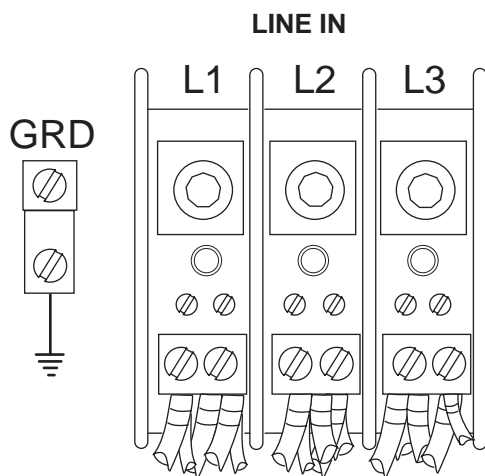

Main Terminal Block Inside the Top-mounted Control Cabinet.

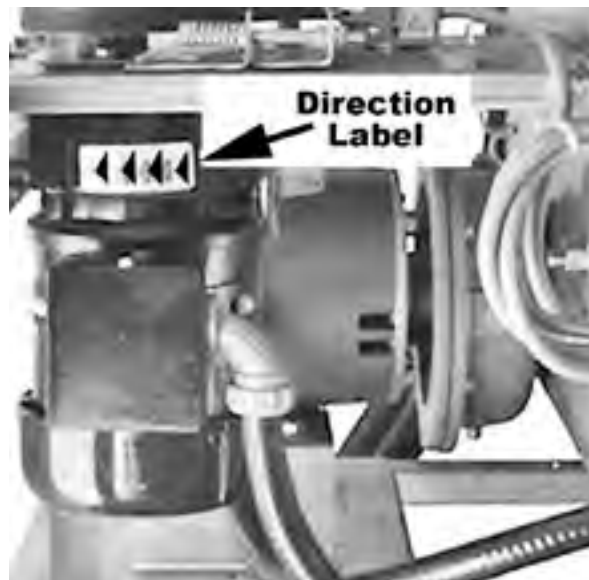

Motor Direction Rotation Label on Motor Frame.

(Optional) Table Limit Switch

A recommended option for any rack conveyor dishwasher is a table limit switch. The limit switch is installed at the end of the clean-end table and is designed to stop the conveyor and pumps in the event that dish racks back up on the clean-end table. This feature prevents possible damage to the conveyor due to jamming. The operation of the table limit switch is described below.

1. If the dishwasher is running and the table limit switch (TLS) is activated, the GREEN cycle light remains illuminated and the pumps and conveyor drive stop.
2. If the table limit switch (TLS) is deactivated within 5 minutes the dishwasher will resume the cycle where it left off; after 5 minutes the green light goes out and the START button must be pushed and a rack inserted into the machine.
3. Any dish racks left in the machine after 5 minutes have elapsed must be removed and processed again.
4. To restart the dishwasher, make sure the table limit switch (TLS) is clear, then push the GREEN START pushbutton and insert a rack into the load end of the machine. The green cycle light will illuminate; the pumps and conveyor motor will run.

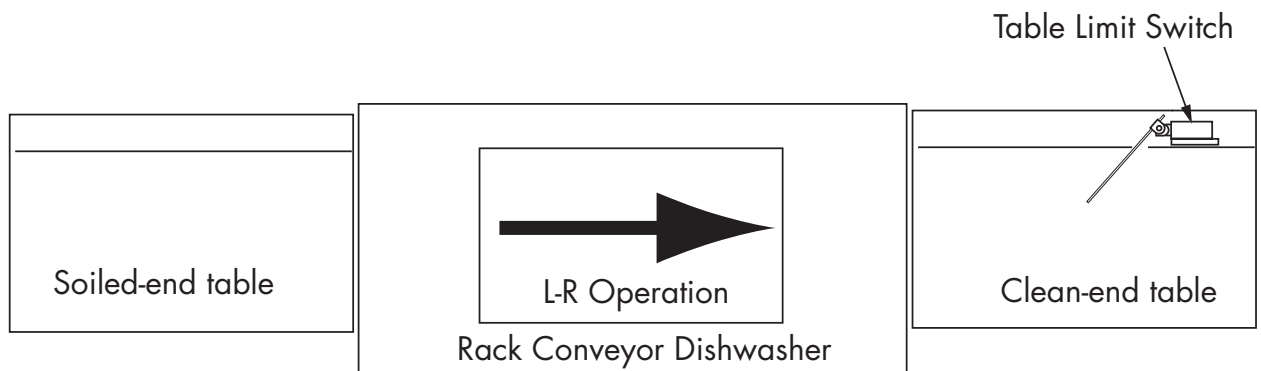

Installation

Chemical Connections

1. Use a qualified detergent/chemical supplier for detergent/chemical and dispensing equipment needs.
2. Labeled detergent control circuit connection terminals are provided in the control cabinet for detergent and rinse agent/sanitizer dispensing equipment (supplied by others).
3. The illustration on the right, shows the terminal board for the machine.
4. The signal connection points include:
 - Detergent signal 120VAC, 1A max load.
 - Rinse aid/Sanitizer signal 120VAC, 1A load.
 - Vent Fan 120VAC, 1Amp max amp load
5. A removable black plug is provided in the load end side of the wash tank for installation of the detergent conductivity cell.

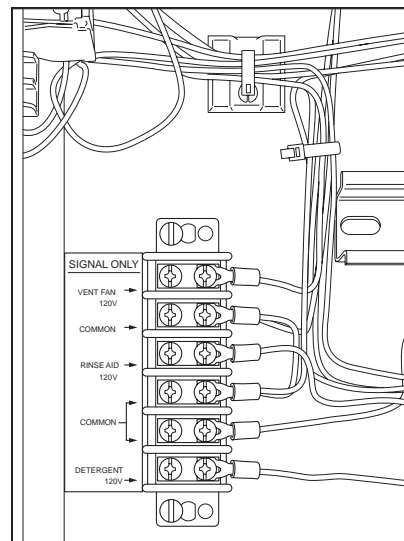
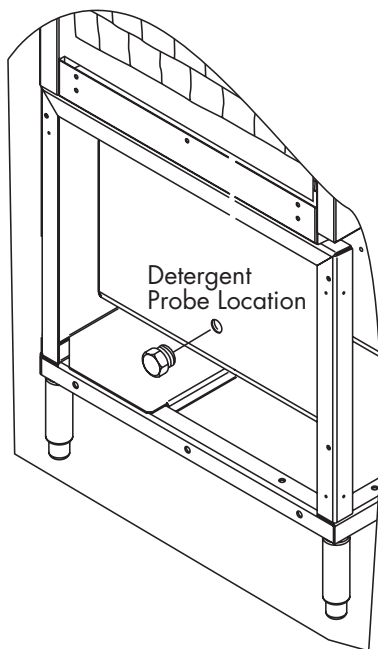

Vent Fan Signal Connection

1. A terminal block is provided inside the top-mounted control cabinet to provide a 120VAC, 1 AMP Max Load signal.

NOTE:

The Vent Fan Signal Connection supplies 120VAC to a control relay (supplied by others) when the dishwasher is ON and 0 VAC when the dishwasher is OFF. Power to operate the vent fan (supplied by others) must be supplied separately.

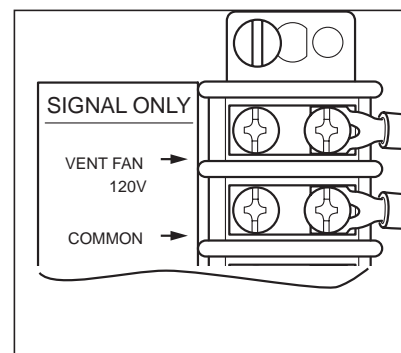

Machine Running & Table Limit Switch Signal Connections

1. Connections are provided for systems that require a signal to indicate the dishwasher is running.
2. A signal connection is provided to indicate that the dishwasher has stopped due to a conveyor jam or when the clean dish table is full of racks and additional racks cannot exit the machine.
3. The table limit switch option is recommended to be installed on all dishwashers and can be ordered from the factory P/N 407400.

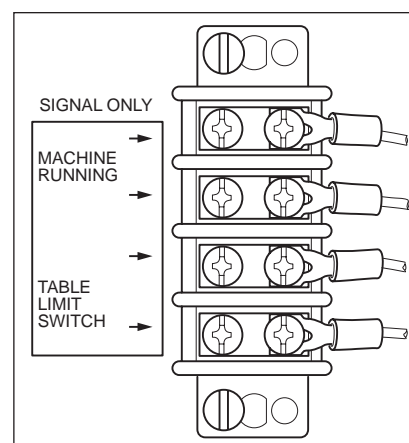

Installation

Curtain Locations

1. Refer to the illustrations below and hang the curtains as shown. J-hooks are located in the corners of each section to accept the curtain rods.
 - Standard long curtains 24" x 20-1/4"
 - High hood long curtains 24" x 22-3/4"
 - Standard medium curtains and DR 24" x 13-1/4"
 - High hood short curtains 24" x 20-1/4"
 - Final rinse curtain 24" x 6-1/4"
2. Make sure that the short flaps of the curtains face the load end of the dishwasher. The long curtains always go on each end of the dishwasher.

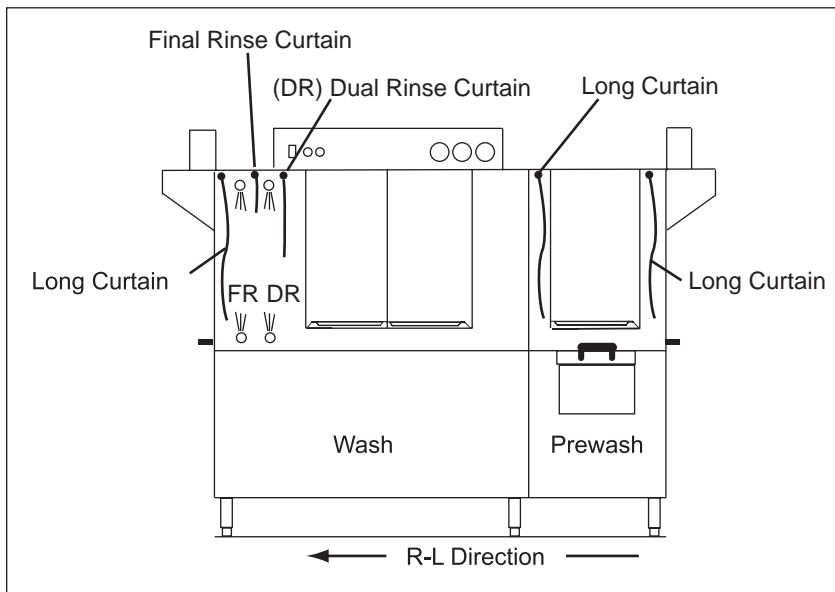

Dual Rinse Single Tank Dishwasher with Prewash Curtains.

NOTE:
Misplacing a curtain or failing to install a curtain will adversely affect the proper operation of the machine.

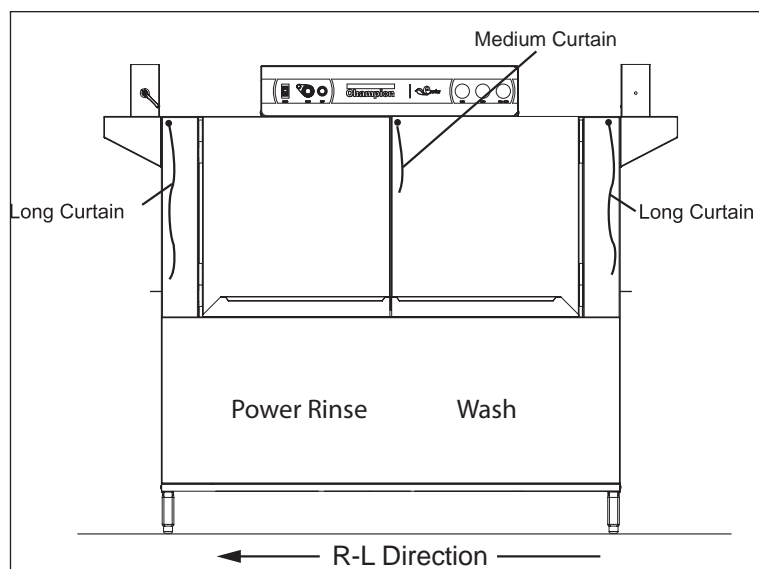

Two Tank Dishwasher Curtain Locations

Hot Water Coil Tank Heat Purging Air from the Dishwasher/Booster Heater System

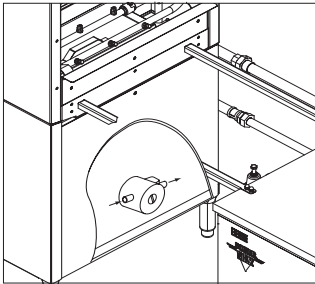

CAUTION:

PERMANENT DAMAGE to the hot water recirculating pump can occur if the air is not purged from the dishwasher/booster heater system prior to placing the dishwasher into service.

Follow the instructions on pages 9-10 to prevent damage to the dishwasher hot water recirculating pump.

The air trapped in the Dishwasher Hot Water Recirculating Pump and Water Lines must be purged. Refer to the illustration below and follow the procedure on the next page.

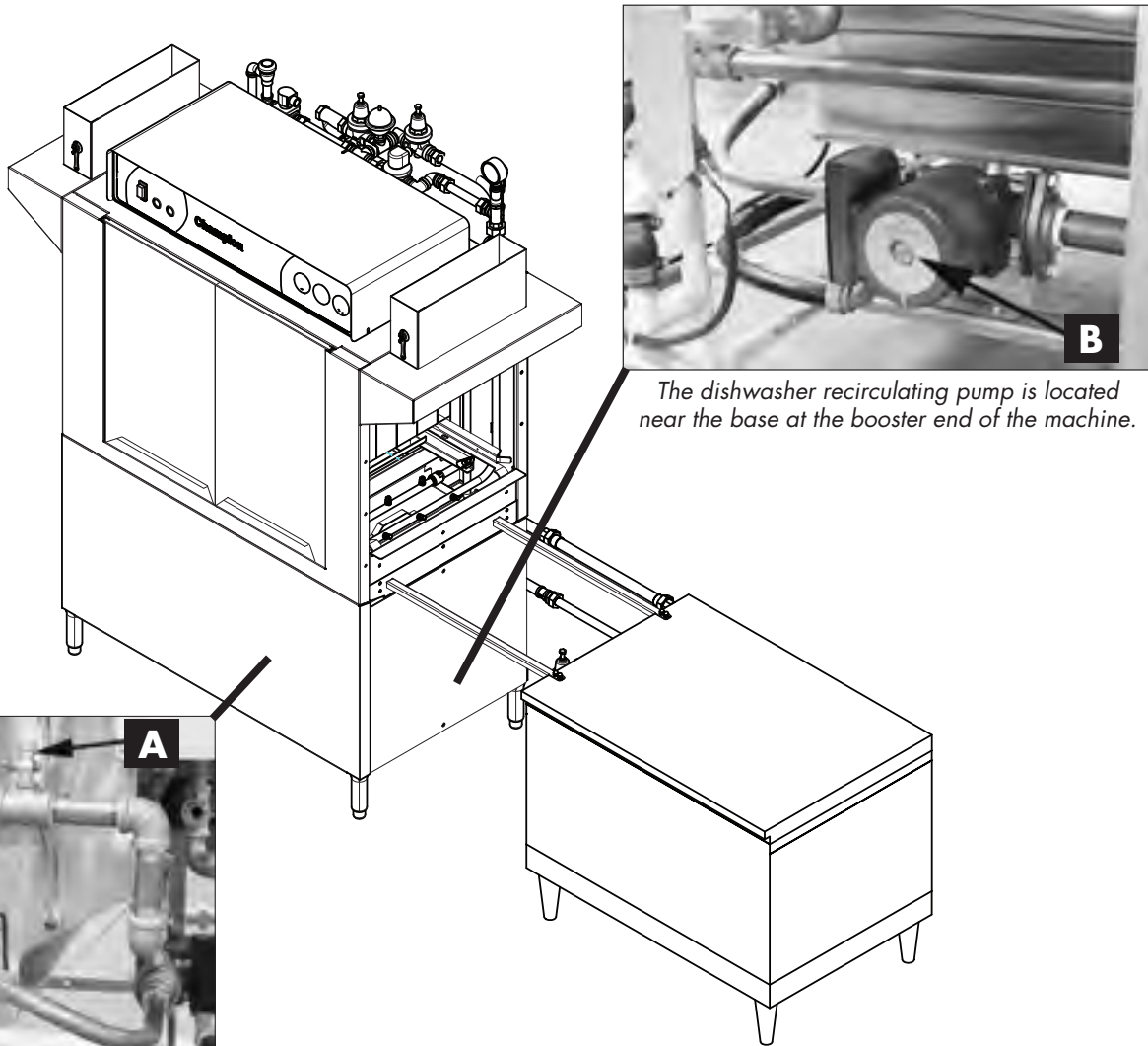

The dishwasher recirculating pump is located near the base at the booster end of the machine.

The air purge petcock is located behind the dishwasher lower front panel at the booster end of the machine.

Installation

Hot Water Coil Tank Heat

Purging Air from the Dishwasher/Booster Heater System (continued)

Refer to the illustration on the previous page and follow the procedure below to purge the air from the system. Plumbing and electrical service connections must be completed before purging the system.

To purge the air:

1. Make sure the dishwasher main power switch is OFF.
2. Make sure the main water supply valve located at the booster heater is OFF.
3. Open petcock (A) on the inlet side of the dishwasher hot water heater coil.
4. Remove the silver plug located in the center of the recirculating pump.
5. Turn the main water supply valve ON. Water will begin to fill the booster heater and the dishwasher heater coil.
6. Water and air will begin to flow out of the purge petcock and the recirculating pump and eventually only water will be observed.
7. Turn the booster heater power switch ON.
8. Turn the dishwasher power switch ON. The dishwasher wash tank will begin to fill with water.
9. Continue to observe the petcock and the recirculating pump and make sure that there is a steady stream of water is flowing from (A) and (B).
10. Replace the silver plug (B) in the center of the recirculating pump then close the petcock (A).
11. Turn the dishwasher power switch OFF.
12. Purging is complete.

Door Safety Switches

Dishwasher access doors are equipped with a door safety switch that automatically stops the dishwasher pumps and conveyor drive if a door is raised while the dishwasher is running. In addition, the dishwasher will not start if a door is left open.

1. If the dishwasher is running and a door is raised, the lighted GREEN START pushbutton goes out and the pumps and conveyor drive stop.
2. Check the interior of the dishwasher for any dish racks still in the machine. These dish racks must be washed again to ensure they are washed and sanitized completely.
3. To restart the dishwasher, make sure all doors are closed, then push the GREEN START pushbutton.

Spray Arm and Scrap Screen Installation

The illustrations below and on the following pages illustrate how to install and remove the spray arm assemblies and scrap screens.

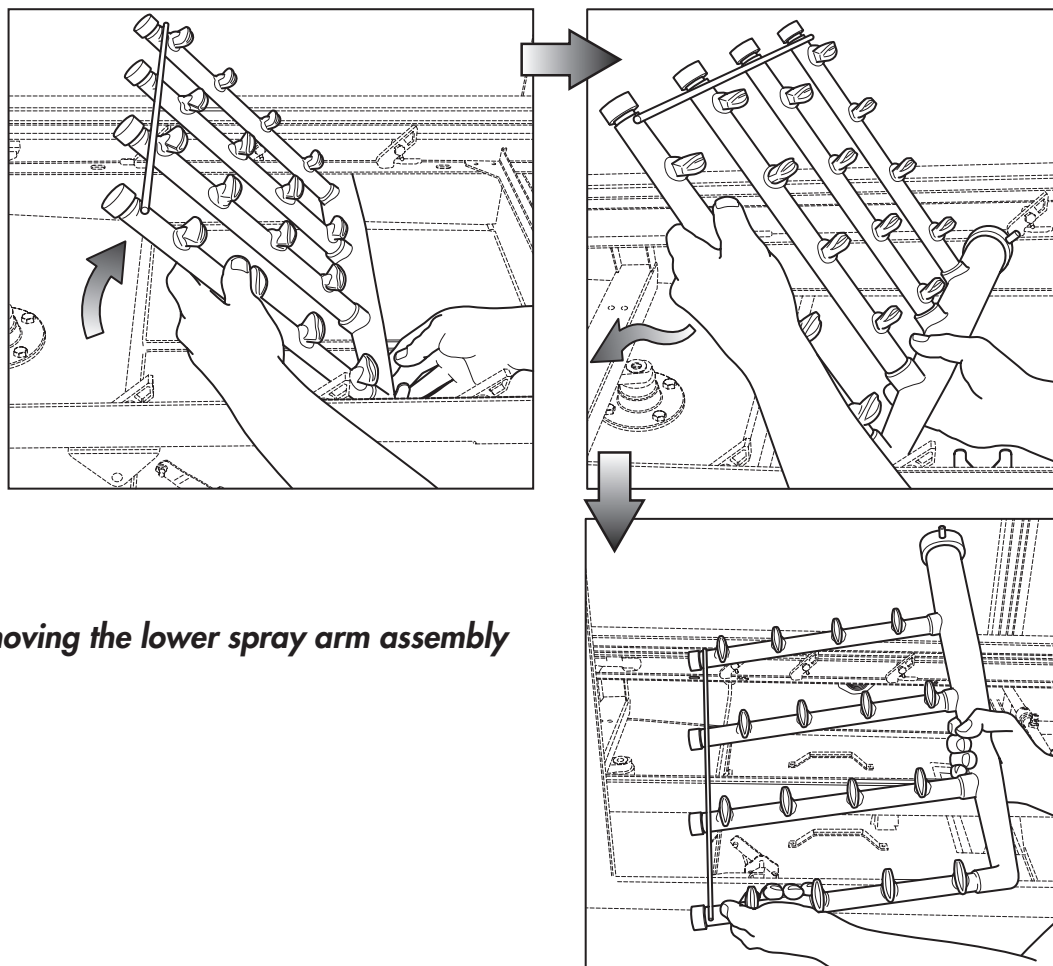

Removing the lower spray arm assembly

Installation

Removing the Spray Arm End Plugs

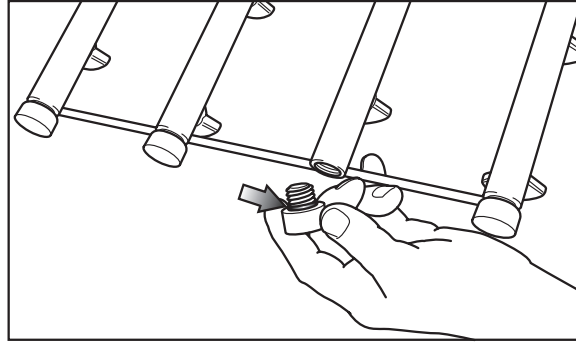
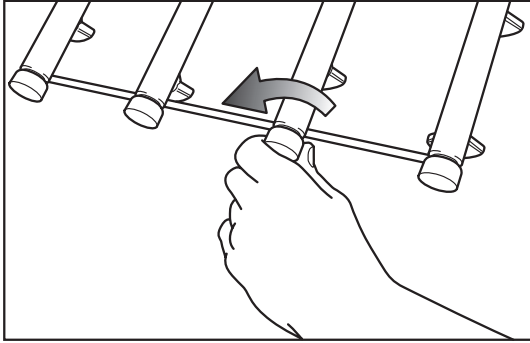

Installing the Lower Spray Arm Assembly

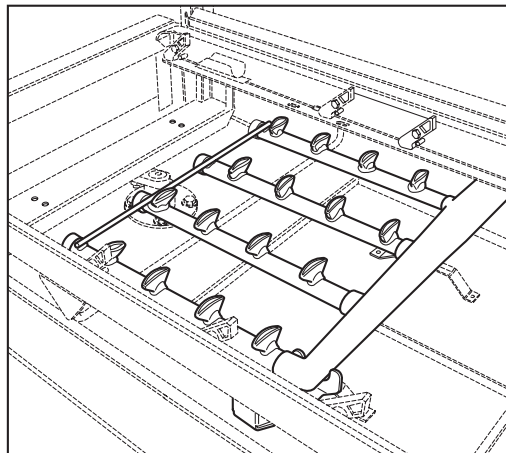
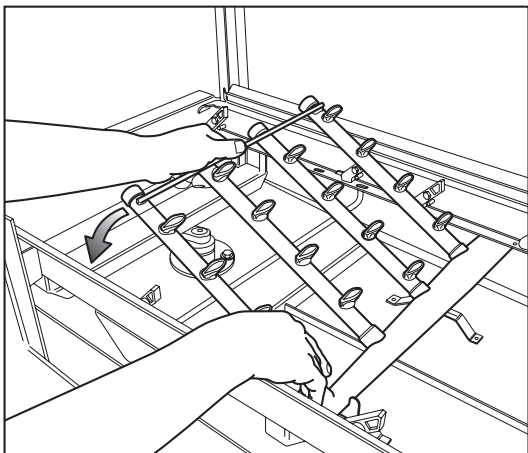
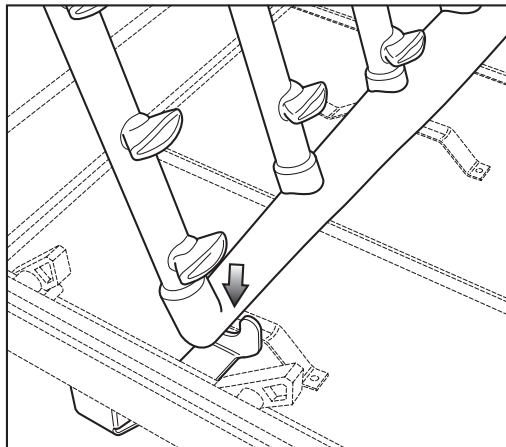
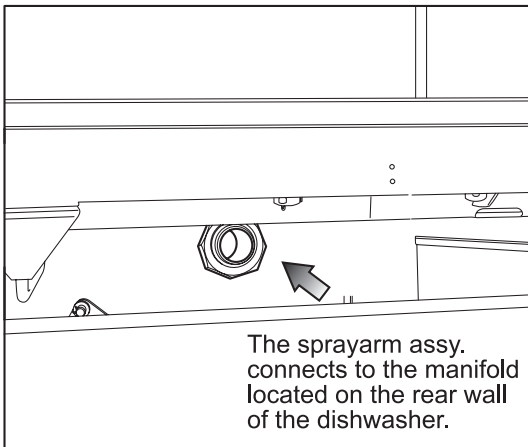

Installing the Upper Spray Arm Assembly

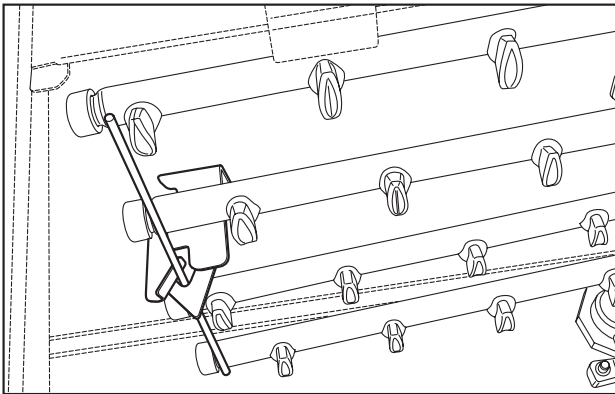
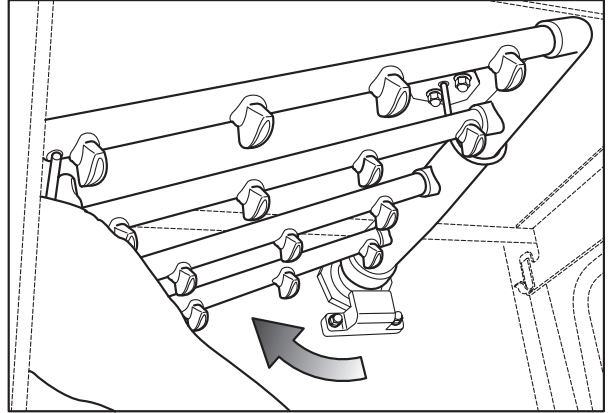
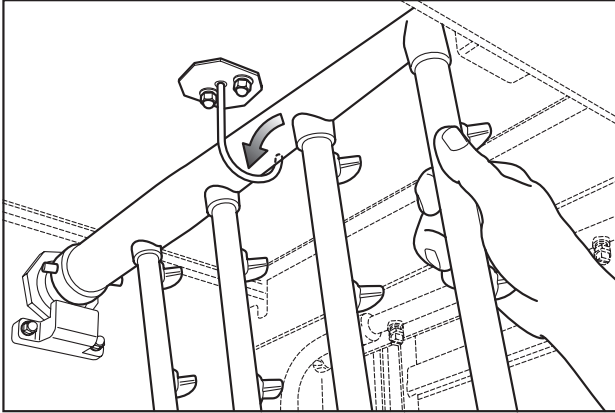

Removing the Spray Arm End Plugs

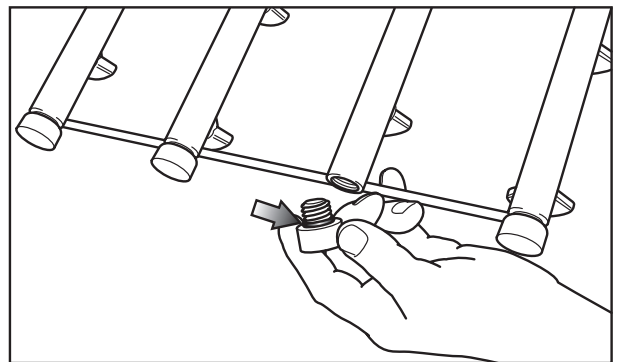
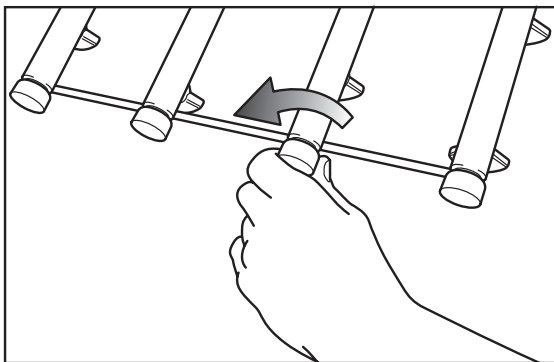

Installation

Removing the Dual Rinse (DR) scrap screens

Refer to the illustrations on this and the next page to remove and install the Dual Rinse (DR) scrap screens and rinse arm.

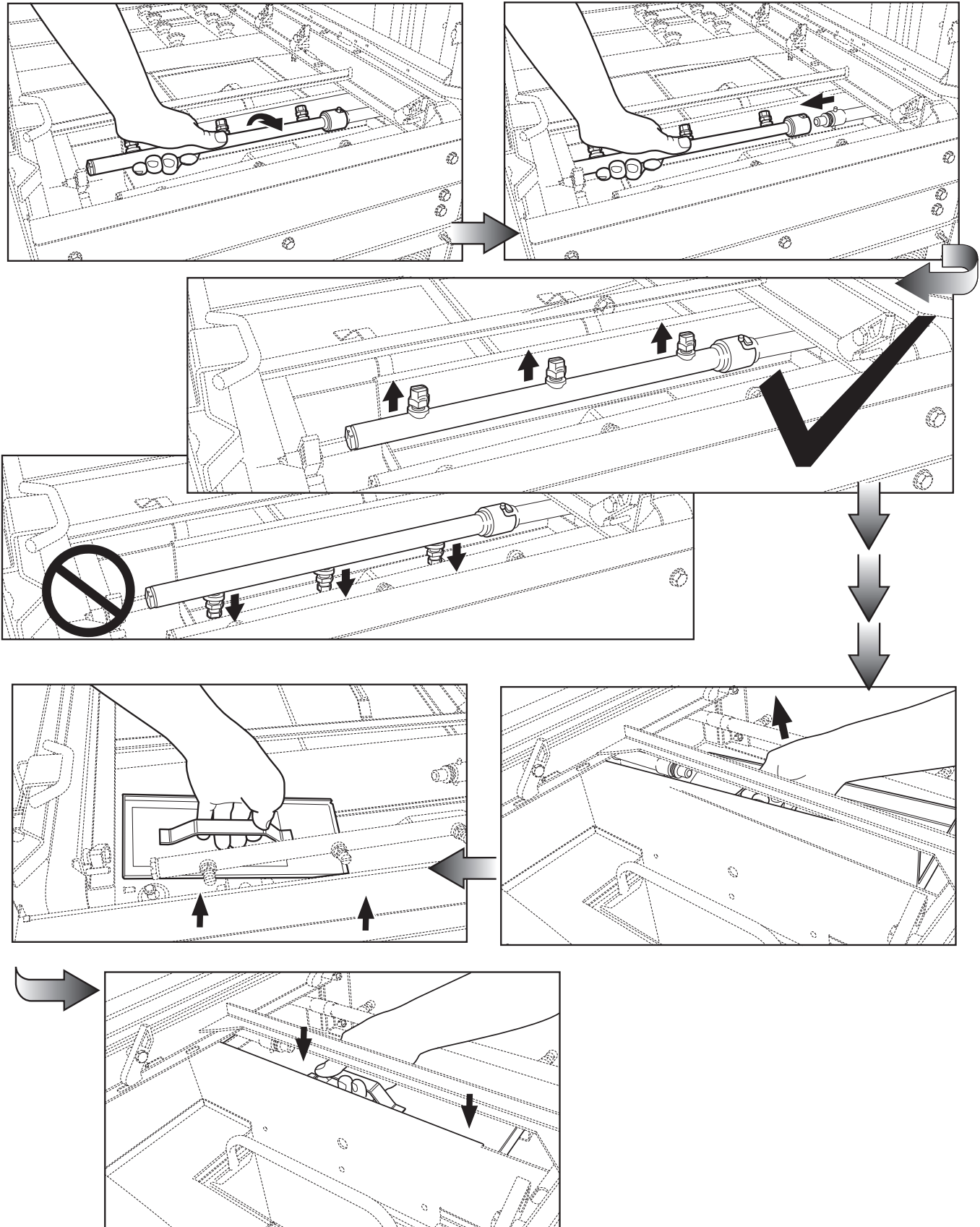

Installing the Dual Rinse (DR) scrap screens

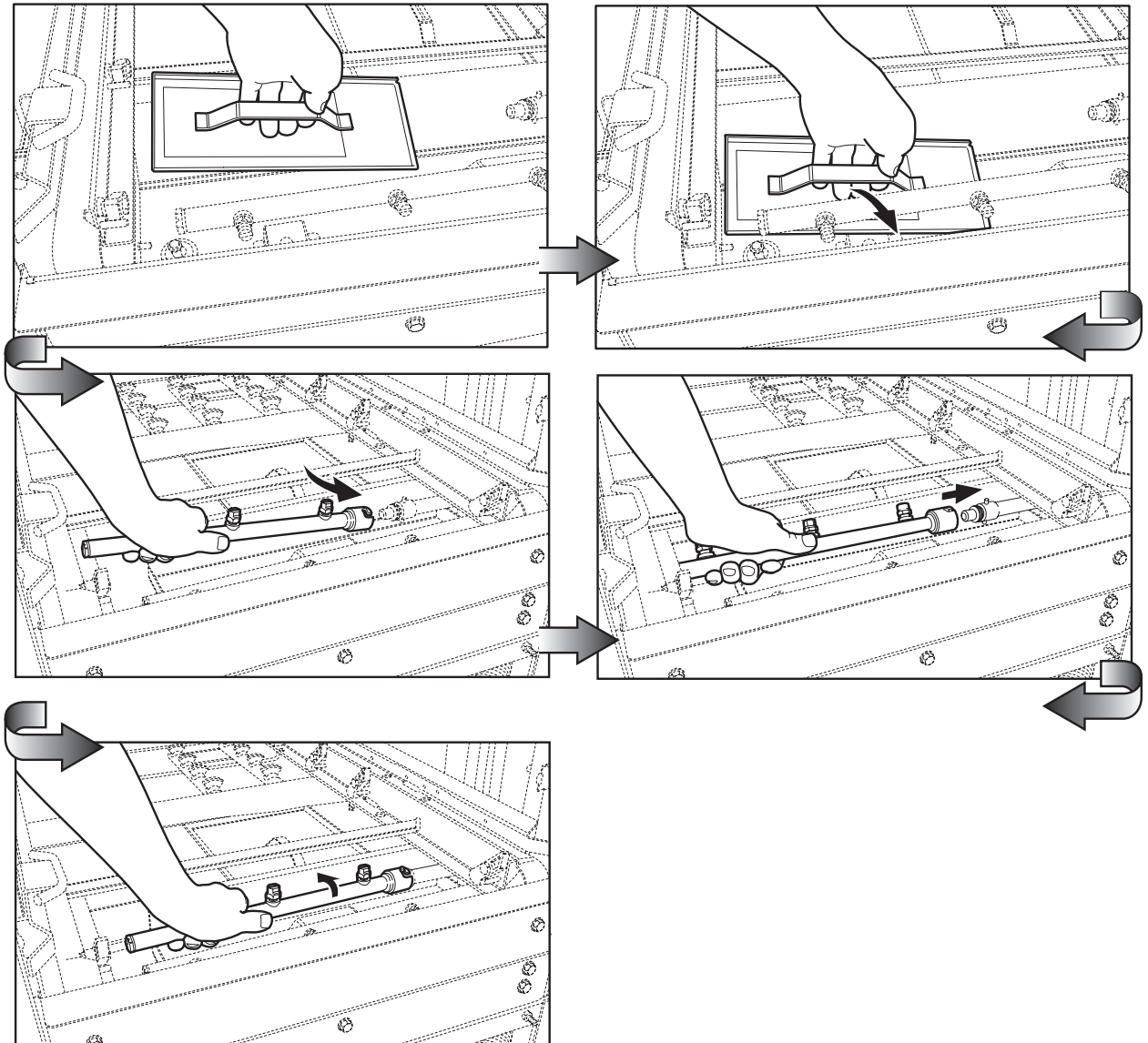

Installation

Check list

1. Remove white protective film from the dishwasher exterior.
2. Install lower panels to the dishwasher.
3. Remove any foreign material from inside of the machine.
4. Check that the chemical supplies (supplied by others) are full.
5. Check to ensure the dishwasher drains are closed.
6. Install scrap screens, baskets and spray arms.
7. Turn main utilities to the dishwasher ON. (Power, water, steam if applicable).
8. Make sure doors are closed.
9. Turn dishwasher power switch ON. The tanks fill with water and the tank and booster heat will come on.

NOTE:

The dishwasher will not start if the tanks are not full of water. If the dishwasher fills for more than 20 minutes, the dishwasher will shut down and the green indicator light will flash. Check the drain valves and make sure they are fully closed, then push the power switch OFF and back ON and push the Green Start button to resume operation.

10. Check the digital tank water temperature gauges to ensure they indicate the proper levels. The final rinse gauge displays OFF when the final rinse is not running.
11. Check for leaks.
12. Push the START button.
13. Insert an empty dish rack into the load end of the dishwasher.
The pumps and conveyor will run.
14. Carefully, open each dishwasher door to make sure the safety switch stops the conveyor and pumps.
15. Restart the dishwasher by pressing the START button.
16. Allow the dish rack to travel to the unload end of the dishwasher. The final rinse will run.
17. Allow the rack to exit the dishwasher. The dishwasher pumps and conveyor should stop when the rack exits the dishwasher.
18. Push the Stop button when the machine is running and the dishwasher should stop.
19. Push the START button, insert a dish rack into the load end of the machine and the pumps and conveyor should start.
20. Push the dishwasher Power Switch OFF. The dishwasher should shut down.
21. Drain the dishwasher and check that floor drains can handle the water volume leaving the dishwasher.

NOTE:

Opening a door will stop the pumps and drive. If the door is closed within 5 minutes the machine will resume operation where it left off. After 5 minutes the START switch must be pressed and a dish rack inserted into the machine for normal operation.

1. Check that the spray pipes, curtains, and scrap screens are in place and clean.
2. Check that the overflow drains are closed.
3. Check the chemical supplies (supplied by others). Turn on the detergent dispenser switches.
4. Turn on the exhaust vent system (if applicable), and make sure it is operating.
5. Close the door(s). Push the power switch ON..
Machine will begin to fill through the fill valve and the final rinse piping.
6. When the tanks are full, wait until the wash tank digital temperature gauge has reached the proper temperature. The digital tank temperature gauges are located on the control cabinet. Minimum wash temperatures are:
 - All single tank models - 160°F/71°C to 175°F/79°C
 - Single tank with Prewash - Wash Tank 160-175°F/71-79°C
 - The Prewash tank for all models has no temperature rating.
 - 2-tank (Wash Tank) 150-165°F TO 66°F/74°C
(Power Rinse Tank) 165-180°F TO 74°F/82°C
 - Final Rinse for all models is a minimum of 180-195°F/82-91°C.
 - Dual Rinse (if equipped) is 165-180°F/74-82°C rinse for all models.
7. Push the Green START button. The Green Cycle Light illuminates indicating the dishwasher is ready for automatic operation.
8. Pre-scrape wares to remove large food particles and load wares into the dish racks.
9. Pegged racks are for plates and/or trays. Flat racks are for bowls and/or silverware.
Spread silverware evenly in a single layer in a flat rack or upright (loosely packed) in a cutlery rack/cylinder.
10. Push a dish rack into the load-end of the dishwasher until it contacts the idle pump switch lever, the conveyor and pumps will start.
11. The dishwasher will run for 90 seconds to wash, rinse and move the dish rack out of the unload end of the dishwasher.
12. Inserting another dish rack into the machine before the first rack exits will keep the dishwasher running until the last dish rack exits the machine.
13. Check the final rinse pressure and temperature as the racks pass through the final rinse. This final rinse pressure MUST be 20-22 psi and the final rinse temperature MUST be a minimum of 180-195°F/82-91°C .
14. The pumps and the conveyor drive will automatically stop after the last rack exits the machine.
15. The machine may be stopped at any time during the cycle by pressing the red STOP pushbutton. The green light will go out.
16. Check the interior of the dishwasher for any dish racks still in the machine.
These dish racks must be washed again to ensure they are washed and sanitized completely.
17. To restart, push the green START pushbutton and push another dish rack into the dishwasher load end until the pumps and conveyor start.
18. Repeat steps 7-10 until all wares are washed.

Operation

Door Safety Switches

Dishwasher access doors are equipped with a door safety switch that automatically stops the dishwasher pumps and conveyor drive if a door is opened while the dishwasher is running. In addition, the dishwasher will not start if a door is left open.

1. If the dishwasher is running and a door is opened, the GREEN cycle light remains illuminated and the pumps and conveyor drive stop.
2. If the door is closed within 5 minutes the dishwasher will resume the cycle where it left off; after 5 minutes the green cycle light goes out and the START button must be pushed and a rack inserted into the machine.
3. Any dish racks left in the machine after 5 minutes have elapsed must be removed and processed again.
4. To restart the dishwasher, make sure all doors are closed, then push the GREEN START pushbutton and insert a rack into the load end of the machine. The green cycle light will illuminate; the pumps and conveyor motor will run.

Pump Intake Screen and Dual Float Switch

Refer to the illustration below and note the location of the pump intake screen and dual float switch.

1. Make sure the pump intake screen is installed by sliding it on the bracket located in front of the wash pump intake.
2. Make sure the float balls on the dual float switch move freely on the float stem.
3. Check the interior of the tank for any foreign objects and make sure the drain screen is clean.

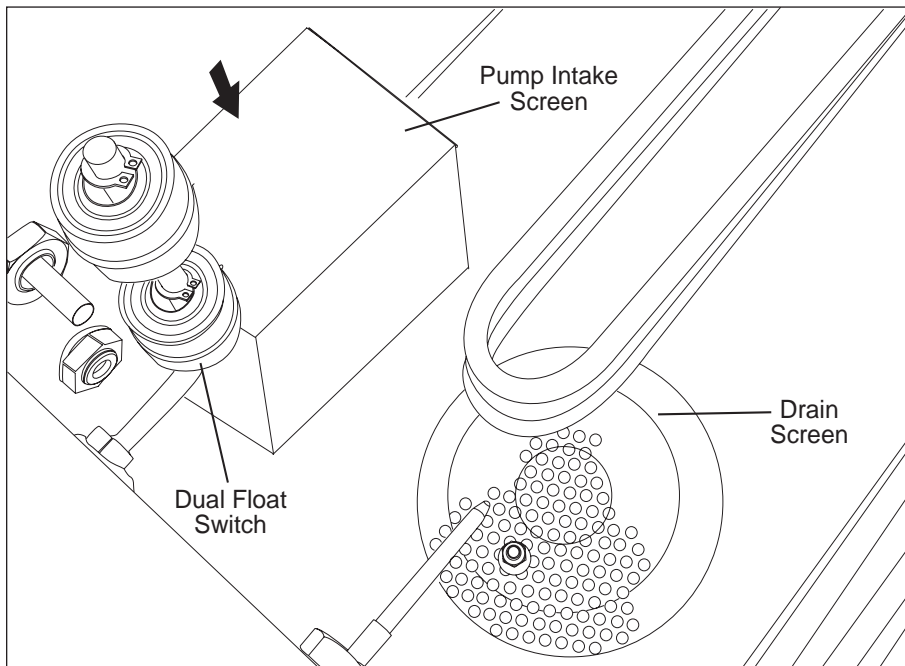

Make sure tank is clean, the pump intake screen is installed and the dual float switch moves freely.

***This Page
Intentionally
Left Blank***

Operation

Scrap Screens

1. All models have scrap screens in the tanks.
2. Install two scrap screens in each wash tank making sure they fit securely without large gaps between them.
3. Install an internal refuse basket in each wash tank.
4. If equipped, install one large scrap screen and one external refuse basket in the prewash tank.
5. For machines equipped with a dual rinse section, install two scrap screens in the dual rinse section.

! ATTENTION !

NEVER REMOVE A SCRAP SCREEN OR REFUSE BASKET WHEN THE DISHWASHER IS RUNNING.

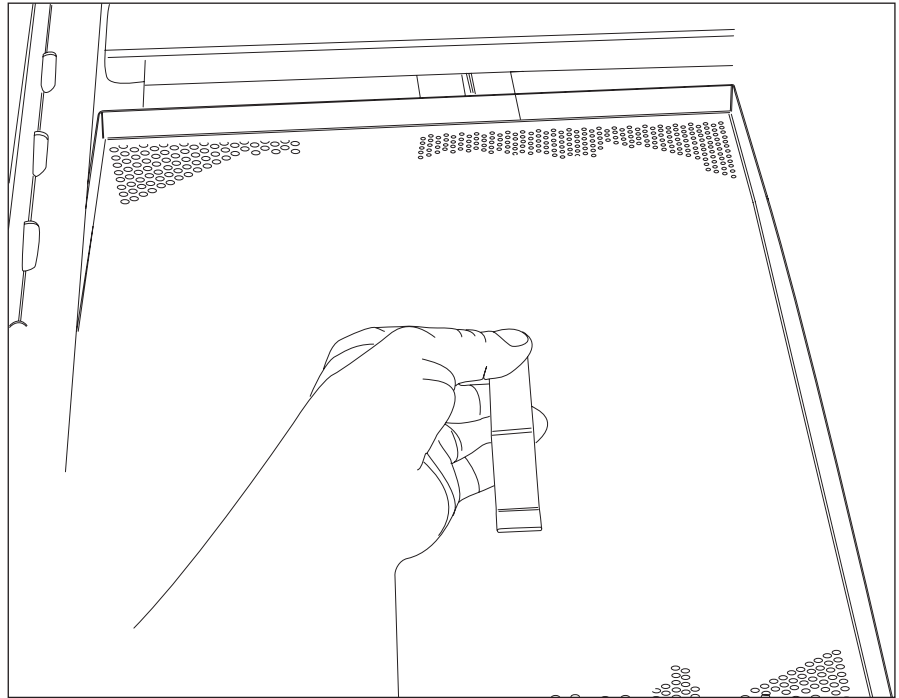

There are have scrap screens in the wash tank and one in the prewash tank

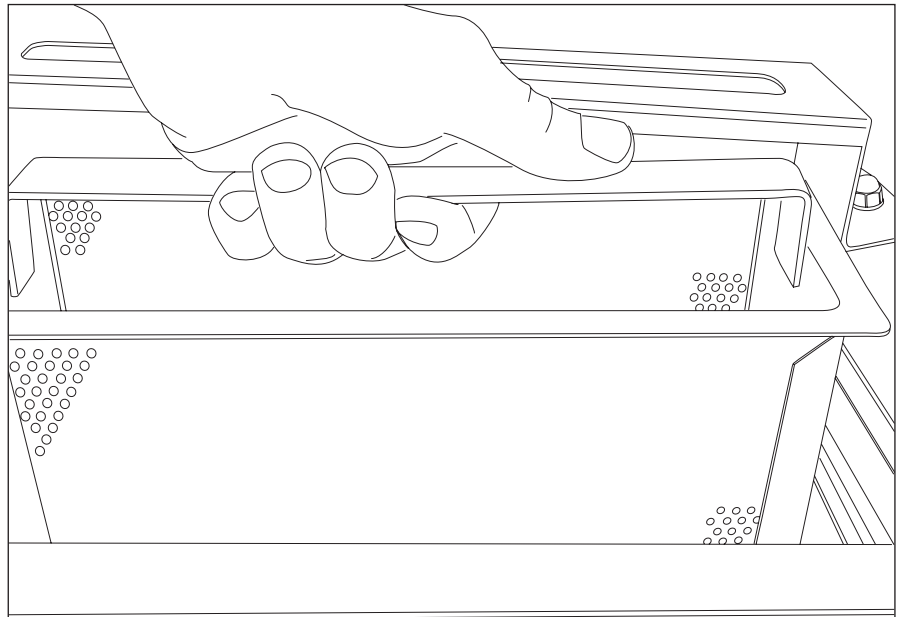

There is one refuse basket in the wash tank and an external basket in the prewash

Cleaning your dishwasher is the best maintenance you can perform. The cleaning intervals below are the minimum requirements for most dishwashers. You may need to clean your dishwasher more often when washing heavily soiled wares or during long hours of continuous operation.



Daily or every 2 hours of operation

1. Turn power switch to OFF.
2. Open drain lever(s) to drain water. Remove scrap screens and scrap baskets. Clean inside of the tanks and flush with clean water. Back flush the scrap screens until clean then reinstall in the machine.

DO NOT STRIKE SCREENS OR BASKETS AGAINST SOLID OBJECTS

3. Remove the spray arm assemblies. Remove the end cap from each spray arm.
4. Flush the spray arms and nozzles to remove any debris.
5. Replace the end caps. Check the condition of the manifold O-ring.
6. Reinstall the spray arms.
7. Remove and clean the curtains. Allow them to dry at the end of the day.
8. Leave the doors open between operations, allowing the machine to dry.
9. Make sure the final rinse nozzles are clear of mineral deposits.
10. Straighten a metal paper clip and use to clean the nozzles.
11. Check the temperature and pressure gauge readings during operation.
12. Inspect the machine for signs of water leaks.
13. Check the chemical supplies and refill as necessary.

Cleaning

Cleaning (continued)

At the End of the Day

1. Perform Steps 1-10 on the previous page.
2. Remove the upper and lower rinse and wash spray arms and end plugs and flush with fresh water.
3. Remove the Dual Rinse (DR) rinse arm assemblies and flush with fresh water.
4. Clean the final rinse arm nozzles using a small paper clip.
5. Remove the curtains and clean with fresh water.

DO NOT USE STEEL WOOL TO CLEAN THE INTERIOR OF THE MACHINE.

6. Wipe the interior and exterior of the machine with a soft cloth and a mild detergent.

DO NOT HOSE THE EXTERIOR OF THE MACHINE WITH WATER.

7. Reassemble the dishwasher and leave the door open to allow overnight drying
8. Contact the chemical supplier for de-liming if required.

De-liming

Lime (scale) deposits are the result of minerals contained in the water feeding the dishwasher and appear as a white haze on the surface of the dishwasher. Severe scaling can appear as a granular deposit. These deposits are a result of the mineral content in the geographic area of the machine's location.

WARNING:

Death or injury can result from toxic fumes when de-liming agents come in contact with Chlorine Bleach, or other chemicals that contain iodine, bromine, or fluorine.

USE EXTREME CAUTION WHEN HANDLING ANY DE-LIMING AGENT

CAUTION:

De-liming agents can cause chemical burns. Wear rubber gloves, eye protection and any other protective clothing as instructed by a qualified chemical supplier and follow the instructions provided by the chemical supplier.

! ATTENTION !

Place a flat-bottom dish rack upside down on the idle pump start switch at the entrance end of the dishwasher to keep the dishwasher running during the de-liming procedure.

Maintenance

Weekly

1. Inspect all water lines for leaks and tighten at joints if required.
2. Clean any detergent residue from the exterior of the machine.
3. Check the drain operation.
4. Clean any accumulated scale from the heating element.
5. Inspect the spray arms for any damage or missing parts.
6. Inspect the final rinse arms for missing parts.
7. Inspect the drive assembly and cradle for damaged or missing parts.
8. Check that float switches move freely.
9. Check the idle pump actuator and the final rinse actuator for freedom of travel.

Monthly

1. Inspect interior of machine for lime deposits and clean.
2. Check o-rings on spray arm piping connections.
3. Check the drain operation.
4. Clean any accumulated scale from the heating element.
5. Inspect the spray arms O-rings and ensure all plugs are installed.
6. Inspect the final rinse arms for missing parts and are clean.
7. Inspect the drive assembly and cradle for damaged or missing parts.
8. Check that float switches move freely.
9. Check the idle pump actuator and the final rinse actuator for freedom of travel.
10. Check the drive belt and adjust as necessary.
11. Check the pump rotation and direction of rotation.
12. Check the operation of temperature gauges or displays.
13. Perform complete operation check.

Yearly

1. Contact authorized service agent to perform complete maintenance review of machine.
2. Correct any abnormal situations as recommended.

E-Rack Digital Temperature Display Meters

! ATTENTION !

The Digital Temperature Displays only indicate temperature, they do not control wash tank or final rinse booster heaters. Electromechanical thermostats continue to control the tank and final rinse heat circuits.

1. The analog temperature gauges have been replaced with digital temperature display meters.
2. The meters display temperatures for the prewash tank (if equipped), the wash tank, power rinse tank (if equipped), the dual rinse (DR) tank (if equipped), and the final rinse.
3. A meter displays temperature in 2 ways:
 - a. The first display is a semi-circular LED bar that moves from left to right as the temperature increases in magnitude. The color of the bar changes from black, to orange, and to green.
 - b. The second display is a 3 digit LED that changes from OFF if the tank or final rinse heat is disabled, to Blank and from a minimum temperature of 70°F to the maximum calibrated temperature set point of the meter.

(Refer to the "Display Meter Operation Checks" on the next page to change a Meter set-point.)

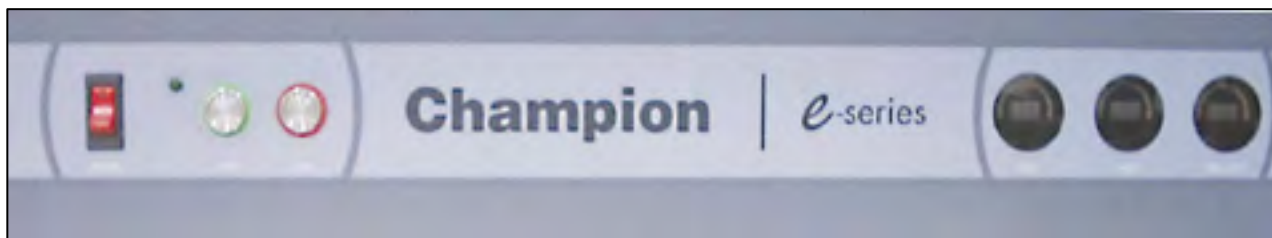

Control cabinet showing digital temperature display meters on the right-hand side of the control cabinet.



Close-up view of the display meters. Note the semi-circular indicator bars and the numeric readouts in the center.

Display Meter Operation Checks

Check the Meter LEDs:

1. Turn the Dishwasher Power Switch ON. The 3-digit LEDs illuminate simultaneously, the each LED bar illuminates from left-to-right.

Check the Meter Temperature Set-point:

Refer to the photo below and the "Rear view of the Digital Display Circuit Board" on the next page.

1. Remove the top-mounted control cabinet panel. Locate the CHECK pushbutton on the rear of the display. The pushbutton is located at the top and center of the board.
2. There are 6 set-point values: 70, 120, 150, 160, 165, and 180°F.
3. Turn the dishwasher Power Switch ON, then Push and Hold the CHECK pushbutton. Meter 1 flashes the current user-defined set-point. Meter 2 is blank.
4. Continue to Hold the CHECK pushbutton. Meter 1 blanks out and Meter 2 flashes its current set-point value of 70, 120, 150, 160, 165, and 180°F.
5. Release the CHECK button. Meter 1 and Meter 2 display the actual temperatures in the wash tanks.
6. A final rinse Meter will display OFF until the final rinse switch is activated, then the meter displays the actual final rinse temperature which is measured at the final rinse manifold.

Check the Meter Temperature Set-point:

The set-point determines how the meter displays the yellow and green bar. For example, if the set-point is 70, then the bar displays yellow from 0-70, then green from 70 and above.

1. Push and Hold the CHECK pushbutton until Meter 1 display flashes.
2. Release the CHECK pushbutton. Meter 1 goes through the set-point values each time the CHECK pushbutton is pushed and released. The set-point value advances from 70, 120, 150, 160, 165, and 180°F.

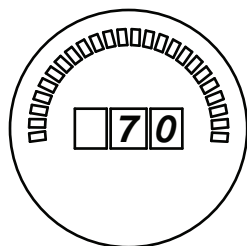

Set-point value of 70°F

3. When the new set-point appears on the display, hold the CHECK pushbutton until the display flashes. The number that is displayed is the new-set-point. If the display advances past the desired set-point, repeat Steps 1-2.
4. In order to change Meter 2, Push and Hold the CHECK pushbutton until Meter 1 flashes. Continue to Hold the CHECK pushbutton until Meter 2 flashes, and then repeat Steps 2-3 for Meter 2.

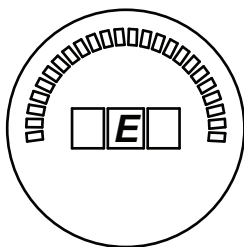
**Important:**

The letter "E" appears in the center of the 3-digit display when the thermistor is shorted or open.



Digital Display

Calibration

Calibration is an internal function of the display circuit board and does not calibrate temperature control of the dishwasher components.

NOTE:

The Thermistor Plug and 1 wire from the Rinse Switch Connector must be disconnected from the display circuit board before calibration.

To calibrate the display board:

1. Turn dishwasher Power Switch OFF.
2. Disconnect the thermistor plug and at least 1 wire from the rinse switch connector.
3. Turn Power Switch ON.
4. Press and Hold the CHECK pushbutton while pressing and releasing the RESET button.
5. Release the CHECK pushbutton.
6. Display shows "CAL" flashing on METER 1 and METER 2.

NOTE:

If the display shows "EEE", then the thermistor plug is not disconnected. Disconnect the thermistor plug and repeat Steps 1-6 above.



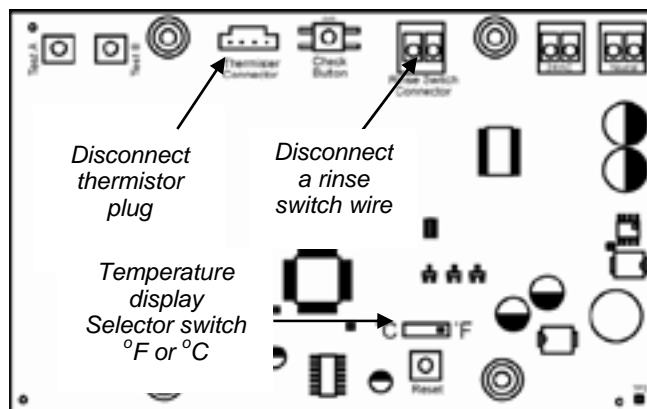
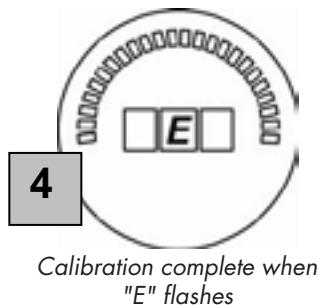
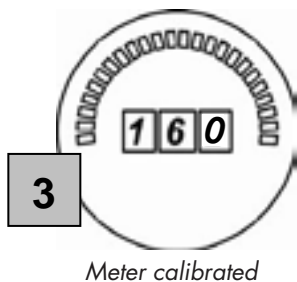
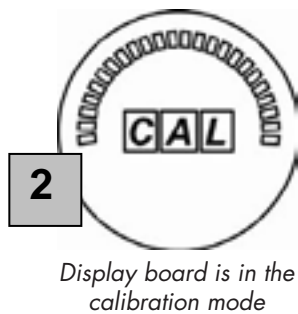
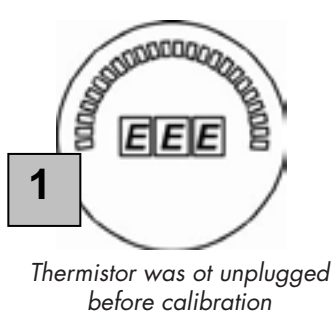







7. Press and Hold the TEST A pushbutton to calibrate Meter 1 (*Test B for Meter 2*).
8. The display calibrates and shows "160".
9. Release TEST A pushbutton. An "E" flashes in the center of METER 1.
10. Press the RESET pushbutton to exit the calibration mode.
11. Repeat Steps 2-8 to calibrate Meter 2.
12. Turn the dishwasher Power Switch OFF and reconnect the thermistor plug and rinse switch connector wire.
13. Turn Power Switch ON and return to normal operation.



Rear Detail View of Digital Display Circuit Board

Display Codes and Definitions

The illustrations below show the codes that may appear in the temperature meter displays.

START-UP		ERROR	
 <p>Number and bar LEDs cycle:</p> <ol style="list-style-type: none"> This is the Display segment test when the dishwasher power is turned ON. <i>Check for defective LED segments during the test.</i> 	 <p>E displayed and bar is blank.</p> <ol style="list-style-type: none"> Thermistor is open or shorted. <i>Troubleshoot the thermistor circuit connected to the display meter.</i> 		
OPERATION			
 <p>Numbers and bar are blank.</p> <ol style="list-style-type: none"> Main power or dishwasher OFF. Tank temp. below 70°F/21°C. <i>Turn power OFF then ON to check display segments (see below)</i> 	 <p>EXAMPLE</p> <p>ALL DISPLAY METERS: Numbers indicate between 70-209°F or 21-99°C; and the bar is illuminated left-to-right, from yellow to green.</p> <ol style="list-style-type: none"> Normal display meter operation Meter displaying temperature 		
 <p>FINAL RINSE METER ONLY OFF displayed - bar is blank.</p> <ol style="list-style-type: none"> Final rinse start switch is not operated and final rinse water is not flowing. 	 <p>HHH displayed and entire the bar is lit.</p> <ol style="list-style-type: none"> The temperature in the tank has exceeded 210°F/99°C. <i>Reset the hi-limit thermostat, then adjust or replace the temperature control thermostat.</i> 		
CALIBRATION			
<p>1</p>  <p>CAL displayed and bar is blank.</p> <ol style="list-style-type: none"> Display meter is in the calibration mode. <i>Press the RESET pushbutton on the display board to exit mode.</i> 	<p>2</p>  <p>EEE displayed and bar is blank.</p> <ol style="list-style-type: none"> Display meter is in the calibration mode. The thermistor was not unplugged prior to calibration. 		
<p>3</p>  <p>160 displayed and bar is blank.</p> <ol style="list-style-type: none"> Display meter is calibrated. <i>The meter should flash "E" in a few seconds.</i> 	<p>4</p>  <p>E flashes and bar is blank.</p> <ol style="list-style-type: none"> Calibration operation is complete for the display meter. <i>Press the RESET pushbutton on the display board to exit mode.</i> 		

Troubleshooting

Troubleshooting

Before calling for service, check the following conditions.

1. Dishwasher main power and water supply is on.
2. Machine has been assembled correctly.
3. Conveyor is clear of any obstructions.
4. Drains are closed.
5. Screens and pump intake screens are clear.
6. Doors are closed and secure.

Condition	Cause	Solution
Dishwasher will not run.	Door not closed. Main power OFF. Dishwasher OFF. Wash tanks not full	Close door completely. Check breaker on panel. Turn dishwasher ON. Check drain valves.
Low or no water.	Main water supply off. PRV setting incorrect or low incoming pressure. Solenoid strainer clogged. Solenoid valve defective. Defective float switch.	Open supply valve. Adjust the PRV to 22psi flowing pressure. Clean strainer. Contact Service Agent. Contact Service Agent.
Poor wash results.	Detergent not added to tank. Wares incorrectly loaded in dishrack. Clogged screens . Clogged spray arms. Thermostat defective. End plugs missing. Water temperature low.	Check detergent supply. Reposition wares or reduce amount of wares. Clean screens. Clean spray arms. Contact Service Agent. Check spray arms. Check incoming water temperature.
Dishwasher stays in wash cycle.	Idle pump switch defective. 90 second timer defective	Contact Service Agent. Contact Service Agent.
Dishwasher conveyor will not run.	Conveyor jammed or table limit switch has stopped conveyor. Green start button not pressed. Machine filled for 20 minutes but did not reach fill level and shut down.	Check conveyor for jams Remove racks from load end of table. Press Green start button & insert rack into machine. Check drain valves, turn power ON and OFF, then push Green Start button.
Low tank and/or final rinse temperature.	Incoming water temperature low. Defective heater. Defective temperature display.	Check incoming temperature/contact maintenance. Contact service agent. Contact service agent.

Service Replacement Parts

Illustration	Page
Front View of Control Panel	33
Control Cabinet Interior View for Single Tank Models with Dual Rinse.....	35
Control Cabinet Interior View for Two Tank Models	37
Prewash Panels and Curtains.....	44
Single Tank Panels and Curtains	46
Two Tank Panels and Curtains.....	48
Drive Motor Assembly.....	50
Conveyor Drive Assembly	52
Prewash Track and Cradle Assembly	54
Single Tank Track and Cradle Assembly.....	56
Two Tank Track and Cradle Assembly.....	58
Prewash Scrap Screens.....	60
Single Tank Scrap Screens.....	62
Two Tank Scrap Screens.....	64
Prewash Wash Spray Arms	66
Single Tank Wash Spray Arms	68
Two Tank Wash and Power Rinse Spray Arms.....	70
Dual Rinse (DR) Tank Assembly	72
Dual Rinse (DR) Pump/Motor Assembly.....	74
Prewash Pump Suction and Discharge	76
Wash and Power Rinse Pump Suction and Discharge	78
Pump/Motor Assembly	80
Float Switches.....	82
Single Tank Electric Wash Tank Heat	84
Two Tank Electric Wash and Rinse Tank Heat.....	86
Thermostats and Thermistors	88
Junction Box	90
Final Rinse Piping (All Models).....	92
Fill Piping (All Models)	94
Prewash Cold Water Tempering (CWT) Piping.....	96

(Continued on next page)

Service Replacement Parts (continued)

Illustration	Page
Single and Two Tank Electric Booster Assembly 40°F/70°F	98
Single Tank Booster Heaters 40°F/70°F	100
Two Tank Booster Booster Heaters 40°F/70°F	102
Two Tank and Heat Recovery Electric Booster Cabinet	104
Two Tank Steam Heat with K2 Steam Booster	106
Single Tank Steam Heat	108
Two Tank Steam Heat	110
22", 26" and 36" Prewash Drain Assemblies	112
E44DR with and without Prewash Drain Assembly	114
E54DR with and without Prewash Drain Assembly	116
E64 with and without Prewash Drain Assembly	118
E84 Drain Assembly	120
E84 with Prewash Drain Assembly	122
Final Rinse Drain Assembly	124
22" Prewash Door Assembly	126
E44 and E54 Door Assembly	128
E64, E84 and 36" Door Assemblies	130
Extended Vent Cowls and Splash Shields	132
Standard Vent Cowls	134
Single Tank Hot Water Coil (HWC) Heat	136
Two Tank Hot Water Coil (HWC) Heat	138
24" Sideloader	140
30" Sideloader	142
Dish Racks	144

Front View of Control Cabinet (All Models)

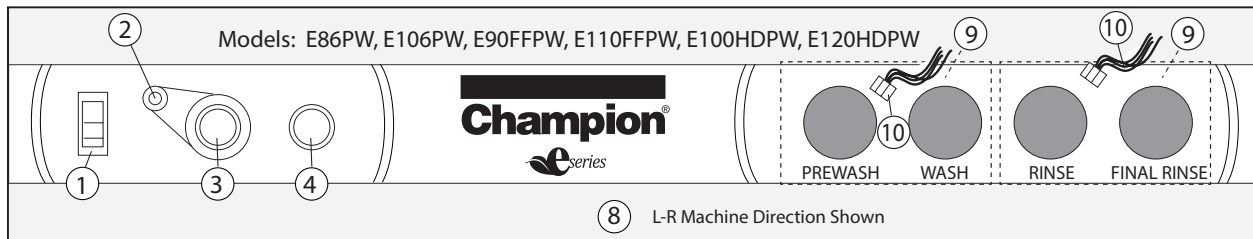
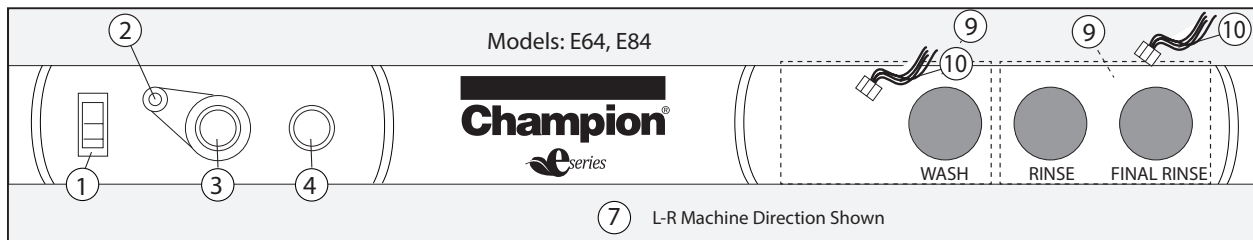
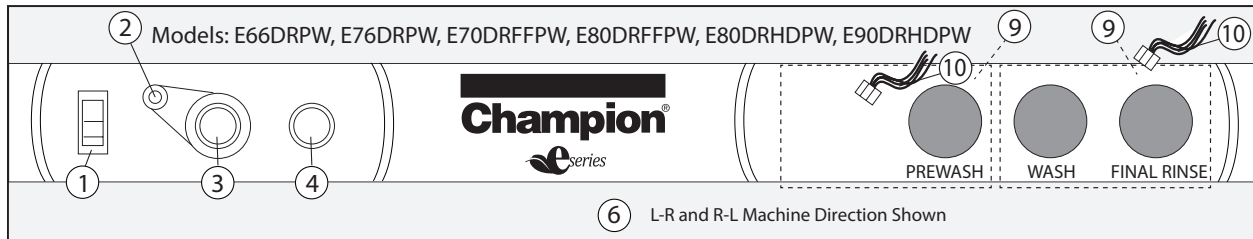
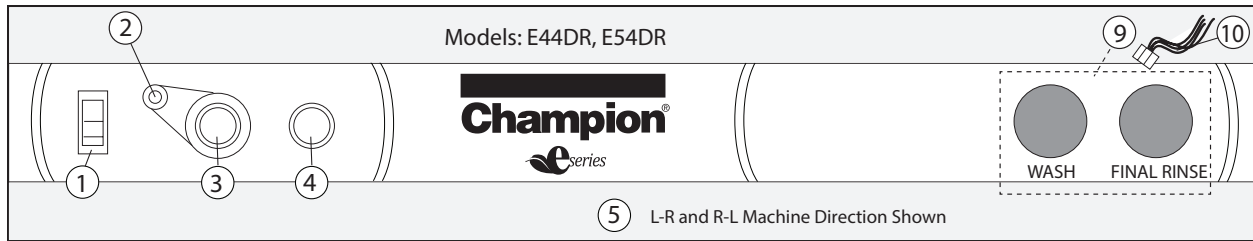

Item No.	Part No.	Description	Qty.
1	114505	Breaker, Switch 14A ON/OFF 24VAC,	1
2	116494	Light, Green LED 6VDC	1
3	115019	Pushbutton, Switch Green	1
4	115018	Pushbutton, Switch Red	1
5	114532	Decal (L-R, and R-L) (See illustration above for model nos.)	1
6	114533	Decal, (L-R and R-L) (See illustration above for model nos.)	1
7	114436	Decal, (L-R) (See illustration above for model nos.)	1
—	114534	Decal, (R-L) (See illustration above for model nos.)	1
8	114437	Decal, (L-R) (See illustration above for model nos.)	1
—	114438	Decal, (R-L) (See illustration above for model nos.)	1
9	114489	Gauge, Digital Temperature Display	A/R
—	114559	Support, Circuit Board (4 per board)	A/R
10	114508	Cable Assy., 4-conductor Thermistor (1 per display board)	1

Control Cabinet Interior View for Single Tank Models with Dual Rinse- Layout 1

Note: Control Cabinet Cover P/N 334879 not shown.

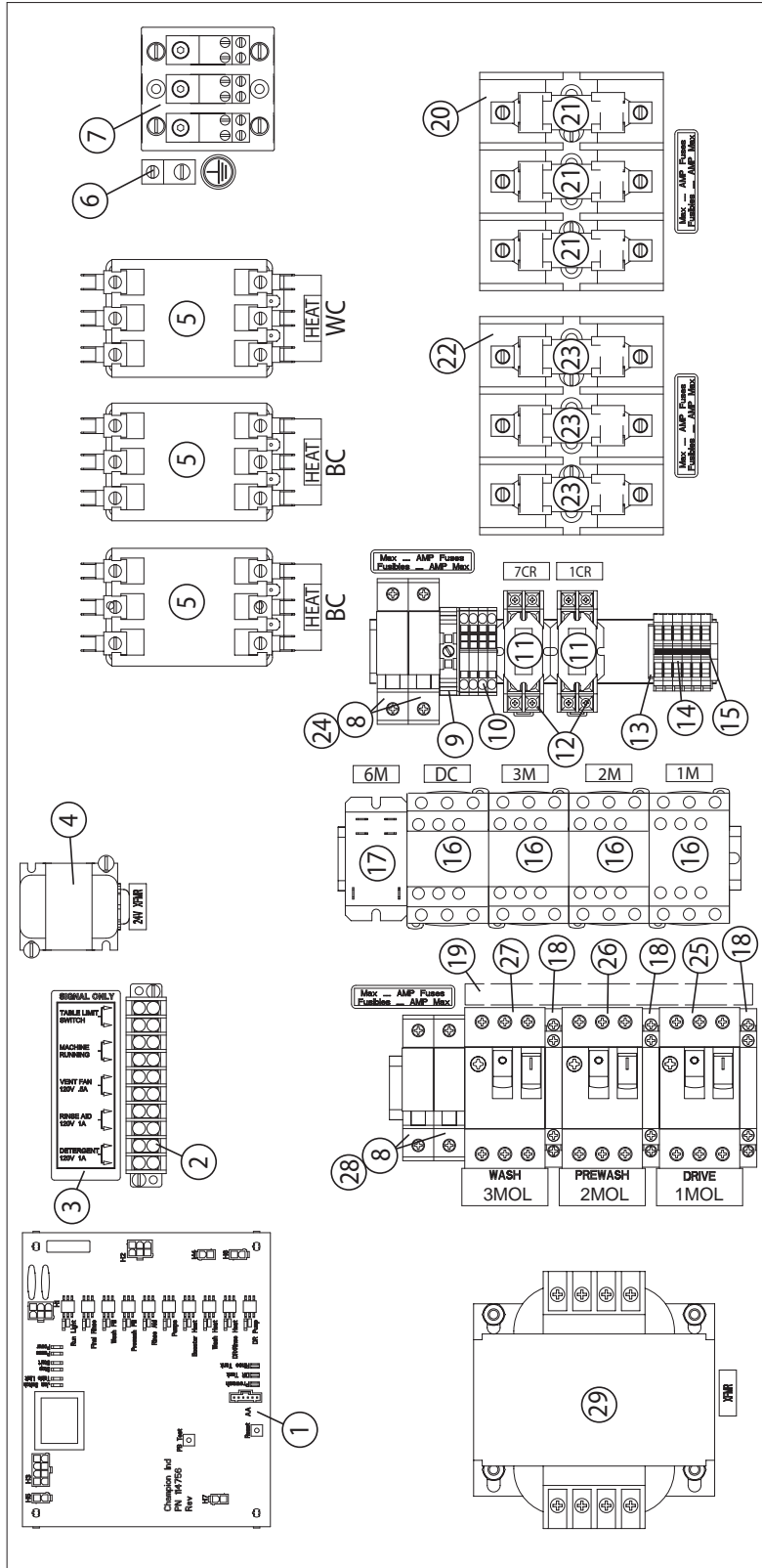

This illustration shows a control cabinet with all options. Your control cabinet may not have the prewash components nor the additional parts required for the 22KW booster. Please disregard these extra components as necessary.

Control Cabinet Interior View for Single Tank Models with Dual Rinse

Item No.	Part No.	Description	Qty.
<u>COMMON ELECTRICAL PARTS (Not Voltage Specific)</u>			
1	114756	Circuit Board, Control	1
—	114759	Support, Circuit Board	4
2	115147	Block, Terminal 10-Pole	1
—	115345	Jumper, Slotted	1
3	115158	Label (TLS, Machine Run, etc.)	1
4	114898	Transformer, 120:24VAC 20VA	1
5	111827	Contactor, Heat 60 FLA	A/R
6	103310	Lug, Ground Wire	1
7	111833	Block, Input Terminal 175A, 3-Pole	1
8	111153	Block, Fuse 600V 30A	2
9	114519	End Block, E/NS 35 N	1
10	114512	Terminal, Single ST 2.5 Gray	4
11	111068	Relay, 2PDT, 10A 120VAC	2
12	111036	Socket, Relay	2
13	114521	End Cover, Single Terminal D-MZB 1.5 NS35	1
14	114520	Terminal, Single MZB 1.5 NS35	6
15	114522	Bridge, Terminal 10-Pole FBS 10-5 (Cut to fit)	1
16	108122	Contactor, 12A	A/R
17	115161	Relay, DPDT 30A 120VAC (DR Pump)	1
18	112367	Contact, Auxiliary GVAN11	A/R
19	111633	Bus-System, 2-units (Drive and Wash)	1
—	111671	Bus-System, 3-units (Drive, Prewash, Wash)	1
<u>VOLTAGE SPECIFIC PARTS:</u>			
<u>200-220V/60/3 (Wash Tank Heat)</u>			
20	180171	Block, Fuse 600V 60A 3P J Type	1
21	180175	Fuse, J 50A 600V	3
<u>200-220V/60/3 (12KW Booster)</u>			
22	180171	Block, Fuse 600V 60A 3P J Type	1
23	180174	Fuse, J 45A 600V	3
<u>200-220V/60/3 (22KW Booster)</u>			
22	108424	Block, Fuse 600V 100A 3P T Type	1
23	180059	Fuse, T 80A 250V	3

(Continued on next page)

Control Cabinet Interior View for Single Tank Models with Dual Rinse

Item No.	Part No.	Description	Qty.
<u>VOLTAGE SPECIFIC PARTS:</u>			
<u>200-220V/60/3</u>			
24	111822	Fuse, Line 120VAC, 5A 600V LPCC-5	2
25	111624	Overload, Motor (Drive) 0.63-1.0A	1
26	111628	Overload, Motor (Prewash) 4.0-6.3A	1
27	111629	Overload, Motor (Wash) 6.0-10.0A	1
28	100922	Fuse, DR Heat 600V 20A, ATMR-20	2
29	107091	Transformer, 500VA	1
<u>230-240V/60/3 (Wash Tank Heat)</u>			
20	180171	Block, Fuse 600V 60A 3P J Type	1
21	180174	Fuse, J 45A 600V	3
<u>230-240V/60/3 (12KW Booster)</u>			
22	180171	Block, Fuse 600V 60A 3P J Type	1
23	180173	Fuse, J 40A 600V	3
<u>230-240V/60/3 (22KW Booster)</u>			
22	108424	Block, Fuse 600V 100A 3P T Type	1
23	180060	Fuse, T 70A 250V	3
<u>230-240V/60/3</u>			
24	111822	Fuse, Line 120VAC, 5A 600V LPCC-5	2
25	111624	Overload, Motor (Drive) 0.63-1.0A	1
26	111628	Overload, Motor (Prewash) 4.0-6.3A	1
27	111629	Overload, Motor (Wash) 6.0-10.0A	1
28	100922	Fuse, DR Heat 600V 20A, ATMR-20	2
29	107091	Transformer, 500VA	1
<u>460-480V/60/3 (Wash Tank Heat)</u>			
20	111135	Block, Fuse 600V 30A 3P J Type	1
21	180243	Fuse, J 25A 600V	3
<u>460-480V/60/3 (12KW Booster)</u>			
22	111135	Block, Fuse 600V 30A 3P J Type	1
23	112062	Fuse, J 20A 600V	3
<u>460-480V/60/3 (22KW Booster)</u>			
22	180171	Block, Fuse 600V 60A 3P J Type	1
23	180172	Fuse, J 35A 250V	3

(Continued on next page)

Control Cabinet Interior View for Single Tank Models with Dual Rinse

Item No.	Part No.	Description	Qty.
<u>VOLTAGE SPECIFIC PARTS:</u>			
<u>460-480V/60/3</u>			
24	111821	Fuse, Line 120VAC, 5A 600V LPCC-3	2
25	111624	Overload, Motor (Drive) 0.63-1.0A	1
26	111626	Overload, Motor (Prewash) 1.6-2.4A	1
27	111627	Overload, Motor (Wash) 2.5-4.0A	1
28	100913	Fuse, DR Heat 600V 10A, ATMR-10	2
29	107091	Transformer, 500VA	1
<u>575V/60/3 (Wash Tank Heat)</u>			
20	111135	Block, Fuse 600V 30A 3P J Type	1
21	112062	Fuse, J 20A 600V	3
<u>575V/60/3 (12KW Booster)</u>			
22	111135	Block, Fuse 600V 30A 3P J Type	1
23	111682	Fuse, J 15A 600V	3
<u>575V/60/3 (22KW Booster)</u>			
22	111135	Block, Fuse 600V 30A 3P J Type	1
23	111683	Fuse, J 30A 600V	3
<u>575V/60/3</u>			
24	107289	Fuse, Line 120VAC, 2.5A 600V LPCC-2-1/2	2
25	111624	Overload, Motor (Drive) 0.63-1.0A	1
26	111626	Overload, Motor (Prewash) 1.6-2.4A	1
27	111627	Overload, Motor (Wash) 2.5-4.0A	1
28	100913	Fuse, DR Heat 600V 10A, ATMR-10	2
29	111046	Transformer, 500VA	1

NOTE: Hot water coil (HWC) machines do not have heat contactors. These parts are replaced by the parts listed below and the parts are mounted in the control cabinet where the heat contactors were installed.

Hot Water Coil Heat Dishwashers Components (Not Shown)

—	111068	Relay, 2PDT, 10A 120VAC	1
—	111036	Socket, Relay	1
—	102346	Terminal, 2-Pole	1

Control Cabinet Interior View for Two Tank Models

Note: Control Cabinet Cover P/N 334879 not shown.

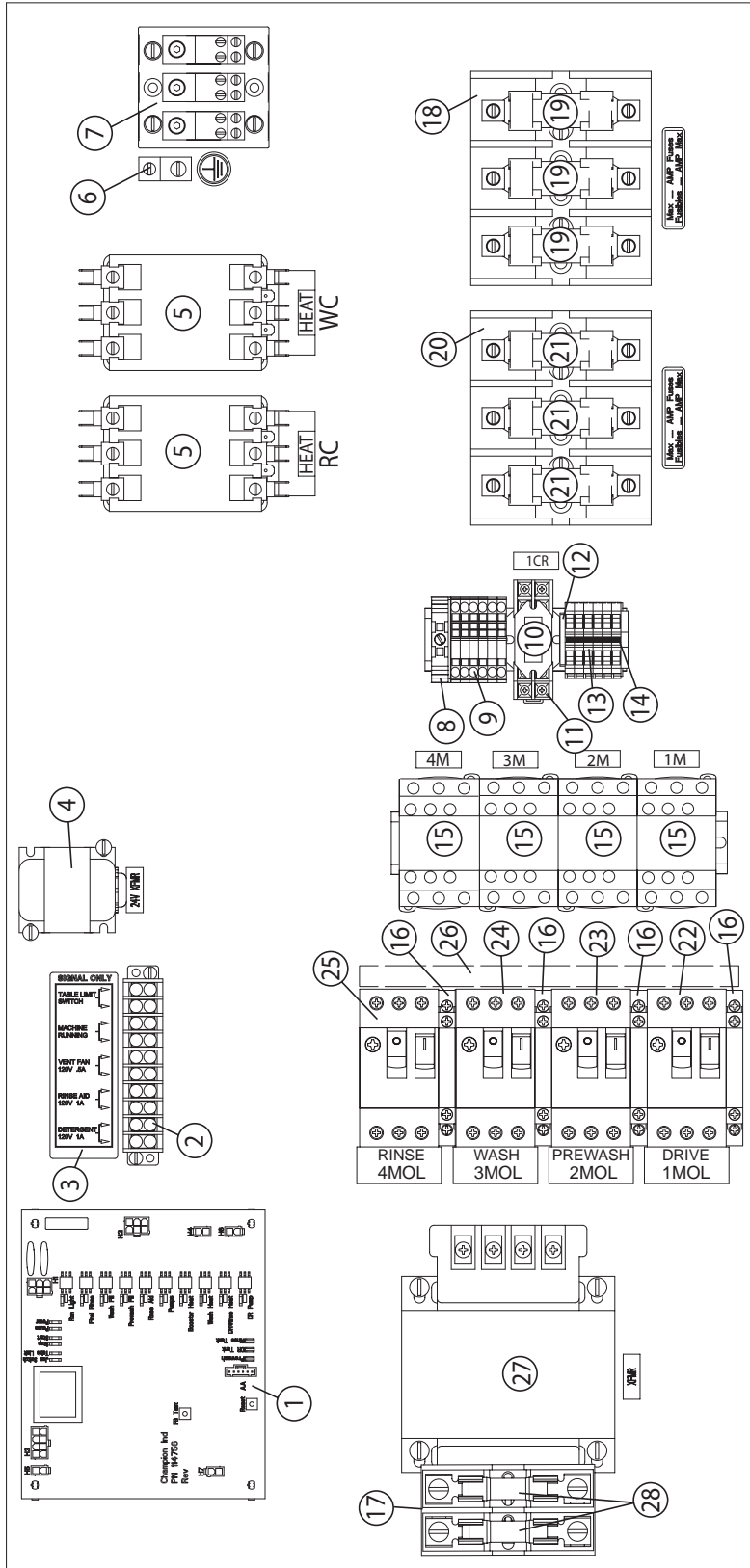

This illustration shows a control cabinet with all options. Your control cabinet may not have the prewash components nor the additional parts required for the 22KW booster. Please disregard these extra components as necessary.

Control Cabinet Interior View for Two Tank Models

Item No.	Part No.	Description	Qty.
<u>COMMON ELECTRICAL PARTS (Not Voltage Specific)</u>			
1	114756	Circuit Board, Control	1
–	114759	Support, Circuit Board	4
2	115147	Block, Terminal 10-Pole	1
–	115345	Jumper, Slotted	1
3	115158	Label (TLS, Machine Run, etc.)	1
4	114898	Transformer, 120:24VAC 20VA	1
5	111827	Contactor, Heat 60 FLA	2
6	103310	Lug, Ground Wire	1
7	111833	Block, Input Terminal 175A, 3-Pole	1
8	114519	End Block, E/NS 35 N	1
9	114512	Terminal, Single ST 2.5 Gray	6
10	111068	Relay, 2PDT, 10A 120VAC	2
11	111036	Socket, Relay	2
12	114521	End Cover, Single Terminal D-MZB 1.5 NS35	1
13	114520	Terminal, Single MZB 1.5 NS35	6
14	114522	Bridge, Terminal 10-Pole FBS 10-5 (Cut to fit)	1
15	108122	Contactor, 12A	A/R
16	110811	Contact, Auxiliary GVAN11	A/R
17	112424	Kit, Fuse Block	1
26	111671	Bus-System, 3-units (Drive, Prewash, Wash)	1
–	111634	Bus-System, 4-units (Drive, Prewash, Wash, Rinse)	1
<u>VOLTAGE SPECIFIC PARTS:</u>			
<u>200-220V/60/3 (Wash Tank Heat)</u>			
18	180171	Block, Fuse 600V 60A 3P J Type	1
19	180175	Fuse, J 50A 600V	3
<u>200-220V/60/3 (Rinse Tank Heat)</u>			
20	180171	Block, Fuse 600V 60A 3P J Type	1
21	180172	Fuse, J 35A 600V	3

(Continued on next page)

Control Cabinet Interior View for Two Tank Models

Item No.	Part No.	Description	Qty.
<u>VOLTAGE SPECIFIC PARTS:</u>			
<u>200-220V/60/3</u>			
22	111624	Overload, Motor (Drive) 0.63-1.0A	1
23	111628	Overload, Motor (Prewash) 4.0-6.3A	1
24	111629	Overload, Motor (Wash) 6.0-10.0A	1
25	111629	Overload, Motor (Rinse)	1
27	109064	Transformer, 250VA	1
28	112482	Fuse, 600V LPCC-3.5A	2
<u>230-240V/60/3 (Wash Tank Heat)</u>			
18	180171	Block, Fuse 600V 60A 3P J Type	1
19	180174	Fuse, J 45A 600V	
<u>230-240V/60/3 (Rinse Tank Heat)</u>			
20	180171	Block, Fuse 600V 60A 3P J Type	1
21	111683	Fuse, J 30A 600V	3
<u>230-240V/60/3</u>			
22	111624	Overload, Motor (Drive) 0.63-1.0A	1
23	111628	Overload, Motor (Prewash) 4.0-6.3A	1
24	111629	Overload, Motor (Wash) 6.0-10.0A	1
25	111629	Overload, Motor (Rinse) 6.0-10.0A	1
27	109064	Transformer, 250VA	1
28	112482	Fuse, 600V LPCC-3.5A	2
<u>460-480V/60/3 (Wash Tank Heat)</u>			
18	111135	Block, Fuse 600V 30A 3P J Type	1
19	180243	Fuse, J 25A 600V	3
<u>460-480V/60/3 (Rinse Tank Heat)</u>			
20	111135	Block, Fuse 600V 30A 3P J Type	1
21	112062	Fuse, J 20A 600V	3

(Continued on next page)

Control Cabinet Interior View for Two Tank Models

Item No.	Part No.	Description	Qty.
<u>VOLTAGE SPECIFIC PARTS:</u>			
<u>460-480V/60/3</u>			
22	111623	Overload, Motor (Drive) 0.4-.063A	1
23	111626	Overload, Motor (Prewash) 1.6-2.4A	1
24	111627	Overload, Motor (Wash) 2.5-4.0A	1
25	111627	Overload, Motor (Rinse) 2.5-4.0A	1
27	109064	Transformer, 250VA	1
28	112484	Fuse, 600V LPCC-1.5A	2
<u>575V/60/3 (Wash Tank Heat)</u>			
20	111135	Block, Fuse 600V 30A 3P J Type	1
21	112062	Fuse, J 20A 600V	3
<u>575V/60/3 (Rinse Tank Heat)</u>			
22	111135	Block, Fuse 600V 30A 3P J Type	1
23	111682	Fuse, J 15A 600V	3
<u>575V/60/3</u>			
22	111624	Overload, Motor (Drive) 0.63-1.0A	1
23	111626	Overload, Motor (Prewash) 1.6-2.4A	1
24	111627	Overload, Motor (Wash) 2.5-4.0A	1
25	111627	Overload, Motor (Rinse) 2.5-4.0A	1
27	109064	Transformer, 250VA	1
28	112484	Fuse, 600V LPCC-1.5A	2

NOTE: Hot water coil (HWC) machines do not have heat contactors. These parts are replaced by the parts listed below and the parts are mounted in the control cabinet where the heat contactors were installed.

Hot Water Coil Heat Dishwashers Components (Not Shown)

—	111068	Relay, 2PDT, 10A 120VAC	1
—	111036	Socket, Relay	1
—	102346	Terminal, 2-Pole	1

Solid State Control Board Cable Assemblies

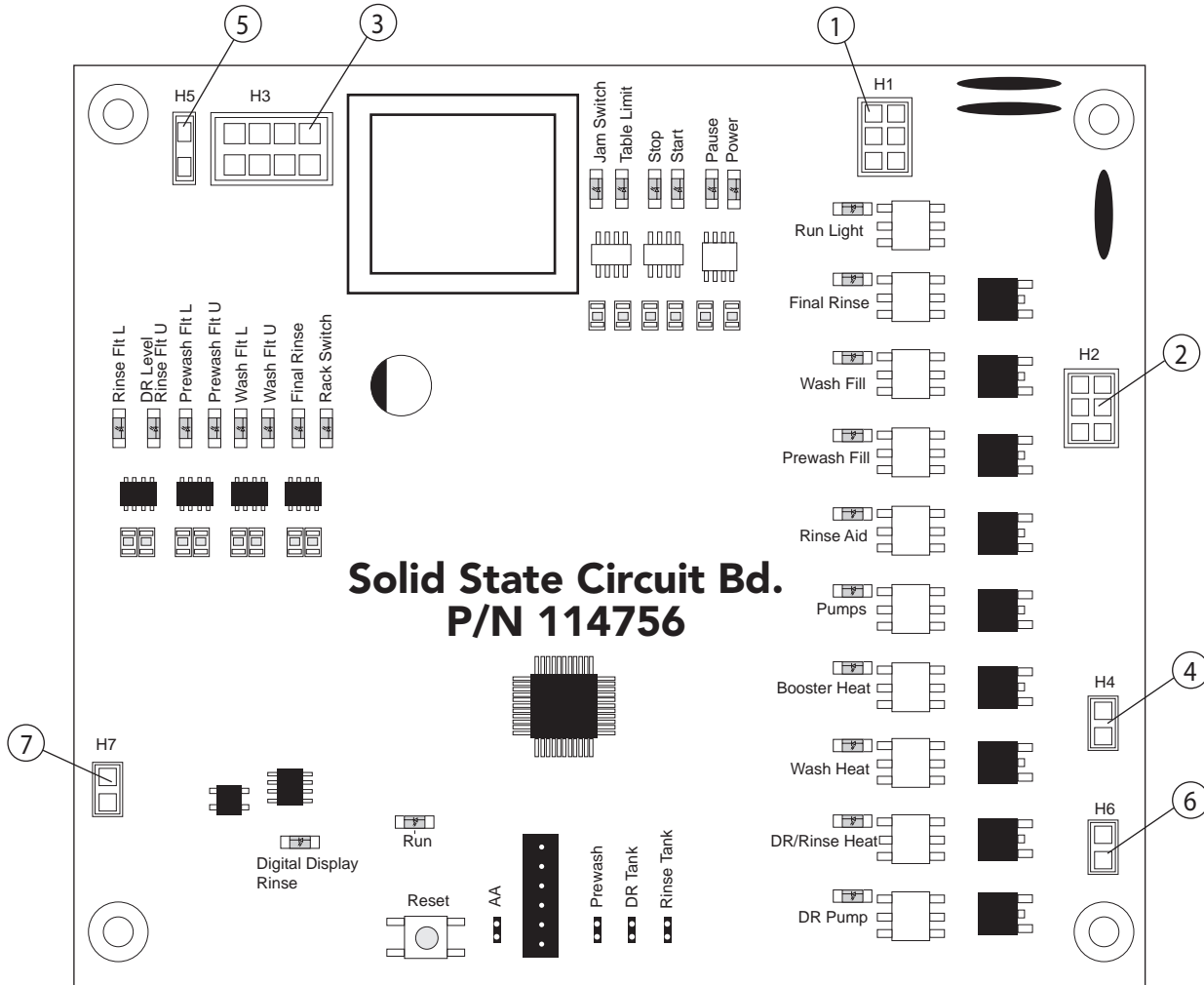

Item No.	Part No.	Description	Qty.
1	115173	Harness, 6-pin Input E44/54 DR,DRPW, E64/84 E64/84PW	1
2	115174	Harness, 6-pin Output E44/54 DR,DRPW, E64/84 E64/84PW	1
3	115175	Harness, 8-pin Input E64/84 E64/84PW	1
-	115180	Harness, 8-pin Input E44/54 DR,DRPW	1
4	115176	Harness, 2-pin Output E64/84 E64/84PW	1
-	115181	Harness, 2-pin Input E44/54 DR,DRPW	1
5	115177	Harness, 2-pin Input E64/84 E64/84PW	1
-	115182	Harness, 2-pin Input E44/54 DR,DRPW	1
6	115178	Harness, 2-pin Output E64/84 E64/84PW	1
-	115182	Harness, 2-pin Output E44/54 DR,DRPW	1
7	115179	Harness, 2-pin Output All Models	1

Control Cabinet Interior View for Single Tank Models with Dual Rinse - Layout 2

Note: Control Cabinet Cover P/N 334879 not shown.

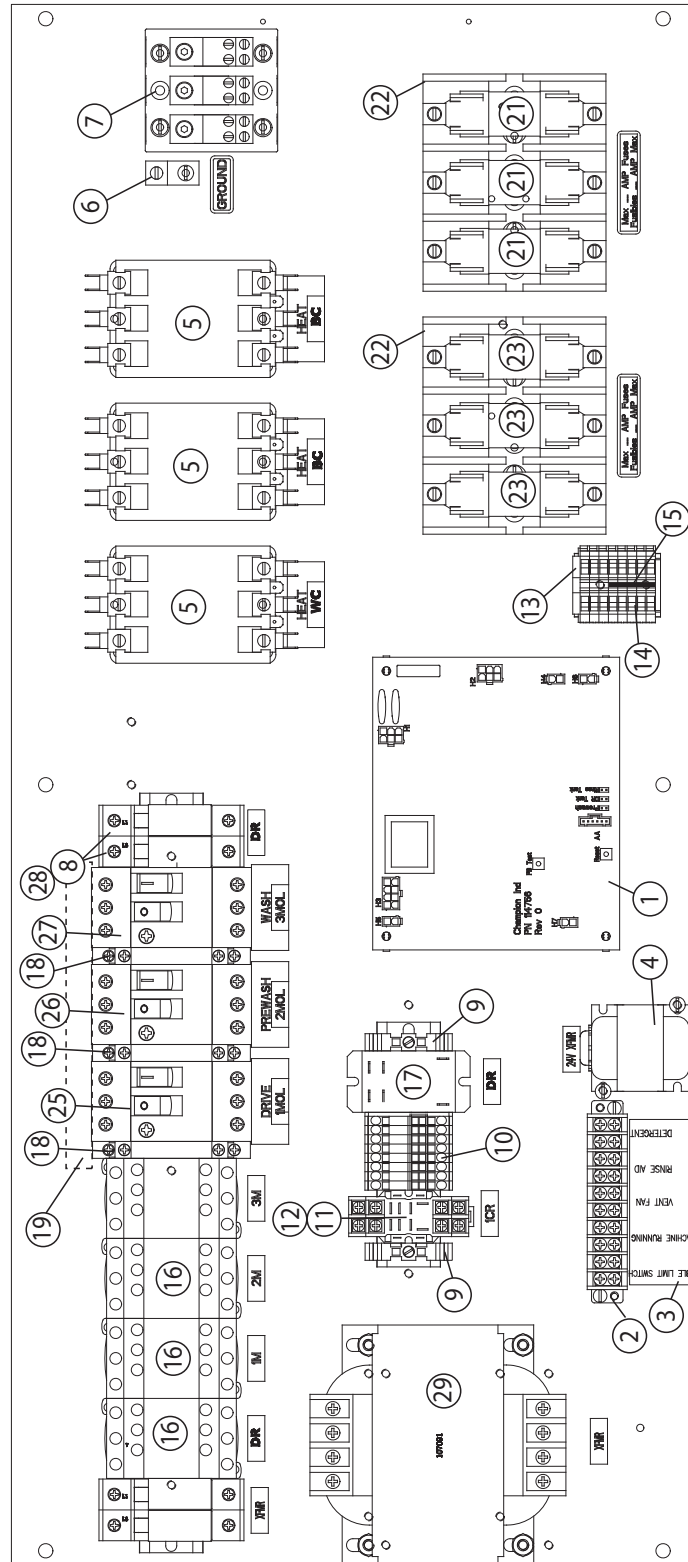

This illustration shows a control cabinet with all options. Your control cabinet may not have the prewash components nor the additional parts required for the 22KW booster. Please disregard these extra components as necessary.

See pages 35-37 for P/N's

Prewash Panels and Curtains

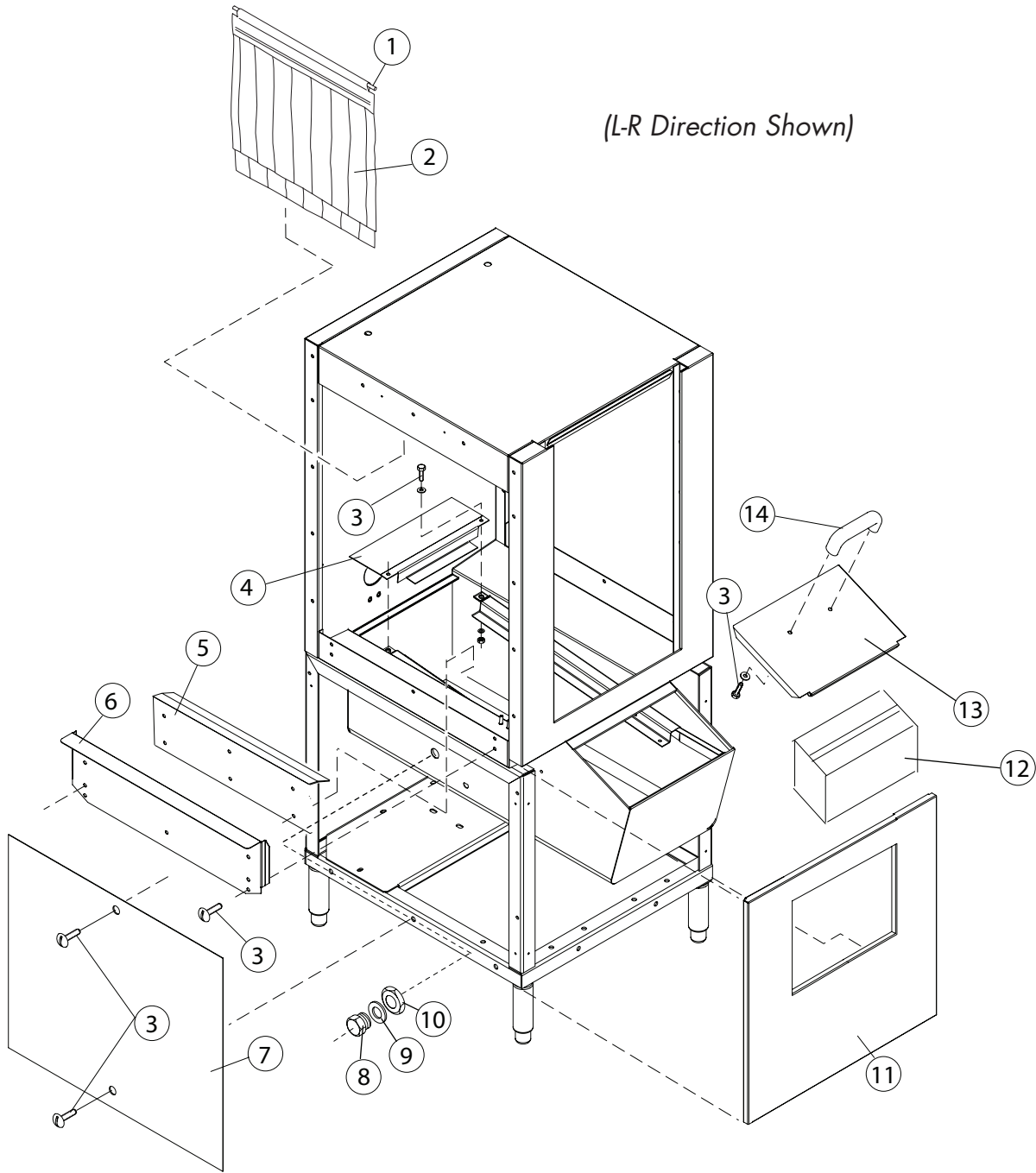

Item No.	Part No.	Description	Qty.
1	113828	Rod Curtain 5/16 x 21-1/2"	2
2	113720	Curtain 24 x 20-1/4"	2
3	100073	Screw 1/4-20 x 1/2 Truss Head	8
4	328006	Support, 22" PW Rear Screen	1
5	329926	Baffle, Table Flange	1
6	328030	Table Flange Support	1
7	329351	Panel, 25" End Standard	1
8	108418	Plug, 1/2"	2
9	109034	Gasket	2
10	108417	Nut	2
11	335223	Panel Assy. Front Perimeter 22" PW Prewash	1
-	334756	Panel Assy. Front Perimeter 26" PW Prewash	1
-	335224	Panel Assy. Front Perimeter 36" PW Prewash	1
12	328959	Basket, Refuse 22"	1
-	329492	Basket, Refuse 26"	1
-	328967	Basket, Refuse 36"	1
13	328427	Cover, Refuse Basket 22"	1
-	328524	Cover, Refuse Basket 36"	1
14	108966	Handle, Door	1

Single Tank Panels and Curtains

(L-R Direction Shown)

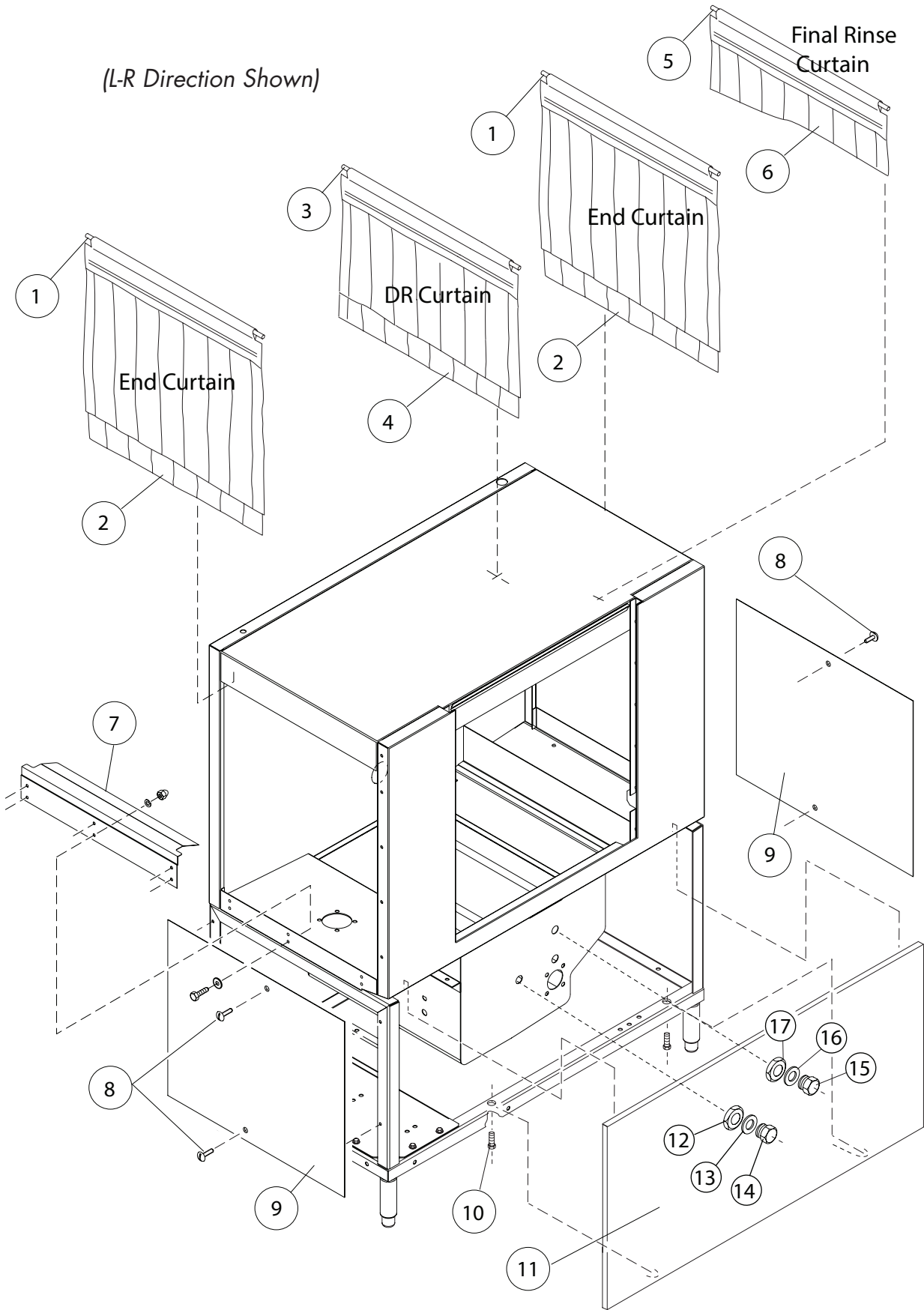

Item No.	Part No.	Description	Qty.
1	113828	Rod, Curtain, 5/16 x 21-1/2"	2
2	113720	Curtain 24" x 20-1/4" (End Curtain)	2
3	114012	Rod, Curtain, 5/16" x 23-1/2"	1
4	108043	Curtain, 24" x 13-1/4" (DR Curtain)	1
5	108250	Rod, Curtain 5/16" x 24-5/8"	2
6	109723	Curtain 24" x 6 -1/4" (Rinse Curtain)	1
7	329926	Baffle	1
8	100007	Screw 10-32 x 3/8" Truss Head	4
9	329351	Panel, 25" End Standard	2
10	100734	Bolt 1/4-20 x 1/2 SST	2
11	335219	Panel Assy., 44 Front Perimeter	1
-	335220	Panel Assy., 54 Front Perimeter	1
12	113944	Nut, 3/4" NPT	2
13	108620	Gasket	2
14	113943	Plug, 3/4" NPT	2
15	108418	Plug, 1/2" NPT	4
16	109034	Gasket	4
17	108417	Nut, 1/2" NPT	4

Two Tank Panels and Curtains

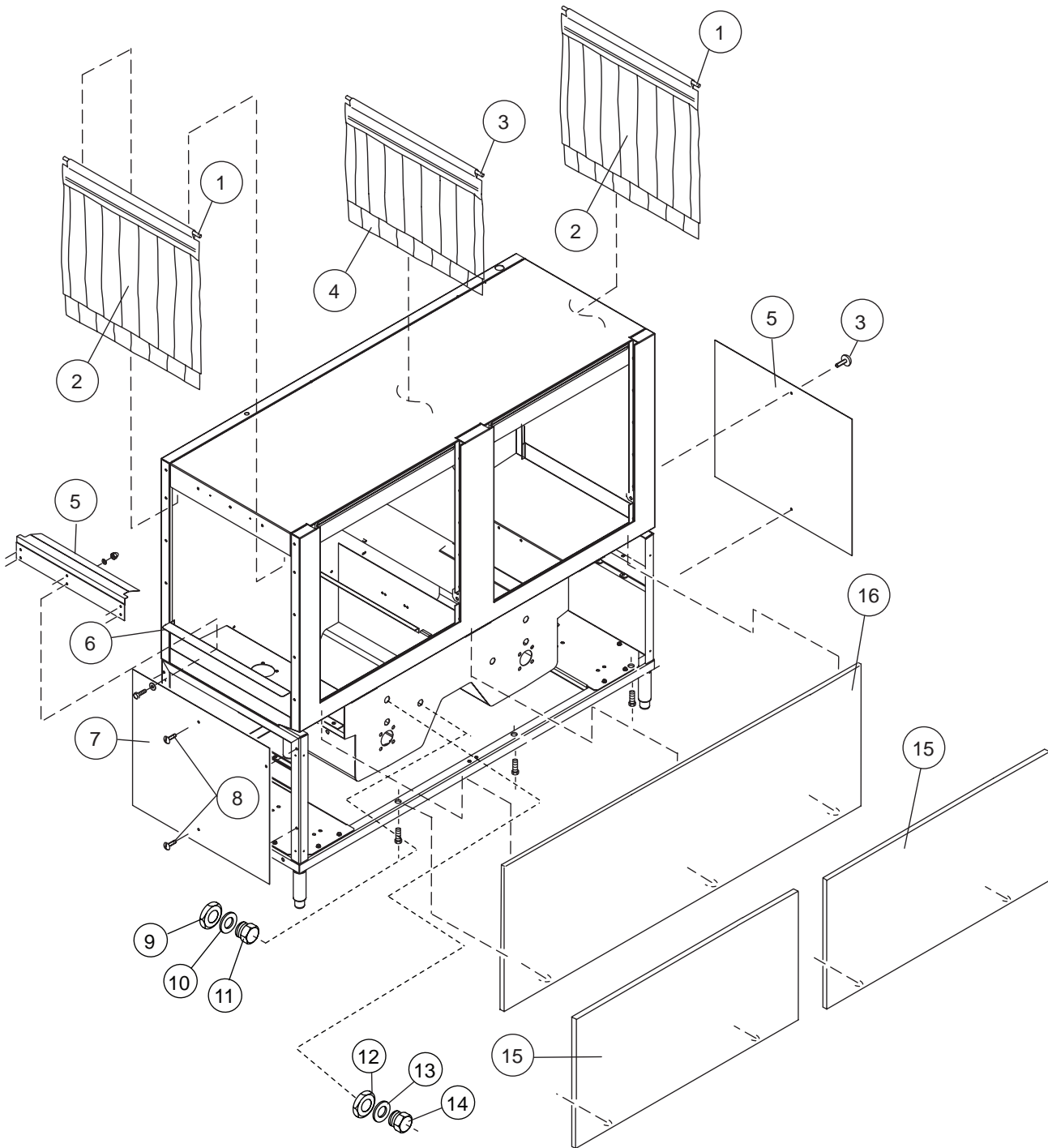

Two Tank Panels and Curtains

Item No.	Part No.	Description	Qty.
1	113828	Rod, Curtain, 5/16 x 21-1/2"	2
2	113720	Curtain 24 x 20-1/4"	2
3	114012	Rod, Curtain, 5/16" x 23-1/2"	1
4	108043	Curtain, 24" x 13-1/4"	1
5	329926	Baffle	1
6	328030	Table Flange	2
7	329351	Panel, 25" End standard	1
8	100073	Screw 1/4-20 x 1/2 Truss Head	8
9	113944	Nut, 3/4" NPT	4
10	108620	Gasket	4
11	113943	Plug, 3/4" NPT	4
12	108417	Nut, 1/2" NPT	4
13	109034	Gasket	4
14	108418	Plug, 1/2" NPT	4
15	328976-01	Panel, 84 Front Perimeter RH/LH	2
16	335221	Panel, 64 Front Perimeter	1

Drive Motor Assembly

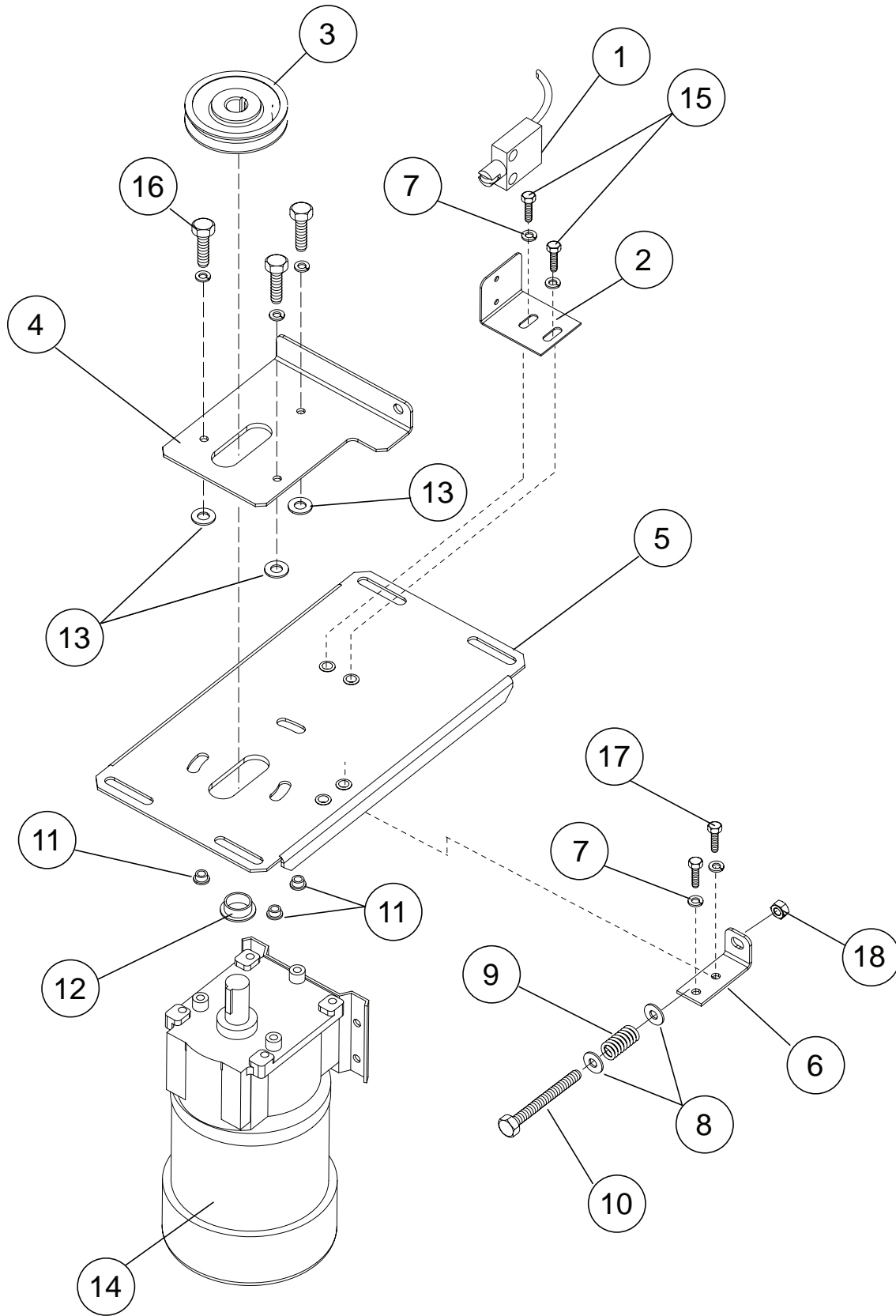

Item No.	Part No.	Description	Qty.
1	0509199	Drive Motor Switch	1
2	327918	Bracket, Motor Switch Mounting	1
3	<u>See Sheave and V-Belt Chart Below</u>		—
4	327916	Plate, Drive Motor Mounting	1
5	327920	Plate, 44 Motor Assy Mounting	1
5	327917	Plate, 64 Motor Assy Mounting	1
6	327919	Bracket, Motor Spring Mounting	1
7	106482	Washer Lock 1/4 Split SST	4
8	102376	Washer, Flat 5/16 x 3/4 x .06 SST	2
9	113702	Spring 0.6OD x 0.095 Wire x 1.5 Lg	1
10	113704	Screw, 5/16 x 3-1/2 Hex Head SST	1
11	113700	Bushing 3/8 x 3/4 x 1/16 Thrust Bronze	3
12	113703	Bushing, 3/4 x 7/8 x 3/8 x 1-1/8 Flg	1
13	113701	Bushing 1/4 x 3/8 x 1/2 x 1/16 Flg Bronze	1
14	113732	Motor, Gear 1/6HP 3PH, MV	1
15	100734	Bolt 1/4-20 x 1/2 Hex Head SST	2
16	100736	Bolt 1/4-20 x 3/4 Hex Head	3
17	100734	Bolt 1/4-20 x 1/2 Hex Head SST	2
18	109009	Grip Nut, 5/16-18 w/nylon insert	1

Sheave and V-belt Chart

Model	Motor Sheave Part No.	Drive Sheave Part No.	V-Belt Drive Part No.
E44DR	103166: AK39 5/8 Bore	113892: AK59 5/8 Bore	100794: 4L 310
E54DR	113896: AK54 5/8 Bore	113892: AK59 5/8 Bore	100797: 4L 340
E64	113689: AK46 5/8 Bore	113896: AK54 5/8 Bore	100797: 4L 340
E84	103170: AK49 5/8 Bore	108897: AK44 5/8 Bore	100794: 4L 310

Conveyor Drive Assembly

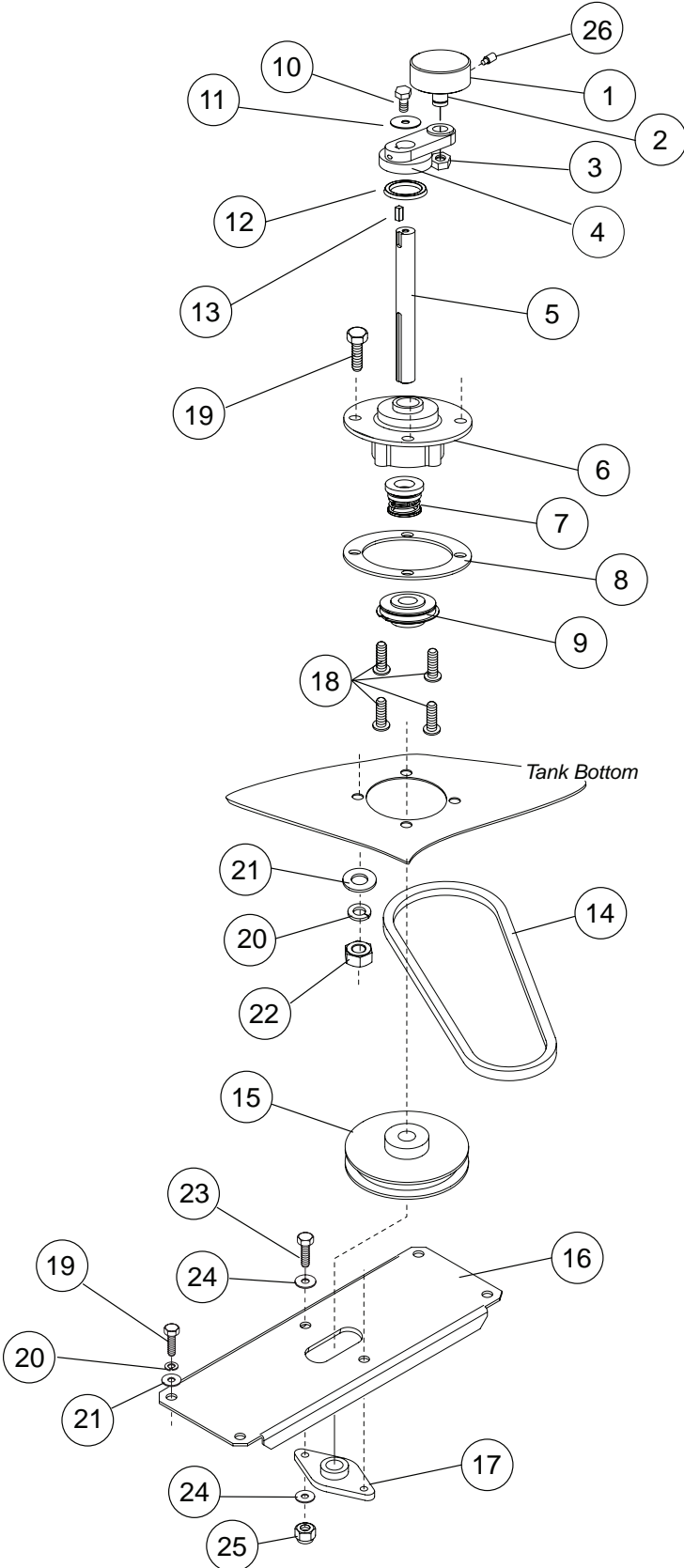

Item No.	Part No.	Description	Qty.
1	202381	Roller Crosshead	1
2	100868	Roller Stud Crosshead	1
3	107089	Nut Jam 1/2-13	1
4	206300	Crank, Rack Arm	1
5	206301	Shaft 5/8" O.D. x 9" LG.	1
6	113861	Housing, Bearing/Seal	1
7	102244	Seal 5/8"	1
8	206303	Gasket/Bearing Seal	1
9	100382	Bearing Jaf #EK104-10	1
10	100007	Screw, 10-32 x 3/8 Truss Head	1
11	104925	Washer 1/4 x 1 x 16 Gauge	1
12	103180	Wiper Ring	1
13	104916	Key 3/16 x 3/16 x 3/4 SST	1
14	<u>See Sheave and V-belt Chart on previous page.</u>		—
15	<u>See Sheave and V-belt Chart on previous page.</u>		—
16	327924	Bracket, 44 Drive Bearing Mounting	1
17	113860	Bearing, Sealed 5/8 Bore	1
18	104923	Screw 1/4-20 x 3/8 Round Head	4
19	100739	Bolt 5/16-18 x 3/4 Hex Head SST	8
20	106013	Washer Lock 5/16 Split	8
21	102376	Washer, flat 5/16"	8
22	100154	Nut Plain 5/16-18 SST	8
23	100746	Bolt 3/8-16 x 1-1/4" Hex Head	2
24	104618	Washer 3/8 x 7/8 x 1/16 SST	2
25	109010	Grip Nut, 3/8" w/nylon insert	2
26	100769	Screw, Set 3/8-16" x 3/4" Dog Point	1

Prewash Track & Cradle Assembly

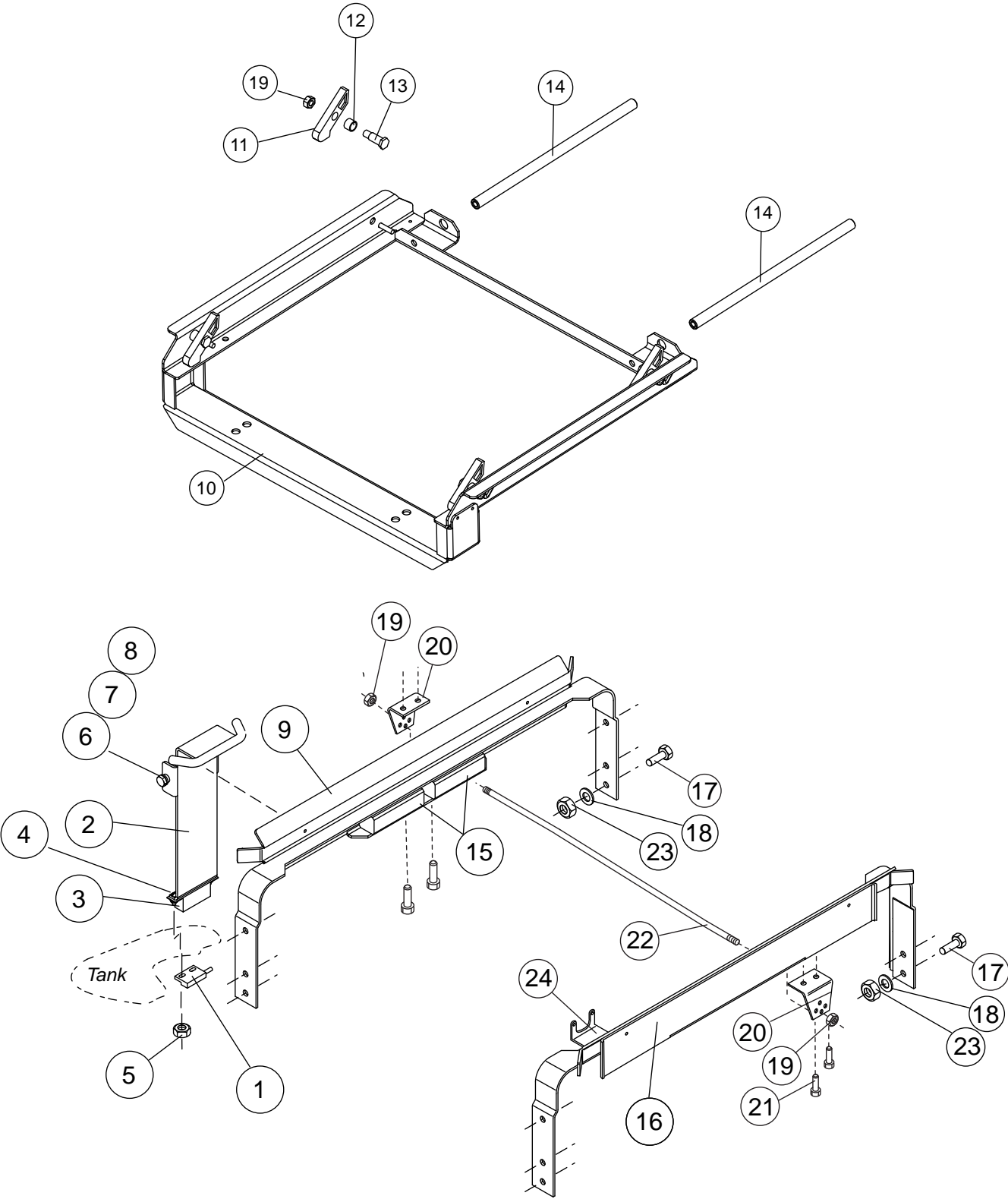

Item No.	Part No.	Description	Qty.
1	113719	Switch, Door Safety	1
2	328046	Idle Pump Switch Weldment	1
3	113937	Magnet, SS	1
4	100764	Screw, 6-32 x 1/2 Round Head SST	2
5	108954	Nut, Grip 6-32 Hex Head W/Nylon Insert	2
6	106482	Washer Lock 1/4 Split	2
7	327833	Pin Idle Pump Switch lever	1
8	100736	Bolt, 1/4-20 x 3/4" Hex Head	2
9	328041	Track, 22" PW Rear	1
10	414334	Cradle Assembly, Complete, PW22" (includes items 11, 12, 13, 19)	1
—	414438	Cradle Assembly Complete, PW36" (includes items 11, 12, 13, 19)	1
11	204513	Pawl, Cradle	4
12	206345	Spacer, Rack Cradle Pawl	4
13	113692	Bolt, Shoulder, 3/8 x 3/4 x 5/16-18 x 3/8" SST	4
14	333155	Cradle, Drive Rod Single Tank, 22" PW. 36" PW	2
15	206343	Bearing, E Cradle Support	4
16	327955	Track, 22" PW Front	1
17	100735	Bolt 1/4-20 x 5/8" Hex Head SST	8
18	112318	Washer, Flat 1/4-20	8
19	100142	Nut, Grip 5/16-18	6
20	331988	Bracket, Lower Washarm Support	2
21	100734	Bolt, Hex. Hd. 1/4-20 x 1/2"	6
22	206920	Rod, Lower Washarm Support, Threaded	1
23	100141	Nut, Grip 1/4-20	8
24	336164	Bracket, Lower Wash Support	1
—	900897	Kit, Idle Pump Assy. (Includes items 1-8)	

Single Tank Track & Cradle Assembly

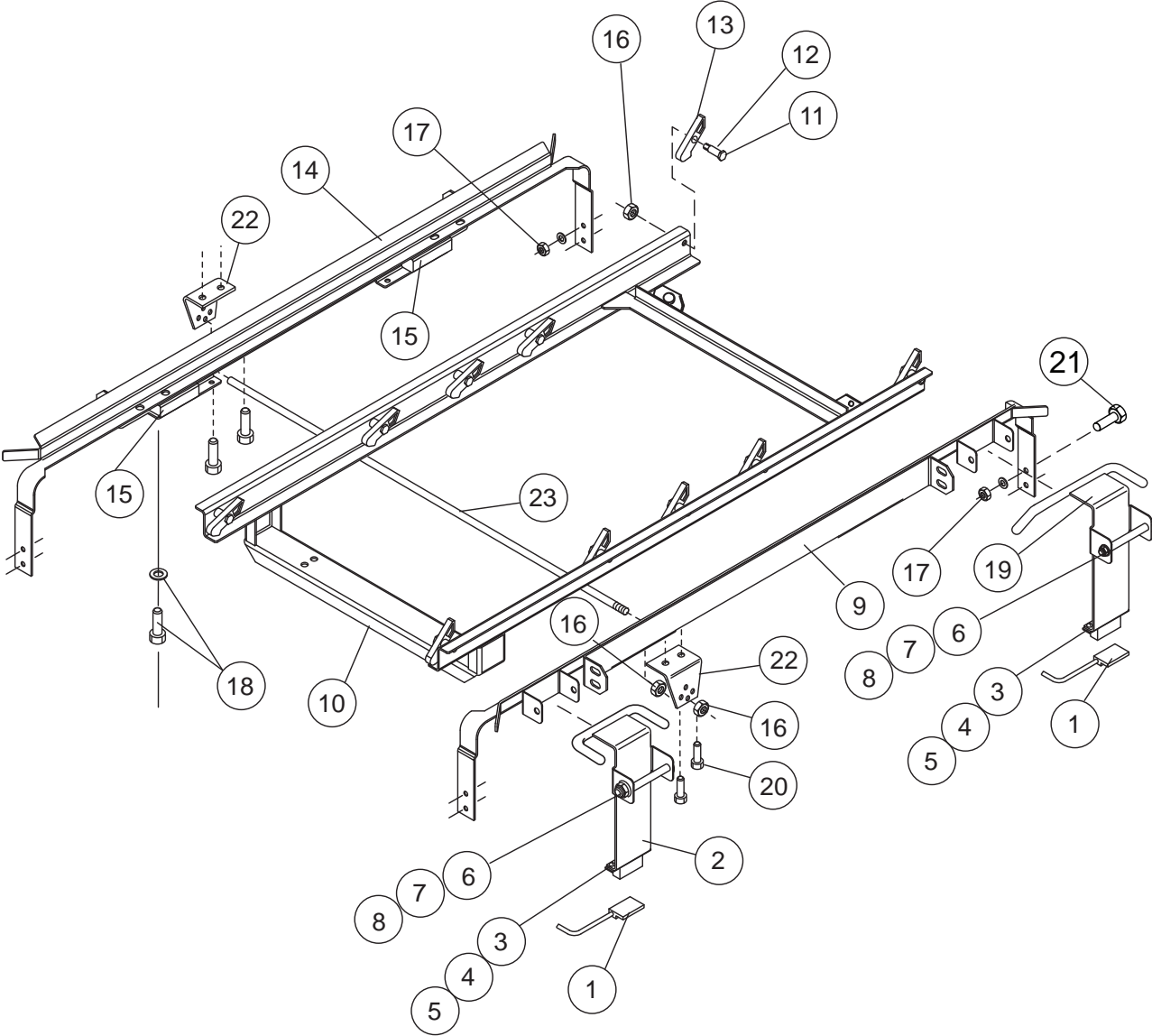

Single Tank Track & Cradle Assembly

Item No.	Part No.	Description	Qty.
1	113719	Switch, Reed Aleph	1
2	327969	Idle Pump Switch Weldment	1
3	113937	Magnet, SS	1
4	100764	Screw, 6-32 x 1/2 Round Head SST	2
5	108954	Nut, Grip 6-32 Hex Head W/Nylon Insert	2
6	106482	Washer Lock 1/4 Split	2
7	327833	Pin Idle Pump Switch	1
8	100736	Bolt, 1/4-20 x 3/4" Hex Head	2
9	414370	Track, E44 Front	1
10	414307	Cradle, E44	1
11	113692	Bolt, Shoulder 3/8 x 3/4" x 5/16-18 x 3/8"	8
12	206345	Spacer, Pawl	8
13	204513	Pawl, NG Cradle	8
14	414357	Track, E44 Rear	1
15	206343	Bearing, Rack Cradle Slide	4
16	100142	Nut, Grip 5/16-18	14
17	100141	Nut, Grip 1/4-20	4
18	100736	Bolt 1/4-20 x 3/4 Hex Head SST	2
–	106482	Washer Lock 1/4-20 Split	2
19	329283	Weldment, DR/Final Rinse Switch (L-R Machine)	1
–	329295	Weldment, DR/Final Rinse Switch (R-L Machine)	1
20	100734	Bolt, Hex. Hd. 1/4-20 x 1/2"	6
21	100735	Bolt 1/4-20 x 5/8" Hex Hd., SST	9
22	331988	Bracket Lower Washarm Support	2
23	206920	Rod, Support	1
–	415667	Cradle, Complete (Includes Items 10-13 and 16)	1
–	900897	Kit, Idle Pump Assy. (Includes Items 1-8)	A/R

Two Tank Track & Cradle Assembly

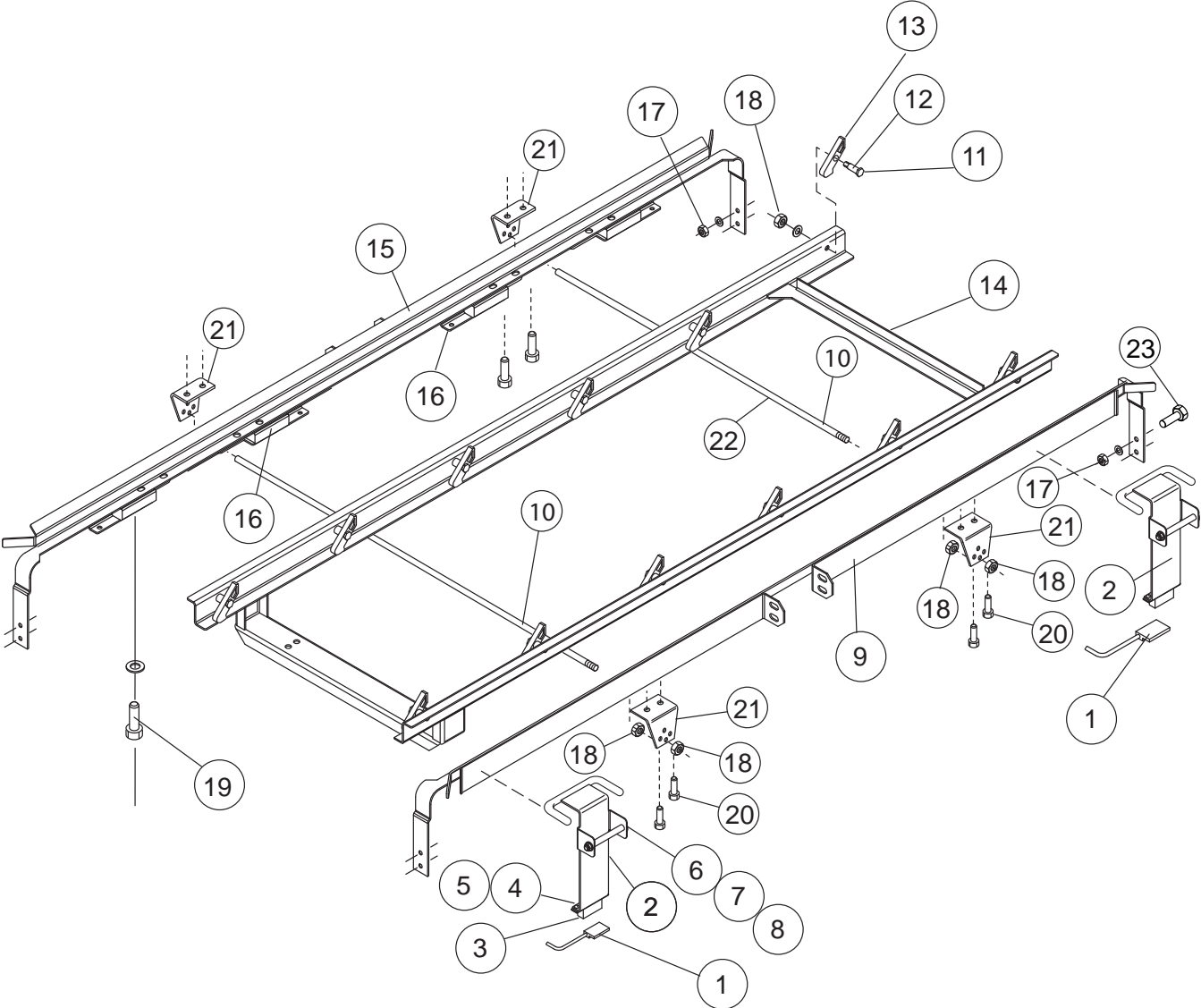

Item No.	Part No.	Description	Qty.
1	113719	Switch, Reed Aleph	1
2	327969	Idle Pump Switch Weldment	2
3	113937	Magnet, SS	1
4	100764	Screw, 6-32 x 1/2 Round Head SST	2
5	108954	Nut, Grip 6-32 Hex Head W/Nylon Insert	2
6	106482	Washer Lock 1/4 Split	2
7	327833	Pin Idle Pump Switch	1
8	100736	Bolt, 1/4-20 x 3/4 Hex Head	2
9	335471	Track, Front E64 (L-R Machine)	1
—	335472	Track, Front E64 (R-L Machine)	1
—	335474	Track, Front E84 (L-R Machine)	1
—	335475	Track, Front E84 (R-L Machine)	1
10	206920	Rod, Support	2
11	113692	Bolt Shoulder, 3/8 X 3/4 X 5-16 X 18 SST	12
12	206345	Spacer, Pawl	12
13	204513	Pawl, NG Cradle	12
14	414378	Cradle, E64 Assembly	1
—	414979	Cradle, E84 Assembly	1
15	335470	Track, Rear E64 (L-R Machine) and (R-L Machine)	1
—	335473	Track, Rear E84 (L-R Machine) and (R-L Machine)	1
16	206343	Bearing, Rack Cradle Slide (E64 Qty. 8) (E84 Qty. 12)	A/R
17	100141	Nut, Grip 1/4-20	8
18	100142	Nut, Grip 5/16-18	16
19	100736	Bolt 1/4-20 x 3/4 Hex Head SST	2
—	106482	Washer Lock 1/4-20 Split	2
20	100734	Bolt, Hex. Hd. 1/4-20 x 1/2"	8
21	331988	Bracket, Lower Washarm Support	4
22	206920	Rod, Lower Washarm Support	2
23	100735	Bolt 1/4-20 x 5/8" Hex Hd., SST	8
—	900897	Kit, Idle Pump Assy. (Includes Items 1-8)	A/R

Prewash Scrap Screens

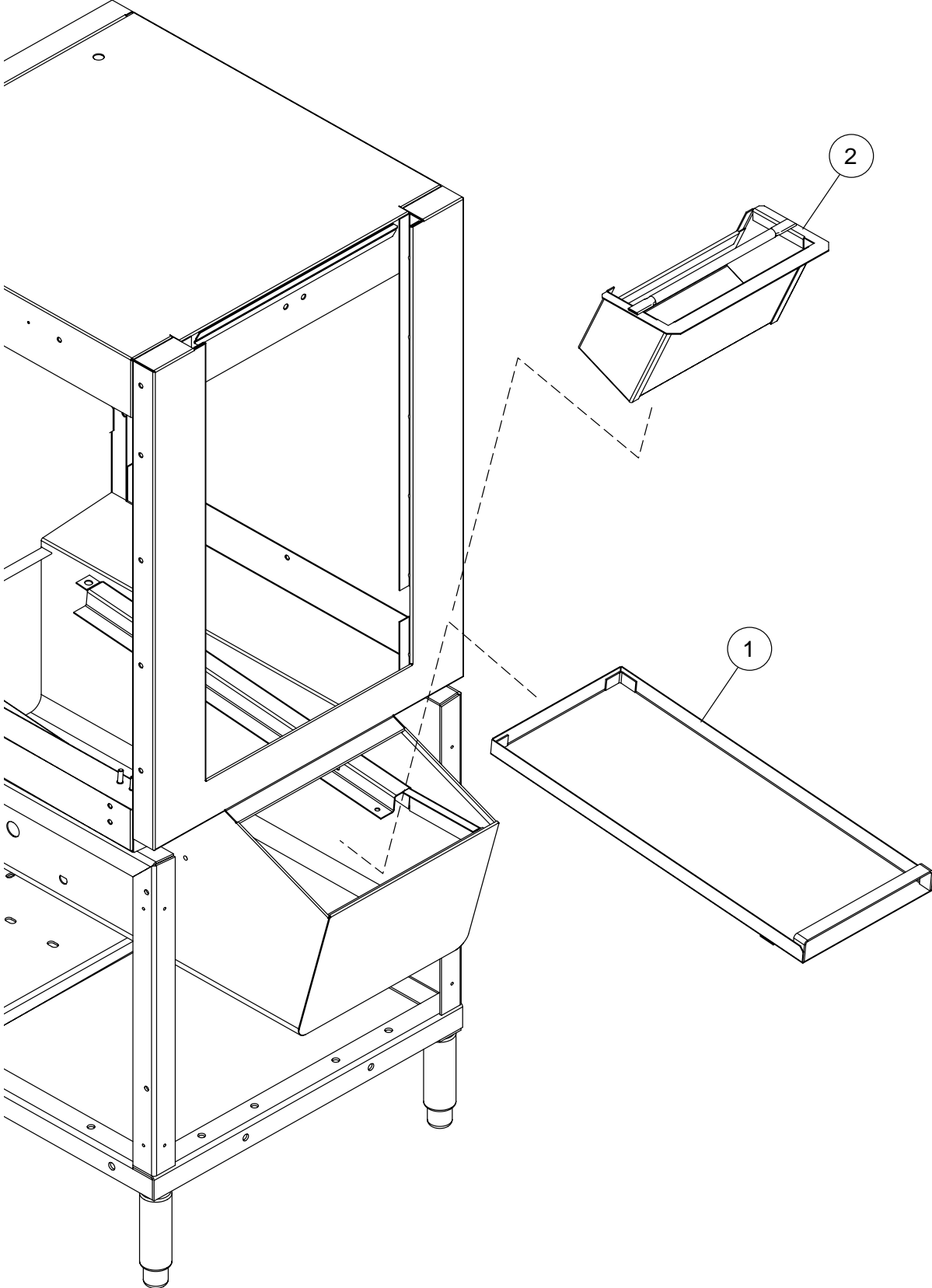

Item No.	Part No.	Description	Qty.
1	328958	Screen. Refuse 22" PW	1
–	328960	Screen, Refuse 36" PW	1
–	328958	Screen, Refuse 26" PW	1
2	328959	Basket, Refuse 22" PW	1
–	328967	Basket, Refuse 36" PW	1
–	329492	Basket, Refuse 26" PW	1

Single Tank Scrap Screens

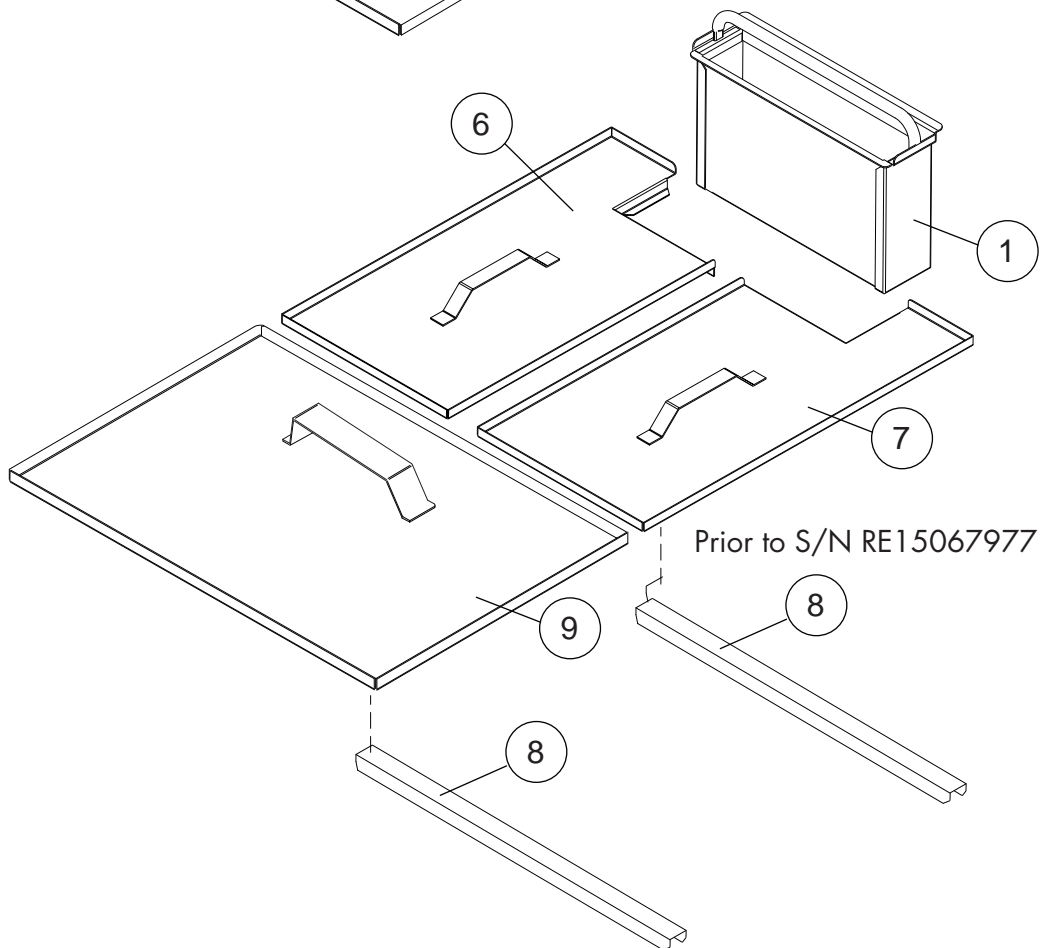
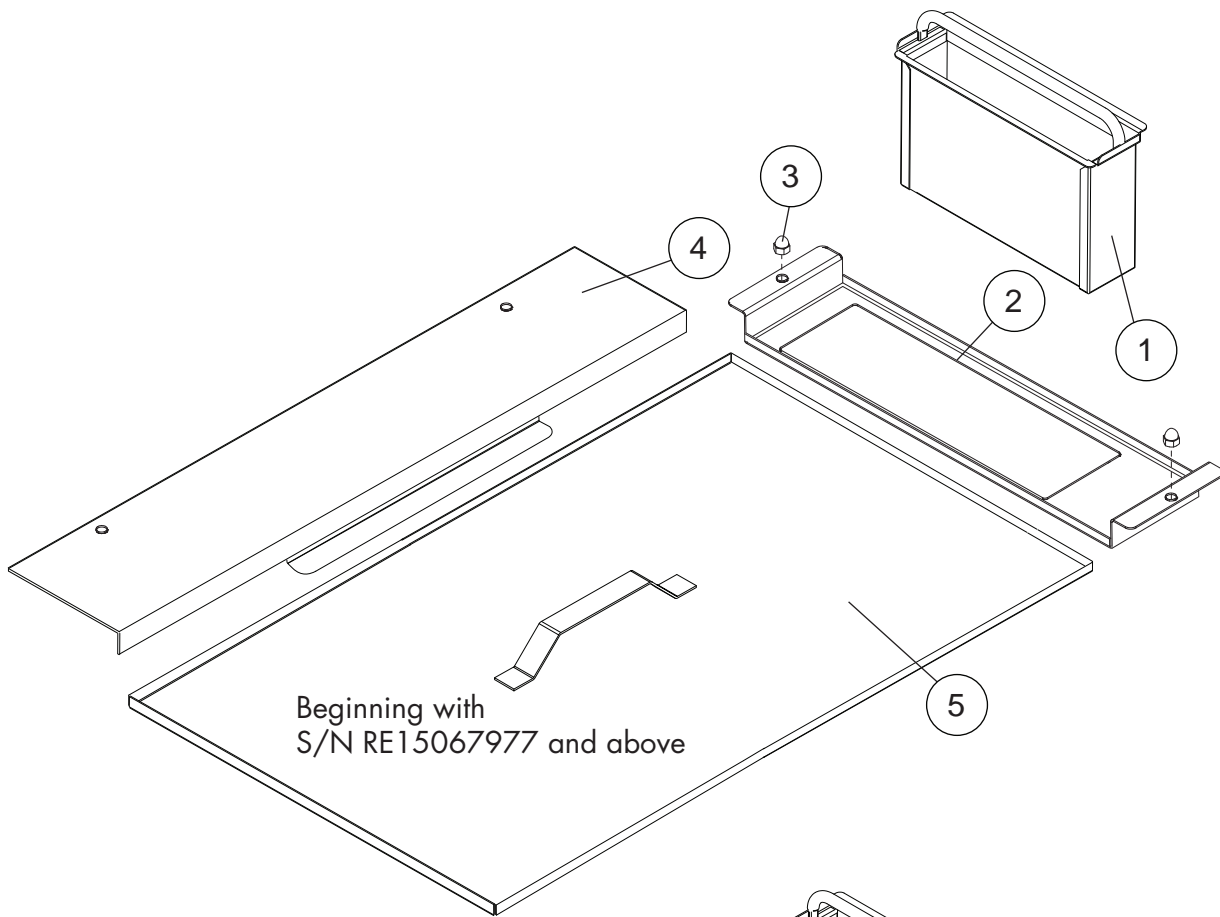

Item No.	Part No.	Description	Qty.
1	414300	Basket, Refuse (E44) <i>(All S/N's)</i>	1
2	336691	Filler, Basket <i>(Beginning with S/N RE15067977 and above)</i>	1
3	106014	Nut, Acorn 1/4-20 SST	2
4	336692	Filler, Rear (E44) <i>(Beginning with S/N RE15067977 and above)</i>	2
–	336703	Filler, Rear (E54) <i>(Beginning with S/N RE15067977 and above)</i>	2
5	336690	Screen, Scrap <i>(Beginning with S/N RE15067977 and above)</i>	1
6	414329	Screen, L-R Rear (Single Tank) <i>(Prior to S/N RE15067977)</i>	1
–	414329	Screen, R-L Front (Single Tank) <i>(Prior to S/N RE15067977)</i>	1
7	414328	Screen, Refuse L-R Front (Single Tank) <i>(Prior to S/N RE15067977)</i>	1
–	414328	Screen, Refuse R-L Rear (All Models) <i>(Prior to S/N RE15067977)</i>	1
8	331923	Support, Screen (Single Tank) <i>(Prior to S/N RE15067977)</i>	2
9	328653	Screen, Outboard, (E54DR Only) <i>(Prior to S/N RE15067977)</i>	1

Two Tank Scrap Screens

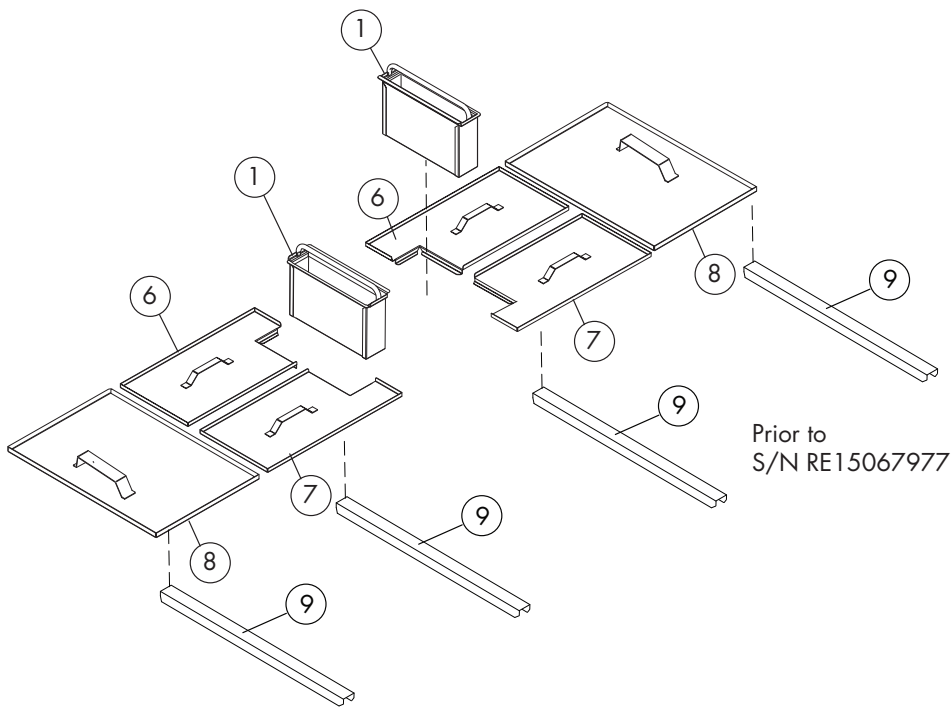
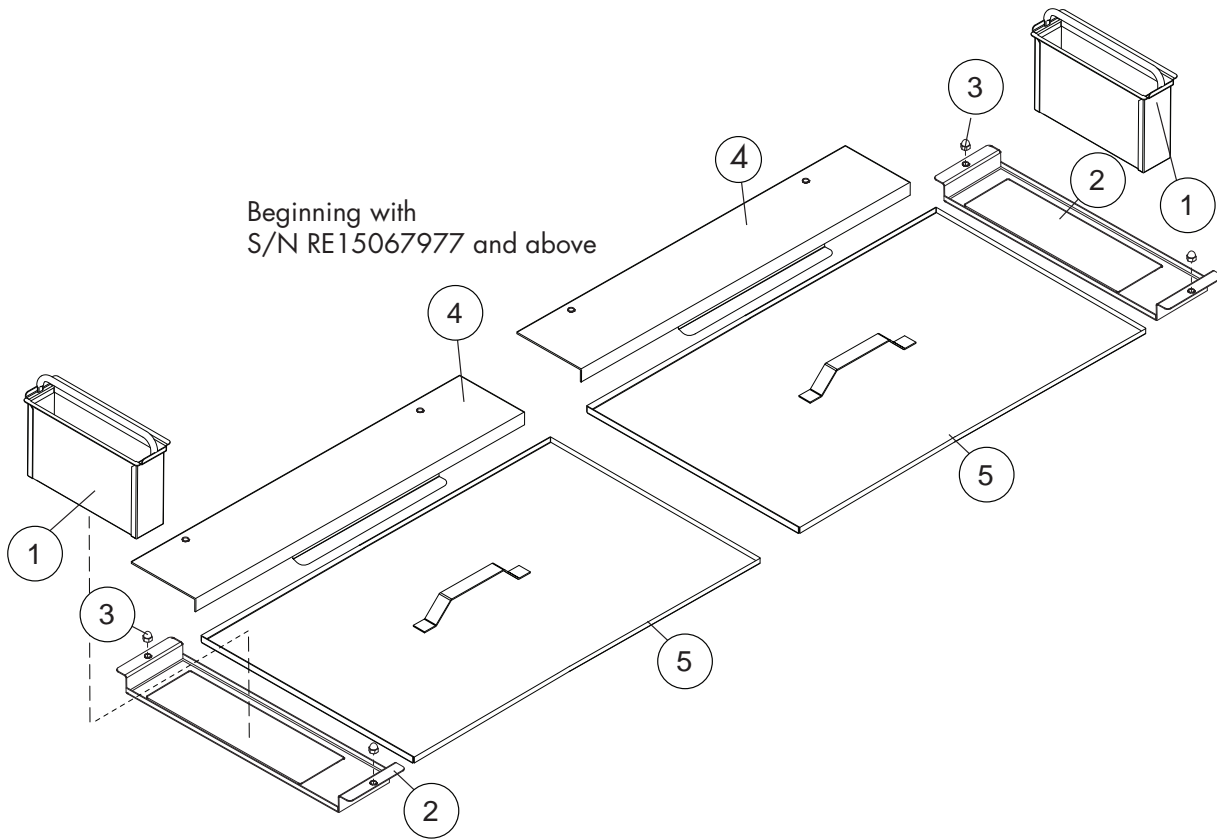

Item No.	Part No.	Description	Qty.
1	414300	Basket, Refuse (All Models)	1
2	336691	Filler, Basket <i>(Beginning with S/N RE15067977 and above)</i>	2
3	106014	Nut, Acorn 1/4-20 SST	2
4	336692	Filler, Rear (E64) <i>(Beginning with S/N Re15067977 and above)</i>	2
–	336703	Filler, Rear (E84) <i>(Beginning with S/N Re15067977 and above)</i>	2
5	336690	Screen, Scrap <i>(Beginning with S/N Re15067977 and above)</i>	2
6	414329	Screen, L-R Rear (All Models)	1
–	414329	Screen, R-L Front (All Models)	1
7	414328	Screen, Refuse L-R Front (All Models)	1
–	414328	Screen, Refuse R-L Rear (All Models)	1
8	328653	Screen, Outboard, (E84 Only)	1
9	331923	Support, Screen	2

Prewash Spray Arms

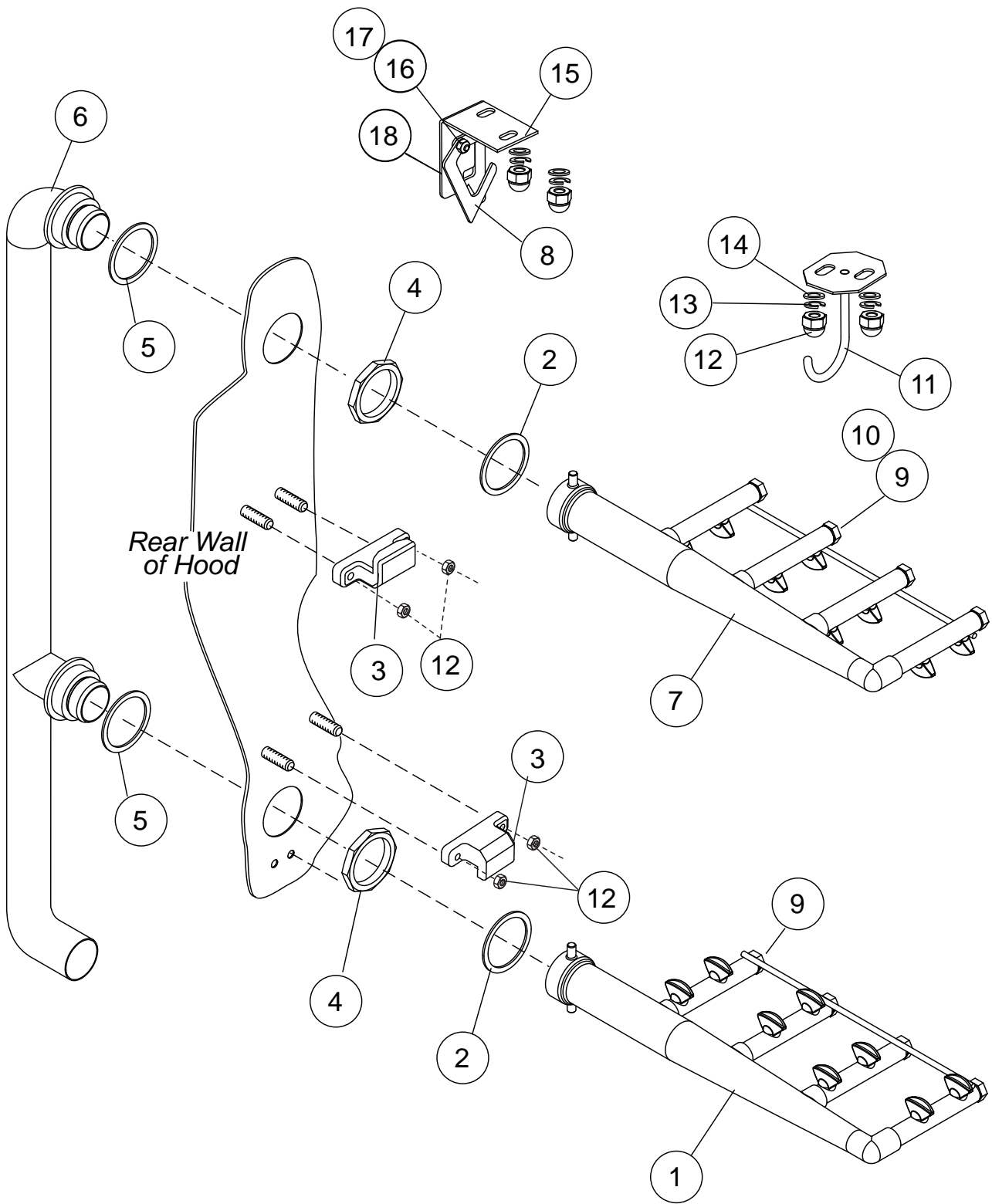

Item No.	Part No.	Description	Qty.
1	414569	Wash Manifold Assembly 6" Lower (E22" and E36")	1
2	113723	O-Ring	1
3	113738	Block, Washarm Retaining	4
4	113540	Locknut 2NPT SST	2
5	113741	Gasket, Flat EDPM 2-3/8 ID	2
6	328028	Standpipe, 22" PW	1
7	414568	Wash Manifold Assy 6" Upper E22"	1
–	414567	Wash Manifold Assy. 10" Upper E36"	1
8	328998	Bracket, Upper Safety	1
9	113555	Plug, Wash Arm E-Series (Qty per arm)	4
10	113716	O-ring	4
11	328034	Support, Upper Wash	1
12	106014	Nut, Acorn 1/4-20 SST	8
13	106482	Washer, Lock 1/4" Split SST	8
14	106026	Washer, Flat 1/4" SST	8
15	329000-1	Bracket, Support	1
16	100141	Grip Nut, 1/4" SST	2
17	100735	Bolt, Hex Hd. 1/4-20 SST	2
18	329001	Support, Upper Wash	1

Single Tank Wash Spray Arms

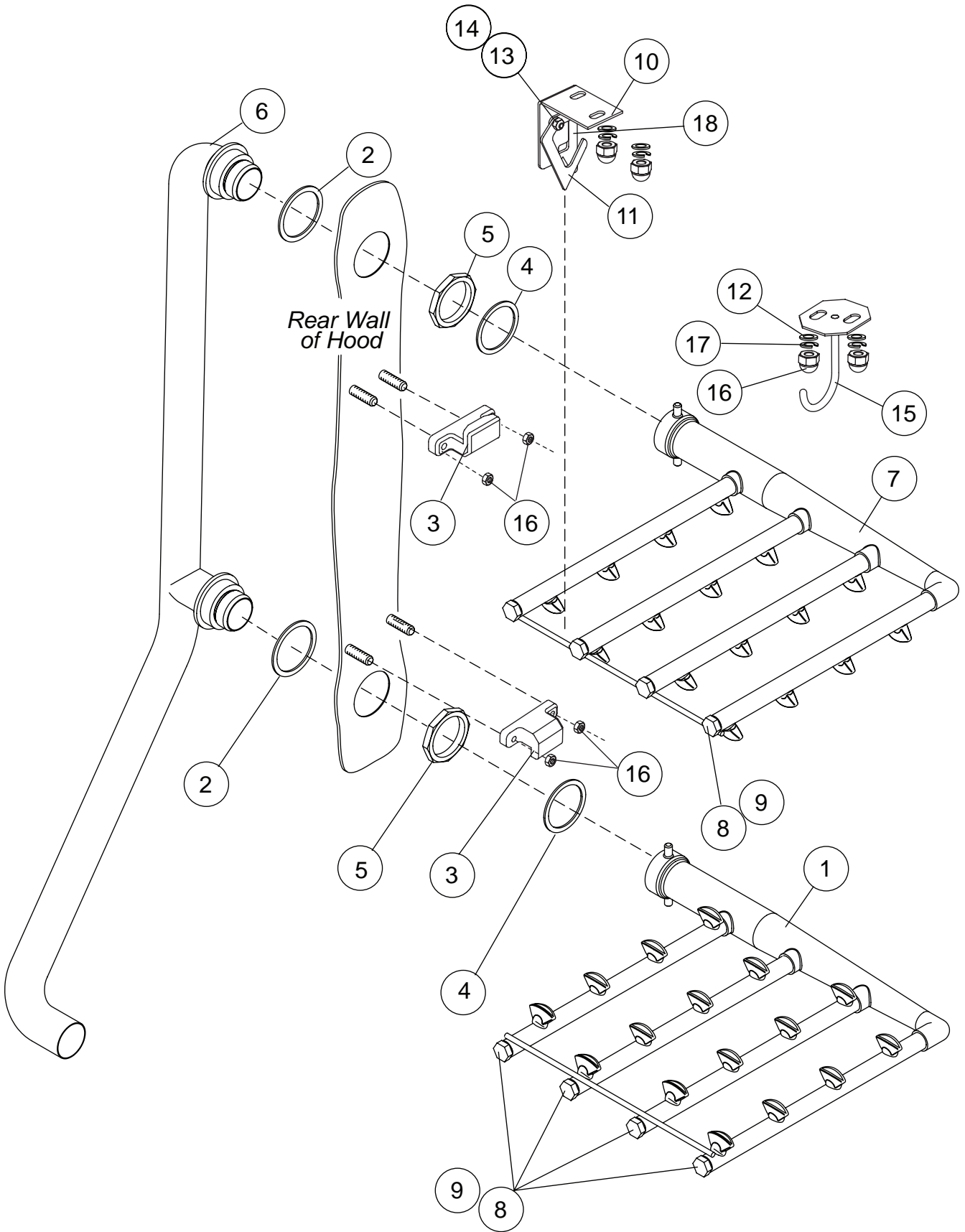

Single Tank Wash Spray Arms

Item No.	Part No.	Description	Qty.
1	414567	Wash Manifold Assembly 10" 15° Lower (L-R)	1
–	414566	Wash Manifold Assembly 10" 15° Lower (R-L)	1
2	113741	Gasket, Flat EDPM 2-3/8 ID	2
3	113738	Block, Washarm Retaining	2
4	113723	O-ring	2
5	113540	Locknut 2NPT SST	2
6	327993	Standpipe, R-L 44	1
–	414317	Standpipe, L-R 44	1
7	414565	Wash Manifold Assy 14" Straight Upper (L-R)	1
–	414564	Wash Manifold Assy 14" Straight Upper (R-L)	1
8	113555	Plug, Wash Arm E-Series (Qty per arm)	4
9	113716	O-ring	4
10	329001	Bracket, Upper Wash arm support	1
11	328998	Bracket, Upper Safety Catch	1
12	106026	Washer, Flat 1/4" SST	4
13	100141	Grip Nut, 1/4-20 SST	10
14	100736	Bolt, Hex Hd. 1/4-20 x 3/4" SST	10
15	328034	Support, Upper Wash	1
16	106014	Nut, Acorn 1/4" SST	8
17	106482	Washer, Lock 1/4" Split SST	4
18	329000-1	Latch, E Upper Washarm Weldment (L-R Operation)	1
–	329000-2	Latch, E Upper Washarm Weldment (R-L Operation)	1

Two Tank Wash & Power Rinse Spray Arms

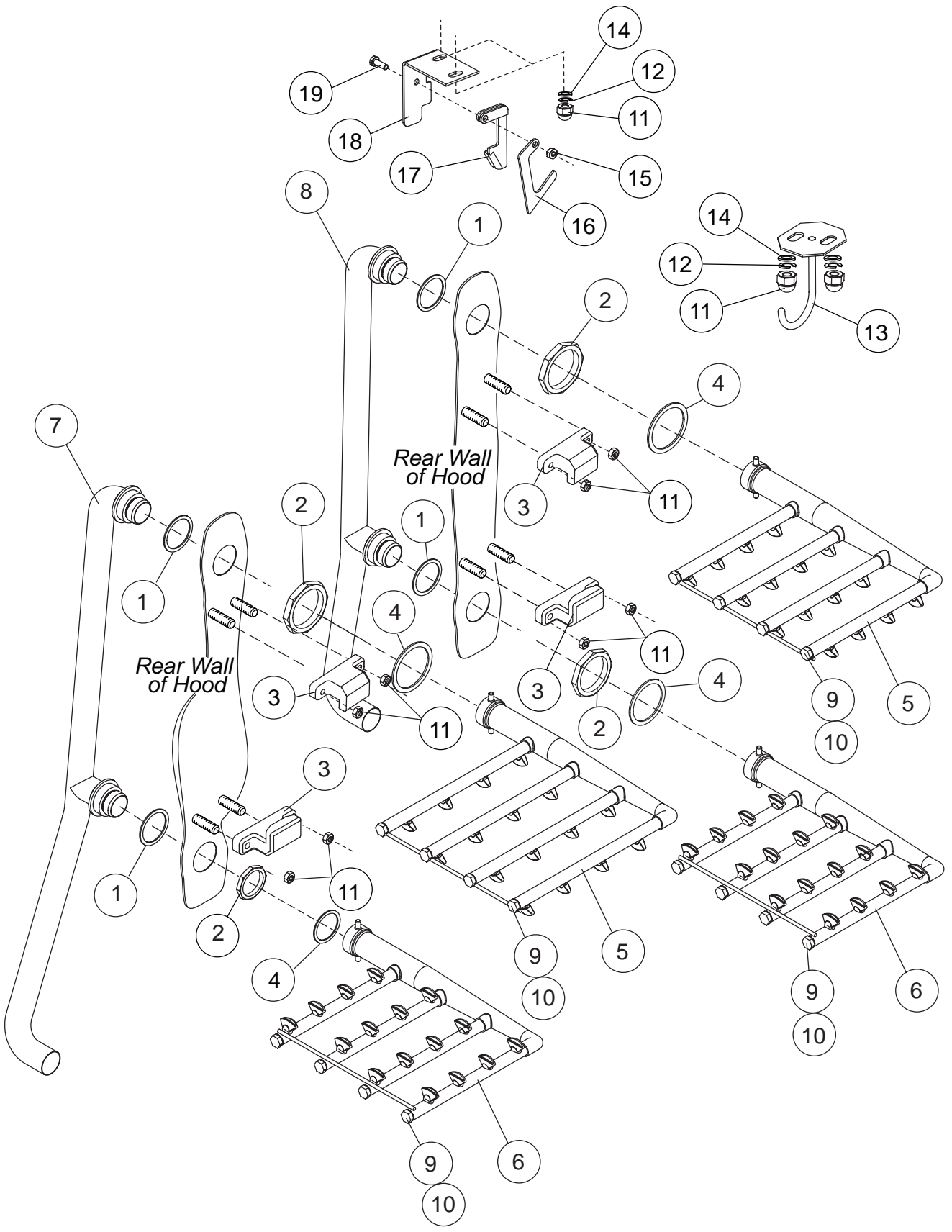

Two Tank Wash & Power Rinse Spray Arms

Item No.	Part No.	Description	Qty.
1	113741	Gasket, Flat EDPM 2-3/8 ID	4
2	113540	Locknut 2NPT SST	4
3	113738	Block, Washarm Retaining	2
4	113723	O-ring	2
5	414565	Wash Manifold Assembly 14" Straight Upper (L-R)	2
–	414564	Wash Manifold Assembly 14" Straight Upper (R-L)	2
–	414565	Wash Manifold Assy. E84 (L-R)	2
–	414564	Wash Manifold Assy. E84 (R-L)	2
6	414567	Wash Manifold Assembly 10" 15° Lower (L-R)	2
–	414566	Wash Manifold Assembly 10" 15° Lower (R-L)	2
–	414564	Wash Manifold Assy. E84 (L-R)	2
–	414565	Wash Manifold Assy. E84 (R-L)	2
7	414318	Standpipe 64 L-R Wash	1
–	328443	Standpipe 64 R-L Wash	1
8	414319	Standpipe 64 L-R Rinse	1
–	328445	Standpipe 64 R-L Rinse	1
9	113555	Plug, Wash Arm E-Series (Qty per arm)	4
10	113716	O-ring	4
11	106014	Nut, Acorn 1/4" SST	10
12	106482	Washer, 1/4" Split SST	8
13	328034	Support, Upper Washarm	2
14	106026	Washer, Flat 1/4" SST	8
15	100141	Grip Nut, 1/4" SST	4
16	328998	Bracket, Upper Safety	2
17	329000-1	Latch, E Upper Washarm Weldment (L-R Operation)	2
–	329000-2	Latch, E Upper Washarm Weldment (R-L Operation)	2
18	329001	Bracket, Upper Washarm Support	2
19	100736	Bolt, Hex Hd. 1/4-20 x 3/4" SST	4

Dual Rinse (DR) Tank Assembly

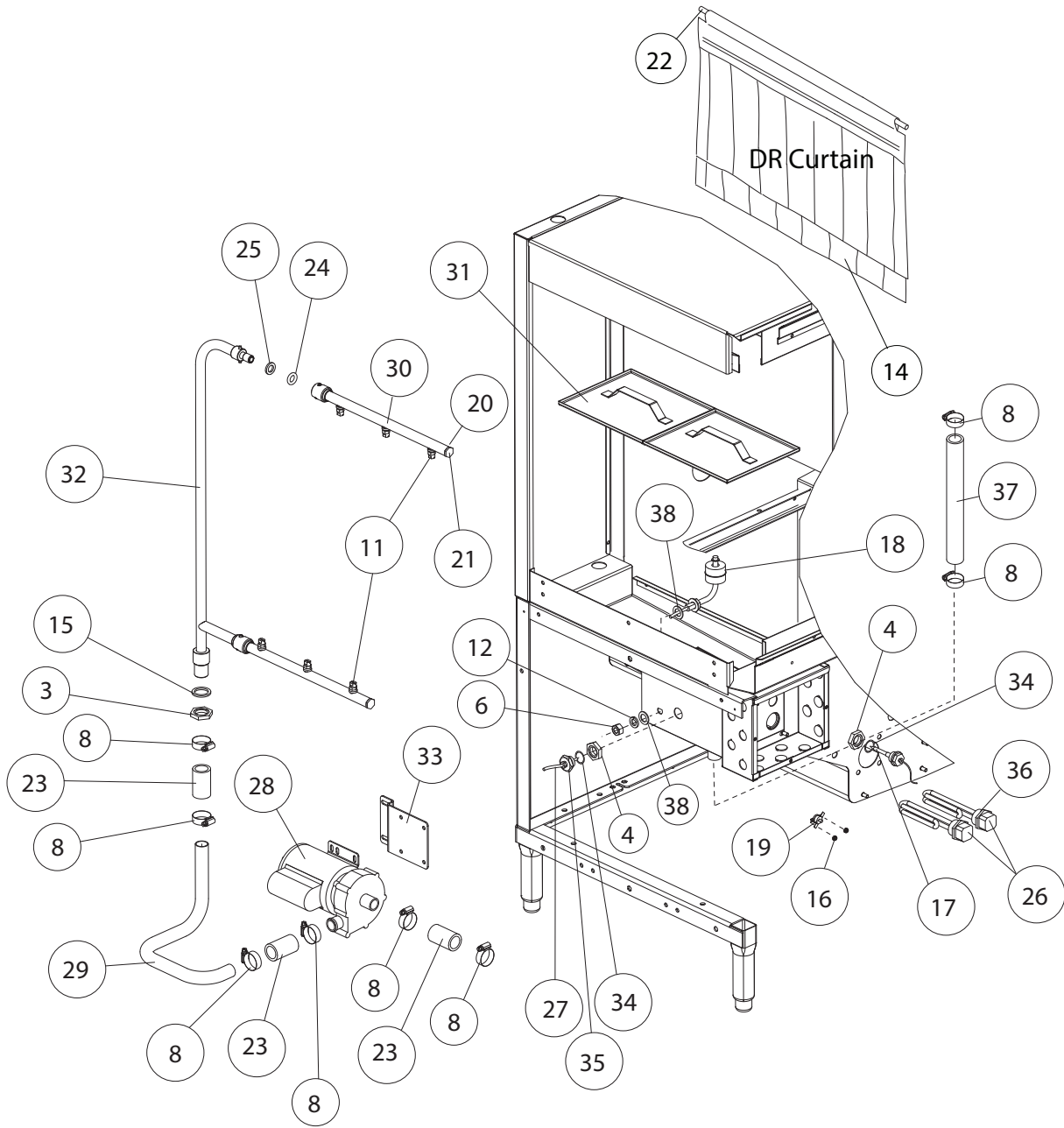

L-R Direction Shown

Dual Rinse (DR) Tank Assembly

Item No.	Part No.	Description	Qty.
1	100003	Nut, Hex Plain 1/4-20 SST	4
2	100097	Screw, Truss Head, 10-32 x 1/2" SST	2
3	100156	Locknut, 3/4" NPT Brass	1
4	100547	Locknut, 1/2" NPT SST	2
5	100735	Bolt, Hex Head, 1/4-20 x 5/8" SST	4
6	104584	Nut, Hex Plain 1/2-13 SST	1
7	104882	Washer, Flat 1/2" SST	1
8	105993	Clamp, Hose M20 Gear-type	8
9	106026	Washer, Flat 1/4" SST	4
10	106482	Washer, Lock 1/4" Split SST	4
11	107290	Nozzle, 1/8" HU-SS 8015	6
12	107589	Washer, Lock 1/2" Split SST	1
13	107966	Nut, Hex Grip 10-32 SST w/nylon insert	2
14	108043	Curtain, 24" x 13-1/4"	1
15	108620	Gasket, Rinse Manifold, 3/4" Piping	1
16	108954	Nut, Hex Grip 6-32 SST w/nylon insert	2
17	109069	Thermostat, Control with Capillary	1
18	115352	Switch, Float	1
19	113604	Thermostat, High Limit Fixed Snap 212°F	1
20	113716	O-ring, Plug Rinse	2
21	113795	Plug, Rinse Manifold	2
22	114012	Rod, Curtain 5/16" x 23-1/2" Lg.	1
23	114021	Hose, 1" ID x 2-1/4" Lg.	3
24	114290	O-ring	2
25	114291	Washer, Rubber	2
26	114420	Heater, 1.5KW 200/220V/60/1, includes O-ring	2
—	114421	Heater, 1.5KW 230/20V/1, includes O-ring	2
—	114422	Heater, 1.5KW 460/480V/1, includes O-ring	2
—	114423	Heater, 1.5KW 575V/1, includes O-ring	2
27	114435	Thermistor, 10KΩ, 36" Lead	1
28	115231	Pump Assy., Auxillary Rinse 115/60/1	1
29	207231	Tube, Pump Discharge	1
30	329009	Tube, Weldment, LWR. Horizontal	2
31	332170	Screen, Scrap DR	2
32	332211	Manifold, Auxillary Rinse	1
33	334900	Bracket, Pump Support	1
34	115498	O-ring	1
35	0512299	Adapter	1
36	0503588	O-ring	2
37	115230	Hose, DR Drain	1
38	104882	Washer, Flat 1/2"	2

Dual Rinse (DR) Pump/Motor Assembly

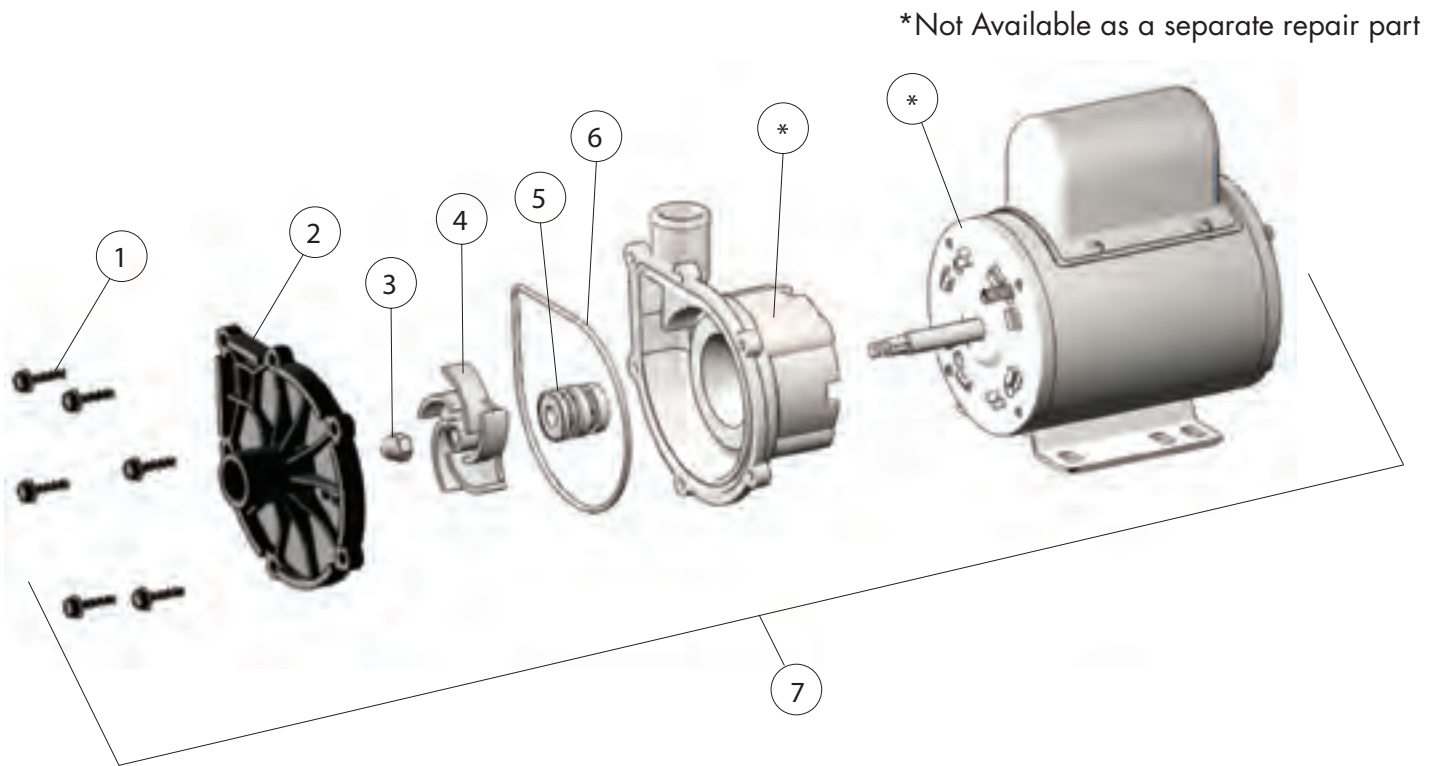

Dual Rinse (DR) Pump/Motor Assembly

Item No.	Part No.	Description	Qty.
1	115231-1	Screw, Self-tapping Washer Head	6
2	115231-2	Cover, Polypropylene	1
3	115231-3	Nut, Acorn 1/4-20 SST	1
4	115231-4	Impeller, DR Pump SST	1
5	115231-5	Seal, Pump 3/8" Type 16 SST	1
6	115231-6	O-ring	1
7	115231	Pump Assy., Auxillary Rinse 115/60/1 (Includes all items)	1

Prewash Pump Suction & Discharge

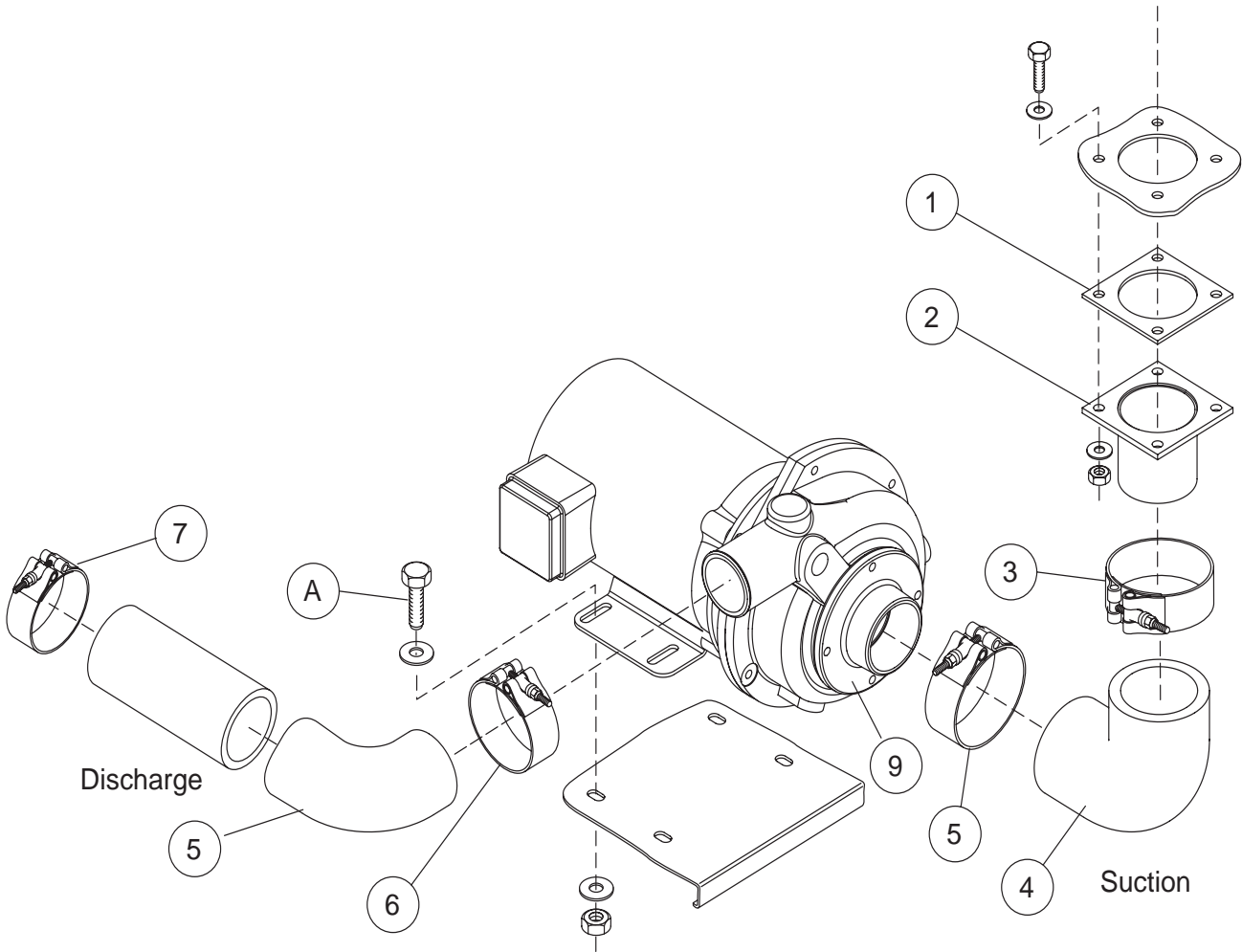

L-R Application Shown

Prewash Pump Suction & Discharge

Item No.	Part No.	Description	Qty.
1	109568	Gasket Pump Suction	1
2	307995	Flange, Suction	1
3	104203	Clamp, Hose M52 SST	2
4	113717	Hose, PW Suction	1
5	113731	Hose 22" PW Pump Discharge	1
6	104165	Clamp, Hose M40 SST	1
7	111964	Hose, Clamp Discharge	1
8	311761	Strainer, Pump Suction (Not Shown)	1
9	113636	Suction, Flange Machined	1
10	112338	Gasket Pump Suction Flange (Not Shown)	1

A

Pump Fasteners

100739	Bolt 5/16-18 x 3/4 Hex Head SST	4
102376	Washer 5/16 x 3/4 x 1/16	8
109009	Nut, Grip 5/16 w/Nylon Insert	4

Wash & Power Rinse Pump Suction/Discharge

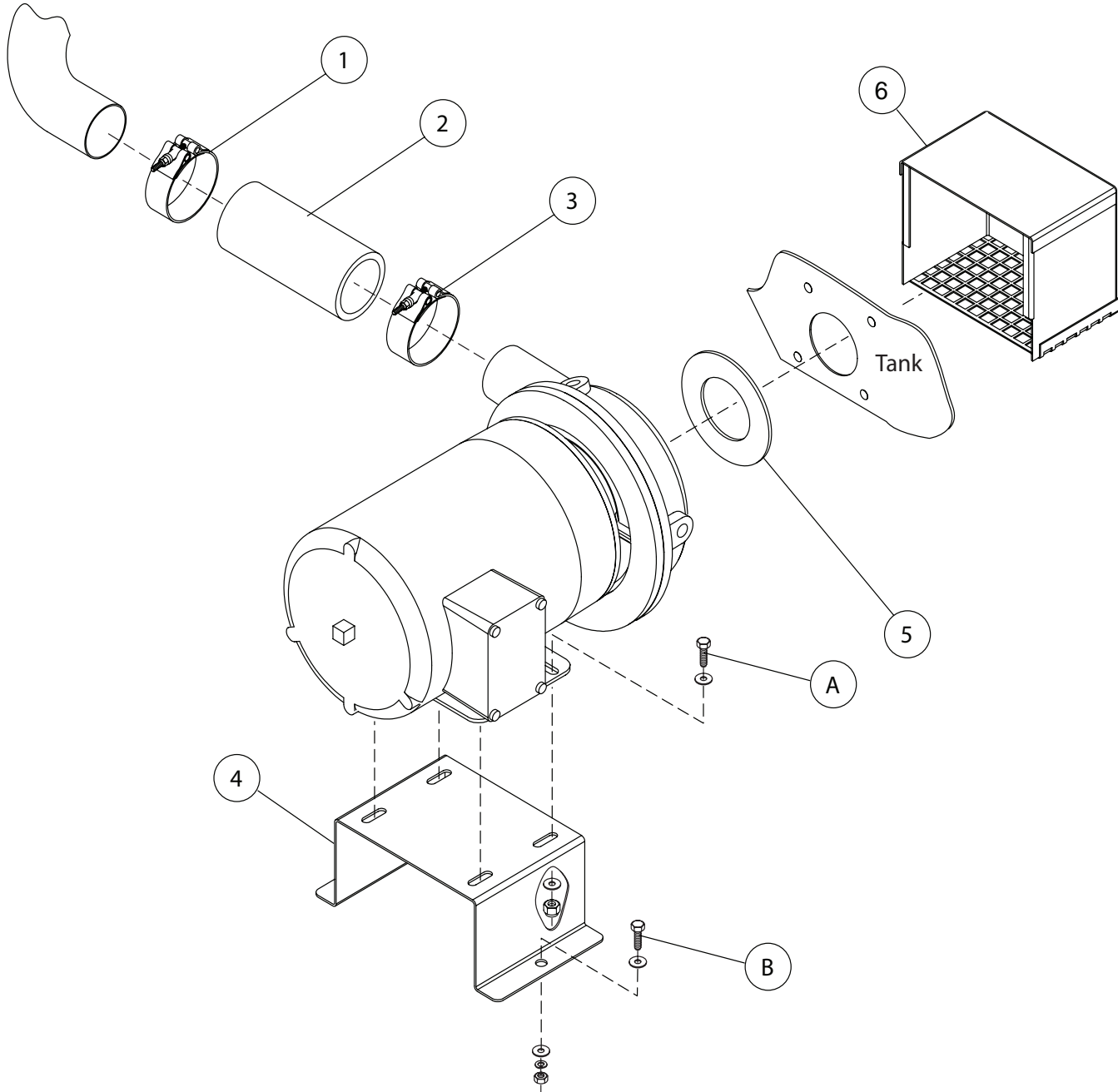

Wash & Power Rinse Pump Suction/Discharge

Item No.	Part No.	Description	Qty.
1	110858	Hose Clamp Pump Discharge	1
2	113984	Hose Discharge Pump	1
3	111780	Hose Clamp Discharge	1
4	327997	Pump Motor Base	1
5	113538	Gasket Pump Suction	1
6	327904	Screen Pump Suction	1
A		Pump Base Fasteners	
	100739	Bolt 5/16-18 x 3/4 Hex Head SST	4
	102376	Washer 5/16 x 3/4 x 1/16	8
	109009	Nut Grip 5/16 w/Nylon Insert	4
B		Pump Fasteners	
	100739	Bolt 5/16-18 x 3/4 Hex Head SST	4
	102376	Washer 5/16 x 3/4 x 1/16	8
	109009	Nut, Grip 5/16 w/Nylon Insert	4

Pump/Motor Assembly

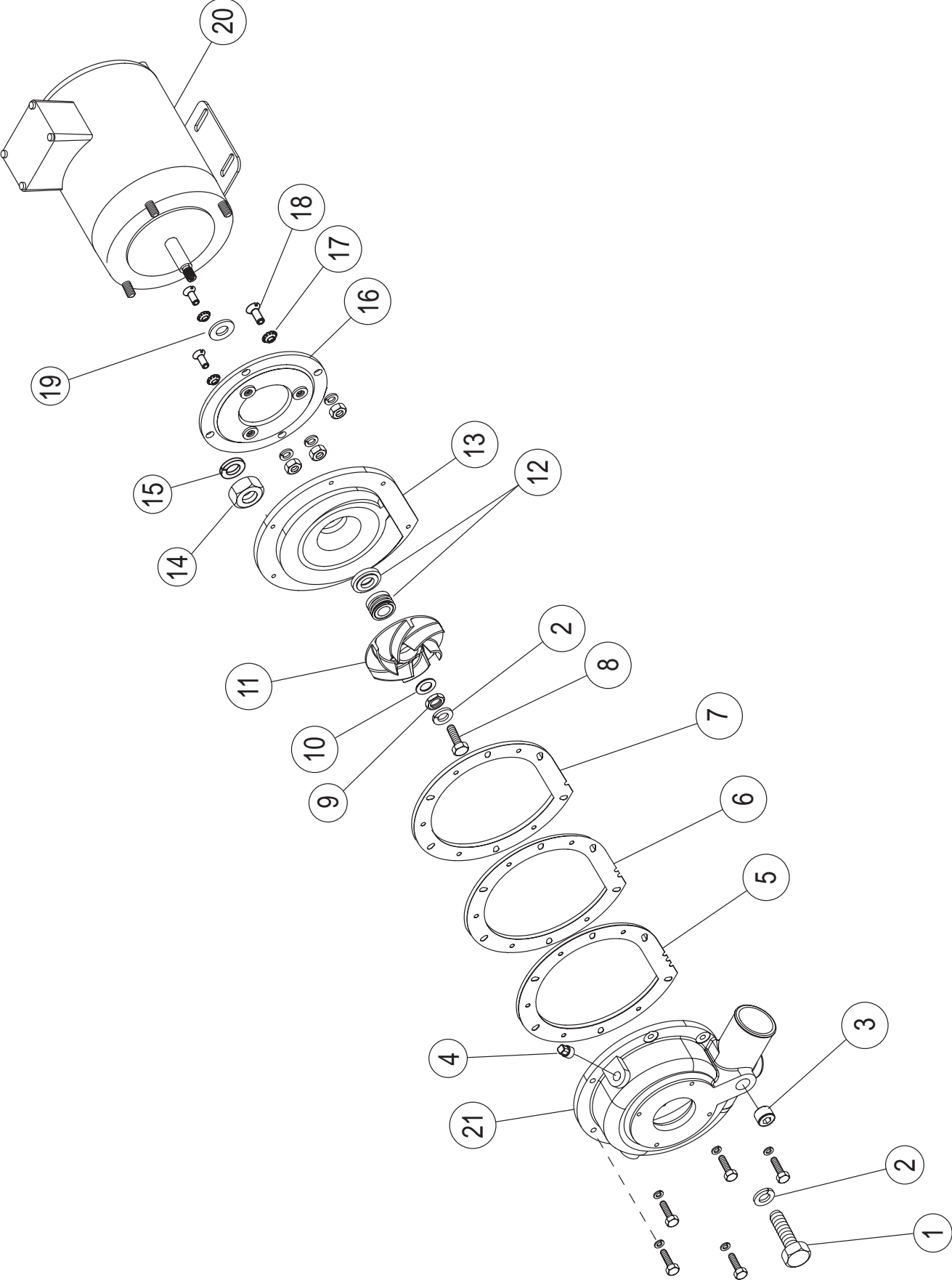

Item No.	Part No.	Description	Qty.
1	100736	Bolt 1/4-20 x 3/4 Hex Head	6
2	106482	Washer, Lock 1/4"	10
3	113705	Plug 1/2" NPT Countersunk Brass (2HP) (Wash/Rinse)	1
3	102504	Plug 1/2" NPT Brass Sq Head (1HP) (Prewash)	1
4	102500	Plug 1/4" NPT Brass	2
5	111943	Gasket .032 Thk (3 Notches)	1
6	111942	Gasket .015 Thk (2 Notches)	1
7	111941	Gasket .0085 Thk (1 Notch)	1
8	100735	Bolt 1/4-20 x 5/8 Hex Head	1
9	110247	Nut Jam Hex 7/16-20 SST	1
10	110248	Washer .44OID x .043SST	1
11	113118	Impeller 1HP, SST Machined (Prewash)	1
-	113603	Impeller 2HP SST Machined (Wash/Rinse)	1
-	113120	Impeller 3HP, SST	1
12	111111	Seal Pac Type 16	1
13	113635	Flange, Jet Pump, SST NG	1
14	107690	Nut, Jam 3/8-16	4
15	106407	Washer, Lock 3/8 Split	4
16	204460	Backing Plate 1HP, 2HP, 3HP	1
17	110270	Washer, C-Sunk, Ex-Tooth SST	3
18	100754	Screw 10-32 x 1/2 Flat Head	3
19	109654	Slinger-Water	1
20	110419	Motor 1HP MV/60/1 (Prewash)	1
-	110421	Motor 2HP MV/60/1 (Prewash)	1
-	110420	Motor 1HP MV/60/3 (Prewash)	1
-	111739	Motor 1HP 575/60/3 (Prewash)	1
-	115587	Motor 2HP MV/60/3 (Wash/Rinse)	1
-	111740	Motor 2HP 575/60/3 (Wash/Rinse)	1
-	110424	Motor 3HP MV/60/3 (Wash/Rinse)	1
-	111741	Motor 3HP 575/60/3 (Wash/Rinse)	1
21	113634	Pump Volute SST Machined (Prewash/Wash/Rinse)	1
-	112338	Gasket, Pump Suction Flange (Not Shown)	1
-	900737	Kit*Gaskets, Jet Pump (Includes Items 5-7)	A/R
-	900183	Kit*Seal & 1HP Impeller (Includes Items 5-7, 11 and 12)	A/R
-	900185	Kit*Seal & 3HP Impeller (Includes Items 5-7, 11 and 12)	A/R

Complete Pump Assemblies:

415531	1HP PW 115-240/1/60	415918	2HP LH 575/3/60
414965	1HP PW 208-480/3/60	414821	2HP RH 115-240/1/60
415917	1HP PW 575/3/60	414374	2HP RH 208-480/3/60
415743	2HP PW 115-240/1/60	416243	2HP RH 220/380/3-50
415744	2HP PW 208-480/3/60	415919	2HP RH 575/3/60
415745	2HP PW 575/3/60	414977	3HP LH 208-480/3/60
414820	2HP LH 115-240/1/60	415920	3HP LH 575/3/60
414373	2HP LH 208-480/3/60	414978	3HP RH 208-480/3/60
		415921	3HP RH 575/3/60

LH and RH indicate on which side of the machine the pump is located.



Pump Configurations

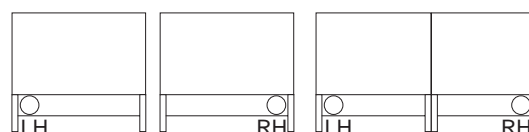

Float Switches

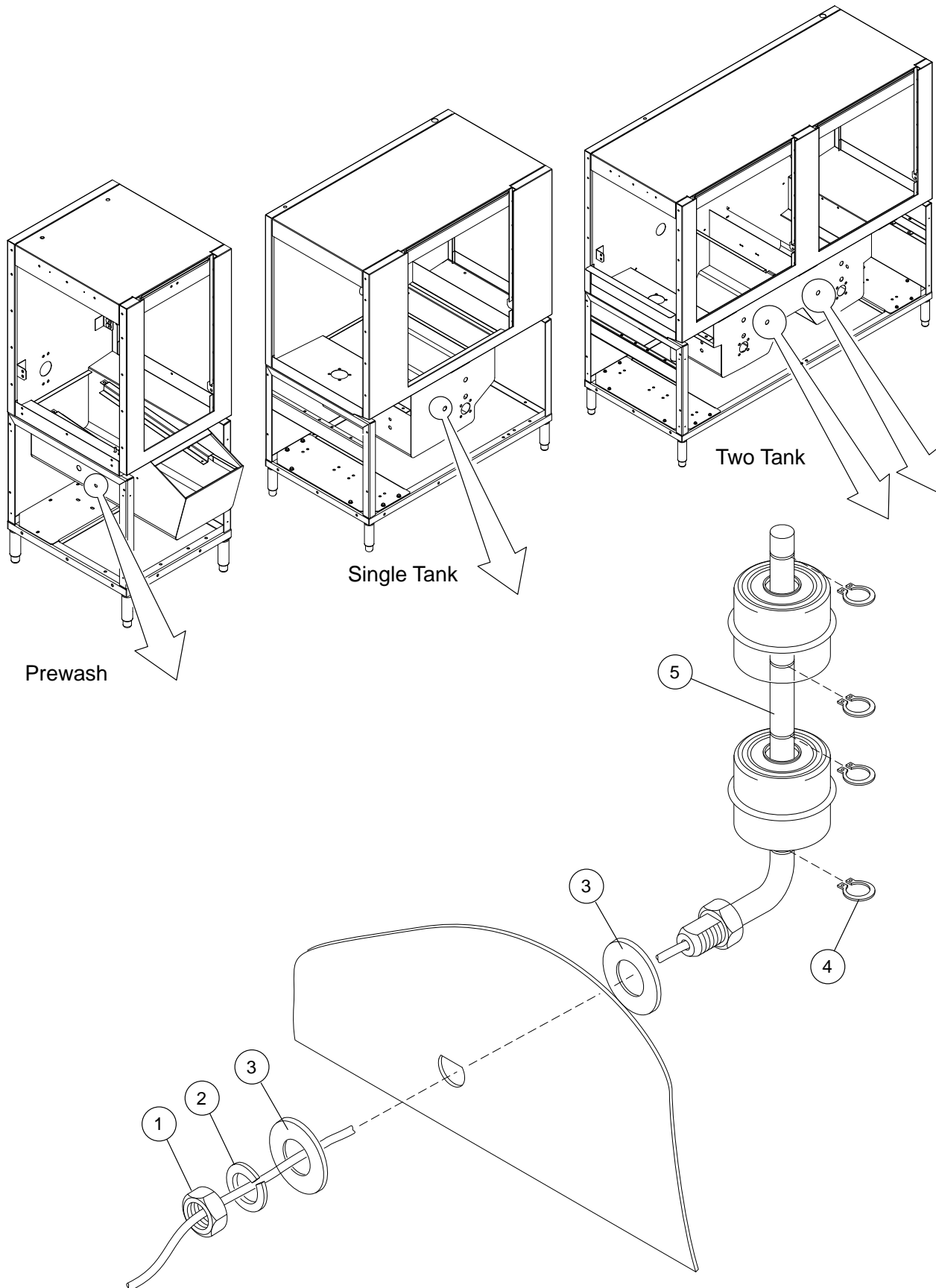

Item No.	Part No.	Description	Qty.
1	104584	Nut, Plain 1/2-13	1
2	107589	Washer, Lock 1/2"	1
3	104882	Washer, Flat 1/2"	2
4	111151	C-Clip	A/R
5	110854	Float Switch, Dual, Prewash	1
-	113291	Float Switch, Dual, Wash, Single Tank	1
-	113291	Float Switch, Dual, Wash/Power Rinse, Two Tank	2
-	110750	Gasket, Float Switch (Not Shown)	A/R

Single Tank Electric Wash Tank Heat

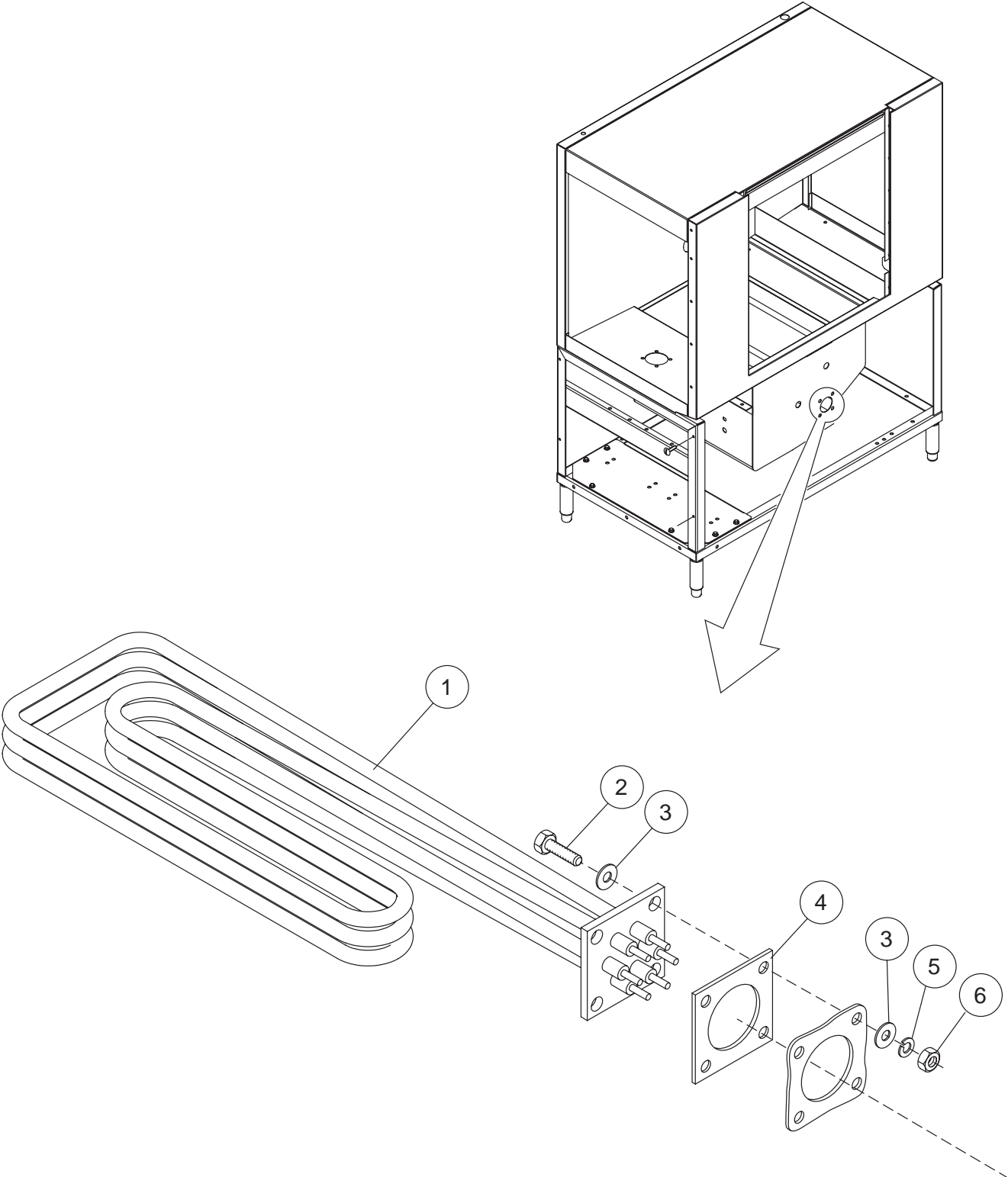

Single Tank Electric Wash Tank Heat

Item No.	Part No.	Description	Qty.
1	113516	Heater 15/18KW 200V- 220V, 380V	1
–	113517	Heater 15/16.3KW 230- 240V, 400- 415V	1
–	113518	Heater 15/16.3KW 460- 480V	1
–	113519	Heater 15KW 575V	1
2	100153	Bolt, 3/18-16 x 1 Hex Head	4
3	104618	Washer 3/8 x 7/8 x 1/16 SST	8
4	108345	Gasket 3 x 3 x 1/8" 2" Hole	1
5	106407	Washer Lock 3/8 Split	4
6	100140	Nut Plain 3/8-16	4

Two Tank Electric Wash Tand Rinse Tank Heat

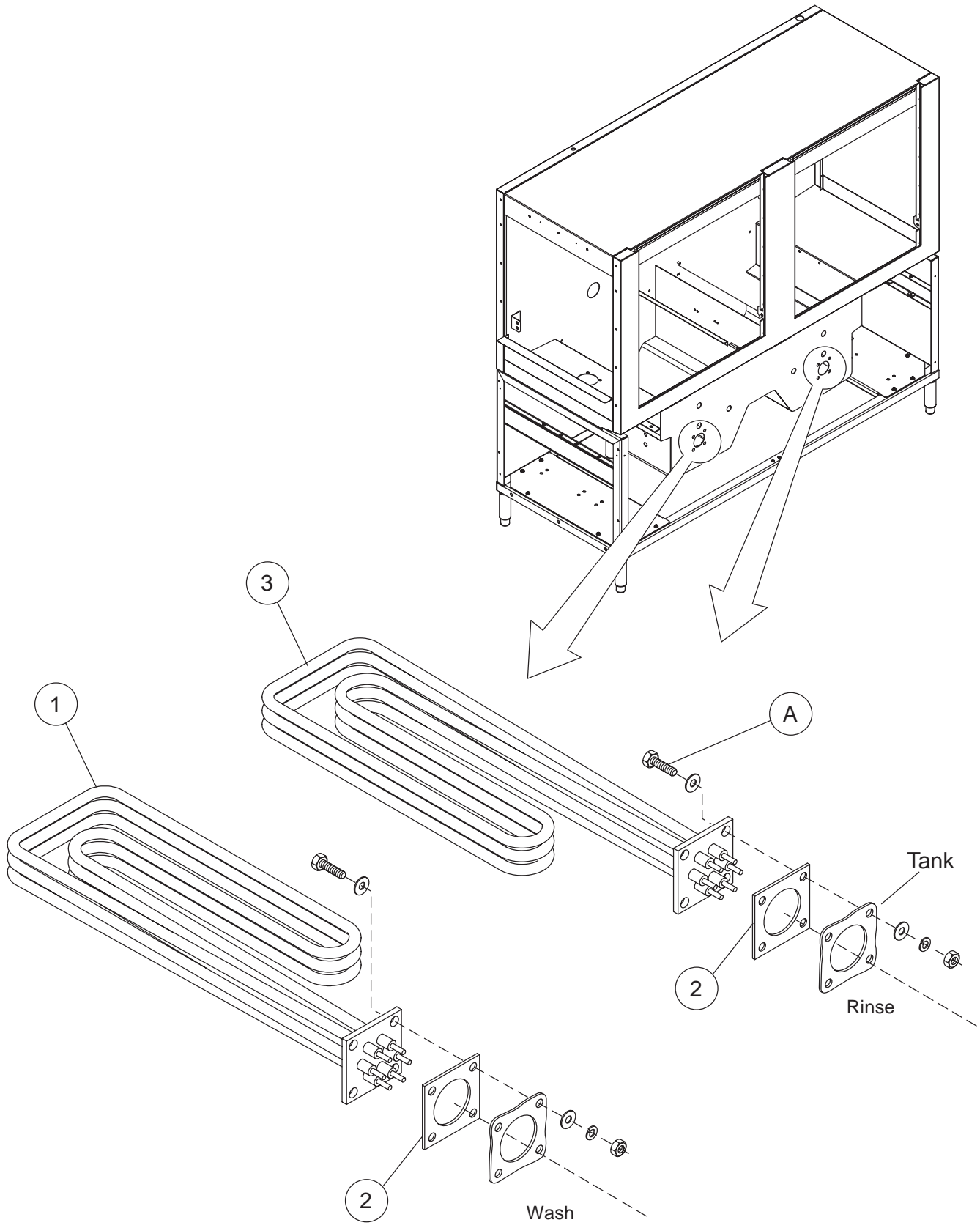

Two Tank Electric Wash and Rinse Tank Heat

Item No.	Part No.	Description	Qty.
1	113516	Heater 15/18KW 200- 220V (Wash)	1
	113517	Heater 15/16.3KW 230- 240V(Wash)	1
	113518	Heater 15/16.3KW 460- 480V (Wash)	1
	113519	Heater 15KW 575V (Wash)	1
2	108345	Gasket 3 x 3 x 1/8" 2" Hole	1
3	113804	Heater 10/12.1 KW 200- 220V (Rinse)	1
	113882	Heater 10/11KW 230- 240V (Rinse)	1
	113883	Heater 10/11KW 460- 480V (Rinse)	1
	113884	Heater 10/11KW 575V (Rinse)	1

A

Element Fasteners (Qty Per Element)

100153	Bolt, 3/18-16 x 1 Hex Head	4
104618	Washer 3/8 x 7/8 x 1/16 SST	8
106407	Washer Lock 3/8 Split	4
100140	Nut Plain 3/8-16	4

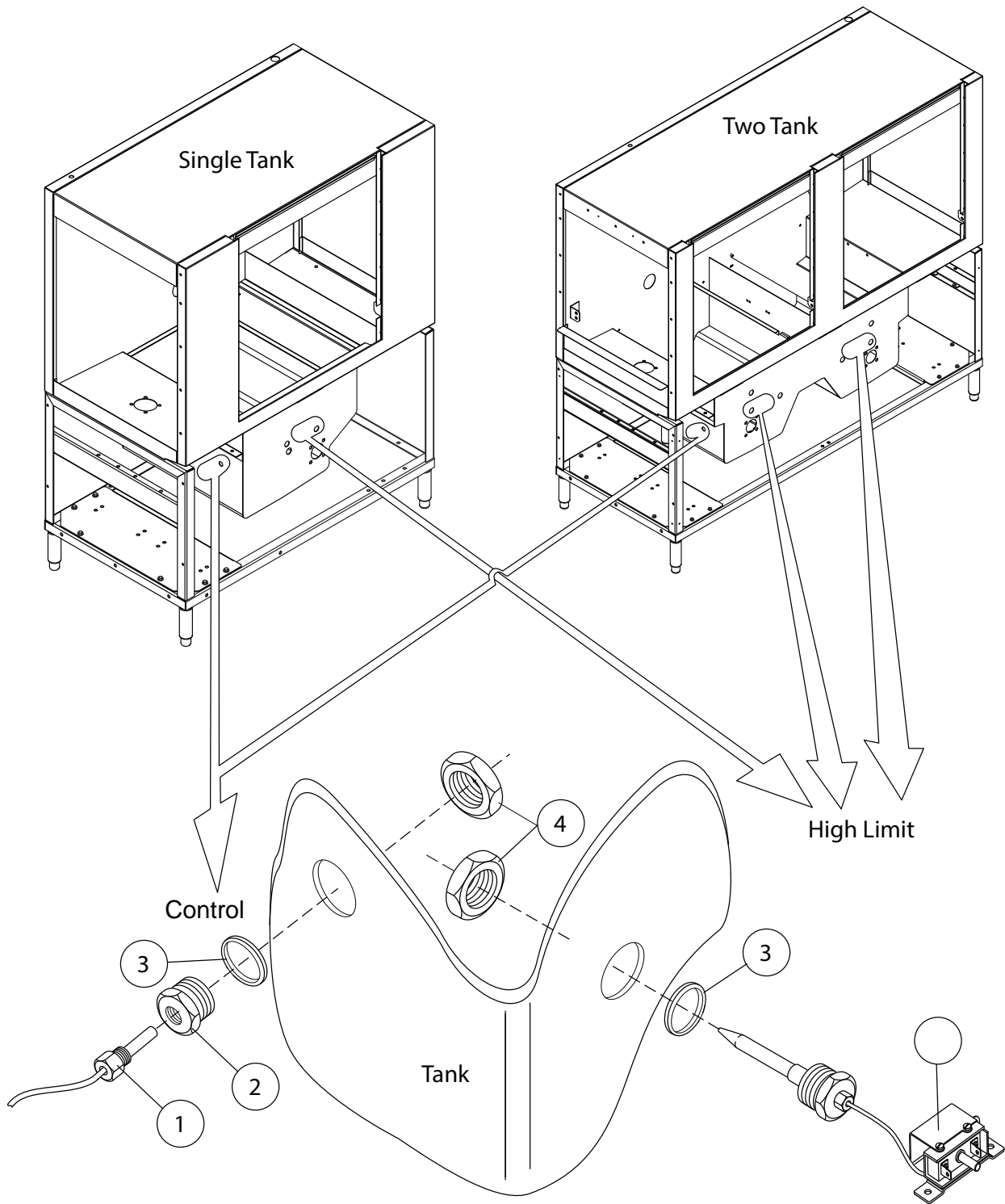

Item No.	Part No.	Description	Qty.
1	114435	Thermistor, 10K Ω , 36" lead	2
2	0512299	Adapter	2
3	115489	O-ring	2
4	100547	Locknut, 1/2" NPT, SST	2
5	110561	Thermostat, Fixed Hi Limit	2

Thermistor Connection Block

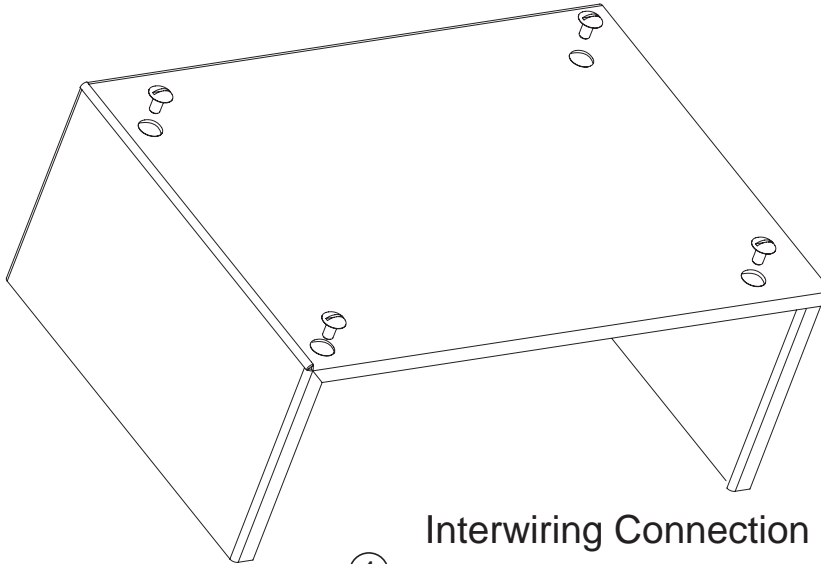
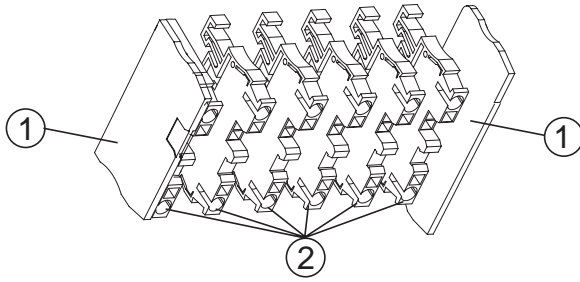

Interwiring Connection Block

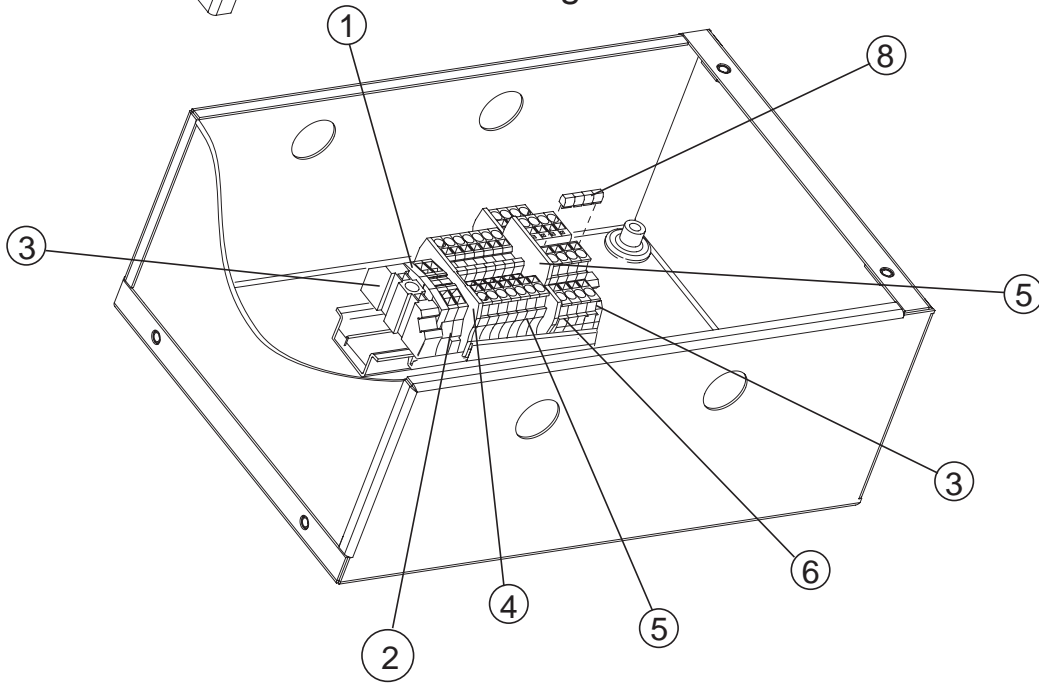

NOTE: Components and quantities vary per machine.

Item No.	Part No.	Description	Qty.
1	114521	End Cover, Single Terminal, D-MZB	A/R
2	114520	Terminal, Single MZB, 1.5 NS35	A/R
3	114519	End Block, E/NS 35 N	2
4	114518	End Cover, Double Terminal STTB 2.5,	A/R
4	114516	End Cover, Single Terminal D-ST 2.5	A/R
5	114515	Terminal, Single, Ground ST 2.5 (Green)	A/R
6	114517	Terminal , Double STTB 2.5	A/R
7	114512	Terminal, Single ST 2.5 (Gray)	A/R
8	114522	Bridge, 10-Pole FPS 10-5 (Cut to Fit)	1

Final Rinse Piping (All Models)

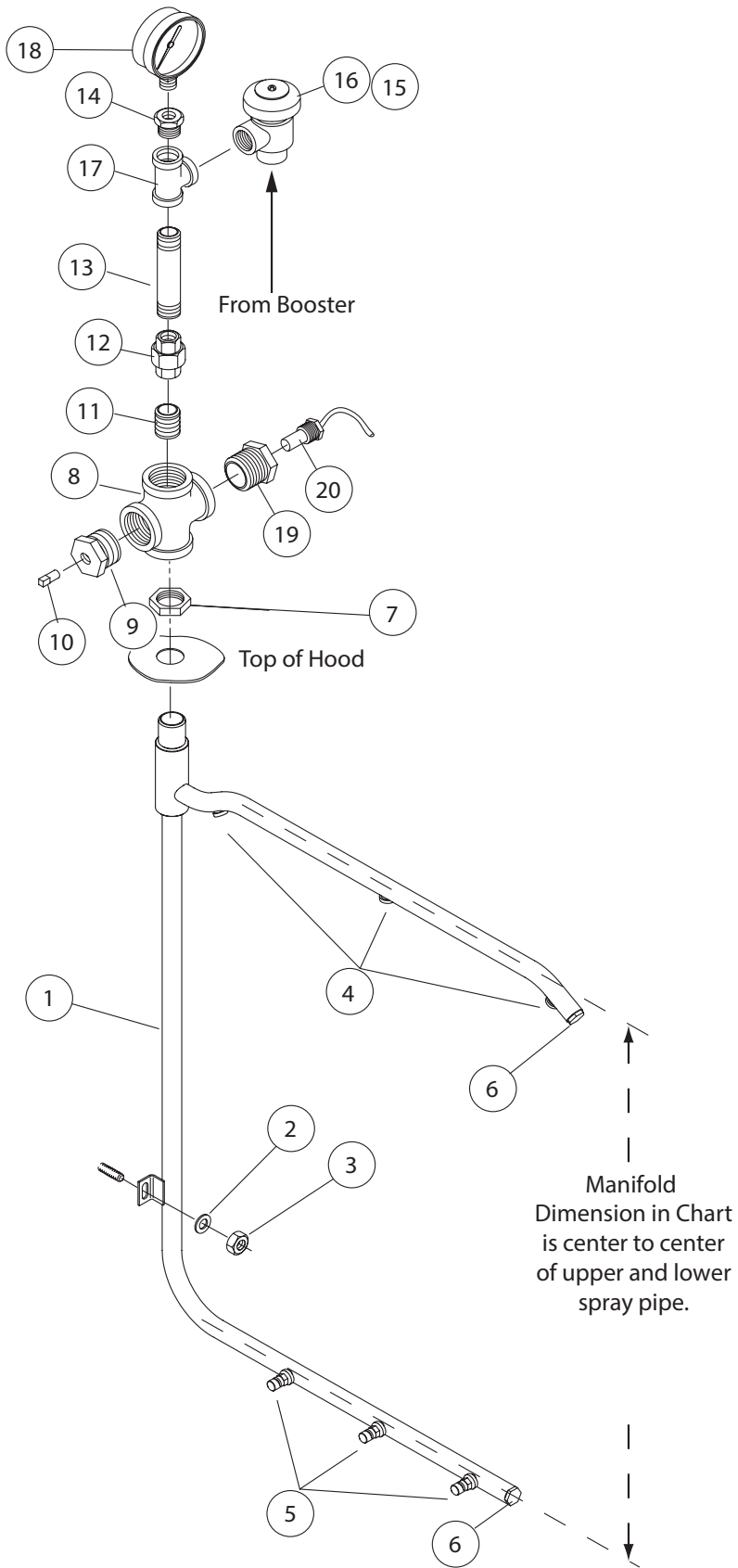

Final Rinse Piping (All Models)

Item No.	Part No.	Description	Qty.
1		See Chart Below for Manifold P/N's	
2	106026	Washer 1/4 x 5/8 x 1/16 SST	1
3	107967	Nut Grip 1/4-20 w/Nylon Insert	1
4		See Chart Below for Upper Nozzle P/N's	3
5		See Chart Below for Lower Nozzle P/N's	3
6	113795	Plug 1 1/16-16 Thread	2
-	109034	Gasket Rinse Pipe (Not Shown)	1
7	100156	Locknut 3/4NPT Brass	1
8	100599	Cross 3/4" NPT Brass	1
9	105976	Bushing Red 3/4" NPT x 1/8" NPT Brass	1
10	101259	Plug 1/8" NPT Brass	1
11	100184	Nipple 3/4"NPT Close Brass	1
12	100571	Union 3/4"NPT Brass	1
13	102470	Nipple 3/4" NPT x 3" Lg Brass	1
14	102388	Bushing, Reducing 1/2"NPT x 1/4"NPT Brass	1
15	104429	Vacuum Breaker 3/4"NPT	1
16	900837	Kit*Repair, 3/4 Vacuum Breaker	A/R
17	102525	Tee, Red 3/4" x 1/2" x 3/4" NPT Brass	1
18	100135	Pressure Gauge 0-60 PSI	1
19	0512299	Adapter	1
20	114435	Thermistor, 10KΩ 36" lead	1

Model	Upper Final Rinse Nozzle	Lower Final Rinse Nozzle	Final Rinse Manifold R-L	Final Rinse Manifold L-R
	P/N	P/N	P/N - Dim.	P/N - Dim.
E44/54	107290	112022	113699 - 25-3/4"	113694 - 25-3/4"
E44/54 HH	107290	112022	114023 - 29-3/4"	114022 - 29-3/4"
E44/54DR	180282	112022	329010 - 25-3/4"	329265 - 25-3/4"
E44/54DR HH	107290	112022	114023 - 29-3/4"	114022 - 29-3/4"
E44/54WS	0508376	112022	113699 - 25-3/4"	113694 - 25-3/4"
E44/54DRWS	0508376	112022	329010 - 25-3/4"	329265 - 25-3/4"
E64/84	107290	112022	113699 - 25-3/4"	113694 - 25-3/4"
E64/E84 HH	107290	112022	114023 - 29-3/4"	114022 - 29-3/4"

Fill Piping (All Models)

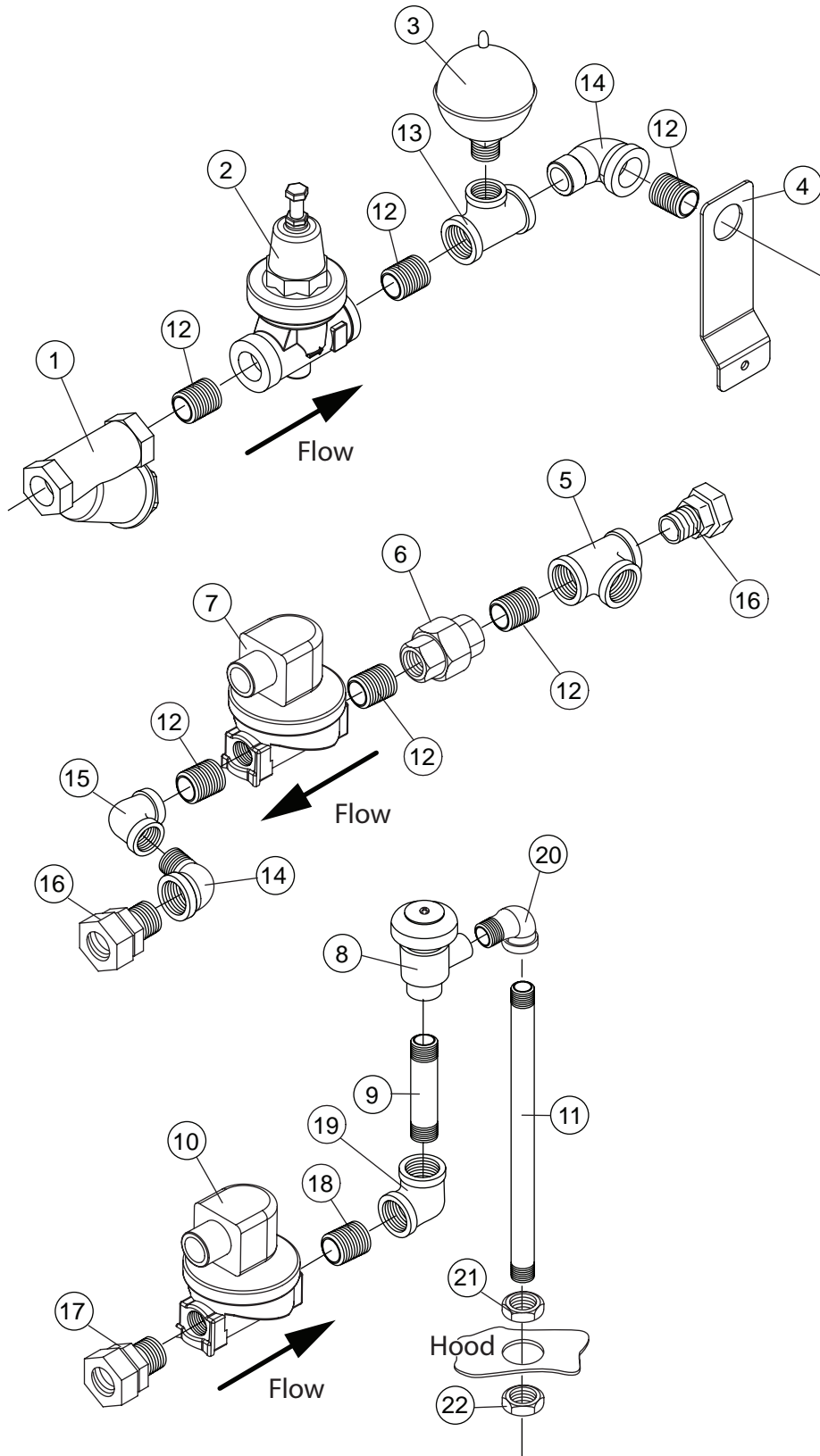

Item No.	Part No.	Description	Qty.
1	110768	Strainer, Line 3/4" NPT Brass Female	1
2	107550	Valve, Pressure Regulating 3/4" NPT Brass	1
3	104681	Arrestor Water Hammer (Optional)	1
4	311694	Bracket, Piping Support	1
5	102521	Tee, 3/4" NPT Brass	1
6	100571	Union, 3/4" NPT Brass	1
7	111437	Valve, Solenoid 3/4" NPT HW 120VAC coil	1
–	114839	Kit, Repair 3/4" Diaphragm	A/R
–	111472	Coil, Solenoid 3/4" 120VAC	A/R
8	100500	Breaker, Vacuum 1/2 " NPT	1
–	900836	Kit, Repair Vacuum Breaker	A/R
9	100206	Nipple, 1/2" NPT x 2-1/2" Lg. Brass	1
10	109886	Valve, Solenoid 1/2" NPT HW 120VAC Coil	1
–	109902	Kit, Repair, 1/2" Diaphragm	A/R
–	108516	Coil, Solenoid Valve 1/2" 120VAC	A/R
11	101397	Nipple, RTOE, 1/2" NPT x &" Lg. Brass	1
12	100184	Nipple, Close 3/4" NPT Brass	6
13	102526	Tee, 3/4" NPT x 3/4" NPT x 1/2" NPT Brass	1
14	102444	Elbow, Street, 3/4" NPT x 90° Brass	2
15	102442	Elbow, 3/4" NPT x 90° Brass	1
16	109879	Fitting Comp. 7/8" O.D. x 3/4" NPT Brass	2
17	114384	Fitting Comp. 7/8" O.D. x 1/2" NPT Brass	1
18	100209	Nipple, Close 1/2" NPT	1
19	102435	Elbow, 1/2" NPT x 90° Brass	1
20	102438	Elbow, Street, 1/2" NPT x 90° Brass	1
21	100709	Locknut, 1/2" NPT Brass	1
22	201029	Locknut, 1/2" NPT Nickle-plate	1

Prewash Cold Water Tempering (CWT) Piping

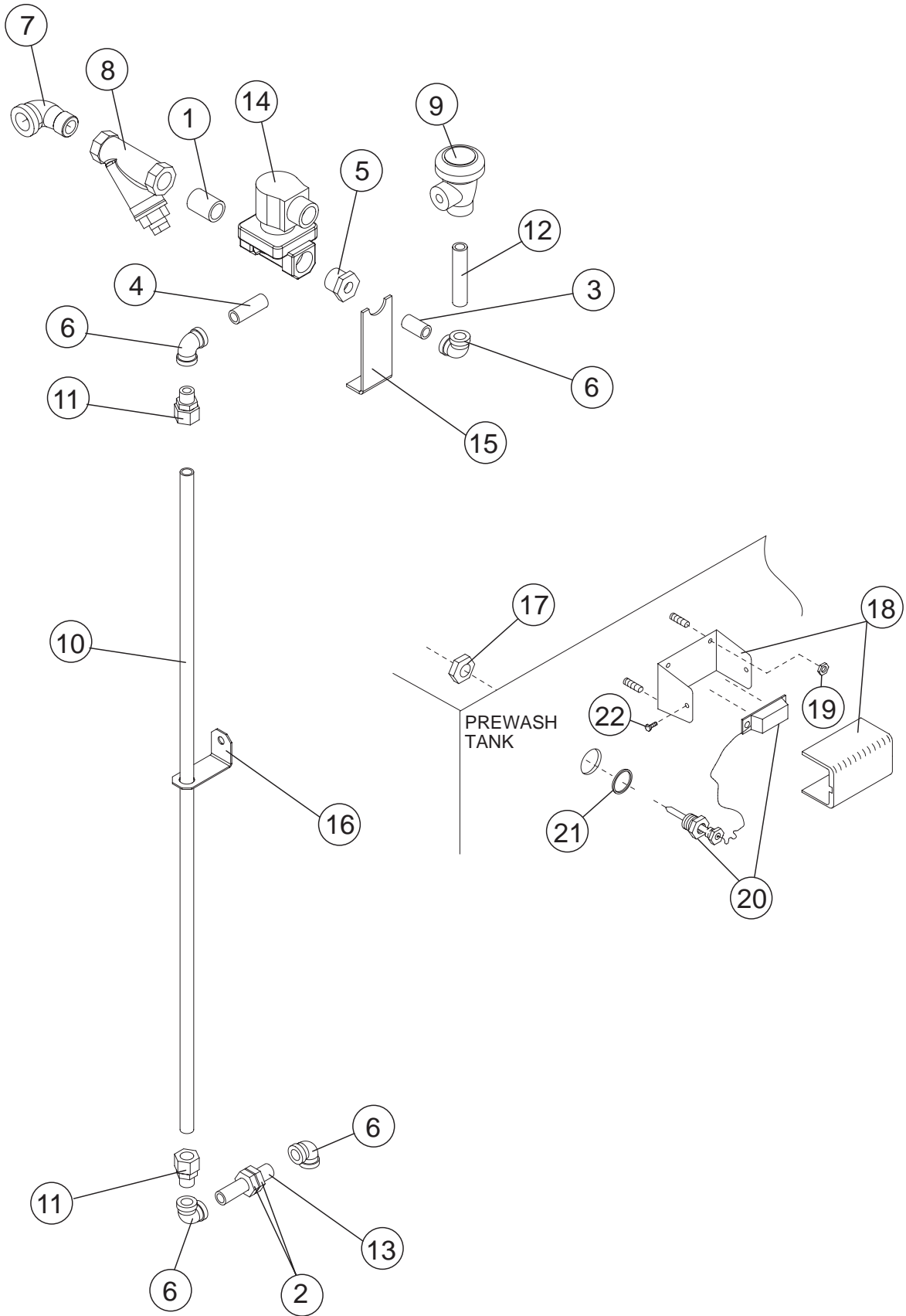

Prewash Cold Water Tempering (CWT) Piping

Item No.	Part No.	Description	Qty.
1	100209	Nipple, 1/2" NPT Close, Brass	1
2	100573	Locknut, 1/2" NPT Brass	2
3	100947	Nipple, 1/4" NPT Close Brass	1
4	101262	Nipple, 1/4" NPT x 1-1/2" Lg. Brass	1
5	102388	Bushing Reducing 1/2" NPT x 1/4" NPT Brass	1
6	102422	Elbow, 1/4" NPT 90° Brass	4
7	102438	Elbow, Street 1/2" NPT 90° Brass	1
8	104421	Strainer, Line 1/2" NPT Bronze	1
9	107069	Breaker, Vacuum 1/4" NPT Brass	1
–	900836	Kit, Repair Vacuum Breaker	A/R
10	107315	Tubing, 3/8" Type L Copper	1
11	109909	Fitting Comp. 1/2" O.D. x 1/4" MPT Brass	2
12	110134	Nipple, 1/4" NPT x 2-1/2" Lg. Brass	1
13	112109	Nipple, RTOE 1/4" NPT x 2-1/2" Lg. Brass	1
14	109886	Valve, Solenoid 1/2" NPT 120VAC	1
–	113392	Kit, Repair Valve Diaphragm 1/2"	A/R
–	113357	Coil, Solenoid 1/2" 120VAC	A/R
15	319549	Bracket, Cold Water Thermostat Piping	1
16	328539	Bracket, Piping Support	1
17	100547	Locknut, 1/2" NPT SST	1
18	900982	Box and Cover, Thermostat	1
19	107966	Gripnut, 10-32 w/nylon insert	2
20	109069	Thermostat, Control w/capillary	1
21	115489	O-ring	1
22	106460	Screw, 6-32 x 1/4" Truss Hd.	2

Single and Two Tank Electric Booster Assembly - 40°F/70°F Rise

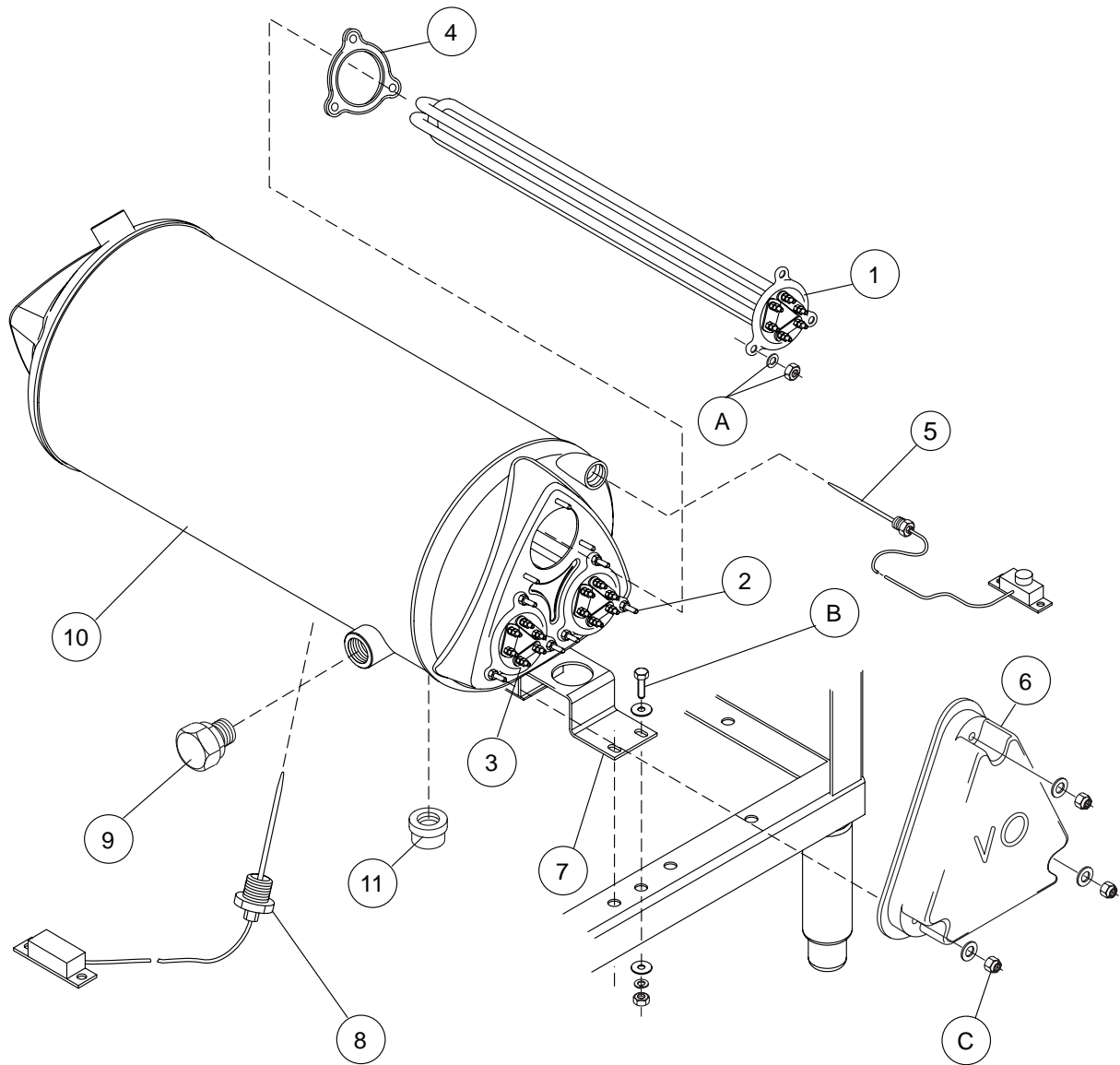

ATTENTION:

Install the highest Kw rated element in the top and the lowest rated element in the corner closest to Item 9 in the illustration above. Item 9 may be located on the opposite side of the booster.

Single and Two Tank Electric Booster Assembly - 40°F/70°F Rise

Item No.	Part No.	Description	Qty.
1, 2, 3		Refer to the booster diagrams on the next four pages.	
4	109985	Seal, Electric Heater Flange	3
5	110561	Thermostat w/Capillary, Fixed High Limit 240°F	1
6	108576	Cover, Booster No Cutout	1
7	328254	Bracket, Front Booster	1
8	110561	Thermostat w/ Capillary, Control	1
9	102505	Plug 3/4" NPT Brass	1
10	414331	Tank Booster	1
11	100113	Cap, 3/4" NPT SST	1
12	109458	Plate, Blockoff (Not shown)	A/R

A Element Fasteners (Qty per Element)

100003	Nut Plain 1/4-20	9
106482	Washer Lock 1/4 Split	9

B Booster Tank Fasteners

100739	Bolt 5/16-18 x 3/4 Hex Head SST	4
106013	Washer Lock 5/16 Split	4
100142	Nut, Grip 5/16 w/Nylon Insert	4

C Element Cover Fasteners

100141	Nut Grip 1/4-20 w/Nylon insert	3
106026	Washer Flat 1/4"	3

Single Tank Electric Booster Heaters- 40°F/70°F Rise

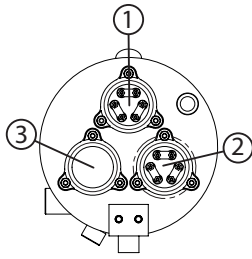

12KW 208-240V/60/3 40° Rise

Item No.	Part No.	Description	Qty.
1	107909	6/8 KW Heater	1
2	107909	6/8 KW Heater	1
3	109458	Blockoff Plate	1

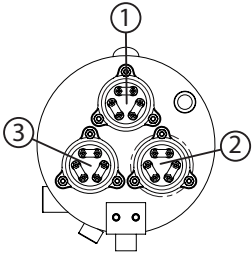

22KW 208-240V/60/3 70° Rise

Item No.	Part No.	Description	Qty.
1	112232	10 KW Heater	1
2	107909	6/8 KW Heater	1
3	107909	6/8 KW Heater	1

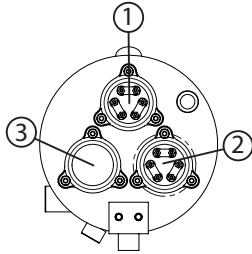

12KW 230-240V/60/3 40° Rise

Item No.	Part No.	Description	Qty.
1	114030	6 KW Heater	1
2	114030	6 KW Heater	1
3	109458	Blockoff Plate	1

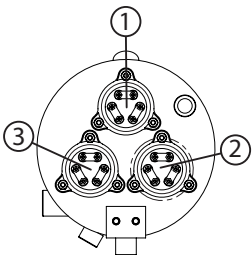

22KW 230-240V/60/3 70° Rise

Item No.	Part No.	Description	Qty.
1	111233	7.5/10 KW Heater	1
2	114030	6 KW Heater	1
3	114030	6 KW Heater	1

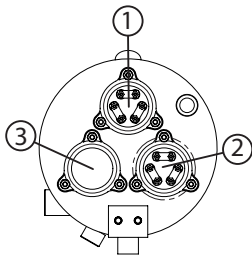

12KW 460-480V/60/3 40° Rise

Item No.	Part No.	Description	Qty.
1	114031	6 KW Heater	1
2	114031	6 KW Heater	1
3	109458	Blockoff Plate	1

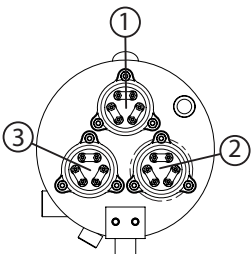

22KW 460-480V/60/3 70° Rise

Item No.	Part No.	Description	Qty.
1	111234	10 KW Heater	1
2	114031	6 KW Heater	1
3	114031	6 KW Heater	1

Single Tank Electric Booster Heaters- 40°F/70°F Rise

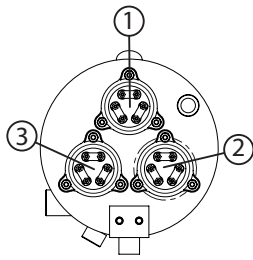

12KW 575V/60/3 40° Rise

Item No.	Part No.	Description	Qty.
1	114032	6 KW Heater	1
2	114032	6 KW Heater	1
3	109458	Blockoff Plate	1

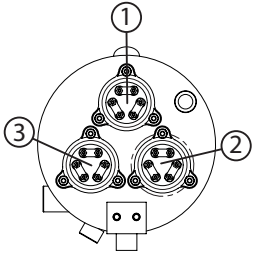

22KW 575V/60/3 70° Rise

Item No.	Part No.	Description	Qty.
1	111383	10 KW Heater	1
2	114032	6 KW Heater	1
3	114032	6 KW Heater	1

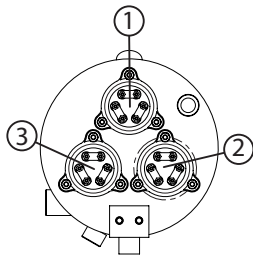

30KW 200-220V/60/3 Heat Recovery

Item No.	Part No.	Description	Qty.
1	111232	10 KW Heater	1
2	111232	10 KW Heater	1
3	111232	10 KW Heater	1

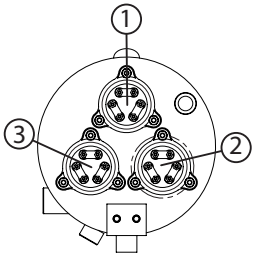

30KW 230-240V/60/3 Heat Recovery

Item No.	Part No.	Description	Qty.
1	111233	7.5/10 KW Heater	1
2	111233	7.5/10 KW Heater	1
3	111233	7.5/10 KW Heater	1

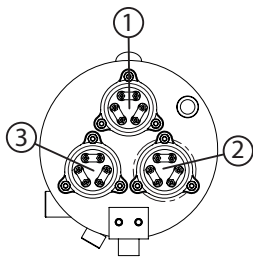

30KW 460-480V/60/3 Heat Recovery

Item No.	Part No.	Description	Qty.
1	111234	10 KW Heater	1
2	111234	10 KW Heater	1
3	111234	10 KW Heater	1

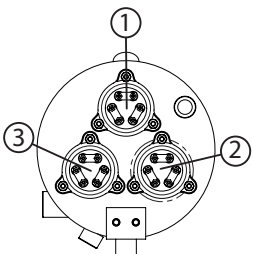

30KW 575V/60/3 Heat Recovery

Item No.	Part No.	Description	Qty.
1	111383	10 KW Heater	1
2	111383	10 KW Heater	1
3	111383	10 KW Heater	1

Two Tank Electric Booster Heaters- 40°F/70°F Rise

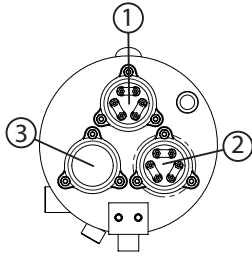

15KW 208-240V/60/3 40° Rise

Item No.	Part No.	Description	Qty.
1	111235	5/6.6 KW Heater	1
2	111235	5/6.6 KW Heater	1
3	111235	5/6.6 KW Heater	1

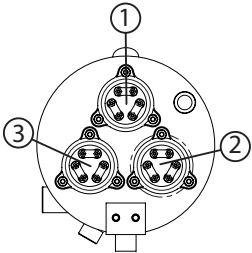

24KW 208-240V/60/3 70° Rise

Item No.	Part No.	Description	Qty.
1	112059	12 KW Heater	1
2	107909	6/8 KW Heater	1
3	107909	6/8 KW Heater	1

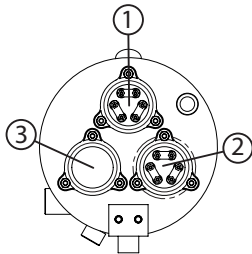

15KW 230-240V/60/3 40° Rise

Item No.	Part No.	Description	Qty.
1	111236	5 KW Heater	1
2	111236	5 KW Heater	1
3	111236	5 KW Heater	1

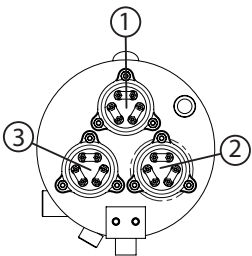

24KW 230-240V/60/3 70° Rise

Item No.	Part No.	Description	Qty.
1	111334	9/12 KW Heater	1
2	111334	9/12 KW Heater	1
3	111334	9/12 KW Heater	1

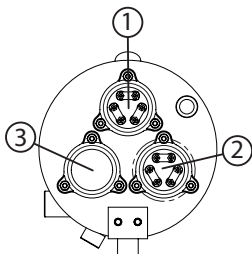

15KW 460-480V/60/3 40° Rise

Item No.	Part No.	Description	Qty.
1	111237	5 KW Heater	1
2	111237	5 KW Heater	1
3	111237	5 KW Heater	1

Two Tank Electric Booster Heaters- 40°F/70°F Rise

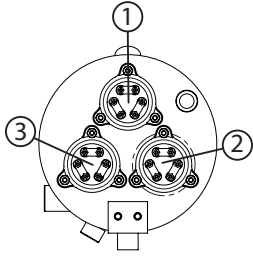

24KW 460-480V/60/3 70° Rise

Item No.	Part No.	Description	Qty.
1	112060	12 KW Heater	1
2	112060	12 KW Heater	1
3	112060	12 KW Heater	1

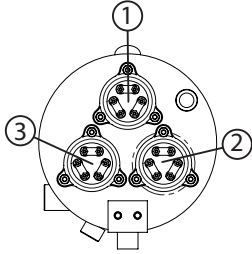

15KW 575V/60/3 40° Rise

Item No.	Part No.	Description	Qty.
1	111384	5 KW Heater	1
2	111384	5 KW Heater	1
3	111384	5 KW Heater	1

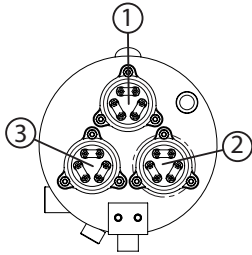

24KW 575V/60/3 70° Rise

Item No.	Part No.	Description	Qty.
1	112061	12 KW Heater	1
2	114032	6 KW Heater	1
3	114032	6 KW Heater	1

NOTE:

Two tank machines do not have a 30KW heat recovery booster tank.

Two Tank & Heat Recovery Electric Booster Cabinet- 40°F/70°F Rise

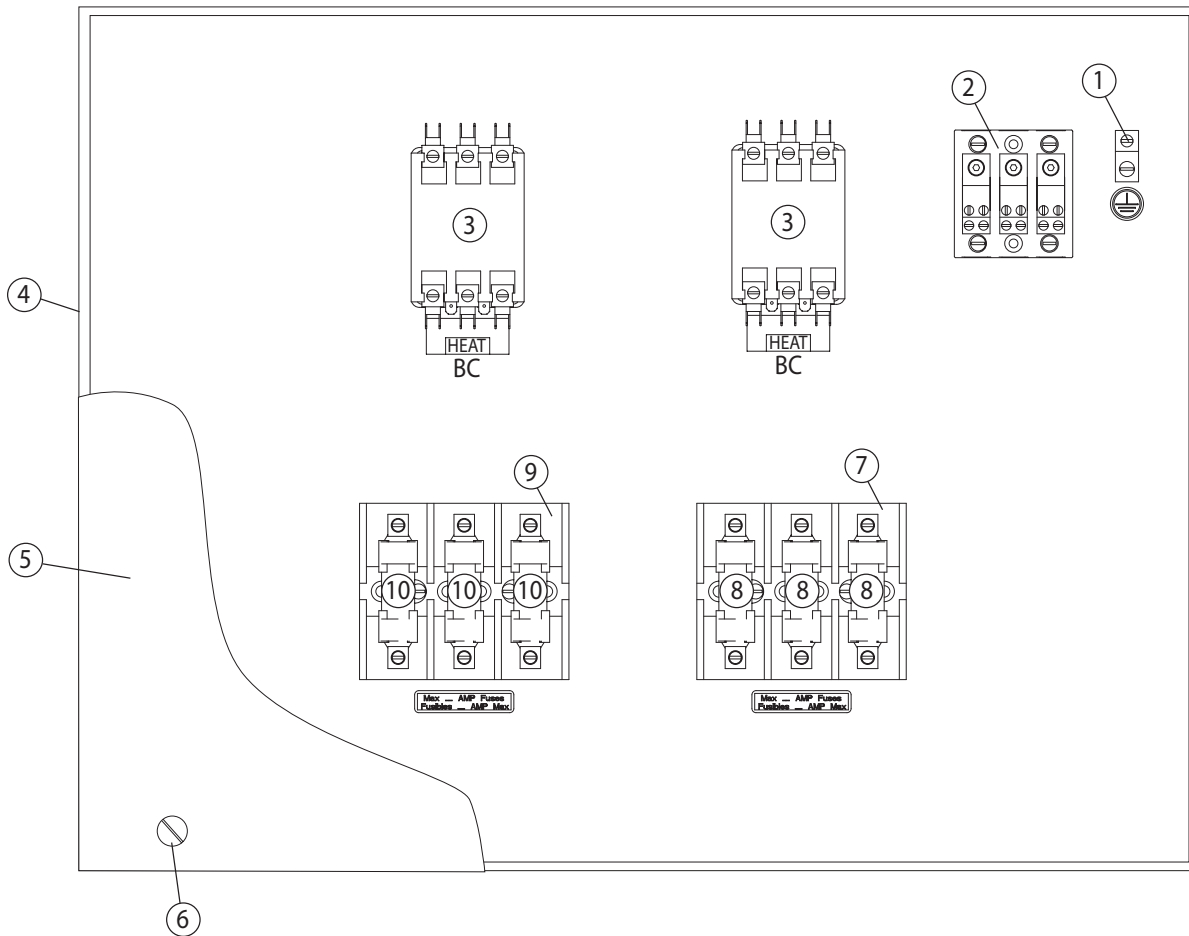

COMMON ELECTRICAL PARTS (Not Voltage Specific)

1	103310	Lug, Ground	1
2	111833	Block, Input Terminal 175A 3-Pole (Not Shown)	1
3	111827	Contactors Heat 60 FLA	2
4	328421	Cabinet, Booster Control	1
5	328525	Cover, Cabinet, Booster Control	1
6	100073	Screw, 1/4-20 x 1/2" Truss Head	2

200-220V/60/3 (15KW Booster)

1	180171	Block, Fuse 600V 60A 3P J Type	1
1	180174	Fuse, J 45A 600V	3

230-240V/60/3 (15KW Booster)

1	180171	Block, Fuse 600V 60A 3P J Type	1
1	180173	Fuse, J 40A 600V	3

460-480V/60/3 (15KW Booster)

1	111135	Block, Fuse 600V 30A 3P J Type	1
1	112062	Fuse, J 20A 600V	3

Two Tank & Heat Recovery Electric Booster Cabinet - 40°F/70°F Rise

Item No.	Part No.	Description	Qty.
<u>460-480V/60/3 (15KW Booster)</u>			
1	111135	Block, Fuse 600V 30A 3P J Type	1
1	112062	Fuse, J 20A 600V	3
<u>575/60/3 (15KW Booster)</u>			
1	111135	Block, Fuse 600V 30A 3P J Type	1
1	111682	Fuse, J 15A 600V	3
<u>200-220V/60/3 (24KW Booster)</u>			
1	108424	Block, Fuse 600V 100A 3P T Type	1
2	180059	Fuse, T 80A 250V	3
<u>230-240V/60/3 (24KW Booster)</u>			
1	108424	Block, Fuse 600V 100A 3P T Type	1
2	180060	Fuse, T 70A 250V	3
<u>460-480V/60/3 (24KW Booster)</u>			
1	180171	Block, Fuse 600V 60A 3P J Type	1
2	180072	Fuse, J 35A 250V	3
<u>575/60/3 (24KW Booster)</u>			
1	111135	Block, Fuse 600V 30A 3P J Type	1
2	180172	Fuse, J 35A 250V	3
<u>200-220V/60/3 (30KW Heat Recovery Booster)</u>			
1	111135	Block, Fuse 600V 30A 3P J Type	1
2	180172	Fuse, J 35A 250V	3
<u>230-240V/60/3 (30KW Heat Recovery Booster)</u>			
1	111135	Block, Fuse 600V 30A 3P J Type	1
2	180172	Fuse, J 35A 250V	3
<u>460-480V/60/3 (30KW Heat Recovery Booster)</u>			
1	111135	Block, Fuse 600V 30A 3P J Type	1
2	180172	Fuse, J 35A 250V	3
<u>575V/60/3 (30KW Heat Recovery Booster)</u>			
1	111135	Block, Fuse 600V 30A 3P J Type	1
2	180172	Fuse, J 35A 250V	3

Two Tank Steam Heat with K2 Steam Booster

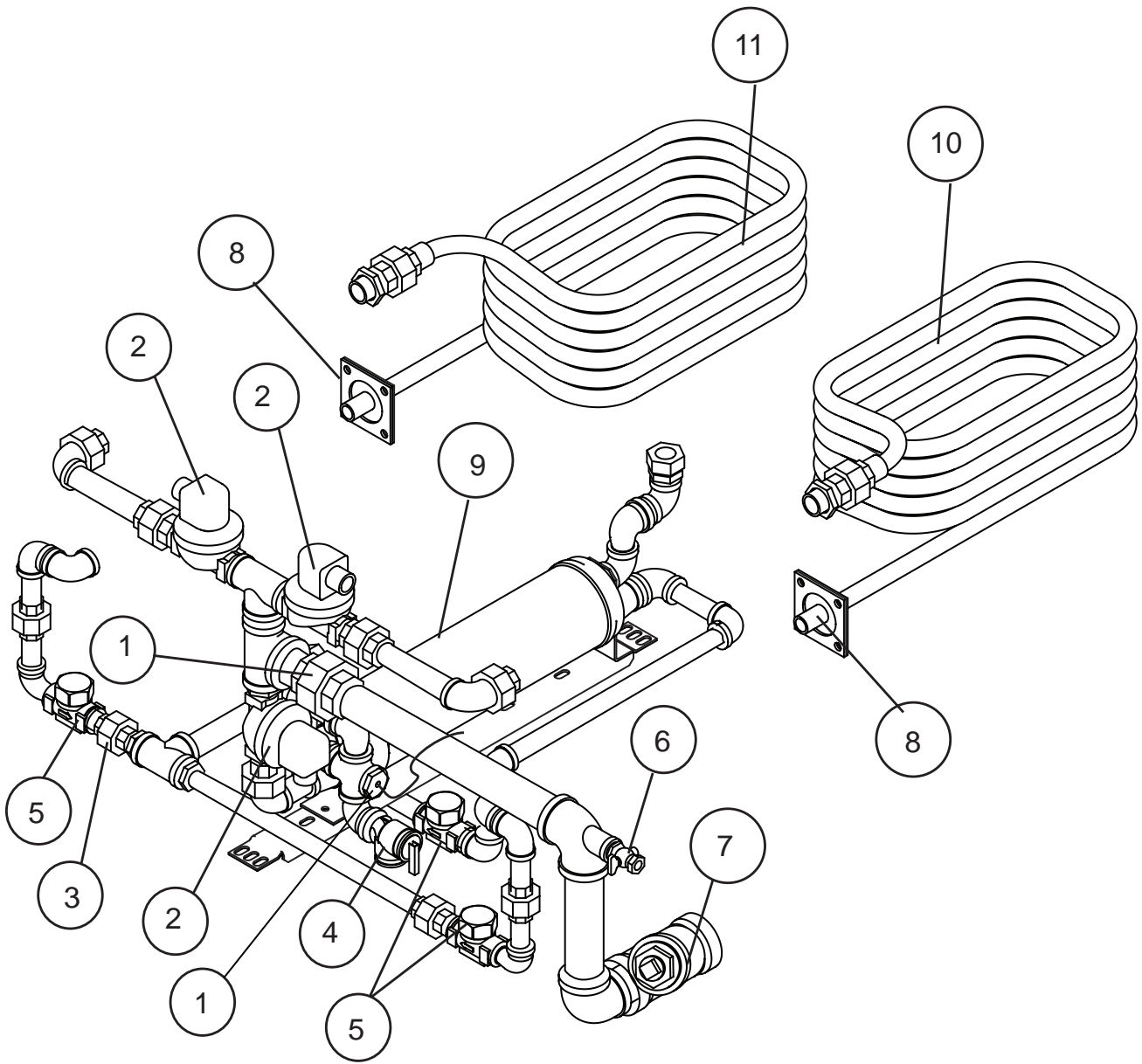

Two Tank Steam Heat with K2 Steam Booster

Item No.	Part No.	Description	Qty.
1	109069	Thermostat, Control	1
2	109887	Valve, 3/4" Solenoid 120VAC	3
—	109903	Kit, Repair Solenoid Valve	A/R
—	108516	Coil, Replacement 120VAC	A/R
3	105782	Nipple, Close 1/2 NPT BI	4
4	104649	Relief, Valve	1
5	111380	Trap, Steam 1/2"	3
6	100123	Cock, Gauge 1/4"	1
7	100263	Strainer, Line 1-1/4" BI	1
8	108345	Gasket	2
9	110189	Booster, K2 Spirec	1
10	327907	Coil, Steam R-L	1
11	327908	Coil, Steam L-R	1

Single Tank Steam Heat

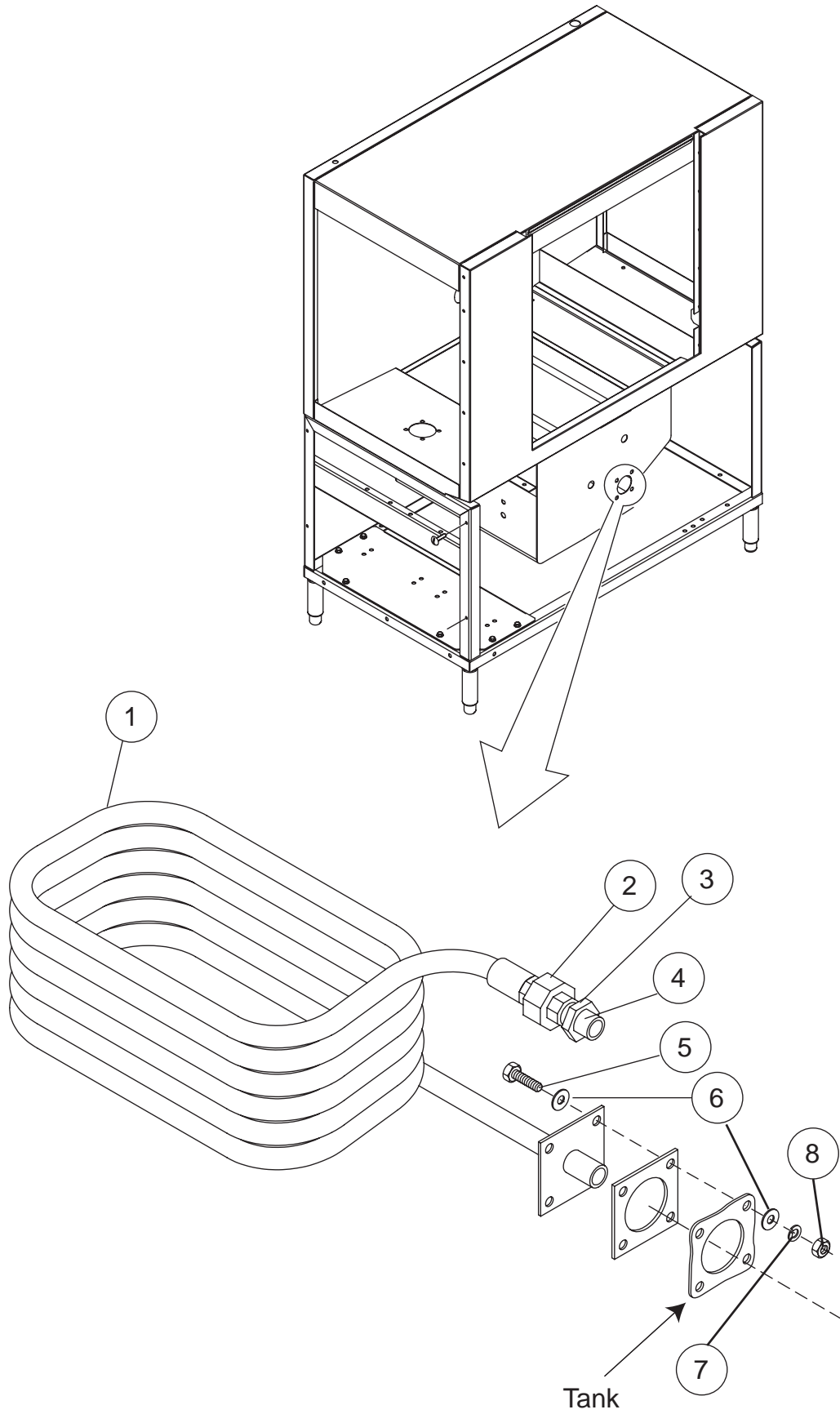

Item No.	Part No.	Description	Qty.
1	327908	Coil, Steam RH (Shown)	1
1	327907	Coil, Steam LH	1
2	102554	Union 3/4 SST	1
3	100548	Locknut, 3/4NPT SST	1
4	113918	Nipple, RTOE 3/4 x 1-3/4	1
5	100740	Bolt 5/16-18 x 1 Hex Head	4
6	102376	Washer 5/16 X 3/4 x 1/16	8
7	108345	Gasket 3 x 3 1/8" 2IN Hole	1
8	106013	Washer Lock 5/16 Split	4
9	100154	Nut Plain 5/16-18	4

NOT SHOWN

–	109887	Valve, 3/4" Solenoid 120VAC	3
–	109903	Kit, Repair Solenoid Valve	A/R
–	108516	Coil, Replacement 120VAC	A/R
–	104649	Relief, Valve	1
–	111380	Trap, Steam 1/2"	3
–	100123	Cock, Gauge 1/4"	1
–	100263	Strainer, Line 1-1/4" Bl	1

Two Tank Steam Heat

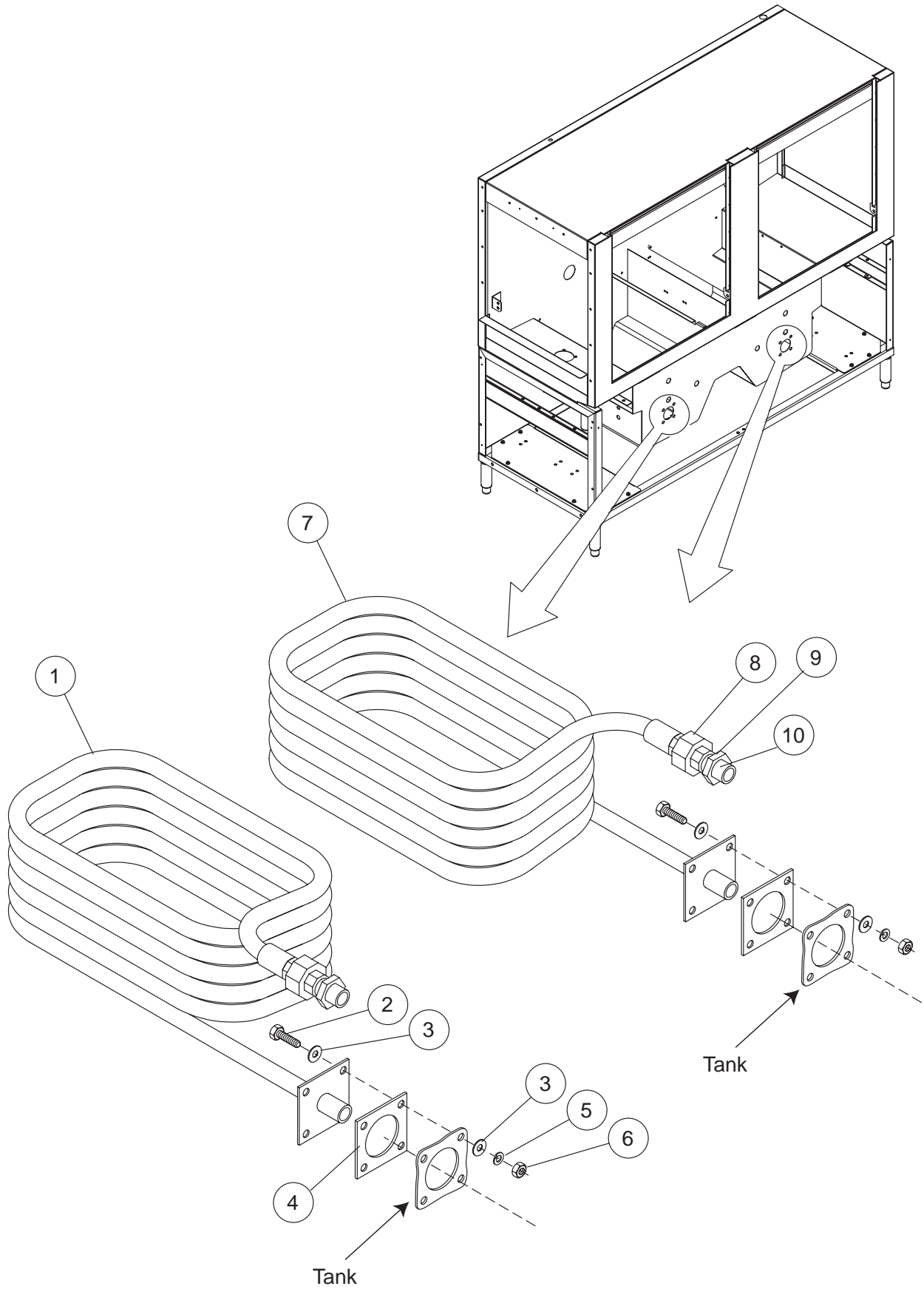

Item No.	Part No.	Description	Qty.
1	327907	Coil, Steam LH	1
2	100740	Bolt 5/16-18 x 1 Hex Head	8
3	102376	Washer 5/16 X 3/4 x 1/16	16
4	108345	Gasket 3 x 3 1/8" 2IN Hole	2
5	106013	Washer Lock 5/16 Split	8
6	100154	Nut Plain 5/16-18	8
7	327908	Coil, Steam RH	1
8	102554	Union 3/4 SST	2
9	100548	Locknut, 3/4NPT SST	2
10	113918	Nipple, Rtoe 3/4 x 1-3/4	2

22" ,26" and 36" Prewash Drain Assemblies

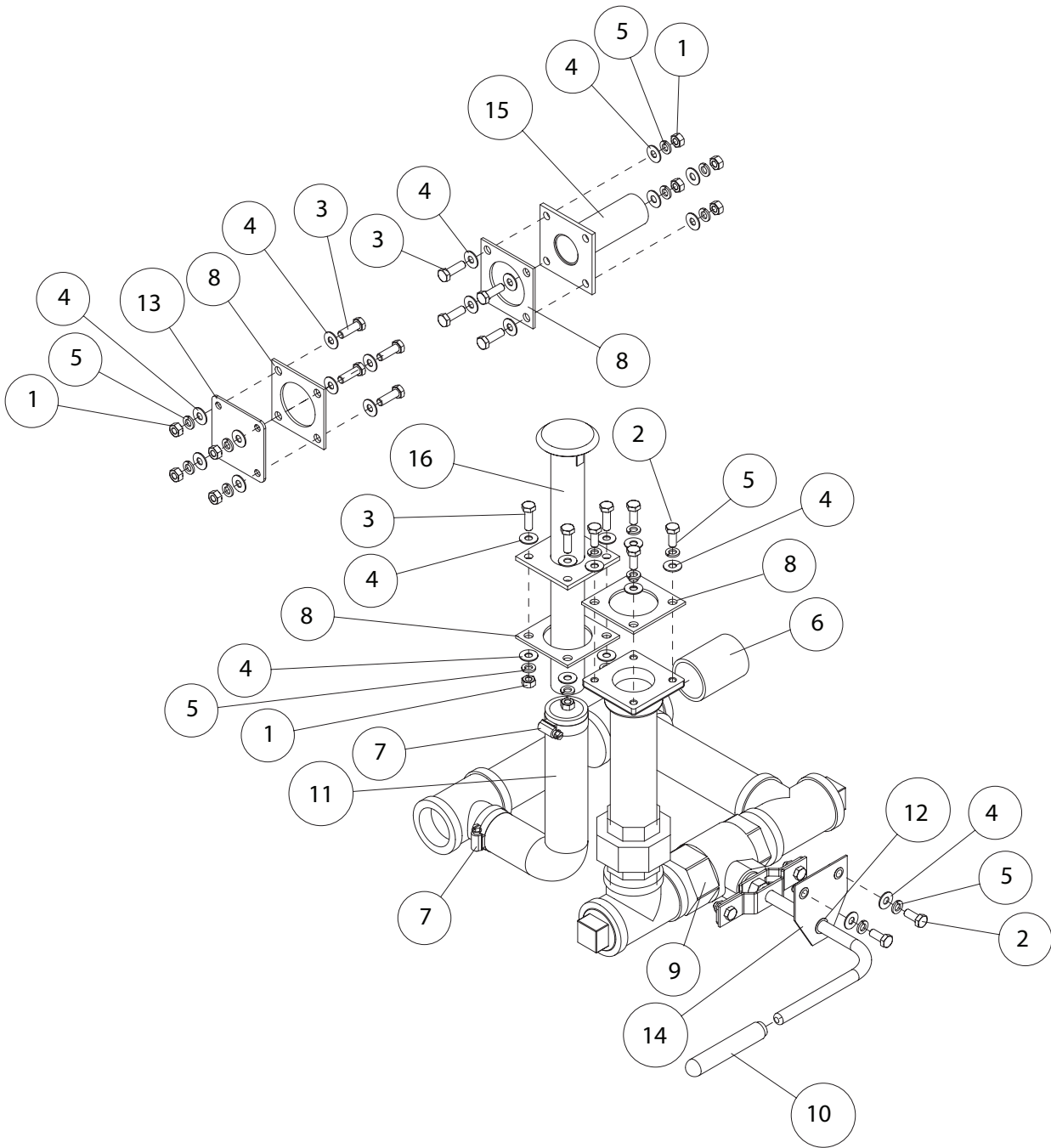

L-R Direction Shown

22", 26" and 36" Prewash Drain Assemblies

Item No.	Part No.	Description	Qty.
1	100154	Hex, Plain Nut, 5/16-18 SST	12
2	100739	Bolt, Hex Hd. 5/16-18 x 3/4" SST	6
3	100740	Bolt, Hex Hd. 5/16-18 x 1" SST	12
4	102376	Washer, Flat 5/16 SST	30
5	106013	Washer, Lock 5/16 SST	18
6	106687	Nipple, TOE 1-1/2" NPT x 2-1/2" Lg. Galv. (22" PW)	1
—	115327	Nipple, TOE 1-1/2" NPT x 4-1/2" Lg. Galv. (26" PW)	1
—	203005	Nipple, TOE 1-1/2" NPT x 15-1/2" Lg. Galv. (36" PW)	1
7	107340	Clamp, Hose M28 Gear-type	2
8	108345	Gasket, Heater/Standpipe	4
9	602041	Drain, Sub-assy	1
10	114185	Grip, Drain Handle	1
11	114472	Hose, Overflow	1
12	114817	Bearing, Sleeve 1/2" Dia. Rod, Nylon	1
13	314388-1	Flange, Blockoff	1
14	334715	Bracket, Ball Valve Handle Support	1
15	334719	Stub, Crossflow Weldment	1
16	334758	Overflow, Prewash Weldment	1

E44DR with & without Prewash Drain Assembly

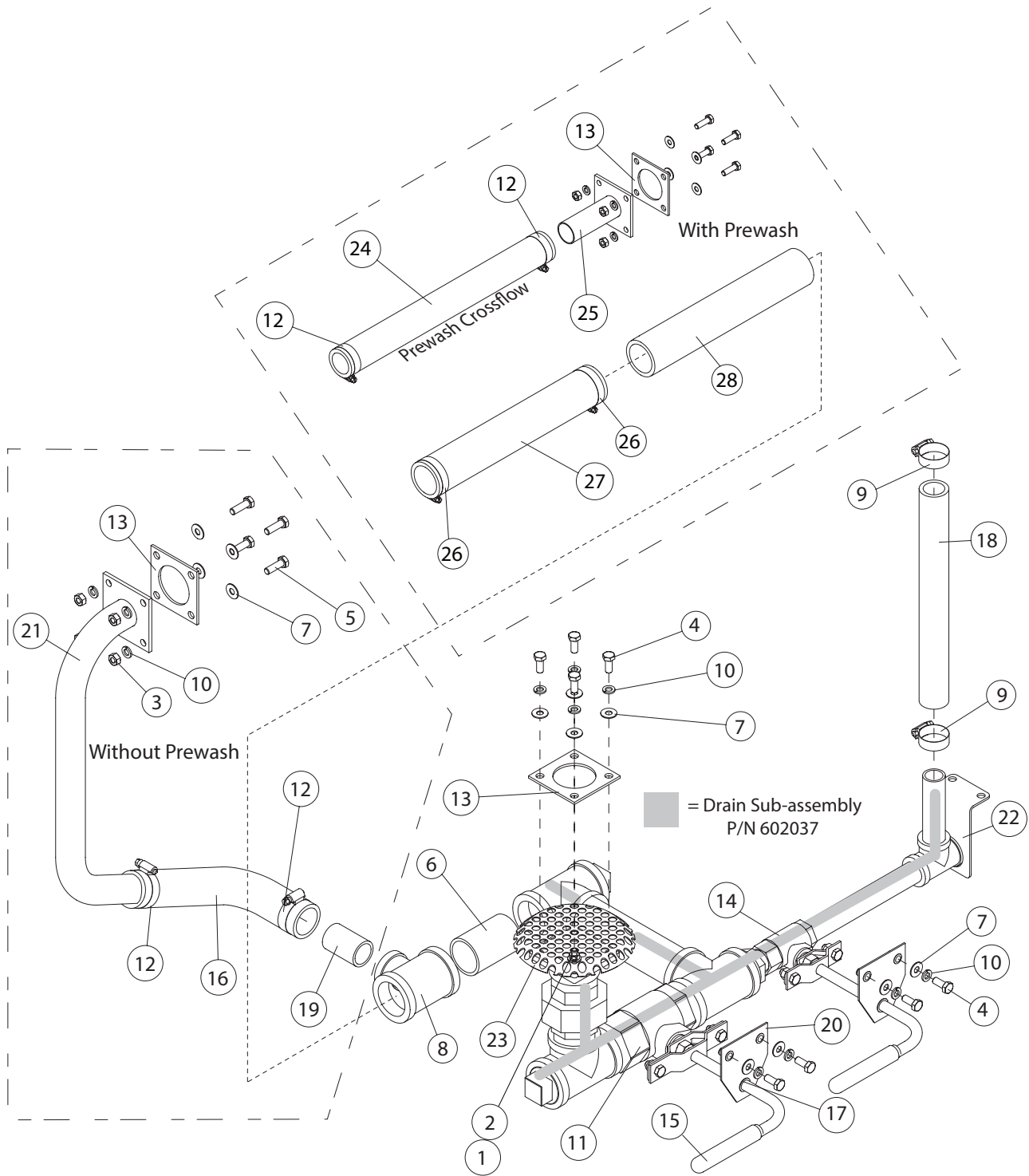

L-R Direction Shown

E44DR with & without Prewash Drain Assembly

Item No.	Part No.	Description	Qty.
1	100003	Hex, Plain Nut, 1/4-20 SST	1
2	106026	Washer, Flat 1/4" SST	1
3	100154	Hex, Plain Nut, 5/16-18 SST	4
4	100739	Bolt, Hex Hd. 5/16-18 x 3/4" SST	8
5	100740	Bolt, Hex Hd. 5/16-18 x 1" SST	4
6	101835	Nipple, 1-1/2" NPT x 2-3/4" Lg. Galv.	1
7	102376	Washer, Flat 5/16 SST	12
8	102543	Tee, 1-1/2" NPT x 1-1/2" NPT x 1" NPT Galv.	1
9	105993	Clamp, Hose M20 Gear-type	2
10	106013	Washer, Lock 5/16 SST	12
11	115117	Valve, Ball 1-1/2" NPT with T-handle	1
12	107340	Clamp, Hose M28 Gear-type	2
13	108345	Gasket, Heater/Standpipe	2
14	115223	Valve, Ball 3/4" NPT with T-handle	1
15	114185	Grip, Drain Handle	2
16	114472	Hose, Overflow	1
17	114817	Bearing, Sleeve 1/2" Dia. Rod, Nylon	2
18	115230	Hose, DR Drain	1
19	204383	Nipple, TOE 1" NPT x 2" Lg. Galv.	1
20	334715	Bracket, Ball Valve Handle Support	2
21	334718	Overflow Weldment	1
22	334902	Bracket, DR Drain Support	1
23	335386	Strainer, Drain 6" Dia.	1
24	207216	Hose, 1-3/8" ID x 17" Lg.	1
25	334719	Stub, Crossflow Weldment	1
26	104165	Clamp, Hose M40 Gear-type	2
27	202240	Hose, 1-7/8" ID x 16-1/2" Lg.	1
28	203005	Nipple, TOE, 1-1/2" NPT x 15-1/2" Lg. Galv.	1

E54DR with & without Prewash Drain Assembly

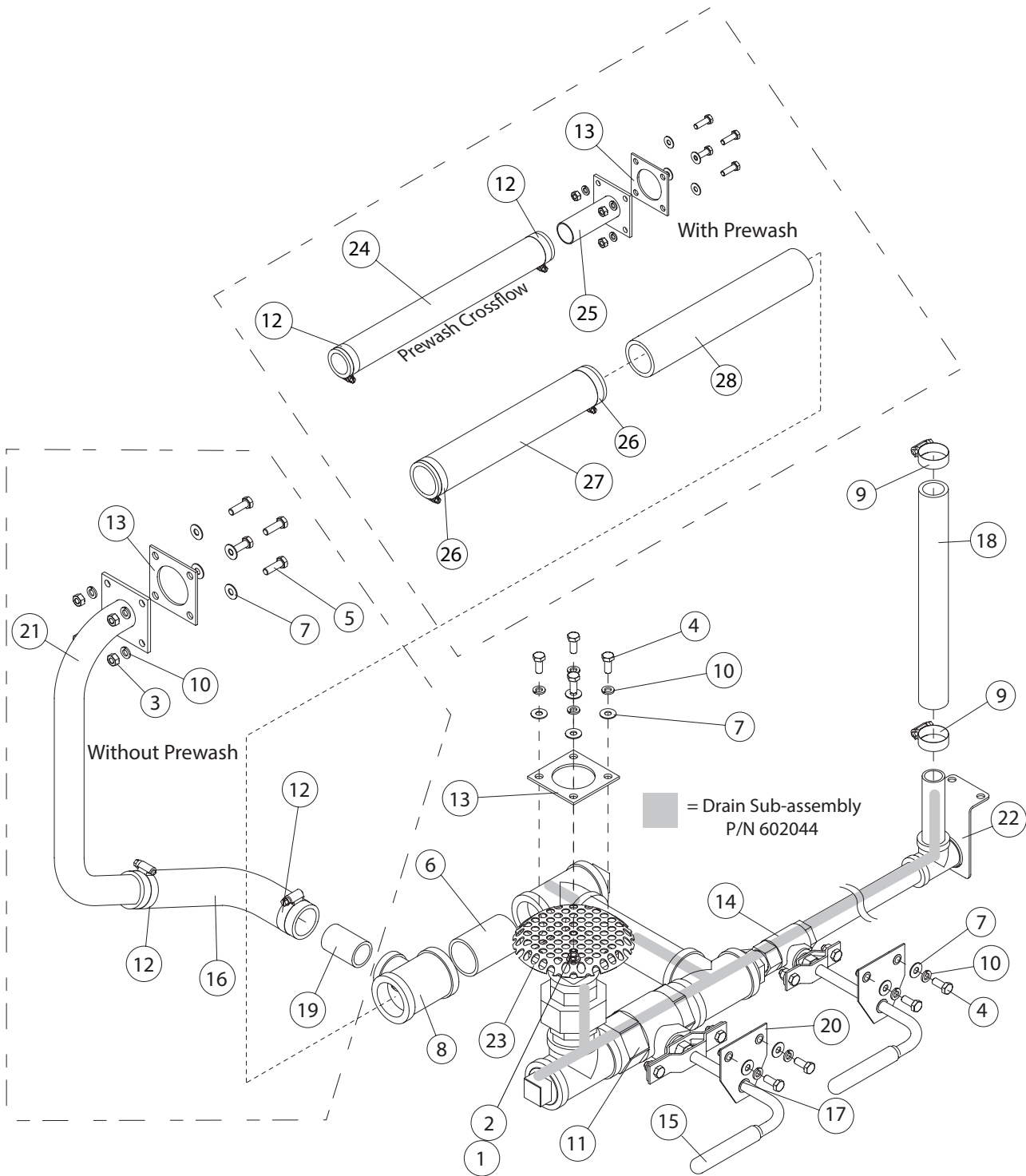

L-R Direction Shown

E54DR with & without Prewash Drain Assembly

Item No.	Part No.	Description	Qty.
1	100003	Hex, Plain Nut, 1/4-20 SST	1
2	106026	Washer, Flat 1/4" SST	1
3	100154	Hex, Plain Nut, 5/16-18 SST	4
4	100739	Bolt, Hex Hd. 5/16-18 x 3/4" SST	8
5	100740	Bolt, Hex Hd. 5/16-18 x 1" SST	4
6	101835	Nipple, 1-1/2" NPT x 2-3/4" Lg. Galv.	1
7	102376	Washer, Flat 5/16 SST	12
8	102543	Tee, 1-1/2" NPT x 1-1/2" NPT x 1" NPT Galv.	1
9	105993	Clamp, Hose M20 Gear-type	2
10	106013	Washer, Lock 5/16 SST	12
11	115117	Valve, Ball 1-1/2" NPT with T-handle	1
12	107340	Clamp, Hose M28 Gear-type	2
13	108345	Gasket, Heater/Standpipe	2
14	115223	Valve, Ball 3/4" NPT with T-handle	1
15	114185	Grip, Drain Handle	2
16	114472	Hose, Overflow	1
17	114817	Bearing, Sleeve 1/2" Dia. Rod, Nylon	2
18	115230	Hose, DR Drain	1
19	204383	Nipple, TOE 1" NPT x 2" Lg. Galv.	1
20	334715	Bracket, Ball Valve Handle Support	2
21	334718	Overflow Weldment	1
22	334902	Bracket, DR Drain Support	1
23	335386	Strainer, Drain 6" Dia.	1
24	207216	Hose, 1-3/8" ID x 17" Lg.	1
25	334719	Stub, Crossflow Weldment	1
26	104165	Clamp, Hose M40 Gear-type	2
27	202240	Hose, 1-7/8" ID x 16-1/2" Lg.	1
28	203005	Nipple, TOE, 1-1/2" NPT x 15-1/2" Lg. Galv.	1

E64 with and without Prewash Drain Assembly

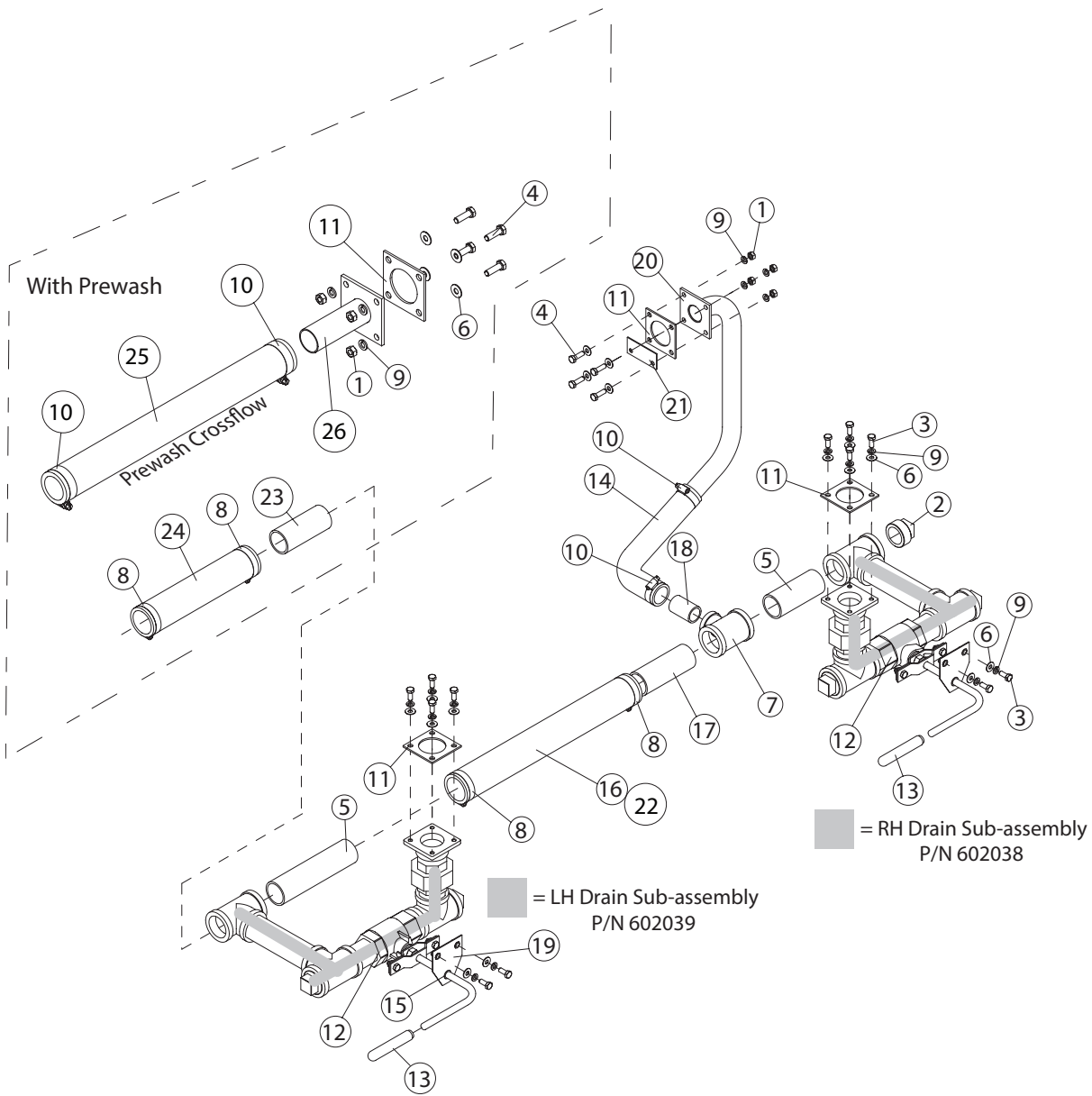

L-R Direction Shown

E64 with and without Prewash Drain Assembly

Item No.	Part No.	Description	Qty.
1	100154	Hex, Plain Nut, 5/16-18 SST	8
2	100587	Plug, 1-1/2" NPT Sq. Head, Galv.	1
3	100739	Bolt, Hex Hd. 5/16-18 x 3/4" SST	12
4	100740	Bolt, Hex Hd. 5/16-18 x 1" SST	8
5	101845	Nipple, 1-1/2" NPT x 4-1/2" Lg. Galv.	2
6	102376	Washer, Flat 5/16 SST	20
7	102543	Tee, 1-1/2" NPT x 1-1/2" NPT x 1" NPT Galv.	2
8	104165	Clamp, Hose M40 Gear-type	2
9	106013	Washer, Lock 5/16 SST	12
10	107340	Clamp, Hose M28 Gear-type	4
11	108345	Gasket, Heater/Standpipe	4
12	115117	Valve, Ball 1-1/2" NPT with T-handle	2
13	114185	Grip, Drain Handle	2
14	114472	Hose, Overflow	2
15	114817	Bearing, Sleeve 1/2" Dia. Rod, Nylon	4
16	202458	Hose, 1-7/8" ID x 18" Lg.	1
17	204272	Nipple, TOE 1-1/2" NPT x 5" Lg. Galv.	1
18	204383	Nipple, TOE 1" NPT x 2" Lg. Galv.	1
19	334715	Bracket, Ball Valve Handle Support	2
20	334718	Overflow Weldment	2
21	334822	Plate, Crossflow, Power Rinse Tank	1
22	206524	Hose, 1-7/8" ID x 23" Lg. (PW only)	1
23	111784	Nipple, TOE 1-1/2" NPT x 4" Lg. (PW only)	1
24	202869	Hose, 1-7/*" ID x 10-1/2" Lg. (PW only)	1
25	207215	Hose, 1-3/8" ID x 15" Lg. (PW only)	1
26	334719	Stub, Weldment Crossflow (PW only)	1

E84 Drain Assembly

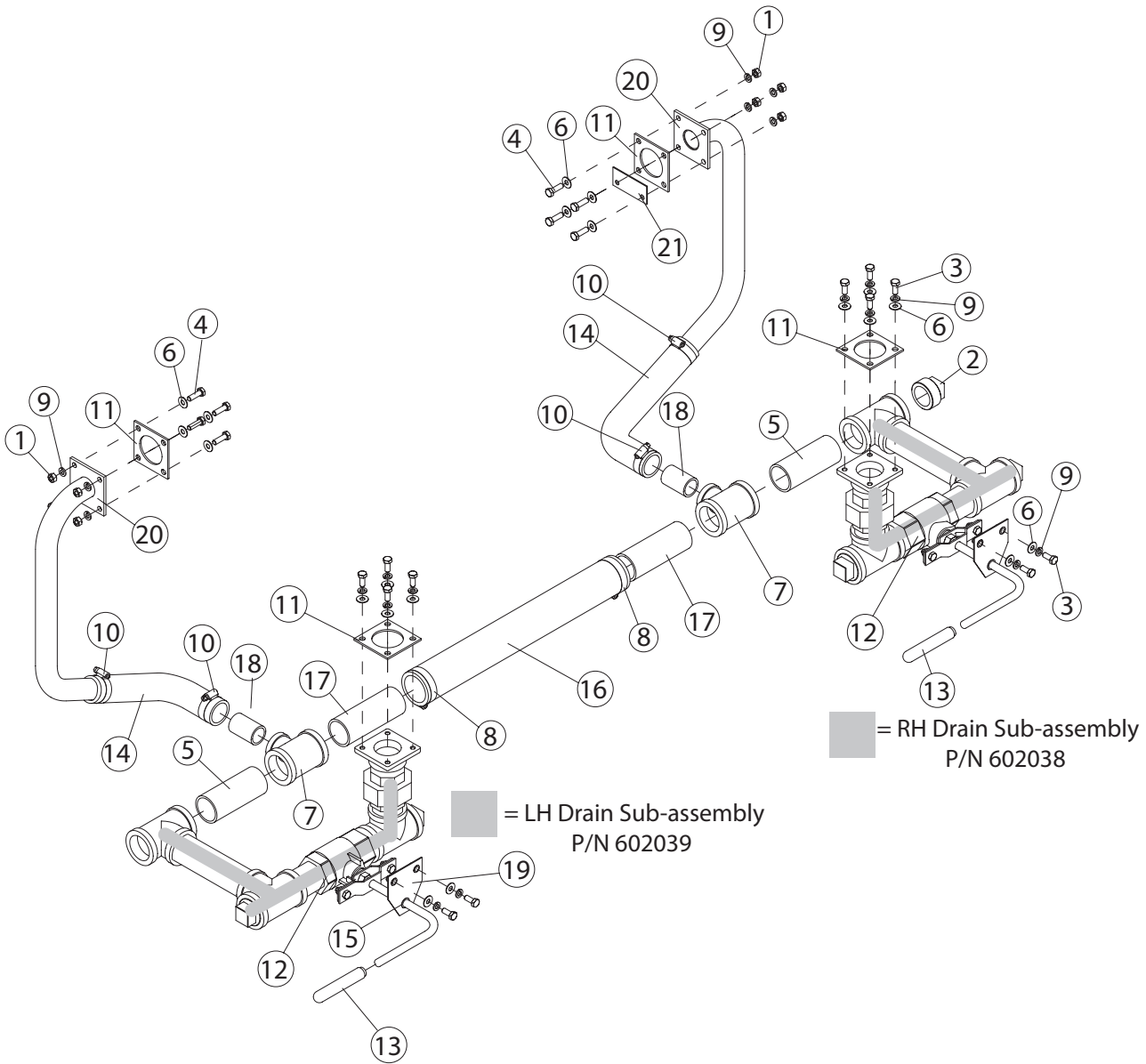

L-R Direction Shown

Item No.	Part No.	Description	Qty.
1	100154	Hex, Plain Nut, 5/16-18 SST	8
2	100587	Plug, 1-1/2" NPT Sq. Head, Galv.	1
3	100739	Bolt, Hex Hd. 5/16-18 x 3/4" SST	12
4	100740	Bolt, Hex Hd. 5/16-18 x 1" SST	8
5	100043	Nipple, 1-1/2" NPT x Close. Galv.	2
6	102376	Washer, Flat 5/16 SST	20
7	102543	Tee, 1-1/2" NPT x 1-1/2" NPT x 1" NPT Galv.	2
8	104165	Clamp, Hose M40 Gear-type	2
9	106013	Washer, Lock 5/16 SST	20
10	107340	Clamp, Hose M28 Gear-type	4
11	108345	Gasket, Heater/Standpipe	4
12	115117	Valve, Ball 1-1/2" NPT with T-handle	2
13	114185	Grip, Drain Handle	2
14	114472	Hose, Overflow	2
15	114817	Bearing, Sleeve 1/2" Dia. Rod, Nylon	4
16	206524	Hose, 1-7/8" ID x 23" Lg.	1
17	107563	Nipple, TOE 1-1/2" NPT x 13" Lg. Galv.	1
18	204383	Nipple, TOE 1" NPT x 2" Lg. Galv.	1
19	334715	Bracket, Ball Valve Handle Support	2
20	334718	Overflow Weldment	2
21	334822	Plate, Crossflow, Power Rinse Tank	1

E84 With Prewash Drain Assembly

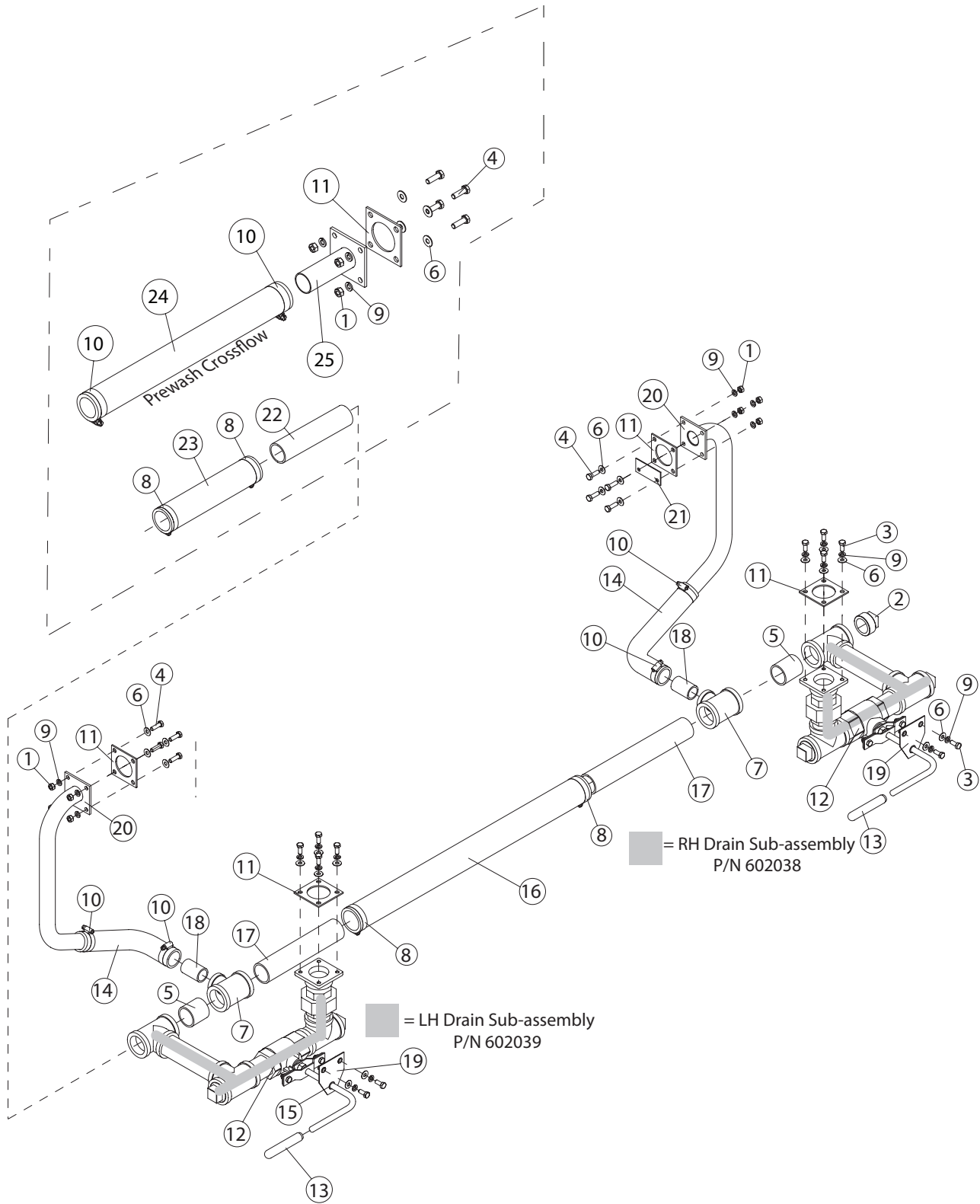

L-R Direction Shown

Item No.	Part No.	Description	Qty.
1	100154	Hex, Plain Nut, 5/16-18 SST	8
2	100587	Plug, 1-1/2" NPT Sq. Head, Galv.	1
3	100739	Bolt, Hex Hd. 5/16-18 x 3/4" SST	12
4	100740	Bolt, Hex Hd. 5/16-18 x 1" SST	8
5	100043	Nipple, 1-1/2" NPT x Close. Galv.	2
6	102376	Washer, Flat 5/16 SST	20
7	102543	Tee, 1-1/2" NPT x 1-1/2" NPT x 1" NPT Galv.	2
8	104165	Clamp, Hose M40 Gear-type	2
9	106013	Washer, Lock 5/16 SST	20
10	107340	Clamp, Hose M28 Gear-type	4
11	108345	Gasket, Heater/Standpipe	4
12	115117	Valve, Ball 1-1/2" NPT with T-handle	2
13	114185	Grip, Drain Handle	2
14	114472	Hose, Overflow	2
15	114817	Bearing, Sleeve 1/2" Dia. Rod, Nylon	4
16	206524	Hose, 1-7/8" ID x 23" Lg.	1
17	107563	Nipple, TOE 1-1/2" NPT x 13" Lg. Galv.	1
18	204383	Nipple, TOE 1" NPT x 2" Lg. Galv.	1
19	334715	Bracket, Ball Valve Handle Support	2
20	334718	Overflow Weldment	2
21	334822	Plate, Crossflow, Power Rinse Tank	1
22	105634	Nipple, TOE 1-1/2" NPT x 7" Lg.	1
23	202869	Hose, 1-7/8" ID x 10-1/2" Lg.	1
24	207215	Hose, 1-3/8" ID x 15" Lg.	1
25	334719	Stub, Weldment Crossflow	1

Final Rinse Drain Assembly

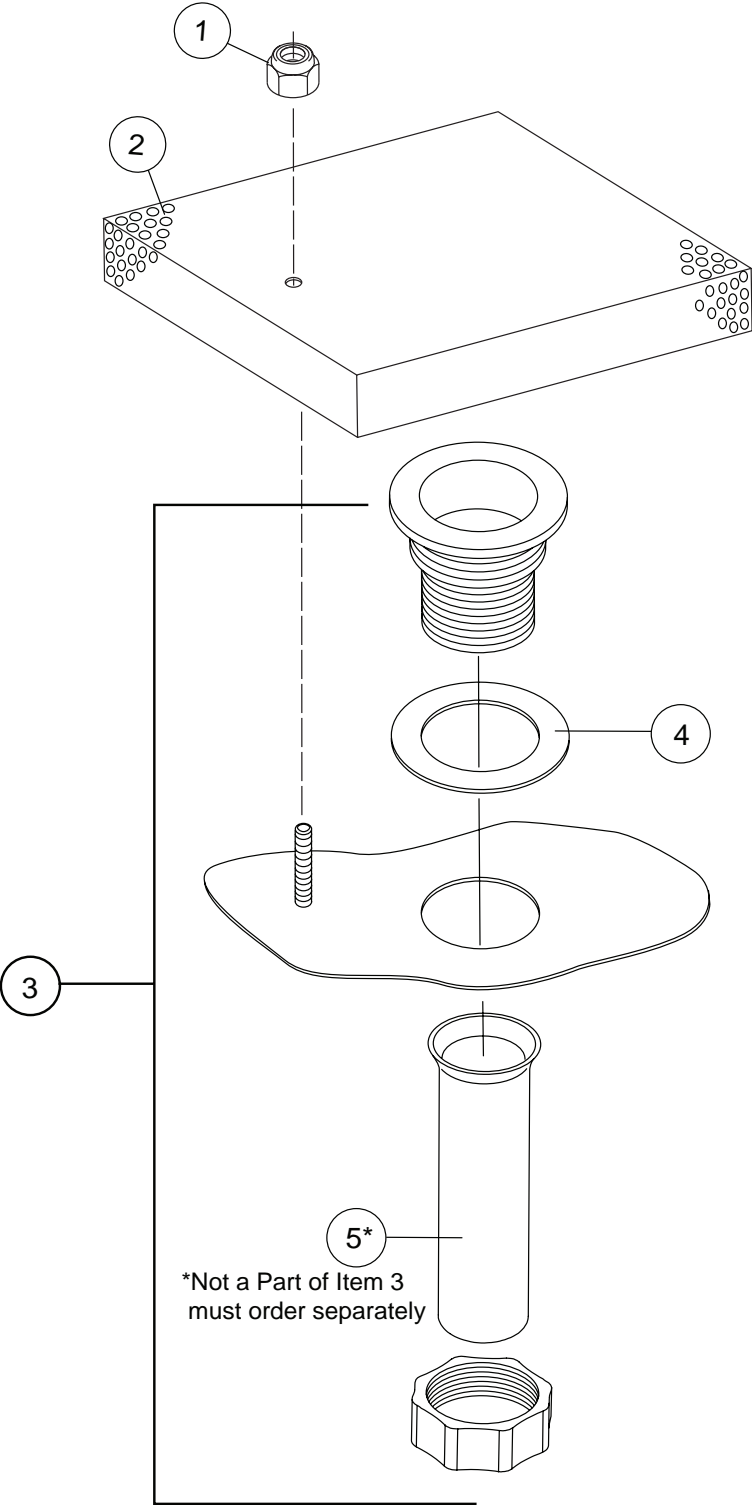

Final Rinse Drain Assembly

Item No.	Part No.	Description	Qty.
1	100141	Nut, Grip 1/4-20	1
2	305218	Strainer, F/R Drain	1
3	107342	Drain Basket Assy. (Includes Item 4 and nut)	1
4	112045	Washer, Tailpiece	1
5	107473	Tailpiece (Not included in Item 3 must order separately)	1

22" Prewash Door Assembly

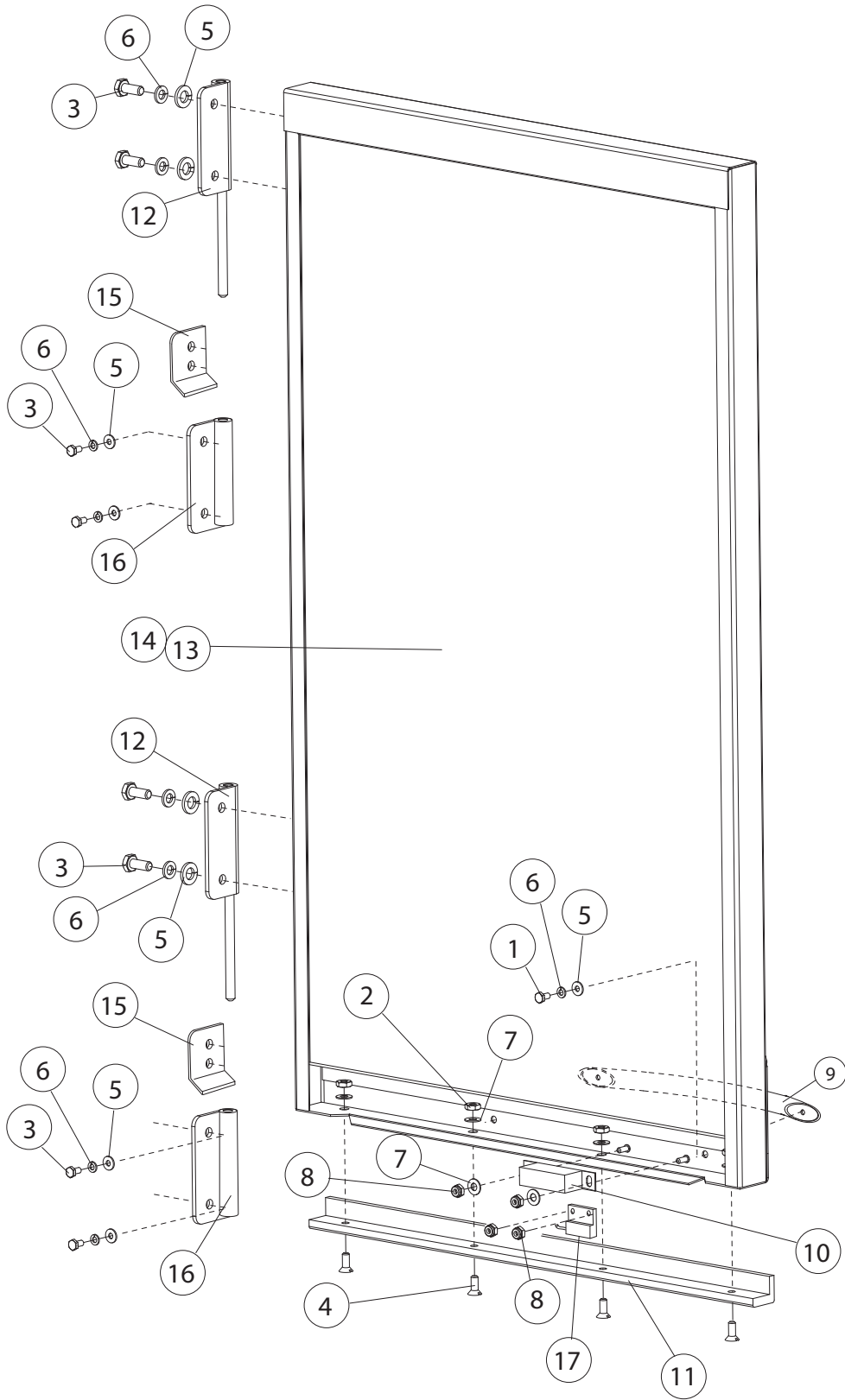

Item No.	Part No.	Description	Qty.
1	100074	Bolt, Hex Head, 1/4-20 x 1/2" SST	2
2	100194	Nut, Hex Grip 10-32 SST	4
3	100735	Bolt, Hex Head 1/4-20 x 5/8" SST	4
4	100754	Screw, Flat Head 10-32 x 1/2" SST	4
5	106026	Washer, Flat 1/4" SST	10
6	106482	Washer, Lock 1/4" Split SST	8
7	107033	Washer, Flat SST	6
8	108954	Nut, Hex Grip 6-32 SST w/nylon insert	4
9	115665	Handle, Door	1
10	113937	Magnet, Reed Switch	1
11	115316	Strip, Wear Bottom Door <i>(Prior to S/N RE15067977)</i>	1
—	116175	Strip, Wear Bottom Door <i>(Beginning with S/N RE15067977 and above)</i>	1
12	335152	Hinge, Door Weldment	2
13	335293	Door, 16" Standard Hood <i>(Prior to S/N RE15067977)</i>	1
—	336682	Door, 16" Standard Hood <i>(Beginning with S/N RE15067977 and above)</i>	1
14	335296	Door, 16" High Hood <i>(Prior to S/N RE15067977)</i>	1
—	TBD	Door, 16" High Hood <i>(Beginning with S/N RE15067977 and above)</i>	1
15	335977	Stop, Hinged Door Removal	2
16	335154	Hinge, Hood Side <i>(Prior to S/N RE15067977)</i>	2
—	TBD	Hinge, Hood Side <i>(Beginning with S/N RE15067977 and above)</i>	2
17	113721	Switch, Door Safety	1

E44 and E54 Door Assemblies

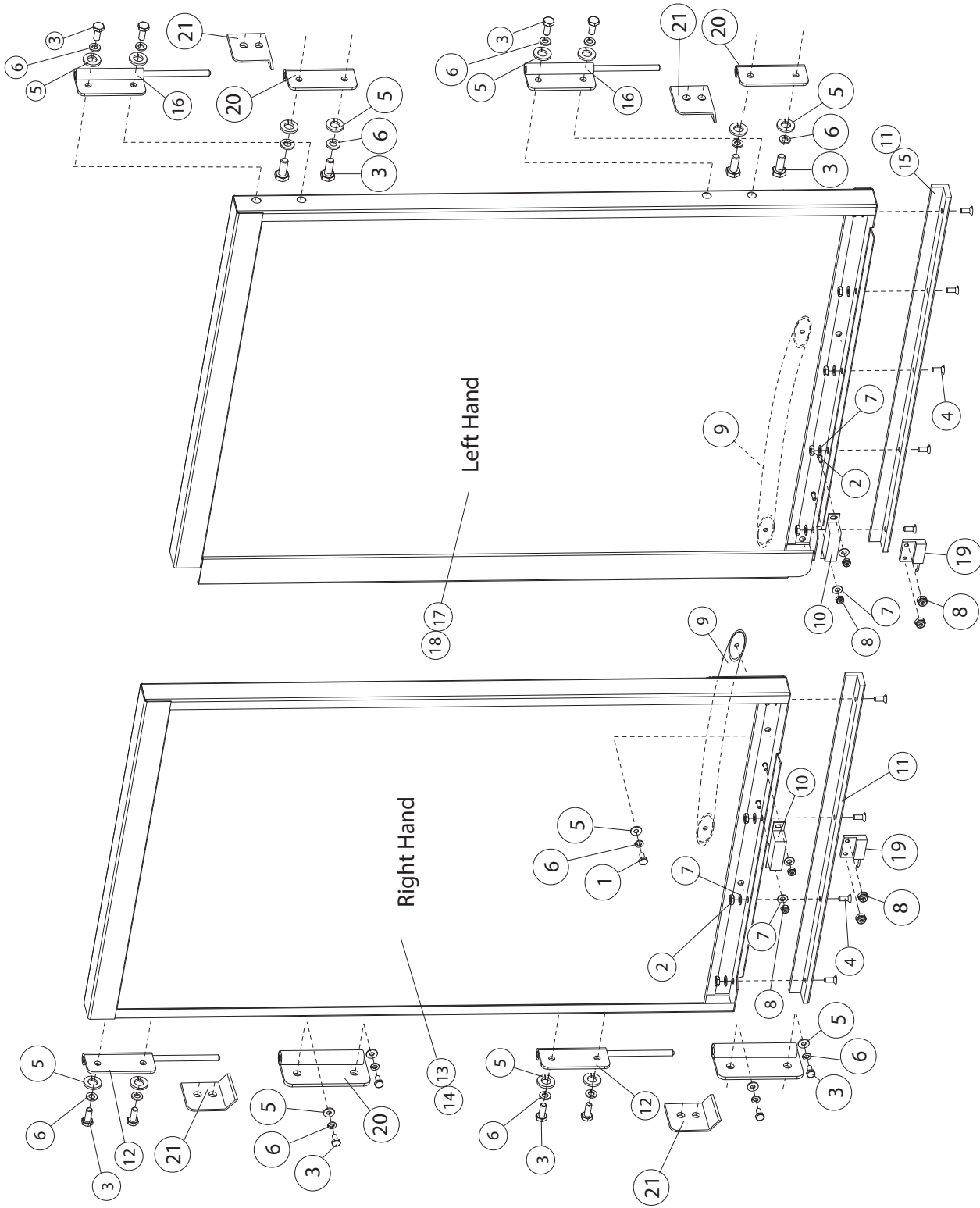

E44 and E54 Door Assemblies

Item No.	Part No.	Description	Qty.
1	100074	Bolt, Hex Head, 1/4-20 x 1/2" SST	4
2	100194	Nut, Hex Grip 10-32 SST	9
3	100735	Bolt, Hex Head 1/4-20 x 5/8" SST	8
4	100754	Screw, Flat Head 10-32 x 1/2" SST	9
5	106026	Washer, Flat 1/4" SST	19
6	106482	Washer, Lock 1/4" Split SST	19
7	107033	Washer, Flat SST	13
8	108954	Nut, Hex Grip 6-32 SST w/nylon insert	8
9	115665	Handle, Door (Beginning in August 2015)	2
10	113937	Magnet, Reed Switch	2
11	115316	Strip, Wear Bottom Door (<i>Prior to S/N RE15067977</i>)	1
—	115612	Strip, Wear Bottom Door (<i>Beginning with S/N RE15067977 and above</i>)	2
12	335152	Hinge, RH Door Weldment	2
13	335293	Door, 16" RH Standard Hood (<i>Prior to S/N RE15067977</i>)	1
—	336676	Door, RH Standard Hood (<i>Beginning with S/N RE15067977 and above</i>)	1
14	335296	Door, 16" RH High Hood (<i>Prior to S/N RE15067977</i>)	1
—	TBD	Door, RH High Hood (<i>Beginning with S/N RE15067977 and above</i>)	1
15	115315	Strip, Wear Bottom 20-1/2" Door	1
16	335151	Hinge, LH Door Weldment	2
17	335294	Door, 20-1/2" LH Standard Hood (<i>Prior to S/N RE15067977</i>)	1
—	336675	Door, LH Standard Hood (<i>Beginning with S/N RE15067977 and above</i>)	1
18	335296	Door, 20-1/2" LH High Hood (<i>Prior to S/N RE15067977</i>)	1
—	TBD	Door, LH High Hood (<i>Beginning with S/N RE15067977 and above</i>)	1
19	113721	Switch, Door Safety	1
20	335154	Hinge, Hood Side (<i>Prior to S/N RE15067977</i>)	4
—	TBD	Hinge, Hood Side (<i>Beginning with S/N RE15067977 and above</i>)	4
21	335977	Stop, Hinged Door Removal	4

E64, E84 and 36" Prewash Door Assemblies

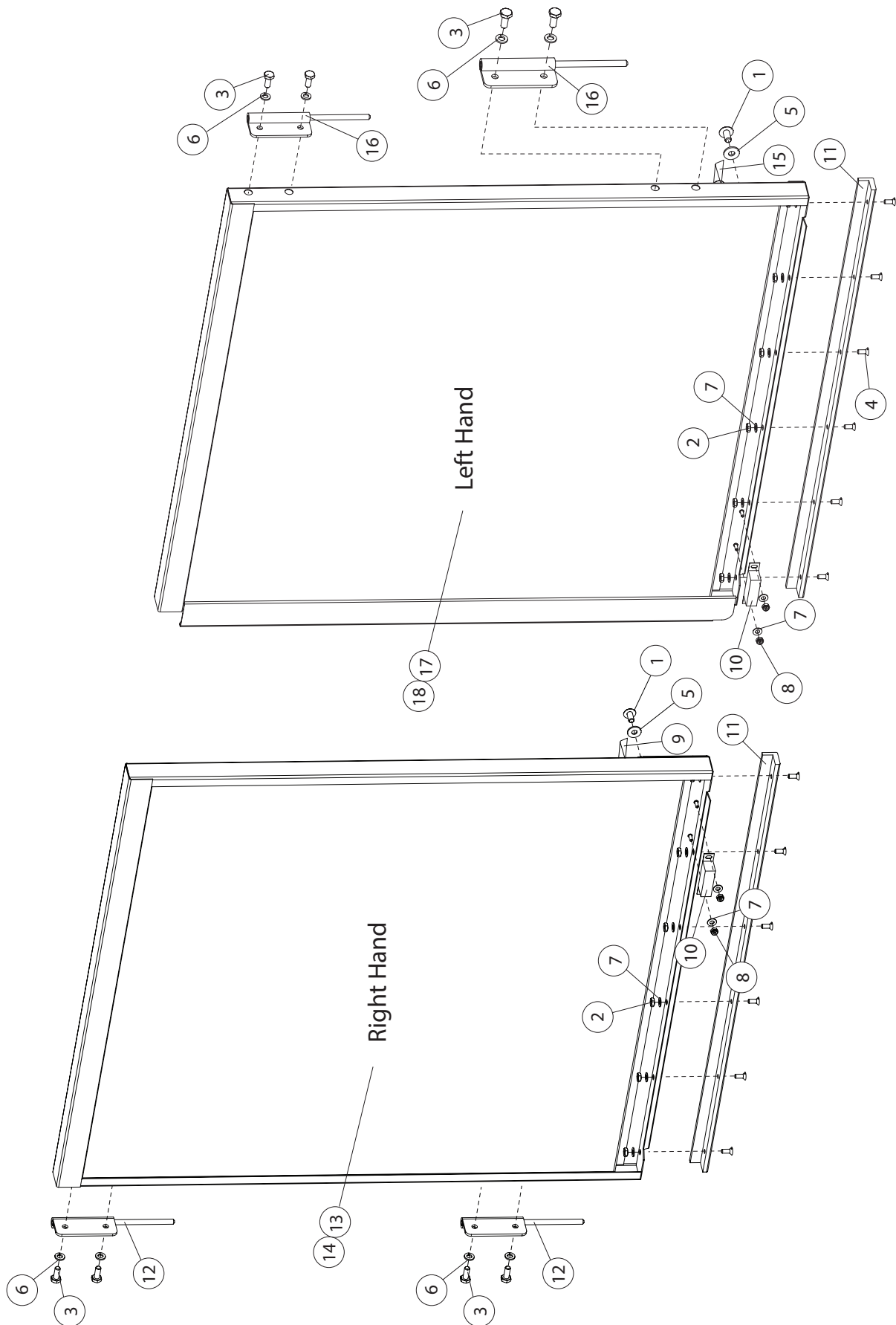

E64, E84 and 36" Prewash Door Assemblies

Item No.	Part No.	Description	Qty.
1	100073	Screw, Truss Head, 1/4-20 x 1/2" SST	6
2	100194	Nut, Hex Grip 10-32 SST	12
3	100735	Bolt, Hex Head 1/4-20 x 5/8" SST	8
4	100754	Screw, Flat hHead 10-32 x 1/2" SST	12
5	106026	Washer, Flat 1/4" SST	6
6	106482	Washer, Lock 1/4" Split SST	8
7	107033	Washer, Flat 0.208" SST	16
8	108954	Nut, Hex Grip 6-32 SST w/nylon insert	4
9	335266	Handle, 26" RH Door	1
10	113937	Magnet, Reed Switch	2
11	115314	Strip, Wear Bottom 26" Door	2
12	335152	Hinge, 26" RH Door Weldment	2
13	335258	Door, 26" RH Standard Hood (E64/84/36"PW)	1
14	335264	Door, 26" RH High-Hood (E64/84/36"PW)	1
15	335256	Handle, 26" LH Door	1
16	335151	Hinge, 26" LH Door Weldment	2
17	335257	Door, 26" LH Standard Hood (E64/84)	1
18	335263	Door, 26" LH High Hood (E64/84)	1

Extended Vent Cowls and Splash Shields

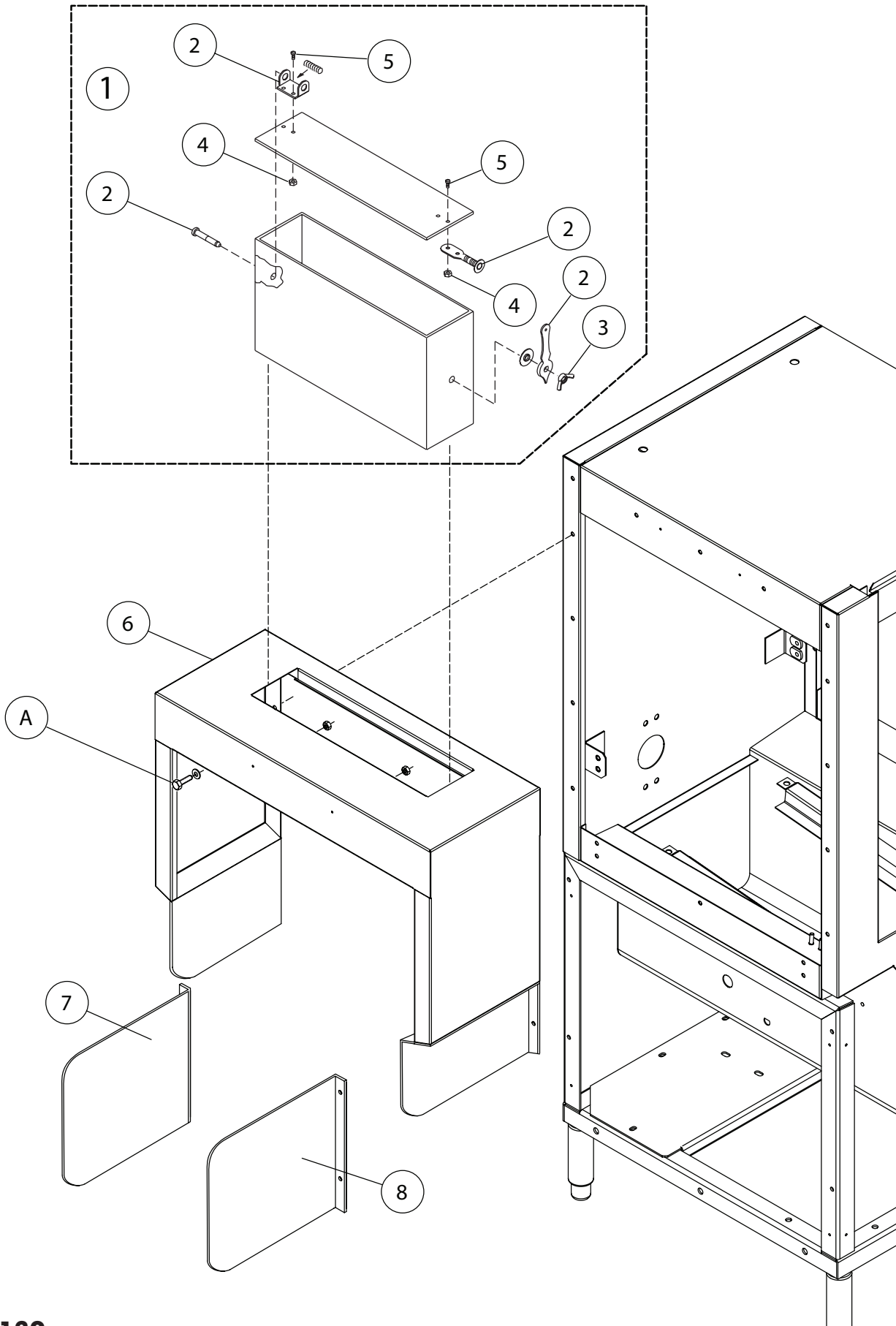

Item No.	Part No.	Description	Qty.
1	401487	Vent Stack Assembly (Includes Items 2-5)	2
2	201589	Regulator Assembly	2
3	112258	Nut Wing 1/4-20 SST	2
4	108954	Nut, Grip 6-32 w/Nylon Insert	4
5	104883	Screw 6-32 x 3/8" Round Head	4
6	328344	Vent Cowl	2
7	328995-1	Shield, LH Splash	1
8	328995-2	Shield, RH Splash	1
-	401487	Vent Hood Assembly (Includes Items 1-5)	

A **Vent Cowl Fasteners (Qty per Cowl)**

100734	Bolt 1/4-20 x 1/2 Hex Head SST	4
106026	Washer Flat 1/4"	4
106482	Washer Lock 1/4 Split	4
100003	Nut Plain 1/4-20	4

Standard Vent Cowl

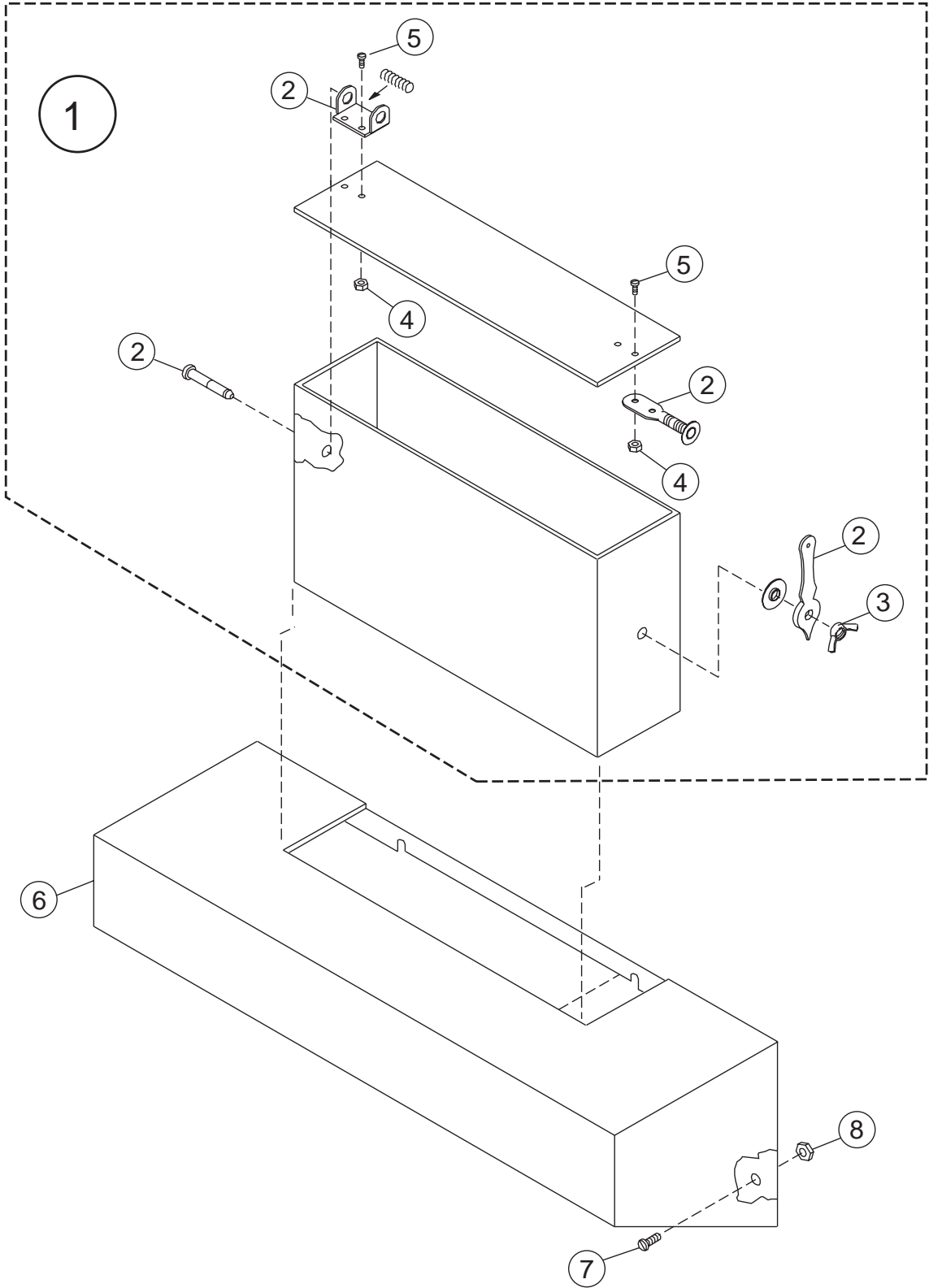

Item No.	Part No.	Description	Qty.
1	401487	Vent Stack Assembly (Includes items 2-5)	2
2	201589	Regulator Assembly	2
3	112258	Nut, Wing 1/4-20 SST	2
4	108954	Nut, Grip 6-32 w/Nylon Insert	8
5	104883	Screw 6-32 x 3/8 Round Head	8
6	307228	Vent Cowl	2
7	100734	Bolt 1/4-20 x 1/2" Hex Head	4
8	100141	Nut Grip 1/4-20	8
-	401889-S	Vent Cowl Assembly (Includes Items 1-10)	

Single Tank Hot Water Coil (HWC) Heat

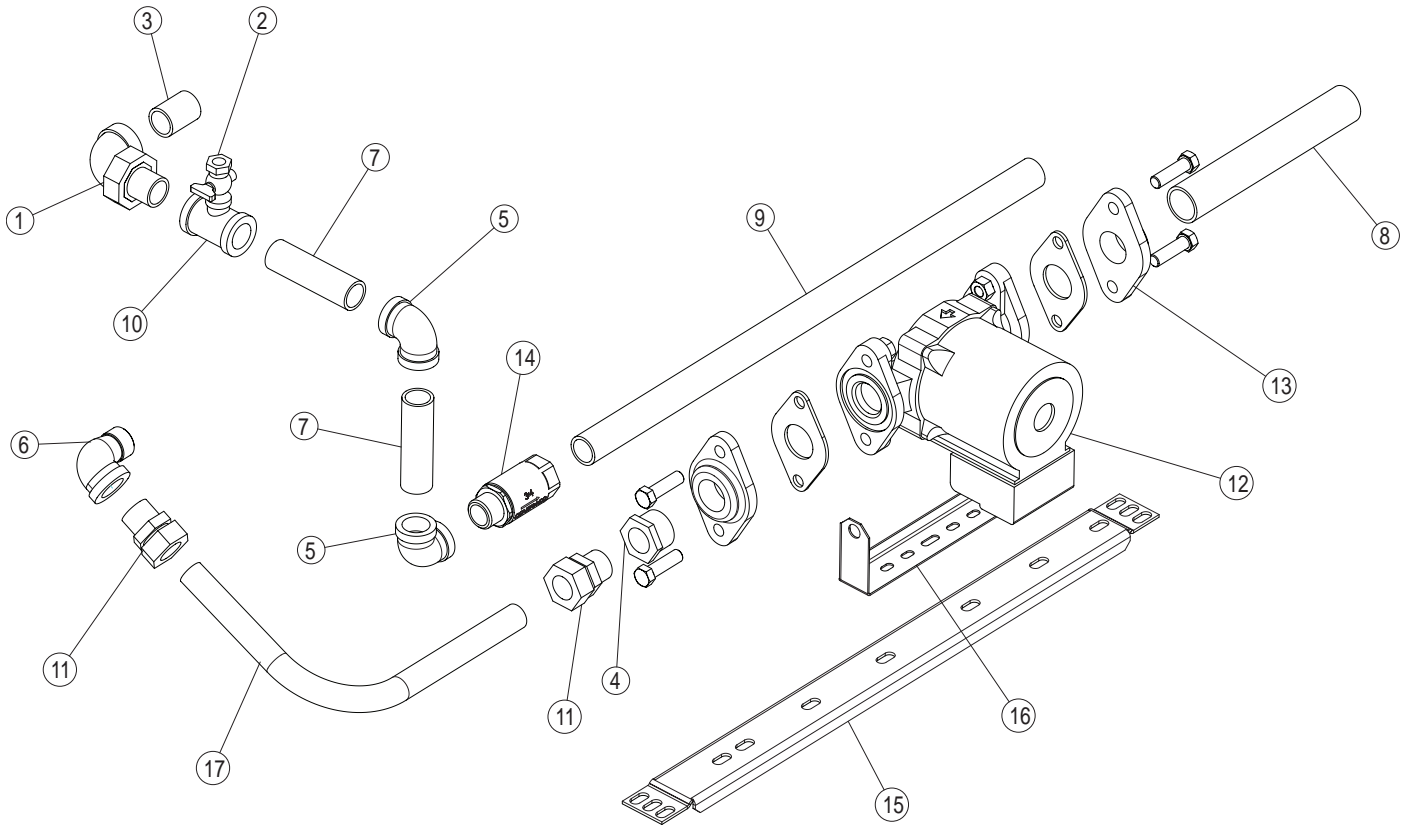

Single Tank Hot Water Coil (HWC) Heat

Item No.	Part No.	Description	Qty.
1	100118	Union Elbow, 3/4" NPT Male Brass	1
2	100123	Petcock 1/4" Female Brass	1
3	100184	Nipple, 3/4" NPT x Close Brass	1
4	102442	Bushing Reducing, 1" NPT x 3/4" NPT Brass	1
5	102396	Elbow 3/4" NPT x 90° Brass	2
6	102444	Elbow Street 3/4"NPT x 90° Brass	1
7	102490	Nipple 3/4" NPT x 3-1/2"Lg. Brass	2
8	102775	Nipple, 1" NPT, 8"Lg. Brass	1
9	103486	Nipple 3/4" NPT x 22" Lg. Brass	1
10	107418	Tee 3/4" x 3/4" 1/4" MPT Brass	1
11	109879	Fitting, Compression 7/8 OD x 3/4 MPT Brass	2
12	111854	Pump,HW Recirculator, Bronze	1
13	111860	Flange kit, 1" NPT Bronze Grundfoss	1
14	114463	Valve Check, 3/4MxF NPT Brass spring loaded ball	1
15	319273	Booster, Support, Channel	1
16	332841	Bracket, Support, HW Coil Pump E-Rack	1

Two Tank Hot Water Coil (HWC) Heat

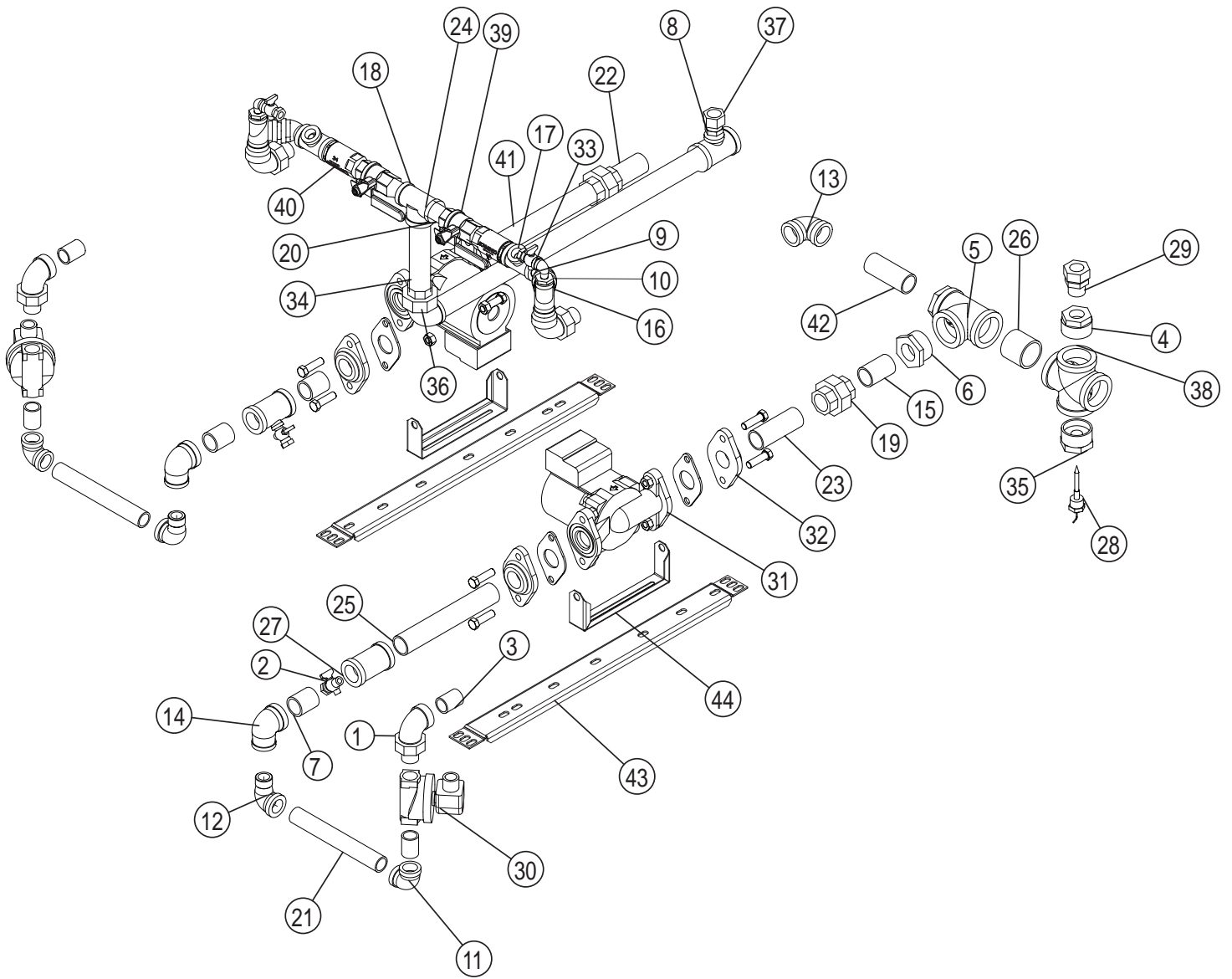

Two Tank Hot Water Coil (HWC) Heat

Item No.	Part No.	Description	Qty.
1	100118	Union Elbow, 3/4" NPT Male Brass	4
2	100123	Petcock 1/4" NPT Closs Brass	4
3	100184	Nipple, Close 3/4" NPT Brass	10
4	100595	Bushing, Reducer 1-1/2" x 3/4" Brass	1
5	100596	Tee, 1-1/2" NPT Brass	1
6	100613	Bushing Reducing, 1-1/2"NPT Brass	2
7	101000	Nipple, Close 1" NPT, Brass	3
8	101026	Tee, Red, 1" x 1" x 1/2" NPT Brass	1
9	101261	Elbow Street, 1/4" x NPT 90° Brass	2
10	102388	Bushing, Reducing 1/2" NPT x 1/4" NPT Brass	2
11	102442	Elbow 3/4" NPT x 90° Brass	2
12	102444	Elbow Street 3/4" NPT x 90° Brass	2
13	102448	Elbow 1" NPT x 90° Brass	2
14	102451	Elbow Reducing, 1"NPT X 3/4"NPT x 90° Brass	1
15	102472	Nipple, 1" x 2" NPT Brass	1
16	102525	Tee, Reducing 3/4" x 1/2" x 3/4" NPT Brass	2
17	102526	Tee, Reducing 3/4" x 3/4" X 1/2" NPT Brass	2
18	102527	Tee Reducing 3/4" x 3/4" x 1" NPT Brass	1
19	102551	Union, 1" NPT Brass	2
20	102651	Nipple, 3/4" NPT x 2" Lg. Brass	2
21	102666	Nipple 3/4" NPT 7-1/2" LG.	2
22	102761	Nipple 1" NPT x 3" Lg.	1
23	102762	Nipple 1"NPT x 3-1/2" Lg.	1
24	102771	Nipple 1"NPT x 6" Lg.	1
25	102775	Nipple 1" NPT x 8" Lg.	1
26	103554	Nipple, 1-1/2" x Close Brass	1
27	106709	Tee, Red 1" x 1" x 1/4" NPT Brass	2
28	107440	Thermometer 8 ft. Flange	1
29	109879	Fitting, Comp 7/8 OD x 3/4"MPT Brass	1
30	109887	Valve Solenoid, 3/4" NPT Brass Steam	2
31	111854	Pump HW Recirculator Bronze	2
32	111860	Flange Kit 1" NPT Bronze Grundfoss Pump	2
33	113706	Elbow Street 3/4" x 45C Brass	1
34	113838	Union Elbow 3/4" 45 90° Brass	1
35	113839	Bushing Reducing 1-1/2" NPT Brass	1
36	114081	Nipple, 1" NPT x 24" Lg. Brass	1
37	114384	Fitting Comp 7/8 OD x 1/2 MPT Brass	1
38	114459	Cross 1-1/2" NPT Brass	1
39	114461	Valve Balll 3/4 FNPT Brass w/ setting indicator	2
40	114463	Valve Check 3/4" MxF NPT Brass spring loaded ball	2
41	114476	Nipple 1" NPT x 10-1/4" Lg. Brass	1
42	114477	Nipple, 1" NPT x 3-1/4" Lg. Brass	1
43	319273	Booster Support Channel	2
44	332841	Bracket Support HW Coil Pump E-Rack	2

24" Sideloader

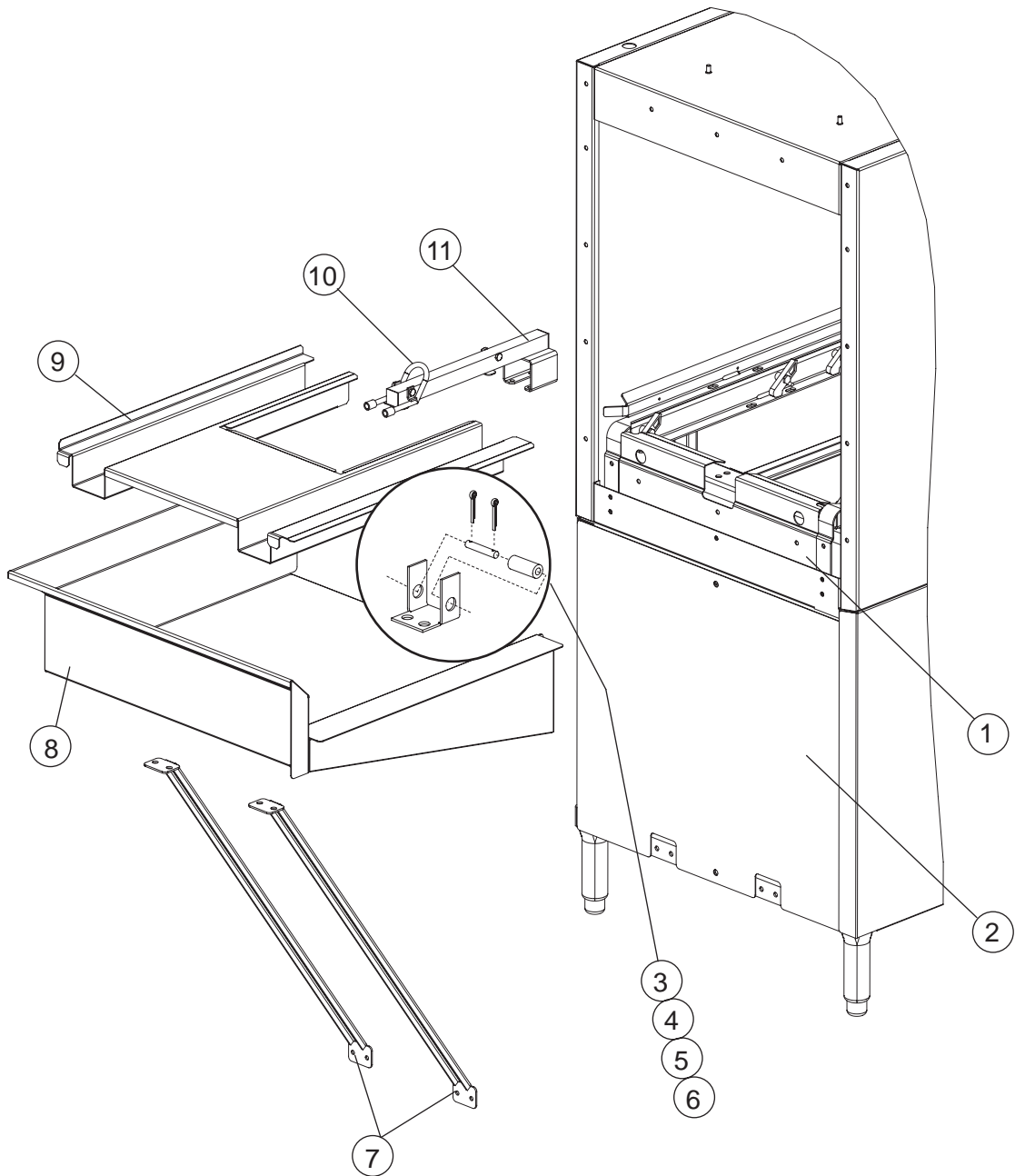

Item No.	Part No.	Description	Qty.
1	329927	Baffle, Table Flange, Sideloader with cut out	1
2	329352	Panel, End	1
3	312336	Bracket, Bar Support	1
4	312335	Pawl, Pin, Bar Support	1
5	109282	Spacer	1
6	108875	Pin, Cotter 3/32" x 1/2"	2
7	328955	Bracket Support, Sideloader	2
8	328941	24" L-R Sideloader	1
—	328942	24" R-L Sideloader	1
9	329317-1	24" Track, R-L Sideloader	1
—	329318-1	24" Track, L-R Sideloader	1
10	313598	Lever, Pawl	1
11	328914	Bar, Pawl 13-1/2" Lg.	1

30" Sideloader

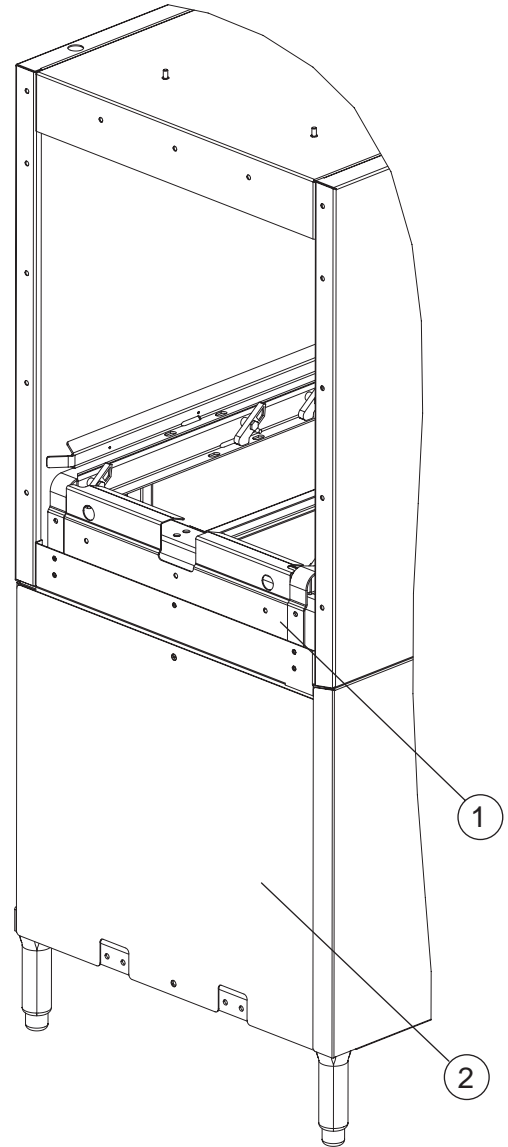
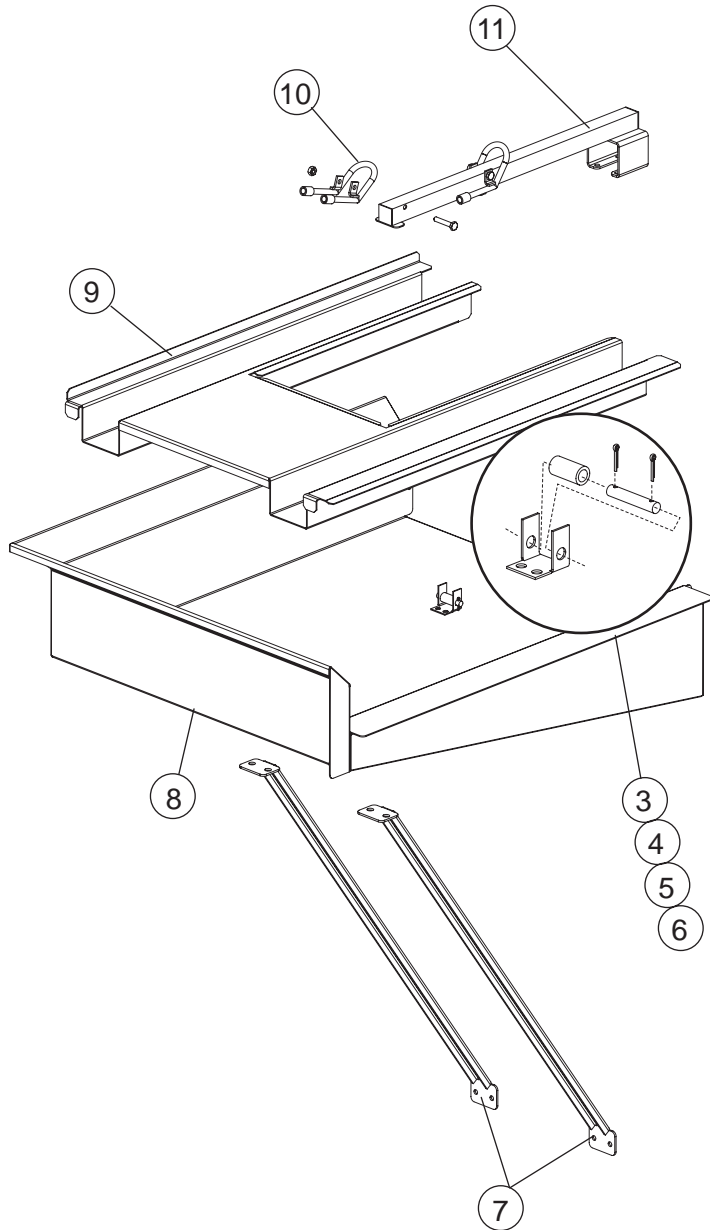

Item No.	Part No.	Description	Qty.
1	329927	Baffle, Table Flange, Sideloader with cut out	1
2	329352	Panel, End	1
3	312336	Bracket, Bar Support	2
4	312335	Pawl, Pin, Bar Support	2
5	109282	Spacer	2
6	108875	Pin, Cotter 3/32" x 1/2"	4
7	328955	Bracket Support, Sideloader	2
8	328943	30" L-R Sideloader	1
—	328944	30" R-L Sideloader	1
9	329317-2	30" Track, R-L Sideloader	1
—	329318-2	30" Track, L-R Sideloader	1
10	313598	Lever, Pawl	2
11	328915	Bar, Pawl 19-1/2" Lg.	1

Dish racks

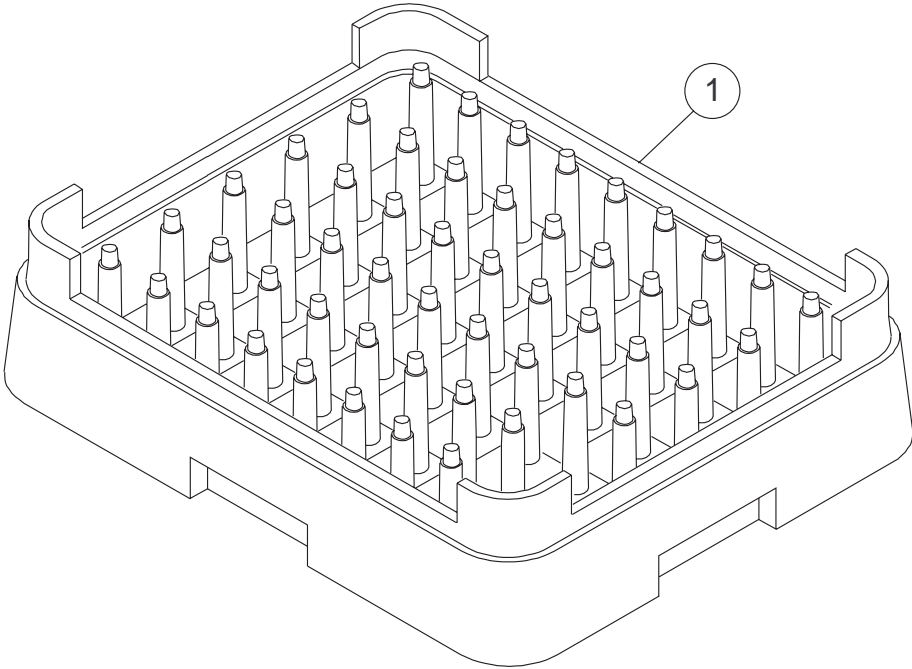
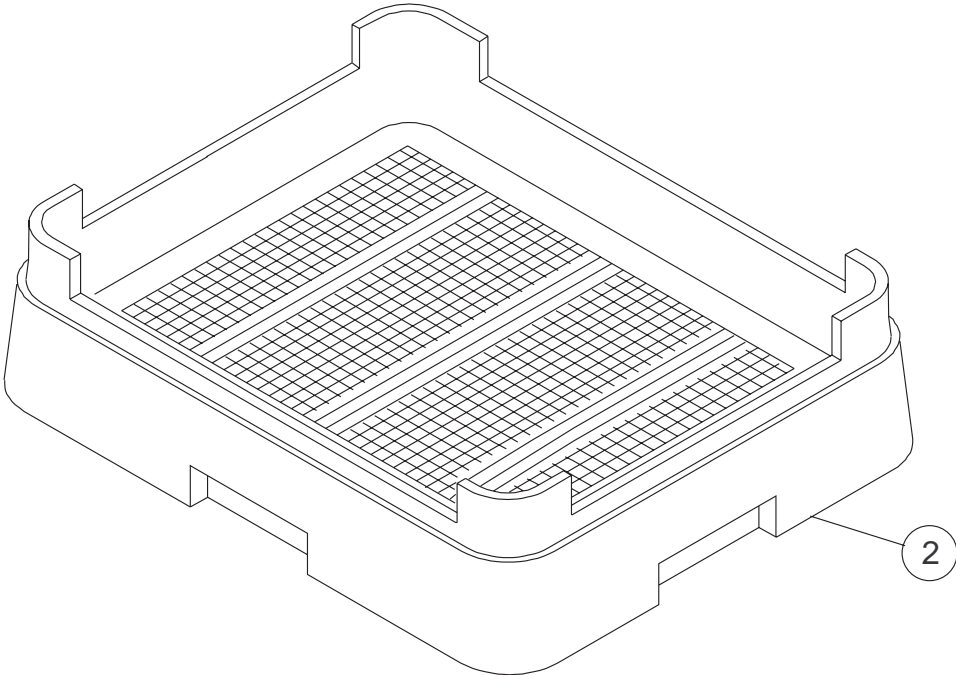

Item No.	Part No.	Description	Qty.
1	101285	Rack Peg	1
2	101273	Rack Combination	1

***This Page
Intentionally
Left
Blank***

Electrical Schematics

Illustration	Page
Single Tank Electric/Steam	148
Single Tank Electric/Steam Hot Water Coil.....	149
Two Tank Electric/Steam	150
Two Tank Electric/Steam Hot Water Coil.....	151
12KW and 22KW Electric Booster.....	152
15KW and 24KW Electric Booster.....	153
30KW Heat Recovery Electric Booster	154
Thermistor Connections.....	155
90/180 Rack Advance Connections	156

MODELS COVERED BY THIS DRAWING	
E66DRPW	E44DR
E76DRPW	E54DR

NOTES:

1. WHEN TABLE LIMIT SWITCH IS USED REMOVE JUMPER AND CONNECT LEADS BETWEEN WIRES 3 AND 11 ON TERMINAL BLOCK IN PANEL.
2. 4TH POLE USED FOR NEUTRAL ON THREE PHASE 5 WIRE SYSTEM ONLY.
3. NEUTRAL USED FOR DR HEAT ON THREE PHASE 5 WIRE SYSTEM.

1CR	DOOR SAFETY RELAY
1M	DRIVE MOTOR CONTACTOR
1MOL	DRIVE MOTOR OVERLOAD
2M	PREWASH MOTOR CONTACTOR
2MOL	PREWASH MOTOR OVERLOAD
3M	WASH MOTOR CONTACTOR
3MOL	WASH MOTOR OVERLOAD
6M	DR MOTOR RELAY
BC-	BOOSTER CONTACTOR/STEAM VALVE
BWR	BLOWER
CWV	COLD WATER VALVE
DC	DUAL RINSE HEAT CONTACTOR
DSW	DRIVE SWITCH (FRONT FEED ONLY)
DTV	DRAIN TEMPERING VALVE
FRSW	FINAL RINSE SWITCH
FU	FUSE/FUSE BLOCK
FV	FILL VALVE
HLTS	HIGH LIMIT THERMOSTAT
JSW	JAM SWITCH
PCB	POWER SWITCH/CIRCUIT BREAKER
PW	PREWASH DOOR SWITCH
PWV	PREWASH FILL VALVE
PWFSW	PREWASH TANK FLOAT SWITCH
RC	RINSE HEAT CONTACTOR
RSW	RACK SWITCH
RV	RINSE VALVE
T1	CONTROL TRANSFORMER
TLS	TABLE LIMIT SWITCH
TS	THERMOSTAT
W	WASH DOOR SWITCH
WC	WASH HEAT CONTACTOR/STEAM VALVE
WFSW	WASH TANK FLOAT SWITCH

HARNESS ASSEMBLIES

H1	6 PIN ALL MODELS
H2	6 PIN ALL MODELS
H3	8 PIN ALL MODELS
H4	2 PIN ALL MODELS
H5	2 PIN ALL MODELS
H6	2 PIN ALL MODELS
H7	2 PIN ALL MODELS

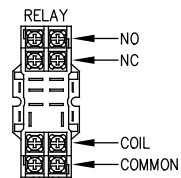
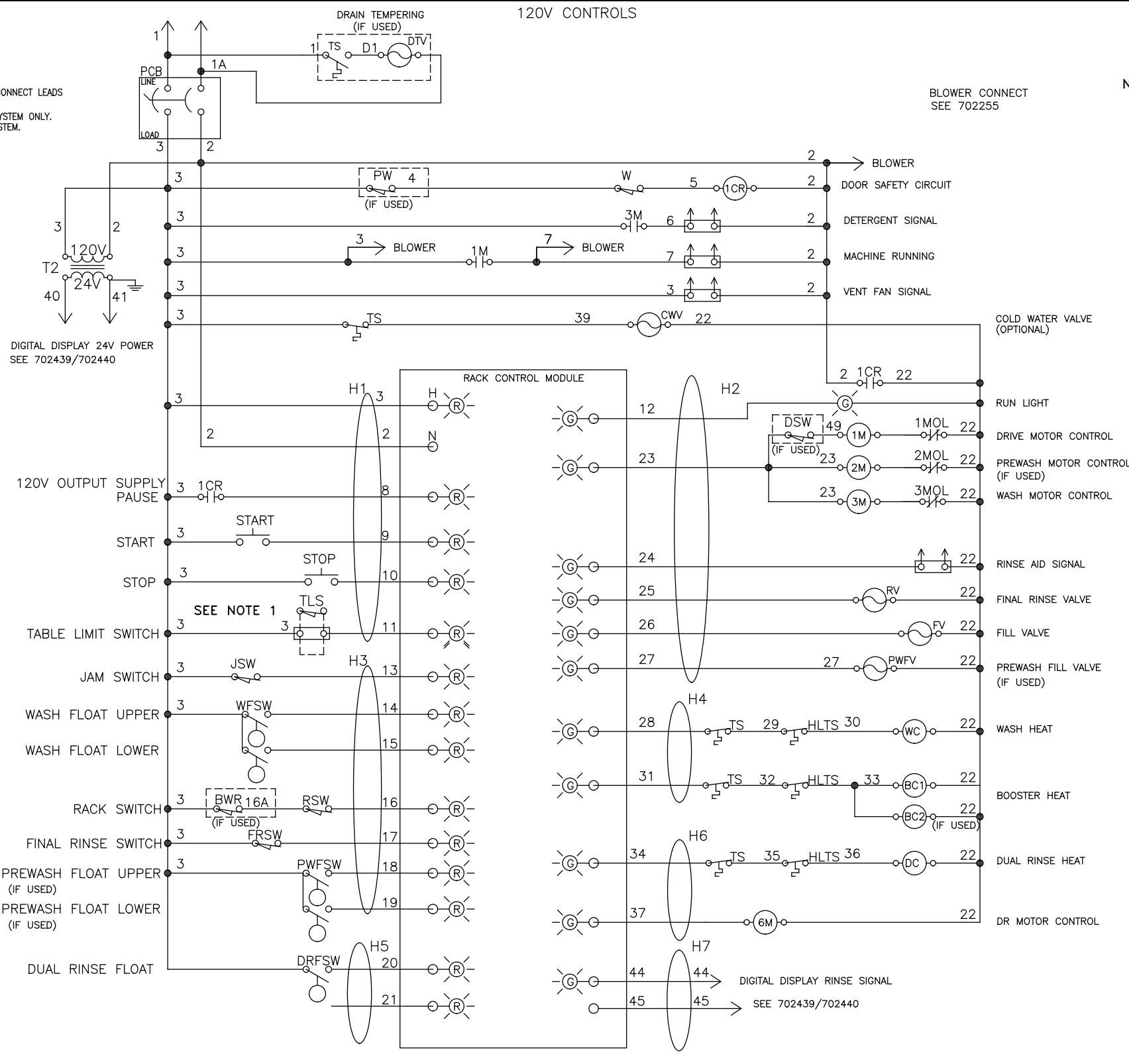
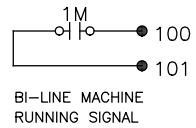
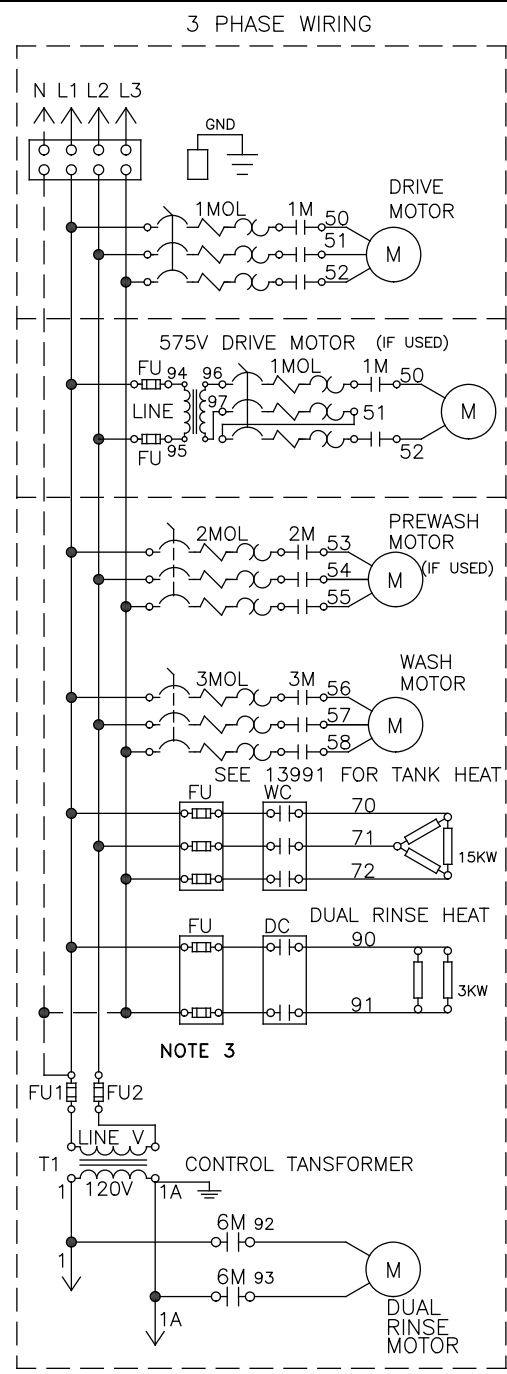

DIAGRAM STATE
POWER OFF
DOORS CLOSED
TANKS EMPTY



BLOWER CONNECT SEE 702255

NOTE 2



E44DR/E44DRPW RACK MACHINE
ELECTRIC OR STEAM HEAT
B 702385-1 REV. B

CUSTOMER TO SUPPLY RATED VOLTAGE/PHASE/HZ, AS SPECIFIED PER ORDER, TO DISCONNECT SWITCH. ALL POWER SUPPLIED TO EACH CONNECTION POINT MUST COMPLY WITH ALL LOCAL ELECTRIC CODES.			
DR. BY	J.MCALLISTER	SCALE	NONE
DATE	11JUL12	SHEET	1 OF 1

REV.	DESCRIPTION	DATE	BY
A	ADDED BILINE MACHINE RUNNING SIGNAL	19JAN14	JAM
B	ADDED DRIVE SWITCH FOR FRONT FEED MACHINES	03MAR14	JAM

REV.	DESCRIPTION	DATE	BY

Champion
The Dishwashing Machine Specialists

MODELS COVERED BY THIS DRAWING	
E44DR	E54DR
E66DRPW	E76DRPW
E70DRFFPW	80FFDRPW

NOTES:

1. WHEN TABLE LIMIT SWITCH IS USED REMOVE JUMPER AND CONNECT LEADS BETWEEN WIRES 3 AND 11 ON TERMINAL BLOCK IN PANEL.
2. WHEN THE MACHINE HAS A SIDeloader DRIVE MOTOR CONTACTOR IS CONNECTED TO WIRE #8.
3. 4TH POLE USED FOR NEUTRAL ON THREE PHASE 5 WIRE SYSTEM ONLY.

1CR	DOOR SAFETY RELAY
1M	DRIVE MOTOR CONTACTOR
1MOL	DRIVE MOTOR OVERLOAD
2CR	WASH HEAT RELAY
2M	PREWASH MOTOR CONTACTOR
2MOL	PREWASH MOTOR OVERLOAD
3M	WASH MOTOR CONTACTOR
3MOL	WASH MOTOR OVERLOAD
6M	DR MOTOR RELAY
BC-	BOOSTER CONTACTOR/STEAM VALVE
CWV	COLD WATER VALVE
DTV	DRAIN TEMPERING VALVE
DC	DUAL RINSE HEAT CONTACTOR
FRSW	FINAL RINSE SWITCH
FU	FUSE/FUSE BLOCK
FV	FILL VALVE
GB1	GAS BOOSTER RELAY
HCP	HEAT CIRCULATING PUMP
HLTS	HIGH LIMIT THERMOSTAT
JSW	JAM SWITCH
PCB	POWER SWITCH/CIRCUIT BREAKER
PW	PREWASH DOOR SWITCH
PWFV	PREWASH FILL VALVE
PWFSW	PREWASH TANK FLOAT SWITCH
RC	RINSE HEAT CONTACTOR
RSW	RACK SWITCH
RV	RINSE VALVE
T1	CONTROL TRANSFORMER
TLS	TABLE LIMIT SWITCH
TS	THERMOSTAT
W	WASH DOOR SWITCH
WC	WASH HEAT CONTACTOR/STEAM VALVE
WFSW	WASH TANK FLOAT SWITCH

HARNESS ASSEMBLIES

- H1 - 6 PIN ALL MODELS
- H2 - 6 PIN ALL MODELS
- H3 - 8 PIN ALL MODELS
- H4 - 2 PIN ALL MODELS
- H5 - 2 PIN ALL MODELS
- H6 - 2 PIN ALL MODELS
- H7 - 2 PIN ALL MODELS

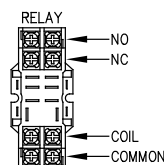
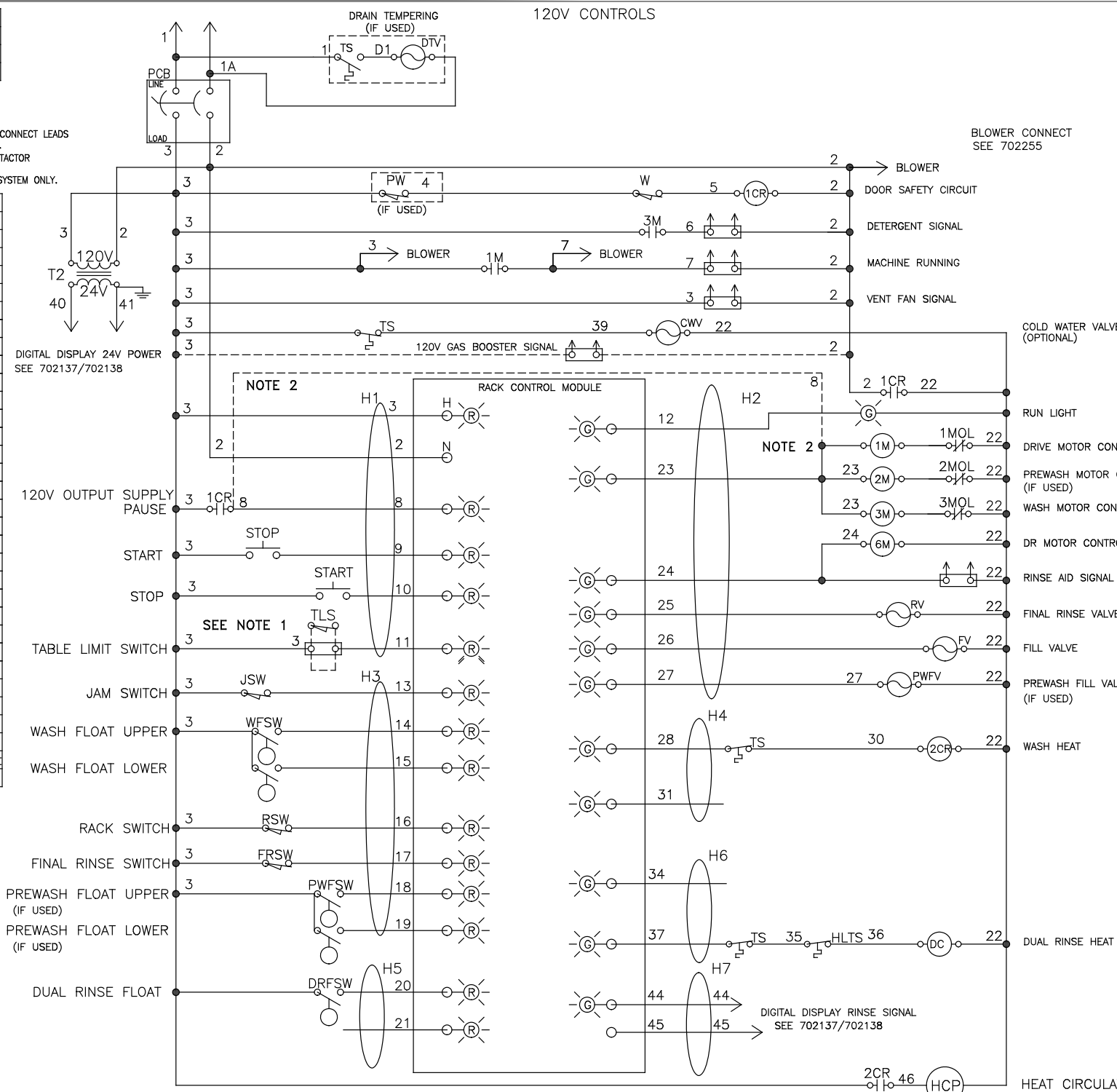

DIAGRAM STATE
POWER OFF
DOORS CLOSED
TANKS EMPTY

CUSTOMER TO SUPPLY RATED VOLTAGE/PHASE/Hz. AS SPECIFIED PER ORDER TO DISCONNECT SWITCH. ALL POWER SUPPLIED TO EACH CONNECTION POINT MUST COMPLY WITH ALL LOCAL ELECTRIC CODES.			
DR.BY	J.MCALLISTER	SCALE	NONE
DATE	30JAN13	SHEET	1 OF 1



REV.	DESCRIPTION	DATE	BY
A	REVISION FOR RELEASE TO PRODUCTION	30JAN13	JAM

REV.	DESCRIPTION	DATE	BY

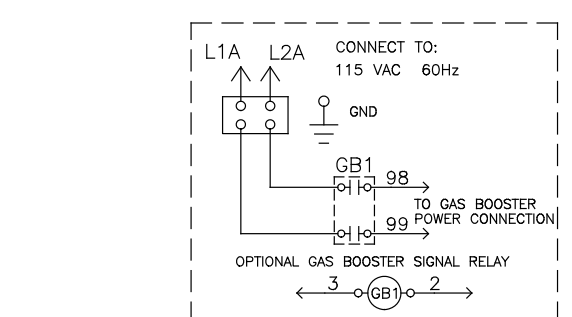
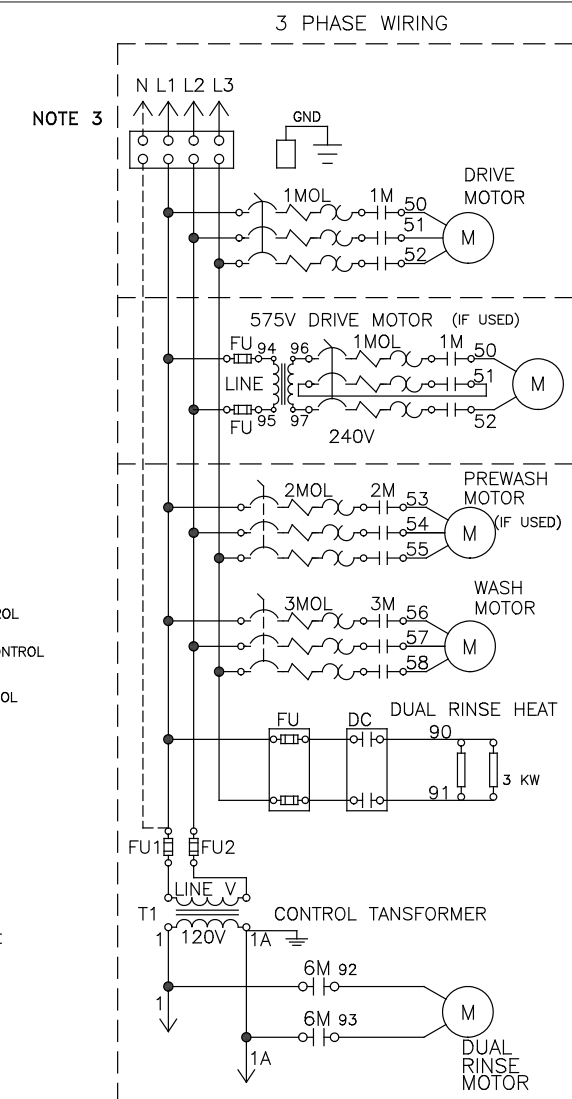

Champion
The Dishwashing Machine Specialists

E44DR/E44DRPW RACK MACHINE
HOT WATER HEAT
B702385-2 REV. 0

MODELS COVERED BY THIS DRAWING	
E64	E84
E86PW	106PW
90FFPW	120HDPW

NOTES:

- WHEN TABLE LIMIT SWITCH IS USED REMOVE JUMPER AND CONNECT LEADS BETWEEN WIRES 3 AND 11 ON TERMINAL BLOCK IN PANEL.
- 4TH POLE USED FOR NEUTRAL ON THREE PHASE 5 WIRE SYSTEM ONLY.

1CR	DOOR SAFETY RELAY
1M	DRIVE MOTOR CONTACTOR
1MOL	DRIVE MOTOR OVERLOAD
2M	PREWASH MOTOR CONTACTOR
2MOL	PREWASH MOTOR OVERLOAD
3M	WASH MOTOR CONTACTOR
3MOL	WASH MOTOR OVERLOAD
4M	RINSE MOTOR CONTACTOR
4MOL	RINSE MOTOR OVERLOAD
BC-	BOOSTER CONTACTOR/STEAM VALVE
BWR	BLOWER
CDS	CONVEYOR DWELL SWITCH
DSW	DRIVE SWITCH (FRONT FEED ONLY)
DTV	DRAIN TEMPERING VALVE
FRSW	FINAL RINSE SWITCH
FU	FUSE/FUSE BLOCK
FV	FILL VALVE
HLTS	HIGH LIMIT THERMOSTAT
JSW	JAM SWITCH
PCB	POWER SWITCH/CIRCUIT BREAKER
PW	PREWASH DOOR SWITCH
PWFV	PREWASH FILL VALVE
PWFSW	PREWASH TANK FLOAT SWITCH
R	RINSE DOOR SWITCH
RC	RINSE HEAT CONTACTOR/STEAM VALVE
RFSW	RINSE FLOAT SWITCH
RSW	RACK SWITCH
RV	RINSE VALVE
T1	CONTROL TRANSFORMER 120 V
T2	CONTROL TRANSFORMER 24 V
TLS	TABLE LIMIT SWITCH
TS	THERMOSTAT
W	WASH DOOR SWITCH
WC	WASH HEAT CONTACTOR/STEAM VALVE
WFSW	WASH TANK FLOAT SWITCH

HARNESS ASSEMBLIES

- H1 - 6 PIN ALL MODELS
- H2 - 6 PIN ALL MODELS
- H3 - 8 PIN ALL MODELS
- H4 - 2 PIN ALL MODELS
- H5 - 2 PIN ALL MODELS
- H6 - 2 PIN ALL MODELS
- H7 - 2 PIN ALL MODELS

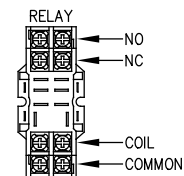
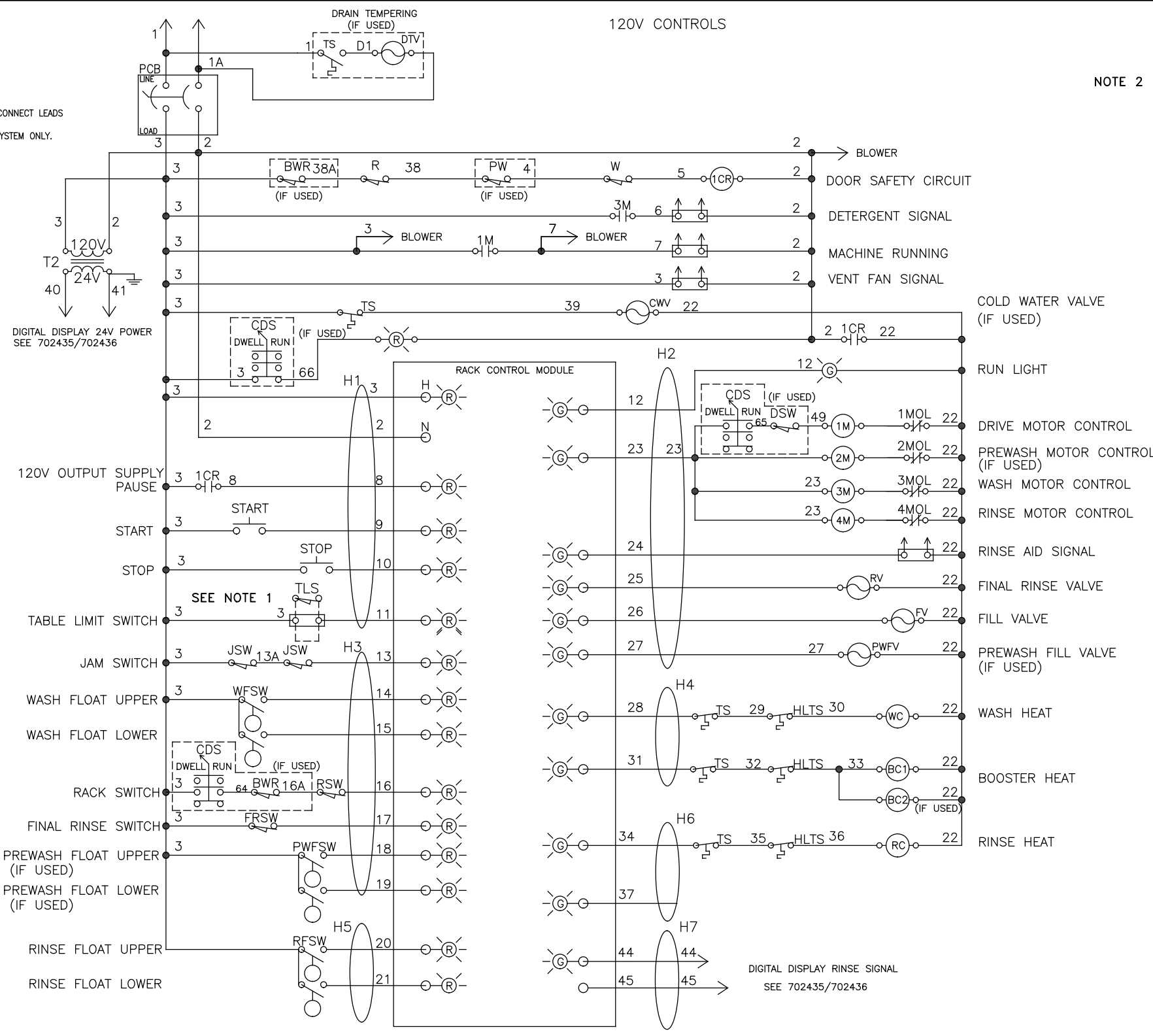

DIAGRAM STATE
POWER OFF
DOORS CLOSED
TANKS EMPTY

CUSTOMER TO SUPPLY RATED VOLTAGE/PHASE/Hz, AS SPECIFIED PER ORDER, TO DISCONNECT SWITCH. ALL POWER SUPPLIED TO EACH CONNECTION POINT MUST COMPLY WITH ALL LOCAL ELECTRIC CODES.		
DR. BY	J.MCALLISTER	SCALE NONE
DATE	27MAR12	SHEET 1 OF 1

REV.	DESCRIPTION	DATE	BY
A	REVISION FOR RELEASE TO PRODUCTION	26SEP12	JAM
B	ADDED DRIVE SWITCH FOR FRONT FEED MACHINES	03MAR14	JAM
C	ADDED DOOR SWITCH AND RACK SWITCH FOR BLOWER	18MAR14	JAM

REV.	DESCRIPTION	DATE	BY
D	ADDED CONVEYOR DWELL SWITCH	24JUN14	JAM
E	ADDED SECOND JAM SWITCH FOR MRA TABLE	13AUG14	JAM



NOTE 2

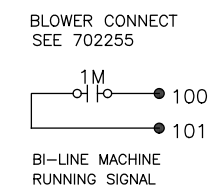
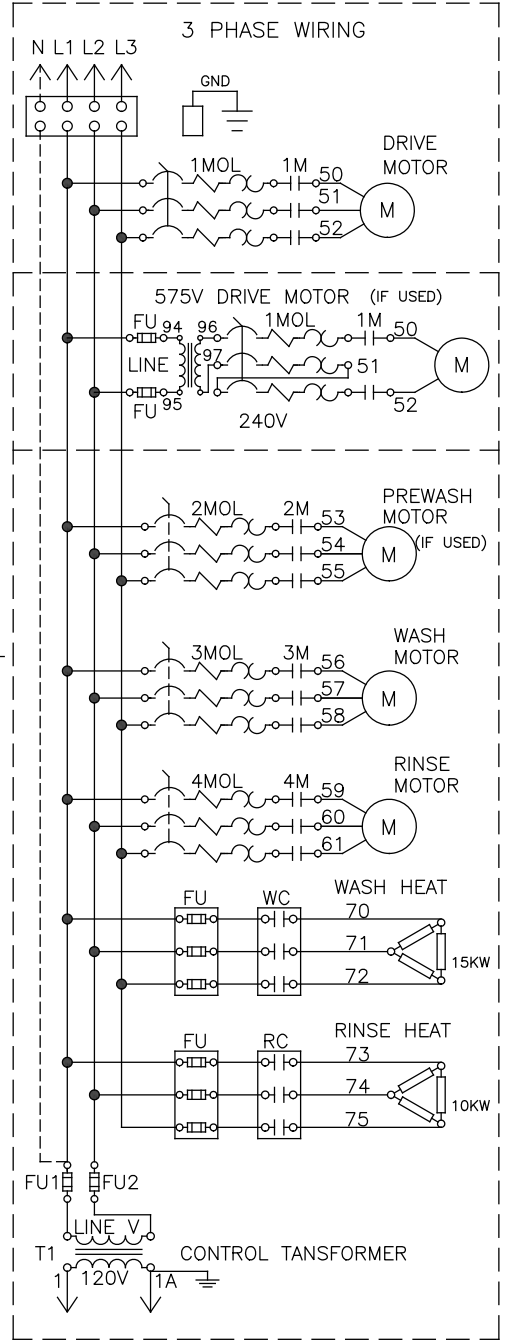

Champion
The Dishwashing Machine Specialists

E64/E64PW RACK MACHINE
STEAM OR ELECTRIC HEAT
B 702376-1 REV. D

MODELS COVERED BY THIS DRAWING	
E64	E84
E86PW	106PW
90FFPW	120HDPW

NOTES:

- WHEN TABLE LIMIT SWITCH IS USED REMOVE JUMPER AND CONNECT LEADS BETWEEN WIRES 3 AND 11 ON TERMINAL BLOCK IN PANEL.
- 4TH POLE USED FOR NEUTRAL ON THREE PHASE 5 WIRE SYSTEM ONLY.

1CR	DOOR SAFETY RELAY
1M	DRIVE MOTOR CONTACTOR
1MOL	DRIVE MOTOR OVERLOAD
2CR	WASH HEAT RELAY
2M	PREWASH MOTOR CONTACTOR
2MOL	PREWASH MOTOR OVERLOAD
3CR	RINSE HEAT RELAY
3M	WASH MOTOR CONTACTOR
3MOL	WASH MOTOR OVERLOAD
4M	RINSE MOTOR CONTACTOR
4MOL	RINSE MOTOR OVERLOAD
BWR	BLOWER
CWV	COLD WATER VALVE
DTV	DRAIN TEMPERING VALVE
FRSW	FINAL RINSE SWITCH
FU	FUSE/FUSE BLOCK
FV	FILL VALVE
GB1	GAS BOOSTER RELAY
HCP	HEAT CIRCULATING PUMP
HLTS	HIGH LIMIT THERMOSTAT
JSW	JAM SWITCH
PCB	POWER SWITCH/CIRCUIT BREAKER
PW	PREWASH DOOR SWITCH
PWV	PREWASH FILL VALVE
PWFSW	PREWASH TANK FLOAT SWITCH
R	RINSE DOOR SWITCH
RC	RINSE HEAT HOT WATER VALVE
RFSW	RINSE FLOAT SWITCH
RSW	RACK SWITCH
RV	RINSE VALVE
T1	CONTROL TRANSFORMER 120 V
T2	CONTROL TRANSFORMER 24 V
TLS	TABLE LIMIT SWITCH
TS	THERMOSTAT
W	WASH DOOR SWITCH
WC	WASH HEAT HOT WATER VALVE
WFSW	WASH TANK FLOAT SWITCH

HARNESS ASSEMBLIES
 H1 - 6 PIN ALL MODELS
 H2 - 6 PIN ALL MODELS
 H3 - 8 PIN ALL MODELS
 H4 - 2 PIN ALL MODELS
 H5 - 2 PIN ALL MODELS
 H6 - 2 PIN ALL MODELS
 H7 - 2 PIN ALL MODELS

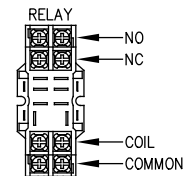

DIAGRAM STATE
 POWER OFF
 DOORS CLOSED
 TANKS EMPTY

CUSTOMER TO SUPPLY RATED VOLTAGE/PHASE/Hz, AS SPECIFIED PER ORDER, TO DISCONNECT SWITCH. ALL POWER SUPPLIED TO EACH CONNECTION POINT MUST COMPLY WITH ALL LOCAL ELECTRIC CODES.
 DR. BY J.MCALLISTER SCALE NONE
 DATE 30JAN13 SHEET 1 OF 1

REV.	DESCRIPTION	DATE	BY
A	REVISION FOR RELEASE TO PRODUCTION	30JAN13	JAM
B	ADDED DOOR SWITCH AND RACK SWITCH FOR BLOWER	18MAR14	JAM

REV.	DESCRIPTION	DATE	BY

Champion
 The Dishwashing Machine Specialists

E64/E64PW RACK MACHINE
 HOT WATER HEAT
B702376-2 REV. B

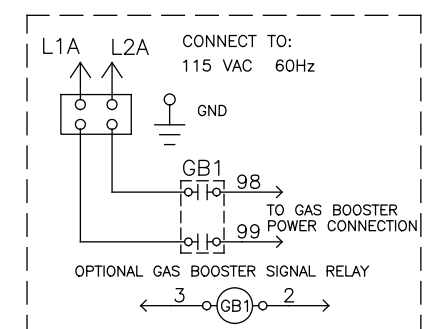
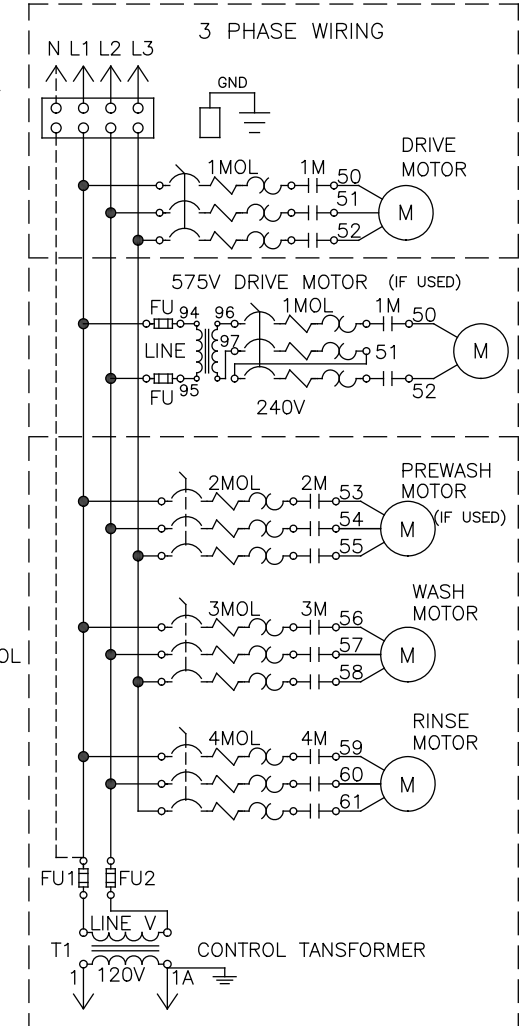
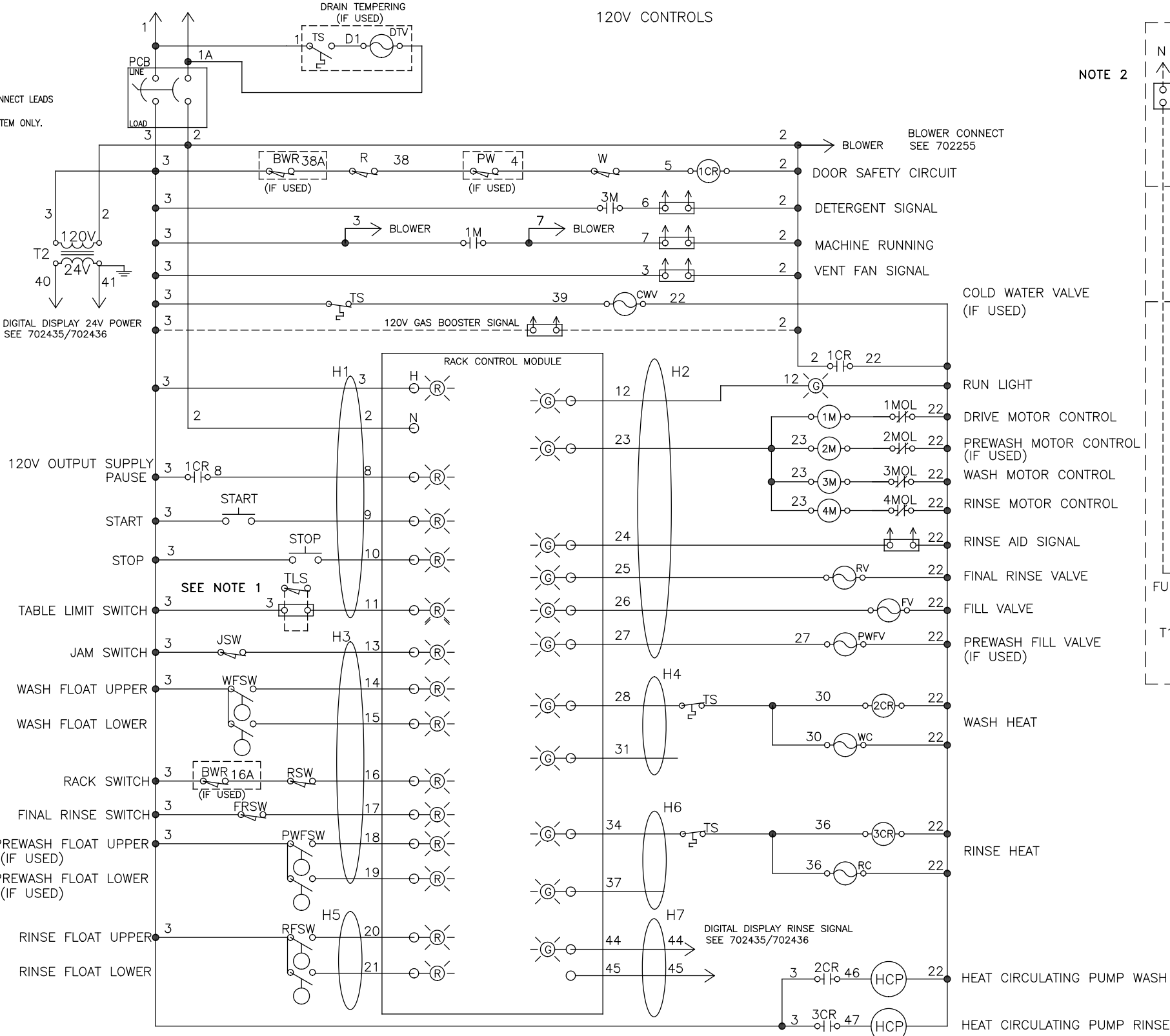

E SERIES RACK MACHINE DOUBLE RINSE BOOSTER HEATER CONNECTIONS

3 PHASE CONNECTION

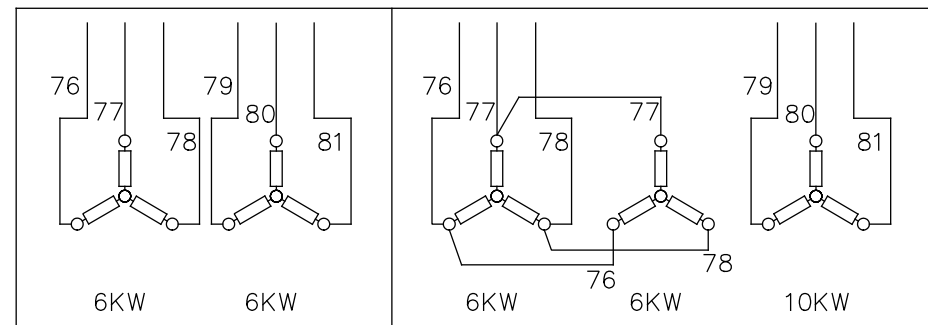
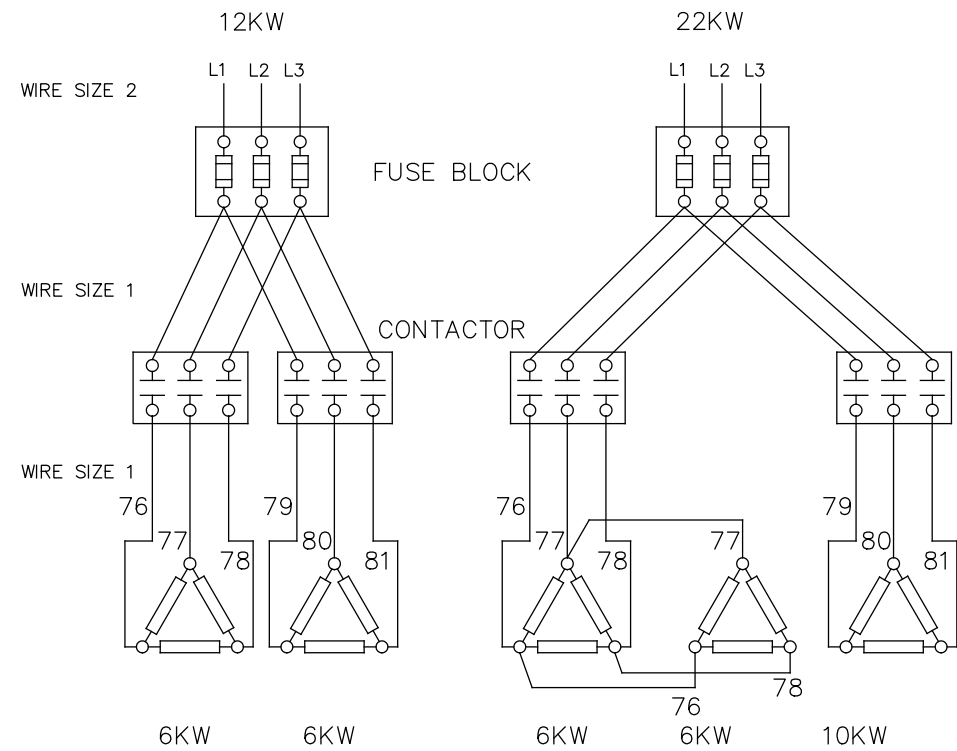

Y CONNECTION 380/415V

1 PHASE CONNECTION

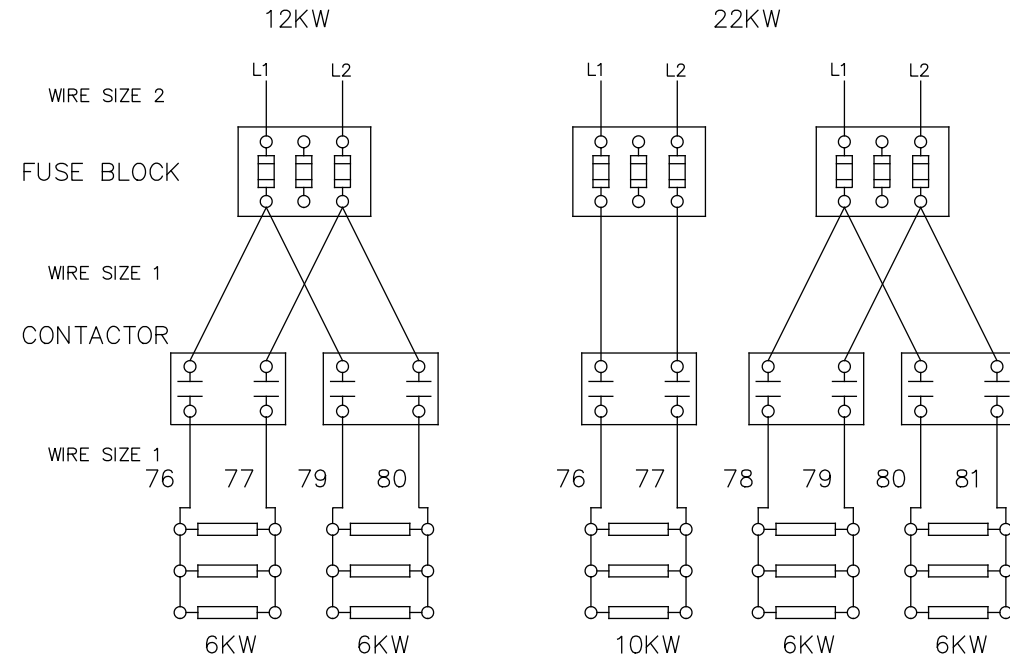

VOLTAGE 200-220V	12KW	22KW
KW/CONTACTOR	6KW	10/12KW
CONTACTOR RATING	60A	60A
FUSE RATING	60A	80A
WIRE SIZE 1	#8	#8
WIRE SIZE 2	#6	#4

VOLTAGE 200-220V	10KW	12KW
KW/CONTACTOR	10KW	6KW
CONTACTOR RATING	60	60A
FUSE RATING	60A	70A
WIRE SIZE 1	#6	#8
WIRE SIZE 2	#6	#6

VOLTAGE 230-240V	12KW	22KW
KW/CONTACTOR	6KW	10/12KW
CONTACTOR RATING	60A	60A
FUSE RATING	45A	80A
WIRE SIZE 1	#8	#8
WIRE SIZE 2	#4	#4

VOLTAGE 230-240V	12KW	22KW
KW/CONTACTOR	6KW	10/12KW
CONTACTOR RATING	60A	60A
FUSE RATING	40A	70A
WIRE SIZE 1	#10	#10
WIRE SIZE 2	#6	#6

VOLTAGE 380V	12KW	22KW
KW/CONTACTOR	6KW	10/12KW
CONTACTOR RATING	60A	60A
FUSE RATING	25A	40A
WIRE SIZE 1	#12	#12
WIRE SIZE 2	#10	#10

VOLTAGE 415V	12KW	22KW
KW/CONTACTOR	6KW	10/12KW
CONTACTOR RATING	60A	60A
FUSE RATING	25A	40A
WIRE SIZE 1	#12	#12
WIRE SIZE 2	#10	#10

VOLTAGE 440V	12KW	22KW
KW/CONTACTOR	6KW	10/12KW
CONTACTOR RATING	60A	60A
FUSE RATING	20A	35A
WIRE SIZE 1	#12	#12
WIRE SIZE 2	#10	#10

VOLTAGE 480V	12KW	22KW
KW/CONTACTOR	6KW	10/12KW
CONTACTOR RATING	60A	60A
FUSE RATING	20A	35A
WIRE SIZE 1	#12	#12
WIRE SIZE 2	#10	#10

VOLTAGE 575V	12KW	22KW
KW/CONTACTOR	6KW	10/12KW
CONTACTOR RATING	60A	60A
FUSE RATING	15A	30A
WIRE SIZE 1	#12	#12
WIRE SIZE 2	#12	#12

PN: 114039 REV D

CUSTOMER TO SUPPLY RATED VOLTAGE/PHASE/HZ, AS SPECIFIED PER ORDER, TO DISCONNECT SWITCH. ALL POWER SUPPLIED TO EACH CONNECTION POINT MUST COMPLY WITH ALL LOCAL ELECTRIC CODES.
 DR. BY J.MCALLISTER SCALE
 DATE 05JAN05 SHEET 1 OF 1

REV.	DESCRIPTION	DATE	BY
A	CHANGED WIRE SIZE FOR 12 KW BOOSTER	08MAR05	JAM
B	CHANGED 12 KW HEATER TO TWO 6KW HEATERS	16MAY05	JAM
C	ADDED 22 KW SINGLE PHASE HEATERS	27JUN09	JAM

REV.	DESCRIPTION	DATE	BY
D	CHANGED 240V 22KW BSTR FUSE SIZE 70 AMPS TO MATCH BILLO	08NOV12	JAM
E	ADDED HEATER REQUIREMENTS FOR 440V THREE PHASE	27OCT14	JAM

Champion
 The Dishwashing Machine Specialists

BOOSTER TANK HEAT FOR DOUBLE RINSE
 E SERIES RACK CONVEYOR MACHINES
 B 701945 REV. E



E SERIES RACK MACHINE INTERNAL BOOSTER HEATER WIRING

24 KW BOOSTER HEATER

VOLTAGE 208V DELTA		
TOTAL KW	24KW	
KW/CONTACTOR	12KW	12KW
CONTACTOR #	1	2
CONTACTOR RATING	60A	60A
WIRE SIZE	8	8
FUSE RATING	45A	45A
VOLTAGE 240V DELTA		
TOTAL KW	24KW	
KW/CONTACTOR	12KW	12KW
CONTACTOR #	1	2
CONTACTOR RATING	60A	60A
WIRE SIZE	10	10
FUSE RATING	35A	35A
VOLTAGE 380V WYE (NOT SHOWN)		
TOTAL KW	24KW	
KW/CONTACTOR	12KW	12KW
CONTACTOR #	1	2
CONTACTOR RATING	60A	60A
WIRE SIZE	12	12
FUSE RATING	25A	25A
VOLTAGE 415V WYE (NOT SHOWN)		
TOTAL KW	24KW	
KW/CONTACTOR	12KW	12KW
CONTACTOR #	1	2
CONTACTOR RATING	60A	60A
WIRE SIZE	12	12
FUSE RATING	25A	25A
VOLTAGE 480V DELTA		
TOTAL KW	24KW	
KW/CONTACTOR	12KW	12KW
CONTACTOR #	1	2
CONTACTOR RATING	60A	60A
WIRE SIZE	12	12
FUSE RATING	20A	20A
VOLTAGE 575V DELTA		
TOTAL KW	24KW	
KW/CONTACTOR	12KW	12KW
CONTACTOR #	1	2
CONTACTOR RATING	60A	60A
WIRE SIZE	12	12
FUSE RATING	15A	15A

24 KW BOOSTER HEATER

VOLTAGE 208V SINGLE PHASE		
TOTAL KW	24KW	
KW/CONTACTOR	12KW	12KW
CONTACTOR #	1	2
CONTACTOR RATING	75A	75A
WIRE SIZE	6	6
FUSE RATING	70A	70A
VOLTAGE 240V SINGLE PHASE		
TOTAL KW	24KW	
KW/CONTACTOR	12KW	12KW
CONTACTOR #	1	2
CONTACTOR RATING	60A	60A
WIRE SIZE	6	6
FUSE RATING	60A	60A

15 KW BOOSTER HEATER

VOLTAGE 208V DELTA		
TOTAL KW	15KW	15KW
KW/CONTACTOR	15KW	15KW
CONTACTOR #	1	1
CONTACTOR RATING	60A	75A
WIRE SIZE 1	10	8
WIRE SIZE 2	8	4
FUSE RATING	50A	90A
VOLTAGE 240V DELTA		
TOTAL KW	15KW	15KW
KW/CONTACTOR	15KW	15KW
CONTACTOR #	1	1
CONTACTOR RATING	60A	75A
WIRE SIZE 1	10	8
WIRE SIZE 2	8	4
FUSE RATING	45A	80A
VOLTAGE 380V WYE (NOT SHOWN)		
TOTAL KW	15KW	
KW/CONTACTOR	15KW	
CONTACTOR #	1	
CONTACTOR RATING	60A	
WIRE SIZE 1	12	
WIRE SIZE 2	10	
FUSE RATING	30A	
VOLTAGE 415V WYE (NOT SHOWN)		
TOTAL KW	15KW	
KW/CONTACTOR	15KW	
CONTACTOR #	1	
CONTACTOR RATING	60A	
WIRE SIZE 1	12	
WIRE SIZE 2	10	
FUSE RATING	30A	
VOLTAGE 480V DELTA		
TOTAL KW	15KW	
KW/CONTACTOR	15KW	
CONTACTOR #	1	
CONTACTOR RATING	60A	
WIRE SIZE	12	
FUSE RATING	25A	
VOLTAGE 575V DELTA		
TOTAL KW	15KW	
KW/CONTACTOR	15KW	
CONTACTOR #	1	
CONTACTOR RATING	60A	
WIRE SIZE	12	
FUSE RATING	20A	

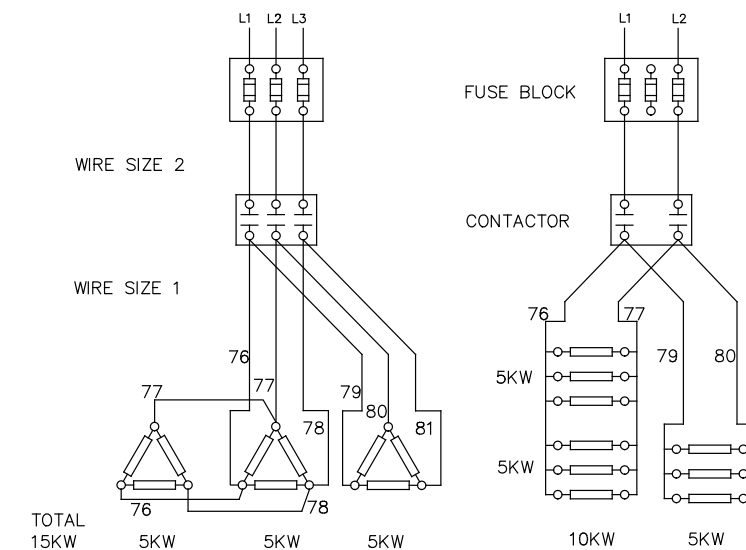
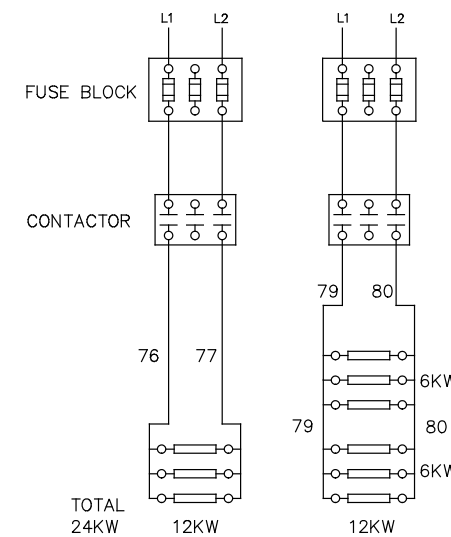
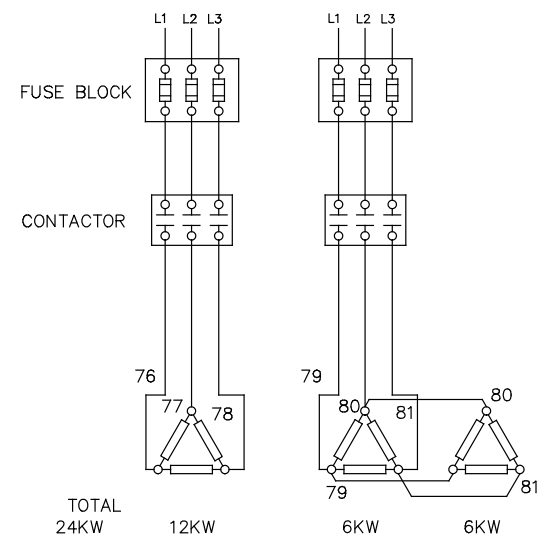

PN: 114038 REV C

CUSTOMER TO SUPPLY RATED VOLTAGE/PHASE/Hz, AS SPECIFIED PER ORDER TO DISCONNECT SWITCH. ALL POWER SUPPLIED TO EACH CONNECTION POINT MUST COMPLY WITH ALL LOCAL ELECTRIC CODES.			
DR. BY	J.MCALLISTER	SCALE	NONE
DATE	5NOV04	SHEET	1 OF 1

REV.	DESCRIPTION	DATE	BY
A	CHANGE HEATER CONFIGURATION	23MAR06	JAM
B	MODIFIED HEATER CONNECTIONS FOR THIRD HEATER	10MAY07	JAM

REV.	DESCRIPTION	DATE	BY

Champion
The Dishwashing Machine Specialists

INTERNAL BOOSTER HEAT E SERIES RACK CONVEYOR MACHINES		
B	701914	REV. B

**

E RACK 30KW HEAT RECOVERY BOOSTER HEATER

3 PHASE CONNECTION

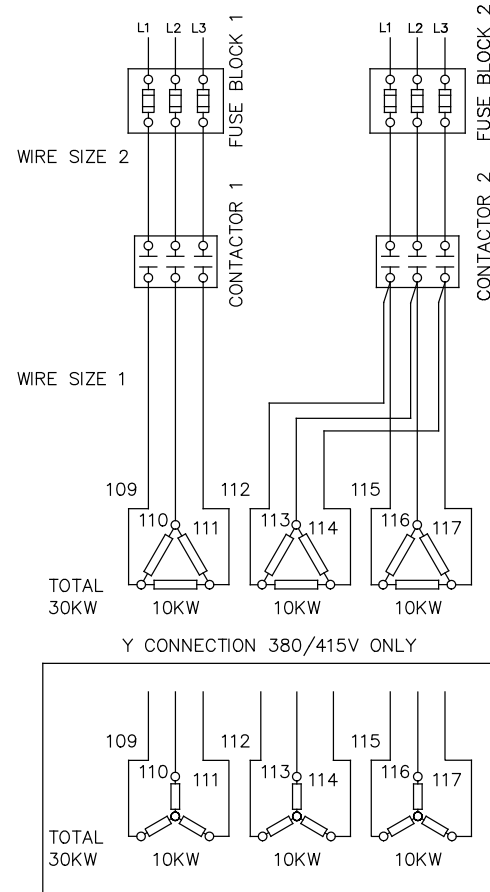

1 PHASE CONNECTION

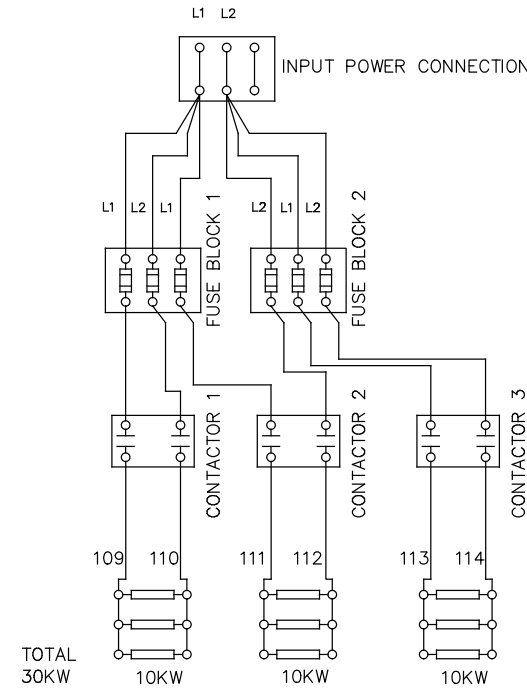

CANISTER 1	KW/CANISTER	30KW
VOLTAGE	208V	
KW/CONTACTOR	10KW	20KW
CONTACTOR #	1	2
CONTACTOR RATING	60A	60A
FUSE BLOCK #	1	2
FUSE RATING	35A	60A
WIRE SIZE 1	#10	#10
WIRE SIZE 2	#10	#6

CANISTER 1	KW/CANISTER	30KW
VOLTAGE	240V	
KW/CONTACTOR	10KW	20KW
CONTACTOR #	1	2
CONTACTOR RATING	60A	60A
FUSE BLOCK #	1	2
FUSE RATING	30A	60A
WIRE SIZE 1	#10	#10
WIRE SIZE 2	#10	#8

CANISTER 1	KW/CANISTER	30KW
VOLTAGE	380V	
KW/CONTACTOR	10KW	20KW
CONTACTOR #	1	2
CONTACTOR RATING	60A	60A
FUSE BLOCK #	1	3
FUSE RATING	20A	45A
WIRE SIZE 1	#12	#12
WIRE SIZE 2	#12	#10

CANISTER 1	KW/CANISTER	30KW
VOLTAGE	415V	
KW/CONTACTOR	10KW	20KW
CONTACTOR #	1	3
CONTACTOR RATING	60A	60A
FUSE BLOCK #	1	3
FUSE RATING	20A	35A
WIRE SIZE 1	#12	#12
WIRE SIZE 2	#12	#10

CANISTER 1	KW/CANISTER	30KW
VOLTAGE	480V	
KW/CONTACTOR	10KW	20KW
CONTACTOR #	1	3
CONTACTOR RATING	60A	60A
FUSE BLOCK #	1	2
FUSE RATING	15A	30A
WIRE SIZE 1	#12	#12
WIRE SIZE 2	#12	#10

CANISTER 1	KW/CANISTER	30KW
VOLTAGE	575V	
KW/CONTACTOR	10KW	20KW
CONTACTOR #	1	3
CONTACTOR RATING	60A	60A
FUSE BLOCK #	1	3
FUSE RATING	15A	25A
WIRE SIZE 1	#12	#12
WIRE SIZE 2	#12	#12

CANISTER 1	KW/CANISTER	30KW	
VOLTAGE	200-220V		
KW/CONTACTOR	10KW	10KW	10KW
CONTACTOR #	2	3	3
CONTACTOR RATING	60A	60A	60A
FUSE BLOCK #	1	1&2	2
FUSE RATING	60A	60A	60A
WIRE SIZE	#6	#6	#6

CANISTER 1	KW/CANISTER	30KW	
VOLTAGE	230-240V		
KW/CONTACTOR	10KW	10KW	10KW
CONTACTOR #	1	2	3
CONTACTOR RATING	60A	60A	60A
FUSE BLOCK #	1	1&2	2
FUSE RATING	60A	50A	50A
WIRE SIZE	#6	#8	#8

PN: 702370

CUSTOMER TO SUPPLY RATED VOLTAGE/PHASE/Hz, AS SPECIFIED PER ORDER, TO DISCONNECT SWITCH. ALL POWER SUPPLIED TO EACH CONNECTION POINT MUST COMPLY WITH ALL LOCAL ELECTRIC CODES.

DR. BY J.MCALLISTER SCALE

DATE 30NOV11 SHEET 1 OF 1

REV.	DESCRIPTION	DATE	BY

REV.	DESCRIPTION	DATE	BY

Champion
The Dishwashing Machine Specialists

E RACK 30KW BOOSTER FOR HEAT RECOVERY

B 702370 REV.

✱✱

E44/54DR RACK MACHINE THERMISTOR WIRING



MACHINE CONNECTIONS

CONTROL CABINET CONNECTIONS

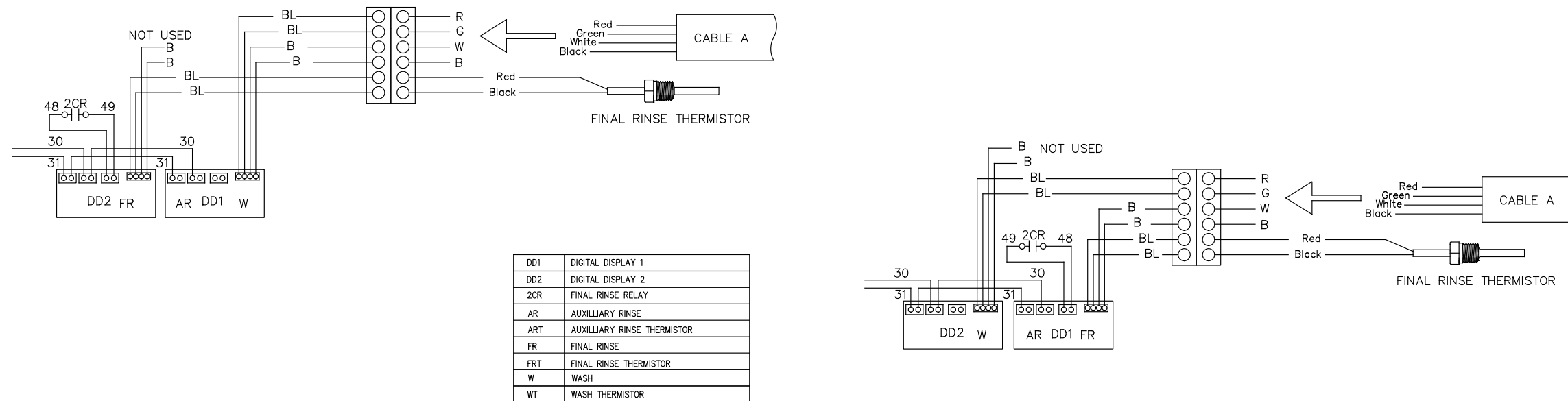

CUSTOMER TO SUPPLY RATED VOLTAGE/PHASE/Hz, AS SPECIFIED PER ORDER TO DISCONNECT SWITCH. ALL POWER SUPPLIED TO EACH CONNECTION POINT MUST COMPLY WITH ALL LOCAL ELECTRIC CODES.

DR. BY	J.MCALLISTER	SCALE	NONE
DATE	08APR09	SHEET	1 OF 1

REV.	DESCRIPTION	DATE	BY
A	CHANGED LAYOUT TO ACCOMODATE LABELS	4/7/11	ML

Champion
The Dishwashing Machine Specialists

E44/54DR RACK MACHINE THERMISTOR WIRING DIAGRAM
B 702137 REV. A

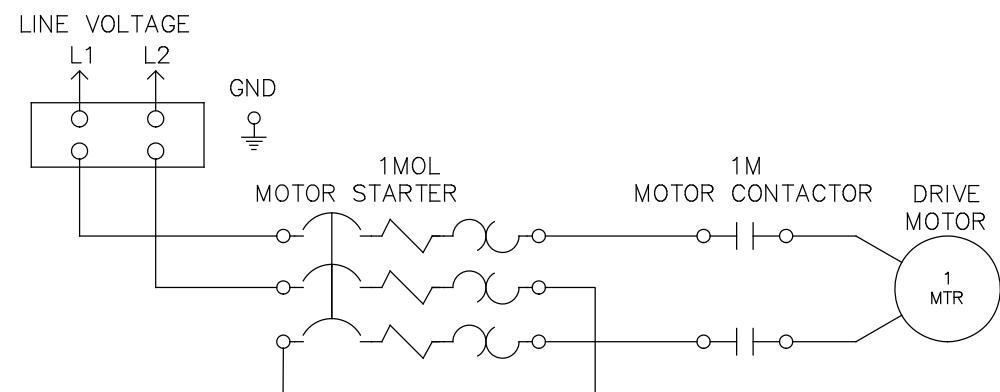

DIGITAL DISPLAY RACK MACHINE
MRA WIRING DIAGRAM

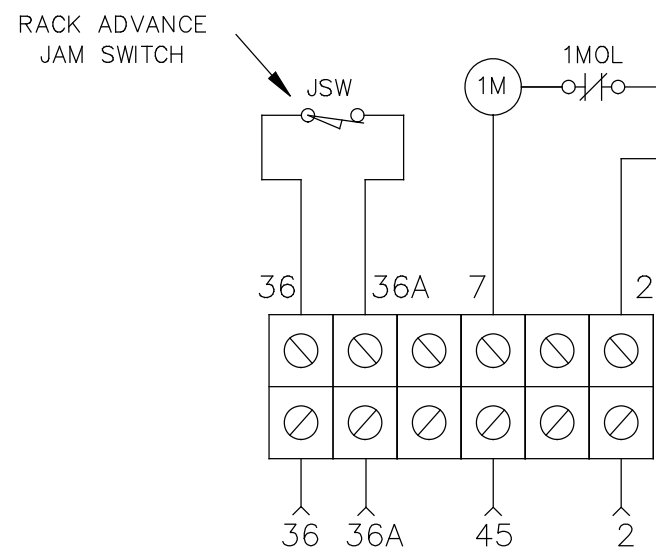

TO JUNCTION BOX UNDER DISH MACHINE

CUSTOMER TO SUPPLY RATED VOLTAGE/PHASE/Hz,
AS SPECIFIED PER ORDER, TO DISCONNECT SWITCH.
ALL POWER SUPPLIED TO EACH CONNECTION POINT
MUST COMPLY WITH ALL LOCAL ELECTRIC CODES.

DR. BY J. MCALLISTER SCALE

DATE 6FEB12 SHEET 1 OF 1

REV.	DESCRIPTION	DATE	BY

Champion

The Dishwashing Machine Specialists

90/180 DEGREE
RACK ADVANCE E SERIES

A 702375 REV. 0

Circuit Board Diagnostics

Solid State Circuit Board P/N 114756

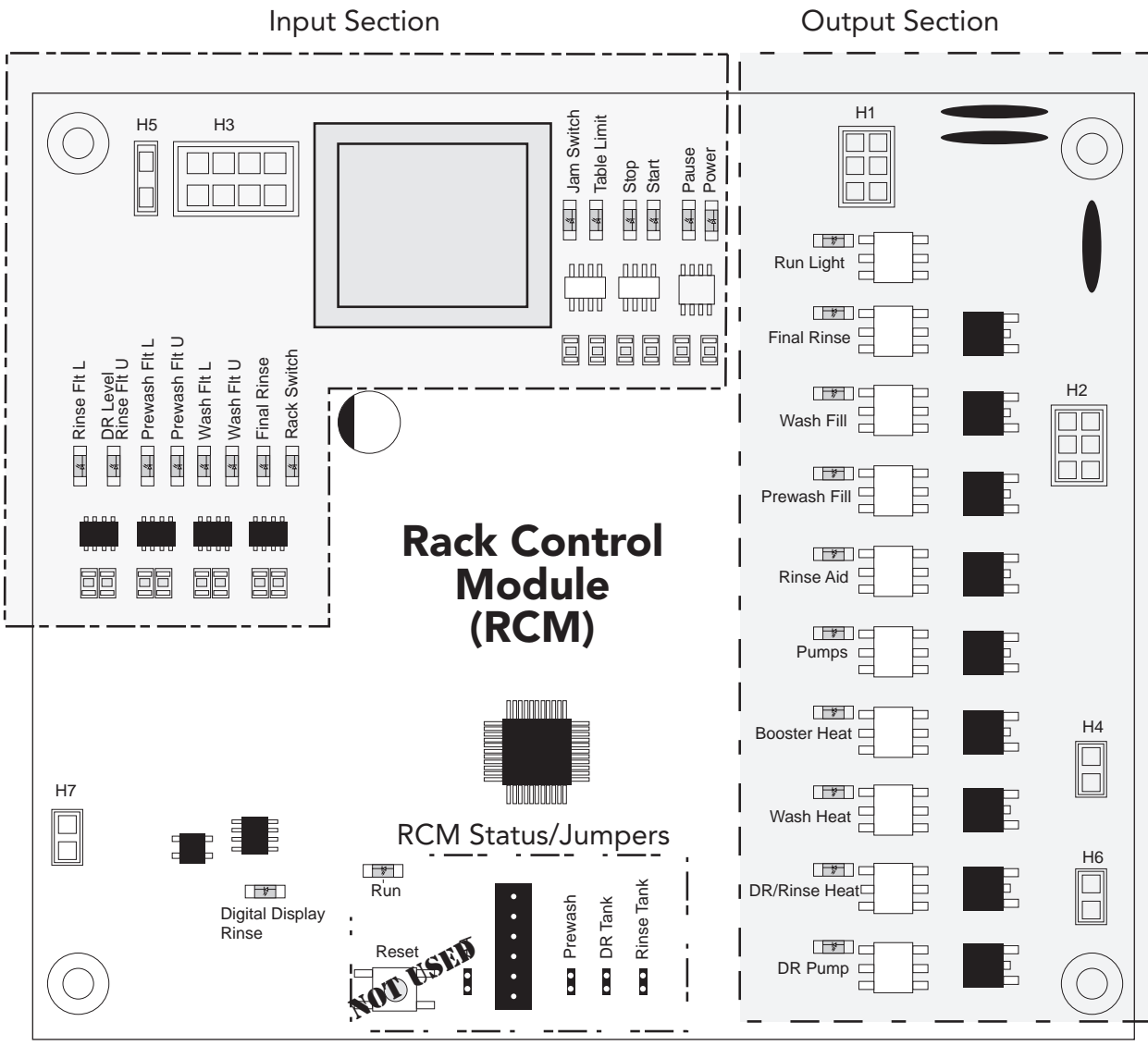

! VERY IMPORTANT !

Improper jumper settings will cause erratic machine operation.
 Make sure the jumpers are set correctly.

MACHINE TYPE	JUMPER SETTINGS			Prewash ●●	DR Tank ●●	Rinse Tank ●●
	PREWASH	DR TANK	RINSE TANK			
Single tank DR w/o PW	OPEN	CLOSED	OPEN			
Single tank DR w/PW	CLOSED	CLOSED	OPEN			
Two tank w/o PW	OPEN	OPEN	CLOSED			
Two tank w/PW	CLOSED	OPEN	CLOSED			

Jumper Settings

The photos at right show the four possible jumper settings for the control module operation.

SINGLE TANK MACHINES W/DUAL RINSE (DR)

Prewash Jumper Open
DR Tank Jumper Closed
Rinse Tank Open



SINGLE TANK MACHINES W/DUAL RINSE (DR) and PREWASH

Prewash Jumper Closed
DR Tank Jumper Closed
Rinse Tank Open

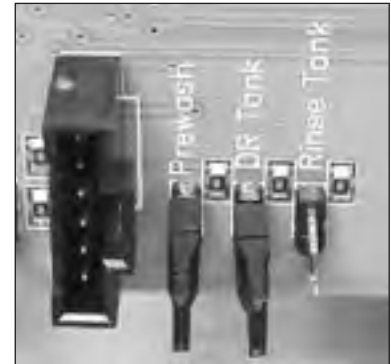

TWO TANK MACHINES WITHOUT PREWASH

Prewash Jumper Open
DR Tank Jumper Open
Rinse Tank Closed

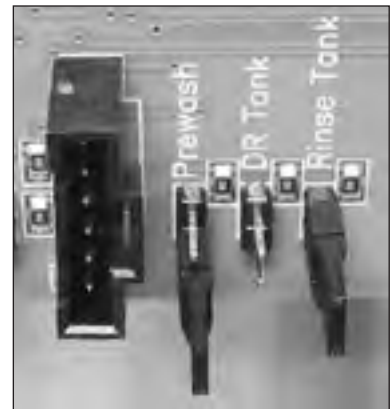

TWO TANK MACHINES W/PREWASH

Prewash Jumper Closed
DR Tank Jumper Open
Rinse Tank Closed



Circuit Board Diagnostics

The following pages illustrate the operational states of the circuit board during the operation of the various dishwasher models.

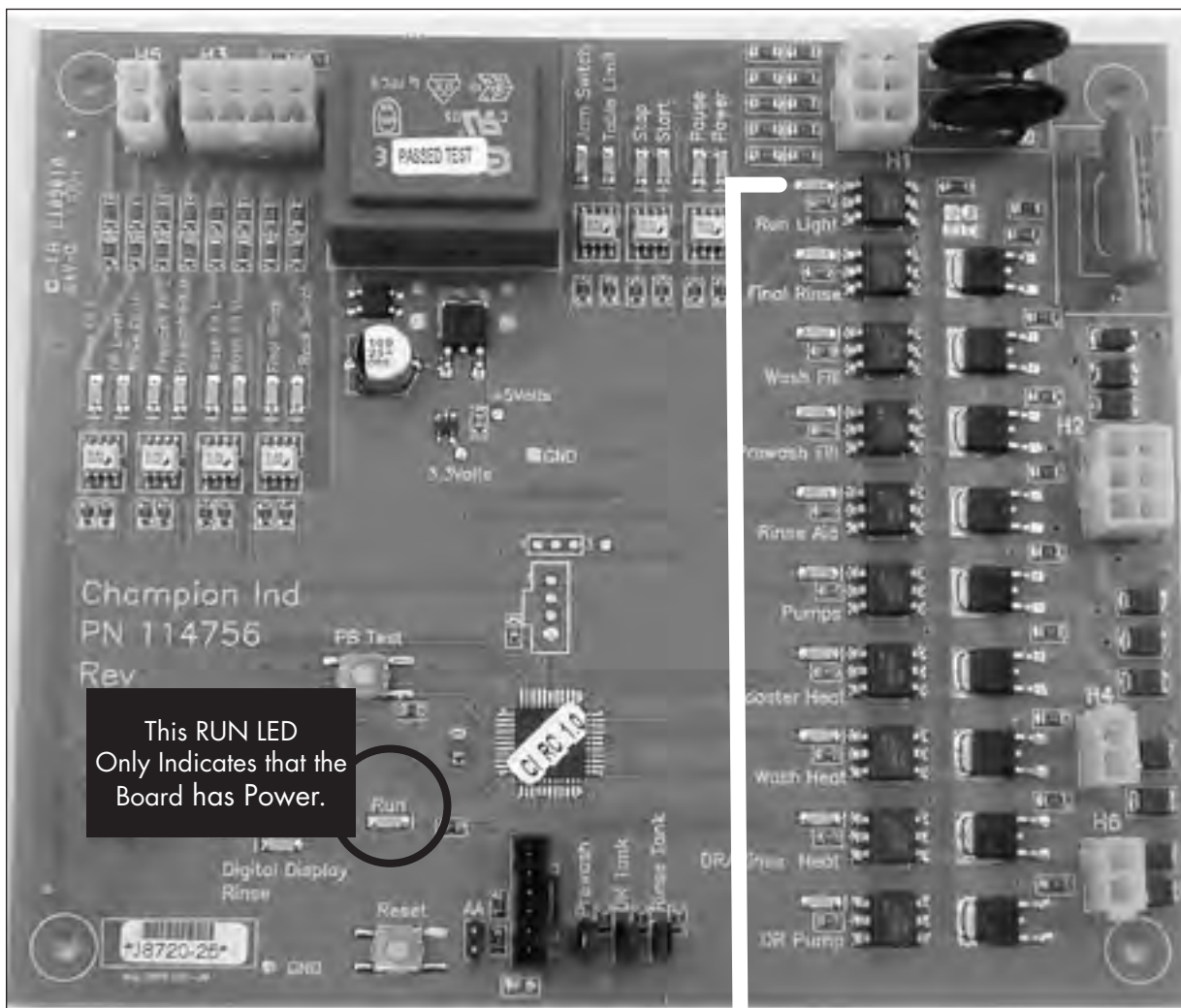

All Models Current State:

1. Main Power is on.
2. Dishwasher power switch is off.
3. All LED's off.

NOTE:

A flashing Run Light at any time indicates that the machine filled for more than 20 minutes. Check the machine drains and fill circuits. Correct the situation then turn the dishwasher power switch off and back on. Remove any dish racks in the machine for reprocessing and resume normal operation.

Current State 1:

**Dishwasher power switch is on.
Machine filling for first time.**

1. Power and Pause LEDs are on.
2. Drive Jam Switch is closed (NC) LED is on.
3. Table Limit Switch is closed (NC) LED is on.
4. Final Rinse Trip Switch is closed (NC) LED is on.
(no dish rack is present)
5. Rack Trip Switch is closed (NC) LED is on.
(no dish rack is present)
The rack switch starts the pumps and drive.
6. For Single Tank w/DR, no Prewash:
Final Rinse and wash fill LEDs are on.
Machine fills through final rinse and wash fill valve.
.....
For Single Tank w/DR and Prewash:
Final Rinse, wash and prewash LEDs are on.
.....
For Two Tank without Prewash:
Final Rinse, wash fill LEDs are on. Machine fills through final rinse, and wash fill valves.
.....
For Two Tank with Prewash:
Final Rinse, wash fill and prewash fill LEDs are on.
Machine fills through final rinse, wash and prewash fill valves.
7. The RUN LED only indicates that the circuit board is energized. It does not indicate that the machine is running.

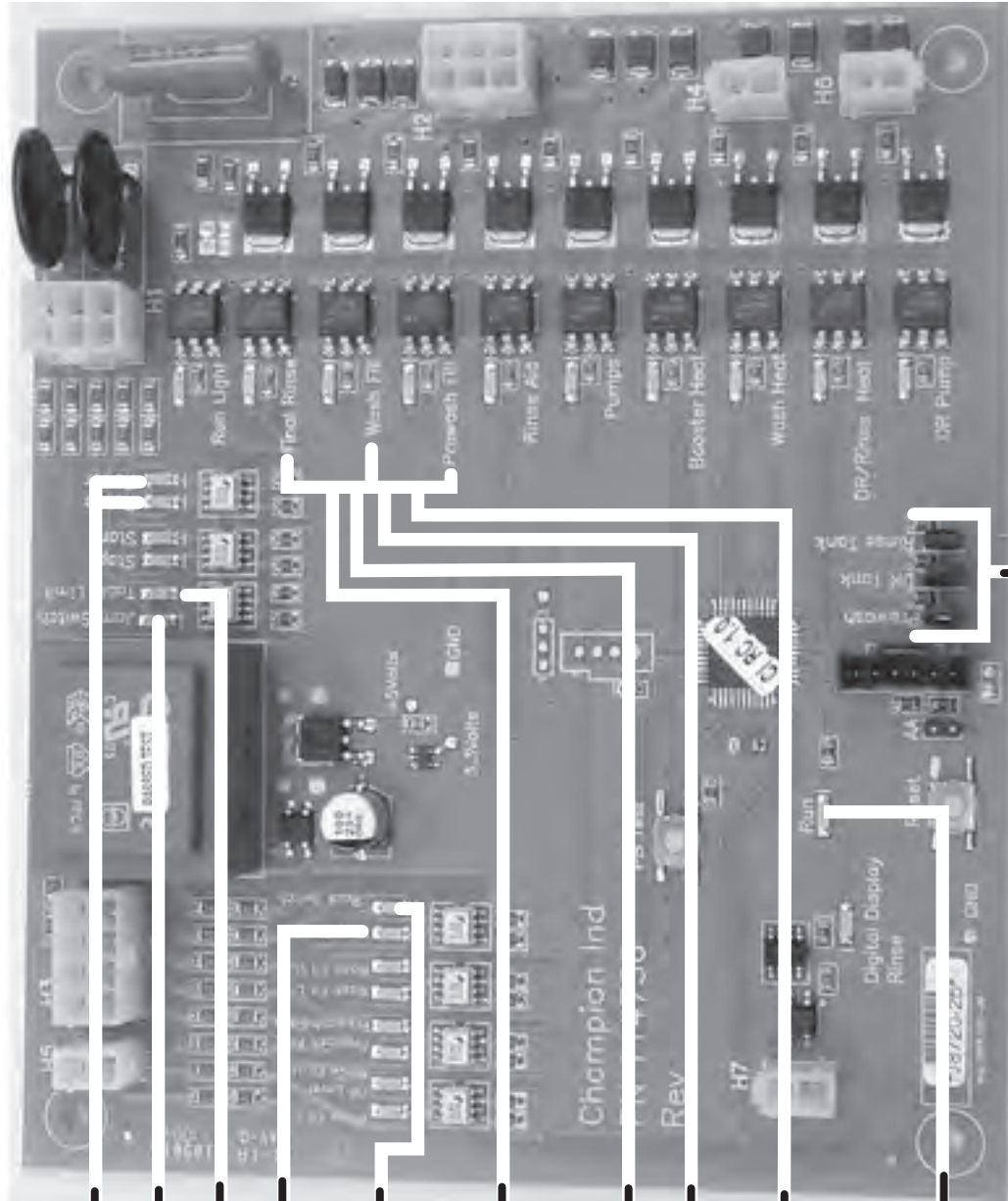

Note:

Jumper settings must be set for the machine model. Refer to page 157 for all possible machine jumper configurations.

**Current State 1 (continued):
Dishwasher power switch is on.
Machine continues to fill.**

1. Power and Pause LEDs are on _____
2. Drive Jam Switch is closed (NC) LED is on. _____
3. Table Limit Switch is closed (NC) LED is on. _____
4. Final Rinse Trip Switch is closed (NC) LED is on. _____
(no dish rack is present)
5. Rack Trip Switch is closed (NC) LED is on. _____
*(no dish rack is present)
The rack switch starts the pumps and drive.*
6. LEDs for the lower and upper floats in each tank are labeled on the board as follows:
Wash Flt U = wash tank upper float
Wash Flt L = wash tank lower float
Prewash Flt U = prewash tank upper float
Prewash Flt L = prewash tank lower float
DR Level Rinse Flt U = DR tank single float on single tank machine or the Rinse tank lower float on two tank machines.
Rinse Flt U = rinse tank upper float on two tank machines.
7. As the machine starts to fill the lower floats will rise closing the lower float switch. The lower float LED comes on for each tank as it fills.

8. When the lower float switches close the Heat LEDs will come on and the respective heat circuit outputs are enabled. The booster and wash heat contactors pull in if the thermostats call for heat. The DR heater contactor on a single tank DR machine will pull in if the thermostats call for heat. If the machine is a two tank machine then the rinse tank heater contactors pull in if the thermostats call for heat.

NOTE: The DR and Rinse Heat shares the same LED because the two tank machine never has a DR tank.

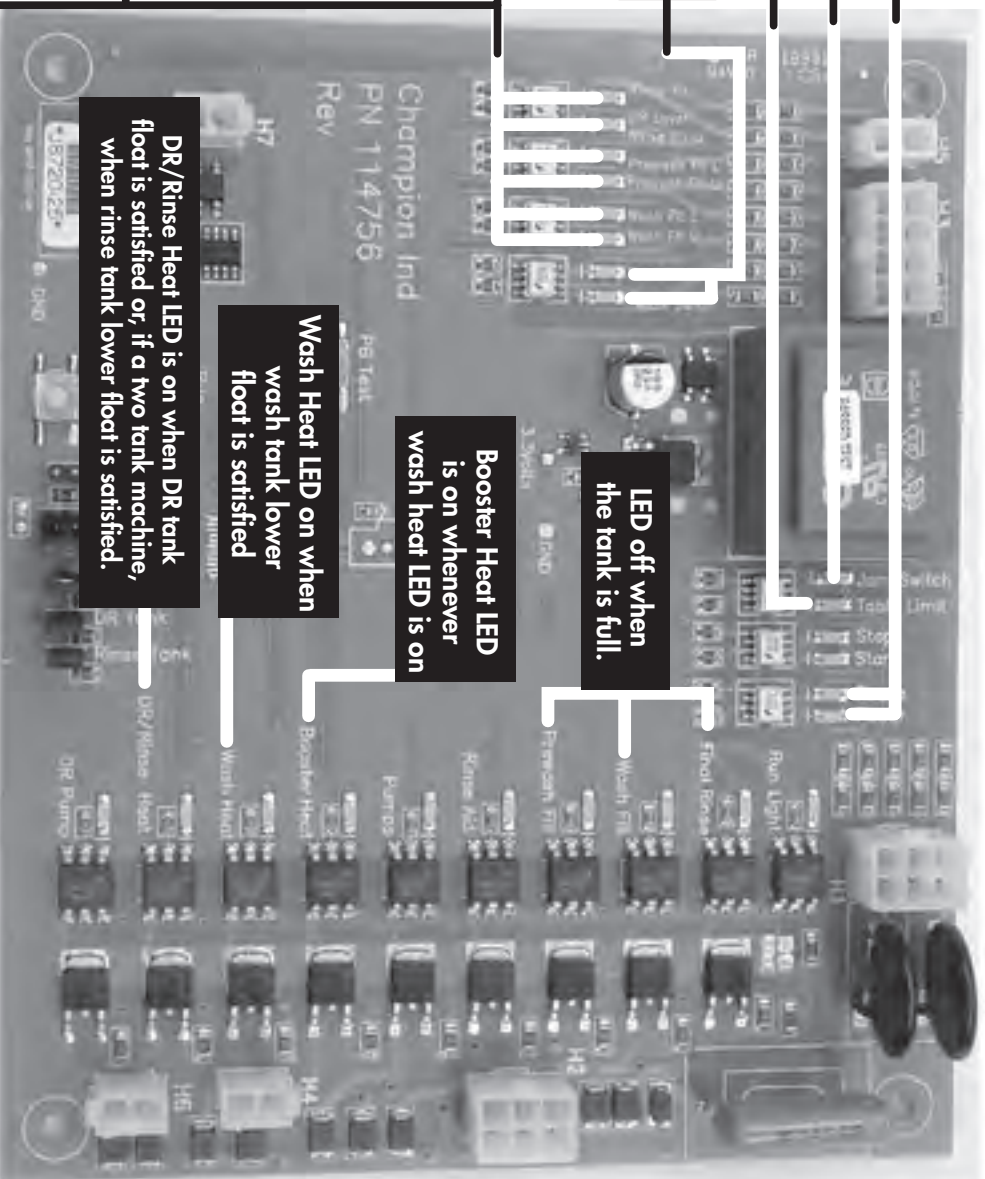

Current State 2:

**Dishwasher power switch is on.
Machine full of water.**

1. Power and Pause LEDs are on.
Drive Jam Switch is closed (NC) LED is on.
Table Limit Switch is closed (NC) LED is on.
Final Rinse Trip Switch is closed (NC) LED is on.
2. Rack Trip Switch is closed (NC) LED is on.
(no rack present)
3. When the green START switch on the front of the control panel is pressed, the Start LED will come on briefly and then go out.
4. At the same time, the Run Light LED will come on and the green light on the front of the control panel will come on.
(Machine is ready to wash dishes.)
5. Inserting a rack of soiled ware into the machine operates the Rack Trip Switch and the Rack Switch LED goes out. (The pumps and drive run.)
6. When the dish rack clears the Rack Trip Switch the Rack Switch LED comes back on.
7. The Pumps LED comes on.
8. The 90 second wash cycle timer counts down.
9. The Digital Display Rinse LED is on and the final rinse temperature gauge on the front of the control cabinet reads "OFF". This is a normal condition indicating that the final rinse trip switch has not been operated by a dish rack.

When the pumps start, an upper float in a tank may drop causing an Flt U LED to go out. This is a normal condition.

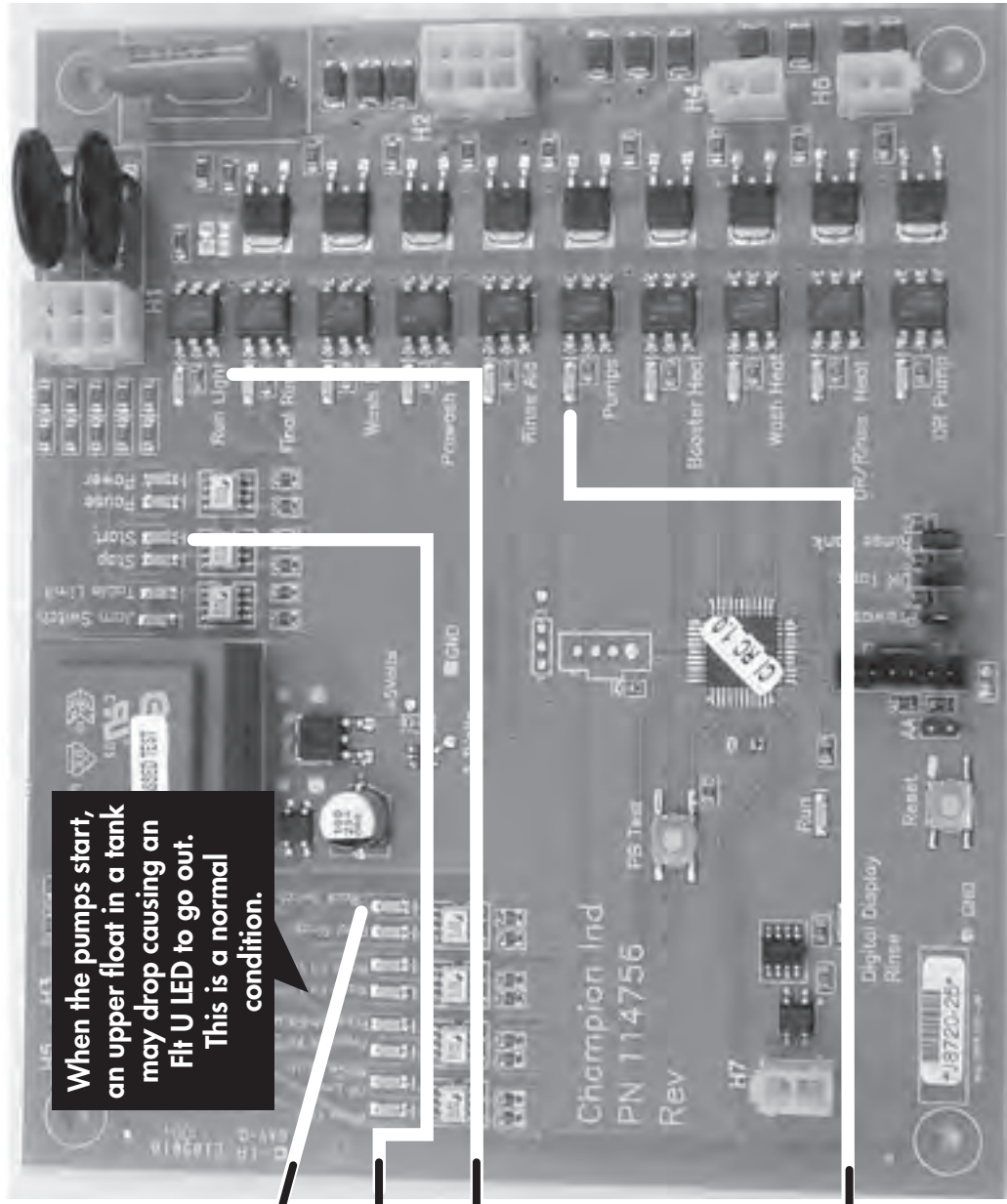

NOTE: EACH ADDITIONAL DISH RACK ENTERING THE MACHINE RESETS THE TIMER.

Current State 3:
Dishwasher power switch is on.
Machine is full of water.
Machine is washing.

1. Power and Pause LEDs are on
Drive Jam Switch is closed (NC) LED is on.
Table Limit Switch is closed (NC) LED is on.
Final Rinse Trip Switch is closed (NC) LED is on.
Rack Trip Switch is closed (NC) LED is on.
(no rack present)
Run Light LED is on.
Green light on front of control panel is on.
The Pumps LED is on.
2. The dish rack moving through the machine trips the final rinse trip switch. The RED Final Rinse INPUT LED goes out.
3. The GREEN Final Rinse OUTPUT LED comes on. *(Final rinse valve energizes.)*
4. The Rinse Aid LED comes on.
(120 VAC rinse aid signal is applied to the rinse aid chemical connection terminal.)
5. DR Pump LED comes on. *(The DR pump runs.)*
6. The Digital Display Rinse LED goes off.
(The final rinse temperature gauge on the front of the control cabinet displays the final rinse water temperature.)
7. When the dish rack moves off the Final Rinse Trip Switch, the Final Rinse switch LED comes on, the Final Rinse valve LED goes out, the Rinse Aid LED goes out, the DR Pump LED goes out, and the Digital Display Rinse LED comes on. *(The final rinse solenoid valve de-energizes, the 120VAC Rinse Aid Chemical Signal is removed, and the final rinse temperature gauge display returns to "OFF".*

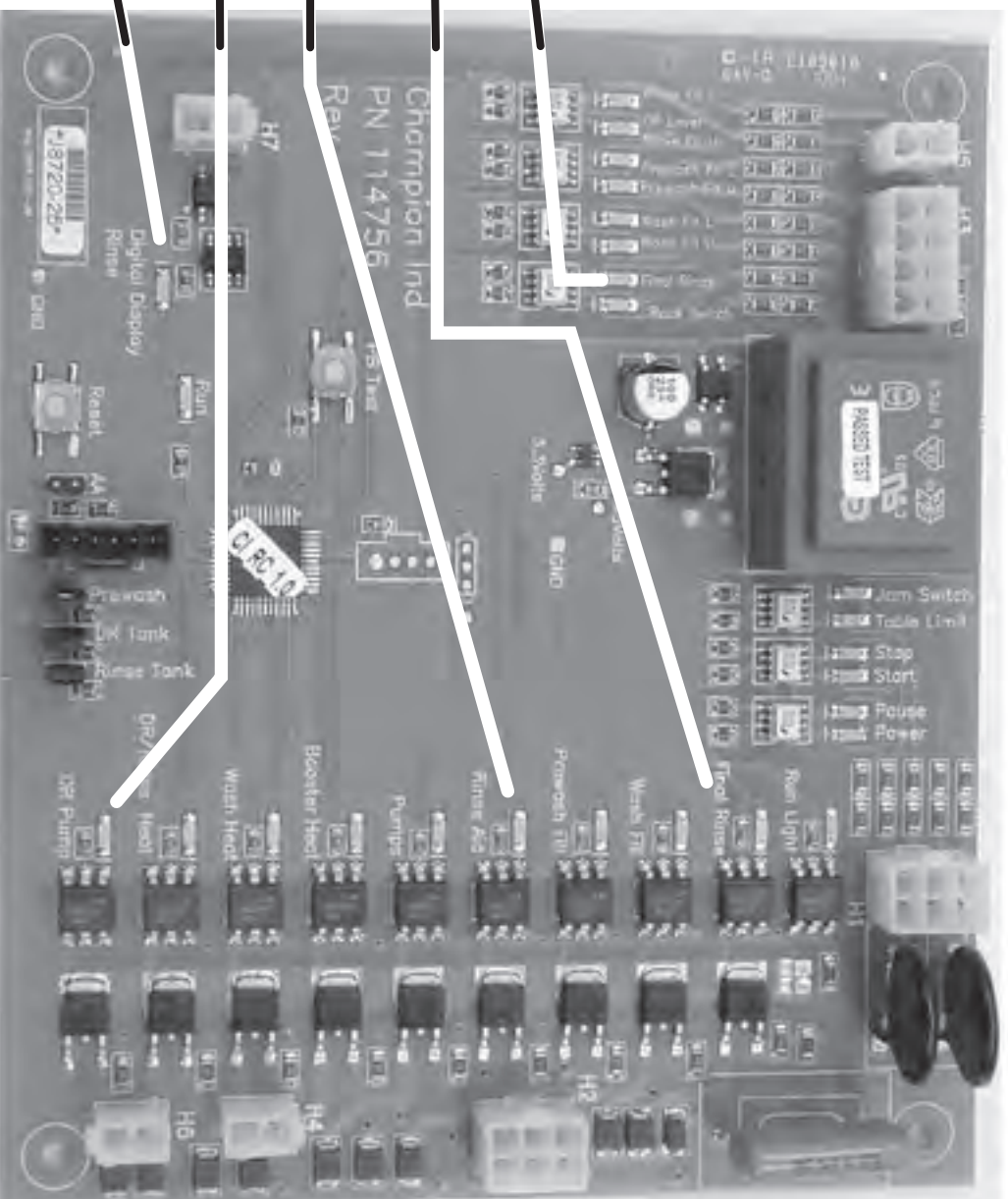

Current State 3 (continued):

**Dishwasher power switch is on.
Machine is full of water.
Machine is washing.**

1. Power and Pause LEDs are on.
Drive Jam Switch is closed (NC) LED is on.
Table Limit Switch is closed (NC) LED is on.
Final Rinse Trip Switch is closed (NC) LED is on.
Rack Trip Switch is closed (NC) LED is on.
(no rack present)
Run Light LED is on.
Green light on front of control panel is on.
The Pumps LED is on.
2. Stop Switch is pressed. The Stop LED comes on and goes out when the stop switch is released.
3. The Run Light LED goes out.
4. The Pumps LED goes out.
(The pumps and drive stop.)
5. Heat LEDs remain on.
(Heating circuits continue to operate normally.)

NOTE:

To restart the wash cycle, press the Start button and insert a dish rack into the machine to activate the Rack Trip Switch.

The Start LED comes on and then goes out, the Run Light LED comes on, the Pumps LED comes on. The machine begins another 90 second cycle.

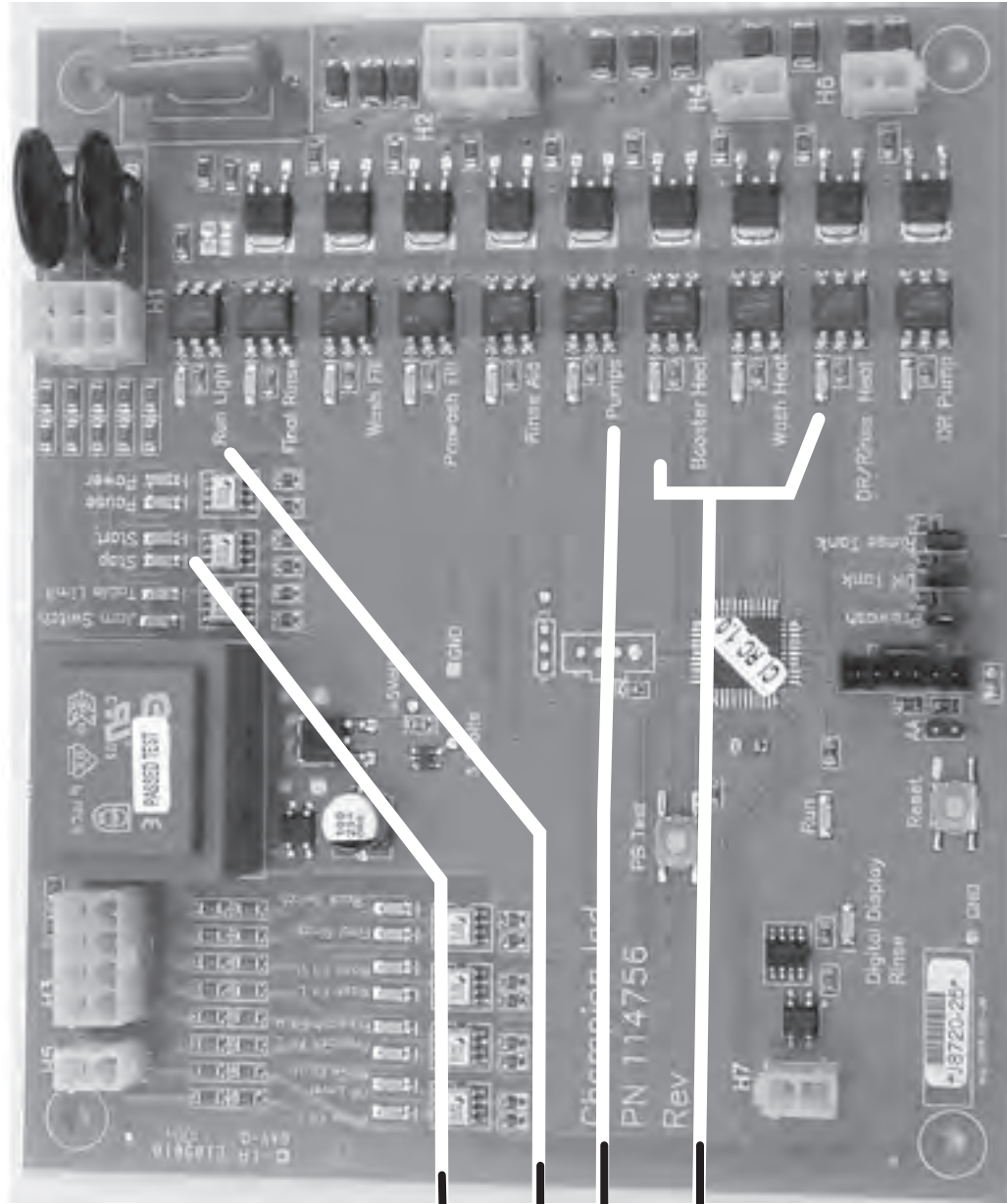

Current State 4: JAM SWITCH OPERATION

Dishwasher power switch is on.

Machine is full of water.

Machine is washing.

1. Power and Pause LEDs are on.
Drive Jam Switch is closed (NC) LED is on.
Table Limit Switch is closed (NC) LED is on.
Final Rinse Trip Switch is closed (NC) LED is on.
Rack Trip Switch is closed (NC) LED is on.
(no rack present)
Run Light LED is on.
Green light on front of control panel is on.
The Pumps LED is on.
2. The rack conveyor, drive motor or
(rack advance table if equipped) jams.
The (NC) Jam switch opens and
The Jam Switch LED goes out.
3. The Run Light LED goes out.
4. The Pumps LED goes out.
5. Heat LEDs remain on.
(Heating circuits continue to operate normally.)
6. Identify and correct the jam condition.
The Jam Switch LED comes on.
*(The most common problem is a ware caught
in the rack conveyor assembly.)*

NOTE:

To restart the wash cycle, press the Start button and insert a dish rack into the machine to activate the Rack Trip Switch.

The Start LED comes on and then goes out,
the Run Light LED comes on, the Pumps LED comes on.
The machine begins another 90 second cycle.

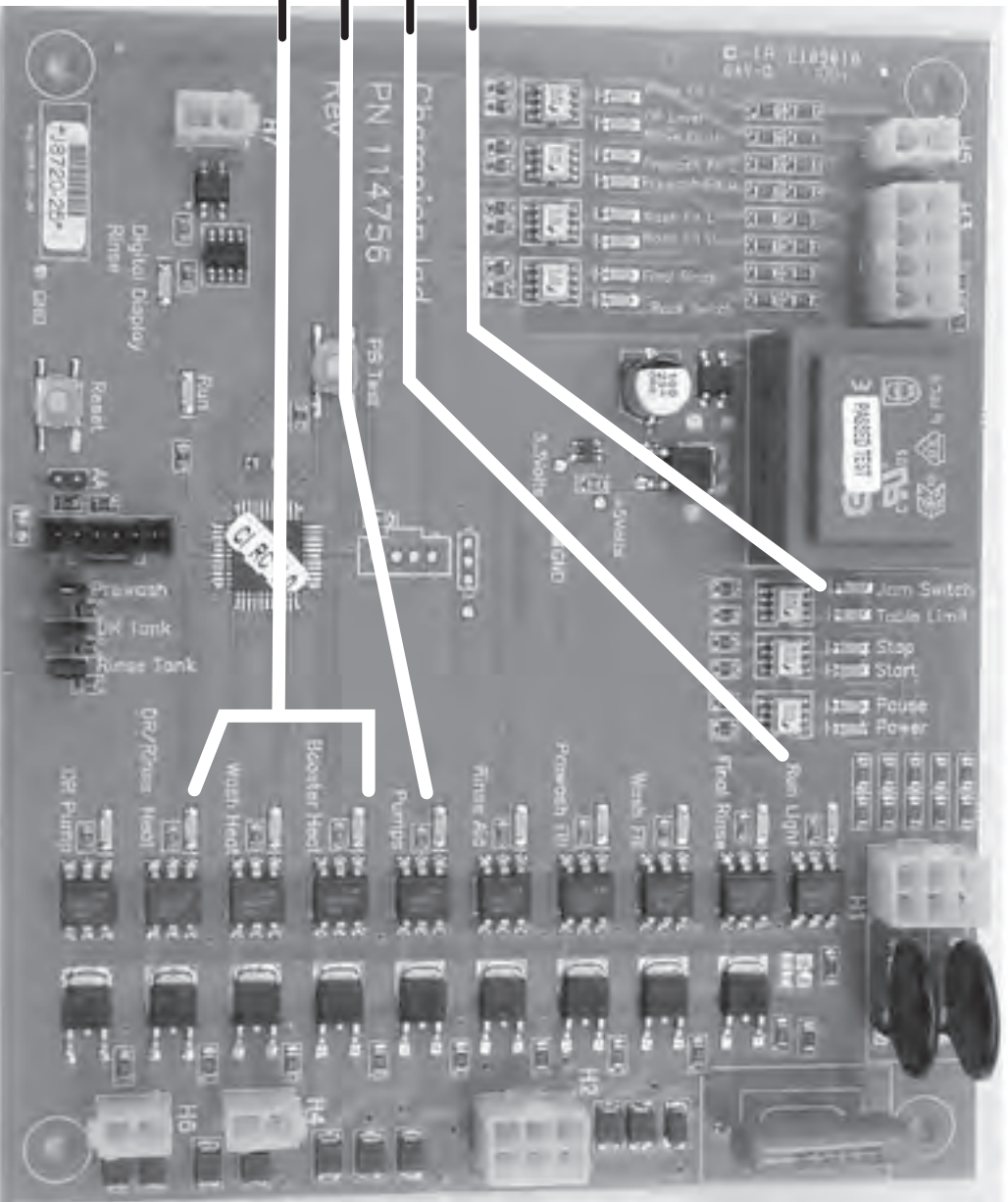

Current State 5: TABLE LIMIT SWITCH (TLS) OPERATION

Dishwasher power switch is on.
Machine is full of water.
Machine is washing.

1. Power and Pause LEDs are on.
Drive Jam Switch is closed (NC) LED is on.
Table Limit Switch is closed (NC) LED is on.
Final Rinse Trip Switch is closed (NC) LED is on.
Rack Trip Switch is closed (NC) LED is on.
(no rack present)
Run Light LED is on.
Green light on front of control panel is on.
The Pumps LED is on.
2. A dish rack activates the table limit switch located on the end of the clean-end dish table.
The (NC) TLS Switch opens.
The Table Limit LED goes out.
3. The Run Light LED is on.
(Pumps and drive stop.)
4. The Pumps LED is off.
5. The 90 second timer pauses.
6. The TLS is deactivated when dish rack is removed.
The Table Limit LED comes on.
7. The Pumps LED comes on.
(Pumps and drive run.)
8. The 90 second timer resumes where it left off.
9. Heat LEDs remained on during TLS operation.
(Heating circuits continued to operate normally.)

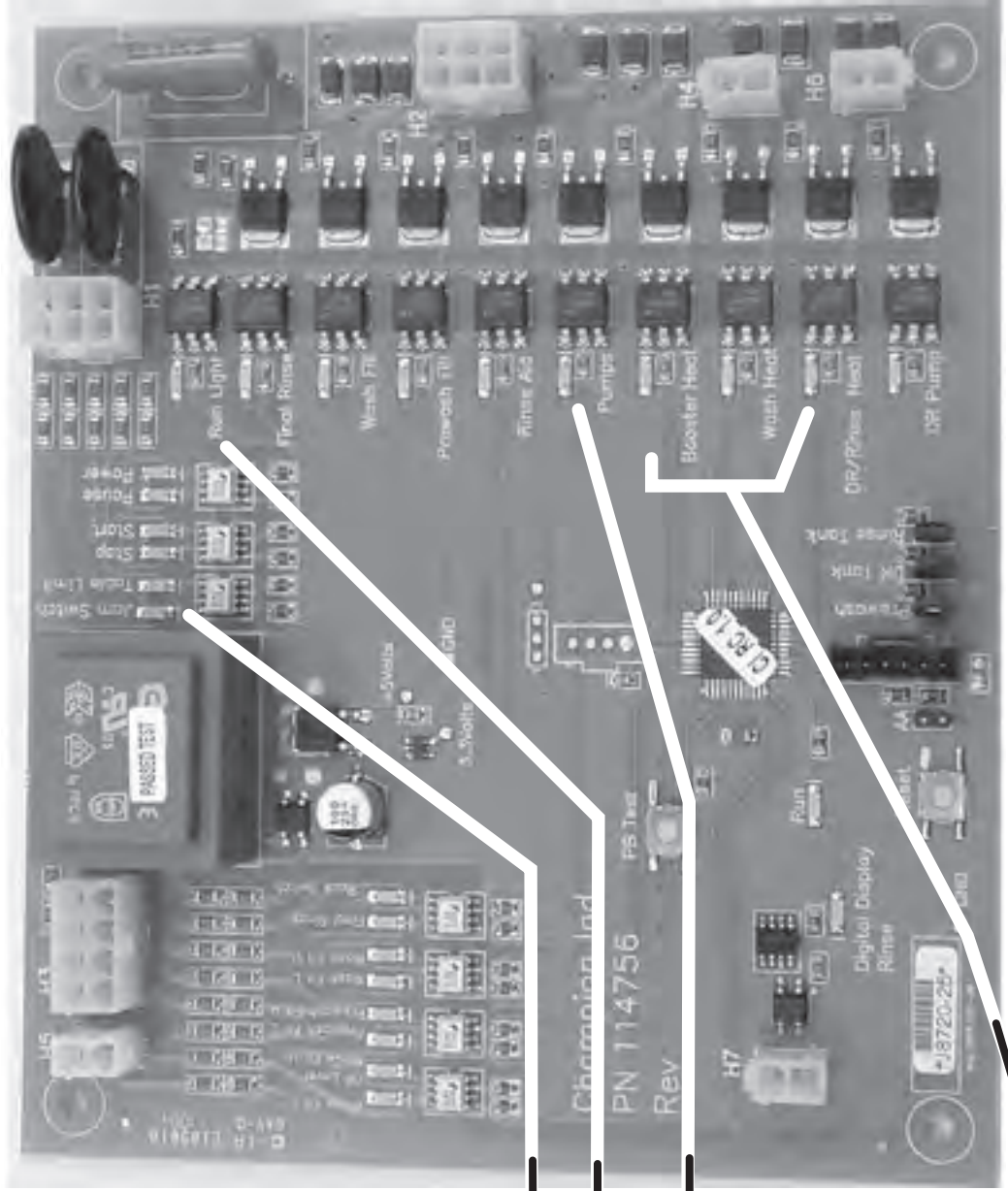

Current State 6: DOOR SWITCH OPERATION

Dishwasher power switch is on.

Machine is full of water.

Machine is washing.

1. Power and Pause LEDs are on.
Drive Jam Switch is closed (NC) LED is on.
Table Limit Switch is closed (NC) LED is on.
Final Rinse Trip Switch is closed (NC) LED is on.
Rack Trip Switch is closed (NC) LED is on.
(no rack present)
Run Light LED is on.
Green light on front of control panel is on.
The Pumps LED is on.
2. A door is opened during the wash cycle.
The Pause LED goes out.
3. The Run Light LED remains on.
4. The Pumps LED goes out.
(All pumps and drive stop.)
5. When the door is opened, all Heat, Fill, Final Rinse, Rinse Aid, DR Pump LEDs go out.
(Heat circuits, fill circuits are de-energized.)
6. If door is closed before 5 minutes has elapsed the machine will resume operation automatically and all LEDs will return to their normal states.
7. If the door remains open for more than 5 minutes the machine must be restarted.
8. To restart the wash cycle, press the Start button and insert a dish rack into the machine to activate the Rack Trip Switch. The Start LED comes on and then goes out, the Run Light LED comes on, the Pumps LED comes on. The machine begins another 90 second cycle.

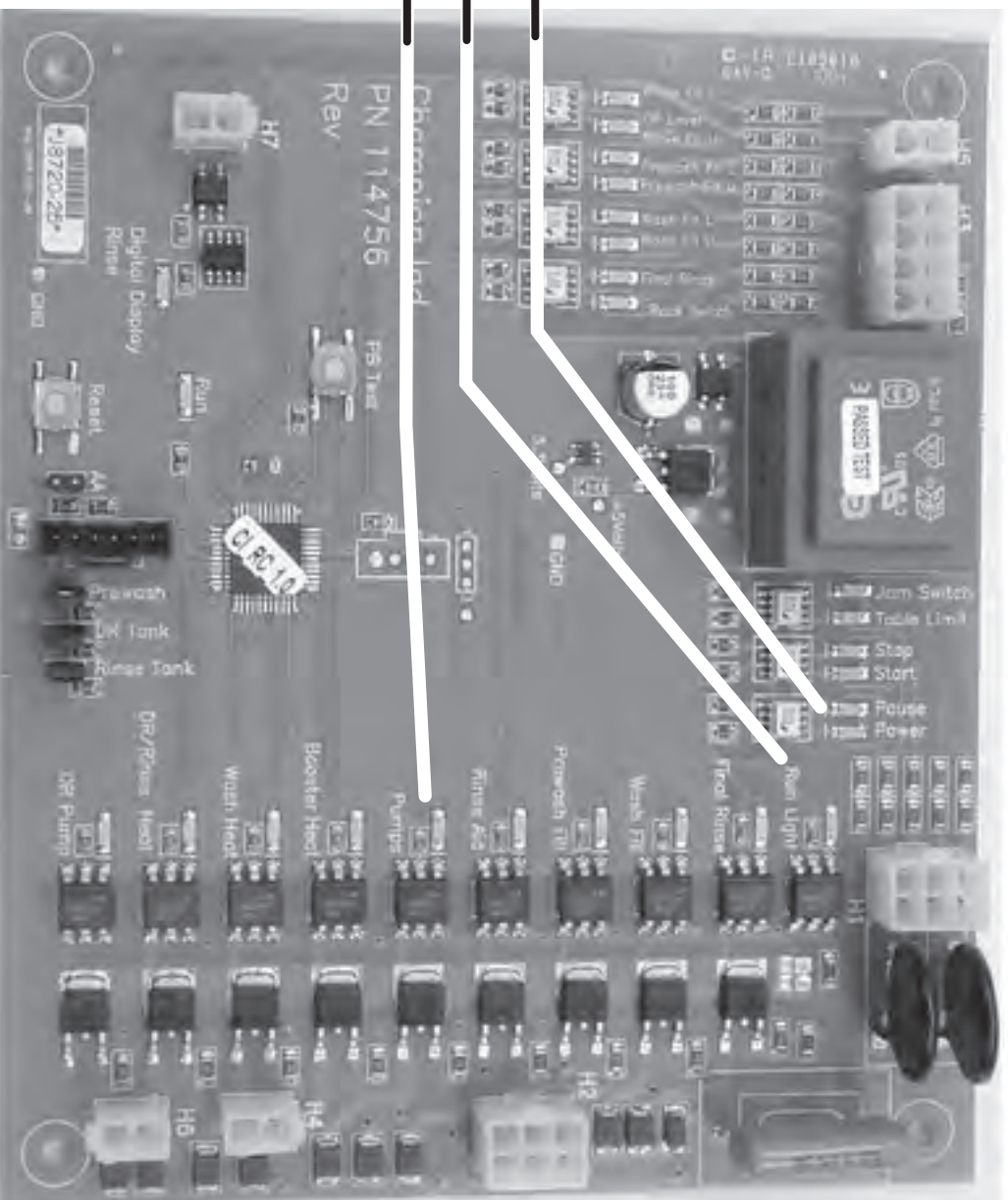

Current State 7: FLOAT SWITCH OPERATION

Dishwasher power switch is on.
Machine is full of water.
Machine is washing.

1. Power and Pause LEDs are on.
Drive Jam Switch is closed (NC) LED is on.
Table Limit Switch is closed (NC) LED is on.
Final Rinse Trip Switch is closed (NC) LED is on.
Rack Trip Switch is closed (NC) LED is on.
(no rack present)
Run Light LED is on.
Green light on front of control panel is on.
The Pumps LED is on.
2. Under normal operating conditions, the lower and upper floats are up and the LEDs are on.
3. The Pumps LED is on. *(All pumps and drive are running.)*
5. The Heat LEDs are on and circuits enabled. *(Tank heaters will be energized if thermostats are calling for heat.)*
6. If the water level falls in a tank and the upper float drops, the associated Flt U LED will go out. *(Heat circuit for the tank remains enabled.)*
7. If the water level in a tank continues to fall and the lower float drops, the associated Flt L LED will go out. *(Heat circuit for the tank is disabled.)*
8. The Pumps LED remains on. *(All pumps and drive continue to run.)*
9. The associated Fill LED comes on; the fill valve(s) will energize and the tank(s) will fill with water. The Flt L LED and Flt U LED for each tank will come on as the tank fills.

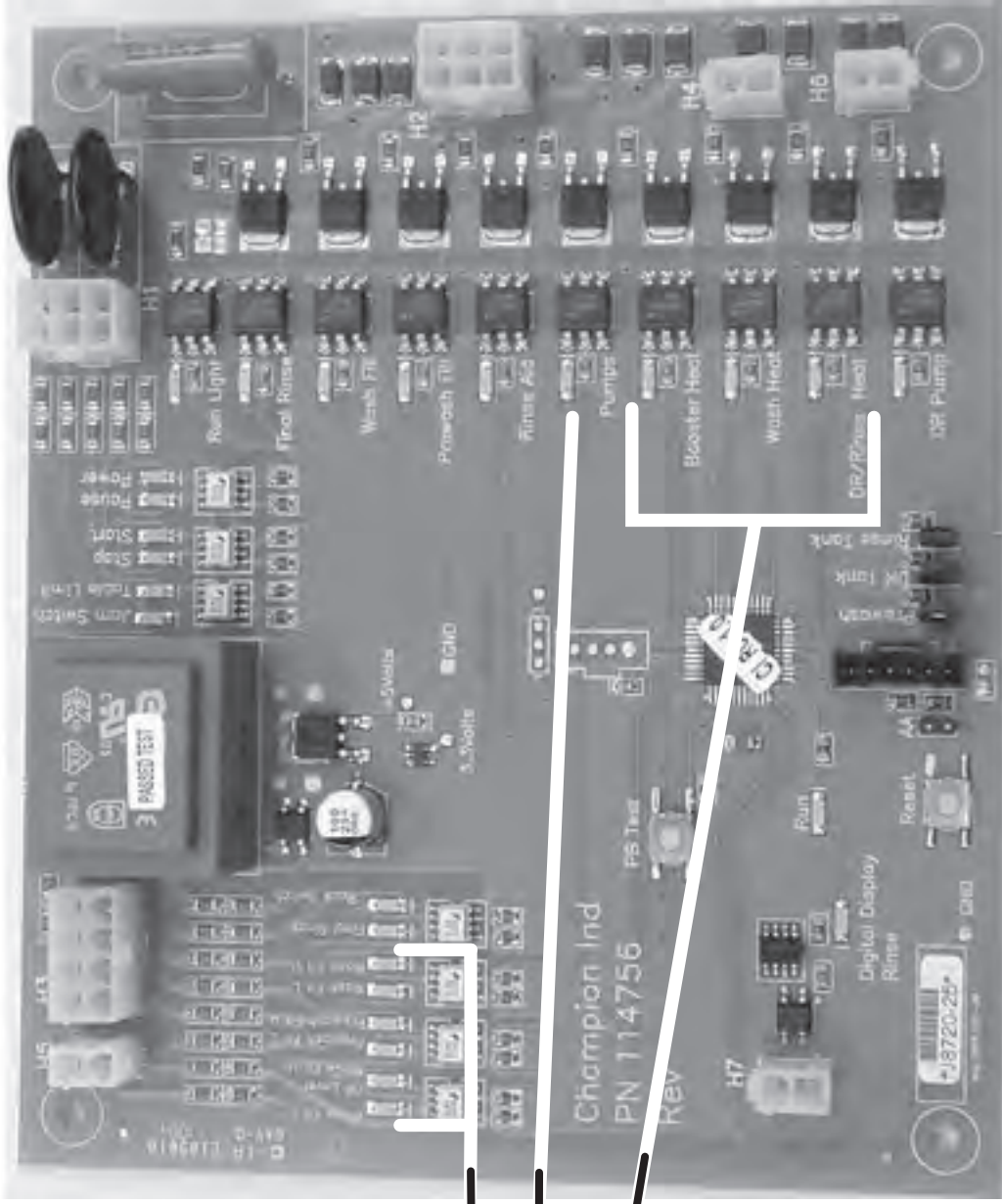

NOTE:

If the machine fills for more than 20 minutes, the machine will shut down and the Run Light LED will begin flashing. Check drains etc. then turn the machine Power Switch off and back on to reset the machine.

Current State 8: SHUTDOWN

Dishwasher power switch is on.

Machine is full of water.

Machine is washing.

1. Power and Pause LEDs are on.
Drive Jam Switch is closed (NC) LED is on.
Table Limit Switch is closed (NC) LED is on.
Final Rinse Trip Switch is closed (NC) LED is on.
Rack Trip Switch is closed (NC) LED is on.
(no rack present)
Run Light LED is on.
Green light on front of control panel is on.
The Pumps LED is on.
2. Turn machine power switch off.
3. All LEDs go out.
4. Run LED goes out indicating the control board no longer has power.

