

Champion®

The Dishwashing Machine Specialists

For models beginning with Serial No. R3171

Technical Manual



44

Single Tank

44
54
44LT
66LT
44WS
66PWWS
44 MODULAR

44DR
44DRWS
66DRPW
66DRWSPW

**E-Series Single Tank
and Two Tank
Rack Conveyor
with/without Prewash**



64

Two Tank

64
72
84
64 MODULAR

Two Tank w/Prewash

86PW
90FFPW
100HDPW
86PW MODULAR
94PW

94FFPW
108HDPW
106PW
110FFPW
120HDPW



66PW

Single Tank w/Prewash

66PW
70FFPW
80HDPW
66PW MODULAR
76PW
80FFPW
90HDPW

66DRPW
80DRHDPW
80DRWSHDPW

Machine Serial No.

May, 2005

Manual P/N 113867 Rev D

P. O. Box 4149
Winston-Salem, North Carolina 27115-4149
336/661-1556 Fax: 336/661-1660

2674 N. Service Road
Jordan Station, Ontario, Canada L0R 1S0
905/562-4195 Fax: 905/562-4618

Complete the information below so it will be available for quick reference.

Model Number _____ Serial Number _____

Voltage and Phase _____

Champion Service Agency _____ Phone _____

Champion Parts Source _____ Phone _____

Champion Service:

Champion (USA)

Phone: 1 (336) 661-1556

1 (800) 858-4477

Fax: 1 (336) 661-1660

Champion (Canada)

Phone: 1 (905) 562-4195

1 (800) 263-5798

Fax: 1 (905) 562-4618

We strongly recommend that you Fax your orders.

NOTE: When calling to order parts, be sure to have the model number, serial number, voltage and phase of your machine.

REVISION HISTORY

Revision Date	Revised Pages	Serial Number Effectivity	Comments
07/15/04	All		First issue of manual and replacement parts
08/31/04	7		Revised operation procedure.
08/31/04	12		Revised the pump timer operation sequence.
08/31/04	13		Revised the float switch information.
8/31/04	14		Revised the terminal connections drawings and inserted figure number for electric booster.
8/31/04	18		Added drive motor wiring drawings and information.
09/01/04	20		Part number 328473 replaced by 328977. Added 36" Prewash panels.
9/01/04	20, 23, 25	R3448	Added new door catch components.
9/01/04	23		Part number 327890 replaced by 328974. Added entrance and exit curtain baffles.
9/01/04	25		Part number 327891 replaced by 328975. Added E84 front panels.
9/01/04	31		Part number 328799 replaced by 328450. Added new cradle bracket for two tank machines.
9/01/04	37		Updated part numbers for scrap screens and refuse baskets.
9/01/04	61, 63		Updated part numbers for drain levers and overflow rod.
9/01/04	64, 66		Corrected piping drawings.
9/01/04	73		Changed part number 113727 discharge hose to 112807.
12/16/04	51, 53, 77		Added 575 volt elements and corrected part number for 10KW element.
2/16/05	91		Added revised schematics.
5/16/05	91		Added revised schematics.

REVISION RECORD (CONT'D)

CONTENTS

	Page
REVISION HISTORY	i
WARRANTY	v
SAFETY SUMMARY	vi
INTRODUCTION	1
GENERAL	2
INSTALLATION	3
Unpacking	3
Plumbing Connections	3
Electrical Connections	4
Ventilation Connections	4
Chemical Connections	5
Curtain Locations	5
Completing Installation	6
OPERATION	8
Initial Startup	8
Basic Operation	8
MAINTENANCE	9
Maintenance Schedule	9
Deliming	10
ELECTRICAL SERVICE	11
REPLACEMENT PARTS	19
ELECTRICAL SCHEMATICS	93

LIST OF FIGURES

Figure 1 — Motor Rotation	4
Figure 2 — Scrap Basket Removal	9
Figure 3 — Motor Overload	9
Figure 4 — Unhooking Upper Arm	9
Figure 5 — Upper Wash Arm Removal	9
Figure 6 — Lower Wash Arm Removal	9
Figure 7 — End Cap Removal	9
Figure 8 — Fuse Blocks	11
Figure 9 — Motor Overloads	11
Figure 10 — Pump Timer	12
Figure 11 — Dual Float Switch	13
Figure 12 — Tank Heat Thermostats	14
Figure 13 — Booster Thermostat Location	14
Figure 14 — Booster High Limit Thermostat	14
Figure 15 — Prewash Panels, Doors and Miscellaneous	20

CONTENTS (CONT.)

LIST OF FIGURES

Figure 16 — Single Tank Panels, Doors and Miscellaneous	22
Figure 17 — Two Tank Doors, Panels and Miscellaneous	24
Figure 18 — Drive Motor Assembly	26
Figure 19 — Drive Assembly	28
Figure 20 — Prewash Track and Cradle Assembly	30
Figure 21 — Single Tank Track and Cradle Assembly	32
Figure 22 — Two Tank Track and Cradle Assembly	34
Figure 23 — Prewash Screens	36
Figure 24 — Single Tank Scrap Screens	28
Figure 25 — Two Tank Scrap Screens	40
Figure 26 — Prewash Spray Arms	42
Figure 27 — Single Tank Wash Arms (Left to Right Shown)	44
Figure 28 — Two Tank Wash and Rinse Arms (Left to Right Shown)	46
Figure 29 — Float Switch	48
Figure 30 — Single Tank Electric Tank Heat	50
Figure 31 — Two Tank Electric Tank Heat	52
Figure 32 — Single Tank Steam Tank Heat	54
Figure 33 — Two Tank Steam Tank Heat	56
Figure 34 — Tank Thermostats	58
Figure 35 — Prewash Overflow	60
Figure 36 — Single Tank and Two Tank Overflow Assembly	62
Figure 37 — Final Rinse Piping w/Booster	64
Figure 38 — Final Rinse Piping no Booster/ with Steam Booster	66
Figure 39 — Final Rinse Drain Assembly	68
Figure 40 — Prewash Pump Suction/Discharge	70
Figure 41 — Wash/Rinse Pump Suction/Discharge	72
Figure 42 — Pump Assembly	74
Figure 43 — 40°/60° Rise Electric Booster	76
Figure 44 — 70° Rise Electric Booster.....	78
Figure 45 — Control Cabinet	80
Figure 46 — New Style Vent Cowls (Shown Mounted to Prewash)(Optional)	82
Figure 47 — Standard Vent Cowls (Optional)	84
Figure 48 — Racks	88

LIMITED WARRANTY

Champion Industries Inc. (herein referred to as Champion), P.O. Box 4149, Winston-Salem, North Carolina 27115, and P.O. Box 301, 2674 N. Service Road, Jordan Station, Canada, L0R 1S0, warrants machines, and parts, as set out below.

Warranty of Machines: Champion warrants all new machines of its manufacture bearing the name "Champion" and installed within the United States and Canada to be free from defects in material and workmanship for a period of one (1) year after the date of installation or fifteen (15) months after the date of shipment by Champion, whichever occurs first. [See below for special provisions relating to glasswashers.] The warranty registration card must be returned to Champion within ten (10) days after installation. If warranty card is not returned to Champion within such period, the warranty will expire after one year from the date of shipment.

Champion will not assume any responsibility for extra costs for installation in any area where there are jurisdictional problems with local trades or unions.

If a defect in workmanship or material is found to exist within the warranty period, Champion, at its election, will either repair or replace the defective machine or accept return of the machine for full credit; provided, however, as to glasswashers, Champion's obligation with respect to labor associated with any repairs shall end (a) 120 days after shipment, or (b) 90 days after installation, whichever occurs first. In the event that Champion elects to repair, the labor and work to be performed in connection with the warranty shall be done during regular working hours by a Champion authorized service technician. Defective parts become the property of Champion. Use of replacement parts not authorized by Champion will relieve Champion of all further liability in connection with its warranty. In no event will Champion's warranty obligation exceed Champion's charge for the machine. The following are not covered by Champion's warranty:

- a. Lighting of gas pilots or burners.
- b. Cleaning of gas lines.
- c. Replacement of fuses or resetting of overload breakers.
- d. Adjustment of thermostats.
- e. Adjustment of clutches.
- f. Opening or closing of utility supply valves or switching of electrical supply current.
- g. Cleaning of valves, strainers, screens, nozzles, or spray pipes.
- h. Performance of regular maintenance and cleaning as outlined in operator's guide.
- i. Damages resulting from water conditions, accidents, alterations, improper use, abuse, tampering, improper installation, or failure to follow maintenance and operation procedures.
- j. Wear on Pulper cutter blocks, pulse vanes, and auger brush.

Examples of the defects not covered by warranty include, but are not limited to: (1) Damage to the exterior or interior finish as a result of the above, (2) Use with utility service other than that designated on the rating plate, (3) Improper connection to utility service, (4) Inadequate or excessive water pressure, (5) Corrosion from chemicals dispensed in excess of recommended concentrations, (6) Failure of electrical components due to connection of chemical dispensing equipment installed by others, (7) Leaks or damage resulting from such leaks caused by the installer, including those at machine table connections or by connection of chemical dispensing equipment installed by others, (8) Failure to comply with local building codes, (9) Damage caused by labor dispute.

Warranty of Parts: Champion warrants all new machine parts produced or authorized by Champion to be free from defects in material and workmanship for a period of 90 days from date of invoice. If any defect in material and workmanship is found to exist within the warranty period Champion will replace the defective part without charge.

DISCLAIMER OF WARRANTIES AND LIMITATIONS OF LIABILITY. CHAMPION'S WARRANTY IS ONLY TO THE EXTENT REFLECTED ABOVE. CHAMPION MAKES NO OTHER WARRANTIES, EXPRESS OR IMPLIED, INCLUDING, BUT NOT LIMITED, TO ANY WARRANTY OF MERCHANTABILITY, OR FITNESS OF PURPOSE. CHAMPION SHALL NOT BE LIABLE FOR INCIDENTAL OR CONSEQUENTIAL DAMAGES. THE REMEDIES SET OUT ABOVE ARE THE EXCLUSIVE REMEDIES FOR ANY DEFECTS FOUND TO EXIST IN CHAMPION DISHWASHING MACHINES AND CHAMPION PARTS, AND ALL OTHER REMEDIES ARE EXCLUDED, INCLUDING ANY LIABILITY FOR INCIDENTALS OR CONSEQUENTIAL DAMAGES.

Champion does not authorize any other person, including persons who deal in Champion dishwashing machines to change this warranty or create any other obligation in connection with Champion Dishwashing Machines.

SAFETY SUMMARY

Safety Symbols

- The following symbols appear throughout this manual alerting you to potential hazards. Statements associated with each symbol are printed on *italics*.



WARNING:

Warning statements indicate any condition or practice that could result in personal injury or possible loss of life.



CAUTION:

Caution statements indicate any condition or practice which, if not strictly observed or remedied, could result in damage to or destruction of the dishwasher.



NOTE:

Note statements indicate any condition or practice which, if observed, will help in the safe completion of a task.

General Safety Rules

- The following general safety rules must be observed in addition to the specific cautions and warnings presented in this manual.
- Your Champion pot and pan washer uses hot water to clean and sanitize a variety of wares. Machine surfaces and wares become hot during and immediately following normal operations. Operators should use caution when loading and unloading wares from the machine.
- Operators must NOT bypass a safety interlock or control(s) to operate unit.
- The service and maintenance instructions contained in this manual are intended for qualified service personnel. These instructions assume that you are trained in basic electricity and mechanical theory. If you are not a trained technician, then do not attempt to adjust or repair the dishwasher as serious personal injury or damage to the dishwasher may result.

INTRODUCTION

Welcome to **Champion**....

and thank you for allowing us to take care of your dishwashing needs.

This manual covers several models. Model numbers are shown on the front cover.

Your machine has been completely assembled, inspected, and thoroughly tested at our factory before it was shipped to your installation site.

This manual contains:

- Warranty information
- Operation and cleaning instructions
- Maintenance instructions
- Troubleshooting guide
- Basic service information
- Replacement parts lists
- Electrical schematics

Complete and return your warranty registration card within ten (10) days after the installation of your machine.

All information, illustrations and specifications contained in this manual are based upon the latest product information available at the time of publication. **Champion** constantly improves its products and reserves the right to make changes at any time or to change specifications or design without notice and without incurring obligation.

For your protection, factory authorized parts should always be used for repairs.

Replacement parts may be ordered from your **Champion** authorized service agency. When ordering parts, please supply the model number, serial number, voltage and phase of your machine, the part number, part description, and quantity.

GENERAL

This manual covers the Champion single tank and two tank rack conveyor dishwashing machines. These machines are fully automatic and are equipped with 1 HP prewash and 2HP wash and rinse pump motors (depending on the model) and a 1/6 HP conveyor drive motor. All models are available for a right-to-left or left-to-right operation.

These series of dishwashers are modular in design. The following models and options are covered in this manual:

Model Numbers

Single Tank - Basic.....44, 54, 44 WS, 44 LT
Single Tank with 22" Prewash.....66 PW, 76 PW, 66 WS, 66 LT PW
Single Tank with 36" Prewash.....80 HDPW, 90 HDPW, 80WS HDPW
Single Tank with 26" Front Feed Prewash.....70 FFPW,80 FFPW, 70 WS FFPW

- The 44 and 54 basic models along with their respective prewash options, are high temperature (180°F/80°C final rinse) sanitizing models.
- The 44 WS models along with their respective prewash options, are water and energy saving, high temperature (180°F/80°C final rinse) sanitizing models.
- The 44 LT model, along with its respective prewash option, is a low temperature (140°F/60°C final rinse), chemical sanitizing model for use with sodium hypochlorite solution (chlorine bleach) as the sanitizing agent.

Two Tank - Basic.....64, 72, 84
Two Tank with 22" Prewash.....86 PW, 94 PW, 106 PW
Two Tank with 36" Prewash.....100 HDPW, 108 HDPW, 120 HDPW
Two Tank with 26" Front Feed Prewash.....90 FFPW, 98 FFPW, 110 FFPW

- The 64, 72 and 84 basic models, along with their respective prewash options, are high temperature (180°F/80°C final rinse) sanitizing models.

INSTALLATION

Unpacking

**CAUTION:**

Care should be taken when lifting the machine to avoid damaging the piping under the base. Remove the dishwasher front panels and lift from the front with a forklift.

1. Immediately after unpacking your machine, inspect for any shipping damage. If damage is found, save the packing material and contact the carrier immediately.
2. Remove the dishwasher from the skids. Adjust the feet if required, then move the machine to its permanent location. The machine should not be installed within 6 inches [153mm] of any wall or structure.
3. Level the machine by placing a level on top of the machine and adjust the feet. Level the machine by unscrewing the feet from the base. Adjust from the front-to-back and side-to-side.

Plumbing Connections

**CAUTION:**

Plumbing connections must comply with local sanitary and plumbing codes.

1. Connect the hot water supply at the final rinse piping connection located behind the control cabinet at the top of the machine.
2. A “Y” strainer is provided by Champion for machines without booster. A pressure reducing valve (PRV) is provided by Champion for machines with built-in boosters.
3. If the incoming hot water supply pressure exceeds 25psi [173kPa] at machine, a PRV must be installed and set to 20-22psi [138-151 kPa]. The PRV may be purchased from Champion or supplied by others.
4. Install a manual shut-off valve in the steam and water supply lines to accommodate servicing the machine. The valve should be the same size as/or larger than the supply line.
5. Provide suitable gravity drain to connect to a 1-1/2" NPT drain pipe.

INSTALLATION (CONT.)

Electrical Connections



NOTE:

Electrical and grounding connections must comply with the National Electrical Code and/or Local Electrical Codes.



WARNING:

When working on the dishwasher, disconnect the electric service and tag it to indicate work is being done on that circuit.



NOTE:

Electric boosters require a separate electrical connection (except the 44WS and 66 WS PW models that have a single point connection).

A fused disconnect switch or circuit breaker (supplied by user) is required to protect each power supply circuit.

1. Compare the electrical specifications on the machine electrical connection plate (located inside the control cabinet) to the electrical power supply before connecting to the incoming service at a fused disconnect switch.
2. Motor rotation is set at the factory. Ensure proper rotation of the conveyor drive shaft (red arrow on side of motor shows direction of rotation). Single phase drive motor (208-240V only) rotation must be changed at the drive motor junction box. Three phase drive motor (480-575V) rotation must be reversed in the control cabinet. Reversing the pump motor(s) direction is done in the control cabinet by reversing the wires L1 and L2 on the disconnect switch side of the main electrical connection terminal block (refer to the electrical diagrams in the back of this manual).
3. A knock-out plug is provided at the rear of the control cabinet for electrical service connections.



Figure 1- Motor Rotation

Ventilation



CAUTION:

Exhaust air should never be vented into a wall, ceiling, or concealed space if a building as condensation will cause damage.

1. Stainless steel watertight ducting should be installed **INSIDE** the 4" x 16" [102mm x 407mm] vent stacks at the load and unload ends. A minimum of 6 air changes per hour of kitchen air is recommended. The typical exhaust ventilation requirements for a rack machine using a 180°F/82°C final rinse are:
 - The load end requires 150 CFM @ 1/4" (SP), [71 Liters/Sec] with prewash.
 - The load end requires 200 CFM @ 1/4" (SP), [95 Liters/Sec] without prewash.
 - The unload end requires 400 CFM @ 1/4" (SP), [189 Liters/Sec].
2. An adjustable damper is supplied with the optional vent stacks for regulating the exhaust volume.

INSTALLATION (CONT.)

Chemical Connections

1. Use a qualified detergent/chemical supplier for detergent/chemical and dispensing equipment needs.
2. Labeled detergent control circuit connection terminals are provided in the control cabinet for detergent and rinse agent/sanitizer dispensing equipment (supplied by others).
3. The illustration on the right, shows the terminal board for the current production machines. The signal connection points include:
 - Detergent signal 120VAC, 1Amp max amp load
 - Rinse aid/Sanitizer signal 120VAC, 1Amp max amp load
4. A removable black plug is provided in the load end side of the wash tank (behind the drive motor) for installation of the detergent conductivity cell.

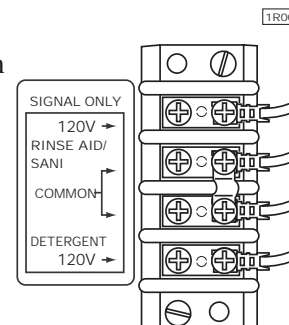

Chemical Connection Terminal Board

Curtain Locations

1. Refer to the illustrations below and hang the curtains as shown. J-hooks are located in the corners of each section to accept the curtain rods.
 - Standard long curtains 24" x 20-1/4" [610mm x 515mm]
 - High hood long curtains 24" x 22-3/4" [610mm x 578mm]
 - Standard short curtains 24" x 13-1/4" [610mm x 337mm]
 - High hood short curtains 24" x 20-1/4" [610mm x 515mm]
 - Final rinse curtain 24" x 6-1/4" [610mm x 159mm]
2. Make sure the that the short flaps of the curtains face the load end of the dishwasher. The longest curtains always go on each end of the dishwasher.

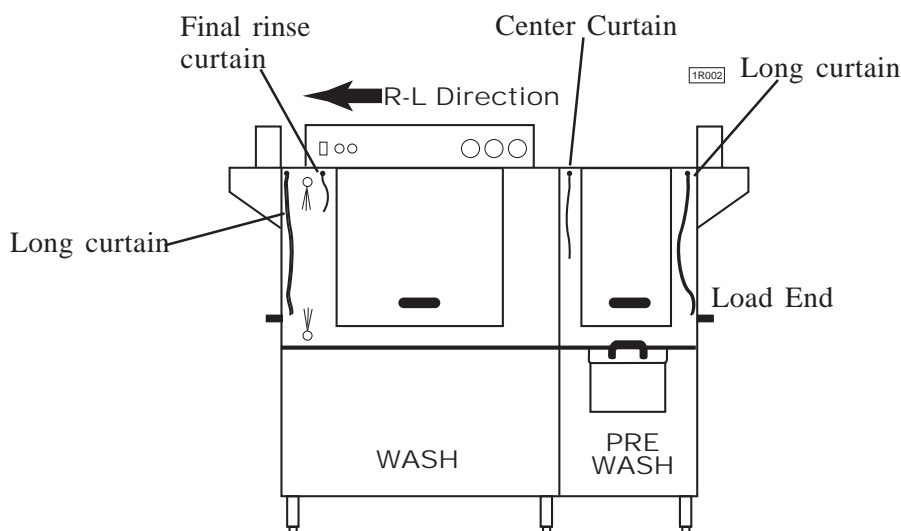

**Curtain Locations
(machine with prewash shown)**

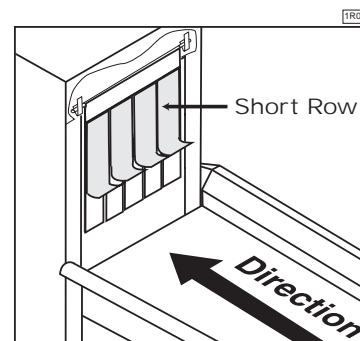

Short row of curtains face out to the load end (or unload depending the location of the curtain) of the dishwasher.

INSTALLATION (CONT')

Completing Installation



WARNING:

Do not insert racks into the machine before the tanks fill with water and have reached the proper temperatures. Operating the pumps dry will cause pump seal damage and leakage that can result in a motor failure.

1. Remove any foreign material from inside of the machine.
2. Check to insure that the drains/overflow pipes are operational and sealed.
3. Position scrap screens on the supports above the tanks.
4. After all plumbing and electrical connections are completed, fill the tank and wait 10 minutes.
Check all plumbing connections for leaks.
5. Drain the tank and check the drain lines for leaks.
6. The formed down lip of the dishtable should be placed inside of the machine. The dishtable should be pitched toward the dishwasher for proper draining by adjusting its leveling feet. The dishtable should be sealed to the dishwasher.

OPERATION

Follow the procedure below to operate your dishwasher properly.

1. Verify that the spray pipes, curtains, and scrap screens are in place and clean.
2. Verify that the overflow drains are closed.
3. Turn on the detergent dispenser switches and check the detergent supply.
4. Turn on the exhaust vent system (if applicable), and make sure it is operating.
5. Close the door(s). Push the power switch ON, light will illuminate. Machine will begin to fill (with or without a booster, machine fills thru the fill valve and through the final rinse).
6. When the tanks are full, wait until the wash tank has reached the proper temperature. Check the wash tank temperature gauges located on the control cabinet. Minimum wash temperatures are:
 - 44 LT, 66 LT PW - **140°F/60°C**
 - 44, 54, 44 WS - **150°/66°C**
 - 66 PW, 76 PW, 66 WS PW - **160°/71°C**
7. Press the Green Lighted **START** Pushbutton on the control cabinet. This will activate the automatic operation for the drive motor and the pumps. The green light will come on. No other noticeable action will happen until the first rack is loaded into the machine.
8. Scrap and pre-flush all items to be placed and load items into racks.



NOTE:

DO NOT OVERLOAD RACKS.

Pegged racks are for plates and/or trays. Flat racks are for bowls and/or silverware. Spread silverware evenly in a single layer in a flat rack or upright (loosely packed) in a cutlery rack/cylinder.

9. Push the rack into the machine, the conveyor and drive system will grab the rack and pull it into the machine. The rack start lever (idle pump switch) will start the pumps and the system will run a cycle for 90 seconds. When another rack is inserted it resets the pumps for another 90 second cycle.
10. Check the final rinse pressure and temperature as the racks pass through the final rinse. This final rinse pressure **MUST** be 20-22 psi [138-151 kPa] and the final rinse temperature **MUST** be a minimum of 180°F/82°C .
11. The pumps and the conveyor drive will automatically stop after the last rack leaves the machine and the 90 second cycle time has completed.
12. The machine may be stopped at any time during the cycle by pressing the red **STOP** pushbutton on the control cabinet. The green light will go off on the green **START** pushbutton, the power is removed from the idle pump circuit but the heaters and fill remain on. To restart, push the green **START** pushbutton to reset the automatic cycle. Insert another loaded rack to start the idle pump switches. When the rack that was inside of machine has exited, reinsert that rack back into machine to make sure that the complete sanitation cycle of the original rack has been completed.

OPERATION (CONT')

13. The machine may also be stopped at any time during the cycle if the door(s) are raised. When the door is raised the light on the green **START** pushbutton goes off. The power is removed from the idle pump switch and the heat circuit. To reset the unit, close the door(s) follow the same procedure as in step 12. Push the green **START** pushbutton to reset the automatic cycle. Insert another loaded rack to start the idle pump switches. When the rack that was inside of machine has exited, reinsert that rack back into machine to make sure that the complete sanitation cycle of the original rack has been completed.
14. **CLEAN** the scrap screens and scrap baskets (if necessary) and **REPLACE** the tank water after each meal period or every 2 hours of operation. Check the chemical supply.



CAUTION:

***DO NOT** allow racks to remain on unload dishtable. This could cause the conveyor to jam and may damage the machine. The installation of a table limit switch is highly recommended and will reduce the risk of damage.*



CAUTION:

***DO NOT** leave water in the tanks over night.*

MAINTENANCE

The efficiency and life of your machine is increased by regularly scheduled preventive maintenance. A well maintained machine gives better results and service.

The best maintenance you can provide is to keep your machine clean. Components that are not regularly cleaned and flushed will clog and become inoperative.

Intervals shown in the following schedules represent an average length of time between necessary maintenance. Maintenance intervals should be shortened whenever your machine is faced with abnormal working conditions, hard water, or multiple shift operations.

Maintenance Schedule

Cleaning

• Daily/Every 2 Hours of Operation

1. Turn power switch to **OFF**.
2. Pull drain lever(s) to drain water. Remove scrap screens and scrap baskets (internal and external ,if applicable). Clean inside of the tanks and flush with clean water. Back flush the scrap screens until clean. (See Figs 2 & 3)



**Figure 2-
Scrap Screen Removal**

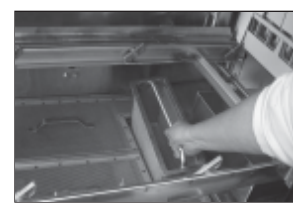

**Figure 3-
Scrap Basket Removal**



NOTE:

DO NOT strike or bang screens or baskets against solid objects

3. Remove the spray pipes (Figs. 4-6) Remove the end cap from each spray pipe (Fig. 7). Flush the pipes and nozzles until clean.



**Figure 4-
Unhooking Upper Arm**



**Figure 5-
Upper Wash Arm
Removal**



NOTE:

DO NOT strike or bang wash pipes against solid objects

Replace the end caps and verify the rubber o-rings are in place. Reinstall the spray pipes.

4. Remove and clean the curtains. Hang them off the dishtable and allow them to dry at the end of the day.
5. Leave the doors open between operations, allowing the machine to dry.
6. Verify that the final rinse nozzles are clean and free of any internal hard water deposits. If necessary, clean the nozzle orifices with a small paper clip. Consult your chemical supplier for proper use and the kind of deliming chemicals needed.
7. Report any unusual conditions to your supervisor.



**Figure 6-
Lower Wash Arm Removal**

• As Required

1. Check the temperature and pressure gauge readings
2. Inspect the machine and check the pump motor for any leaks around the shaft
3. Check the chemical supplies and refill as necessary.



**Figure 7-
End Cap Removal**

MAINTENANCE (CONT')

- **Weekly**

1. Inspect all water lines for leaks and tighten at joints if required.
2. Clean all of the detergent residue from the exterior of the machine.
3. Check the drain/overflow tube for any leaks,
4. Clean the accumulated scale from the heating element.
5. Remove and closely inspect each spray arm for blockage.
6. Straighten a small paper clip to clear each final rinse nozzle.
7. Inspect the pawl bar and drive assembly for wear and freedom of travel.
8. Check the float switch(es) in the tank(s) for freedom of travel.
9. Check the idle pump(s) and final rinse lever for freedom of travel.

Deliming

Your dishwasher should be delimed regularly as required. This will depend on the mineral content of your water.

Inspect your machines interior for lime deposits. If required, consult your chemical supplier for the proper type and procedures on deliming agents.

If you have a chemical sanitizing model 44 LT or 66 LT PW, **CAREFULLY** follow the procedure below before deliming:



DANGER:

Deliming solution, rinse agents or other acids must not come in contact with household bleach (sodium hypochlorite) or any chemicals containing chlorine, iodine, bromine, or fluorine. Mixing may cause hazardous gases to form. Consult your chemical supplier.

1. Remove the suction tube assembly from the bleach container and place it as close as possible to the floor. Place a catch pan underneath it.
2. Cycle the machine approximately six times to purge the lines of the bleach.
3. Proceed with the deliming procedures.

ELECTRICAL SERVICE

Fuse Blocks - 120VAC Control Voltage

Two fuse blocks, located in the center of the front of the main control cabinet, protect the main control transformer. Each fuse block holds one fuse. The fuses are marked 1FU and 2FU on the electrical schematic.

To replace the fuse:

- Disconnect the power to the machine at the main service switch.
- Remove the fuse and replace it.
- Turn the main power on.
- If the fuse blows again, **DO NOT INCREASE THE FUSE SIZE.**
- **DETERMINE THE CAUSE OF THE OVERLOAD.**



**Figure 8-
Fuse Blocks**

Fig. 5 shows the fuses and fuse blocks.

Motor Overloads

Motor overloads are located to the left of the fuse block inside the control cabinet. Each motor has one overload to protect it from line voltage electrical overloads. In addition, an auxiliary set of switch contacts is attached to the overload. The switch contacts disconnect 120VAC power to the motor contactor coils in the event of an overload condition. Refer to Fig.6.

Note the Switch Lever on the Overload

- If the red OFF switch lever is down with the “OFF” showing then the overload has tripped on an overload.

To Reset the Motor Overload:

- Push the start switch down with “ON” showing.
- Run the dishwasher and test the AMP draw of the motor in question. If the motor checks ok then there may be a wiring problem or the overload may be defective.

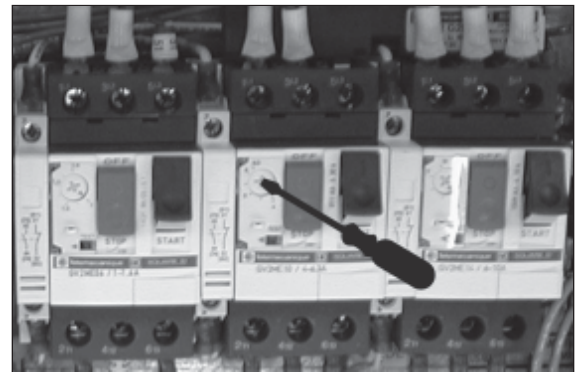

**Figure 9-
Motor Overload**

To Replace a Motor Overload:

- Disconnect the wires to the overload.
- Pull forward and lift out.
- Snap the new overload into place and reconnect the wires.

To Adjust the Overload Setting:

The screwdriver in Fig. 6 is positioned to adjust the motor overload AMP setting.

- Read the FLA motor amps that applies for the machine voltage on the Motor Nameplate.
- Flip up the plastic cover. Turn the setting to match the nameplate FLA.

ELECTRICAL SERVICE (CONT')

Pump Timer

The automatic timer located in the left center of the control cabinet is preset at the manufacturer.

The Pump Timer controls the amount of time that the pump(s) and the drive motor will run after the last rack enters the load end of the dishwasher tunnel.

The Pump Timer is an OFF DELAY timer. One timer controls all pumps no matter what the model it may be. Cycle time is 90 seconds.

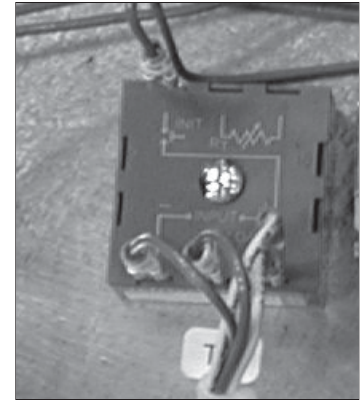

**Figure 10-
Pump Timer**

To Replace a Timer:

- Disconnect the power to the machine at the main service switch.
- Remove the wires connected to the timer. Remove the screw in the center of the timer.
- Remove the defective timer and install the replacement.
- Reinstall the screw and reinsert the wires.

Operation Sequence:

- A dishrack entering the machine contacts the idle pump switch lever.
- The contacts of the idle pump switch open, de-energizing control relay 1CR.
- Normally closed contacts of 1CR close and apply a signal to pump timer. The timer contacts close turning on the pump(s) and drive motor.
- The dishrack moves off the idle pump switch lever and the switch contacts close.
- 1CR energizes and the normally closed contacts open removing the signal from the pump timer.
- The pump timer begins to time down for its 90 seconds time setting.
- The timer is reset each time the idle pump switch is activated. If the timer is reset only once it will time out and shut the pump(s) and drive motor off after the time delay.

To Check the Pump Timer Setting:

Use a stop watch to check the timing cycle.

- Turn the power on.
- Press the green lighted START pushbutton.
- Place a rack in to the conveyer.
- When the rack enters the load end, the pump(s) and the drive motor will start.
- Start the stop watch when the rack clears the idle pump switch. Stop the stop watch when the machine stops. The length of the cycle should be 90 seconds +/- 2 seconds. If the timer is not within this range replace the timer.

ELECTRICAL SERVICE (CONT')

Automatic Fill/Low Water Heat Protection

Dual Float Switches

Each tank contains a dual float switch (see Fig.8). The device consists of an angled stem containing two reed switches. Two stainless steel ball floats, containing magnets, slide over the stem and are free to move up and down. When the float moves on the stem, it opens and closes the associated reed switch inside the stem. The reed switches control relays. The relays control the automatic fill and heat for different parts of the machine. The float switch(es) and their relay(s) operate on a 120V circuit.

Circuit Explanation

Refer to the electrical schematic on your machine for a detailed description of the individual float(s), relay(s) and wiring.



**Figure 11-
Dual Float Switch**

Bottom Float and Reed Switch

- The bottom float controls the heat.
- When the bottom float is down, the bottom reed switch contacts are open.
- When the bottom float is up, the bottom reed switch contacts are closed.

Top Float and Reed Switch

- The top float controls a fill valve, which controls the water level.
- When the top float is down, the top reed switch contacts are open.
- When the top float is up, the top reed switch contacts are closed.

Initial Fill

- When the tank is completely empty, both floats are down and their reed switch contacts are open.
- The control relay for the float switch is de-energized.
- The fill valve for the tank is energized and the tank begins to fill with water.
- As the water level in the tank rises, the bottom float begins to move up.
- When the bottom float is completely up, its reed switch contacts close.
- This prepares the heat circuit, but the heat **DOES NOT** energize at this time.
- The tank continues to fill until the top float is completely up.
- The top float's reed switch contacts close. Its control relay energizes.
- The fill valve de-energizes.
- The heat circuit energizes through the contacts of the control relay.

During Normal Operation

- If the water level in a tank falls below the level of the top float, the top float moves down and its reed switch contacts open.
- When the water level falls below the level of the bottom float, the bottom float moves down and its reed switch opens.
- The control relay de-energizes. The fill and rinse valve energizes and refills the tank.
- The heat circuit will de-energize until the water level in the tank raises the top float again.
- The bottom float keeps the heat circuit ready as long as the water level is above the level of the bottom float.

ELECTRICAL SERVICE (CONT')

Thermostat Locations and Adjustments

Electric tank heat is controlled by two thermostats.

1. The control thermostat which regulates the electric tank heat temperature.
2. The high limit thermostat which protects the tank from overheating.

Location

Both thermostats are located on the front of the tank, inside of a heater box enclosed in a stainless steel panel, behind the front access panel.

Adjustment

The Control Thermostat has an adjustment screw.

- The thermostat is wire Normally Closed.
- Turn the adjustment screw clockwise to increase the temperature in the tank and counterclockwise to decrease the temperature in the tank.

The High Limit Thermostat is not adjustable. It contains a red reset button on its center.

- The red button pops out if the temperature in the tank exceeds 210°F/99°C.
- Press the red button in to reset the high limit.

DETERMINE THE CAUSE OF THE HIGH TEMPERATURE CONDITION.

Refer to Fig 13 & Fig 14

Electric Booster Heat is controlled by two thermostats.

1. The control thermostat regulates the temperature.
2. The high limit thermostat protects the booster from overheating.
3. Each tank has a control and a high limit thermostat.

Location:

The control thermostat is in the junction box on the wash tank.

- The thermostat is wire Normally Closed.
- Turn the adjustment screw clockwise to increase the booster tank temperature and counterclockwise to decrease the booster tank temperature.

The high limit thermostat is also in the junction box on the wash tank.

- A red button that pops out when the temperature exceeds 210°F/99°C.
- Press the red reset button to reset the high limit.

Determine the cause of the high limit temperature condition.

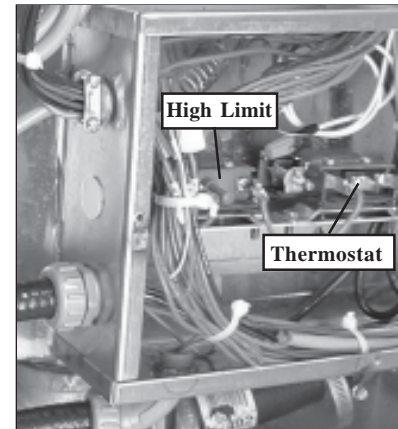

**Figure 12-
Tank Heat Thermostats**

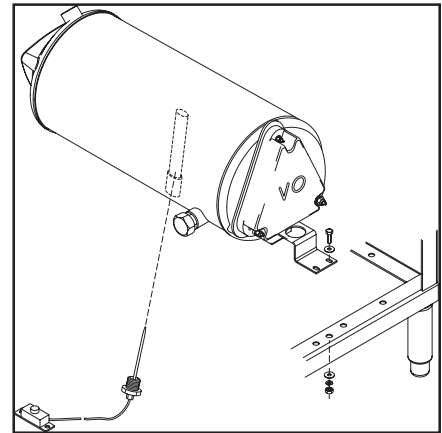

**Figure 13-
Booster Thermostat Location**

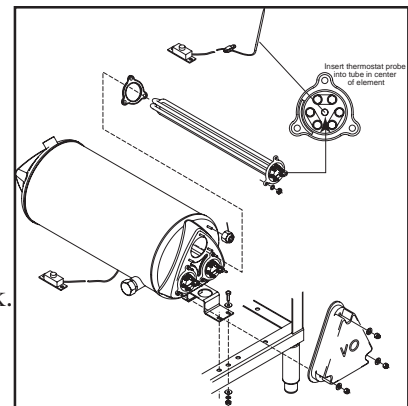

**Figure 14-
Booster High Limit Thermostat**

ELECTRICAL SERVICE (CONT')

Heater Element Wiring-Booster Tank and Wash Tank Heater Elements

Refer to the illustrations and follow the steps below to properly install terminal jumpers and to make line power connections to a replacement element.

- Step 1.** Hold the element assembly with the calrod coils facing toward you.
- Step 2.** Match your element coils to Configuration A or B
- Step 3.** Rotate your element coils to match the correct configuration.
- Step 4.** Flip the element over and match your element to the correct terminal configuration.
- Step 5.** Install the terminal jumpers according to the illustrations for your voltage requirement.
- Step 6.** Install the element and make your line connections 1L1, 1L2 or 1L3 per the illustration.
- Step 7.** If installing a booster element (that requires the limiting thermostat), the limiting thermostat should be inserted into the center of element. Thermostat should bottom out in the tube approximately 12" deep. The exposed capillary leads should be routed under the booster cover and fastened to the stud in the upper right side of the booster can with the clip and nut. See Figure 43 Electric Booster in Replacement Parts section.

Configuration A

Booster tank element
View of calrod coils

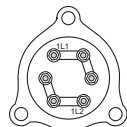

208V/1 Phase

Terminal Connections view of element

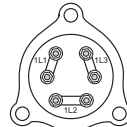

208-240V/3 Phase
Delta Connection

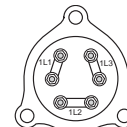

480V/3 Phase
575V/3 Phase
Delta Connection

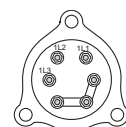

208-240V/3 Phase
Wye Connection for
380-415V/3 Phase

Configuration B

Wash tank element
View of calrod coils

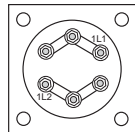
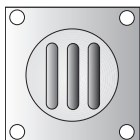

208V/1 Phase

Terminal Connections view of element

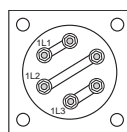

208-240V/3 Phase
Delta Connection

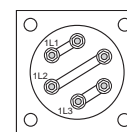

480V/3 Phase
575V/3 Phase
Delta Connection

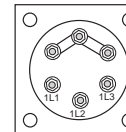

208-240V/3 Phase
Wye Connection for
380-415V/3 Phase

ELECTRICAL SERVICE (CONT')

Electric Booster Heater- Element Installation

Champion built-in boosters are constructed of stainless steel and have locations for three electric booster heater elements. There are three booster configurations for the rack conveyor models:

- 40°F/22°C rise booster (minimum of 140°F/60°C incoming water)
- 60°F/34°C rise booster (minimum of 120°F/49°C to 140°F/60° incoming water)
- 70°F/39°C rise booster (minimum of 110°F/43°C incoming water)

The canisters and total Kw ratings of the booster assemblies are determined by the model number of the machine and the minimum temperature of the incoming water supply that the end user is able to supply to the machine. Machines can be supplied with 40°F/22°C rise booster or 60°F/34°C rise booster which use only one canister (nested boosted) with separate electrical connections. The 70°F/39°C rise models use two canisters in the booster assemblies, these also have separate electrical connections.

Water Saver (44 WS and 66 WS PW) models are supplied in only 40°F/22°C or 70°/39°c rise booster assemblies. These are single canister units in either option and are not separate electrical connections.

ELECTRICAL SERVICE (CONT')

Motors-Pump

Voltage: Standard motors are multi-voltage
 Low voltage: 208-230VAC
 High voltage: 460VAC or 575VAC

Phase: Motors may be single or three phase.

Wiring Connections

Refer to the diagrams below for three phase motor lead wiring.

Low voltage 208-230V/3PH

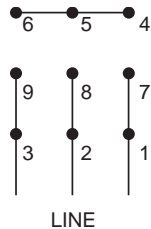

High voltage 460V/3PH

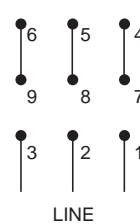

575V/3PH Only

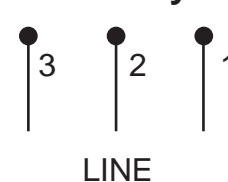

Refer to diagram at right for single phase motor lead wiring.

Low voltage 208-230V/1PH Only

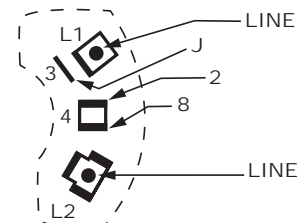

Troubleshooting

Motor will not run

1. Check incoming power to control cabinet.
2. Check for tripped manual motor starter (overload) in control cabinet.
(Refer to Motor Overload service section for proper settings).
3. Check power at motor contactor.

Motor runs hot and trips motor starter overload

1. Check for proper voltage between L1-L2 or (L1-L2, L2-L3, L1-L3 for 3 phase).
2. Check FLA on motor leads L1, L2, (also L3 for 3 phase) using amp tester.
(Motor full load amp (FLA) ratings are stamped on motor nameplate).

Motor Replacement

1. Disconnect the power to the machine.
2. Disconnect the wires to the motor junction box.
3. **Make note of the motor connections in order to phase the replacement correctly.**
4. Install the new motor and check for proper rotation.
(Proper rotation is clockwise looking from at the rear of the motor).
5. Motor rotation can be reversed by switching L1 and L2 on three phase motors.
Single phase motor rotation cannot be reversed.

ELECTRICAL SERVICE (CONT')

Motors-Drive

Voltage: Standard motors are multi-voltage
 Low Voltage: 208-240VAC 1 Phase Only
 High Voltage: 380/480/575VAC 3 Phase Only

208-240V 1Phase Wiring Diagram

To reverse motor rotation interchange yellow and orange leads.

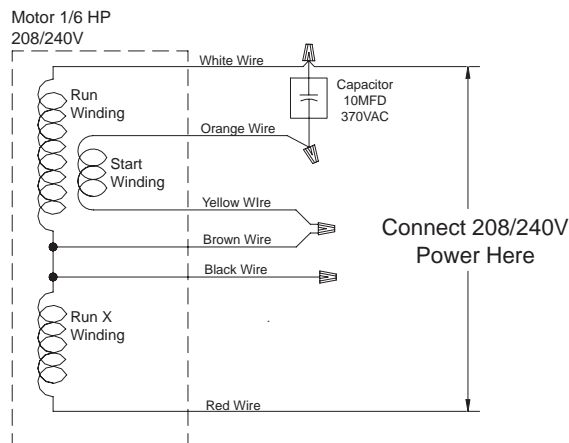

380/480/575V 3Phase Wiring Diagram

To reverse motor rotation interchange any two external connections.

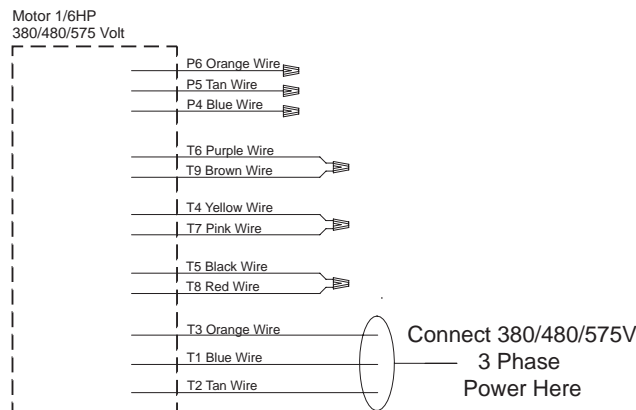

Drive Interlock Switch

Drive interlock will activate when a jam has occurred in the unit.

- When a jam occurs, the switch opens and the pump(s) and drive motor are then shut off, similar to the reaction of pushing the red **STOP** pushbutton (the green light goes out also).
- The switch will automatically reset when the jam is cleared. To restart/reset the machine push the green **START** pushbutton and insert a loaded rack.

REPLACEMENT PARTS

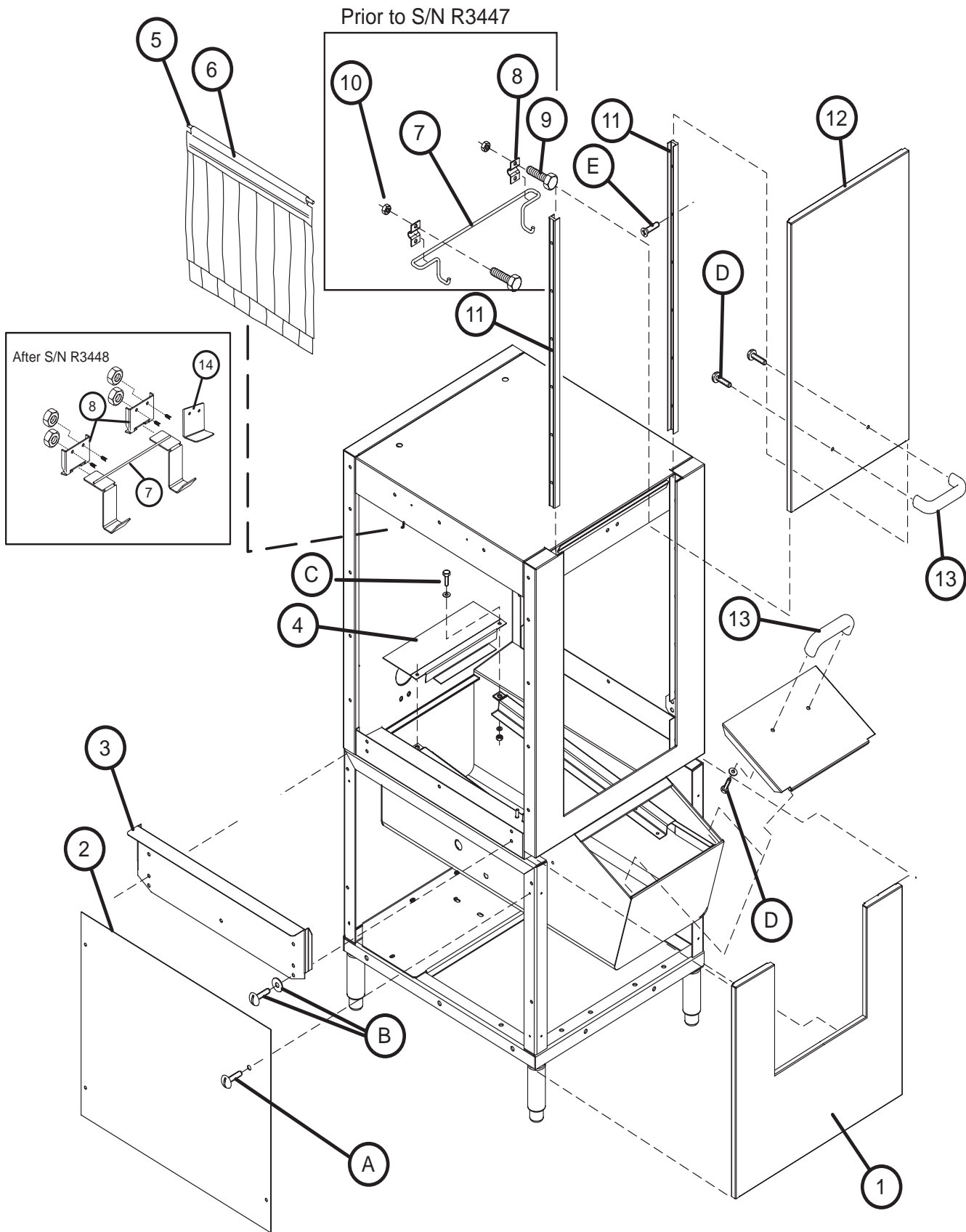

Figure 15- Prewash Panels, Doors and Miscellaneous

**PREWASH PANELS, DOORS
AND MISCELLANEOUS**

Fig. 15 Item No.	Part No.	Part Description	Qty
1	328977	Panel, Front Perimeter 22PW	1
1	328978	Panel, Front Perimeter 36PW	1
2	327857	Panel, 25" Prewash Perimeter	1
3	328030	Table Flange Support	1
4	328006	Support, 22 PW Rear Screen	1
5	108250	Rod Curtain 5/16 x 24-5/8	1
6	108043	Curtain 24 x 13-1/4	1
7	206358	Rod, 22PW Door Catch (Prior to S/N R3447)	1
7	328909	Door Catch 22PW (After S/N R3448)	1
8	327887	Bracket, Door Catch Mounting (Prior to S/N R3447)	2
8	317345	Bracket, Door Catch (After S/N R3448)	2
9	100734	Bolt, 1/4-20 x 1/2 Hex Head	2
10	100141	Nut, Grip 1/4-20 SST	2
11	113691	Guide, U-channel Door	2
12	327952	Door, 22PW	1
---	111026	Magnet, Door (Not Shown)	1
---	113719	Switch, Reed Aleph (Not Shown)	1
13	108966	Door Handle	2
14	313359	Bracket, Door Stop	1
A	Panel Fasteners (Qty per Panel)		
	100007	Screw 10-32 x 3/8 Truss Head	4
B	Table Flange Fasteners		
C	Screen Support Fasteners		
		Bolt	
		Washer	
		Nut	
D	Door and Scrap Basket Handle Fasteners (Qty per Handle)		
	100073	Screw 1/4-20 x 1/2 Truss Head	2
E	Door Guide Fasteners (Qty per Guide)		
	113486	Screw 8-32 x 5/8 Flat Head SST	6
	112431	Rivnut 8/32 Steel Zinc Plated	6

Prior to S/N R3447

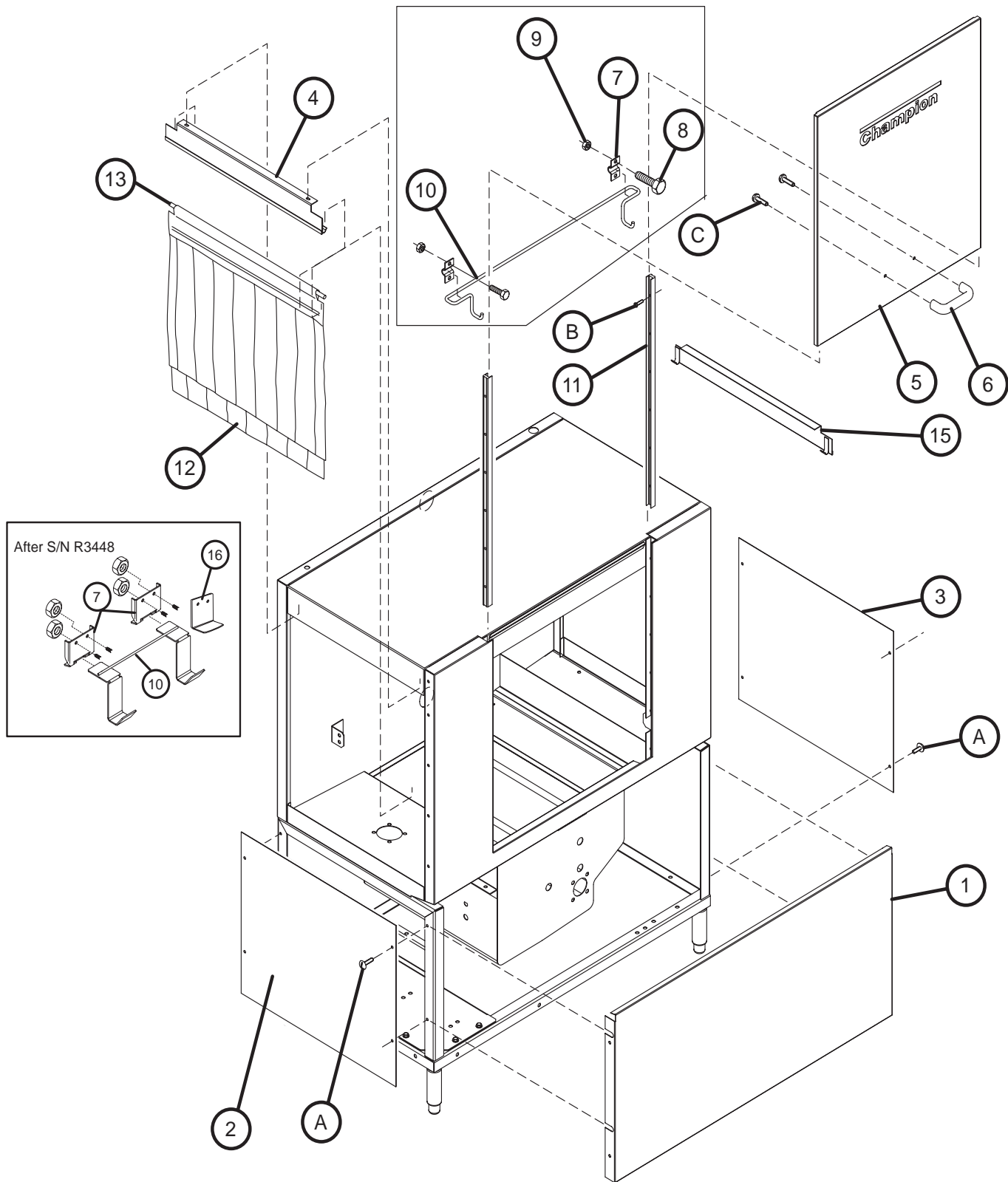

Figure 16- Single Tank Doors, Panels and Miscellaneous

**SINGLE TANK PANELS, DOORS
AND MISCELLANEOUS**

Fig. 15	Part	Part Description	Qty
Item No.	No.		
1	328974	Panel, 44 Front Perimeter	1
2	327889	Panel, 25" Side Perimeter (Load, L-R, No PreWash)	1
3	327889	Panel, 25" Side Perimeter (Unload, L-R No Booster)	1
4	327988	Entrance/Exit Curtain Baffle	2
5	327857	Door	1
---	111026	Magnet, Door (Not Shown)	1
---	113719	Switch, Reed Aleph (Not Shown)	1
6	108966	Door Handle	1
7	327887	Bracket, Door Catch Mounting (Prior to S/N R3447)	1
7	317345	Bracket, Door Catch (After S/N R3448)	2
8	100734	Bolt, 1/4-20 x 1/2 Hex Head	1
9	100141	Nut, Grip 1/4-20 SST	1
10	206305	Rod, Rack Door Catch (Prior to S/N R3447)	1
10	308133	Door Catch Dual Hook (After to S/N R3448)	1
11	113691	Guide, U-channel Door	2
12	113720	Curtain 24 x 20-1/4 4 Ply (Load and Unload)	2
13	108250	Rod, Curtain 5/16 x 24-5/8	3
14	109723	Curtain 24 x 6 -1/4 (Not shown)	1
15	328024	Curtain Baffle Rinse	1
16	313359	Bracket, Door Stop	1
A	Panel Fasteners (Qty per Panel)		
	100007	Screw 10-32 x 3/8 Truss Head	4
B	Door Guide Fasteners (Qty per Guide)		
	113486	Screw 8-32 x 5/8 Flat Head SST	6
	112431	Rivnut 8/32 Steel Zinc Plated	6
C	Door Handle Fasteners		
	100073	Screw 1/4-20 x 1/2 Truss Head	2

* Items 4 and 15 are welded into hood of machine.

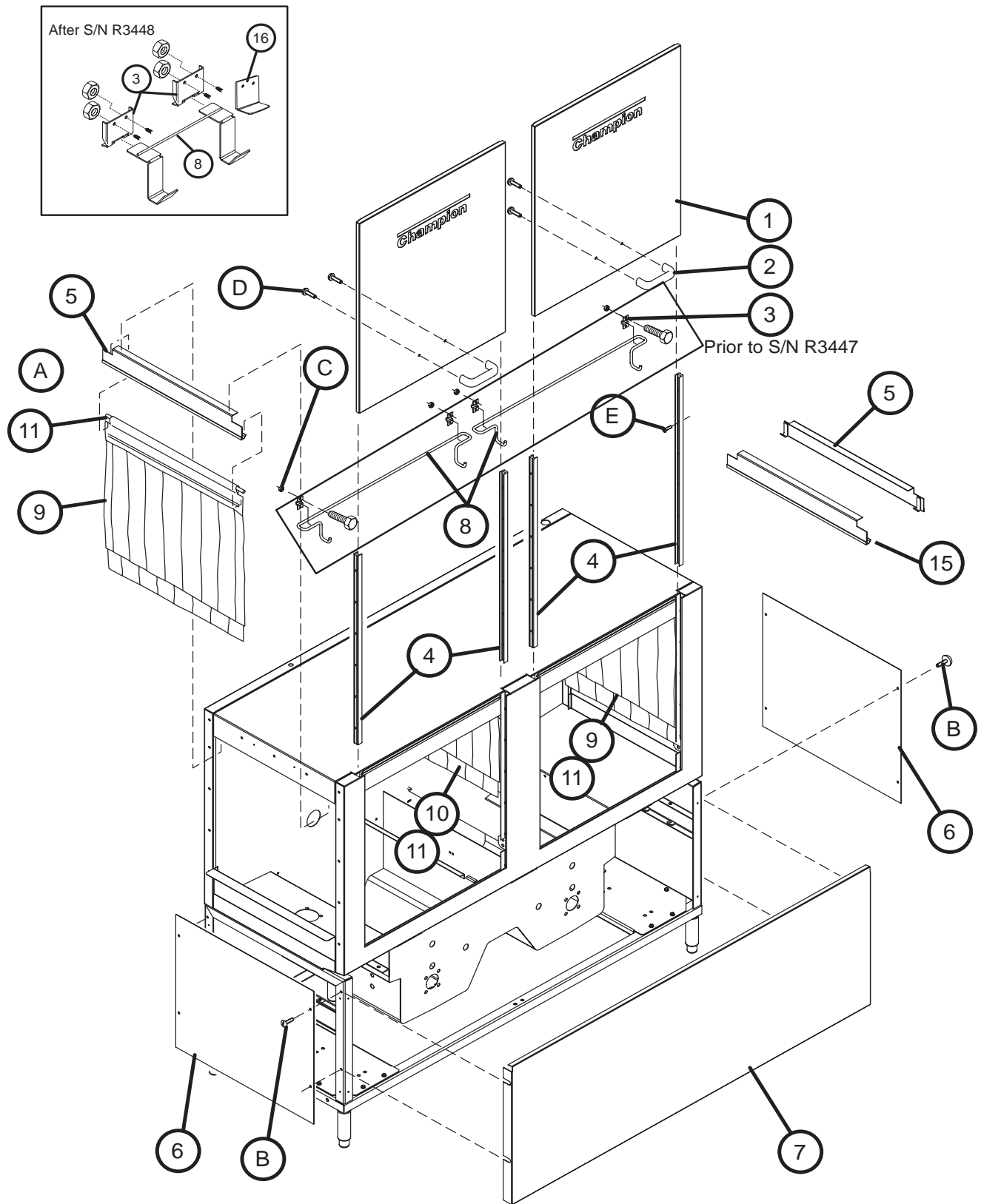

Figure 17- Two Tank Doors, Panels and Miscellaneous

**DOUBLE TANK PANELS, DOORS
AND MISCELLANEOUS**

Fig. 17 Item No.	Part No.	Part Description	Qty
1	414303	Door Assembly Wash (Includes Magnet, Switch and Item 2)	2
---	111026	Magnet, Door (Not Shown)	1
---	113719	Switch, Reed Aleph (Not Shown)	1
2	108966	Door Handle	2
3	327887	Bracket, Door Catch, Mounting (Prior to S/N R3447)	2
3	317345	Bracket, Door Catch (After S/N R3448)	4
4	113691	Guide, U-channel Door	4
5	328023	Baffle, Rack Curtain End	3
6	327889	Panel, 25" Side Perimeter (Load, No Prewash)	1
6	327889	Panel, 25" Side Perimeter (Unload, No Booster)	1
7	328975	Panel, 64 Front Perimeter	1
7	328976	Panel, 84 Front Perimeter Left Hand	1
7	328976-01	Panel, 84 Front Perimeter Right Hand	1
8	206305	Rod, Rack Door Catch (Prior to S/N R3447)	1
8	308133	Door Catch Dual Hook (After to S/N R3448)	2
9	113720	Curtain 24 x 20" 4 Ply (Load/Unload)	2
10	108043	Curtain 24 x 13-1/4" (Wash/Rinse)	1
11	108250	Rod, Curtain 5/16 x 24-5/8"	4
12	328030	Table Flange	2
13	109723	Curtain 24 x 6-1/4" (Rinse/Final Rinse)(Not Shown)	1
14	327851	Door (only) 44	A/R
15	328024	Center, Curtain Baffle (Not Shown)	1
16	313359	Bracket, Door Stop	2
A	Panel Fasteners (Qty per Panel)		
	100007	Screw 10-32 x 3/8 Truss Head	4
B	Door Guide Fasteners (Qty per Guide)		
	113486	Screw 8-32 x 5/8 Flat Head SST	6
	112431	Rivnut 8/32 Steel Zinc Plated	6
C	Door Handle Fasteners		
	100073	Screw 1/4-20 x 1/2 Truss Head	2

*** Items 5 and 15 are welded into hood of machine.**

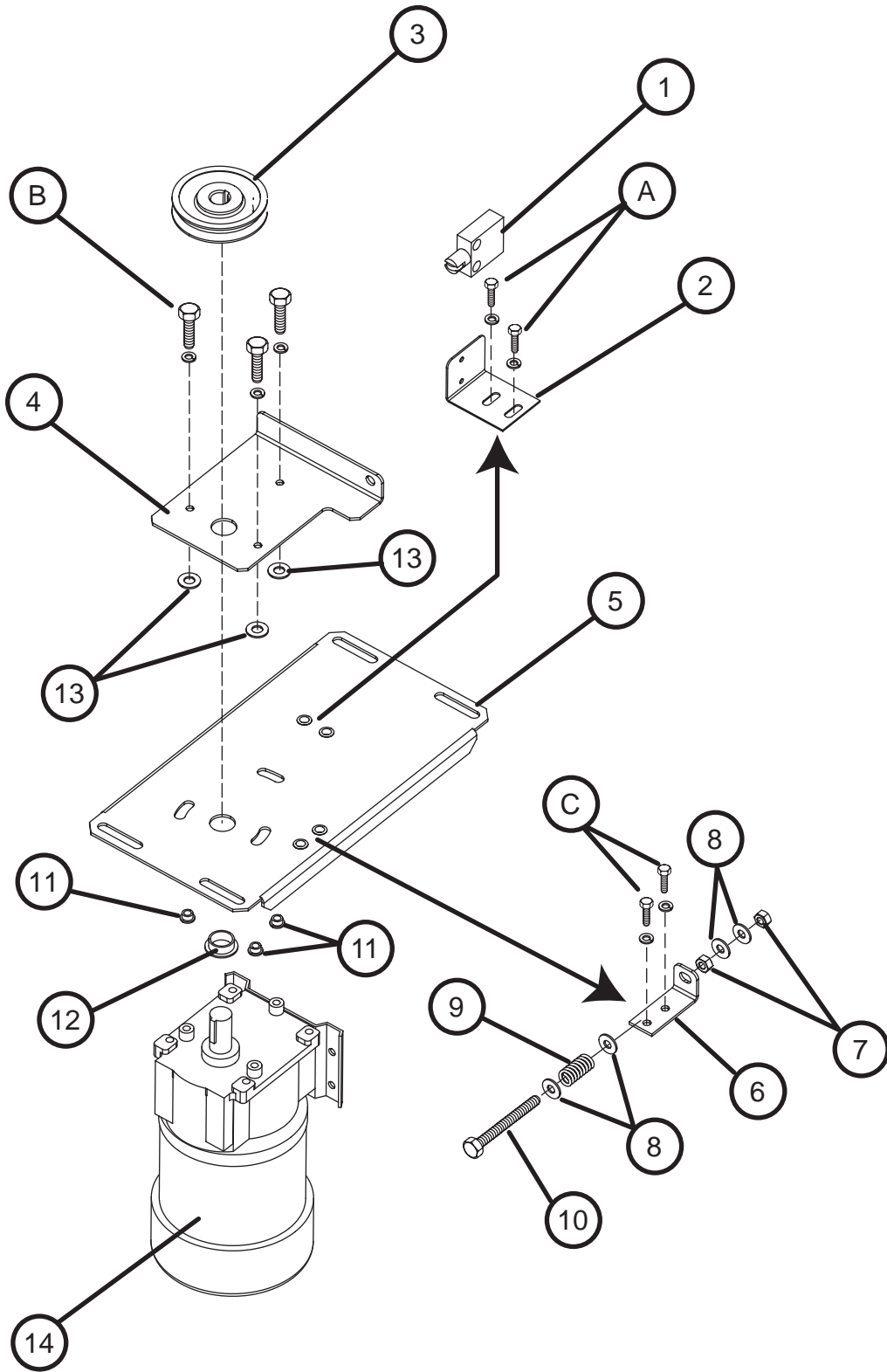

Figure 18- Drive Motor Assembly

DRIVE MOTOR ASSEMBLY

Fig. 18 Item No.	Part No.	Part Description	Qty
1	0509199	Drive Motor Switch	1
2	327918	Bracket, Motor Switch Mounting	1
3	103166	Sheave AK 39 5/8 Bore (44)	1
3	113893	Sheave AK 51 5/8 Bore (64)	1
4	327916	Plate, Drive Motor Mounting	1
5	327920	Plate, 44 Motor Assy Mounting	1
5	327917	Plate, 64 Motor Assy Mounting	1
6	327919	Bracket, Motor Spring Mounting	1
7	100154	Hex Nut Plain 5/16-18 SST	2
8	102376	Washer, Flat 5/16 x 3/4 x .06 SST	4
9	113702	Spring 0.6OD x 0.095 Wire x 1.5 Lg	1
10	113704	Screw, 5/16 x 3-1/2 Hex Head SST	1
11	113700	Bushing 3/8 x 3/4 x 1/16 Thrust Bronze	3
12	113703	Bushing, 3/4 x 7/8 x 3/8 x 1-1/8 Flg	1
13	113701	Bushing 1/4 x 3/8 x 1/2 x 1/16 Flg Bronze	1
14	113732	Motor, Gear 1/6HP 3PH	1
14	113679	Motor, Gear 1/6HP 1PH	1
A Switch Plate Fasteners			
	100734	Bolt 1/4-20 x 1/2 Hex Head SST	2
	106482	Washer Lock 1/4 Split	2
	112433	Rivnut, 1/4-20 Steel	2
B Drive Motor Mounting Plate Fasteners			
	100736	Bolt 1/4-20 x 3/4 Hex Head	3
	106482	Washer Lock 1/4 Split	3
C Spring Bracket Fasteners			
	100734	Bolt 1/4-20 x 1/2 Hex Head SST	2
	106482	Washer Lock 1/4 Split	2
	112433	Rivnut, 1/4-20 Steel	

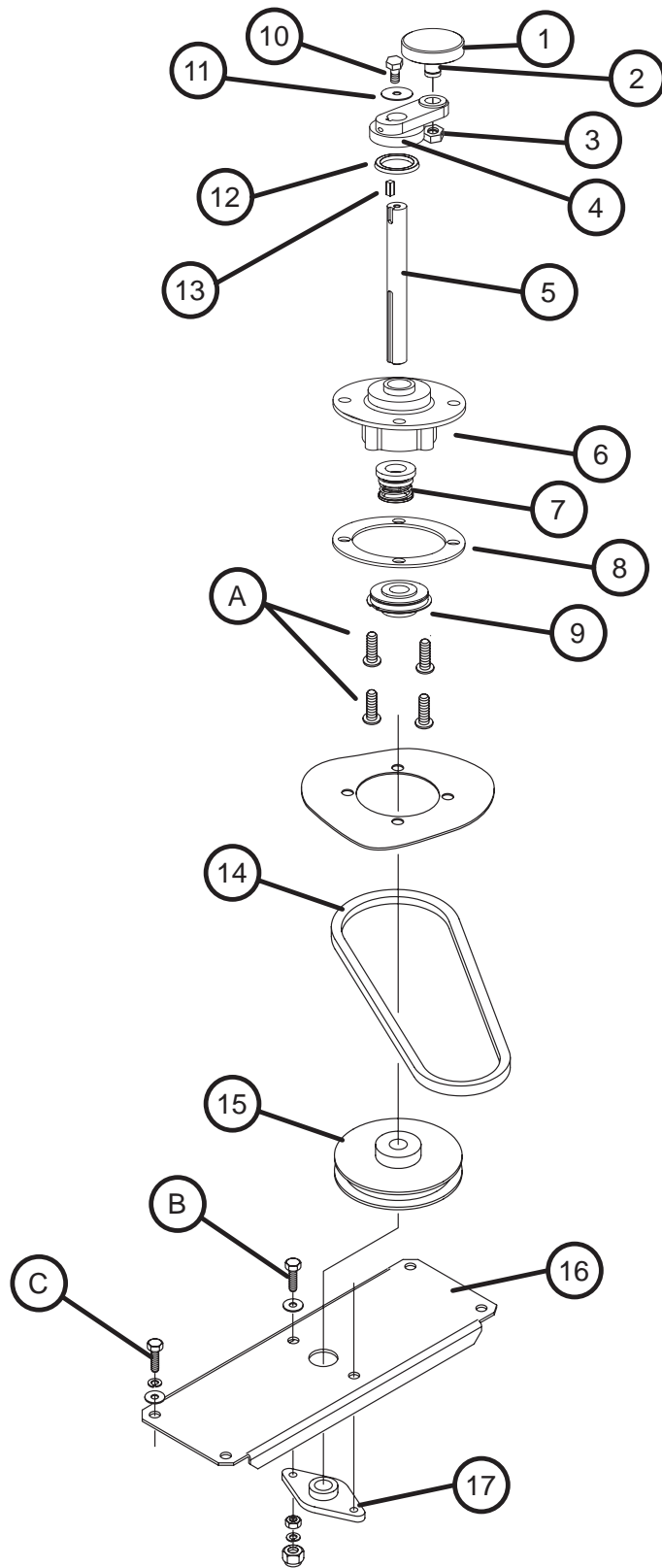

Figure 19- Drive Assembly

DRIVE ASSEMBLY

Fig. 19	Part		
Item No.	No.	Part Description	Qty
1	202381	Roller Crosshead	1
2	100868	Roller Stud Crosshead	1
3	107089	Nut Jam 1/2-13	1
4	206300	Crank, Rack Arm	1
5	206301	Shaft 5/8 Diameter 8-3/8 LG	1
6	206302	Housing, Bearing/Seal	1
7	102244	Seal 5/8"	1
8	206303	Gasket/Bearing Seal	1
9	100382	Bearing Jaf #EK104-10	1
10	100007	Screw, 10-32 x 3/8 Truss Head	1
11	104925	Washer 1/4 x 1 x 16 Gauge	1
12	103180	Wiper Ring	1
13	104916	Key 3/16 x 3/16 x 3/4 SST	1
14	100794	V-belt 4L 310	1
15	113892	Sheave AK 59-5/8 Bore	1
16	327924	Bracket, 44 Drive Bearing Mounting	1
17	113860	Bearing, Sealed 5/8 Bore	1
A	Bearing Housing Fasteners		
	104923	Screw 1/4-20 x 3/8 Round Head	4
	Mounted to Inside of Tank		
	100153	Bolt 3/8-16 x 1 Hex Head	4
	104618	Washer 3/8 x 7/8 x 1/16 SST	4
	109010	Nut Grip 3/8 w/Nylon Insert	4
B	Bearing Fasteners		
	100739	Bolt 5/16-18 x 3/4 Hex Head SST	2
	100154	Nut Plain 5/16-18	2
	106013	Washer Lock 5/16 Split	2
	109009	Nut Grip 5/16 w/Nylon Insert	2
C	Drive Bearing Bracket Fasteners		
	100739	Bolt 5/16-18 x 3/4 Hex Head SST	4
	106013	Washer Lock 5/16-18 Split	4
	102376	Washer 5/16 x 3/4 x 1/16	4

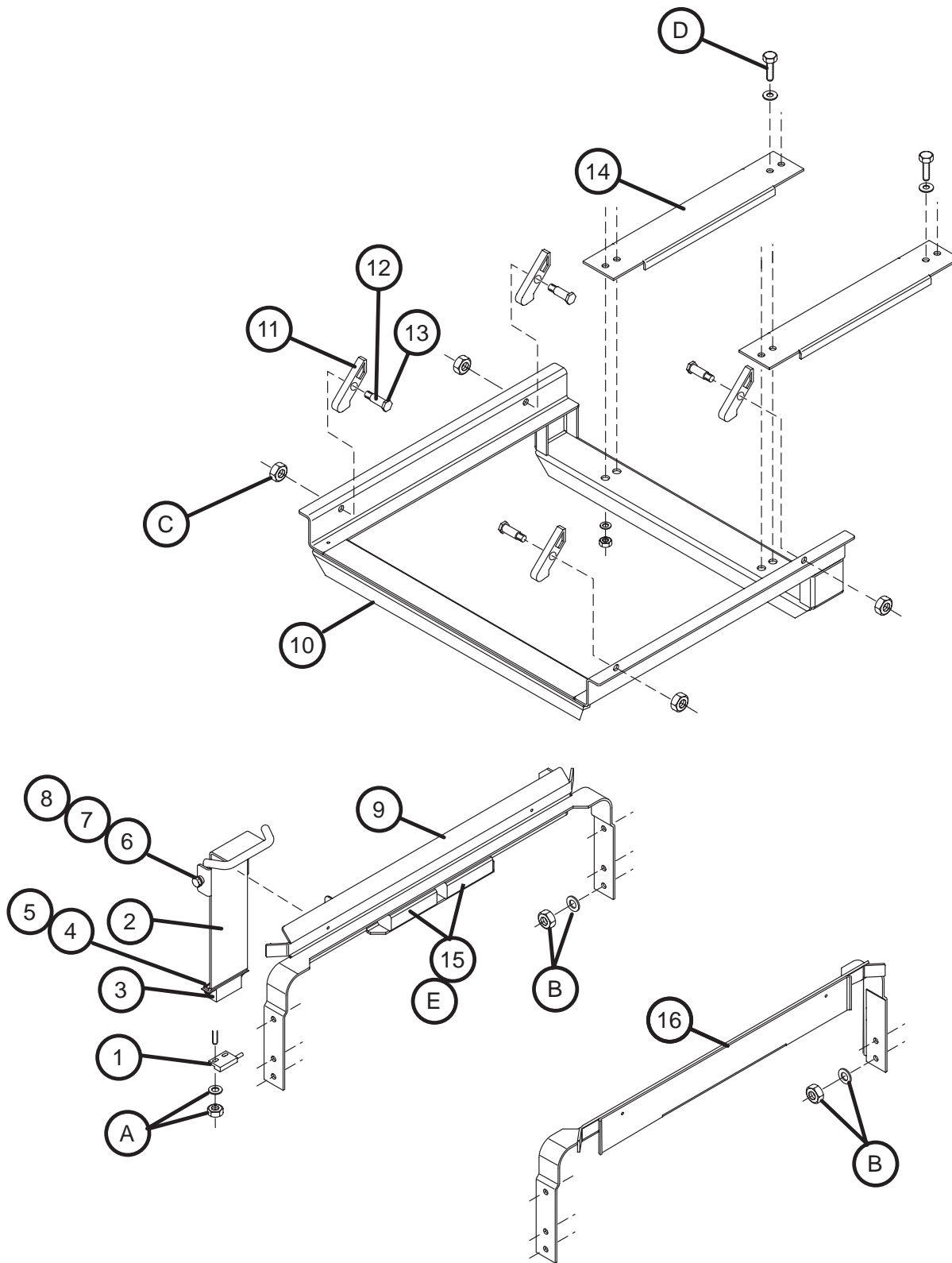

Figure 20- Prewash Track and Cradle Assembly

**PREWASH TRACK AND
CRADLE ASSEMBLY**

Fig. 20 Item No.	Part No.	Part Description	Qty
1	113719	Switch, Reed Aleph	1
2	328045	Switch, PW Idle	1
3	111026	Magnet, SS	1
4	100764	Screw, 6-32 x 1/2 Round Head SST	2
5	108954	Nut, Grip 6-32 Hex Head W/Nylon Insert	2
6	106482	Washer Lock 1/4 Split	2
7	327833	Pin Idle Pump Switch	1
8	100736	Screw, 1/4-20 x 3/4 Hex Head	2
9	328041	Track, 22" PW Rear	1
10	328043	Cradle, 22" PW	1
11	204513	Pawl, NG Cradle	4
12	206345	Bushing, Rack Cradle Pawl	4
13	113692	Screw, 3/8 x .875 x 5/15-18	4
14	328450	Bracket, Cradle bridge Single Tank/22PW	2
14	328613	Bracket, Cradle Bridge Two Tank/36PW	2
15	206343	Bearing, Rack Cradle Slide	4
16	327955	Track, 22" PW Front	1
B	Track Fasteners (Qty per Track)		
	112318	4
	100141	Nut, Grip 1/4-20	4
C	Pawl Fasteners (Qty per Pawl)		
	100142	Nut, Grip 5/16-18	1
E	Slide Bearing Fasteners (Qty per Slide)		
	100736	Bolt 1/4-20 x 3/4 Hex Head SST	2
	106482	Washer Lock 1/4-20 Split	2

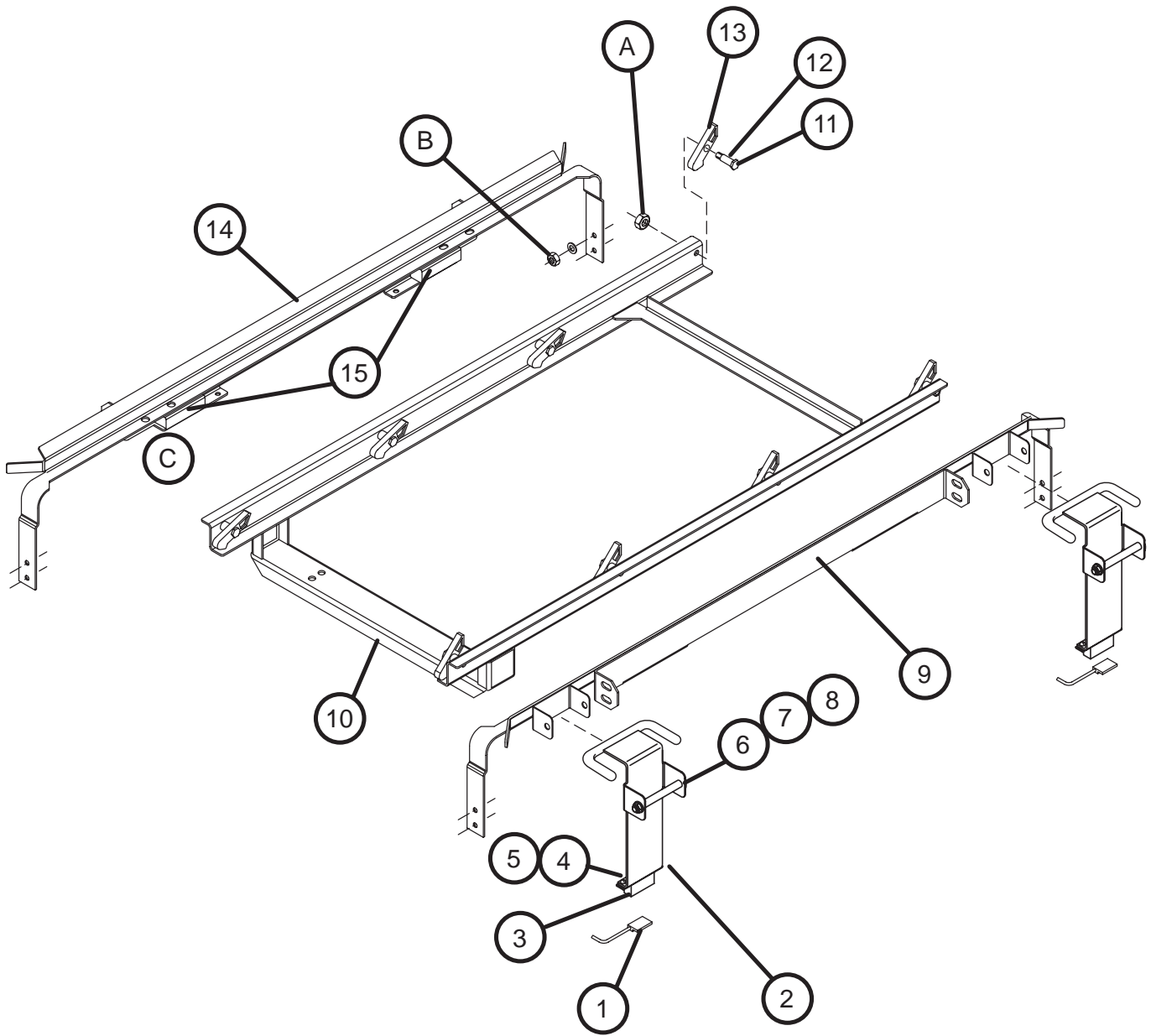

Figure 21- Single Tank Track and Cradle Assembly

**SINGLE TANK TRACK
AND CRADLE ASSEMBLY**

Fig. 21 Item No.	Part No.	Part Description	Qty
1	113719	Switch, Reed Aleph	1
2	414344	Switch, Idle Assembly (Includes Items 3-8)	1
3	111026	Magnet, SS	1
4	100764	Screw, 6-32 x 1/2 Round Head SST	2
5	108954	Nut, Grip 6-32 Hex Head W/Nylon Insert	2
6	106482	Washer Lock 1/4 Split	2
7	327833	Pin Idle Pump Switch	1
8	100736	Screw, 1/4-20 x 3/4 Hex Head	2
9	414370	Track, 44 Front	1
10	414307	Cradle, 44	1
11	113692	Screw, 3/8 x .875 x 5/15-18	8
12	206345	Bushing, Rack Cradle Pawl	8
13	204513	Pawl, NG Cradle	8
14	414357	Track, 44 Rear	1
15	206343	Bearing, Rack Cradle Slide	4
---	414377	Cradle, 44 Complete (Includes Items 10-13 and A)	A/R
A	Pawl Fasteners (Qty per Pawl)		
	100142	Nut, Grip 5/16-18	1
B	Track Fasteners (Qty per Track)		
	112318	4
	100141	Nut, Grip 1/4-20	4
C	Slide Bearing Fasteners (Qty per Slide)		
	100736	Bolt 1/4-20 x 3/4 Hex Head SST	2
	106482	Washer Lock 1/4-20 Split	2

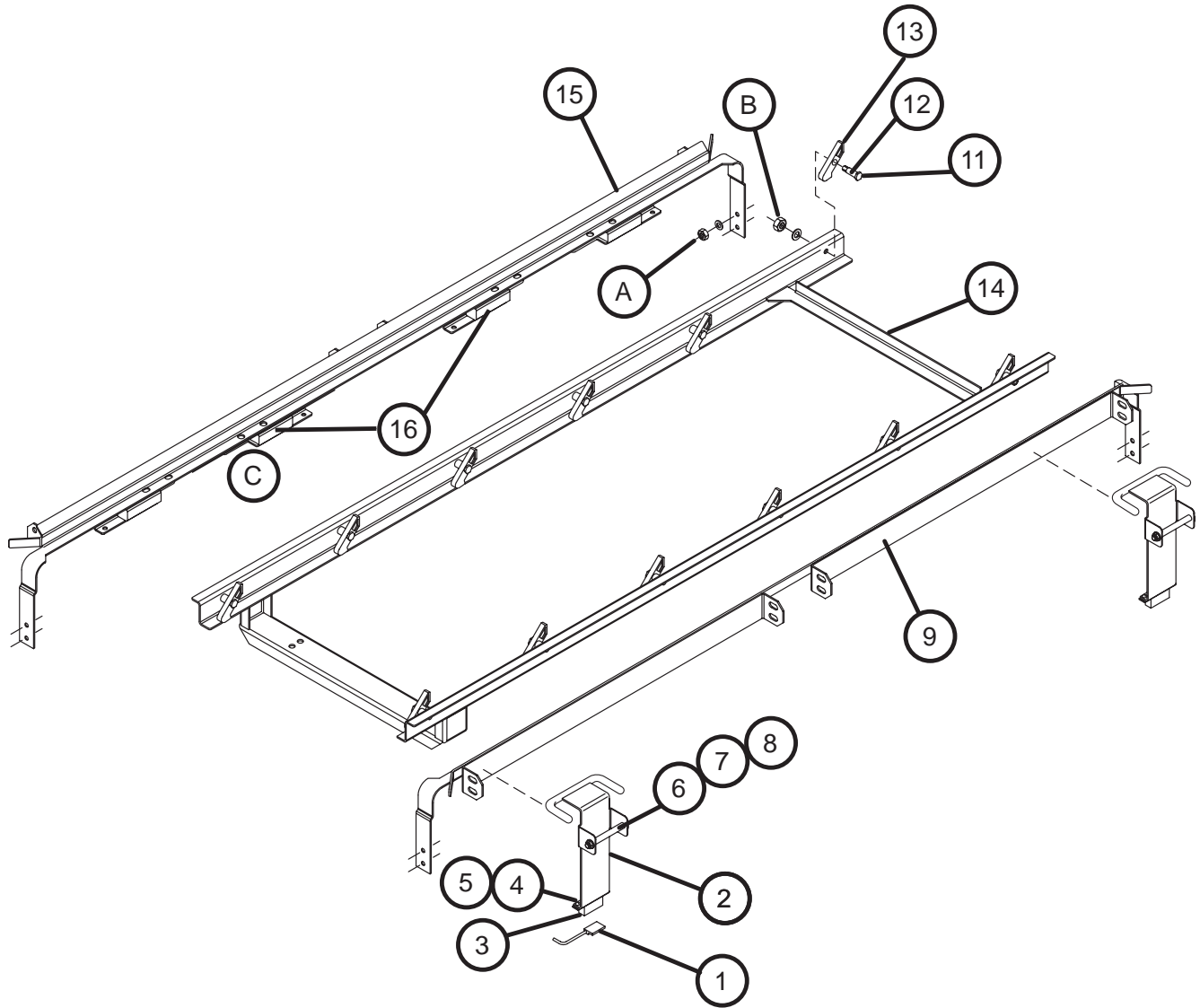

Figure 22- Two Tank Track and Cradle Assembly

**TWO TANK TRACK
AND CRADLE ASSEMBLY**

Fig. 22	Part	Part Description	Qty
Item No.	No.		
1	113719	Switch, Reed Aleph	1
2	414344	Switch, Idle Assembly (Includes Items 3-8)	1
3	111026	Magnet, SS	1
4	100764	Screw, 6-32 x 1/2 Round Head SST	2
5	108954	Nut, Grip 6-32 Hex Head W/Nylon Insert	2
6	106482	Washer Lock 1/4 Split	2
7	327833	Pin Idle Pump Switch	1
8	100736	Screw, 1/4-20 x 3/4 Hex Head	2
9	414372	Track, 64 Front	1
10	414378	Cradle, 64 Assembly (Includes Items 11-14)	1
11	113692	Screw, 3/8 x .875 x 5/15-18	12
12	206345	Bushing, Rack Cradle Pawl	12
13	204513	Pawl, NG Cradle	12
14	414308	Cradle, 64	1
15	414358	Track, 64 Rear	1
16	206343	Bearing, Rack Cradle Slide	8
A	Track Fasteners (Qty per Track)		
	112318	4
	100141	Nut, Grip 1/4-20	4
B	Pawl Fasteners (Qty per Pawl)		
	100142	Nut, Grip 5/16-18	1
C	Slide Bearing Fasteners (Qty per Slide)		
	100736	Bolt 1/4-20 x 3/4 Hex Head SST	2
	106482	Washer Lock 1/4-20 Split	2

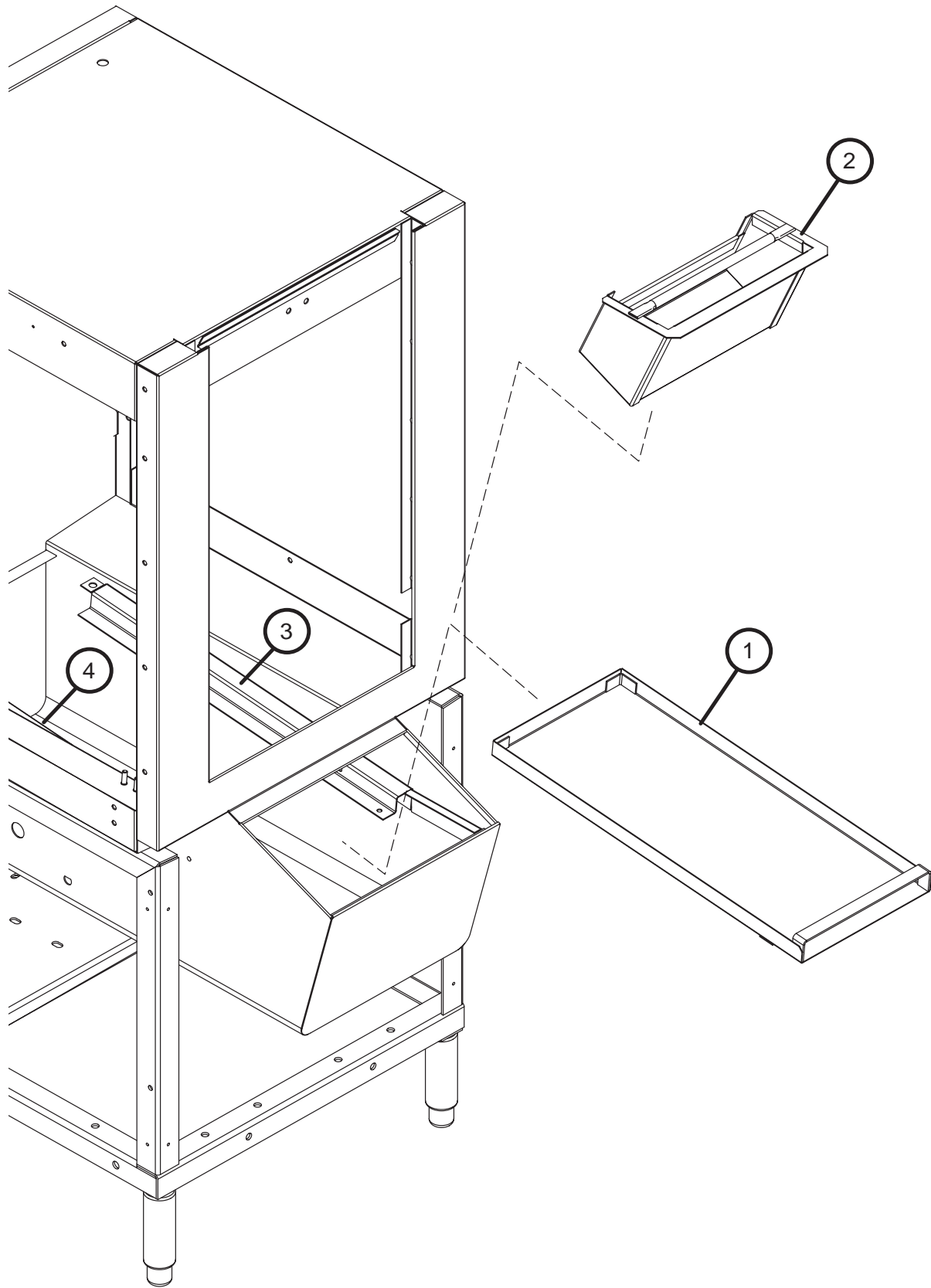

Figure 23- Prewash Screens

PREWASH SCRAP SCREENS

Fig. 23	Part		
Item No.	No.	Part Description	Qty
1	328958	Screen Assy	1
2	328959	Refuse Basket	1
3	328044	Support, PW RH Screen	1
4	328042	Support, PW LH Screen	1
5	328006	Support, PW Rear Screen (Not Shown).....	1

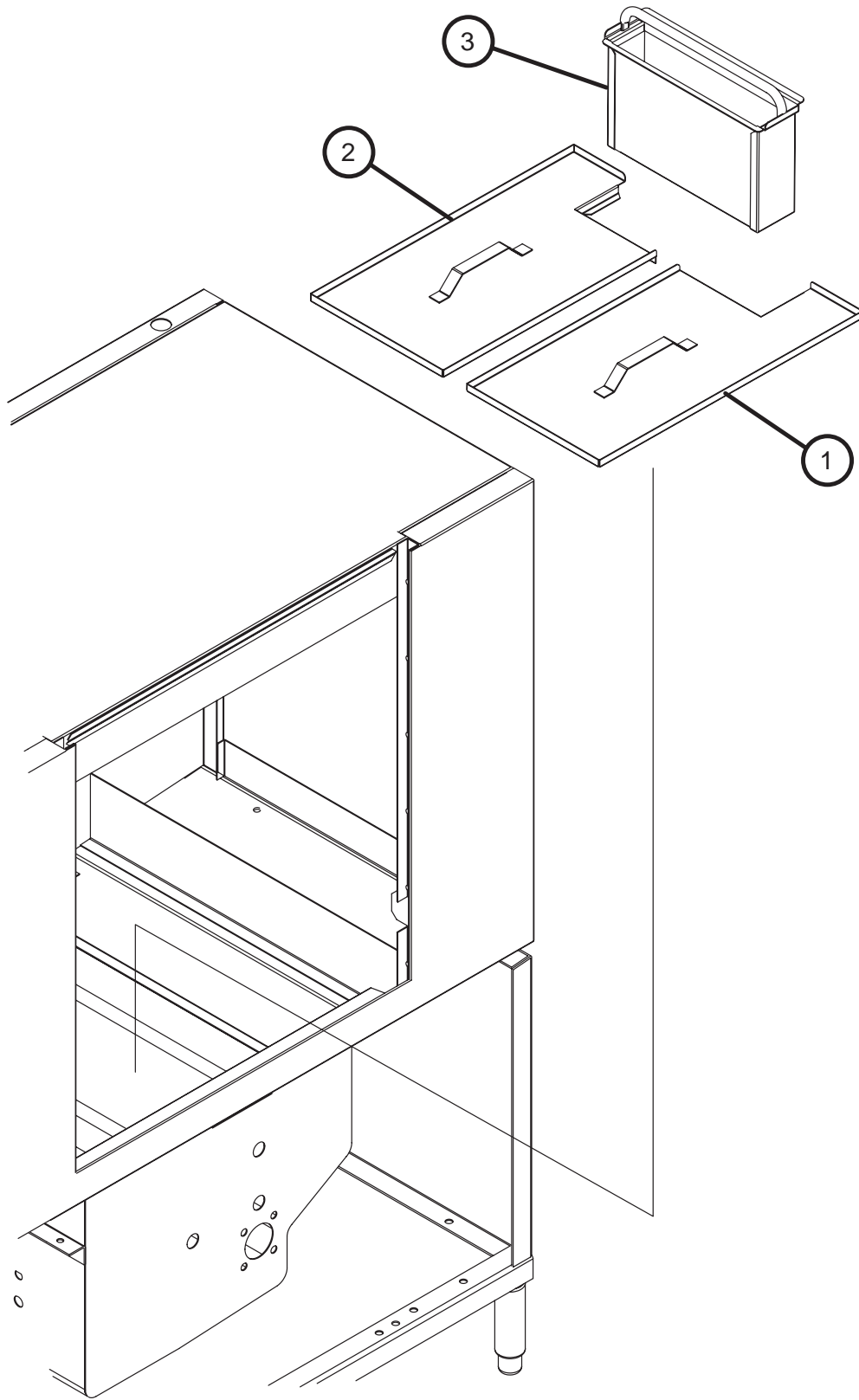

Figure 24- Single Tank Scrap Screens

SINGLE TANK SCRAP SCREENS

Fig. 24	Part		
Item No.	No.	Part Description	Qty
1	414328	Screen, 44 L-R Front	1
2	414329	Screen, 44 L-R Rear	1
3	414300	Basket, Rack	1
4	327888	Support, Screen Middle (Not Shown)	1

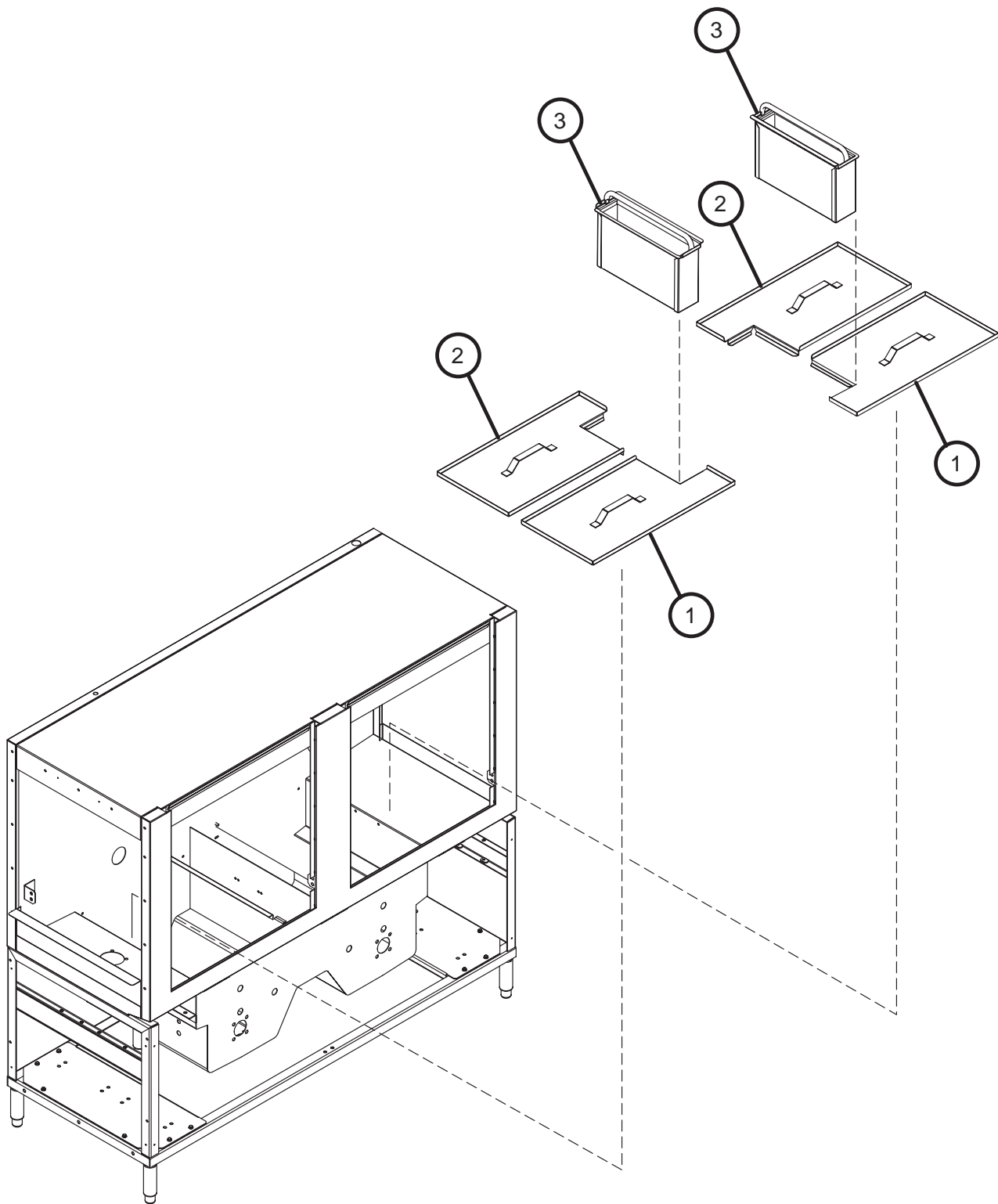

Figure 22 -Two Tank Scrap Screens

TWO TANK SCRAP SCREENS

Fig. 22	Part		
Item No.	No.	Part Description	Qty
1	414328	Screen, 44 L-R Front	1
2	414329	Screen, 44 L-R Rear	1
3	414300	Basket, Rack	1
4	327888	Support, Screen Middle (Not Shown)	1

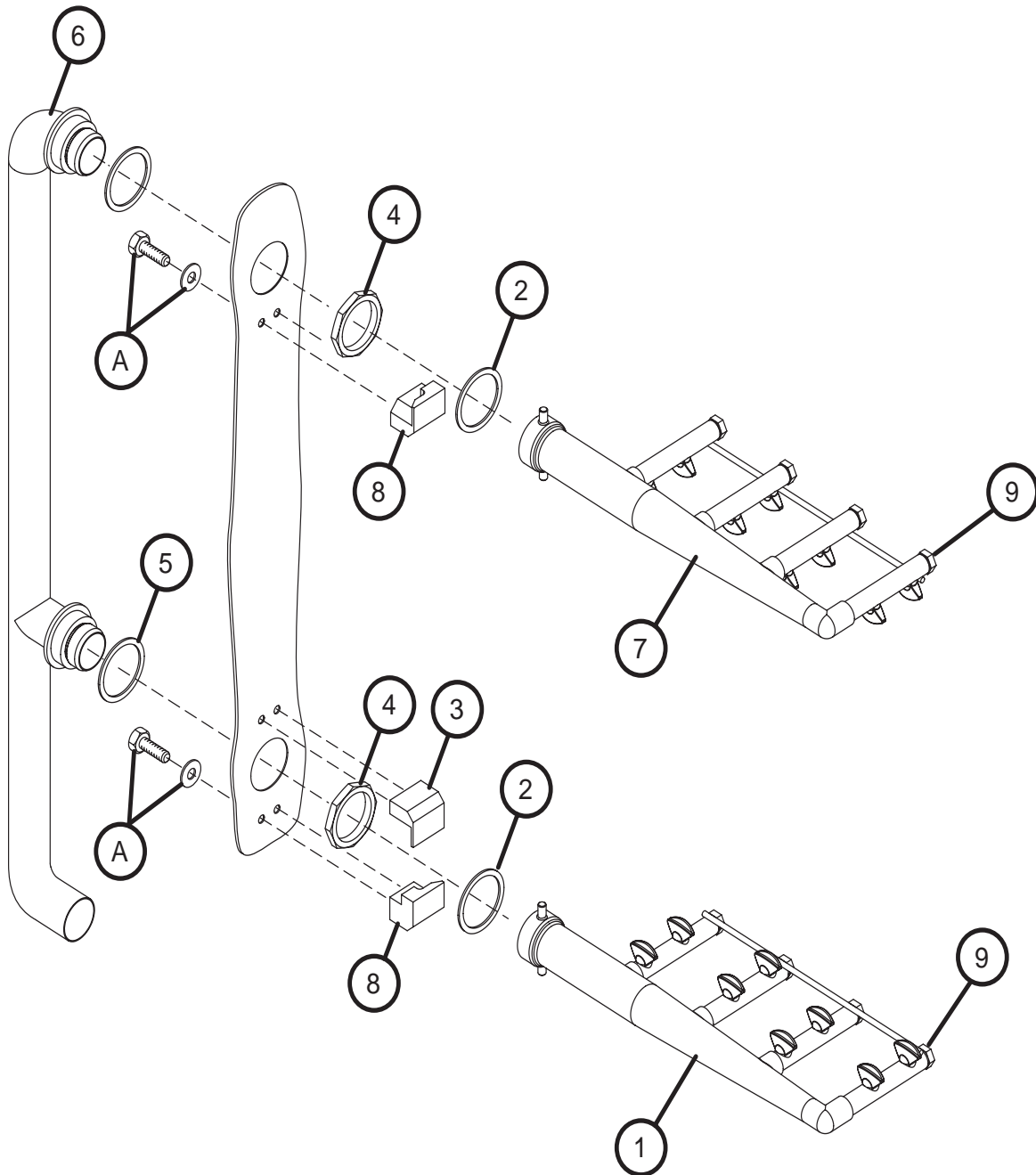

Figure 26- Prewash Spray Arms

PREWASH SPRAY ARMS

Fig. 26	Part		
Item No.	No.	Part Description	Qty
1	414293	Wash Manifold Assembly 6" Lower (Includes Item 9).....	1
2	113723	O-ring,1.75 ID	1
3	206355	Lock, CW Wash Pin	4
4	113540	Locknut 2NPT SST	2
5	113542	Gasket, Flat EDPM 2-3/8 ID	2
6	328028	Standpipe, 22" PW	1
7	414292	Wash Manifold Assy 6" Upper.....	1
8	206354	Lock, CCW Wash Pin	2
9	113555	Plug, Wash Arm E-Series (qty per arm) (Included in Item 1).....	4
A	Wash Arm Lock Fasteners (Qty per Arm)		
	100739	Bolt 5/16-18 x 3/4 Hex Head	4
	106013	Washer Lock 5/16 Split	4
	102376	Washer 5/16 x 3/4 x 1/16	4

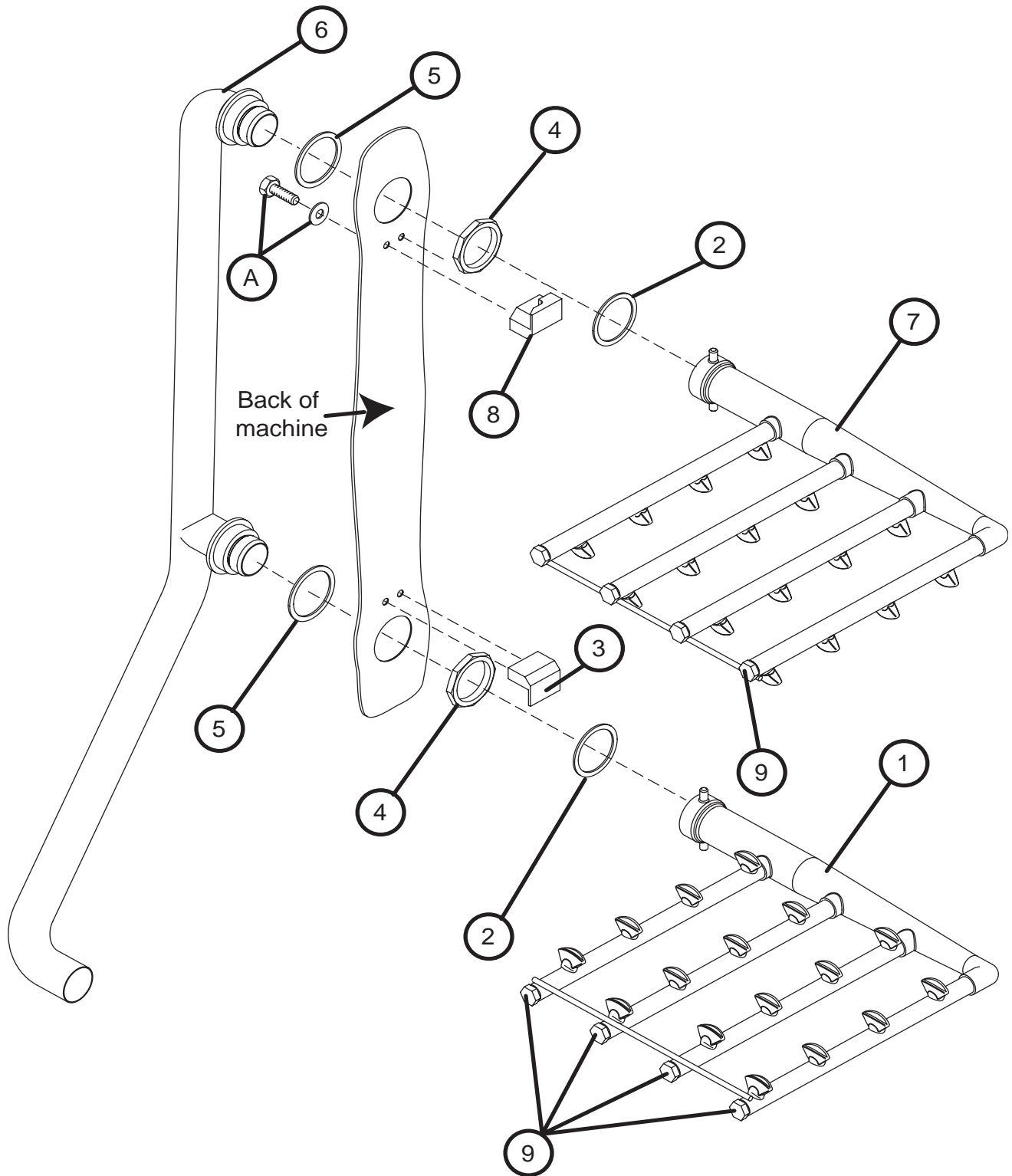

Figure 27- Single Tank Wash Arms
(Left to Right Shown)

SINGLE TANK WASH ARMS

Fig. 27	Part		
Item No.	No.	Part Description	Qty
1	414291	Wash Manifold Assembly 10" 15° Lower (L-R) (Includes Item 9)	1
1	414290	Wash Manifold Assembly 10" 15° Lower (R-L) (Includes Item 9)	1
2	113723	O-ring,1.75 ID	2
3	206354	Lock, CCW Wash Pin	1
4	113540	Locknut 2NPT SST	2
5	113542	Gasket, Flat EDPM 2-3/8 ID	2
6	414317	Standpipe, L-R 44	1
6	327993	Standpipe, R-L 44	1
7	414289	Wash Manifold Assy 14" Straight Upper (L-R)	1
7	414288	Wash Manifold Assy 14" Straight Upper (R-L)	1
8	206355	Lock, CW Wash Pin	1
9	113555	Plug, Wash Arm E-Series (qty per arm)(Included In Items 1 & 2) ...	4
A	Wash Arm Lock Fasteners (Qty per Arm)		
	100739	Bolt 5/16-18 x 3/4 Hex Head	4
	106013	Washer Lock 5/16 Split	4
	102376	Washer 5/16 x 3/4 x 1/16	4

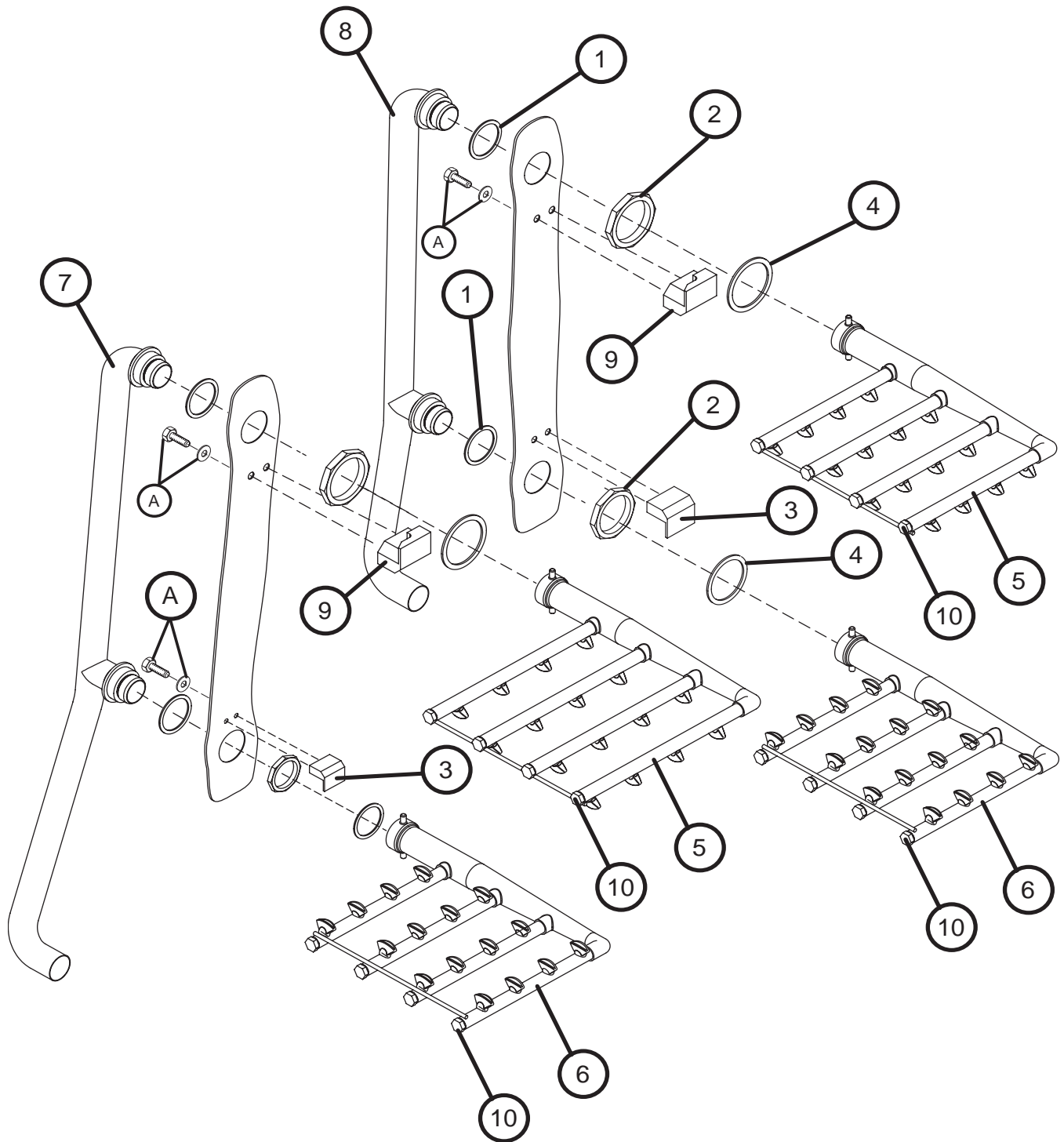

Figure 28- Two Tank Wash & Rinse Spray Arms
(Left to Right Shown)

TWO TANK WASH AND RINSE ARMS

Fig. 28	Part		
Item No.	No.	Part Description	Qty
1	113542	Gasket, Flat EDPM 2-3/8 ID	4
2	113540	Locknut 2NPT SST	4
3	206354	Lock, CCW Wash Pin	1
4	113723	O-ring, 1.75 ID	2
5	414289	Wash Manifold Assembly 14" Straight Upper (L-R)(Includes Item 9)	2
5	414288	Wash Manifold Assembly 14" Straight Upper (R-L)(Includes Item 9)	2
6	414291	Wash Manifold Assembly 10" 15° Lower (L-R)	2
6	414290	Wash Manifold Assembly 10" 15° Lower (R-L)	2
7	414318	Standpipe 64 L-R Wash	1
7	328443	Standpipe 64 R-L Wash	1
8	414319	Standpipe 64 L-R Rinse	1
	328445	Standpipe 64 R-L Rinse	1
9	206355	Lock, CW Wash Pin	2
10	113555	Plug, Wash Arm E-Series (qty per arm) (Included in Items 5 & 6)	4
A	Wash Arm Lock Fasteners (Qty per Arm)		
	100739	Bolt 5/16-18 x 3/4 Hex Head	4
	106013	Washer Lock 5/16 Split	4
	102376	Washer 5/16 x 3/4 x 1/16	4

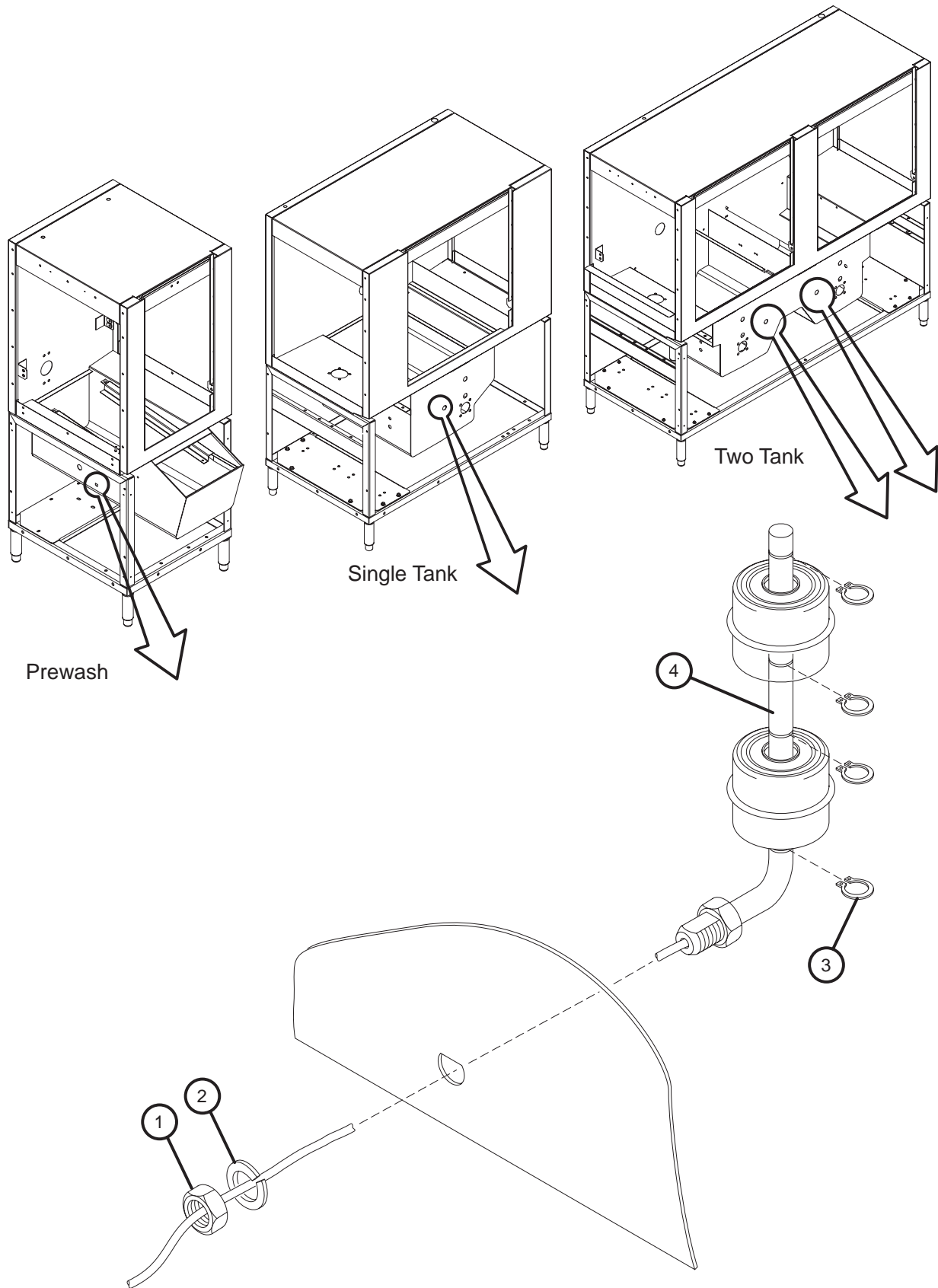

Figure 29- Float Switch

FLOAT SWITCH

Fig. 29	Part		
Item No.	No.	Part Description	Qty
1	104584	Nut, Plain 1/2-13	1
2	107589	Washer, Flat 1/2"	1
3	111151	C-Clip	A/R
4	110854	Float Switch Dual (Prewash)	1
	113291	Float Switch Dual W/R (44)	1
	113291	Float Switch Dual W/R (64)	2
--	110750	Gasket, Float Switch (Not Shown)	A/R

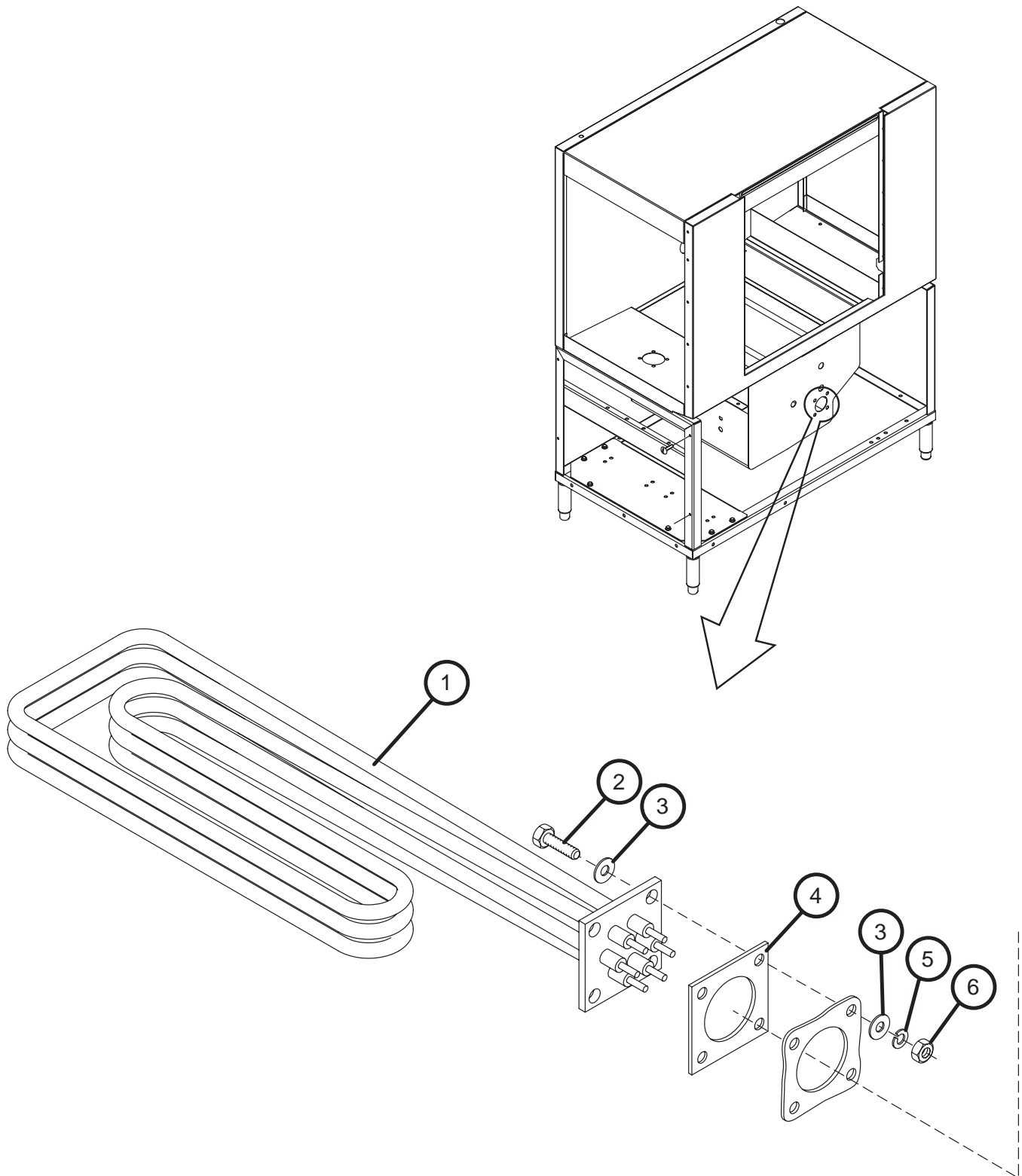

Figure 30- Single Tank Electric Heat

SINGLE TANK ELECTRIC HEAT

Fig. 30	Part		
Item No.	No.	Part Description	Qty
1	113516	Heater 15/18KW 208V,380V	1
	113517	Heater 15/16.3KW 230/240V, 400/415V	1
	113518	Heater 15/16.3KW 460/480V	1
	113519	Heater 15KW 575V	1
2	100153	Bolt, 3/18-16 x 1 Hex Head	4
3	104618	Washer 3/8 x 7/8 x 1/16 SST	8
4	108345	Gasket 3 x 3 x 1/8" 2" Hole	1
5	106407	Washer Lock 3/8 Split	4
6	100140	Nut Plain 3/8-16	4

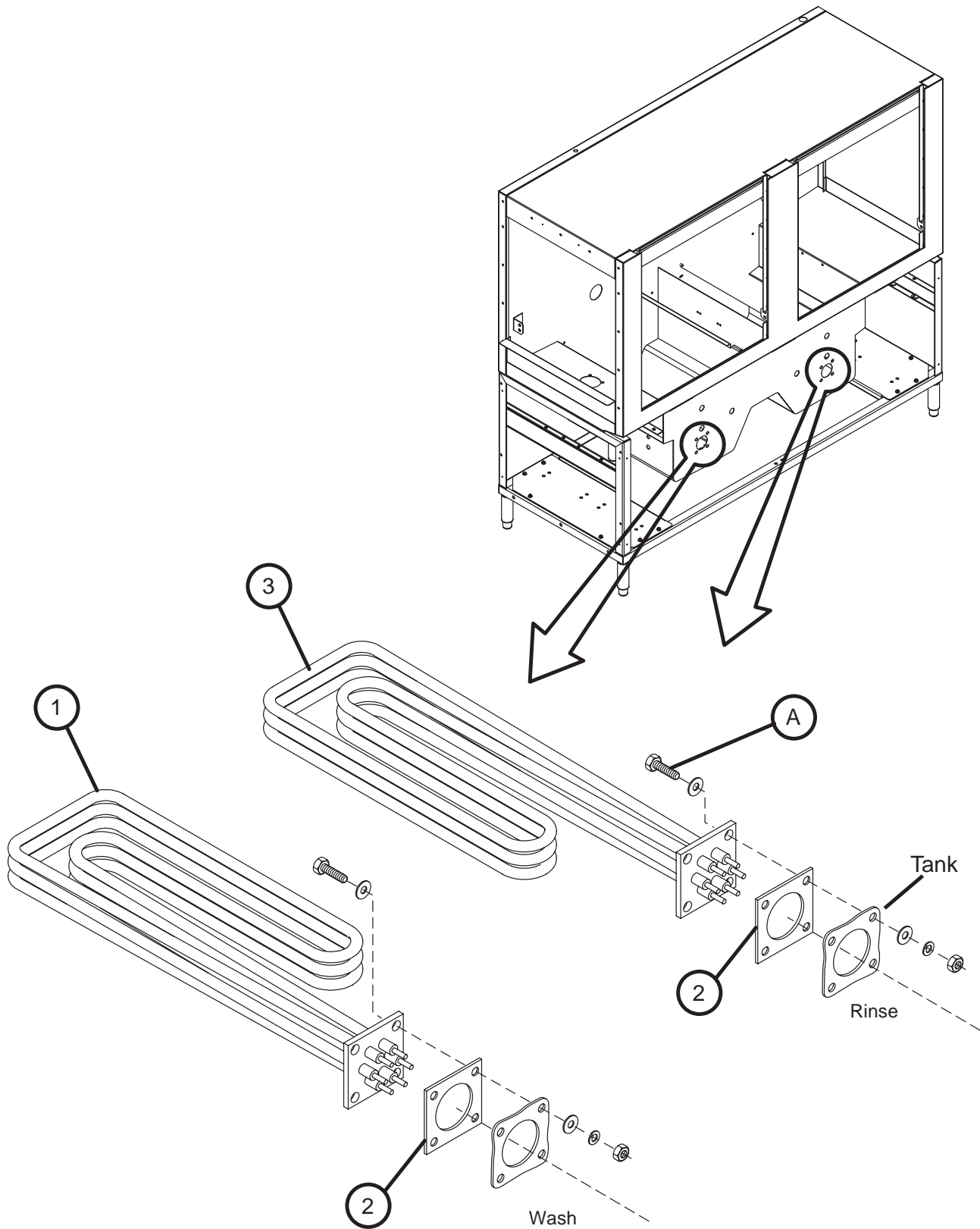

Figure 31- Two Tank Electric Heat

TWO TANK ELECTRIC HEAT

Fig. 31	Part		
Item No.	No.	Part Description	Qty
1	113516	Heater 15/18KW 200/220V (Wash)	1
	113517	Heater 15/16.3KW 230/240V(Wash)	1
	113518	Heater 15/16.3KW 460/480V (Wash)	1
	113519	Heater 15KW 575V (Wash)	1
2	108345	Gasket 3 x 3 x 1/8" 2" Hole	1
3	113804	Heater 10/12.1 KW 200/220V (Rinse)	1
	113882	Heater 10/11KW 230/240V (Rinse)	1
	113883	Heater 10/11KW 460/480V (Rinse)	1
	113884	Heater 10/11KW 575V (Rinse)	1
A	Element Fasteners (Qty Per Element)		
	100153	Bolt, 3/18-16 x 1 Hex Head	4
	104618	Washer 3/8 x 7/8 x 1/16 SST	8
	106407	Washer Lock 3/8 Split	4
	100140	Nut Plain 3/8-16	4

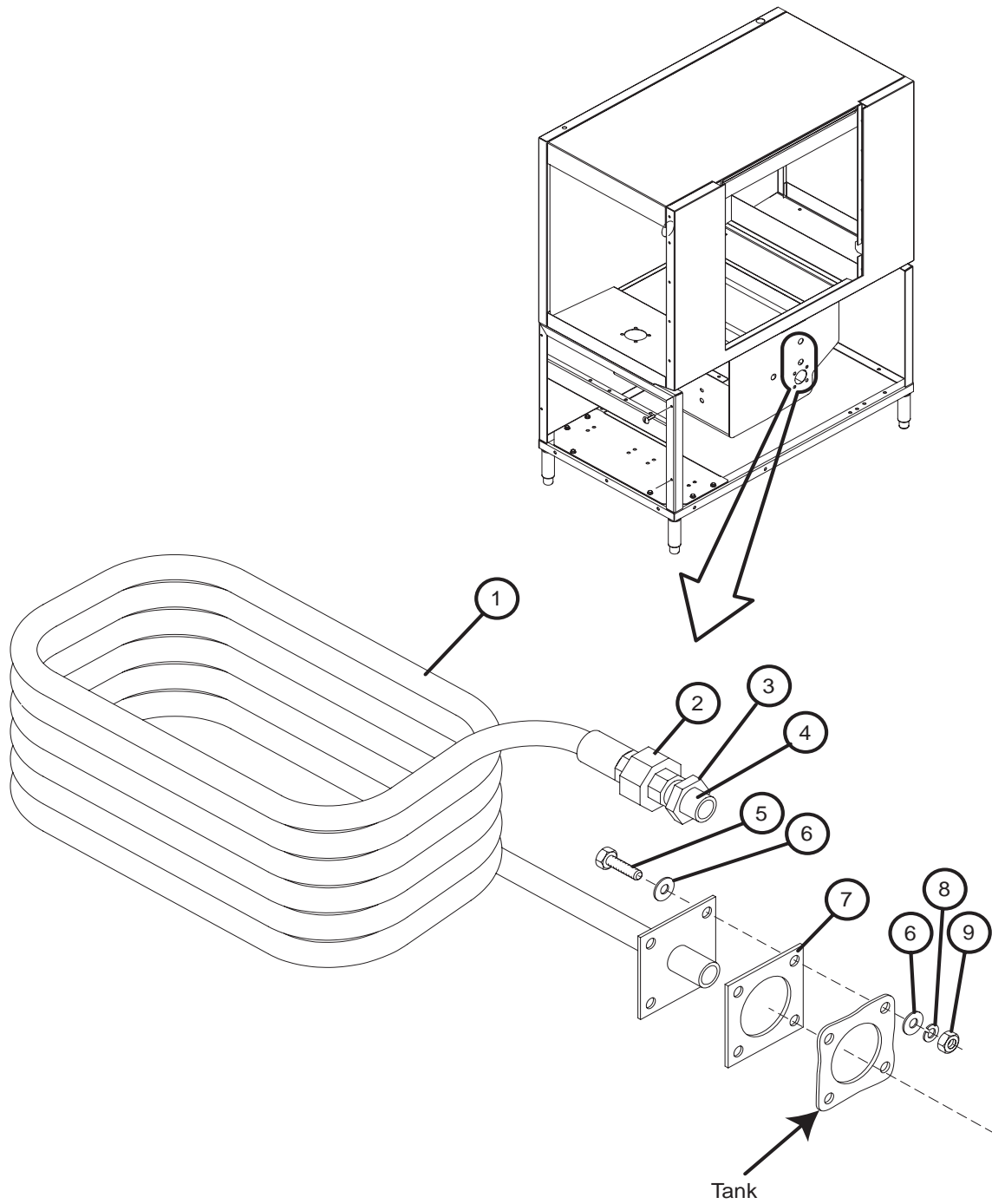

Figure 32- Single Tank Steam Heat

SINGLE TANK STEAM HEAT

Fig. 32	Part		
Item No.	No.	Part Description	Qty
1	327908	Coil, Steam RH (Shown)	1
1	327907	Coil, Steam LH	1
2	102554	Union 3/4 SST	1
3	100548	Locknut, 3/4NPT SST	1
4	113918	Nipple, Rtoe 3/4 x 1-3/4	1
5	100740	Bolt 5/16-18 x 1 Hex Head	4
6	102376	Washer 5/16 X 3/4 x 1/16	8
7	108345	Gasket 3 x 3 1/8" 2IN Hole	1
8	106013	Washer Lock 5/16 Split	4
9	100154	Nut Plain 5/16-18	4

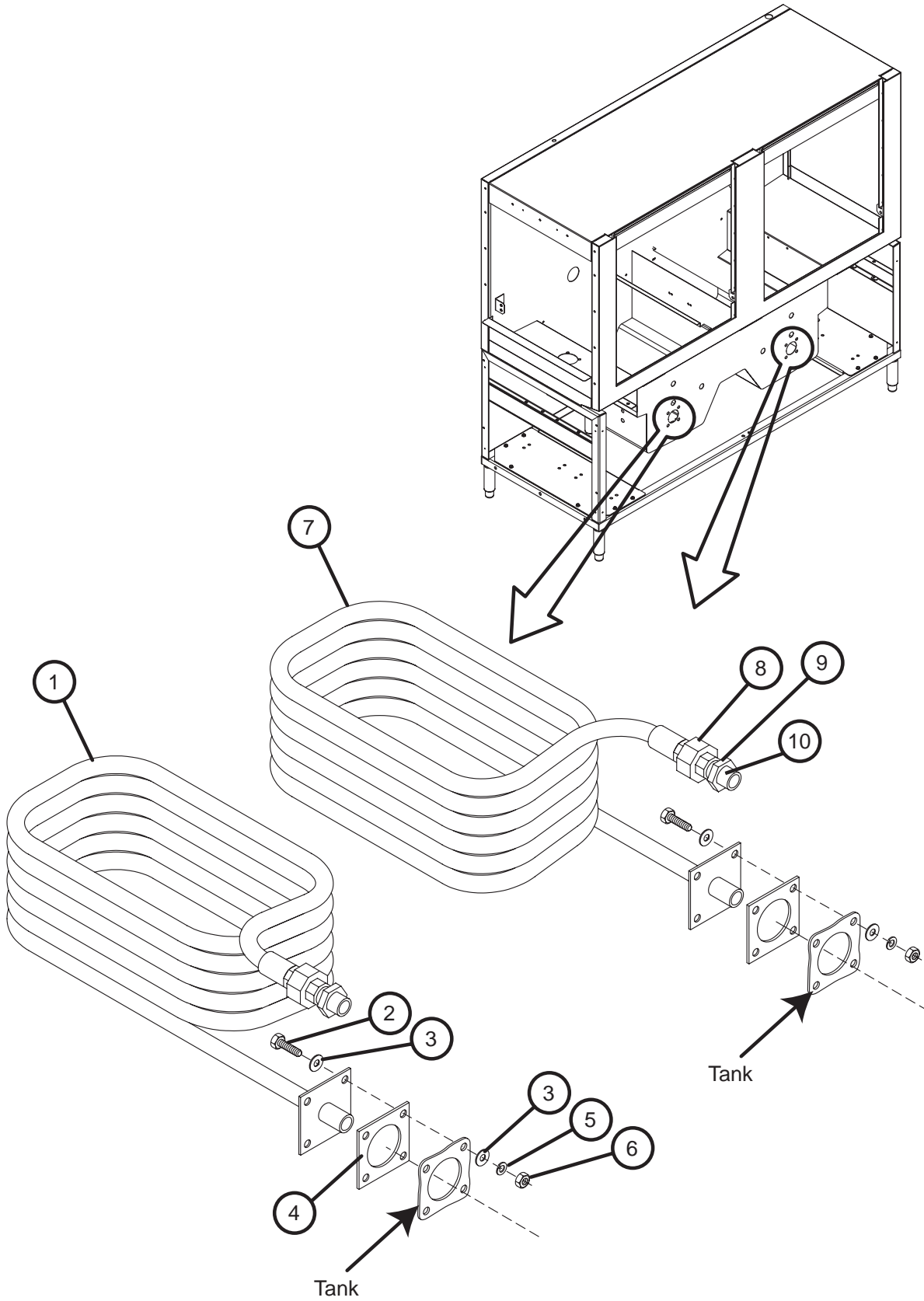

Figure 33- Two Tank Steam Heat

TWO TANK STEAM HEAT

Fig.33	Part		
Item No.	No.	Part Description	Qty
1	327907	Coil, Steam LH	1
2	100740	Bolt 5/16-18 x 1 Hex Head	8
3	102376	Washer 5/16 X 3/4 x 1/16	16
4	108345	Gasket 3 x 3 1/8" 2IN Hole	2
5	106013	Washer Lock 5/16 Split	8
6	100154	Nut Plain 5/16-18	8
7	327908	Coil, Steam RH	1
8	102554	Union 3/4 SST	2
9	100548	Locknut, 3/4NPT SST	2
10	113918	Nipple, Rtoe 3/4 x 1-3/4	2

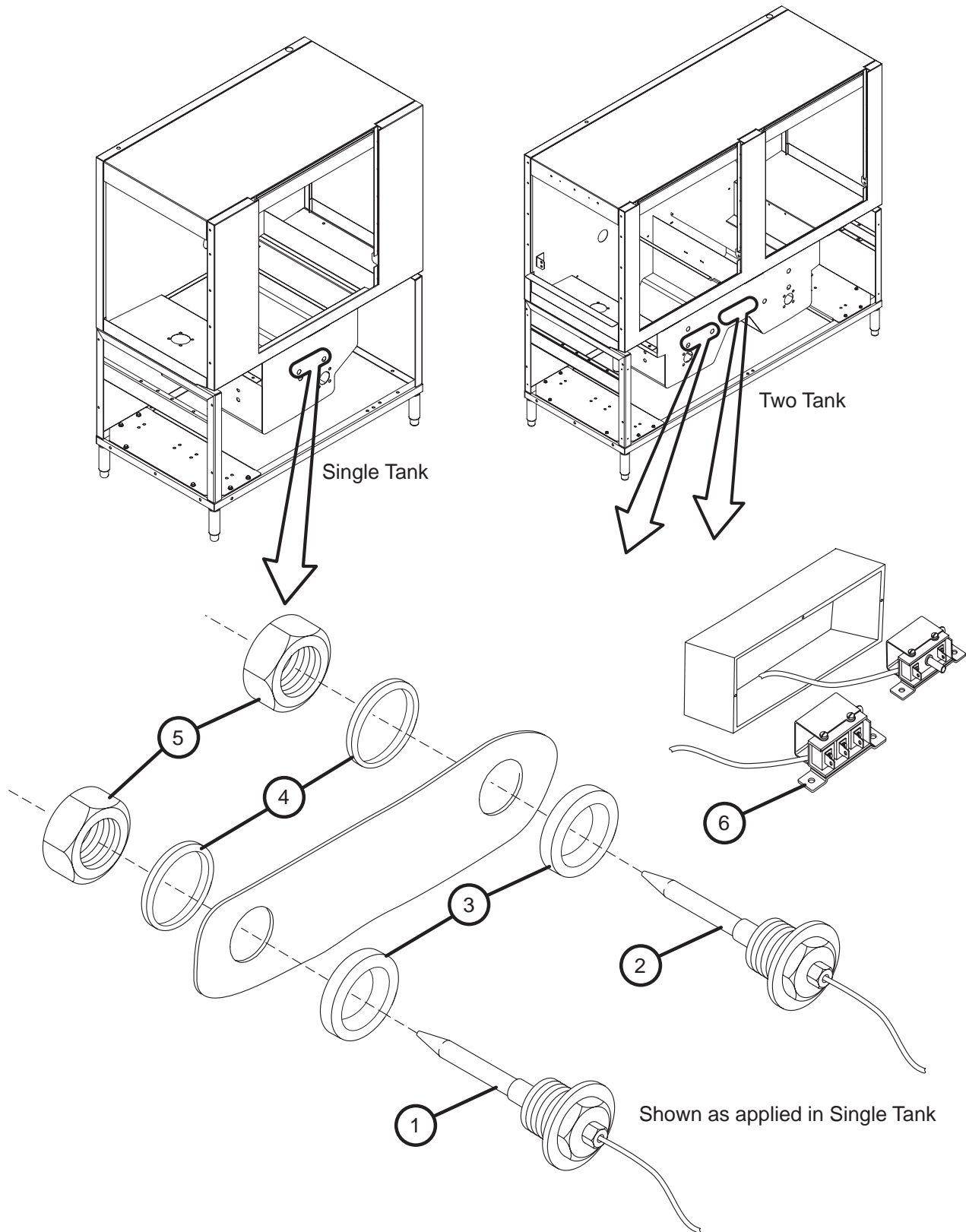

Figure 34- Tank Thermostats

TANK THERMOSTATS

Fig. 34 Item No.	Part No.	Part Description	Qty
1	109069	Thermostat w/capillary (Single)	1
	109069	Thermostat w/capillary (Two)	2
2	113200	Thermostat, Fixed Hi Limit (Single)	1
	113200	Thermostat, Fixed Hi Limit (Two)	2
3	201041	Washer 7/8 ID x 1/8 Thk (Single)	2
	201041	Washer 7/8 ID x 1/8 Thk (Two)	4
4	109034	Gasket. Plug (Single).....	2
	109034	Gasket. Plug (Two)	4
5	100547	Locknut 1-1/2 NPT SST (Single)	2
	100547	Locknut 1-1/2 NPT SST (Two)	2
6		Thermostat Bracket (Per Thermostat)	1
7	323430	Bracket, Thermostat (Not Shown)(Per Box)	1

***Hi-limit is always located over the element inside of the tank.**

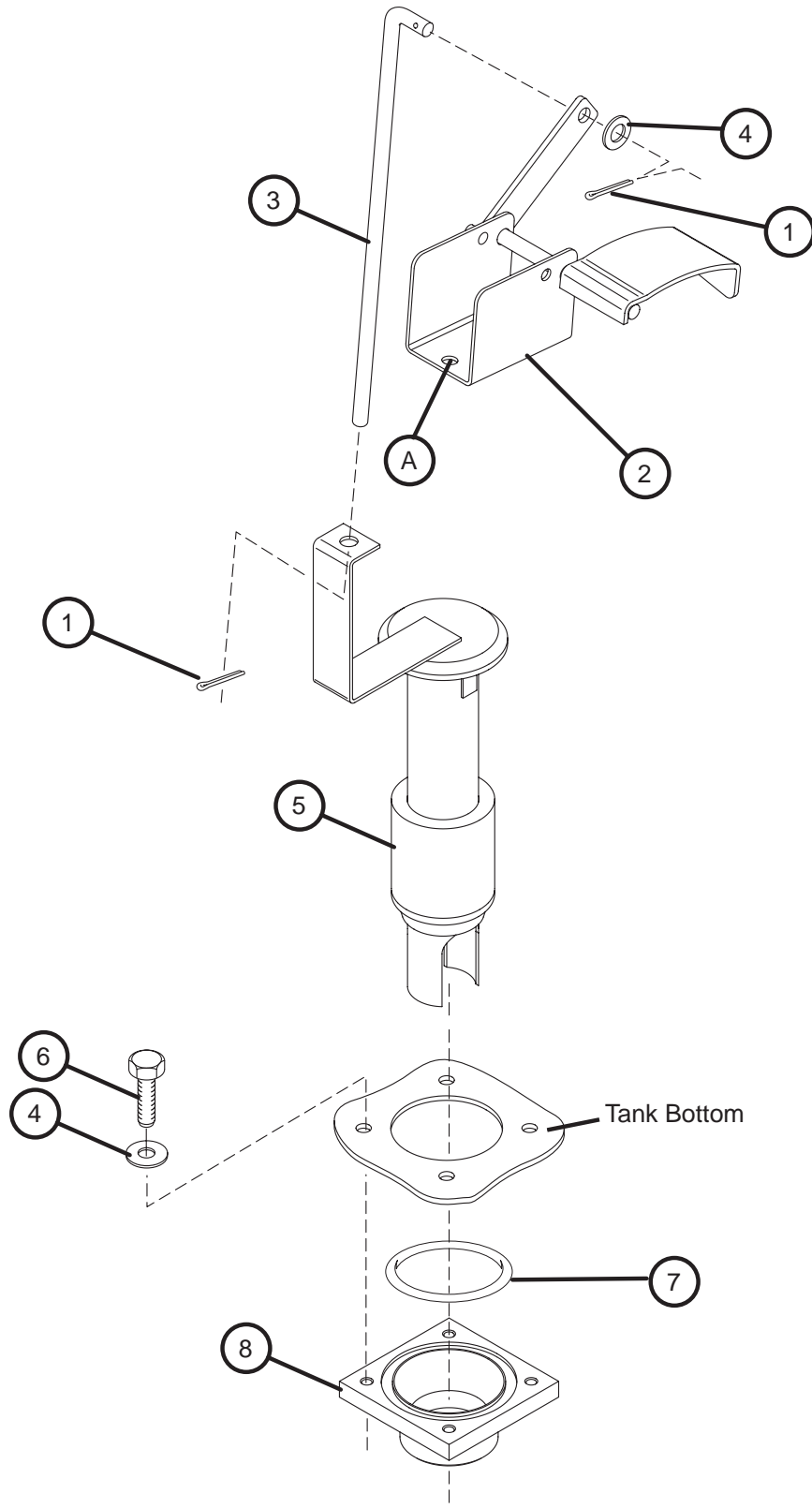

Figure 35- Prewash Overflow Assembly

PREWASH OVERFLOW ASSEMBLY

Fig. 35	Part		
Item No.	No.	Part Description	Qty
1	108875	Cotter Pin 3/32 x 1/2 Uneven	2
2	328824	Lever Drain Lift	1
3	206417	Rod, Overflow Lift 22PW	1
4	106026	Washer 1/4 x 5/8 x 1/6 SST	5
5	328430	Overflow PW Mtd.....	1
6	100735	Bolt 1/4-20 x 5/8 Hex Head	4
7	111532	O-ring, Drain 1.600 ID x .21	1
8	113559	Drain , Flange Cast/Mach SST	1

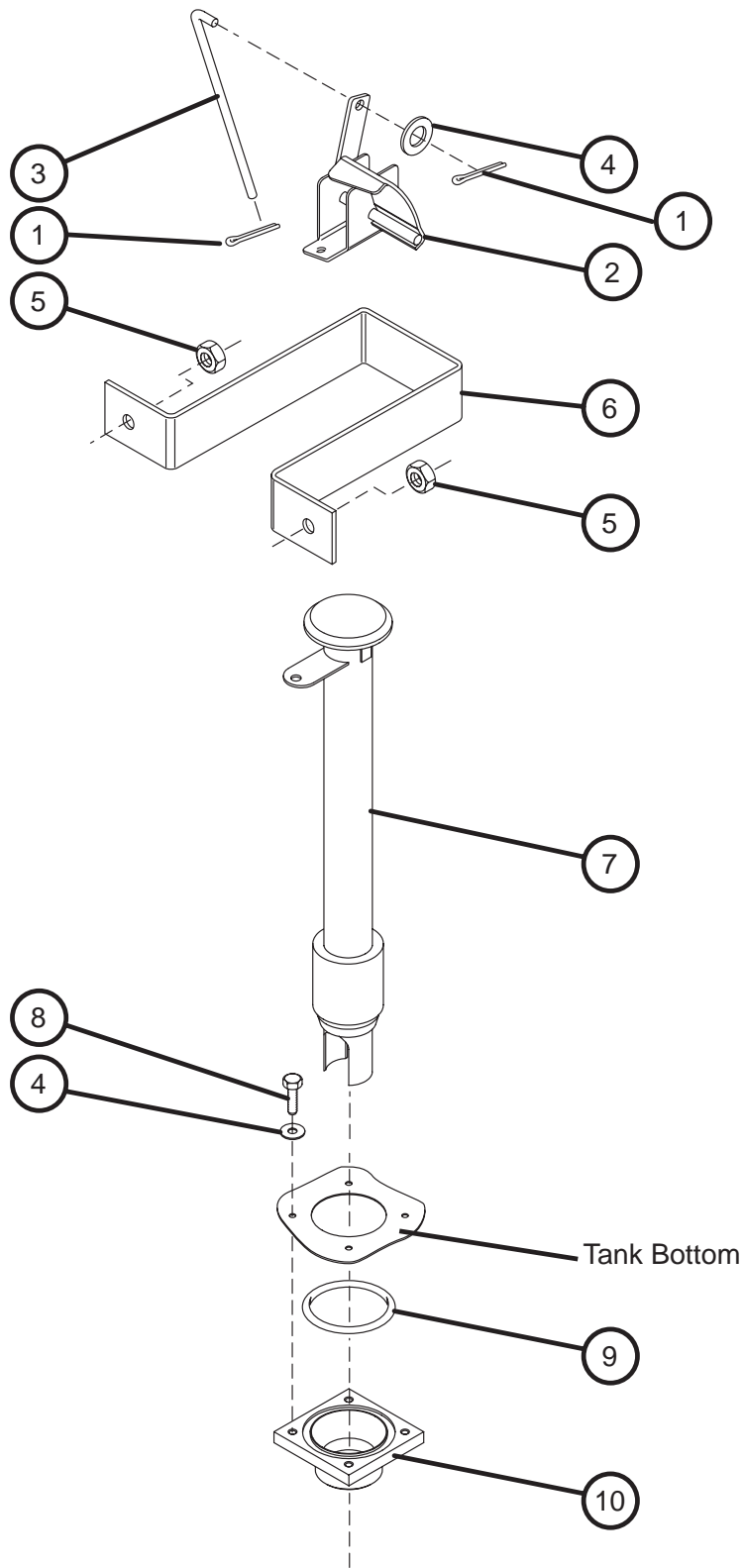

Figure 36- Single Tank and Two Tank
Overflow Assembly

**SINGLE TANK AND TWO TANK
OVERFLOW ASSEMBLY**

Fig. 36	Part		
Item No.	No.	Part Description	Qty
1	108875	Cotter Pin 3/32 x 1/2 Uneven	2
2	328611	Lever Drain Lift	1
3	327850	Rod, Overflow Lift	1
4	106026	Washer 1/4 x 5/8 x 1/6 SST	5
5	107966	Nut, Grip 10-32 w/Nylon Insert	2
6	327975	Bracket, Drain/Overflow	1
7	414342	Overflow (44Wash)	1
7	414343	Overflow (64 Rinse)	1
8	100735	Bolt 1/4-20 x 5/8 Hex Head	4
9	111532	O-ring, Drain 1.600 ID x .21	1
10	113559	Drain , Flange Cast/Mach SST	1

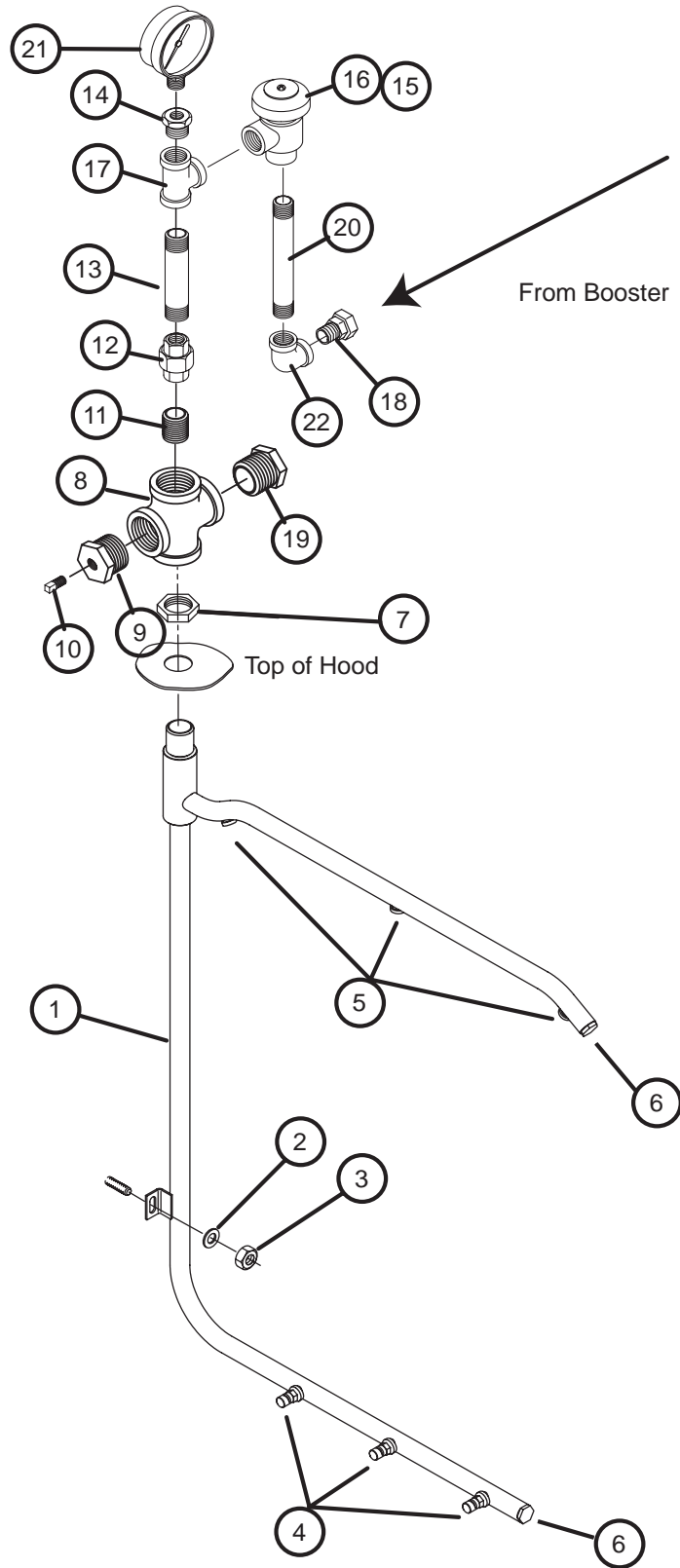

Figure 37- Final Rinse Piping w/Booster

**FINAL RINSE
PIPING W/BOOSTER**

Fig. 37 Item No.	Part No.	Part Description	Qty
1	113694	Manifold 44/64 L-R Final Rinse	1
2	106026	Washer 1/4 x 5/8 x 1/16 SST	1
3	107967	Nut Grip 1/4-20 w/Nylon Insert	1
4	112022	Nozzle, Spray K-2 2T Rack	3
4	107290	Nozzle 1/8 HU-SS 8015 (44WS)	3
5	107290	Nozzle, Spray 8015 SST(Replaces 113709)	3
5	0508376	Nozzle Rinse SST Upper (WS only)	3
6	113795	Plug 11/16-16 Thread	2
--	108620	Gasket Rinse Pipe (Not Shown)	1
7	100156	Locknut 3/4NPT Brass	1
8	100599	Cross 3/4" NPT Brass	1
9	105976	Bushing Red 3/4" NPT x 1/8" NPT Brass	1
10	101259	Plug 1/8" NPT Brass	1
11	100184	Nipple 3/4"NPT Close Brass	1
12	100571	Union 3/4"NPT Brass	1
13	102470	Nipple 3/4" NPT x 3" Lg Brass	1
14	102388	Bushing, Reducing 1/2"NPT x 1/4"NPT Brass	1
15	104429	Vacuum Breaker 3/4"NPT	1
16	900837	Kit*Repair, 3/4 Vacuum Breaker	A/R
17	102525	Tee, Red 3/4" x 1/2" x 3/4" NPT Brass	1
18	109879	Fitting Compression 3/4"NPT x 7/8" OD	1
19	100171	Bushing Red Face 3/4" NPT x 1/2 NPT Brass	1
20	102490	Nipple 1/4"NPT x 3-1/2" Lg Brass	1
21	100135	Pressure Gauge 0-60 PSI	1
22	102442	Elbow 3/4 x90° Brass	1

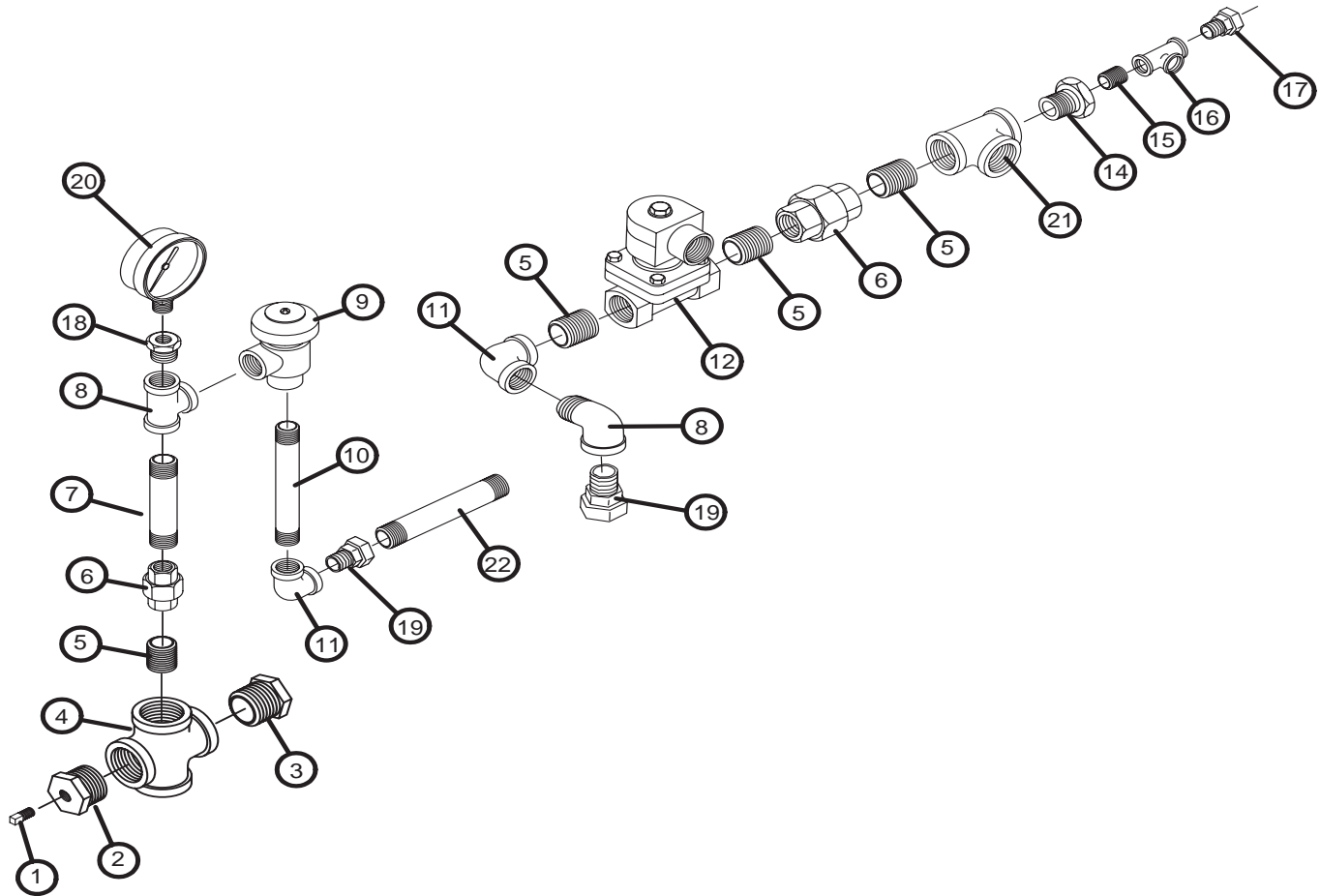

Figure 38- Piping No Booster/Steam Booster

PIPING NO BOOSTER/STEAM BOOSTER

Fig. 38	Part		
Item No.	No.	Part Description	Qty
1	101259	Plug, 1/8" NPT Brass	1
2	105976	Bushing, Red 3/4" NPT x 18" NPT Brass	1
3	100171	Bush Red Face 3/4" NPT x 1/2" NPT Brass	1
4	100599	Cross, 3/4"NPT Brass	1
5	100184	Nipple 3/4" NPT Close Brass	4
6	100571	Union 3/4" NPT Brass	2
7	102470	Nipple 3/4" x 3" Lg Brass	2
8	102525	Tee Red 3/4 x 1/2 x 3/4 Brass	1
9	104429	Vacuum Breaker 3/4" NPT Brass	1
--	900837	Kit*Repair, Vacuum Breaker 3/4"	A/R
10	102490	Nipple 3/4" NPT x 3-1/2"Lg Brass	1
11	102442	Elbow 3/4"NPT x 90° Brass	1
12	111437	Valve, Solenoid 3/4" HW	1
--	109903	Kit Repair 3/4 JE Stm-Wat	A/R
--	111472	Replacement Coil 3/4" Solenoid Valve	A/R
13	107418	Tee, 3/4"NPT x 3/4"NPT x 1/4"NPT Brass	1
14	102392	Bushing Red 3/4" x 1/2" NPT	1
15	100209	Nipple 1/2" NPT Brass	1
16	102514	Tee 1/2" NPT Brass	1
17	111250	Fitting Compression 1/2 OD x 1/2 MPT	1
18	102388	Bushing, Reducing 1/2" NPT x 1/4" NPT Brass	1
19	109879	Fitting, Comp 7/8OD x 3/4 MPT Brass	1
20	100135	Pressure Gauge 0-60 PSI	1
21	102521	Tee 3/4" NPT Brass	1
22	102490	Nipple 3/4" NPT x 3-1/2"Lg Brass (w/Steam Booster Only) ..	1

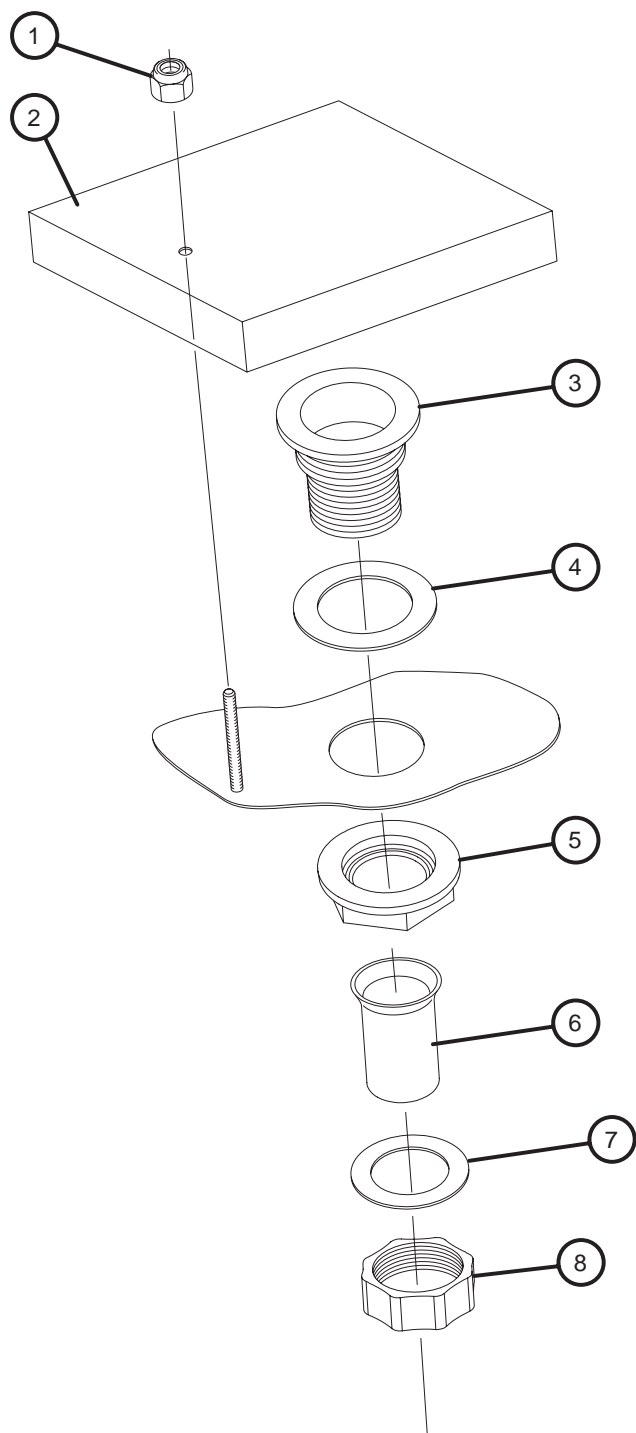

Figure 39- Final Rinse Drain Assembly

FINAL RINSE DRAIN ASSEMBLY

Fig. 39	Part		
Item No.	No.	Part Description	Qty
1	100141	Nut, Grip 1/4-20	1
2	305218	Strainer, F/R Drain	1
3	107342	Basket, Drain	1
4	107864	Washer, Packing-Neoprene	1
5	107345	Nut Slip	1
6	107473	Tailpiece	1
7	110245	Washer Tailpiece	1
8	110244	Nut Slip, Tailpiece	1

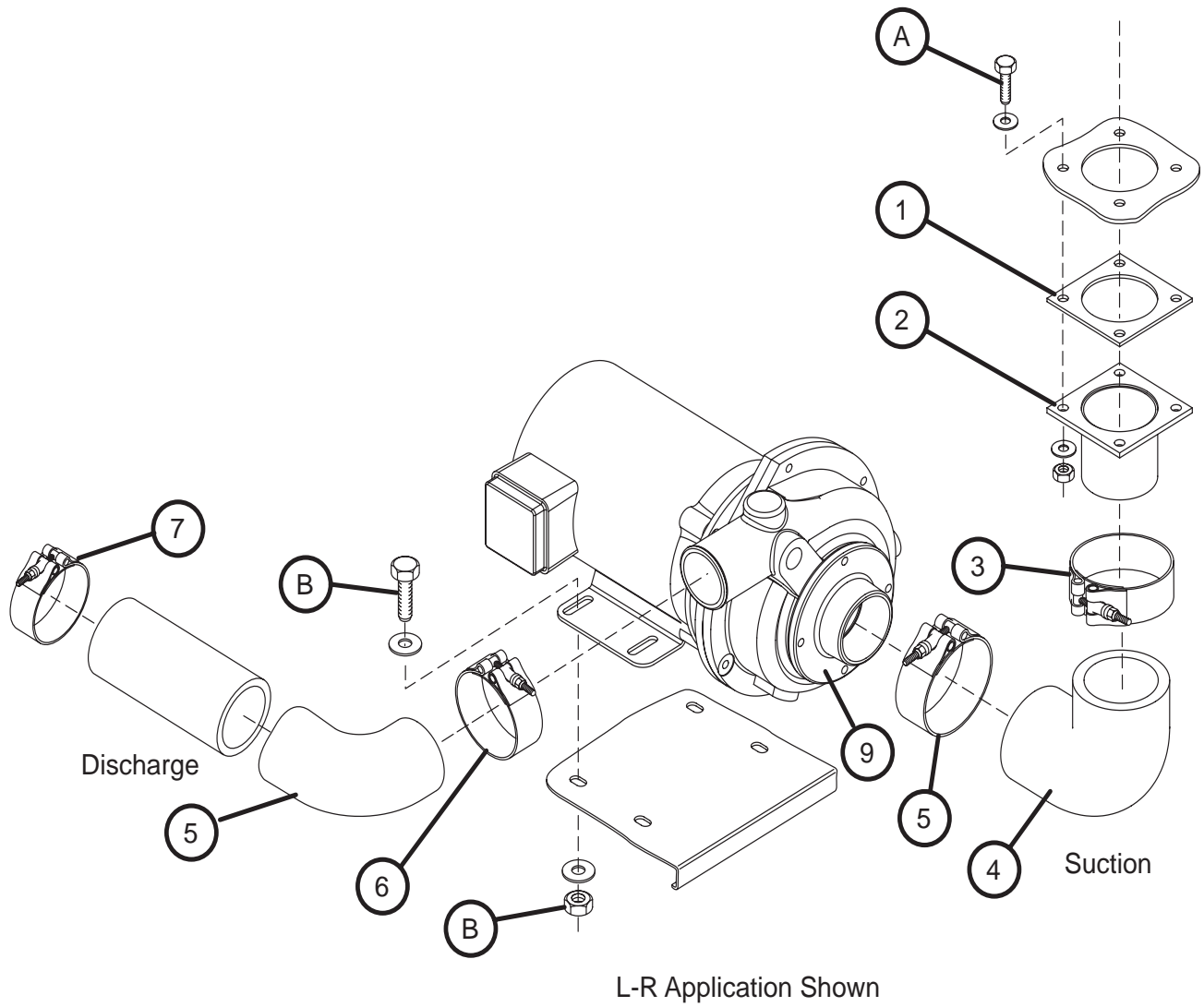

Figure 40- Prewash Pump Suction/Discharge

PREWASH PUMP SUCTION/DISCHARGE

Fig. 40	Part		
Item No.	No.	Part Description	Qty
1	109568	Gasket Pump Suction	1
2	307995	Flange, Suction	1
3	104203	Clamp, Hose M52 SST	2
4	113717	Hose, PW Suction	1
5	113731	Hose 22" PW Pump Discharge	1
6	104165	Clamp, Hose M40 SST	1
7	111964	Hose, Clamp Discharge	1
8	311761	Strainer, Pump Suction (Not Shown)	1
9	112379	Suction, Flange Machined	1
10	112338	Gasket Pump Suction Flange (Not Shown)	1

A Suction Flange Fasteners

B Pump Fasteners

100739	Bolt 5/16-18 x 3/4 Hex Head SST	4
102376	Washer 5/16 x 3/4 x 1/16	8
109009	Nut, Grip 5/16 w/Nylon Insert	4

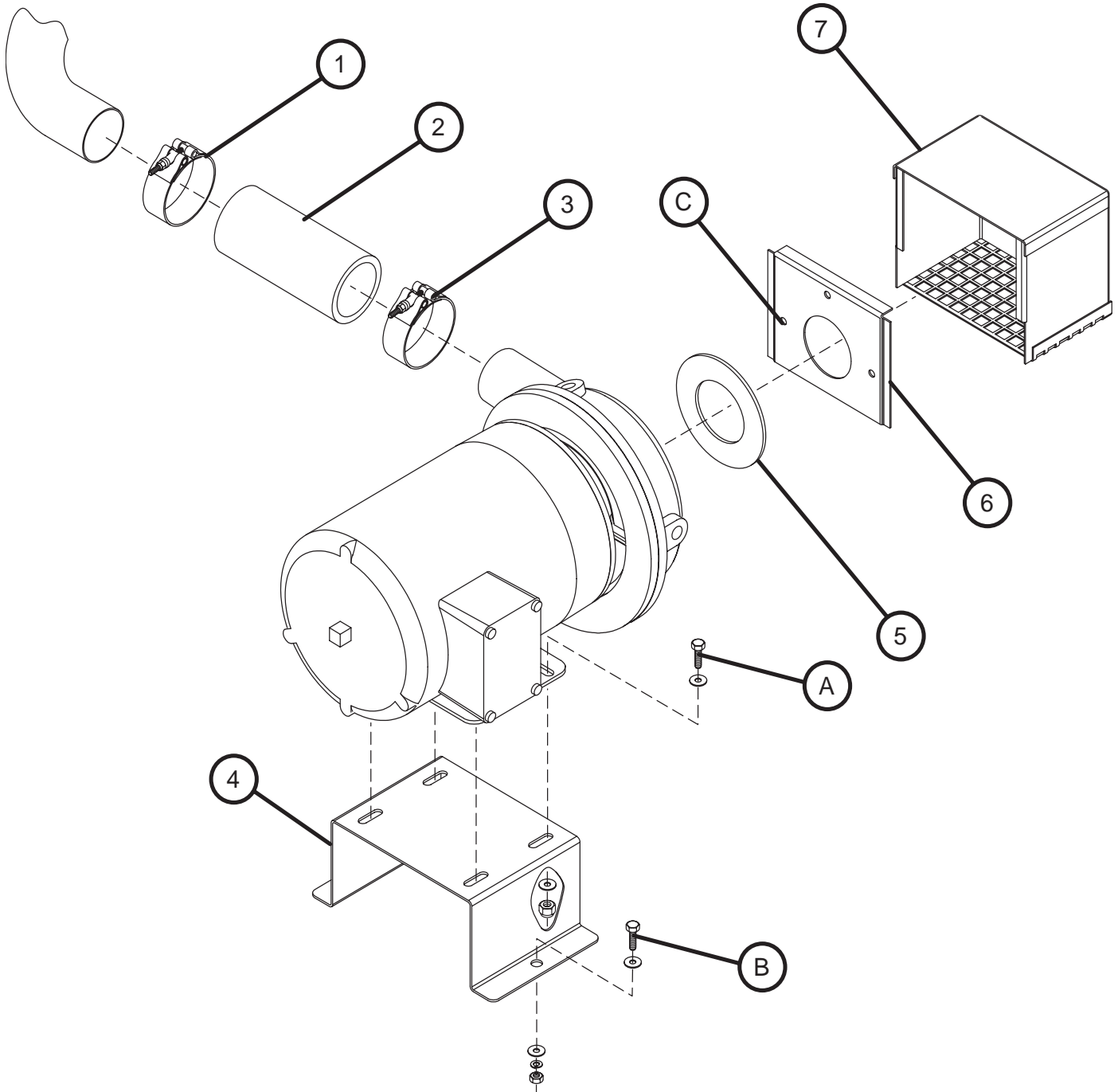

Figure 41- Wash/Rinse Pump Suction/Discharge

WASH/RINSE PUMP SUCTION/DISCHARGE

Fig. 41	Part		
Item No.	No.	Part Description	Qty
1	110858	Hose Clamp Pump Discharge	1
2	112801	Hose Discharge Pump	1
3	111780	Hose Clamp PP28 Discharge	1
4	327870	Pump Motor Base	1
5	113538	Gasket Pump Suction	1
6	327906	Plate, Pump Suction	1
7	327905	Hood Pump Suction	1
A	Pump Base Fasteners		
	100739	Bolt 5/16-18 x 3/4 Hex Head SST	4
	102376	Washer 5/16 x 3/4 x 1/16	8
	109009	Nut Grip 5/16 w/Nylon Insert	4
B	Pump Fasteners		
	100739	Bolt 5/16-18 x 3/4 Hex Head SST	4
	102376	Washer 5/16 x 3/4 x 1/16	8
	109009	Nut, Grip 5/16 w/Nylon Insert	4

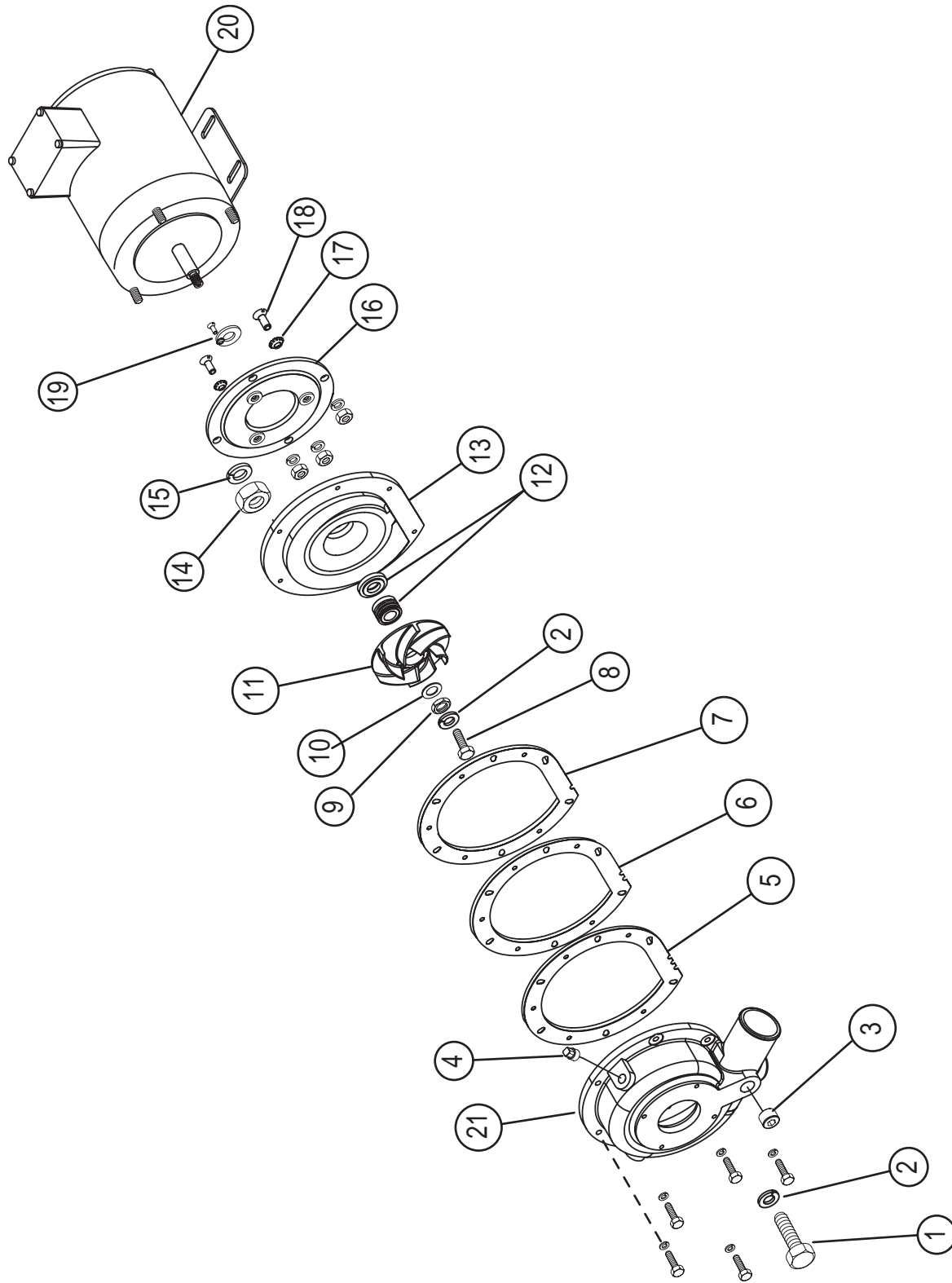

Figure 42- Pump Assembly

PUMP ASSEMBLY

Fig. 42	Part		
Item No.	No.	Part Description	Qty
1	100736	Screw 1/4-20 x 3/4 Hex Head	6
2	106482	Washer, Lock 1/4"	10
3	113705	Plug 1/2" NPT Countersunk Brass (2HP) (Wash/Rinse)	1
3	102504	Plug 1/2" NPT Brass Sq Head (1HP) (Prewash)	1
4	102500	Plug 1/4" NPT Brass	2
5	111943	Gasket .032 Thk (3 Notches)	1
6	111942	Gasket .015 Thk (2 Notches)	1
7	111941	Gasket .0085 Thk (1 Notch)	1
8	100735	Screw 1/4-20 x 5/8 Hex Head	1
9	110247	Nut Jam Hex 7/16-20 SST	1
10	110248	Washer .44OID x .043SST	1
11	113118	Impeller 1HP, SST Machined (Prewash)	1
	113603	Impeller 2HP, SST Machined (Wash/Rinse)	1
12	111111	Seal Pac Type 16	1
13	113635	Flange, Jet Pump, SST NG	1
14	107690	Nut, Jam 3/8-16	4
15	106407	Washer, Lock 3/8 Split	4
16	204460	Backing Plate 1Hp, 2HP, 3HP	1
17	110270	Washer, C-Sunk, Ex-Tooth SST	3
18	100754	Screw 10-32 x 1/2 Flat Head	3
19	109654	Slinger-Comenda	1
20	110420	Motor 1HP 208-240/460 60Hz/3Ph	A/R
	113420	Motor 2HP 208-240/460/60Hz/3Ph (Wash/Rinse)	1
21	112380	Pump Volute Machine (Prewash)	1
	113634	Pump Volute SST (Wash/Rinse)	1
---	112338	Gasket, Pump Suction Flange (Not Shown)	1
	451523	Pump Assy 1HP 3Ph R-L Complete (Prewash)	A/R
	414506	Pump Assy 2HP LH Complete (Wash/Rinse)	A/R
	414505	Pump Assy 2HP RH Complete (Wash/Rinse)	A/R
	900737	Kit*Gaskets, Jet Pump (Includes Items 5-7)	A/R
	900183	Kit*Seal & 1HP Impeller (Includes Items 5-7, 11 and 12)	A/R
	900861	Kit*Seal & 2Hp Impeller (Includes Items 5-7, 11 and 12)	A/R

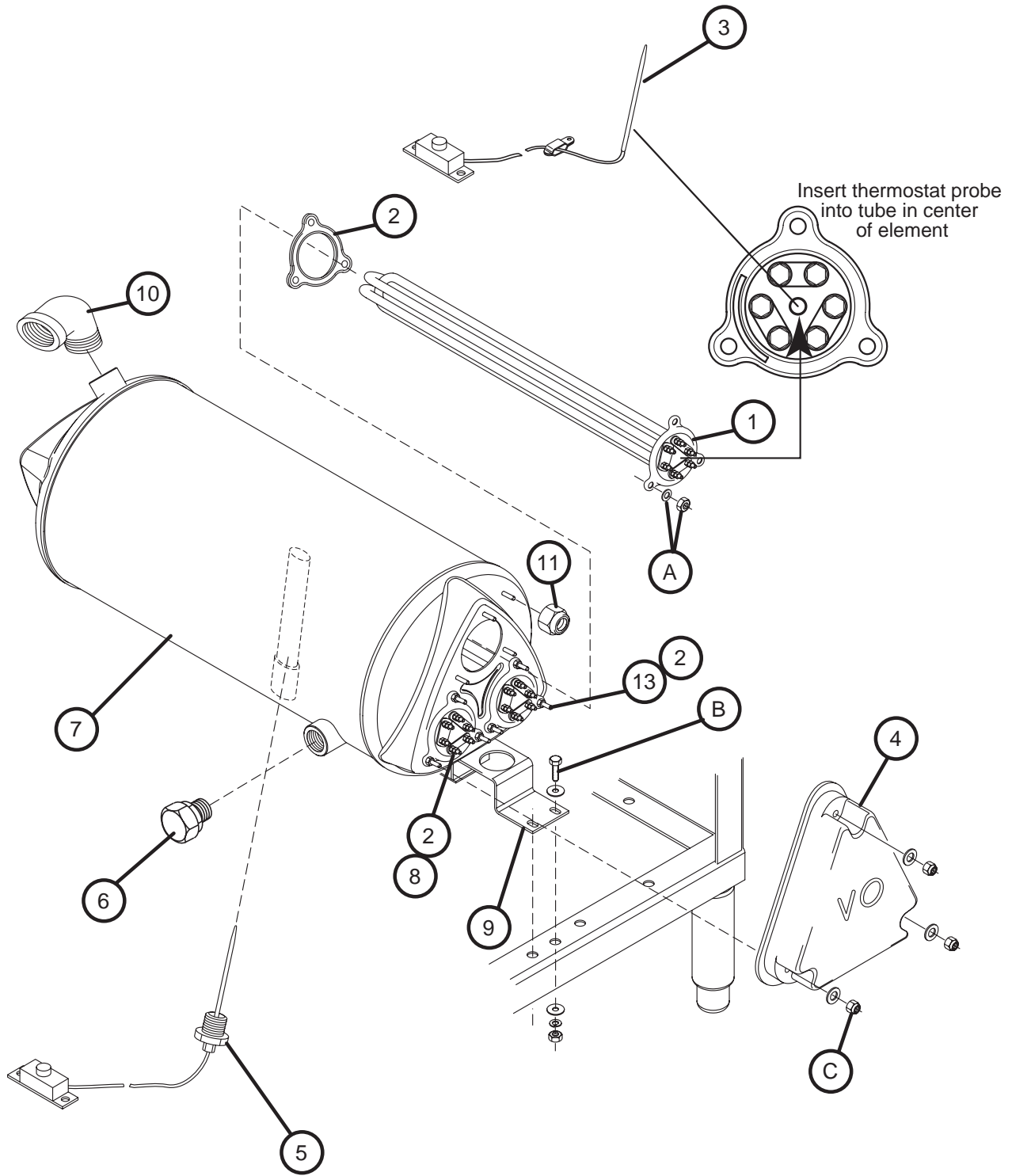

Figure 43- 40°/60° Rise Electric Booster

40°/60 RISE ELECTRIC BOOSTER

Fig. 43 Item No.	Part No.	Part Description	Qty
1	113690	Heater, 12KW 208/60/3Ph (60°)(200-220V/1Ph & 3PH)	1
	113885	Heater, 12KW 220/230/240/380/415V 3Ph (60°)(230-240/1PH & 3PH) ...	1
	113886	Heater, 12KW 460/480V 3Ph (60°)	1
	113887	Heater, 12KW 575V 3Ph(60°)	1
	111233	Heater 7.5/10KW 240V 3Ph (40° Rise)(200-220,230-240V/1PH) .	1
	111232	Heater, 10KW 208V 3PH (40° Rise)(220-220/3PH)	1
	111234	Heater, 10KW 480V 3PH (40° Rise) (480V 3PH).....	1
	111383	Heater, 10KW 575V 3PH (40° Rise) (480V 3PH).....	1
2	109985	Seal, Electric Heater Flange	3
3	113724	Thermostat w/Capillary 210°F	1
4	108576	Cover, Booster No Cutout	1
5	109069	Thermostat w/ Capillary	1
6	102505	Plug 3/4" NPT Brass	1
7	414331	Tank Booster (40° Rise).....	1
8	113690	Heater, 12KW 208/60/3Ph (40°)(200-220V/1Ph & 3PH)	1
	113885	Heater, 12KW 220/230/240/380/415V 3Ph (40°)(230-240/1PH & 3PH) ...	1
	113886	Heater, 12KW 460/480V 3Ph (40°)(460-480°/3PH)	1
	112059	Heater, 12KW 208V 3Ph (60°Rise)(200-220V/1PH & 3PH) .	2
	111334	Heater 12KW 240V 3Ph (60° Rise) (230-240/1PH & 3PH) ...	2
	112060	Heater 12KW 460/480V 3Ph(60°Rise)(460-480/3PH)	2
	112061	Heater 12KW 575V 3Ph (60° Rise)	2
9	328254	Bracket, Front Booster	1
10	113706	Elbow Street 3/4 x 45 Brass (44)	1
11	108954	Nut Grip 6-32 w/Nylon Insert	1
12	328048	Clamp, Thermostat Booster Tank (Not shown, use with item 11)..	1
13	111235	Heater, 5/6.6KW 208/240 (40° Rise)(200-220V/1PH & 3PH).....	1
	111236	Heater 5KW 240V 3PH (40° Rise)(230-240V1PH & 3PH)....	1
	111237	Heater 5KW 480V 3PH (40° Rise) (460-480V/3PH)	1
	111384	Heater 5KW 575V 3PH (40° Rise) (460-480V/3PH)	1
A	Element Fasteners (Qty per Element)		
	100003	Nut Plain 1/4-20	9
	106482	Washer Lock 1/4 Split	9
B	Booster Tank Fasteners		
	100739	Bolt 5/16-18 x 3/4 Hex Head SST	4
	106013	Washer Lock 5/16 Split	4
	109205	Nut, Grip 5/16 w/Nylon Insert	4
C	Element Cover Fasteners		
	107697	Nut Grip 1/4-20 w/Nylon insert	3
	106026	Washer Flat 1/4"	3

Thermostat Placement

- Select correct element numbers from chart above for specific voltage
- Limiting thermostat **113724** Should be inserted into center of element **113690** (use voltage specific element). Thermostat should bottom out in the tube approximately 12" deep. The exposed capillary leads should be routed under cover **108576** and fastened to the weld stud in the upper right side of the booster can with the clip **328048** and nut.
- Regulating thermostat **109069** should be inserted into the tube on the bottom of the booster can until it hits the opposite wall approximately 9" then pulled back 1" and fastened in place.

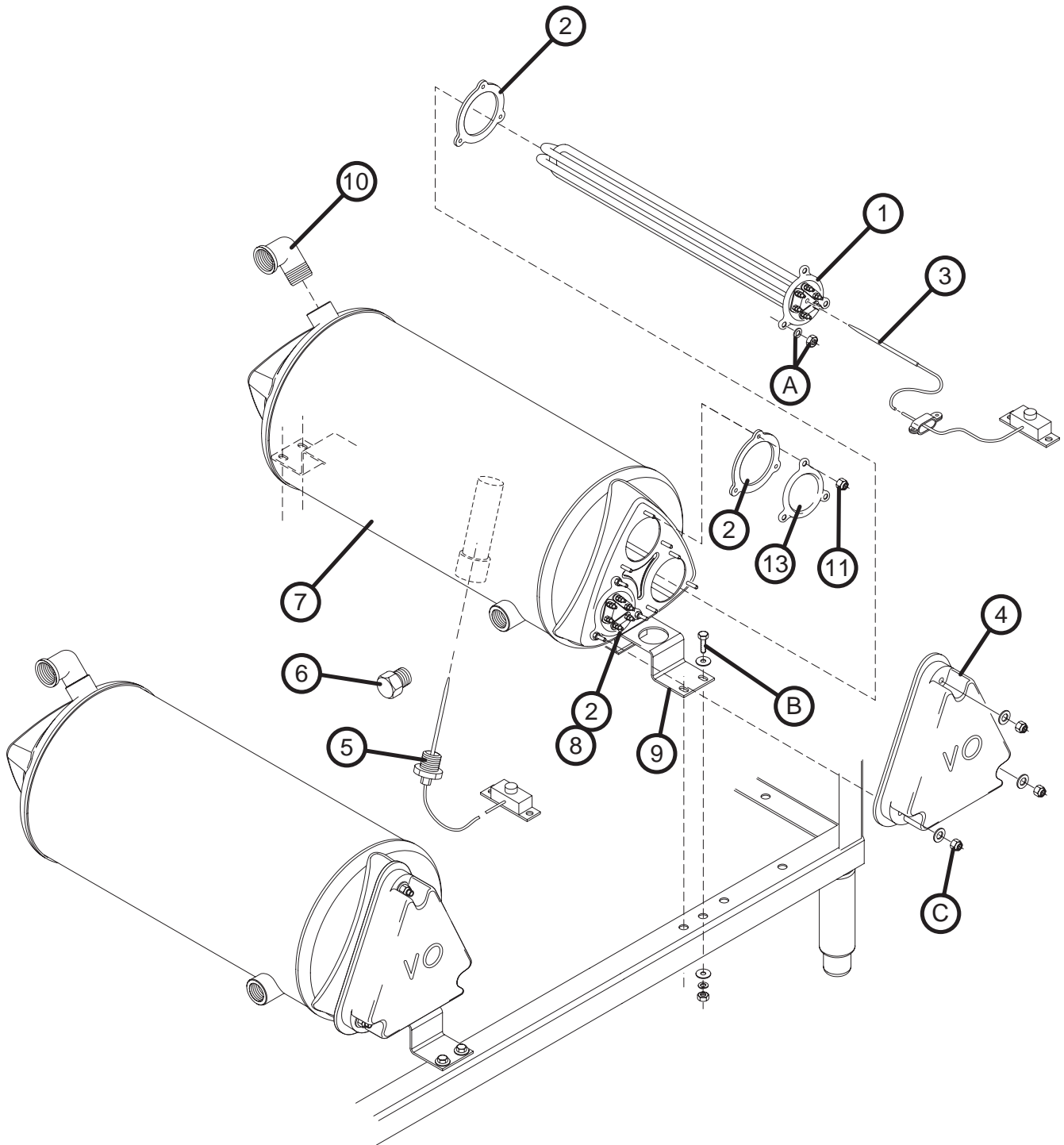

Figure 44- 70° Rise Electric Booster

70° RISE ELECTRIC BOOSTER

Fig. 44 Item No.	Part No.	Part Description	Qty
1	113690	Heater, 12KW 208/60/3Ph (200-220V/1Ph & 3PH)	1
	113885	Heater, 12KW 220/230/240/380/415V 3Ph (230-240/1PH & 3PH)	1
	113886	Heater, 12KW 460/480V 3Ph (60°)	1
	113887	Heater, 12KW 575V 3Ph(60°)	1
2	109985	Seal, Electric Heater Flange	6
3	113724	Thermostat w/Capillary 210°F	1
4	108576	Cover, Booster No Cutout	2
5	109069	Thermostat w/ Capillary	2
6	102505	Plug 3/4" NPT Brass (Not Shown) (On Opposite Side)	2
7	414331	Tank Booster (40° Rise)	2
8	112059	Heater, 12KW 208V 3Ph (200-220V/1PH & 3PH)	2
	111334	Heater 12KW 240V 3Ph (230-240/1PH & 3PH)	2
	112060	Heater 12KW 460/480V 3Ph(460-480/3PH)	2
	112061	Heater 12KW 575V 3Ph	2
9	328254	Bracket, Front Booster	2
10	113706	Elbow Street 3/4 x 45 Brass (44)	2
11	108954	Nut Grip 6-32 w/Nylon Insert	2
12	328048	Clamp, Thermostat Booster Tank (Not shown, use with item 11)..	2
13	109458	Flange Heater Bloc/off	2
A	Element Fasteners (Qty per Element)		
	100003	Nut Plain 1/4-20	9
	106482	Washer Lock 1/4 Split	9
B	Booster Tank Fasteners (Qty per Booster)		
	100739	Bolt 5/16-18 x 3/4 Hex Head SST	4
	106013	Washer Lock 5/16 Split	4
	109205	Nut, Grip 5/16 w/Nylon Insert	4
C	Element Cover Fasteners (Qty per Cover)		
	107697	Nut Grip 1/4-20 w/Nylon insert	3
	106026	Washer Flat 1/4"	3

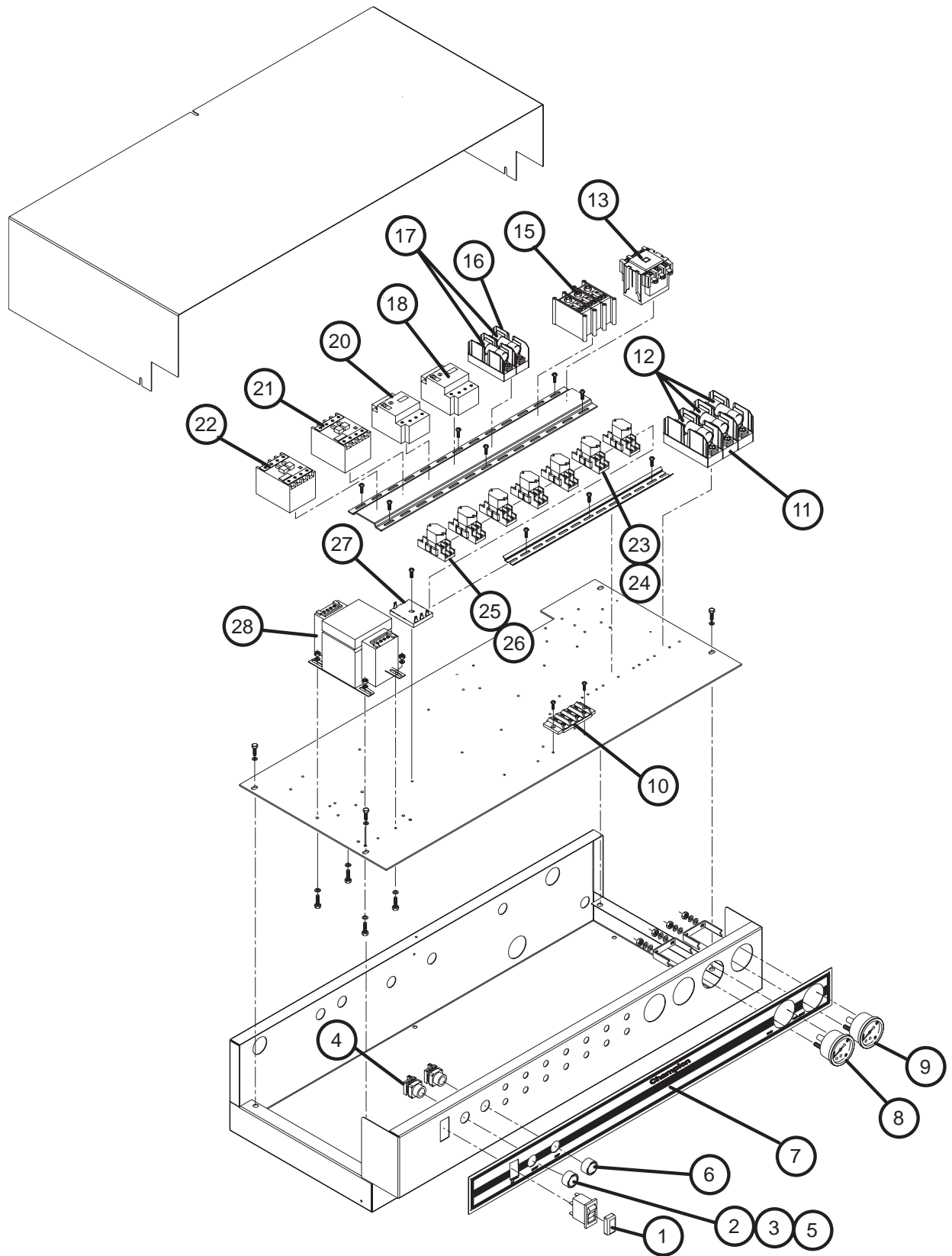

Figure 45- Control Cabinet

CONTROL CABINET

Fig. 42 Item No.	Part No.	Part Description	Qty
1	111980	Circuit Breaker On/Off 5amp	1
2	113814	Switch Pushbutton Green Illuminated	1
3	113752	Mounting Base Led Green	1
4	113812	Contact Block NO W/O Base	1
5	113140	Boot, Silicone Pushbutton	2
6	900726	Red Pushbutton (Includes (1) of Item 5)	1
		Includes the following:	
	111615	Red Push Button	1
	111616	Contact Block NC w/holder	1
7	113684	Decal 44/54 Cabinet (Single Tank)	1
7	113710	Decal 40/60/64 Cabinet (Two Tank)	1
8	107440	Thermometer 8ft Flanged (Wash) (Single Tank)	1
8	107440	Thermometer 8ft Flanged (Rinse) (Two Tank)	1
9	113622	Thermometer 4Ft Gas Filled (Final Rinse)	1
10	100294	Terminal Block 6PT	1
--	112296	Label Detergent/Rinse Signal (Not Shown)	1
11	108424	Fuse Block 600V/100A 3P (208-220V/1PH)(230-240V/1PH)	1
11	180171	Fuse Block 600V/60A 3P (208-220V/3PH)(230-240V/3PH).	1
11	180171	Fuse Block 600V/60A 3P (230-240V/3PH)(Two Tank)	2
11	111135	Fuse Block 600V/30A 3P (460-480V/3PH)(Single Tank)	1
11	111135	Fuse Block 600V/30A 3P (460-480V/3PH) (Two Tank)	2
12	108448	Fuse T 90A 250V Fast Act (208-220V/1PH)	2
12	180059	Fuse T 80A 250V Fast Act (230-240V/1Ph)	2
12	180175	Fuse J 50A 600V Fast Act (208-220V/3PH)	3
12	180175	Fuse J 50A 600V Fast Act (230-240V/1PH)(Two Tank Only)	2
12	180174	Fuse J 45A 600V Fast Act (230-240V/3PH)	3
12	180243	Fuse J 25A 600V Fast Act (460-480V/3PH)	3
12	111231	Fuse T 90A 250V Fast Act (208-220V/1PH)(Two Tank Only)	2
12	180176	Fuse J 60A 600V Fast Act (208-220V/1PH)(Two Tank Only)	2
12	180172	Fuse J 35A 600V Fast Act (208-220V/3PH)(Two Tank Only)	3
12	111683	Fuse J 30A 600V Fast Act (230-240V/3PH)(Two Tank Only)	3
12	112062	Fuse J 20A 600V Fast AcT (460-480V/3PH)(Two Tank Only)	3
13	111231	Contactor 75FLA 3p (Tank Heat) (208-220V/1PH)(230-240V/1PH)	1
13	111827	Contactor 60FLA 3P (Tank Heat) (208-220V/3PH), (230-240V/3PH), (460-480V/3PH)	1
13	111827	Contactor 60FLA 3P (Tank Heat)(208-220V/3PH)(Two Tank Only)	2
14	103310	Wire Lug QA-2 (Not Shown)	1
15	111833	Terminal Block 185A 3Pole 600V	1
16	106402	Fuse Block 600V/30A 2P (208-220V/1PH & 3PH)(230-240V/1PH)....	1
17	111821	Fuse ATDR-3 600V Time Delay (208-220V/1PH & 3PH), (230-240V/1PH & 3PH), (460-480V/3PH)	2
18	111630	Starter Mtr 13.0-18.0 (Wash) (208-220V/1PH),(230/240V/1PH) (Single Tank)	1
18	111630	Starter Mtr 13.0-18.0 (Wash/Rinse) (208-220V/1PH), (230/240V/1PH)(Two Tank)	2
18	110807	Starter Mtr OL GV2-M14 W/Aux (Wash) (208-220V/3PH), (230-240V/3PH) (Single Tank)	1
18	110807	Starter Mtr OL GV2-M14 W/Aux (Wash/Rinse) (208-220V/3PH), (230-240V/3PH) (Two Tank)	2
18	110805	Starter Mtr 2.5-4.0A w/Auxillary(Wash) (460-480V/3PH) (Single Tank)	1

CONTROL CABINET

Fig. 42 Item No.	Part No.	Part Description	Qty
19	113161	Starter Mtr OL 9.0-14.0 Amps (Prewash)(1HP) (208-220V/1PH) (230-240V/1PH)(Not Shown)	1
19	110806	Starter Mtr OL GV2-M10 w/Auxillary (Prewash) (1HP) (208-220V/3PH), (230-240/V3PH)(Not Shown)	1
19	110804	Starter Mtr OL GV2-M07 w/Auxillary (Prewash) (1HP) (460-480V/3PH) (Not Shown)	1
20	110803	Starter Mtr OL GV2-M06 w/Aux (Drive) (208-220V/1PH & 3PH) (230-240V/1PH & 3PH)	1
20	110801	Starter Mtr OL GV2-M04 w/Auxillary (Drive)(460-480V/3PH)	1
---	111639	Auxillary Switch (Attached to Overload) (Not Shown)	A/R
21	108122	Contactactor 12A (Motor)(Prewash,Wash, Rinse)(208-220V/3PH), (230-240V/3PH), (460-480V/3PH)	1
21	109582	Contactactor 25A (Motor) (Wash/Rinse) (208-220V/1PH)(230-240V/1PH)	1
22	108122	Contactactor 12A (Motor) (Drive)	1
23	111036	Relay Socket (Single/Two Tank)	6
23	113036	Relay Socket (w/Prewash)	7
24	111068	Relay 2PDT 10A 120VAC (Single/Two Tank)	6
24	111068	Relay 2PDT 10A 120VAC (w/Prewash)	7
---	113271	Suppressor, ARC (Single/Two Tank) (Not Shown)	5
---	113271	Suppressor, ARC (w/Prewash) (Not Shown)	6
25	112415	Relay Socket 3Pole	1
26	112382	Relay 3PDT 10A 120VAC	1
27	113782	Timer Fixed 90 Seconds	1
28	109064	Transformer 250VA 240/480, 230/460	1

This Page
Intentionally
Left
Blank

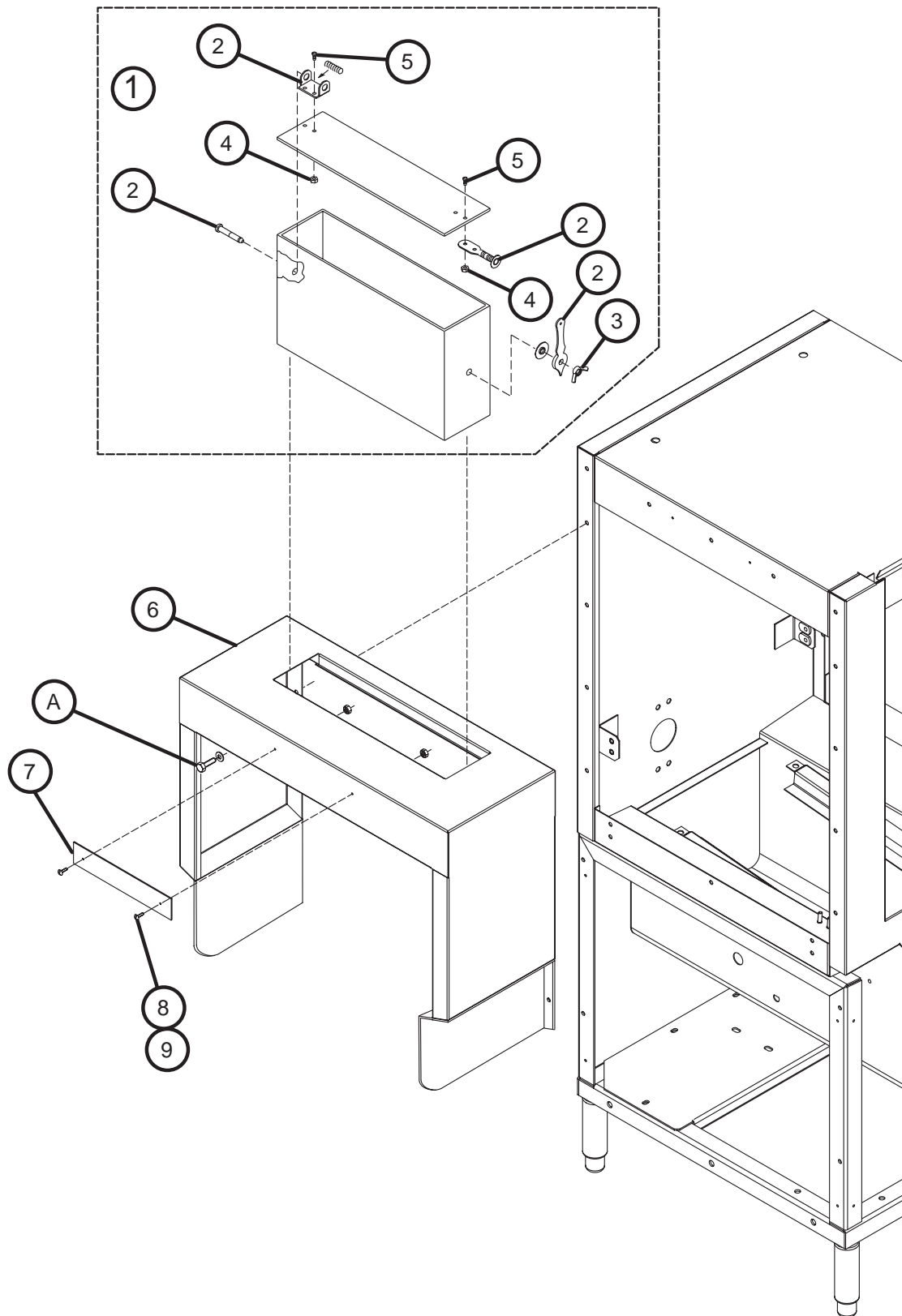

Figure 46- New Style Vent Cowls
(Shown Mounted to Prewash)

NEW STYLE VENT COWLS

Fig. 46	Part		
Item No.	No.	Part Description	Qty
1	401487	Vent Stack Assembly (Includes Items 2-5)	2
2	201589	Regulator Assembly	2
3	112258	Nut Wing 1/4-20 SST	2
4	108954	Nut, Grip 6-32 w/Nylon Insert	4
5	104883	Screw 6-32 x 3/8" Round Head	4
6	328344	Vent Cowl	2
7	109158	Nameplate "Champion"	2
8	107015	Screw 4-40 x 1/4 Round Head	4
9	107016	Nut Grip 4-40 w/Nylon Insert	4
A	Vent Cowl Fasteners (Qty per Cowl)		
	100734	Bolt 1/4-20 x 1/2 Hex Head SST	4
	106482	Nut Grip 1/4-20 SST	4

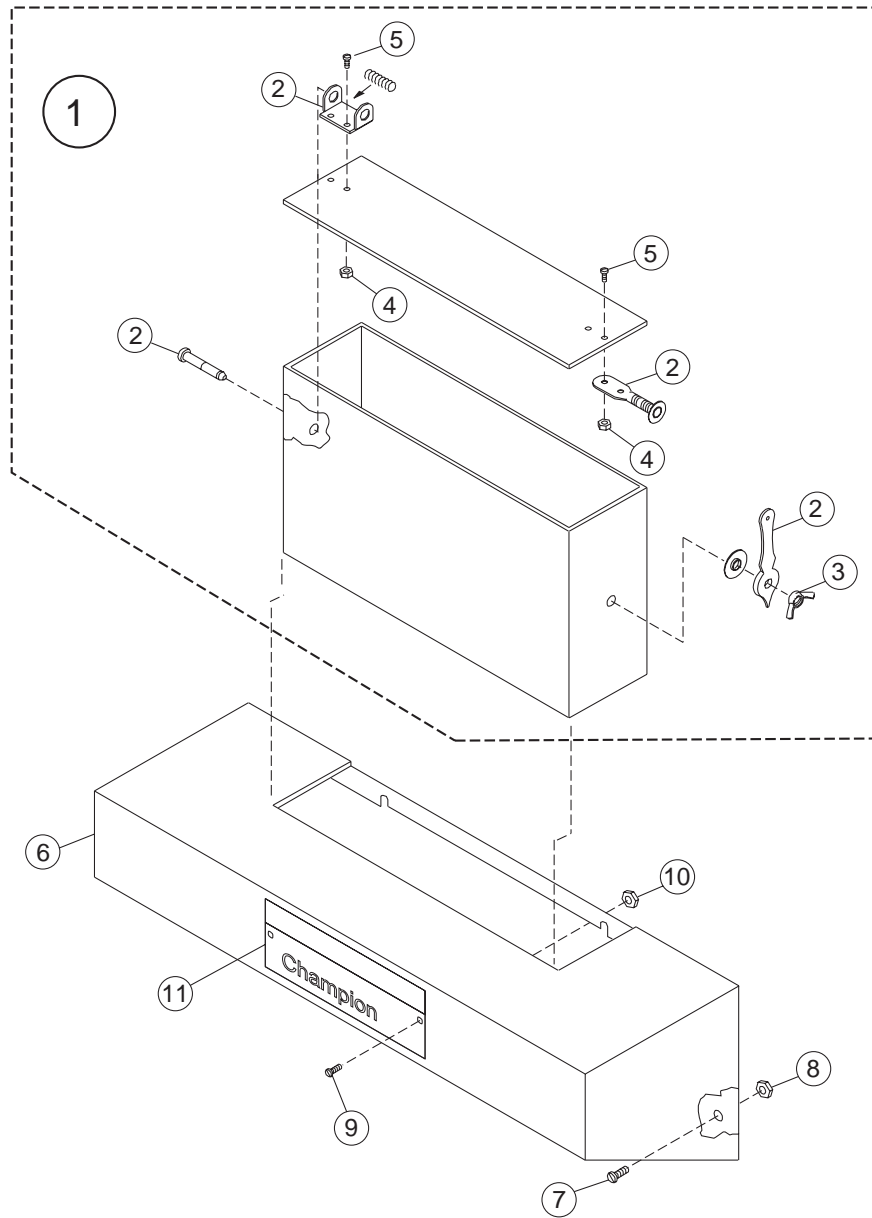

Figure 47- Standard Vent Cowls

STANDARD VENT COWLS

Fig. 47	Part		
Item No.	No.	Part Description	Qty
1	401487	Vent Stack Assembly (Includes items 2-5)	2
2	201589	Regulator Assembly	2
3	112258	Nut, Wing 1/4-20 SST	2
4	108954	Nut, Grip 6-32 w/Nylon Insert	8
5	104883	Screw 6-32 x 3/8 Round Head	8
6	307228	Vent Hood	2
7	100734	Belt 1/4-20 x 1/2" Hex Head	4
8	100141	Nut Grip 1/4-20	8
9	107015	Screw 4-40 x 1/4 Round Head	4
10	107016	Nut Grip 4-40 w/Nylon Insert	4
11	109518	Nameplate "Champion"	1
--	401889-S	Vent Hood Assembly (Includes Items 1-10)	

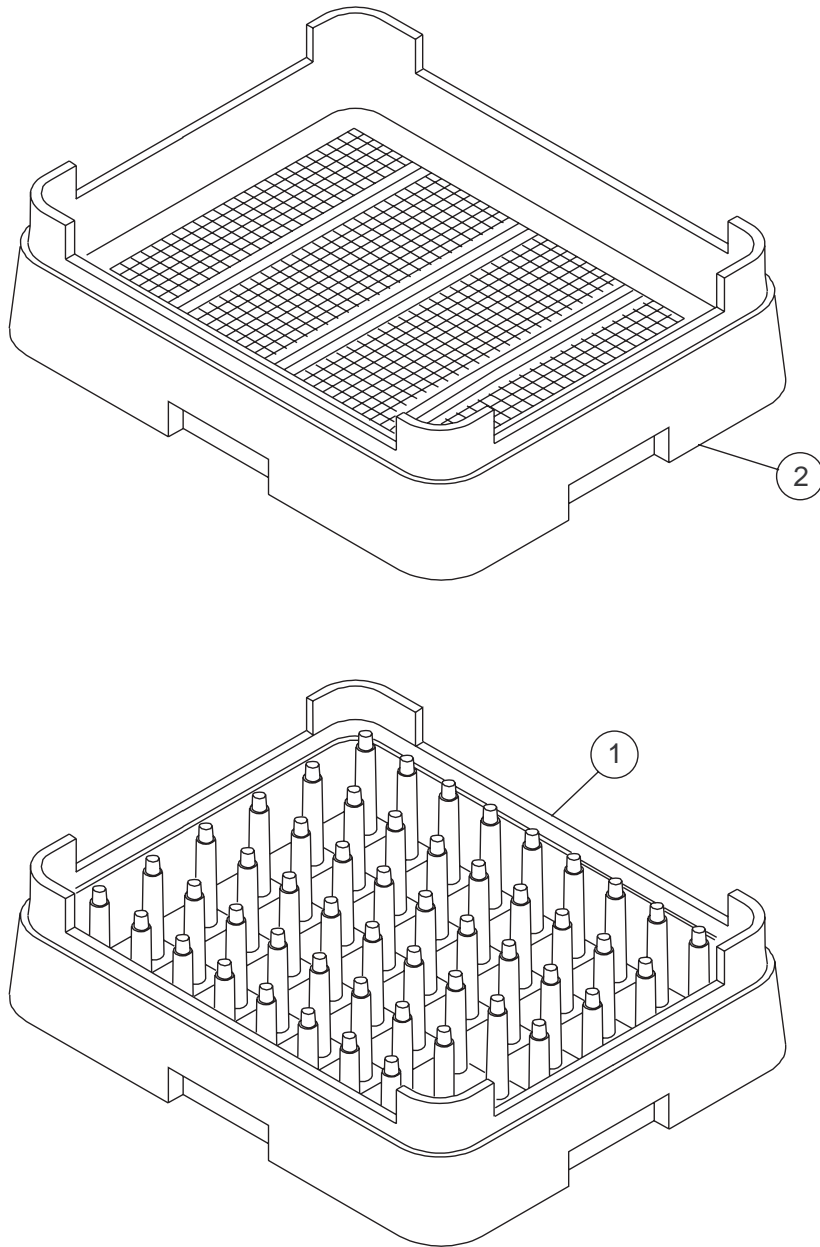

Figure 48- Dish Racks

DISH RACKS

Fig. 48	Part		
Item No.	No.	Part Description	Qty
1	101285	Rack Peg	1
2	101273	Rack Combination	1

This Page
Intentionally
Left
Blank

ELECTRICAL SCHEMATICS

MODELS COVERED BY THIS DRAWING	
44	
44 LT	
54	

NOTES:

- 7CR IS USED ONLY WITH A TABLE LIMIT SWITCH OR MRA TABLE. WHEN A TABLE LIMIT SWITCH IS NOT USED INSTALL JUMPER.
- WHEN TABLE LIMIT SWITCH OR MRA IS USED, CONNECT SWITCHES BETWEEN WIRES 6 AND 44 ON THE TERMINAL BLOCK IN THE PANEL.
- USED FOR MACHINE RUNNING SIGNAL.
- DRIVE MOTOR CONNECTED SINGLE PHASE FOR 200-240 VOLT MODELS.
- ON MODELS WITH SIDE LOADER OPTION DRIVE MOTOR CONTACTOR 1M IS CONNECTED TO WIRE #45 INSTEAD OF WIRE #11.
- ON MODELS WITH MULTIPLE ELECTRIC CONNECTIONS, MAKE HEATER POWER CONNECTIONS AT THE HEATER FUSE BLOCK.

1CR	RACK SWITCH RELAY
2CR	FINAL RINSE SWITCH RELAY
3CR	DOOR SAFETY SWITCH RELAY
5CR	WASH FILL RELAY
7CR	TABLE LIMIT SWITCH RELAY
1M	DRIVE MOTOR CONTACTOR
1MOL	DRIVE MOTOR OVERLOAD
3M	WASH MOTOR CONTACTOR
3MOL	WASH MOTOR OVERLOAD
5M	BLOWER MOTOR CONTACTOR
5MOL	BLOWER MOTOR OVERLOAD
AS	ARC SUPPRESSOR
BC-	BOOSTER CONTACTOR/STEAM VALVE
BDV	BLOWER DOOR SWITCH
BR	BOOSTER RELAY
BWR.SW.	BLOWER SWITCH
CR	HOLD-IN RELAY
FRSW	FINAL RINSE SWITCH
FU	FUSE/FUSE BLOCK
FV	FILL VALVE
HC-	HEAT CONTACTOR/STEAM VALVE
HLTS	HIGH LIMIT THERMOSTAT
JSW	JAM SWITCH
PCB	POWER SWITCH/CIRCUIT BREAKER
RSW	RACK SWITCH
RV	RINSE VALVE
T1	CONTROL TRANSFORMER
TLS	TABLE LIMIT SWITCH
TR1	IDLE PUMP TIMER
TS	THERMOSTAT
W	WASH DOOR SWITCH
WFSW	WASH TANK FLOAT SWITCH

DIAGRAM STATE
POWER OFF
DOORS CLOSED
TANKS EMPTY

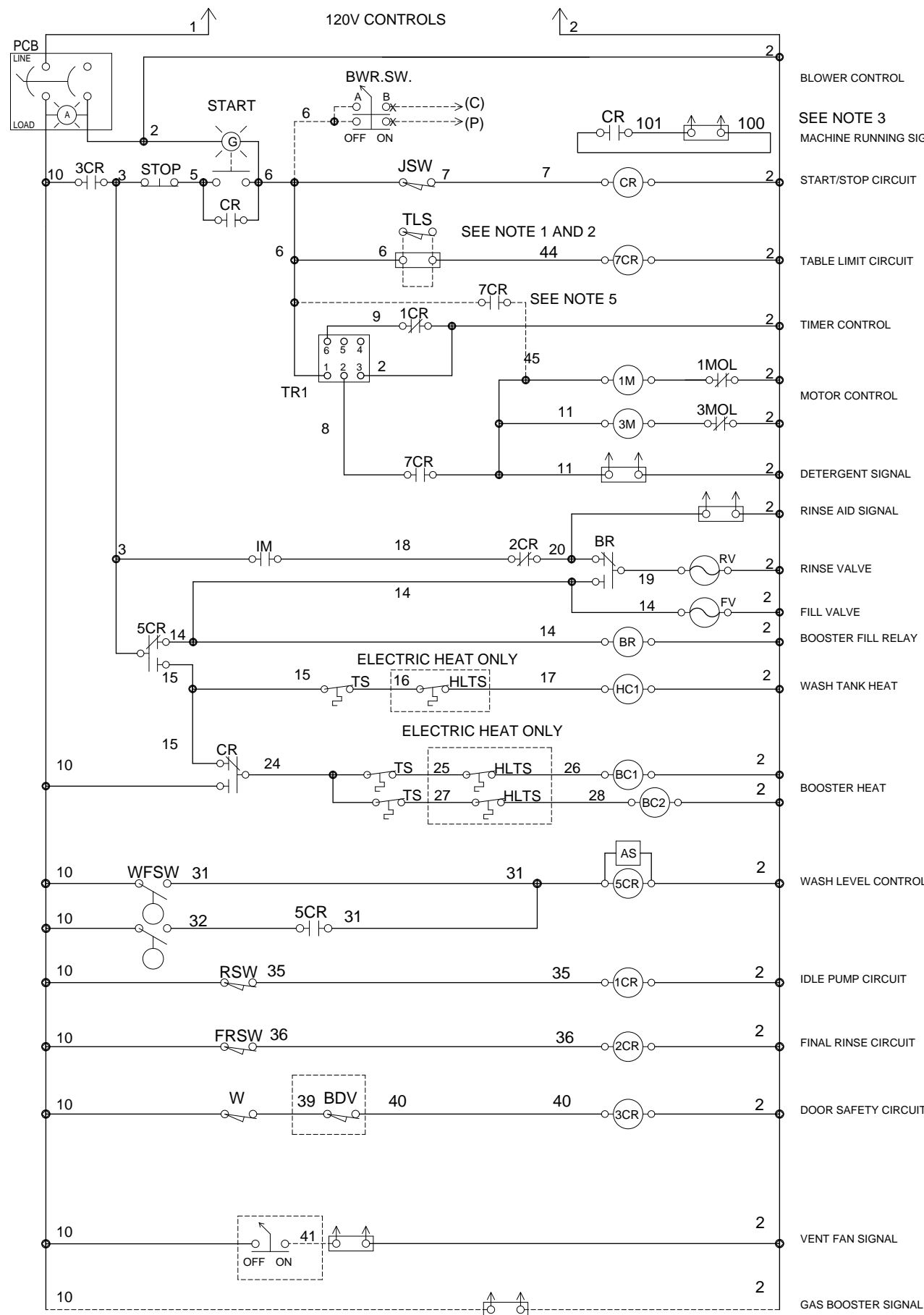
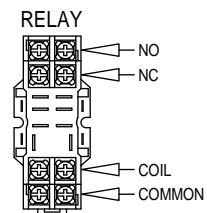

3 PHASE WIRING

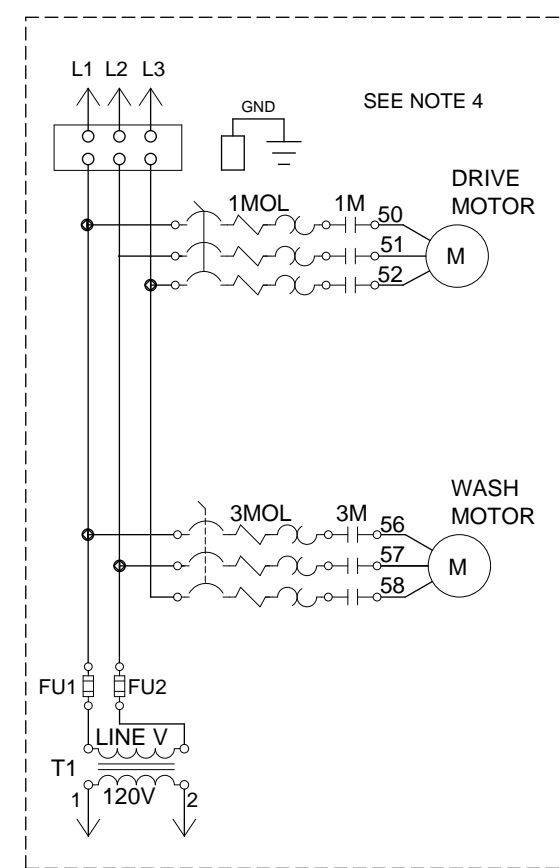

SINGLE PHASE WIRING

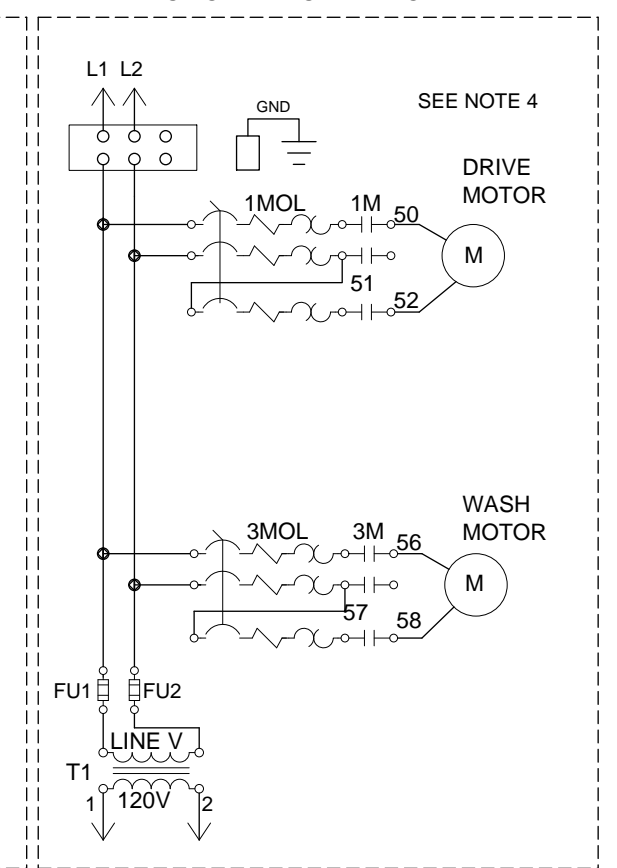

BLOWER/DRYER MOTOR

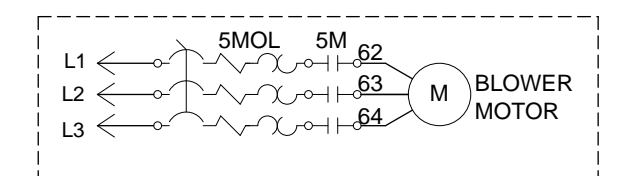

TANK HEAT

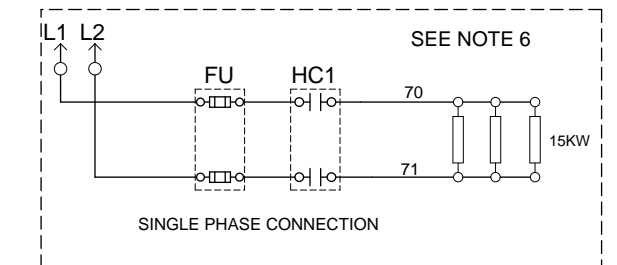
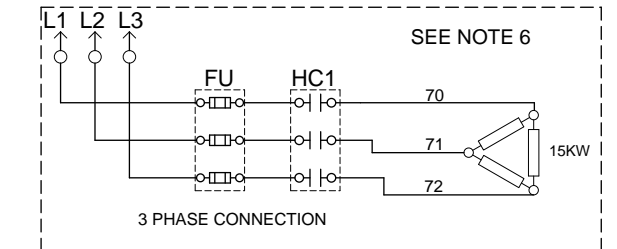

CUSTOMER TO SUPPLY RATED VOLTAGE/PHASE/Hz, AS SPECIFIED PER ORDER, TO DISCONNECT SWITCH. ALL POWER SUPPLIED TO EACH CONNECTION POINT MUST COMPLY WITH ALL LOCAL ELECTRIC CODES.			
DR.BY	J.MCALLISTER	SCALE	NONE
DATE	17OCT03	SHEET	1 OF 1

REV.	DESCRIPTION	DATE	BY
A	REVISED NOTES TO INCLUDE TLS WIRE LOCATION	9JUL04	JAM
B	REMOVED JUMPER FOR BR RELAY	9AUG04	JAM
C	ADDED NOTE 5 ADDED WIRING FOR SIDELOADER	27SEP04	JAM

REV.	DESCRIPTION	DATE	BY
D	MOVED TABLE LIMIT CIRCUIT	1DEC04	JAM
E	MOVED RINSE AID CIRCUIT	5JAN05	JAM

Champion
The Dishwashing Machine Specialists

**SINGLE TANK RACK CONVEYOR
STEAM/ELECTRIC HEAT**

B 701820 REV. **E**

MODELS COVERED BY THIS DRAWING	
64	
72	
84	

NOTES:

- 7CR IS USED ONLY WITH A TABLE LIMIT SWITCH OR MRA TABLE. WHEN A TABLE LIMIT SWITCH IS NOT USED INSTALL JUMPER.
- WHEN TABLE LIMIT SWITCH OR MRA IS USED, CONNECT SWITCHES BETWEEN WIRES 6 AND 44 ON TERMINAL BLOCK IN PANEL.
- USED FOR MACHINE RUNNING SIGNAL.
- DRIVE MOTOR CONNECTED SINGLE PHASE FOR 200-240 VOLT MODELS.
- ON MODELS WITH SIDE LOADER OPTION DRIVE MOTOR CONTACTOR 1M IS CONNECTED TO WIRE #45 INSTEAD OF WIRE #11.
- ON MODELS WITH MULTIPLE ELECTRIC CONNECTIONS, MAKE HEATER POWER CONNECTIONS AT THE HEATER FUSE BLOCK.

1CR	RACK SWITCH RELAY
2CR	FINAL RINSE SWITCH RELAY
3CR	DOOR SAFETY SWITCH RELAY
4CR	RINSE FILL RELAY
5CR	WASH FILL RELAY
7CR	TABLE LIMIT SWITCH RELAY
1M	DRIVE MOTOR CONTACTOR
1MOL	DRIVE MOTOR OVERLOAD
3M	WASH MOTOR CONTACTOR
3MOL	WASH MOTOR OVERLOAD
4M	RINSE MOTOR CONTACTOR
4MOL	RINSE MOTOR OVERLOAD
5M	BLOWER MOTOR CONTACTOR
5MOL	BLOWER MOTOR OVERLOAD
AS	ARC SUPPRESSOR
BC-	BOOSTER CONTACTOR/STEAM VALVE
BDV	BLOWER DOOR SWITCH
BR	BOOSTER RELAY
BWR.SW.	BLOWER SWITCH
CR	HOLD-IN RELAY
FRFV	FINAL RINSE FILL VALVE
FRSW	FINAL RINSE SWITCH
FU_	FUSE
HC-	HEAT CONTACTOR/STEAM VALVE
HLTS	HIGH LIMIT THERMOSTAT
JSW	JAM SWITCH
PCB	POWER SWITCH/CIRCUIT BREAKER
R	RINSE DOOR SWITCH
RFSW	RINSE TANK FLOAT SWITCH
RSW	RACK SWITCH
T1	CONTROL TRANSFORMER
TLS	TABLE LIMIT SWITCH
TR1	IDLE PUMP TIMER
TS	THERMOSTAT
W	WASH DOOR SWITCH
WFSW	WASH TANK FLOAT SWITCH
WV	WASH FILL VALVE

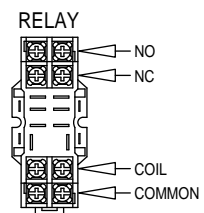
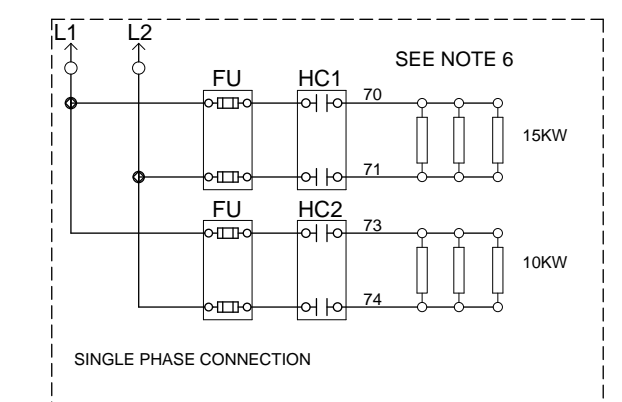
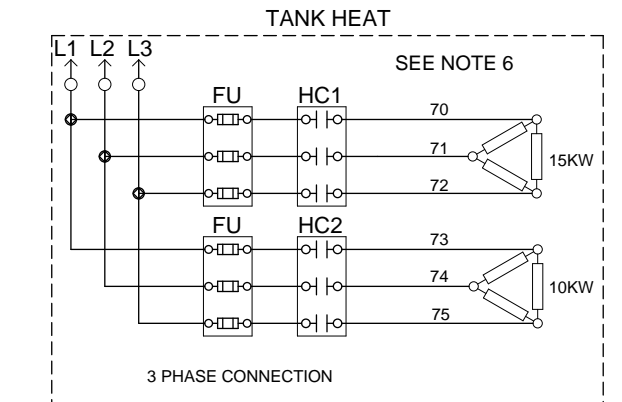
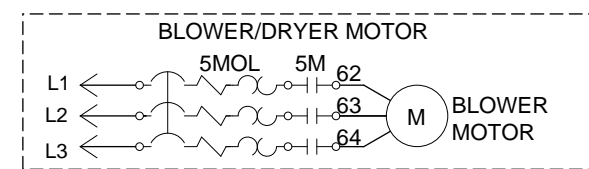
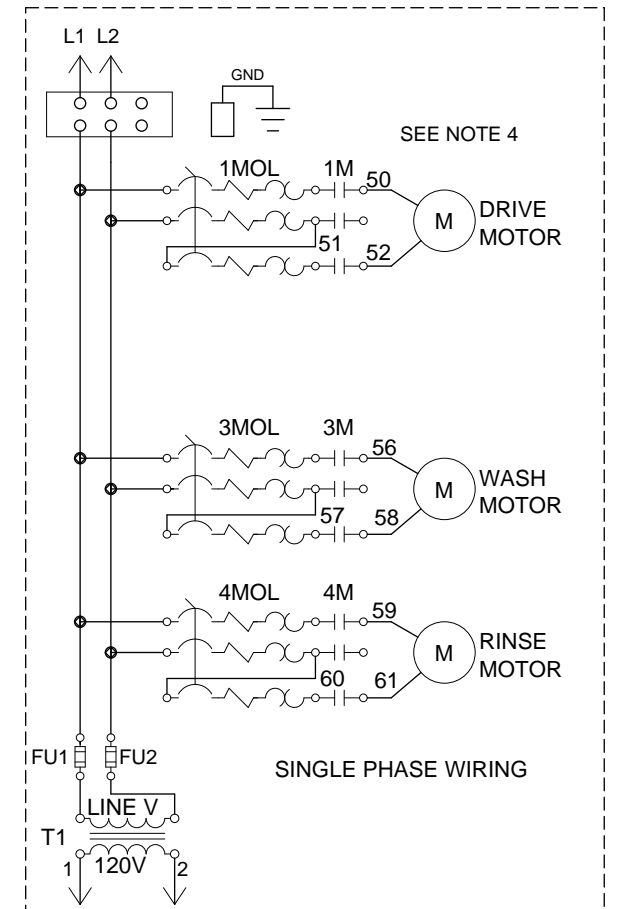
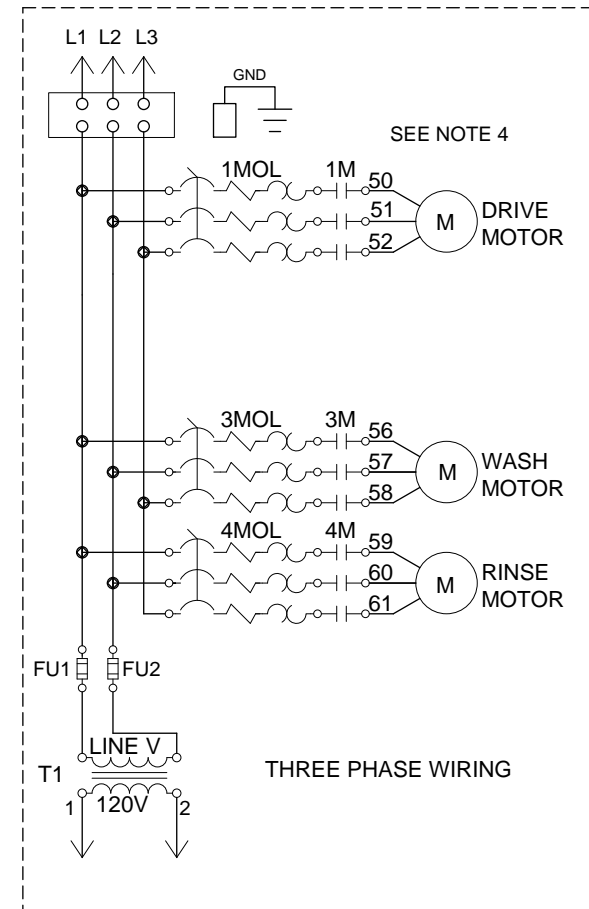
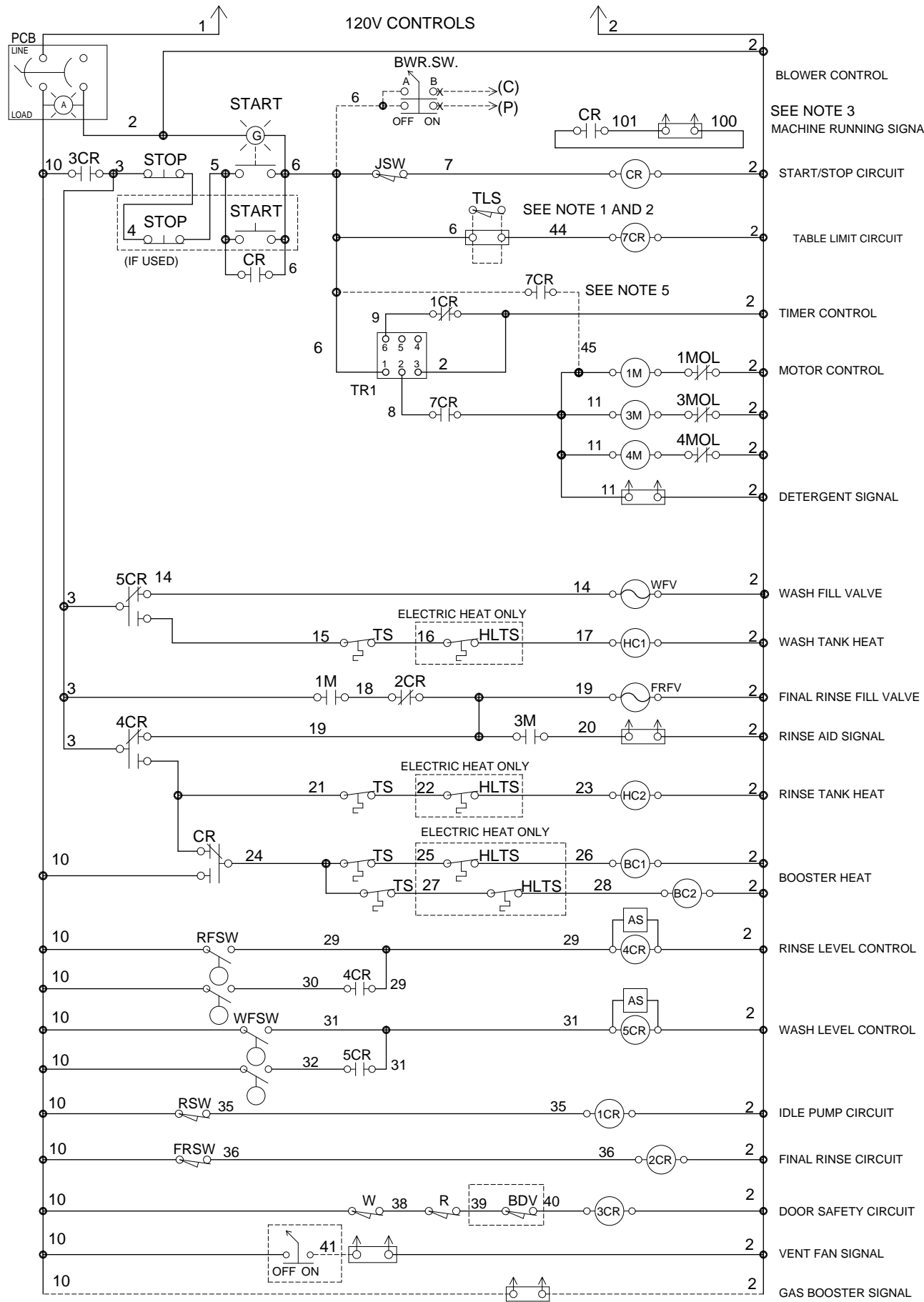

DIAGRAM STATE
POWER OFF
DOORS CLOSED
TANKS EMPTY



CUSTOMER TO SUPPLY RATED VOLTAGE/PHASE/HZ, AS SPECIFIED PER ORDER, TO DISCONNECT SWITCH. ALL POWER SUPPLIED TO EACH CONNECTION POINT MUST COMPLY WITH ALL LOCAL ELECTRIC CODES.			
DR.BY	J.MCALLISTER	SCALE	NONE
DATE	24OCT03	SHEET	1 OF 1

REV.	DESCRIPTION	DATE	BY
A	REVISED NOTES TO INCLUDE TLS WIRE LOCATION	14JUN04	JAM
B	ADDED NOTE 5 ADDED WIRING FOR SIDELoader	27SEP04	JAM
C	MOVED TABLE LIMIT SWITCH CIRCUIT	02DEC04	JAM

REV.	DESCRIPTION	DATE	BY

The Dishwashing Machine Specialists

**TWO TANK RACK CONVEYOR
STEAM/ELECTRIC HEAT**

B 701827

REV. **C**

MODELS COVERED BY THIS DRAWING	
66 PW	80 LT HDPW
70 FFPW	76 PW
80 HDPW	80 FFPW
66 LT PW	90 HDPW
70 LT FFPW	

NOTES:

- 7CR IS USED ONLY WITH A TABLE LIMIT SWITCH OR MRA TABLE. WHEN A TABLE LIMIT SWITCH IS NOT USED INSTALL JUMPER.
- WHEN TABLE LIMIT SWITCH OR MRA IS USED, CONNECT SWITCHES BETWEEN WIRES 6 AND 44 ON TERMINAL BLOCK IN PANEL.
- USED FOR MACHINE RUNNING SIGNAL.
- DRIVE MOTOR CONNECTED SINGLE PHASE FOR 200-240 VOLT MODELS.
- ON MODELS WITH SIDE LOADER OPTION DRIVE MOTOR CONTACTOR 1M IS CONNECTED TO WIRE #45 INSTEAD OF WIRE #1.
- ON MODELS WITH MULTIPLE ELECTRIC CONNECTIONS, MAKE HEATER POWER CONNECTIONS AT THE HEATER FUSE BLOCK.

1CR	RACK SWITCH RELAY
2CR	FINAL RINSE SWITCH RELAY
3CR	DOOR SAFETY SWITCH RELAY
5CR	WASH FILL RELAY
6CR	PREWASH FILL RELAY
7CR	TABLE LIMIT SWITCH RELAY
1M	DRIVE MOTOR CONTACTOR
1MOL	DRIVE MOTOR OVERLOAD
2M	PREWASH MOTOR CONTACTOR
2MOL	PREWASH MOTOR OVERLOAD
3M	WASH MOTOR CONTACTOR
3MOL	WASH MOTOR OVERLOAD
5M	BLOWER MOTOR CONTACTOR
5MOL	BLOWER MOTOR OVERLOAD
AS	ARC SUPPRESSOR
BC-	BOOSTER CONTACTOR/STEAM VALVE
BDV	BLOWER DOOR SWITCH
BR	BOOSTER RELAY
BWR.SW.	BLOWER SWITCH
CR	HOLD-IN RELAY
CWTS	COLD WATER THERMOSTAT
CWV	COLD WATER VALVE
FRSW	FINAL RINSE SWITCH
FU	FUSE/FUSE BLOCK
FV	FILL VALVE
HC-	HEAT CONTACTOR/STEAM VALVE/HOT WATER PUMP
HLTS	HIGH LIMIT THERMOSTAT
JSW	JAM SWITCH
PCB	POWER SWITCH/CIRCUIT BREAKER
PW	PREWASH DOOR SWITCH
PWFV	PREWASH FILL VALVE
PWFWSW	PREWASH TANK FLOAT SWITCH
RSW	RACK SWITCH
RV	RINSE VALVE
T1	CONTROL TRANSFORMER
TLS	TABLE LIMIT SWITCH
TR1	IDLE PUMP TIMER
TS	THERMOSTAT
W	WASH DOOR SWITCH
WFSW	WASH TANK FLOAT SWITCH

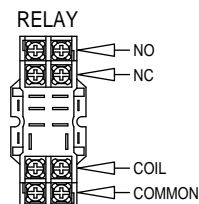
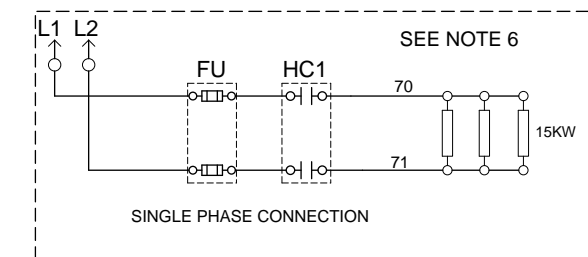
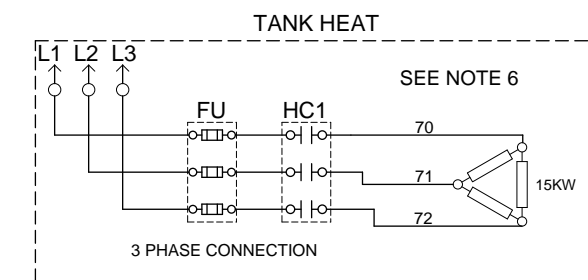
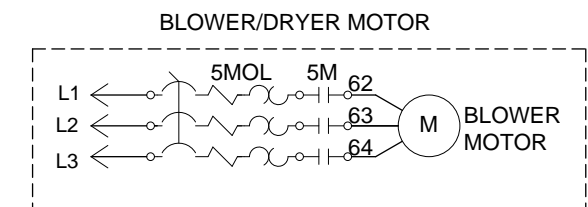
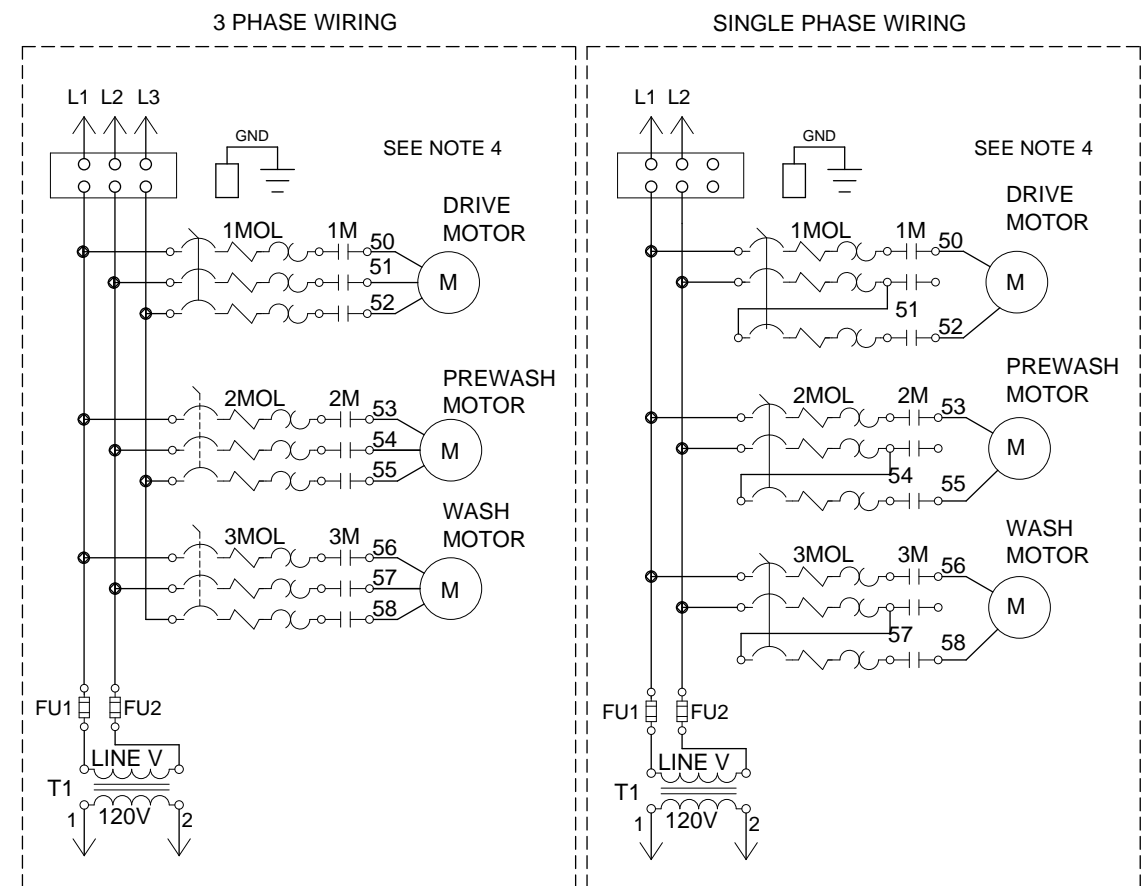
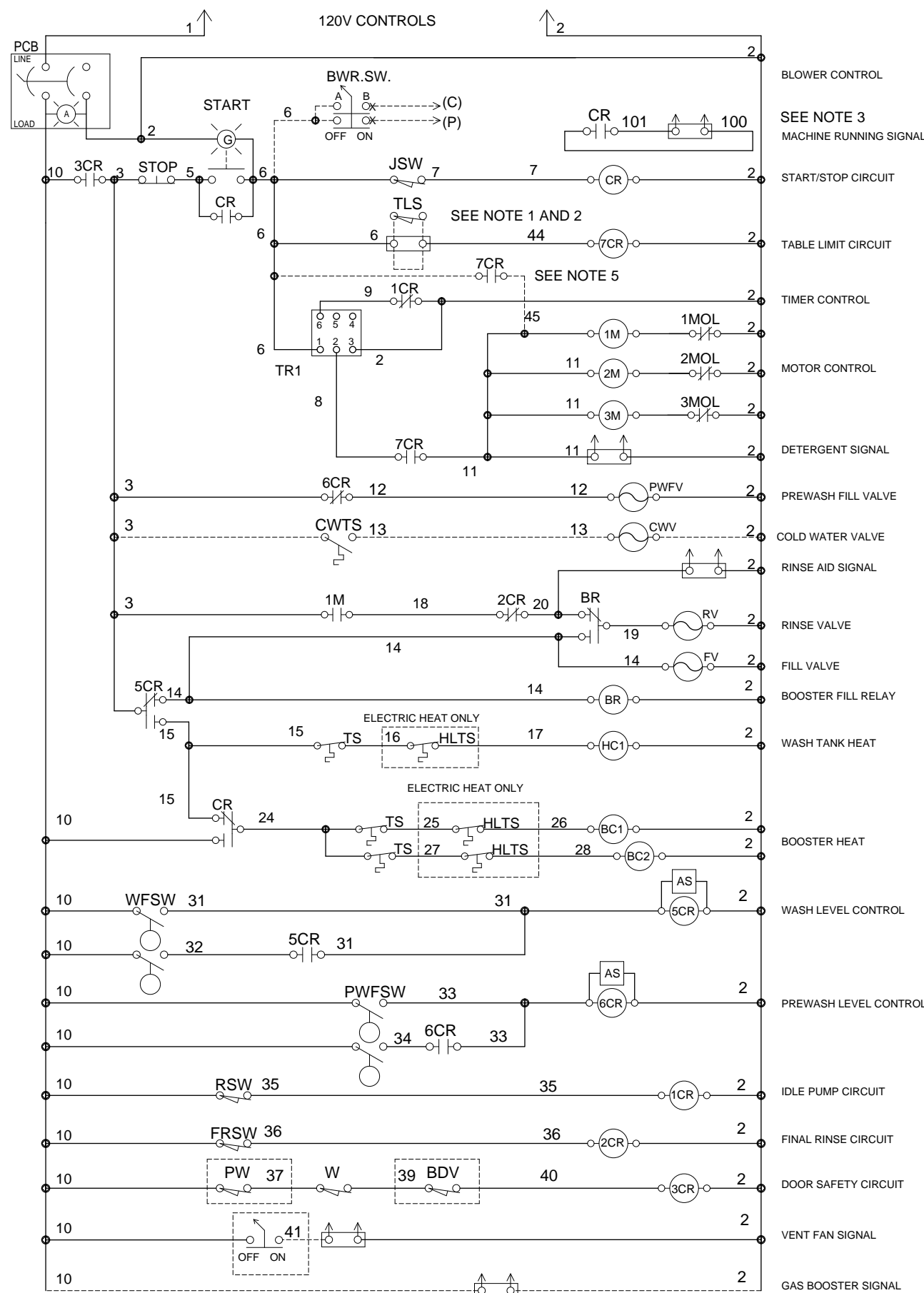

DIAGRAM STATE
POWER OFF
DOORS CLOSED
TANKS EMPTY



CUSTOMER TO SUPPLY RATED VOLTAGE/PHASE/Hz, AS SPECIFIED PER ORDER TO DISCONNECT SWITCH. ALL POWER SUPPLIED TO EACH CONNECTION POINT MUST COMPLY WITH ALL LOCAL ELECTRIC CODES.			
DR.BY	J.MCALLISTER	SCALE	NONE
DATE	17OCT03	SHEET	1 OF 1

REV.	DESCRIPTION	DATE	BY
A	REVISED NOTES TO INCLUDE TLS WIRE LOCATION	14JUN04	JAM
B	ADDED NOTE 5 ADDED WIRING FOR SIDELoader	27SEP04	JAM
C	MOVED TABLE LIMIT CIRCUIT	1DEC04	JAM

REV.	DESCRIPTION	DATE	BY
D	MOVED CWTS AND PREWASH FILL CIRCUIT	5JAN05	JAM

<p>The Dishwashing Machine Specialists</p>	SINGLE TANK RACK CONVEYOR WITH PREWASH, STEAM/ELECTRIC/HOT WATER HEAT	
	B	701831
		REV. D

CUSTOMER TO SUPPLY RATED VOLTAGE/PHASE/HZ, AS SPECIFIED PER ORDER TO DISCONNECT SWITCH. ALL POWER SUPPLIED TO EACH CONNECTION POINT MUST COMPLY WITH ALL LOCAL ELECTRIC CODES.			
DR. BY	J.MCALLISTER	SCALE	NONE
DATE	17OCT03	SHEET	1 OF 1

REV.	DESCRIPTION	DATE	BY
A	REVISED NOTES TO INCLUDE TLS WIRE LOCATION	14JUN04	JAM
B	ADDED NOTE 5 ADDED WIRING FOR SIDeloader	27SEP04	JAM
C	MOVED TABLE LIMIT SWITCH CIRCUIT	02DEC04	JAM

REV.	DESCRIPTION	DATE	BY

Champion
The Dishwashing Machine Specialists

TWO TANK RACK CONVEYOR WITH PREWASH, STEAM/ELECTRIC HEAT		REV. C
B	701834	

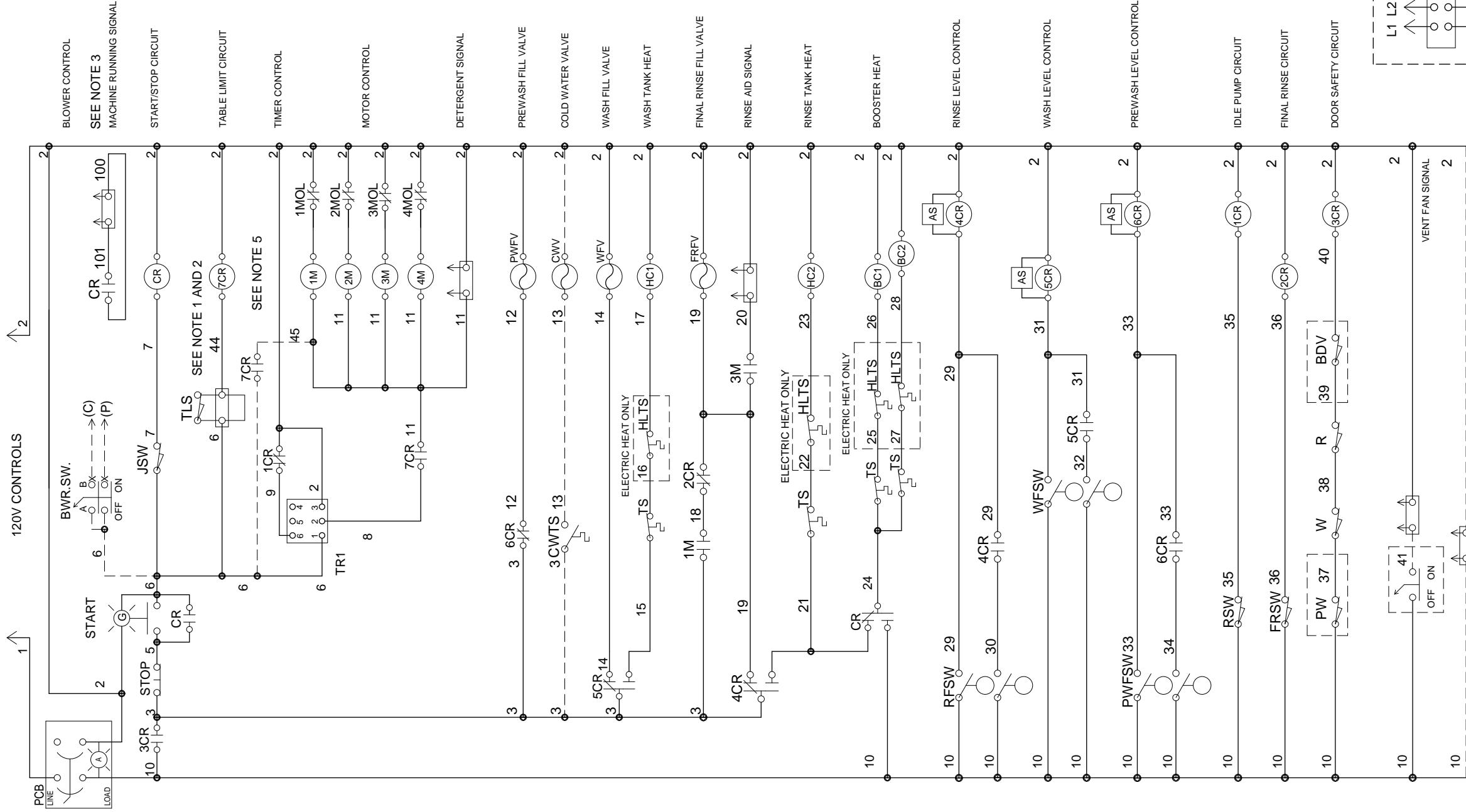

MODELS COVERED BY THIS DRAWING	
86 PW	108 HDPW
90 FFPW	106 PW
100 HDPW	110 FFPW
94 PW	120 HDPW
98 FFPW	

1CR	RACK SWITCH RELAY
2CR	FINAL RINSE SWITCH RELAY
3CR	DOOR SAFETY SWITCH RELAY
4CR	RINSE FILL RELAY
5CR	WASH FILL RELAY
6CR	PREWASH FILL RELAY
7CR	TABLE LIMIT SWITCH RELAY
1M	DRIVE MOTOR CONTACTOR
1MOL	DRIVE MOTOR OVERLOAD
2M	PREWASH MOTOR CONTACTOR
2MOL	PREWASH MOTOR OVERLOAD
3M	WASH MOTOR CONTACTOR
3MOL	WASH MOTOR OVERLOAD
4M	RINSE MOTOR CONTACTOR
4MOL	RINSE MOTOR OVERLOAD
5M	BLOWER MOTOR CONTACTOR
5MOL	BLOWER MOTOR OVERLOAD
AS	ARC SUPPRESSOR
BC-	BOOSTER CONTACTOR/STEAM VALVE
BDV	BLOWER DOOR SWITCH
BWR.SW.	BLOWER SWITCH
CR	HOLD-IN RELAY
CWTS	COLD WATER THERMOSTAT
CWV	COLD WATER VALVE
FRSW	FINAL RINSE SWITCH
FU	FUSE/FUSE BLOCK
FRFV	FINAL RINSE FILL VALVE
FRSW	FINAL RINSE SWITCH
HC-	HEAT CONTACTOR/STEAM VALVE
HLTS	HIGH LIMIT THERMOSTAT
JSW	JAM SWITCH
PCB	POWER SWITCH/CIRCUIT BREAKER
PW	PREWASH DOOR SWITCH
PWFV	PREWASH FILL VALVE
PWFSW	PREWASH FLOAT SWITCH
R	RINSE DOOR SWITCH
RFSW	RINSE TANK FLOAT SWITCH
RSW	RACK SWITCH
T1	CONTROL TRANSFORMER
TLS	TABLE LIMIT SWITCH
TR1	IDLE PUMP TIMER
TS	THERMOSTAT
W	WASH DOOR SWITCH
WFSW	WASH TANK FLOAT SWITCH
WV	WASH FILL VALVE

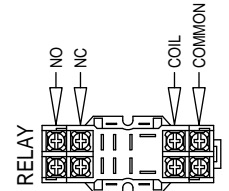
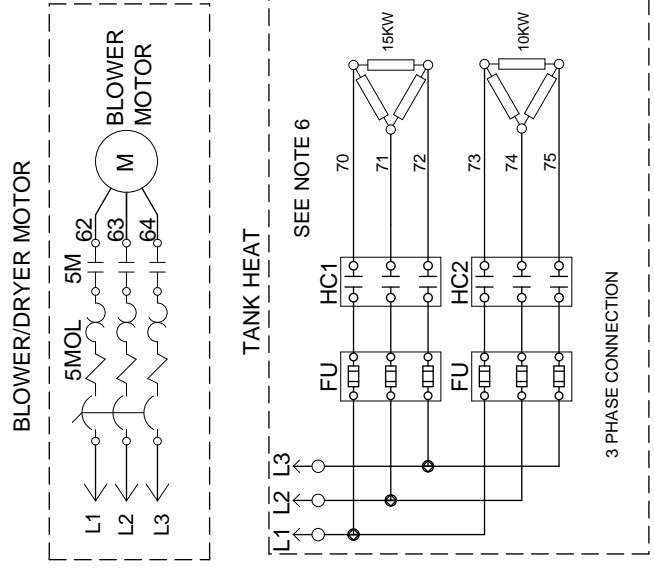
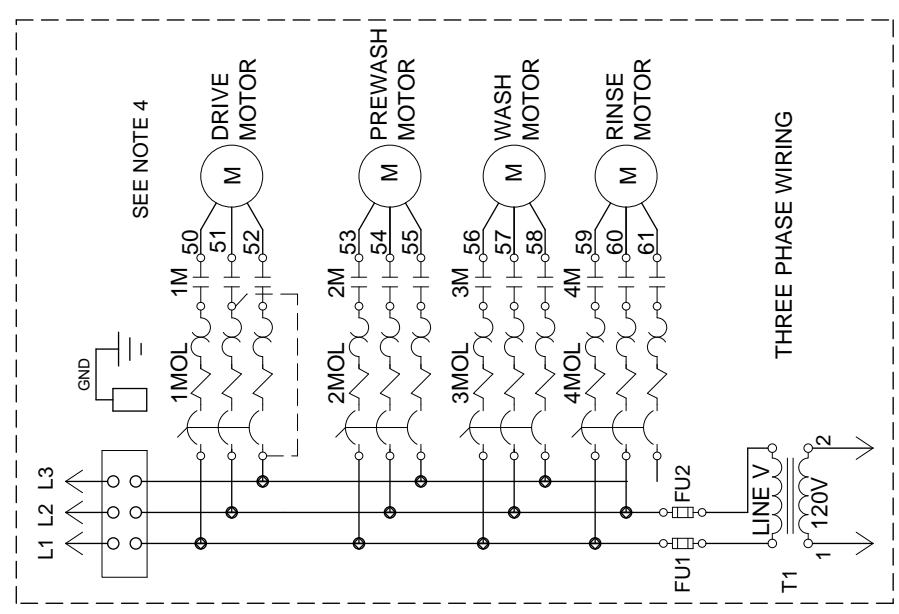

DIAGRAM STATE
POWER OFF
DOORS CLOSED
TANKS EMPTY

- NOTES:
- 7CR IS USED ONLY WITH A TABLE LIMIT SWITCH OR MRA TABLE.
 - WHEN A TABLE LIMIT SWITCH OR MRA IS NOT USED, INSTALL JUMPER.
 - WHEN TABLE LIMIT SWITCH OR MRA IS USED, CONNECT SWITCHES BETWEEN WIRES 6 AND 44 ON TERMINAL BLOCK IN PANEL.
 - USED FOR MACHINE RUNNING SIGNAL.
 - DRIVE MOTOR CONNECTED SINGLE PHASE FOR 200-240 VOLT MODELS.
 - ON MODELS WITH SIDE LOADER OPTION DRIVE MOTOR CONTACTOR 1M IS CONNECTED TO WIRE #45 INSTEAD OF WIRE #11.
 - ON MODELS WITH MULTIPLE ELECTRIC CONNECTIONS, MAKE HEATER POWER CONNECTIONS AT THE HEATER FUSE BLOCK.

MODELS COVERED BY THIS DRAWING	
44 WS	70 WS FFPW
66 WS PW	80 WS HDPW

NOTES:

- 7CR IS USED ONLY WITH A TABLE LIMIT SWITCH OR MRA TABLE. WHEN A TABLE LIMIT SWITCH IS NOT USED INSTALL JUMPER.
- WHEN TABLE LIMIT SWITCH OR MRA IS USED, CONNECT SWITCHES BETWEEN WIRES 6 AND 44 ON TERMINAL BLOCK IN PANEL.
- USED FOR MACHINE RUNNING SIGNAL.
- DRIVE MOTOR CONNECTED SINGLE PHASE FOR 200-240 VOLT MODELS.
- ON MODELS WITH SIDE LOADER OPTION DRIVE MOTOR CONTACTOR 1M IS CONNECTED TO WIRE #45 INSTEAD OF WIRE #11.
- ON MODELS WITH MULTIPLE ELECTRIC CONNECTIONS, MAKE HEATER POWER CONNECTIONS AT THE HEATER FUSE BLOCK.

1CR	RACK SWITCH RELAY
2CR	FINAL RINSE SWITCH RELAY
3CR	DOOR SAFETY SWITCH RELAY
5CR	WASH FILL RELAY
6CR	PREWASH FILL RELAY
7CR	TABLE LIMIT SWITCH RELAY
1M	DRIVE MOTOR CONTACTOR
1MOL	DRIVE MOTOR OVERLOAD
2M	PREWASH MOTOR CONTACTOR
2MOL	PREWASH MOTOR OVERLOAD
3M	WASH MOTOR CONTACTOR
3MOL	WASH MOTOR OVERLOAD
5M	BLOWER MOTOR CONTACTOR
5MOL	BLOWER MOTOR OVERLOAD
AS	ARC SUPPRESSOR
BC-	BOOSTER CONTACTOR/STEAM VALVE
BDV	BLOWER DOOR SWITCH
BR	BOOSTER RELAY
BWR.SW.	BLOWER SWITCH
CR	HOLD-IN RELAY
CWTS	COLD WATER THERMOSTAT
CWV	COLD WATER VALVE
FRSW	FINAL RINSE SWITCH
FU	FUSE/FUSE BLOCK
FV	FILL VALVE
HC-	HEAT CONTACTOR/STEAM VALVE
HLTS	HIGH LIMIT THERMOSTAT
JSW	JAM SWITCH
PCB	POWER SWITCH/CIRCUIT BREAKER
PW	PREWASH DOOR SWITCH
PWFSW	PREWASH FLOAT SWITCH
PWFV	PREWASH FILL VALVE
RSW	RACK SWITCH
RV	RINSE VALVE
T1	CONTROL TRANSFORMER
TLS	TABLE LIMIT SWITCH
TR1	IDLE PUMP TIMER
TS	THERMOSTAT
W	WASH DOOR SWITCH
WFSW	WASH TANK FLOAT SWITCH

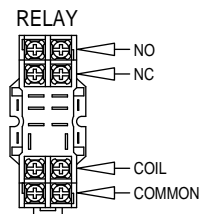
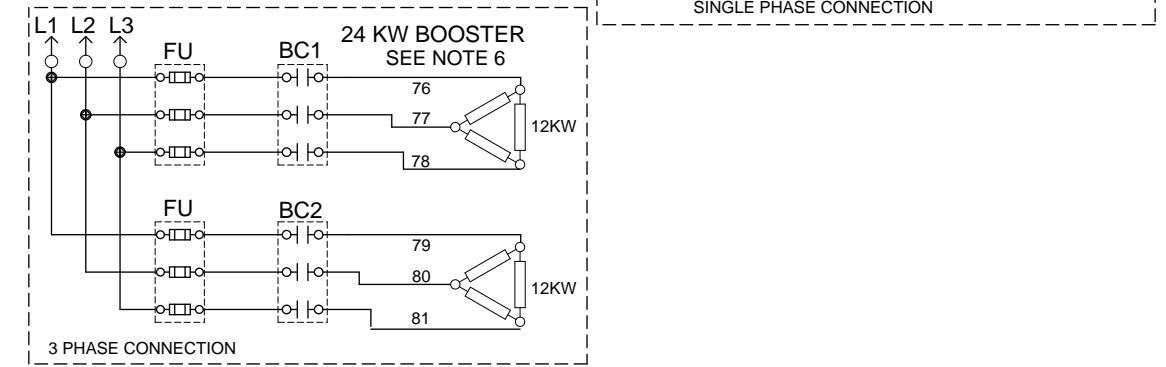
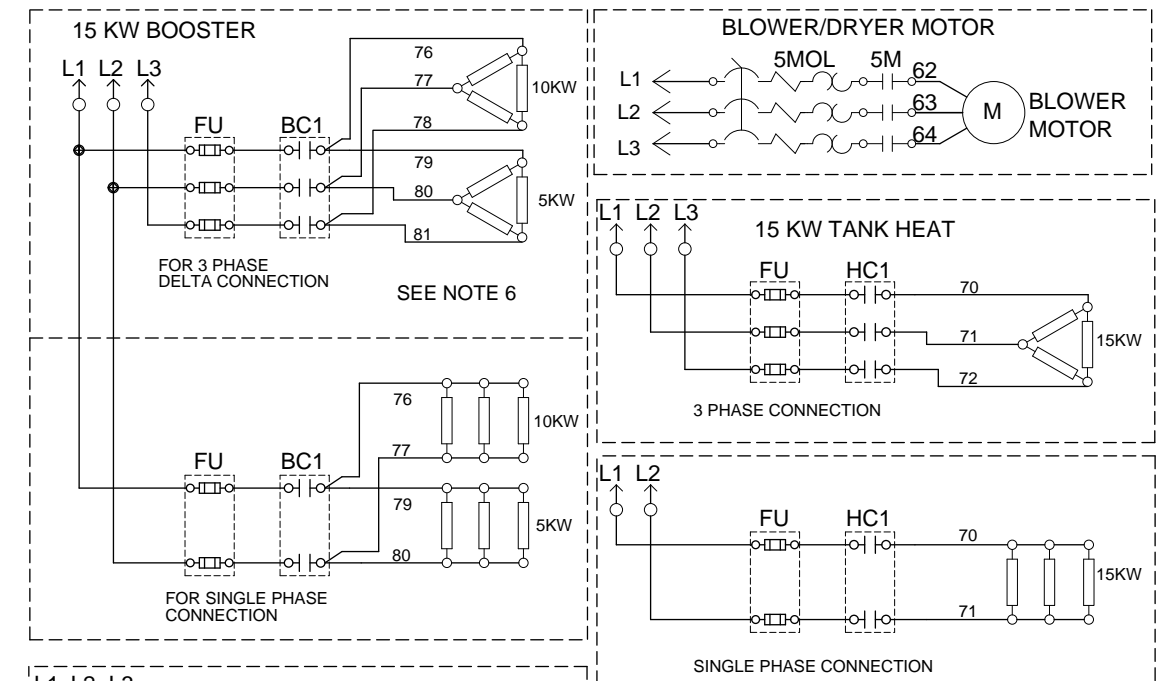
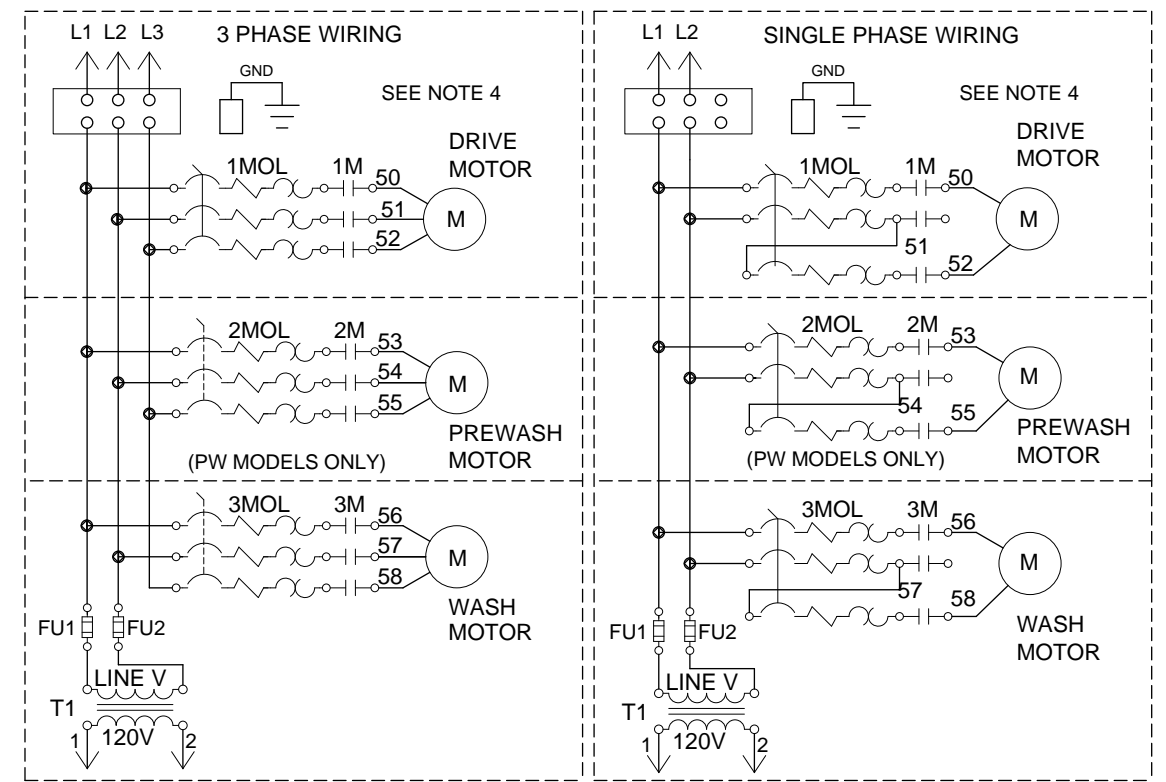
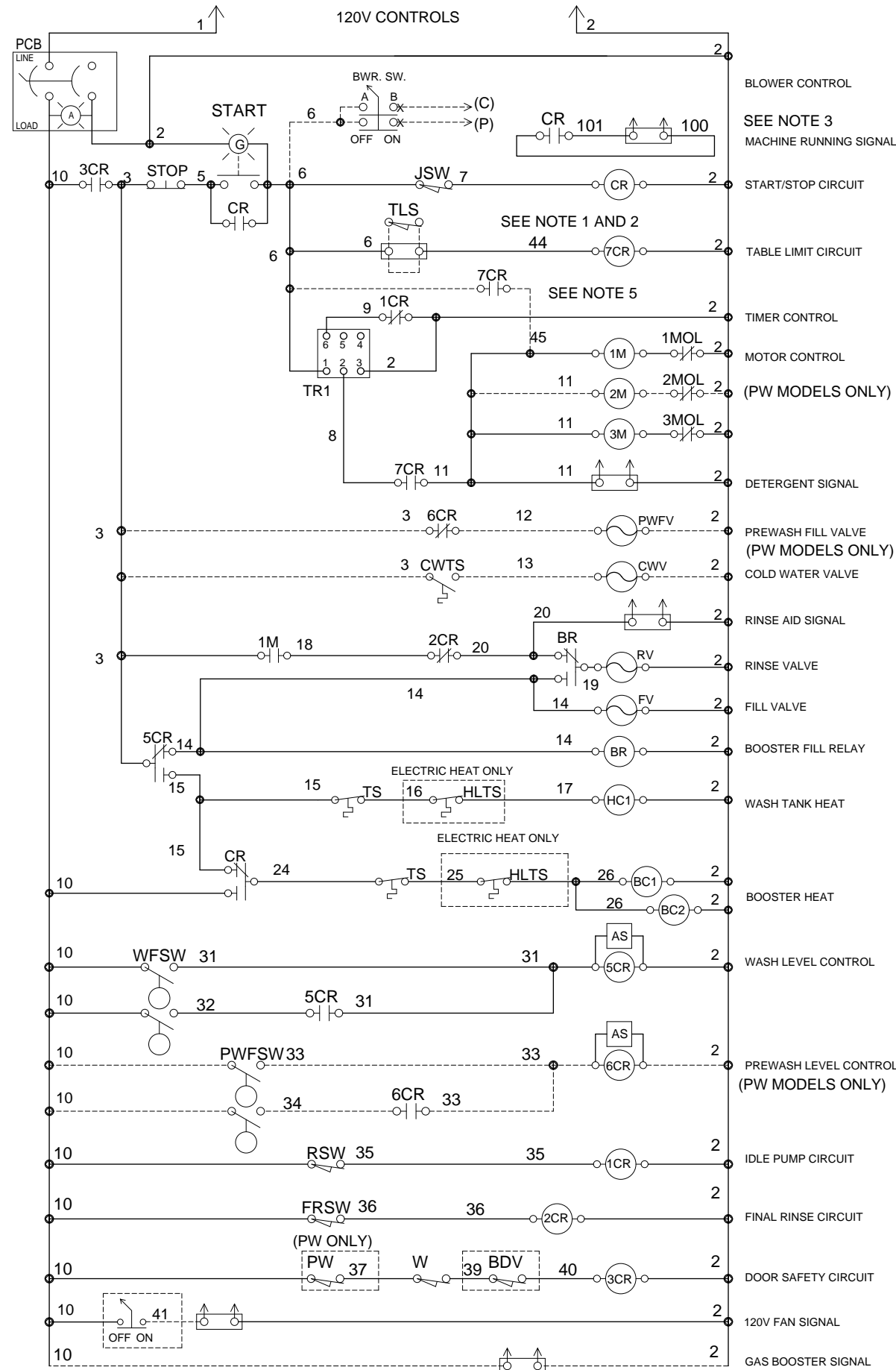

DIAGRAM STATE
POWER OFF
DOORS CLOSED
TANKS EMPTY



CUSTOMER TO SUPPLY RATED VOLTAGE/PHASE/HZ, AS SPECIFIED PER ORDER, TO DISCONNECT SWITCH. ALL POWER SUPPLIED TO EACH CONNECTION POINT MUST COMPLY WITH ALL LOCAL ELECTRIC CODES.			
DR.BY	J.MCALLISTER	SCALE	NONE
DATE	10FEB04	SHEET	1 OF 1

REV.	DESCRIPTION	DATE	BY
A	REVISED NOTES TO INCLUDE TLS WIRE LOCATION	14JUN04	JAM
B	ADDED NOTE 5 ADDED WIRING FOR SIDELoader	27SEP04	JAM
C	MOVED TABLE LIMIT SWITCH CIRCUIT	02DEC04	JAM

REV.	DESCRIPTION	DATE	BY
D	MOVED CWTS AND PREWASH FILL VALVE	10JAN05	JAM

Champion
The Dishwashing Machine Specialists

RACK CONVEYOR, WATER SAVER
STEAM/ELECTRIC HEAT

B 701843 **D**

3 PHASE CONNECTION

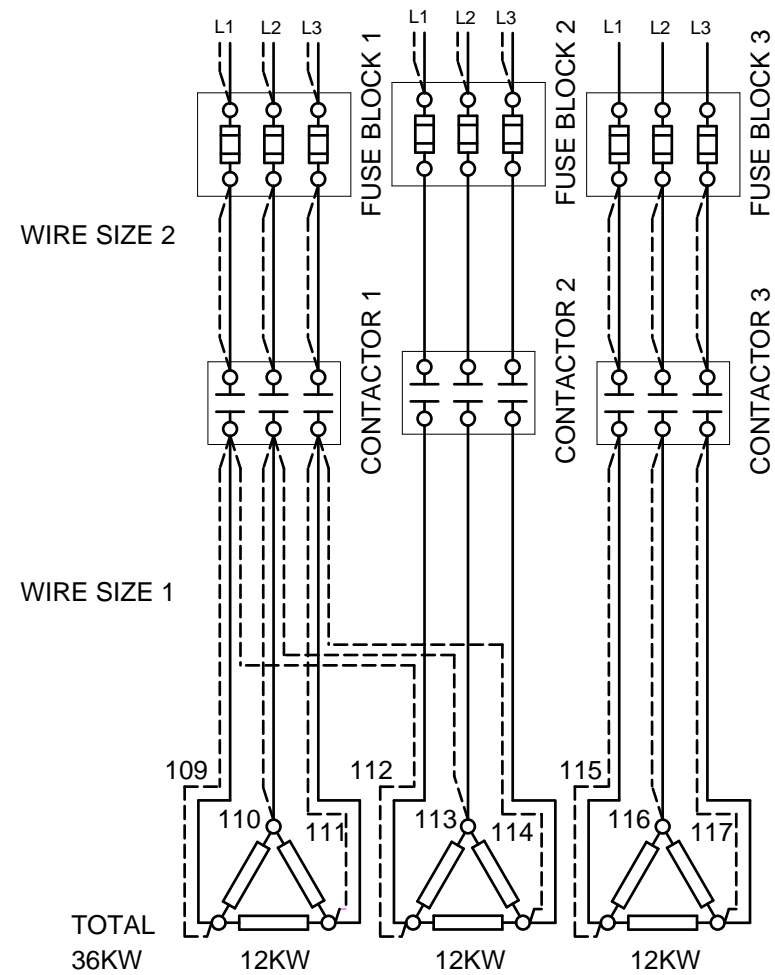

Y CONNECTION 380/415V ONLY

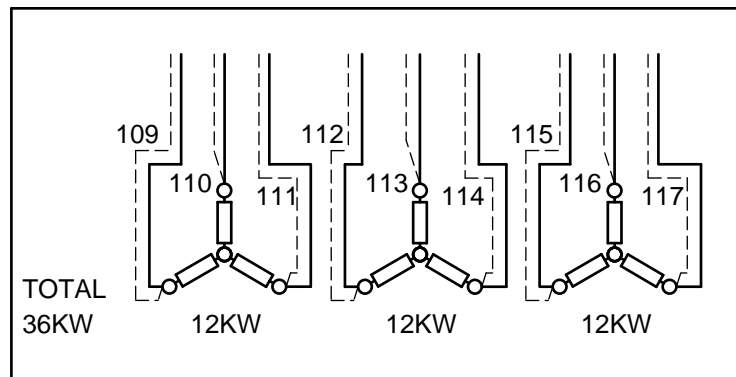

CANISTER 1 KW/CANISTER 36KW			
VOLTAGE 200-220V			
KW/CONTACTOR	12KW	12KW	12KW
CONTACTOR #	1	2	3
CONTACTOR RATING	60A	60A	60A
FUSE BLOCK #	1	2	3
FUSE RATING	45A	45A	45A
WIRE SIZE 1 AND 2	#8	#8	#8
CANISTER 1 KW/CANISTER 36KW			
VOLTAGE 230-240V			
KW/CONTACTOR	12KW	12KW	12KW
CONTACTOR #	1	2	3
CONTACTOR RATING	60A	60A	60A
FUSE BLOCK #	1	2	3
FUSE RATING	40A	40A	40A
WIRE SIZE 1 AND 2	#8	#8	#8
CANISTER 1 KW/CANISTER 36KW			
VOLTAGE 380V			
KW/CONTACTOR	24KW	12KW	
CONTACTOR #	1	3	
CONTACTOR RATING	60A	60A	
FUSE BLOCK #	1	3	
FUSE RATING	45A	25A	
WIRE SIZE 1	#12	#12	
WIRE SIZE 2	#10	#12	
CANISTER 1 KW/CANISTER 36KW			
VOLTAGE 415V			
KW/CONTACTOR	24KW	12KW	
CONTACTOR #	1	3	
CONTACTOR RATING	60A	60A	
FUSE BLOCK #	1	3	
FUSE RATING	45A	25A	
WIRE SIZE 1	#12	#12	
WIRE SIZE 2	#10	#12	
CANISTER 1 KW/CANISTER 36KW			
VOLTAGE 480V			
KW/CONTACTOR	24KW	12KW	
CONTACTOR #	1	3	
CONTACTOR RATING	60A	60A	
FUSE BLOCK #	1	2	
FUSE RATING	40A	20A	
WIRE SIZE 1	#14	#14	
WIRE SIZE 2	#10	#14	
CANISTER 1 KW/CANISTER 36KW			
VOLTAGE 575V			
KW/CONTACTOR	24KW	12KW	
CONTACTOR #	1	3	
CONTACTOR RATING	60A	60A	
FUSE BLOCK #	1	3	
FUSE RATING	30A	15A	
WIRE SIZE 1	#14	#14	
WIRE SIZE 2	#10	#14	

1 PHASE CONNECTION

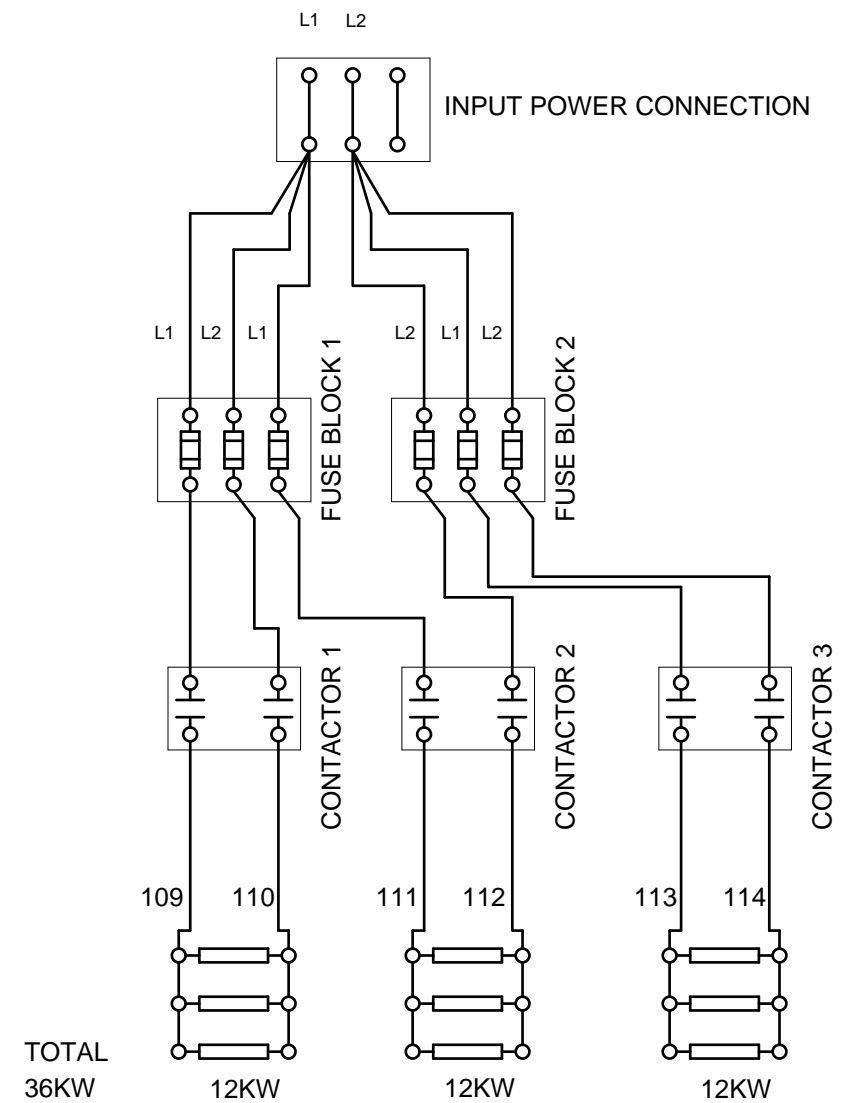

TOTAL 36KW

CANISTER 1 KW/CANISTER 36KW			
VOLTAGE 200-220V			
KW/CONTACTOR	12KW	12KW	12KW
CONTACTOR #	1	2	3
CONTACTOR RATING	75A	75A	75A
FUSE BLOCK #	1	2	3
FUSE RATING	70A	70A	70A
WIRE SIZE	#4	#4	#4
CANISTER 1 KW/CANISTER 36KW			
VOLTAGE 230-240V			
KW/CONTACTOR	12KW	12KW	12KW
CONTACTOR #	1	2	3
CONTACTOR RATING	75A	75A	75A
FUSE BLOCK #	1	2	3
FUSE RATING	70A	70A	70A
WIRE SIZE	#6	#6	#6

CUSTOMER TO SUPPLY RATED VOLTAGE/PHASE/Hz, AS SPECIFIED PER ORDER TO DISCONNECT SWITCH, ALL POWER SUPPLIED TO EACH CONNECTION POINT MUST COMPLY WITH ALL LOCAL ELECTRIC CODES.			
DR. BY	J.MCALLISTER	SCALE	
DATE	05APR04	SHEET	1 OF 1

REV.	DESCRIPTION	DATE	BY

REV.	DESCRIPTION	DATE	BY

<p>The Dishwashing Machine Specialists</p>		CH-36E, 36KW BOOSTER FOR RACK CONVEYOR MACHINES	
		B	701861

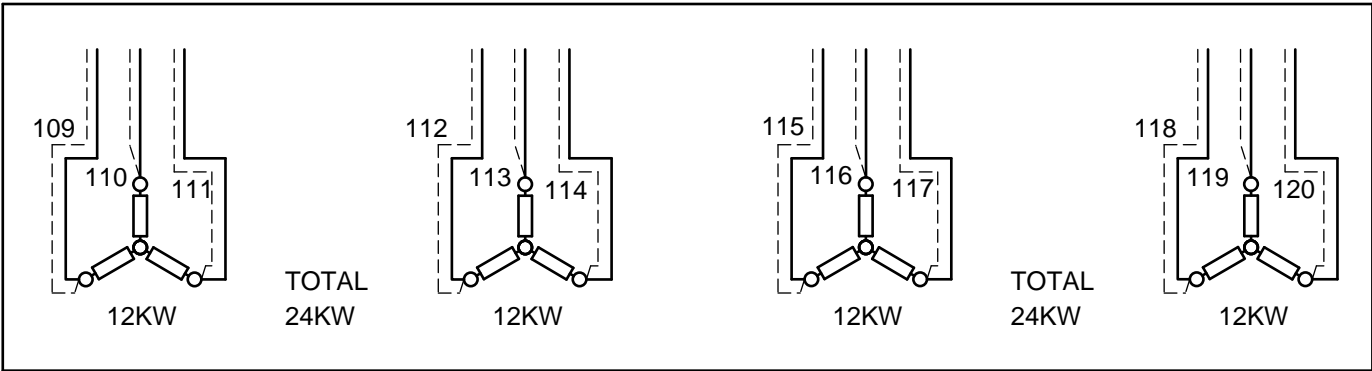
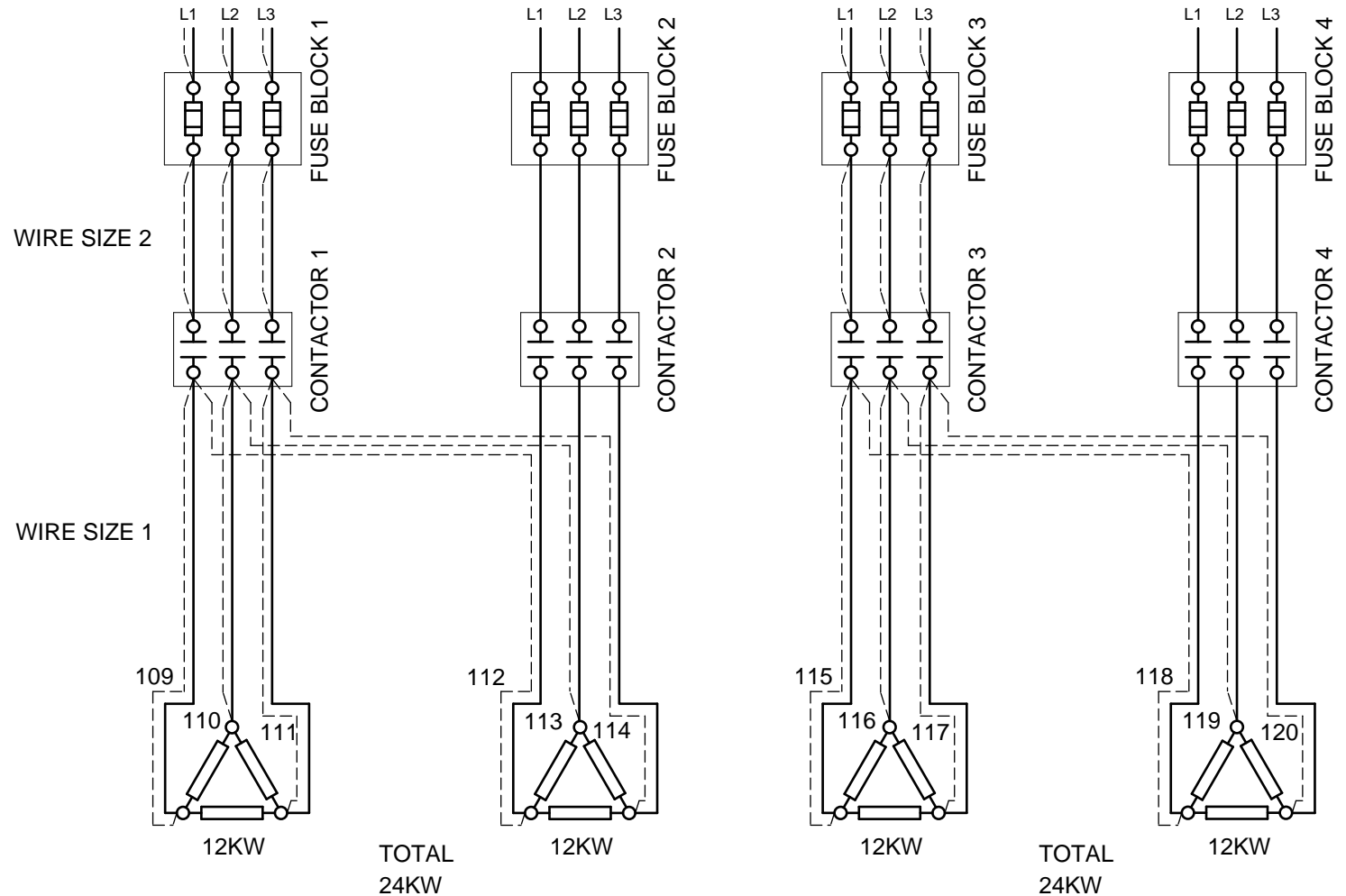

Y CONNECTION 380/415V ONLY

CANISTER 1 KW/CANISTER 24KW VOLTAGE 200-220V		CANISTER 2 KW/CANISTER 24KW VOLTAGE 200-220V	
KW/CONTACTOR	12KW	12KW	12KW
CONTACTOR #	1	2	4
CONTACTOR RATING	60A	60A	60A
FUSE BLOCK #	1	2	3
FUSE RATING	45A	45A	45A
WIRE SIZE 1 AND 2	#8	#8	#8
CANISTER 1 KW/CANISTER 24KW VOLTAGE 230-240V		CANISTER 2 KW/CANISTER 24KW VOLTAGE 230-240V	
KW/CONTACTOR	12KW	12KW	12KW
CONTACTOR #	1	2	4
CONTACTOR RATING	60A	60A	60A
FUSE BLOCK #	1	2	3
FUSE RATING	40A	40A	40A
WIRE SIZE 1 AND 2	#8	#8	#8
CANISTER 1 KW/CANISTER 24KW VOLTAGE 380V		CANISTER 2 KW/CANISTER 24KW VOLTAGE 380V	
KW/CONTACTOR	24KW	24KW	24KW
CONTACTOR #	1	3	3
CONTACTOR RATING	60A	60A	60A
FUSE BLOCK #	1	3	3
FUSE RATING	45A	45A	45A
WIRE SIZE 1	#12	#12	#12
WIRE SIZE 2	#10	#10	#10
CANISTER 1 KW/CANISTER 24KW VOLTAGE 415V		CANISTER 2 KW/CANISTER 24KW VOLTAGE 415V	
KW/CONTACTOR	24KW	27KW	27KW
CONTACTOR #	1	3	3
CONTACTOR RATING	60A	60A	60A
FUSE BLOCK #	1	3	3
FUSE RATING	45A	45A	45A
WIRE SIZE 1	#12	#12	#12
WIRE SIZE 2	#10	#10	#10
CANISTER 1 KW/CANISTER 24KW VOLTAGE 480V		CANISTER 2 KW/CANISTER 24KW VOLTAGE 480V	
KW/CONTACTOR	24KW	24KW	24KW
CONTACTOR #	1	3	3
CONTACTOR RATING	60A	60A	60A
FUSE BLOCK #	1	3	3
FUSE RATING	40A	40A	40A
WIRE SIZE 1	#14	#14	#14
WIRE SIZE 2	#10	#10	#10
CANISTER 1 KW/CANISTER 24KW VOLTAGE 575V		CANISTER 2 KW/CANISTER 24KW VOLTAGE 575V	
KW/CONTACTOR	24KW	24KW	24KW
CONTACTOR #	1	3	3
CONTACTOR RATING	60A	60A	60A
FUSE BLOCK #	1	3	3
FUSE RATING	30A	30A	30A
WIRE SIZE 1	#14	#14	#14
WIRE SIZE 2	#10	#10	#10

CUSTOMER TO SUPPLY RATED VOLTAGE/PHASE/HZ, AS SPECIFIED PER ORDER, TO DISCONNECT SWITCH. ALL POWER SUPPLIED TO EACH CONNECTION POINT MUST COMPLY WITH ALL LOCAL ELECTRIC CODES.

DR. BY	J.MCALLISTER	SCALE	
DATE	05APR04	SHEET	1 OF 1

REV.	DESCRIPTION	DATE	BY

REV.	DESCRIPTION	DATE	BY

 The Dishwashing Machine Specialists	CH-48E, 48KW BOOSTER FOR RACK CONVEYOR MACHINES	
	B 701862	REV.

3 PHASE CONNECTION

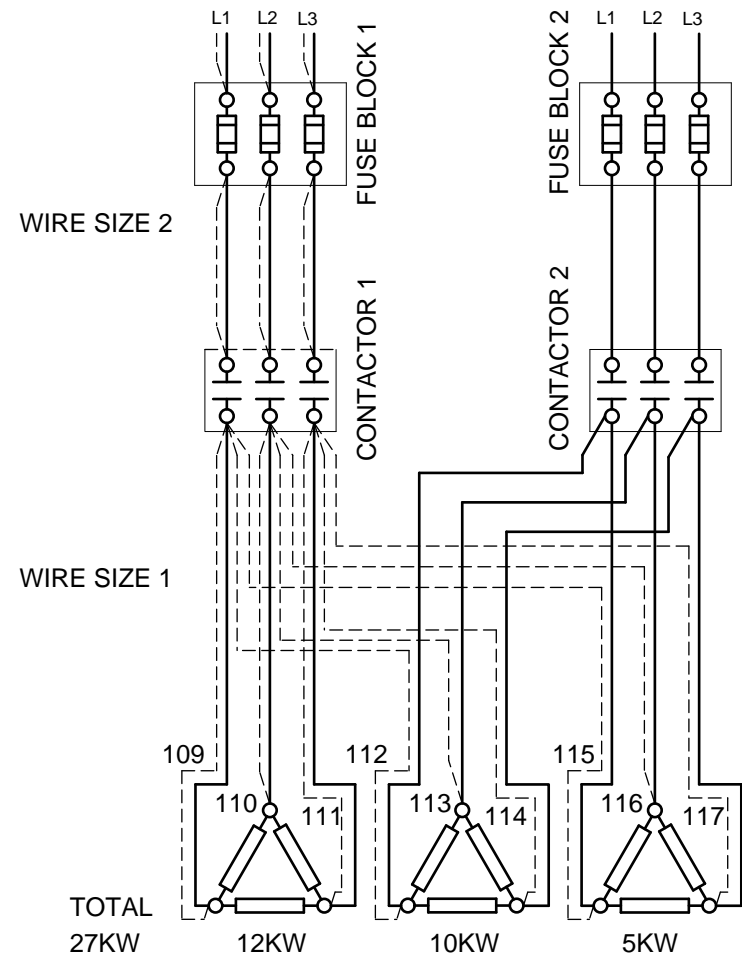

Y CONNECTION 380/415V ONLY

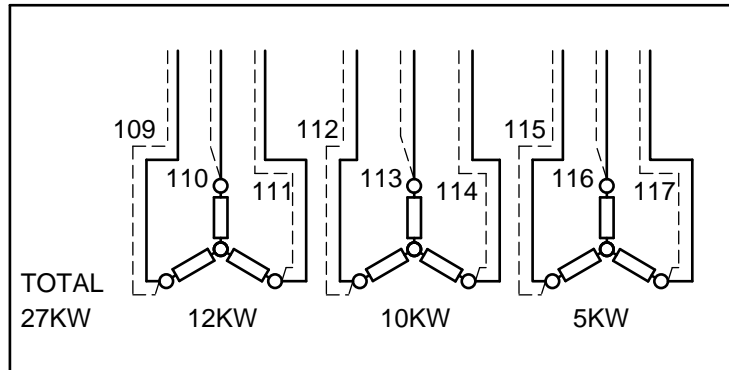

CANISTER 1 KW/CANISTER 27KW		VOLTAGE 200-220V	
KW/CONTACTOR	12KW	15KW	
CONTACTOR #	1	2	
CONTACTOR RATING	60A	60A	
FUSE BLOCK #	1	2	
FUSE RATING	45A	60A	
WIRE SIZE 1 AND 2	#8	#8	
CANISTER 1 KW/CANISTER 27KW		VOLTAGE 230-240V	
KW/CONTACTOR	12KW	15KW	
CONTACTOR #	1	2	
CONTACTOR RATING	60A	60A	
FUSE BLOCK #	1	2	
FUSE RATING	40A	50A	
WIRE SIZE 1 AND 2	#8	#8	
CANISTER 1 KW/CANISTER 27KW		VOLTAGE 380V	
KW/CONTACTOR	27KW		
CONTACTOR #	1		
CONTACTOR RATING	60A		
FUSE BLOCK #	1		
FUSE RATING	50A		
WIRE SIZE 1	#10		
WIRE SIZE 2	#10		
CANISTER 1 KW/CANISTER 27KW		VOLTAGE 415V	
KW/CONTACTOR	27KW		
CONTACTOR #	1		
CONTACTOR RATING	60A		
FUSE BLOCK #	1		
FUSE RATING	50A		
WIRE SIZE 1	#10		
WIRE SIZE 2	#10		
CANISTER 1 KW/CANISTER 27KW		VOLTAGE 480V	
KW/CONTACTOR	27KW		
CONTACTOR #	1		
CONTACTOR RATING	60A		
FUSE BLOCK #	1		
FUSE RATING	40A		
WIRE SIZE 1	#10		
WIRE SIZE 2	#10		
CANISTER 1 KW/CANISTER 27KW		VOLTAGE 575V	
KW/CONTACTOR	27KW		
CONTACTOR #	1		
CONTACTOR RATING	60A		
FUSE BLOCK #	1		
FUSE RATING	35A		
WIRE SIZE 1	#10		
WIRE SIZE 2	#10		

1 PHASE CONNECTION

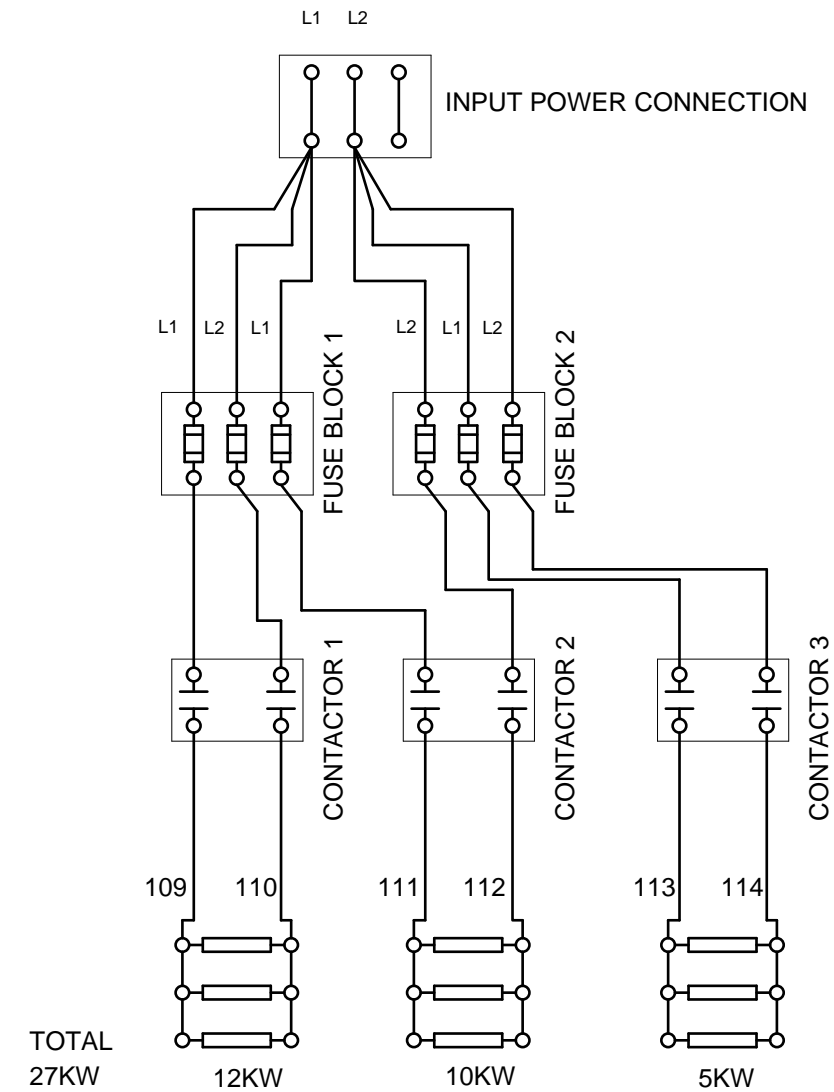

CANISTER 1 KW/CANISTER 27KW			
VOLTAGE 200-220V			
KW/CONTACTOR	12KW	10KW	5KW
CONTACTOR #	1	2	3
CONTACTOR RATING	75A	60A	60A
FUSE BLOCK #	1	2	3
FUSE RATING	70A	60A	30A
WIRE SIZE	#6	#6	#10
CANISTER 1 KW/CANISTER 27KW			
VOLTAGE 230-240V			
KW/CONTACTOR	12KW	10KW	5KW
CONTACTOR #	1	2	3
CONTACTOR RATING	60A	60A	60A
FUSE BLOCK #	1	2	3
FUSE RATING	60A	60A	30A
WIRE SIZE	#6	#6	#10

CUSTOMER TO SUPPLY RATED VOLTAGE/PHASE/Hz, AS SPECIFIED PER ORDER TO DISCONNECT SWITCH. ALL POWER SUPPLIED TO EACH CONNECTION POINT MUST COMPLY WITH ALL LOCAL ELECTRIC CODES.			
DR. BY	J.MCALLISTER	SCALE	NONE
DATE	03MAY04	SHEET	1 OF 1

REV.	DESCRIPTION	DATE	BY

REV.	DESCRIPTION	DATE	BY

<p>The Dishwashing Machine Specialists</p>	<p>CH-27E, 27KW BOOSTER FOR RACK CONVEYOR MACHINES</p>	
	<p>B 701888</p>	<p>REV.</p>

MODELS COVERED BY THIS DRAWING	
44DR	

NOTES:

- 7CR IS USED ONLY WITH A TABLE LIMIT SWITCH OR MRA TABLE. WHEN A TABLE LIMIT SWITCH IS NOT USED INSTALL JUMPER.
- WHEN TABLE LIMIT SWITCH OR MRA IS USED, CONNECT SWITCHES BETWEEN WIRES 6 AND 44 ON THE TERMINAL BLOCK IN THE PANEL.
- USED FOR MACHINE RUNNING SIGNAL.
- DRIVE MOTOR CONNECTED SINGLE PHASE FOR 200-240 VOLT MODELS.
- ON MODELS WITH SIDE LOADER OPTION DRIVE MOTOR CONTACTOR 1M IS CONNECTED TO WIRE #45 INSTEAD OF WIRE #11.
- ON MODELS WITH MULTIPLE ELECTRIC CONNECTIONS, MAKE HEATER POWER CONNECTIONS AT THE HEATER FUSE BLOCK.

1CR	RACK SWITCH RELAY
2CR	FINAL RINSE SWITCH RELAY
3CR	DOOR SAFETY SWITCH RELAY
5CR	WASH FILL RELAY
7CR	TABLE LIMIT SWITCH RELAY
11CR	DOUBLE RINSE FILL RELAY
12CR	DRAIN CONTROL RELAY
1M	DRIVE MOTOR CONTACTOR
1MOL	DRIVE MOTOR OVERLOAD
3M	WASH MOTOR CONTACTOR
3MOL	WASH MOTOR OVERLOAD
5M	BLOWER MOTOR CONTACTOR
5MOL	BLOWER MOTOR OVERLOAD
6M	DOUBLE RINSE MOTOR RELAY
AS	ARC SUPPRESSOR
BC-	BOOSTER CONTACTOR/STEAM VALVE
BDV	BLOWER DOOR SWITCH
BR	BOOSTER RELAY
CR	HOLD-IN RELAY
DC1	DOUBLE RINSE HEATER CONTACTOR
DV	DRAIN VALVE
DRFSW	DOUBLE RINSE TANK FLOAT SWITCH
FRSW	FINAL RINSE SWITCH
FU	FUSE/FUSE BLOCK
FV	FILL VALVE
HC-	HEAT CONTACTOR/STEAM VALVE
HLTS	HIGH LIMIT THERMOSTAT
JSW	JAM SWITCH
PCB	POWER SWITCH/CIRCUIT BREAKER
RSW	RACK SWITCH
RV	RINSE VALVE
T1	CONTROL TRANSFORMER
T2	DR MOTOR TRANSFORMER
TLS	TABLE LIMIT SWITCH
TR1	IDLE PUMP TIMER
TR2	DRAIN VALVE TIMER
TS	THERMOSTAT
W	WASH DOOR SWITCH
WFSW	WASH TANK FLOAT SWITCH

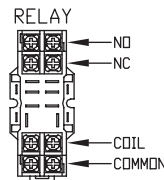
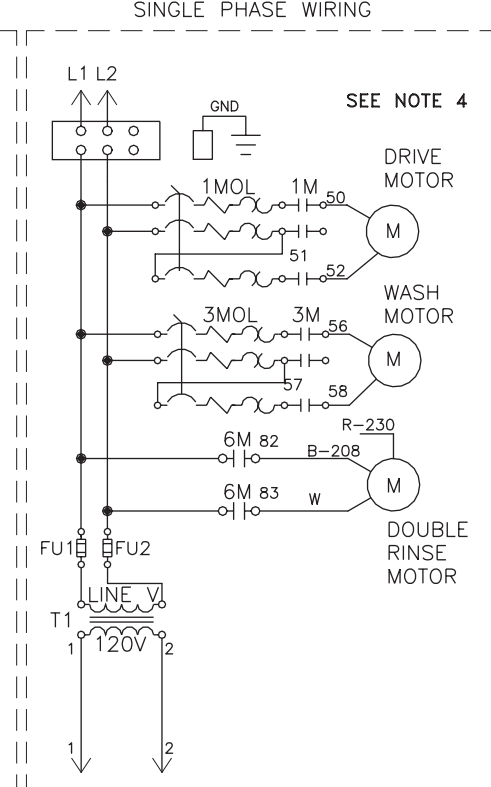
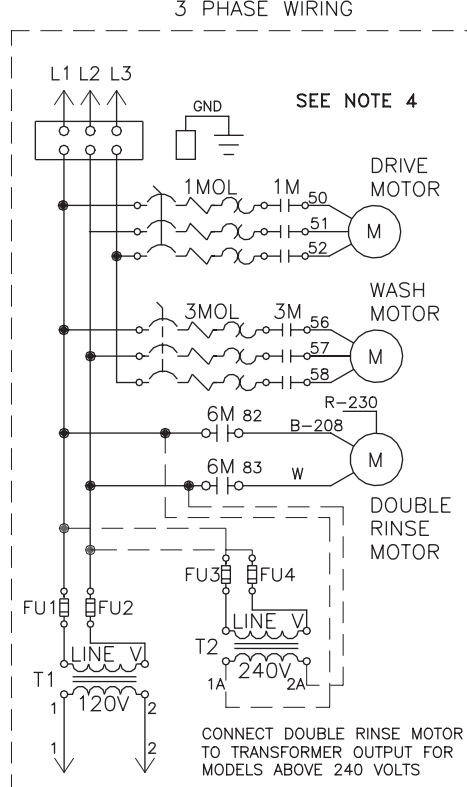
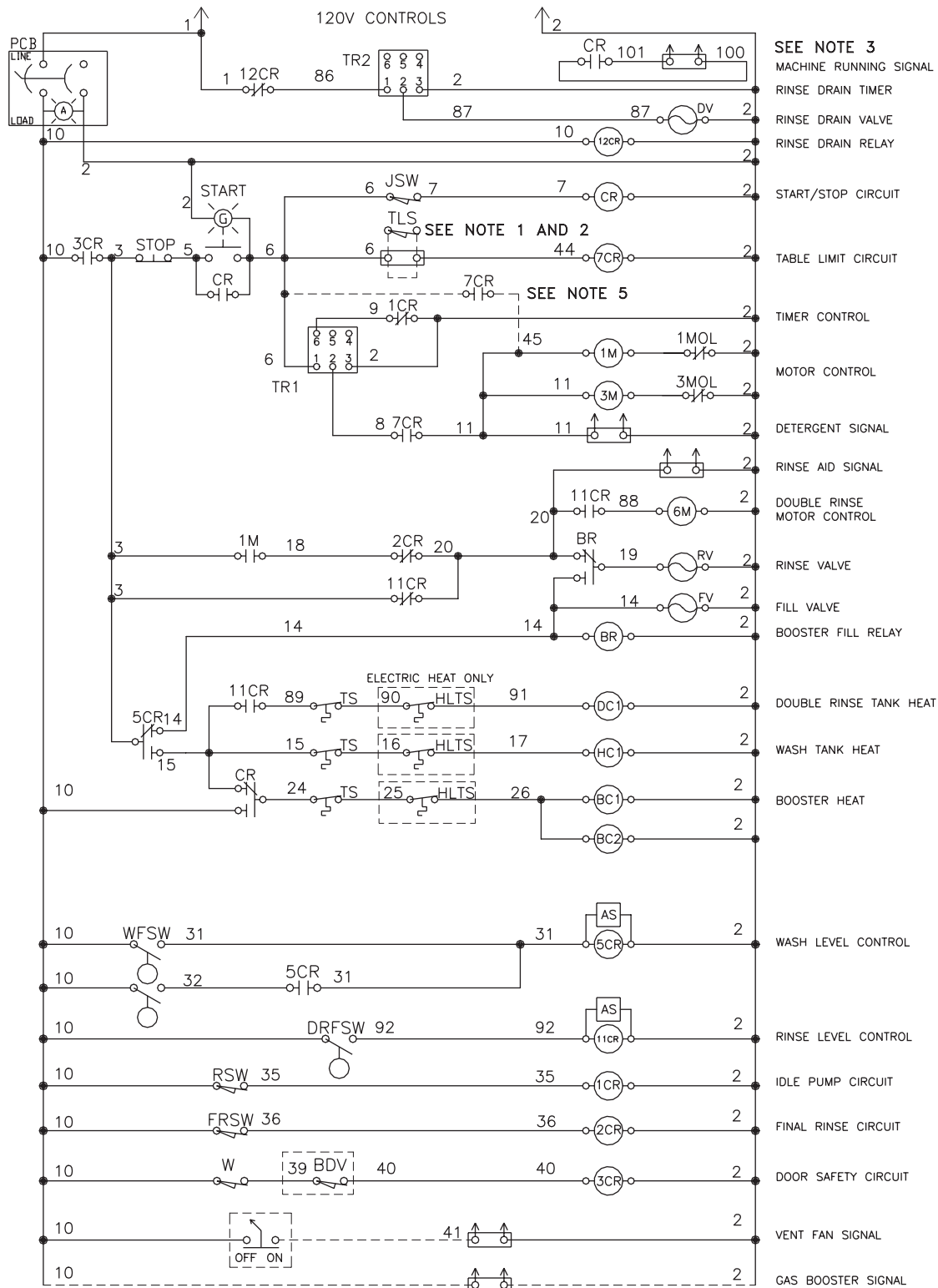
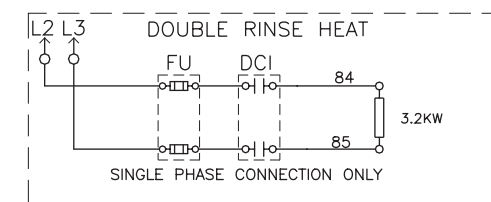
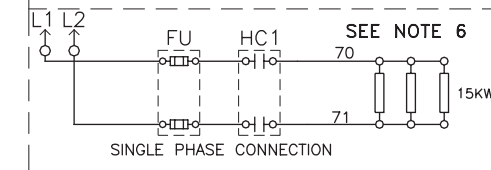
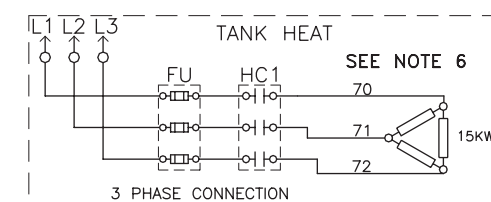
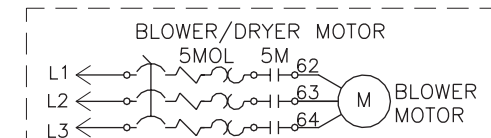

DIAGRAM STATE
POWER OFF
DOORS CLOSED
TANKS EMPTY



SEE DRAWING 114039 FOR BOOSTER HEATER WIRING



CUSTOMER TO SUPPLY RATED VOLTAGE/PHASE/Hz, AS SPECIFIED PER ORDER, TO DISCONNECT SWITCH. ALL POWER SUPPLIED TO EACH CONNECTION POINT MUST COMPLY WITH ALL LOCAL ELECTRIC CODES.

DR. BY	J.MCALLISTER	SCALE	NONE
DATE	07SEP04	SHEET	1 OF 1

REV.	DESCRIPTION	DATE	BY

Champion
The Dishwashing Machine Specialists

SINGLE TANK RACK CONVEYOR
DOUBLE RINSE STEAM/ELECTRIC HEAT
REV. **B 701912**

MODELS COVERED BY THIS DRAWING

66DRPW	70DRFFPW
80DRHDPW	

NOTES:

- 7CR IS USED ONLY WITH A TABLE LIMIT SWITCH OR MRA TABLE. WHEN A TABLE LIMIT SWITCH IS NOT USED INSTALL JUMPER.
- WHEN TABLE LIMIT SWITCH OR MRA IS USED, CONNECT SWITCHES BETWEEN WIRES 6 AND 44 ON THE TERMINAL BLOCK IN THE PANEL.
- USED FOR MACHINE RUNNING SIGNAL.
- DRIVE MOTOR CONNECTED SINGLE PHASE FOR 200-240 VOLT MODELS.
- ON MODELS WITH SIDE LOADER OPTION DRIVE MOTOR CONTACTOR 1M IS CONNECTED TO WIRE #45 INSTEAD OF WIRE #11.
- ON MODELS WITH MULTIPLE ELECTRIC CONNECTIONS, MAKE HEATER POWER CONNECTIONS AT THE HEATER FUSE BLOCK.

1CR	RACK SWITCH RELAY
2CR	FINAL RINSE SWITCH RELAY
3CR	DOOR SAFETY SWITCH RELAY
5CR	WASH FILL RELAY
6CR	PREWASH FILL RELAY
7CR	TABLE LIMIT SWITCH RELAY
11CR	DOUBLE RINSE FILL RELAY
12CR	DRAIN CONTROL RELAY
1M	DRIVE MOTOR CONTACTOR
1MOL	DRIVE MOTOR OVERLOAD
2M	PREWASH MOTOR CONTACTOR
2MOL	PREWASH MOTOR OVERLOAD
3M	WASH MOTOR CONTACTOR
3MOL	WASH MOTOR OVERLOAD
5M	BLOWER MOTOR CONTACTOR
5MOL	BLOWER MOTOR OVERLOAD
6M	DOUBLE RINSE MOTOR RELAY
AS	ARC SUPPRESSOR
BC-	BOOSTER CONTACTOR/STEAM VALVE
BDV	BLOWER DOOR SWITCH
BR	BOOSTER RELAY
CR	HOLD-IN RELAY
CWV	COLD WATER VALVE
DC1	DOUBLE RINSE HEATER CONTACTOR
DV	DRAIN VALVE
DRFSW	DOUBLE RINSE TANK FLOAT SWITCH
FRSW	FINAL RINSE SWITCH
FU	FUSE/FUSE BLOCK
FV	FILL VALVE
HC-	HEAT CONTACTOR/STEAM VALVE
HLTS	HIGH LIMIT THERMOSTAT
JSW	JAM SWITCH
PCB	POWER SWITCH/CIRCUIT BREAKER
PWFSW	PREWASH TANK FLOAT SWITCH
PWFV	PREWASH FILL VALVE
RSW	RACK SWITCH
RV	RINSE VALVE
T1	CONTROL TRANSFORMER
T2	DR MOTOR TRANSFORMER
TLS	TABLE LIMIT SWITCH
TR1	IDLE PUMP TIMER
TR2	DRAIN VALVE TIMER
TS	THERMOSTAT
W	WASH DOOR SWITCH
WFSW	WASH TANK FLOAT SWITCH

DIAGRAM STATE
 POWER OFF
 DOORS CLOSED
 TANKS EMPTY

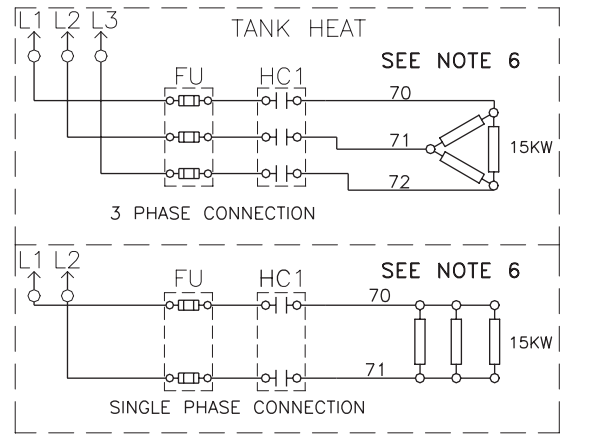
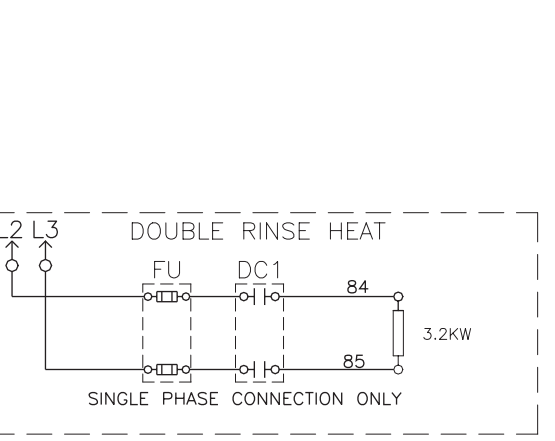
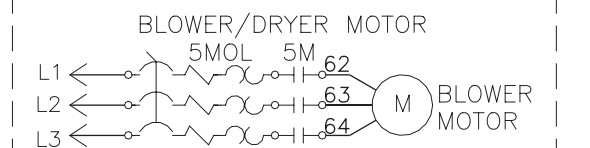
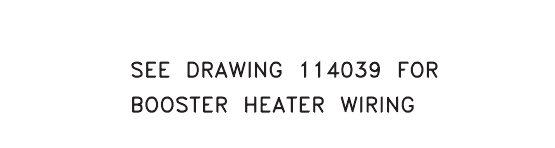
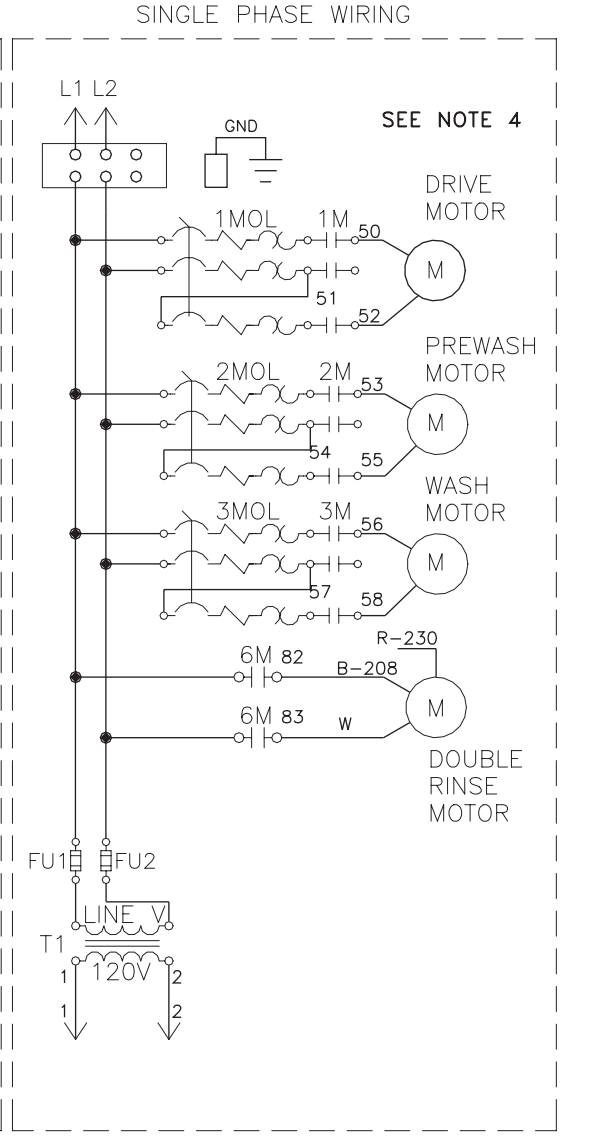
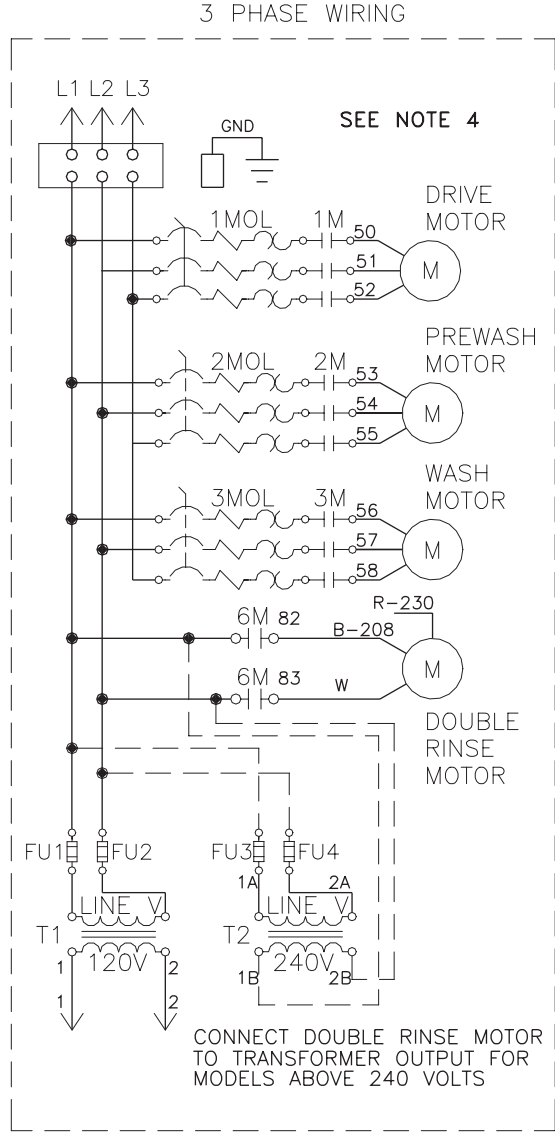
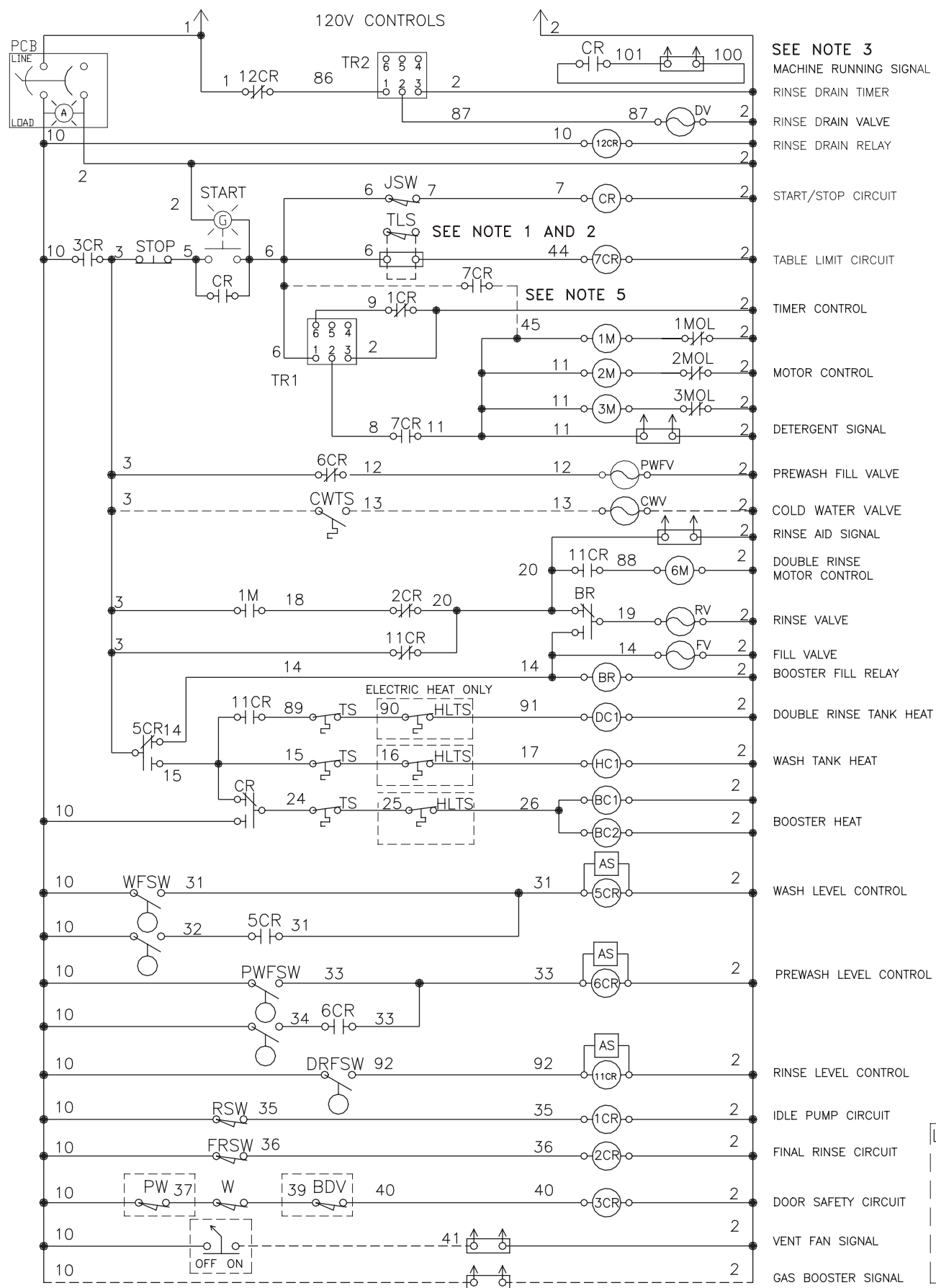

CUSTOMER TO SUPPLY RATED VOLTAGE/PHASE/Hz, AS SPECIFIED PER ORDER, TO DISCONNECT SWITCH. ALL POWER SUPPLIED TO EACH CONNECTION POINT MUST COMPLY WITH ALL LOCAL ELECTRIC CODES.

DR. BY J.MCALLISTER SCALE NONE
 DATE 23DEC04 SHEET 1 OF 1

REV.	DESCRIPTION	DATE	BY

REV.	DESCRIPTION	DATE	BY

Champion
 The Dishwashing Machine Specialists

SINGLE TANK RACK CONVEYOR WITH PREWASH
 DOUBLE RINSE STEAM/ELECTRIC HEAT

B 701913 REV.

MODELS COVERED BY THIS DRAWING	
86 PW	108 HDPW
90 FFPW	106 PW
100 HDPW	110 FFPW
94 PW	120 HDPW
98 FFPW	

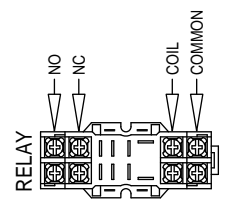
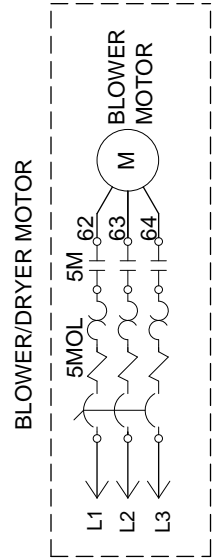
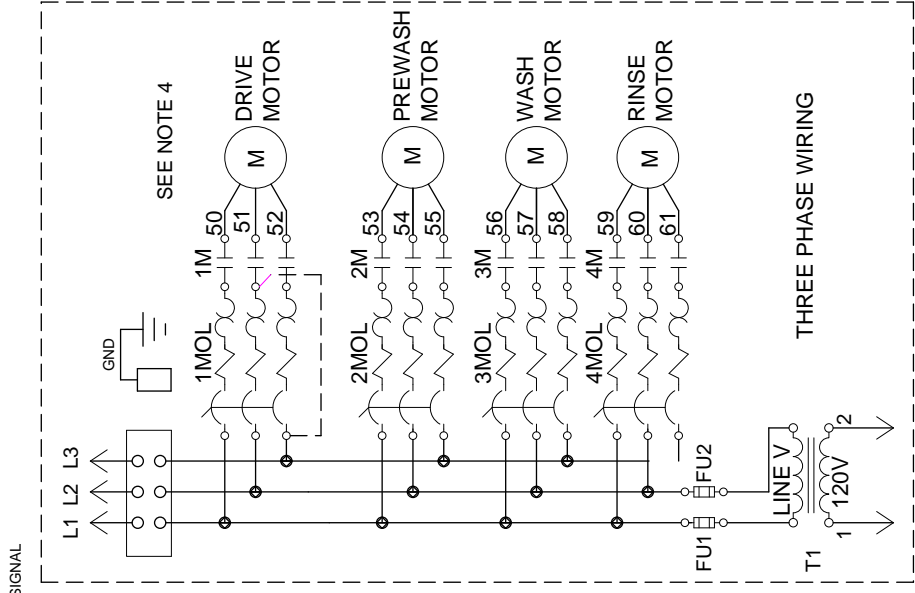
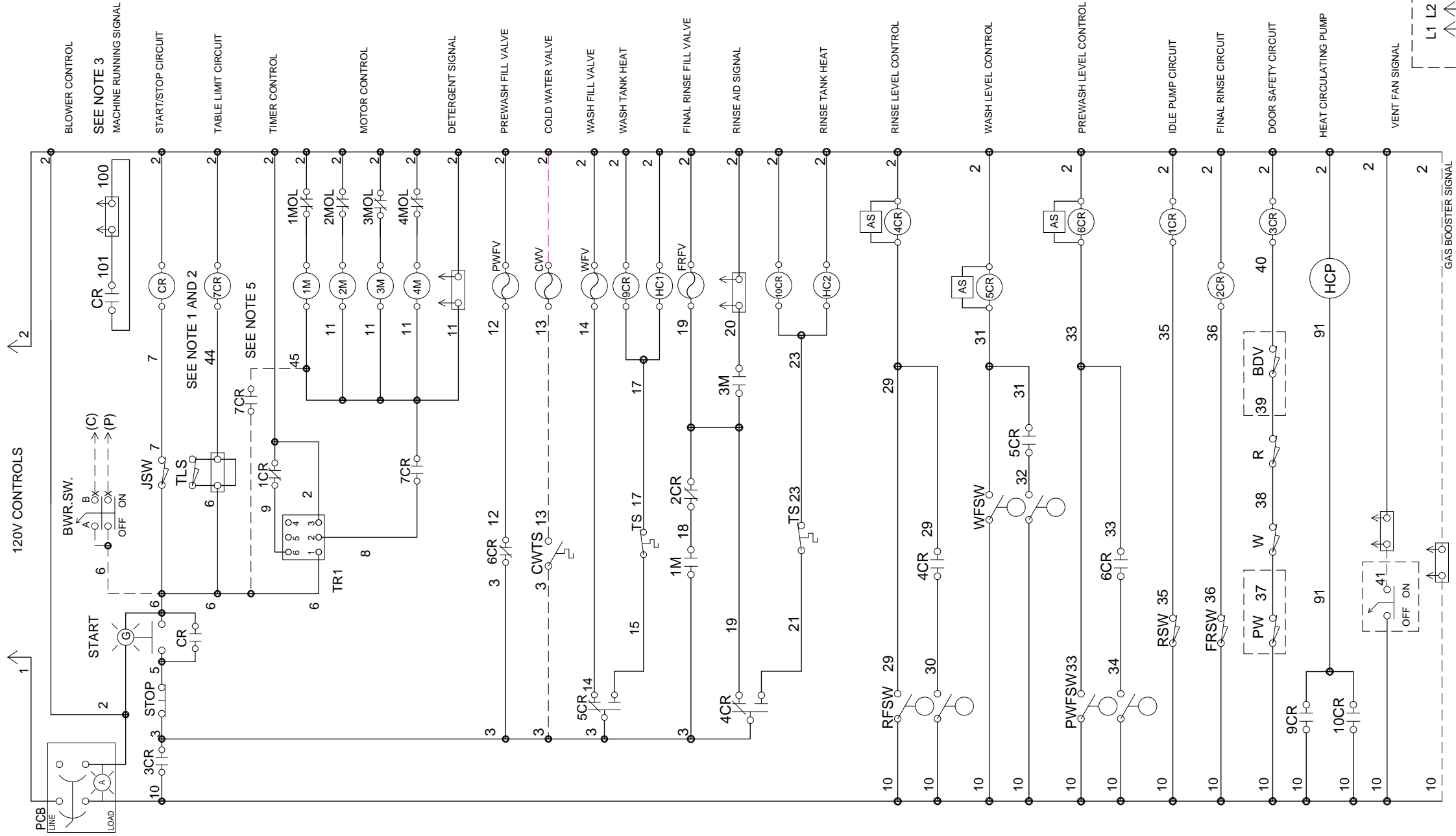

DIAGRAM STATE
POWER OFF
DOORS CLOSED
TANKS EMPTY

- NOTES:
- 7CR IS USED ONLY WITH A TABLE LIMIT SWITCH OR MRA TABLE.
 - WHEN A TABLE LIMIT SWITCH OR MRA IS NOT USED, INSTALL JUMPER.
 - WHEN TABLE LIMIT SWITCH OR MRA IS USED, CONNECT SWITCHES BETWEEN WIRES 6 AND 44 ON TERMINAL BLOCK IN PANEL.
 - USED FOR MACHINE RUNNING SIGNAL.
 - DRIVE MOTOR CONNECTED SINGLE PHASE FOR 200-240 VOLT MODELS.
 - ON MODELS WITH SIDE LOADER OPTION DRIVE MOTOR CONTACTOR 1M IS CONNECTED TO WIRE #45 INSTEAD OF WIRE #1.

1CR	RACK SWITCH RELAY
2CR	FINAL RINSE SWITCH RELAY
3CR	DOOR SAFETY SWITCH RELAY
4CR	RINSE FILL RELAY
5CR	WASH FILL RELAY
6CR	PREWASH FILL RELAY
7CR	TABLE LIMIT SWITCH RELAY
9CR	WASH HEAT RELAY
10CR	RINSE HEAT RELAY
1M	DRIVE MOTOR CONTACTOR
1MOL	DRIVE MOTOR OVERLOAD
2M	PREWASH MOTOR CONTACTOR
2MOL	PREWASH MOTOR OVERLOAD
3M	WASH MOTOR CONTACTOR
3MOL	WASH MOTOR OVERLOAD
4M	RINSE MOTOR CONTACTOR
4MOL	RINSE MOTOR OVERLOAD
5M	BLOWER MOTOR CONTACTOR
5MOL	BLOWER MOTOR OVERLOAD
AS	ARC SUPPRESSOR
BDV	BLOWER DOOR SWITCH
BWR.SW.	BLOWER SWITCH
CR	HOLD-IN RELAY
CWTS	COLD WATER THERMOSTAT
CWV	COLD WATER VALVE
FRSW	FINAL RINSE SWITCH
FU	FUSE/FUSE BLOCK
FRFV	FINAL RINSE FILL VALVE
FRSW	FINAL RINSE SWITCH
HC	HOT WATER VALVE
HCP	HEAT CIRCULATING PUMP
JSW	JAM SWITCH
PCB	POWER SWITCH/CIRCUIT BREAKER
PW	PREWASH DOOR SWITCH
PWFV	PREWASH FILL VALVE
PWFSW	PREWASH FLOAT SWITCH
R	RINSE DOOR SWITCH
RFSW	RINSE TANK FLOAT SWITCH
RSW	RACK SWITCH
T1	CONTROL TRANSFORMER
TLS	TABLE LIMIT SWITCH
TR1	IDLE PUMP TIMER
TS	THERMOSTAT
W	WASH DOOR SWITCH
WFSW	WASH TANK FLOAT SWITCH
WFV	WASH FILL VALVE

CUSTOMER TO SUPPLY RATED VOLTAGE/PHASE/HZ, AS SPECIFIED PER ORDER, TO DISCONNECT SWITCH. ALL POWER SUPPLIED TO EACH CONNECTION POINT MUST COMPLY WITH ALL LOCAL ELECTRIC CODES.			
DR.BY	J.MCALLISTER	SCALE	NONE
DATE	15SEP04	SHEET	1 OF 1

REV.	DESCRIPTION	DATE	BY
A	MOVED TABLE LIMIT SWITCH CIRCUIT	02DEC04	JAM

REV.	DESCRIPTION	DATE	BY

Champion
The Dishwashing Machine Specialists

TWO TANK RACK CONVEYOR WITH PREWASH, HOT WATER HEAT	
B	701918
REV.	A

CUSTOMER TO SUPPLY RATED VOLTAGE/PHASE/HZ, AS SPECIFIED PER ORDER, TO DISCONNECT SWITCH. ALL POWER SUPPLIED TO EACH CONNECTION POINT MUST COMPLY WITH ALL LOCAL ELECTRIC CODES.			
DR. BY	J.MCALLISTER	SCALE	NONE
DATE	05JAN05	SHEET	1 OF 1

REV.	DESCRIPTION	DATE	BY

REV.	DESCRIPTION	DATE	BY

Champion
The Dishwashing Machine Specialists

SINGLE TANK RACK CONVEYOR, DOUBLE RINSE WITH/WITHOUT PREWASH, HOT WATER HEAT
B 701937 REV.

MODELS COVERED BY THIS DRAWING	
44DR	70DRFFPW
66DRPW	80DRHDPW

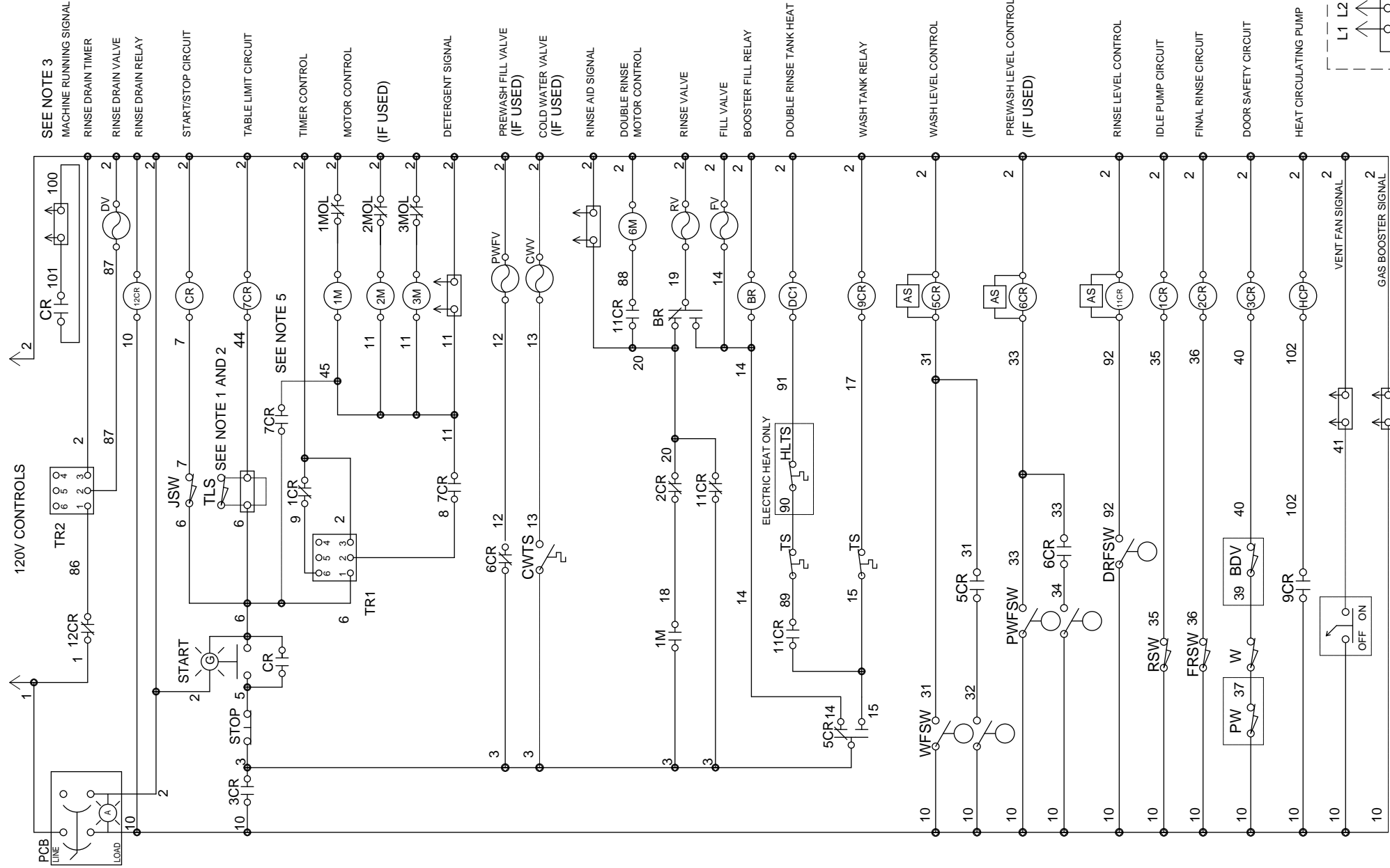

SEE NOTE 3

MACHINE RUNNING SIGNAL
RINSE DRAIN TIMER
RINSE DRAIN VALVE
RINSE DRAIN RELAY

START/STOP CIRCUIT

TABLE LIMIT CIRCUIT

TIMER CONTROL

MOTOR CONTROL

(IF USED)

DETERGENT SIGNAL

PREWASH FILL VALVE
(IF USED)

COLD WATER VALVE
(IF USED)

RINSE AID SIGNAL

DOUBLE RINSE
MOTOR CONTROL

RINSE VALVE

FILL VALVE

BOOSTER FILL RELAY

DOUBLE RINSE TANK HEAT

WASH TANK RELAY

WASH LEVEL CONTROL

PREWASH LEVEL CONTROL
(IF USED)

RINSE LEVEL CONTROL

IDLE PUMP CIRCUIT

FINAL RINSE CIRCUIT

DOOR SAFETY CIRCUIT

HEAT CIRCULATING PUMP

VENT FAN SIGNAL

GAS BOOSTER SIGNAL

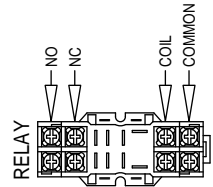
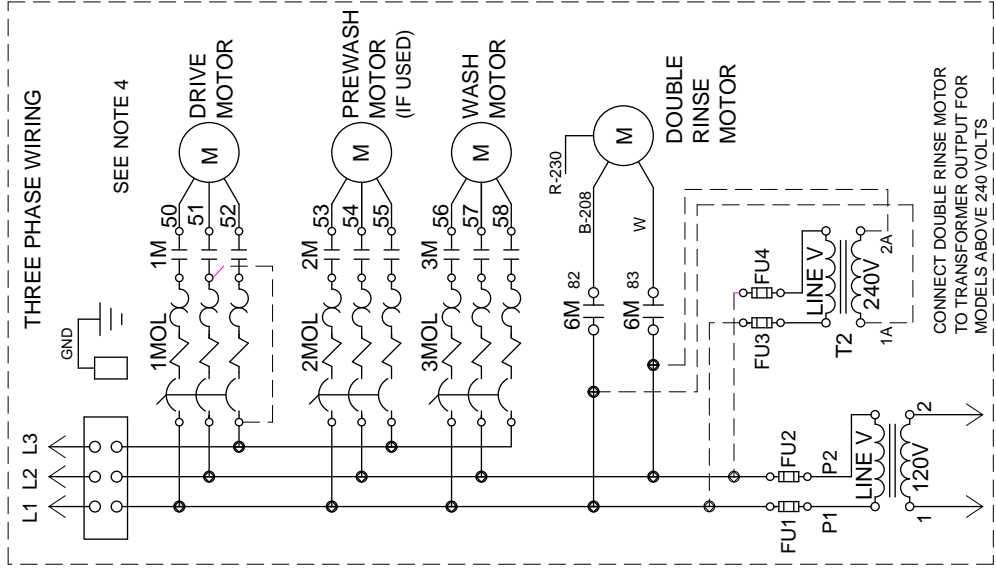

DIAGRAM STATE
POWER OFF
DOORS CLOSED
TANKS EMPTY

NOTES:

- 7CR IS USED ONLY WITH A TABLE LIMIT SWITCH OR MIRA TABLE. WHEN A TABLE LIMIT SWITCH IS NOT USED, INSTALL JUMPER.
- WHEN TABLE LIMIT SWITCH OR MIRA IS USED, CONNECT SWITCHES BETWEEN WIRES 10 AND 44 ON TERMINAL BLOCK IN PANEL.
- USED FOR MACHINE RUNNING SIGNAL.
- DRIVE MOTOR CONNECTED SINGLE PHASE FOR 200-240 VOLT MODELS.
- ON MODELS WITH SIDE LOADER OPTION, DRIVE MOTOR CONTACTOR 1M IS CONNECTED TO WIRE #45 INSTEAD OF WIRE #11.



SEE NOTE 4

CONNECT DOUBLE RINSE MOTOR TO TRANSFORMER OUTPUT FOR MODELS ABOVE 240 VOLTS

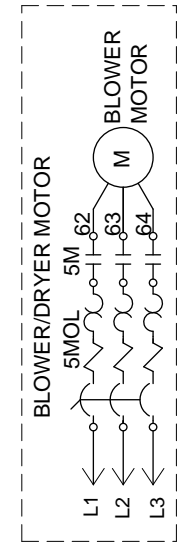
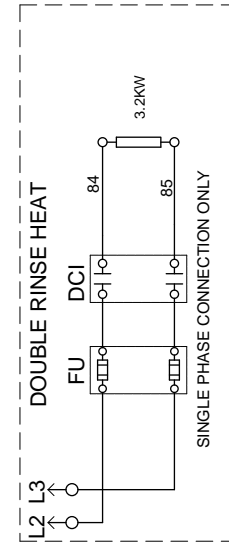

MODELS COVERED BY THIS DRAWING	
44	
44 LT	
54	

- NOTES:**
- 7CR IS USED ONLY WITH A TABLE LIMIT SWITCH OR MRA TABLE. WHEN A TABLE LIMIT SWITCH IS NOT USED INSTALL JUMPER.
 - WHEN TABLE LIMIT SWITCH OR MRA IS USED, CONNECT SWITCHES BETWEEN WIRES 6 AND 44 ON THE TERMINAL BLOCK IN THE PANEL.
 - USED FOR MACHINE RUNNING SIGNAL.
 - DRIVE MOTOR CONNECTED SINGLE PHASE FOR 200-240 VOLT MODELS.
 - ON MODELS WITH SIDE LOADER OPTION CONVEYOR DWELL SWITCH IS CONNECTED TO WIRE #45 INSTEAD OF WIRE #11.
 - ON MODELS WITH MULTIPLE ELECTRIC CONNECTIONS, MAKE HEATER POWER CONNECTIONS AT THE HEATER FUSE BLOCK.

1CR	RACK SWITCH RELAY
2CR	FINAL RINSE SWITCH RELAY
3CR	DOOR SAFETY SWITCH RELAY
5CR	WASH FILL RELAY
7CR	TABLE LIMIT SWITCH RELAY
1M	DRIVE MOTOR CONTACTOR
1MOL	DRIVE MOTOR OVERLOAD
3M	WASH MOTOR CONTACTOR
3MOL	WASH MOTOR OVERLOAD
5M	BLOWER MOTOR CONTACTOR
5MOL	BLOWER MOTOR OVERLOAD
AS	ARC SUPPRESSOR
BC-	BOOSTER CONTACTOR/STEAM VALVE
BDV	BLOWER DOOR SWITCH
BR	BOOSTER RELAY
BWR.SW.	BLOWER SWITCH
CR	HOLD-IN RELAY
CDS	CONVEYOR DWELL SWITCH
FRSW	FINAL RINSE SWITCH
FU	FUSE/FUSE BLOCK
FV	FILL VALVE
HC-	HEAT CONTACTOR/STEAM VALVE
HLTS	HIGH LIMIT THERMOSTAT
JSW	JAM SWITCH
PCB	POWER SWITCH/CIRCUIT BREAKER
RSW	RACK SWITCH
RV	RINSE VALVE
T1	CONTROL TRANSFORMER
TLS	TABLE LIMIT SWITCH
TR1	IDLE PUMP TIMER
TS	THERMOSTAT
W	WASH DOOR SWITCH
WFSW	WASH TANK FLOAT SWITCH

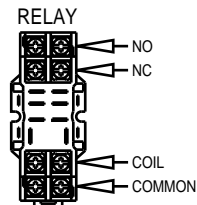
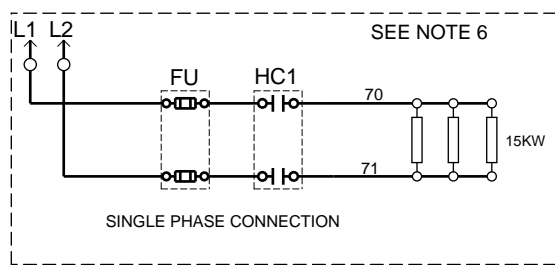
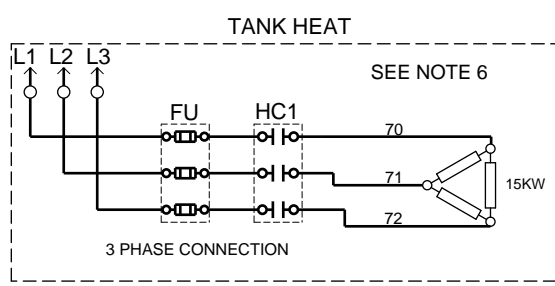
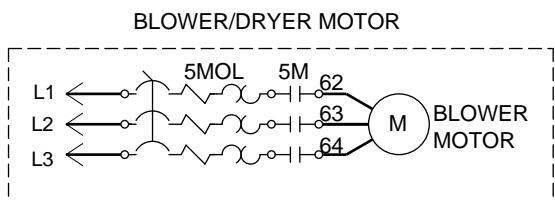
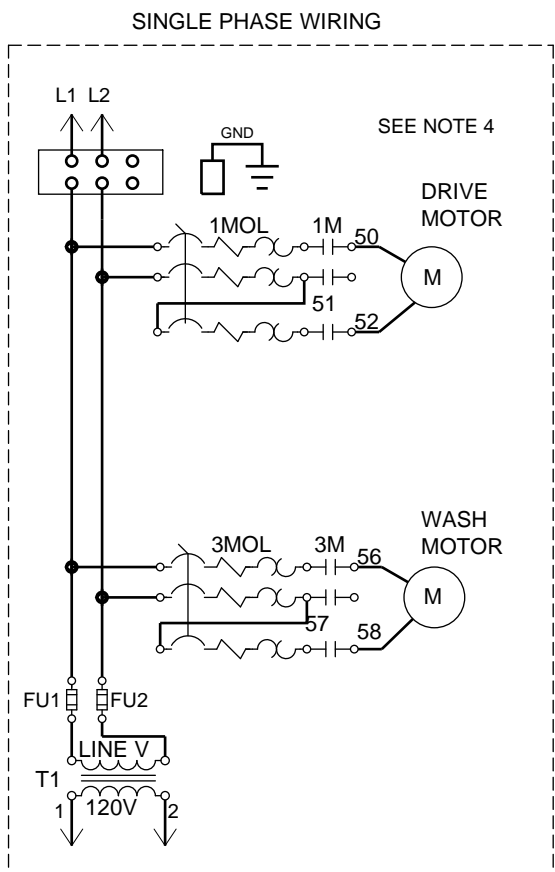
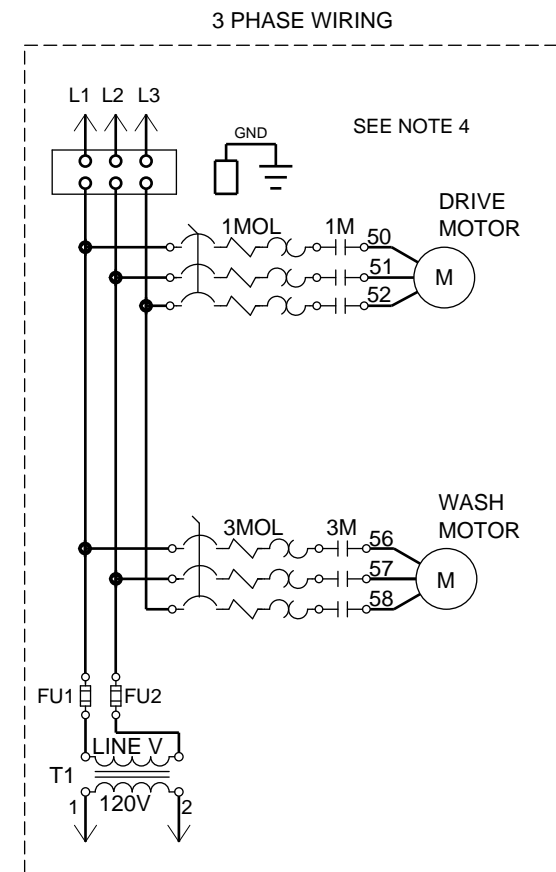
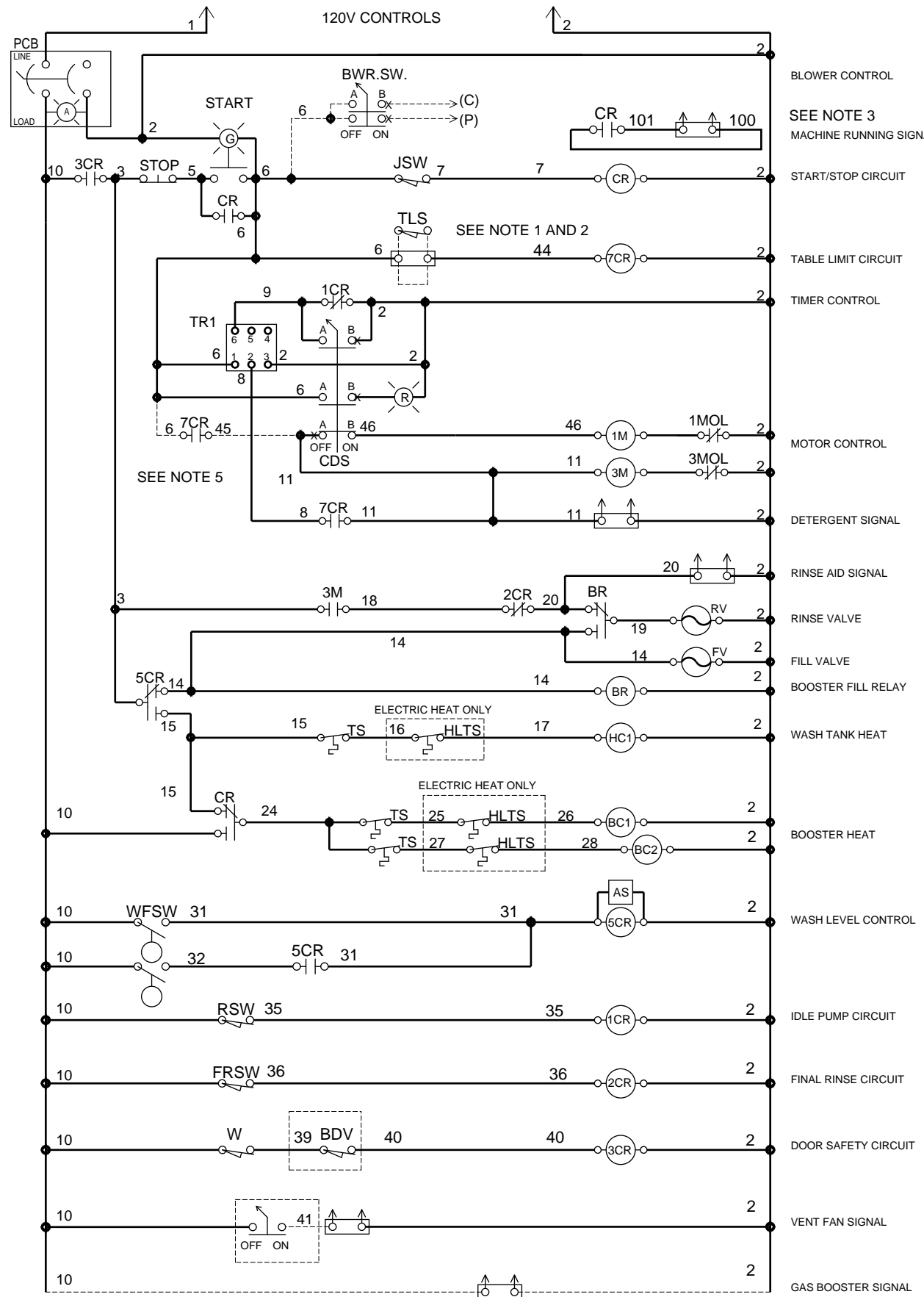

DIAGRAM STATE
POWER OFF
DOORS CLOSED
TANKS EMPTY



CUSTOMER TO SUPPLY RATED VOLTAGE/PHASE/Hz, AS SPECIFIED PER ORDER, TO DISCONNECT SWITCH. ALL POWER SUPPLIED TO EACH CONNECTION POINT MUST COMPLY WITH ALL LOCAL ELECTRIC CODES.

DR.BY	J.MCALLISTER	SCALE	NONE
DATE	04JAN05	SHEET	1 OF 1

REV.	DESCRIPTION	DATE	BY

REV.	DESCRIPTION	DATE	BY

Champion
The Dishwashing Machine Specialists

SINGLE TANK RACK CONVEYOR
STEAM/ELECTRIC HEAT CONVEYOR DWELL
B 701938 REV.