

Champion[®]

The Dishwashing Machine Specialists

Technical Manual

Undercounter Dishwasher

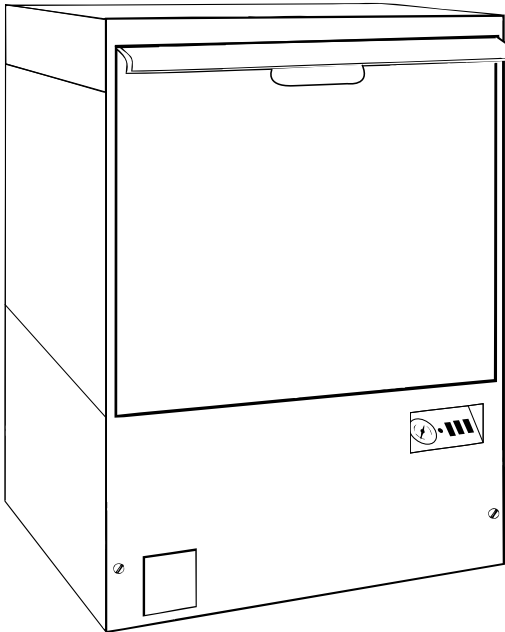

Model
TUV
U-BW
UTL

Machine Serial No.

August, 2001

Manual P/N **0508812** REV. H

P.O. Box 4149
Winston-Salem, North Carolina 27115-4149

Champion Industries, Inc.

336/661-1556

Fax: 336/661-1660

Complete the information below so it will be available for quick reference.

Model Number _____ Serial Number _____

Voltage and Phase _____

Champion Parts Distributor _____ Phone _____
(if applicable)

Champion Service Agency _____ Phone _____

Champion Industries Service: 1-800-858-4477 Champion Service Fax: 1-336-661-1660

NOTE: When calling to order parts, be sure to have the model number, serial number, voltage, and phase of your machine.

COPYRIGHT © 2001 by Champion Industries

Revision History

Revision Date	Revised Pages	Serial Number Effectivity	Comments
4/10/00	All	—	Added Models U-BW and UTL to manual and parts list.
11/16/00	38-39	—	Deleted P/N 112204 thermostat, replaced with P/N 109069 for all serial numbers.
1/17/01	17	—	Revised front panel number to 0308741.
8/22/01	21	—	Revised part numbers for hose clamps and hose.

CONTENTS

	Page
INTRODUCTION	1
WARRANTY	2
GENERAL	3
INSTALLATION	5
Unpacking	5
Electrical Connections.....	5
Plumbing Connections	6
Detergent	6
Rinse-Aid	6
Chemical Sanitizer	6
Completing Installation	7
OPERATION	8
Operation Summary	8
Operation Procedures	8
Extended Wash Cycle	9
MAINTENANCE.....	10
Cleaning Schedule.....	10
Deliming.....	11
Deliming Process.....	11
Maintenance Schedule.....	12
TROUBLESHOOTING	13
REPLACEMENT PARTS.....	15
ELECTRICAL DIAGRAMS	42
TIMER CHARTS and DIAGRAMS	46

LIST OF FIGURES

Figure 1—Track and Panel Assembly.....	16
Figure 2—Door and Switch Assembly.....	18
Figure 3—Tank Heat and Drain	20
Figure 4—Pump Assembly	22
Figure 5—Wash System Assembly.....	24
Figure 6—Water Inlet Piping	26
Figure 7—Fill System	28
Figure 8—Booster Assembly	30

Figure 9—Detergent Pump Assembly..... 32

Figure 10—Sanitizer/Rinse-Aid Pump Assembly..... 34

Figure 11—Drain Pump Assembly 36

Figure 12—Control Cabinet 38

Figure 13—Electrical Diagram, TUW (For machines beginning with S/N 6984)..... 42

Figure 14—Electrical Diagram, U-BW (For machines beginning with S/N 6984)..... 43

Figure 15—Electrical Diagram, UTL (For machines beginning with S/N 6984)..... 44

Figure 16—Electrical Diagram, TUW (50Hz)..... 45

Figure 17—Electrical Diagram, TUW (For machines built prior to S/N 6984) 46

Figure 18—Timer Chart and Diagram, TUW, U-BW 47

Figure 19—Timer Chart and Diagram, UTL 48

INTRODUCTION

Welcome to **Champion**.

Thank you for choosing **Champion** and for allowing us to take care of your dishwashing needs.

This manual covers several models. Model numbers are shown on the front cover.

Your machine has been completely assembled, inspected, and thoroughly tested at our factory to eliminate problems at installation before it was shipped to your installation site. This manual provides:

- Warranty information
- Installation and operation procedures
- Maintenance instructions
- Troubleshooting guide
- Replacement parts lists.

Complete and return your warranty registration card as soon as possible.

Champion constantly improves its products; therefore, specifications contained in this manual may have changed.

For your protection, factory authorized parts should always be used.

Replacement parts may be ordered directly from **Champion** or from your **Champion** authorized parts distributor or service agency.* When ordering parts, supply the model number, serial number, voltage and phase of your machine, the part number, part description, and quantity.

***Champion** can only ship parts to customers with accounts or by C.O.D.

LIMITED WARRANTY

Champion Industries/Moyer Diebel Limited, P.O. Box 4183, Winston-Salem, North Carolina 27115, and P. O. Box 301, 2674 North Service Road, Jordan Station, Ontario, Canada L0R 1S0 warrants machines, and parts, as set out below.

Warranty of Machines: Champion Industries/Moyer Diebel Limited warrants all new machines of its manufacture bearing the name "Champion" or "Moyer Diebel" and installed within the United States and Canada to be free from defects in material and workmanship for a period of one (1) year after the date of installation or fifteen (15) months after the date of shipment by Champion/Moyer Diebel, whichever occurs first. [See below for special provisions relating to Model Series DF and SW.] The warranty registration card must be returned to Champion/Moyer Diebel within ten (10) days after installation. If warranty card is not returned to Champion/Moyer Diebel within such period, the warranty will expire after one year from the date of shipment.

Champion/Moyer Diebel will not assume any responsibility for extra costs for installation in any area where there are jurisdictional problems with local trades or unions.

If a defect in workmanship or material is found to exist within the warranty period, Champion/Moyer Diebel, at its election, will either repair or replace the defective machine or accept return of the machine for full credit; provided, however, as to Model Series DF and SW, Champion/Moyer Diebel's obligation with respect to labor associated with any repairs shall end (a) 120 days after shipment, or (b) 90 days after installation, whichever occurs first. In the event that Champion/Moyer Diebel elects to repair, the labor and work to be performed in connection with the warranty shall be done during regular working hours by a Champion/Moyer Diebel authorized service technician. Defective parts become the property of Champion/Moyer Diebel. Use of replacement parts not authorized by Champion/Moyer Diebel will relieve Champion/Moyer Diebel of all further liability in connection with its warranty. In no event will Champion/Moyer Diebel's warranty obligation exceed Champion/Moyer Diebel's charge for the machine. The following are not covered by Champion/Moyer Diebel's warranty:

- a. Lighting of gas pilots or burners.
- b. Cleaning of gas lines.
- c. Replacement of fuses or resetting of overload breakers.
- d. Adjustment of thermostats.
- e. Adjustment of clutches.
- f. Opening or closing of utility supply valves or switching of electrical supply current.
- g. Adjustments to chemical dispensing equipment.
- h. Cleaning of valves, strainers, screens, nozzles, or spray pipes.
- i. Performance of regular maintenance and cleaning as outlined in operator's guide.
- j. Damages resulting from water conditions, accidents, alterations, improper use, abuse, tampering, improper installation, or failure to follow maintenance and operation procedures.

Examples of the defects not covered by warranty include, but are not limited to: (1) Damage to the exterior or interior finish as a result of the above, (2) Use with utility service other than that designated on the rating plate, (3) Improper connection to utility service, (4) Inadequate or excessive water pressure, (5) Corrosion from chemicals dispensed in excess of recommended concentrations, (6) Failure of electrical components due to connection of chemical dispensing equipment installed by others, (7) Leaks or damage resulting from such leaks caused by the installer, including those at machine table connections or by connection of chemical dispensing equipment installed by others, (8) Failure to comply with local building codes, (9) Damage caused by labor dispute.

Warranty of Parts: Champion/Moyer Diebel warrants all new machine parts produced or authorized by Champion/Moyer Diebel to be free from defects in material and workmanship for a period of 90 days from date of invoice. If any defect in material and workmanship is found to exist within the warranty period Champion/Moyer Diebel will replace the defective part without charge.

DISCLAIMER OF WARRANTIES AND LIMITATIONS OF LIABILITY. CHAMPION/MOYER DIEBEL'S WARRANTY IS ONLY TO THE EXTENT REFLECTED ABOVE. CHAMPION/MOYER DIEBEL MAKES NO OTHER WARRANTIES, EXPRESS OR IMPLIED, INCLUDING, BUT NOT LIMITED TO, ANY WARRANTY OF MERCHANTABILITY, OR FITNESS OF PURPOSE. CHAMPION/MOYER DIEBEL SHALL NOT BE LIABLE FOR INCIDENTAL OR CONSEQUENTIAL DAMAGES. THE REMEDIES SET OUT ABOVE ARE THE EXCLUSIVE REMEDIES FOR ANY DEFECTS FOUND TO EXIST IN CHAMPION/MOYER DIEBEL DISHWASHING MACHINES AND CHAMPION/MOYER DIEBEL PARTS, AND ALL OTHER REMEDIES ARE EXCLUDED, INCLUDING ANY LIABILITY FOR INCIDENTALS OR CONSEQUENTIAL DAMAGES.

Champion/Moyer Diebel does not authorize any other person, including persons who deal in Champion/Moyer Diebel dishwashing machines, to change this warranty or create any other obligation in connection with Champion/Moyer Diebel Dishwashing Machines.

GENERAL

This manual covers the **Champion** undercounter dishwashing machine. This machine is fully automatic and is equipped with a 1/2 H.P. pump motor. All models are available for mounting directly to the floor or on optional stands (see accessories listed on page 4).

Standard equipment includes:

- | | |
|------------------------------------|---|
| -Automatic tank fill | -Upper and lower wash/rinse arms |
| -Common utility connections | -Two dish racks (peg and flat) |
| -120 Volt control circuit | -Exclusive vent design for venting of condensation |
| -Convenient, easy to use controls | -Stainless steel heavy-gauge construction, including base |
| -Door latch activated start switch | |
| -Detergent pump | |

This series of dishwashers is available in the following models:

Model Numbers

TUW, U-BW, UTL

- The TUW model is a high temperature (82°C/180°F rinse) sanitizing model with booster.
- The U-BW model is a high temperature (82°C/180°F rinse) sanitizing model without booster.
- The UTL model is a low temperature (60°C/140°F rinse) sanitizing model for use with 5.25% or 8.4% sodium hypochlorite solution (chlorine bleach) as a sanitizing agent. The rinse aid pump is optional.

Options

- Kit 504 - Top and side panels (P/N 0708756)
- Kit 505 - Top panel only (P/N 0708744)
- Kit 506 - Left side panel only (P/N 0708745)
- Kit 507 - Right side panel only (P/N 0708746)
- Kit 508 - Rinse aid pump kit (P/N 0708754)
- Kit 510 - Extended reach pumped drain kit (TUW, U-BW, UTL) (P/N 0708766)
- Kit 511 - 30°C/70°F temperature rise booster (for 49°C/110°F supply water).

Accessories

- 17RS - 17" rack stand (raises working height and adds rack storage)
- 17T - 17" cabinet (raises working height and adds storage)
- CST - Combination sink/table (scrapping and sorting station)
- 0501653 - Dish Rack (Peg Rack)
- 0501654 - Silverware Rack (Flat Bottom Rack)

Electrical Power Requirements

Model	Voltage	Booster Rise	Machine Full Load Amp	Power Requirement (125% Service Factor)
UTL	115/60/1	N/A	12	15
U-BW	115/60/1	N/A	12	15
TUW	208/60/1	40	36	44
TUW	240/60/1	40	40	49
TUW	208/60/1	70	48	59
TUW	240/60/1	70	55	68

NOTE:

208-240V/60Hz/1PH electrical supply service must be a 3-wire plus ground for connection as shown.

00023

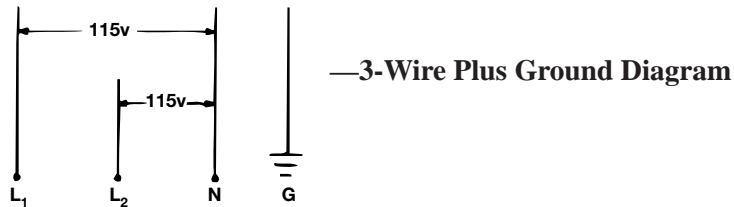

INSTALLATION

Unpacking

**WARNING:**

Care should be taken when lifting the machine to prevent damage.

1. Immediately after unpacking your machine, inspect for any shipping damage. If damage is found, save the packing material and contact the carrier immediately.
2. Remove the dishwasher from the skid. Adjust the feet if required, then move the machine to its permanent location.
3. Level the machine (if required) by placing a level on the top of the machine and adjusting the feet. Level the machine front-to-back and side-to-side.

**CAUTION:**

After locating your machine, it must meet local health codes. An example may be to seal your machine to the floor using a good grade of silicone sealant.

Electrical Connections

**WARNING:**

Electrical and grounding connections must comply with the National Electrical Code and/or Local Electrical Codes.

**WARNING:**

When working on the dishwasher, disconnect the electric service and tag it to indicate work is being done on that circuit.

1. The electrician should compare the electrical specifications on the machine electrical junction box (located behind the front panel) to the electrical power supply before connecting the machine to the incoming service at a fused disconnect switch.

**NOTE:**

The 208-240V/60Hz/1PH electrical supply service for this machine must be a 3-wire plus ground service.

2. On the 208V-240V models, a knock-out is provided at the rear of the junction box (located behind the front panel) for electrical service connections. A fused disconnect switch or circuit breaker (supplied by user) is required to protect each power supply circuit.
3. On 115V models, your machine is already equipped with a 4-foot power cord and plug suitable for 115V-15A service.

Plumbing Connections



CAUTION:

Plumbing connections must comply with local sanitary and plumbing codes.

Water Connections

1. Connect the hot water supply (60°C/ 140°F Min) to the 1/2" I.D. fill hose. The fill solenoid valve is equipped with a flow control that will accept water pressures from 172 kPa/25 psi to 665 kPa/95 psi.
2. Install a manual shut-off valve in the water supply line to accommodate servicing the machine. The shut-off valve should be the same size or larger than the supply line.
3. The fill solenoid valve is equipped with a built-in strainer to protect from particles in the water supply.

Drain Connections

1. All Models are supplied with a flexible 5/8" I.D. drain hose, which must be connected to a 1-1/2" drain using a wye (Y) fitting.

Detergent

1. Use a qualified detergent/chemical supplier for your detergent, rinse aid, and chemical sanitizer needs.
2. Your machine is supplied with a detergent dispensing pump that is internally wired and ready for use. Using a liquid detergent, insert the labeled *Detergent* pickup tube into the detergent container. The pickup tube has a strainer on the end to prevent crystallized chemical from clogging the supply lines.
3. The cycle timer located in the main control cabinet is equipped with adjustable cams for the chemical dispensing pump(s). The cams control the length of time that the pumps operate. A qualified person may adjust the cam settings if necessary. Refer to the timer chart diagram(s) at the end of the manual for timer cam locations and factory time settings.



NOTE:

A nonchlorinated detergent is recommended for your dishwasher.

Rinse Aid

1. An optional rinse aid pump may be supplied for all models. Using a liquid rinse aid, insert the labeled *Rinse Aid* pickup tube into the rinse aid container.

Chemical Sanitizer

1. Model UTL is supplied with an internally wired chemical sanitizer dispensing pump. Using a 5.25% or 8.4% sodium hypochlorite solution, insert the labeled *Chemical Sanitizer* pickup tube into the chemical sanitizer container.
2. Contact your chemical supplier for adjustment of the chemical sanitizer.

Completing Installation

1. Remove any foreign material from inside the machine.
2. Center the scrap screen over the sump opening.
3. Prime the booster using the following procedure (if applicable).

**CAUTION:**

To prime the booster, the following procedure must be followed AFTER the electrical and plumbing connections have been made.

- a. Close the front door.
- b. Remove the front panel.
- c. Locate the Installation and Service toggle switch on the extreme left side of the control box.
- d. Press the toggle switch down to the Booster Fill position and hold it approximately 1 minute (or until water can be heard entering the machine).
- e. Release the toggle switch to stop the water flow.
- f. You have completed the booster priming process.

**NOTE:**

Push the Installation and Service toggle switch to the UP position. Electrical power is now supplied to the machine.

**WARNING:**

Failure to prime the booster may cause damage to the booster elements and other electrical components and will void the warranty.

4. After plumbing and electrical connections are completed, check the machine for water leaks by depressing the **ON/FILL** switch on the front panel, then close and latch the door. This allows the tank to fill and to complete the rinse cycle. Check for leaks.
5. Open the door and check the water level. The water level should barely cover the scrap screen.
6. Depress the **OFF/DRAIN** switch and close and latch the door to drain the tank. This allows the machine to complete the 100-second wash and drain cycle. Check the drain plumbing for leaks.
7. Replace the front panel. Installation is now complete.

OPERATION

Operation Summary

The following is a summary of your Undercounter Dishwashing Machine operating cycle:

1. The cycle begins when you depress the front edge of the door latch toward the door.
2. The green cycle lamp lights and the pump starts.
3. The pump runs during the wash cycle for approximately 80 seconds.
4. The pump stops, and the drain is opened.
5. After a 2-3 second pause, the pump drain cycle begins and continues for approximately 30 seconds.
6. After a 2-3 second pause, the fill valve opens, and the pump starts for the rinse cycle.
7. Within approximately 25 seconds, the rinse cycle is complete. The pump stops, the green cycle lamp turns off, and the cycle is complete.
8. Open the door and remove the rack of clean ware. The door must remain open for 5 seconds to allow the timer to reset before starting another cycle.

Operation Procedures

The operation of your dishwasher will be more efficient when these procedures are followed:

1. Check that the spray arms and scrap screen are in place.
2. Close the door and depress the front edge of the door latch toward the door. Push the **ON/FILL** switch to the **ON** position. The tank will begin filling with water. This procedure is followed only when the tank is empty.
3. When the tank is full, check the wash tank temperature gauge. Minimum wash temperatures are:
 - TUW, U-BW – **150°F/66°C**.
 - UTL – **140°F/60°C**.
4. Scrap and preflush all items to be washed, and load the items into the rack. **DO NOT OVERLOAD** the rack. Wash only one layer of silverware in a rack.
5. Open the door and insert the rack into the machine.
6. Shut the door, and depress the door latch. This will start the wash cycle. The green cycle lamp located on the front control panel will light. This lamp will remain on until the entire wash and rinse cycle is completed.

⇒ NOTE:

The machine may be stopped at any time by opening the door. When restarted, the cycle does not start over. It will continue from the point at which it was interrupted.

7. Check the rinse temperature during the final rinse (120 seconds into cycle). The rinse temperature must be 180°F/82°C minimum for models TUW, U-BW, and 140°F/60°C for model UTL.
8. The pump will automatically stop and the green cycle light will turn off indicating the cycle is completed.
9. Open the door and remove the rack.
10. Repeat steps 4-9 for additional cycles. Machine operation is automatic.
11. CLEAN the scrap screen after every meal period. During heavy usage, the scrap screen should be cleaned more frequently.

**CAUTION:**

Poor machine performance and/or damage to the machine can occur if the scrap screen becomes clogged with soil or waste particles.

12. After completing usage for the day, water in the tank should be drained by depressing the OFF/DRAIN switch and closing and latching the door. This initiates a 100-second wash and drain cycle that drains the tank.

**CAUTION:**

DO NOT LEAVE WATER IN THE TANK OVERNIGHT. Water left in the tank overnight will allow harmful chemicals to deteriorate the tank.

Extended Wash Cycle

On models TUW, U-BW, but not on model UTL, an extended wash cycle is available for pots, pans and heavily soiled items.

To use the Extended Wash Cycle:

1. Insert the loaded rack into the machine. Close the door and depress the latch. Wait 10 seconds for the detergent to be dispensed automatically.
2. Flip the **Extended Wash/Delime Switch** to the **UP** position. The green cycle light will go out, indicating that the machine is in a **continuous** wash mode.
3. When your desired wash time has passed, flip the **Extended Wash/Delime Switch** to the **DOWN** position. The green cycle light will come on, indicating a return to the normal wash mode. The machine will now complete the remaining portion of the automatic cycle.

MAINTENANCE

The efficiency and life of your machine is increased by regularly scheduled preventive maintenance. A well maintained machine gives better results and service. An investment of a few minutes of daily maintenance will be worthwhile.

The best maintenance you can provide is to keep your machine clean. Components that are not regularly cleaned and flushed will clog and become inoperative.

Intervals shown in the following schedules represent an average length of time between necessary maintenance. Maintenance intervals should be shortened whenever your machine is faced with abnormal working conditions, hard water, or multiple shift operations.

Cleaning Schedule

- **Daily-Every 8 Hours**

1. Depress the **OFF/DRAIN** switch to **OFF** and close and latch the door to drain the tank.
2. Open the door and remove both the upper and lower spray arms by unscrewing the knurled fastener holding each spray arm.
3. Remove the scrap screen carefully to keep soil or waste particles from falling into the sump.
4. Clean inside the tank with clean water. Backflush the scrap screen until it is clean. Do not strike the screen against solid objects.
5. Clean the wash arms to remove any debris from spray openings. Do not strike the spray arms against solid objects.
6. Reinstall the scrap screen and spray arms.
7. Leave the door open overnight to allow drying.
8. Report any unusual conditions to your supervisor.

- **Meal Periods**

1. Clean the scrap screen after every meal period and more frequently during heavy usage. Do not allow the scrap screen to become clogged with soil or waste particles.

Deliming

Your dishwasher should be delimed regularly as required. This will depend on the mineral content of your water.

Inspect your machine interior for lime deposits. If deliming is required, a deliming agent should be used for best results.

If you have the chemical sanitizing model (UTL), carefully follow the following procedure before deliming:



DANGER:

Deliming solution or other acids must not come in contact with household bleach (sodium hypochlorite) or any chemicals containing chlorine, iodine, bromine, or fluorine. Mixing will cause hazardous gases to form. Skin contact with deliming solutions can cause severe irritation and possible chemical burns. Consult your chemical supplier for specific safety precautions.

1. Remove the sanitizer tube from the container. Place the tube into a container of hot water.
2. Depress and hold the **SANITIZER** prime switch (located on the front panel) until clear water enters the tank through the fill air gap.
3. Close the door and depress the door latch. Complete two operating cycles to purge the machine of all sanitizer.

Deliming Process

Complete the following procedure to delime your machine:

1. Add the delime chemical to wash the tank (per chemical supplier specifications).
2. Close and latch the door.
3. On models TUW and U-BW, depress the **EXTENDED WASH/DELIME** switch on the front panel as soon as the cycle starts. On model UTL, proceed to step 5 of this procedure.

NOTE:

*The **EXTENDED wash/delime** switch will operate only during the wash cycle. When this switch is in the **ON** position, the machine stays in the wash cycle until the switch is **OFF**. After switching to **OFF**, the machine will finish the cycle.*

4. After 2-1/2 to 3 minutes (or as long as required), turn off the **EXTENDED WASH/DELIME** switch. The machine will finish a complete cycle.
5. Complete two cycles with the machine empty to purge the machine of all delime chemicals.
6. Deliming is complete.

Maintenance Schedule

- **As Required**
 1. Check the temperature gauge reading.
 2. Check the chemical supplies and refill as necessary.
- **Weekly**
 1. Inspect all water lines for leaks and tighten them at joints if required.
 2. Clean all detergent residue from the exterior of the machine.
 3. Check the drain for leaks.
 4. Clean accumulated scale from the heating element.
 5. Remove and closely inspect each spray arm for blockage.
 6. Check for damage to the scrap screen. Ineffective screening can cause wash system failures.
 7. Clean the detergent, sanitizer, and rinse aid supply tubes. Complete the following procedure:
 - a. Remove the detergent, sanitizer, and rinse aid pick-up tube(s) from the container(s). Place the tube(s) into a container of hot water.
 - b. Depress and hold the **DET** prime switch (located on the front panel) until clear water enters the tank through the fill air gap (located on the right side of the tank).
 - c. If your machine is equipped with a sanitizer and/or rinse aid pump, follow the same procedure by pressing the **SANITIZER** and/or the **RINSE AID** prime switch until clear water enters the tank through the fill air gap.
 - d. When completed, remove the pickup tubes from the hot water and reinsert them into the correct chemical containers. Repeat the priming procedures to ensure that chemicals have filled the tubes for the next operating period.
 - e. Run a complete cycle to flush chemicals from the tank.

TROUBLESHOOTING

Before determining any specific cause of a breakdown or abnormal operation of your dishwasher, check that:

1. Turn all switches ON, except for the extended wash switch.
2. Wash arms are clean.
3. Scrap screen is properly positioned and clean.
4. Thermostat(s) are at their correct setting.
5. Sanitizer, detergent, and rinse additive dispensers are adequately filled.
6. All plumbing valves are open.

If a problem still exists, use the following table for troubleshooting.

CONDITION	CAUSE	SOLUTION
Machine will not start	Door not closed and latched Main switch off, or unit unplugged	Make sure door is fully latched Check disconnect or plug into outlet Make sure the extended wash switch is in the OFF position.
Low or no water	Main water supply is turned off	Turn on house water supply
Chemical not feeding	No chemical in container..... Feed tubes to/from chemical pump clogged Screen on feed tube clogged..... Tubing kinked or split	Replace or fill container Clear obstruction and flush with hot water Clean and replace Straighten or replace tubing
Water temperature is low when in use	Incoming water temperature..... at machine too low Hi limit tripped	Raise temperature to 60°C/140°F for all machines Reset hi limit
Insufficient pumped spray pressure	Clogged spray arm Scrap screen full	Clean Must be kept clean and in place
Low final rinse temperature	Low incoming water..... temperature Hi limit tripped	Check the booster - be sure the thermostat is set to maintain 66°C/180°F temperature (UTL is 60°C/140°F) (Check all valves to be sure they are clean and operating) Reset hi limit
Poor washing results	Water level low in wash tank..... should be at or 1/2" (13mm) above screen Detergent dispenser not operating properly Insufficient detergents	Check fill valve and water pressure Contact service agent Check and fill Contact detergent supplier Contact detergent supplier
	Detergent setting too low Wash water temperature too low..... Wash arm clogged Improperly scraped dishes..... Ware being improperly..... placed in rack Improperly cleaned equipment Electric element has soil/lime buildup	See above booster temperatures Clean wash arm Check scraping procedures Use proper racks - do not overload racks Unclog wash arms to maintain proper pressure and flow conditions Clean and delime

TROUBLESHOOTING (con't)

CONDITION	CAUSE	SOLUTION
No water in wash well	Opening door prior to cycle completion	Close door. Wait for green cycle light to go out before opening door.
No water in wash tank after activating the ON/FILL switch	Door not latched	Latch door. Wait for wash tank to fill.

REPLACEMENT PARTS

00001

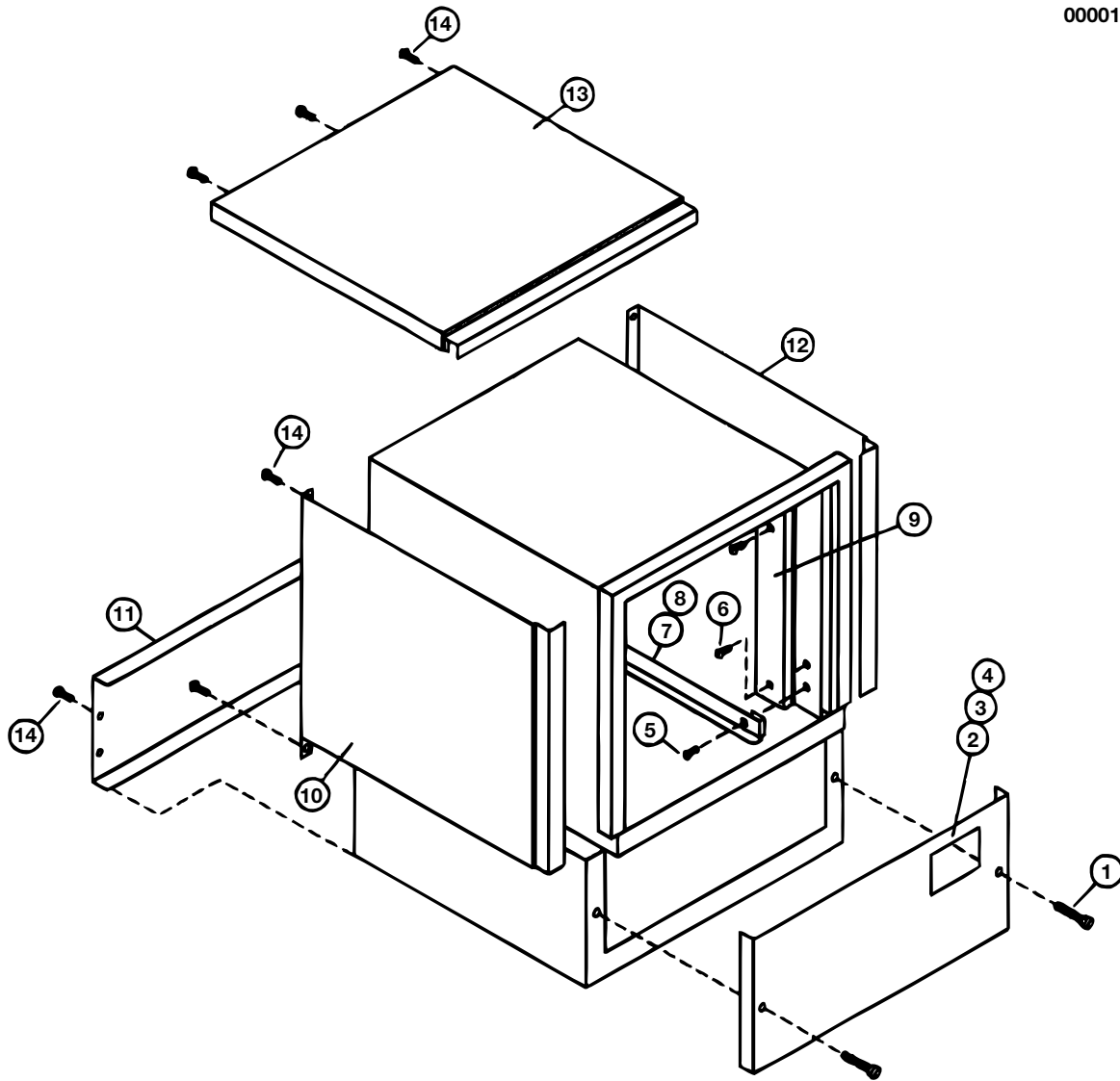

Figure 1 — Track and Panel Assembly

TRACK/PANEL ASSEMBLY

Fig. 1 Item No.	Part No.	Description	Qty
1	0508751	Screw, 10-32 x 1-1/2" Lg. Truss Head	2
2	0308741	Front Panel (TUW, U-BW, UTL) (S/N 6795 and above).....	1
3	0308741	Front Panel (UTL).....	1
4	—	No Longer Available	
5	0501413	Screw, 10-32 x 3/8" Lg. Round Head.....	2
6	0501415	Screw, 10-32 x 5/8" Lg. Round Head.....	4
7	0308632	Track, RH	1
8	0308631	Track, LH	1
9	0708647	Cover, Vent	2
10	0308736	Panel, LH Side (UTL, TUW, U-BW).....	1
11	0308734	Panel, Rear (UTL, TUW, U-BW).....	1
12	0308737	Panel, RH Side (UTL, TUW, U-BW).....	1
13	0308735	Panel, Top UTL, TUW, U-BW)	1
14	0501412	Screw, 10-32 x 3/8" Lg. Truss Head (UTL)	10

00020

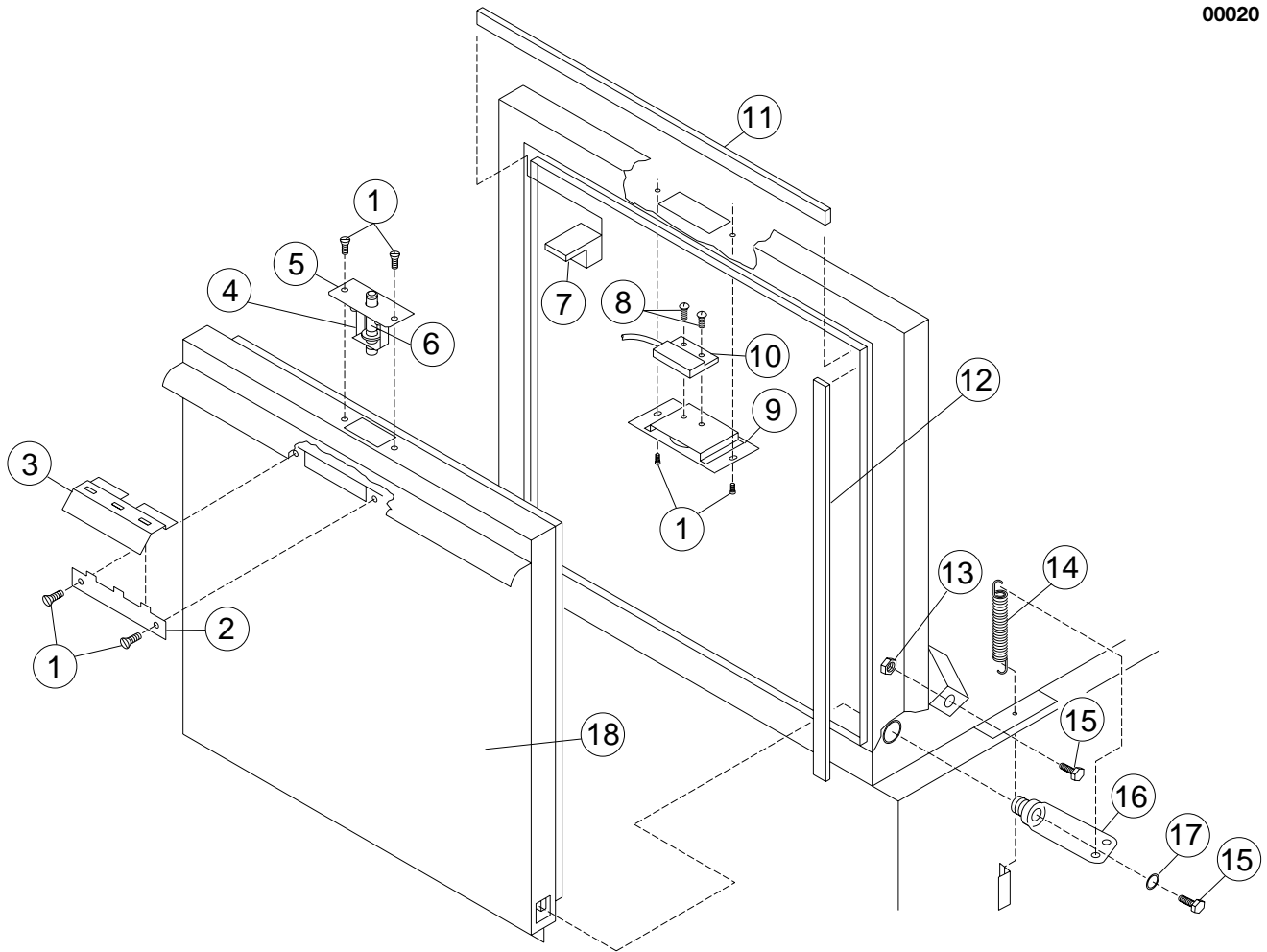

Figure 2 — Door Switch Assembly

DOOR & SWITCH ASSEMBLY
(For Machines Beginning with S/N 6984 and Above)

Fig. 2 Item No.	Part No.	Description	Qty
1	0501412	Screw, 10-32 x 3/8" Truss Head	6
2	0308596	Plate, Door Latch.....	1
3	0308597	Handle, Door Latch	1
4	0508721	Retaining Ring, Plunger	1
5	0709462	Assembly, Door Catch (Includes items 4, 6)	1
6	0509436	Plunger, Door Catch	1
7	0508545	Gasket, Steam	2
8	104883	Screw, Round Head (6-32 x 3/8").....	2
9	0709431	Plate, Door Switch.....	1
10	111090	Switch, Door Magnetic Reed	1
11	0508544	Gasket, Upper Door	1
12	0508543	Gasket, Side Door.....	2
13	0501539	Nut, Plain 1/4-20	2
14	0503715	Spring, Door Hinge	2
15	0501421	Bolt, 1/4-20 x 1-1/4" Hex Head.....	4
16	0708564	Arm, Door Hinge.....	2
17	0501501	Washer, Lock 1/4" Split	2
18	0708527	Door	1
-	0508555	Wiring, Harness, Door Switch.....	1
-	0708526	Door Assy. (includes items 1-6, 18)	

For machines built prior to S/N 6984 order Door Switch Conversion Kit, P/N 0709427.

00004

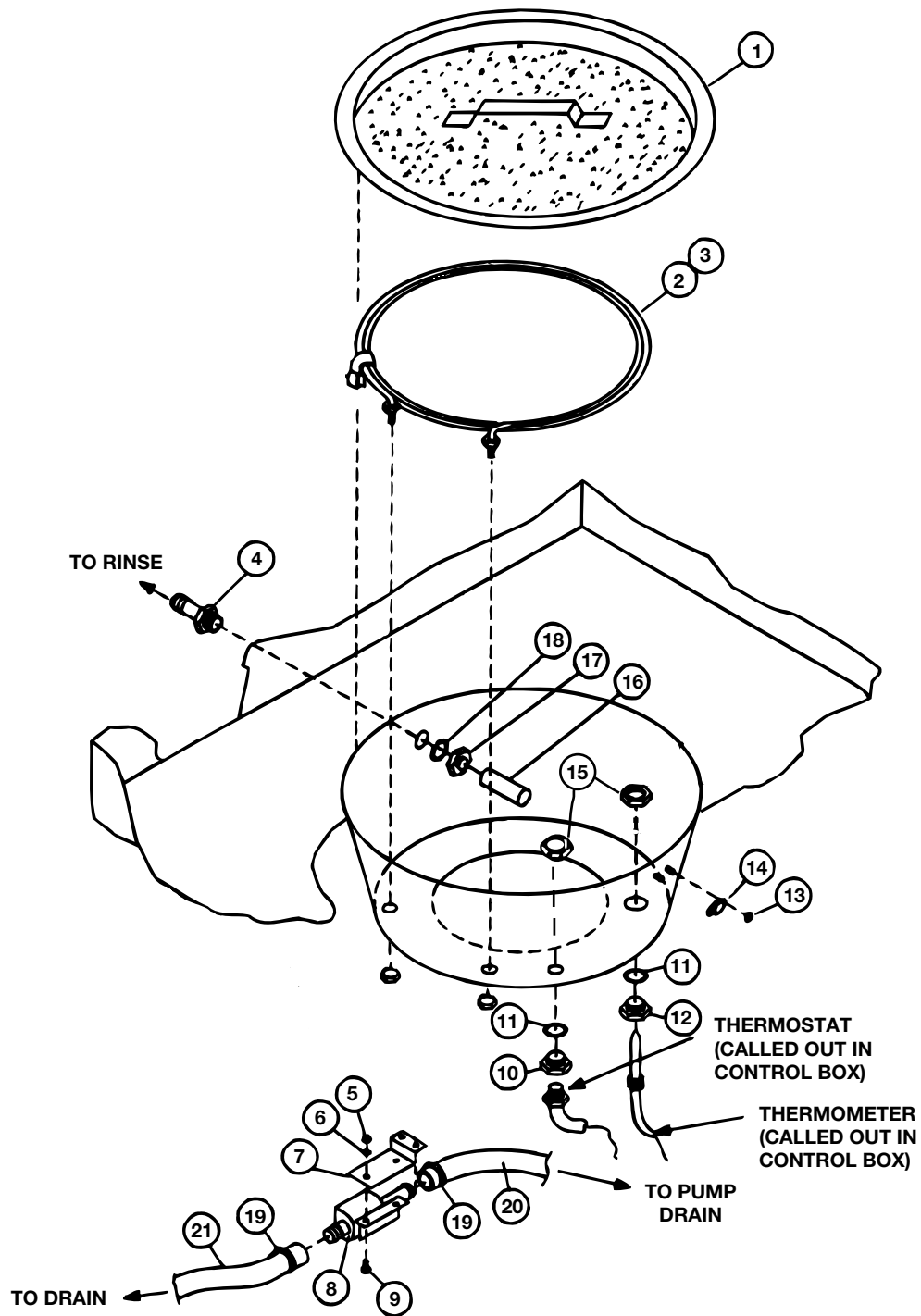

Figure 3 — Tank Heat and Drain

TANK HEAT/DRAIN ASSEMBLY

Fig. 3 Item No.	Part No.	Description	Qty
1	0508628	Scrap Screen.....	1
2	0508536	Heater Element 220V-60Hz-1PH (TUW, UTL).....	1
3	0508537	Heater Element 110V-60Hz-1PH (U-BW, UTL).....	1
4	0508578	Adapter, Pump Tube.....	1
5	0501539	Nut, Plain 1/4-20.....	2
6	0501501	Washer, Lock, 1/4" Split.....	2
7	0308611	Support, Drain Valve.....	1
8	0306618	Valve, Drain.....	1
9	0501418	Screw, 1/4-20 x 1/2" Lg. Round Head.....	2
10	0508873	Adapter, Thermostat.....	1
11	0501836	O-Ring, Thermostat.....	2
12	0508872	Adapter, Thermometer.....	1
13	108954	Nut, Grip 6-32 w/Nylon Insert.....	2
14	110562	Thermostat, High-Limit.....	1
15	201029	Locknut, 1/2 NPT Nickel-Plated.....	2
16	0308655	Tube, Pump Outlet.....	1
17	0508579	Nut, Jam 1"-8.....	1
18	104414	O-Ring.....	1
19	0510082	Clamp, Hose.....	2
20	0507265	Hose, 5/8" ID x 7/8" OD PVC Braided.....	A/R
21	0509302	Hose, 5/8" ID x 1" OD PVC Braided.....	6 Ft.

00005

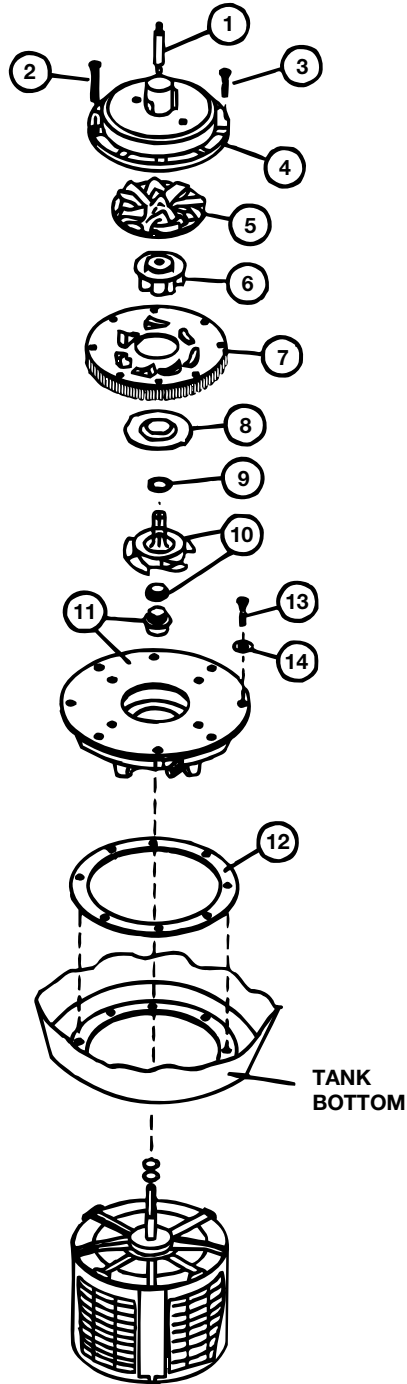

Figure 4 — Pump Assembly

PUMP ASSEMBLY

Fig. 4 Item No.	Part No.	Description	Qty
1	0508542	Spindle, Lower Wash Arm	1
2	0501431	Screw, 8-32 x 1-1/8" Round Head.....	4
3	0501425	Screw, 8-32 x 5/8" Round Head	4
4	0508793	Housing, Diffuser	1
5	0502741	Diffuser.....	1
6	0502704	Impeller	1
7	0502746	Adapter Plate, Suction.....	1
8	0502745	Plate, Drain Inlet.....	1
9	0502703	O-ring	1
10	0502744	Propeller/Rotating Seal Assembly	1
11	0502743	Mounting Plate/Seal Assembly (Includes Item 10).....	1
12	0501881	Gasket, Pump	1
13	0508665	Screw, 10-32 x 5/8" Hex Washer Head	8
14	0508570	Washer, Sealing Teflon.....	8
-	0508539	Pump/Motor Assembly (Includes items 1-11)*	1
-	107966	Nut, Grip 10-32, SST (Not Shown) (For mounting Item 1).....	1

* Motor not available as a separate repair part

00006

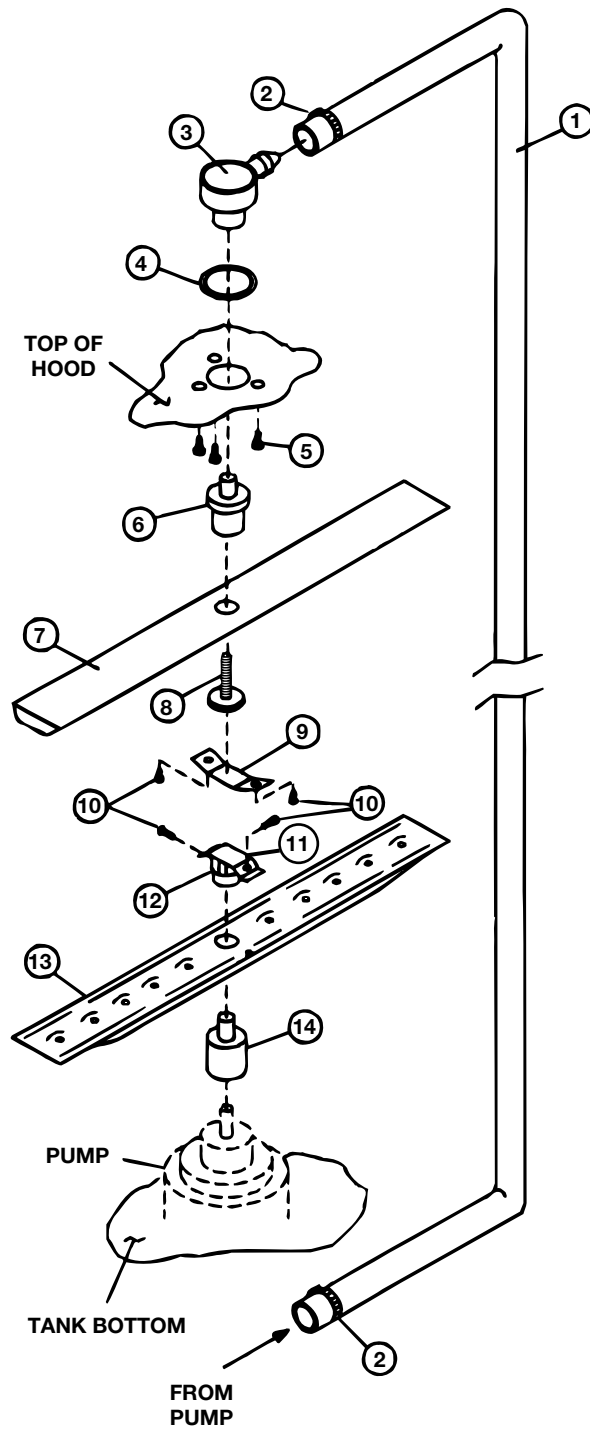

Figure 5 — Wash System Assembly

WASH SYSTEM ASSEMBLY

Fig. 5 Item No.	Part No.	Description	Qty
1	0508549	Hose, Upper Wash	1
2	0502563	Clamp, Hose 1"	2
3	0708650	Spindle, Upper Wash Arm	1
4	0503588	O-ring, 1-1/8" x 1-3/8"	1
5	0501412	Screw, 10-32 x 3/8" Lg. Truss Head	3
6	0508541	Bushing, Upper Wash Arm	1
7	0705047	Wash Arm, Upper	1
8	0505042	Pivot, Upper Wash Arm	1
9	0308783	Retainer, Upper Pivot S/A	1
10	0501563	Screw, #8 x 3/8" (Sheet Metal) Truss Head	4
11	0308158	Nut Clip, Spray Arm	1
12	0501684	Nut, Spray Arm Lock	1
13	0705049	Wash Arm, Lower	1
14	0508540	Bushing, Lower Wash Arm	1
-	0708874	Lower Wash Arm Assembly (includes items 10-14)	

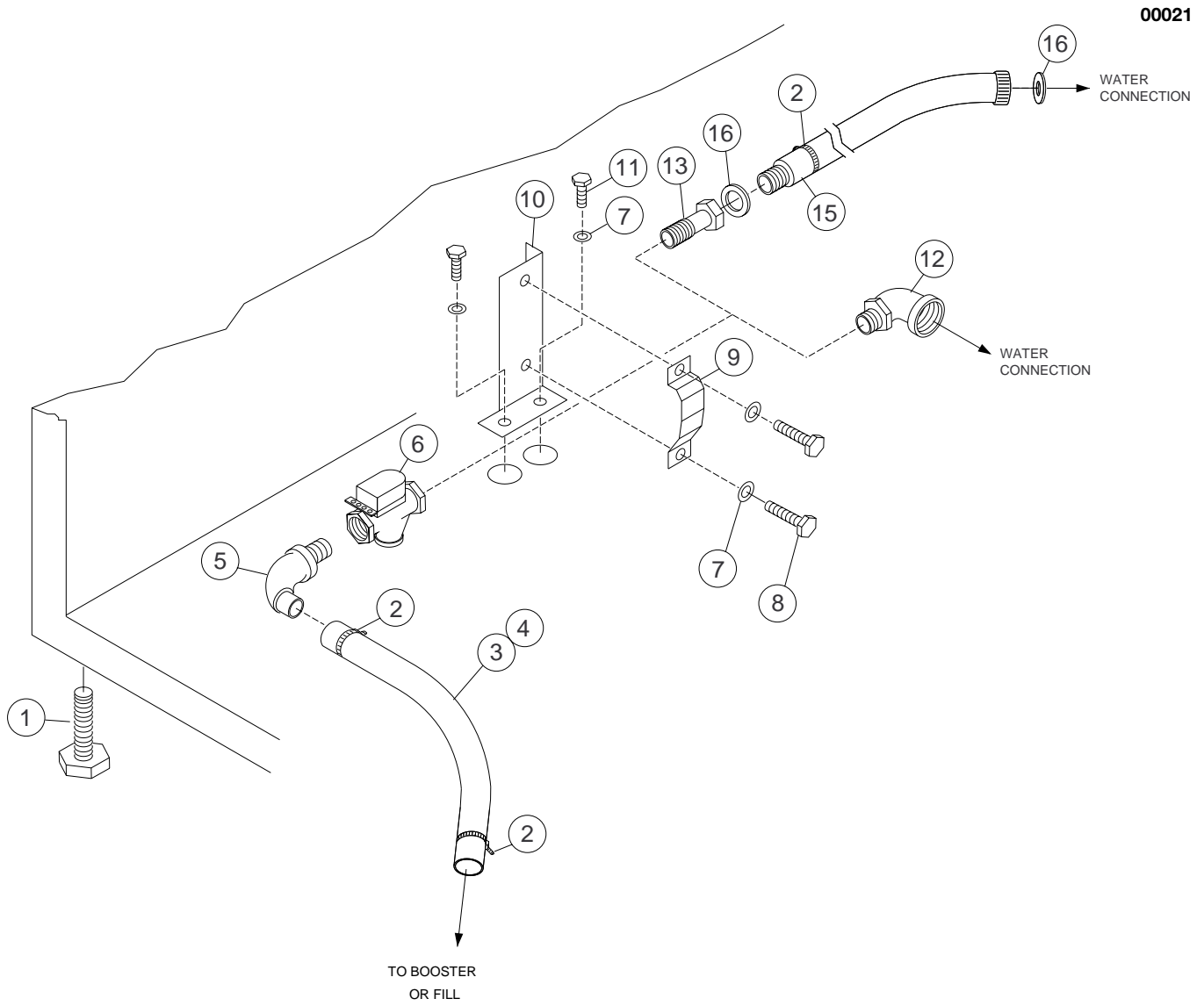

Figure 6 — Water Inlet Piping

WATER INLET PIPING ASSEMBLY

Fig. 6 Item No.	Part No.	Description	Qty
1	0503718	Foot, Adjustable	4
2	0503679	Clamp, Hose	2
3	0502665	Hose 1/2" I.D. Clear-Braided (all except U-BW)	A/R
4	0509214	Hose 1/2" I.D. White (U-BW).....	A/R
5	0502653	Elbow, 3/8 MPT x 1/2" Hose x 90° Brass	1
6	0504952	Valve, Solenoid 3/8 NPT	1
7	0501501	Washer, Lock 1/4" Split.....	4
8	0501419	Bolt, 1/4-20 x 1/2" Lg. Hex Head	2
9	0300203	Clamp, Valve Support	1
10	0300065	Support, Fill Valve.....	1
11	0501424	Bolt, 1/4-20 x 3/8" Lg. Hex Head	2
12	0503713	Elbow, Street 3/8 MPT x 1/2 FPT Brass (TUW, U-BW, UTL).. (Prior to S/N 6795)	1
13	0502618	Coupler, 3/8 MPT x 1/2" Hose barb.....	1
14	0503679	Clamp, Hose (all except TUW, U-BW, UTL)	1
15	0509526	Hose, Coupled 7 ft. (all except TUW, U-BW, UTL).....	1
16	0505320	Washer, Hose (all except TUW, U-BW, UTL)	1
-	0502811	Repair Kit, 3/8" NPT Solenoid Valve (0504952)	
-	0505235	Coil, 115V, 3/8" NPT Solenoid Valve (0504952)	
-	0504958	Flow Washer, 3/8" NPT Solenoid Valve (0504952)	

00018

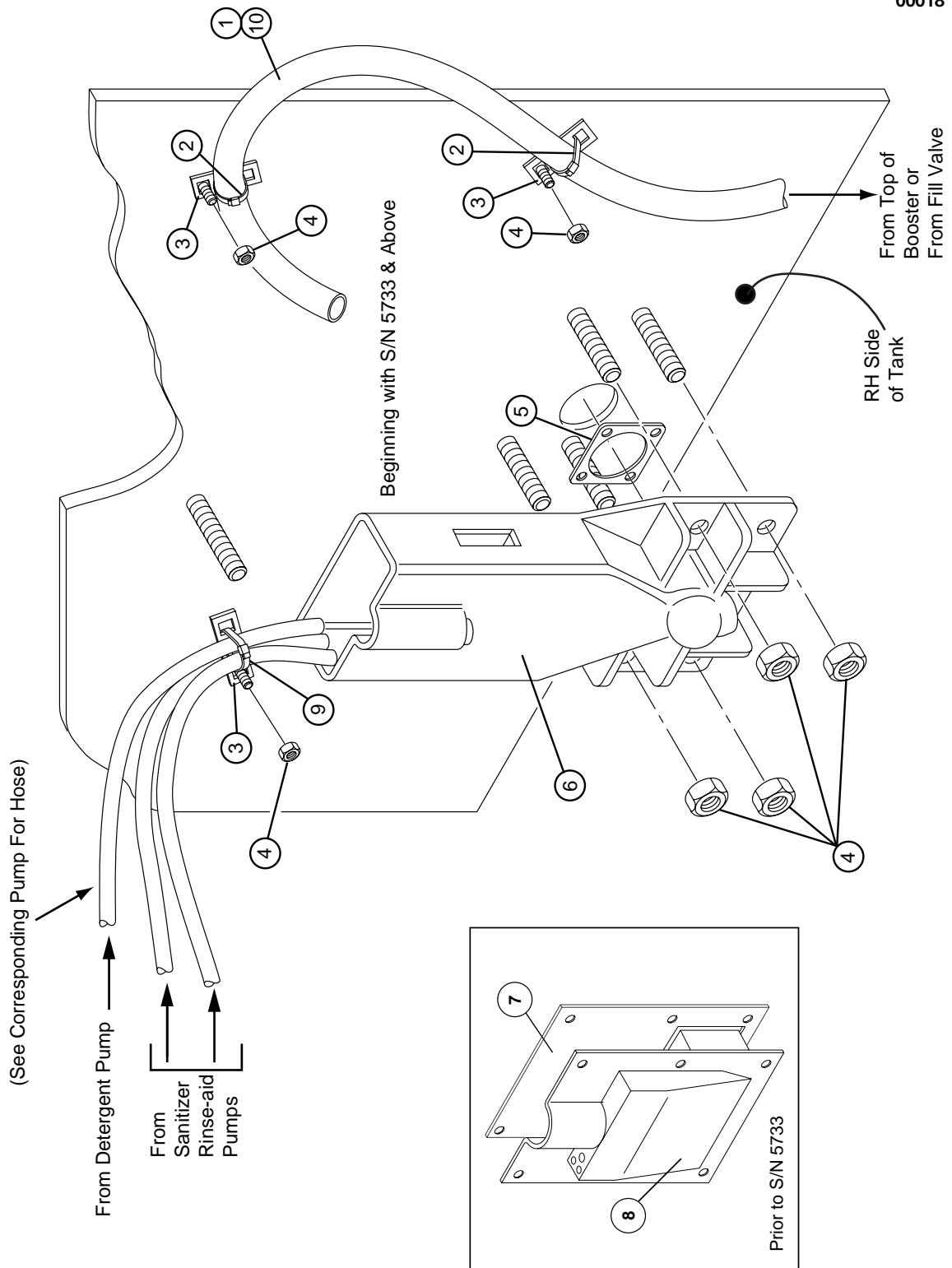

Figure 7 — Fill System

FILL SYSTEM
All Models

Fig. 7 Item No.	Part No.	Description	Qty
1	0502665	Hose, 1/2" I.D. Clear Braided (UTL).....	A/R
2	0501518	Tie Wrap, Hose.....	2
3	106090	Bracket, Tie Wrap	2
4	107966	Nut, Grip, 10-32 w/Nylon Insert	8
5	0509048	Gasket, Inlet Chute (Beginning with S/N 5733 & above).....	1
6	0508867	Inlet Chute (Beginning with S/N 5733 & above).....	1
7	0508656	Gasket, Inlet Chute (Prior to S/N 5733).....	1
8	0508609	Inlet Chute (Prior to S/N 5733).....	1
9	0501519	Tie Wrap, Chemical Hose	3
10	0509214	Hose, Fill 1/2" I.D. (White) (TUW, U-BW).....	3 ft.

00017

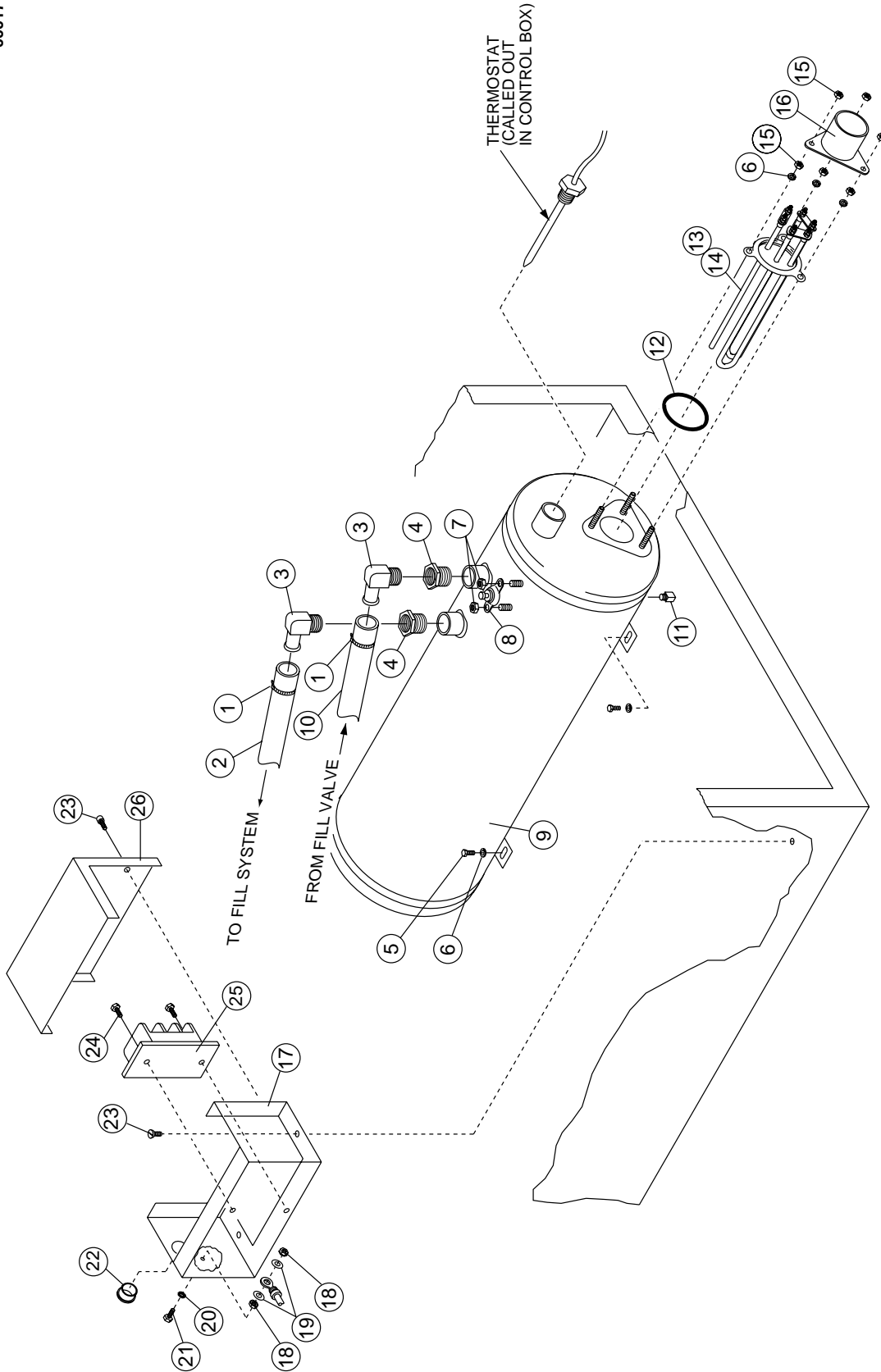

Figure 8 — Booster Assembly

BOOSTER ASSEMBLY
(Includes Models HT, UT, UT-LC)

Fig. 8 Item No.	Part No.	Description	Qty
1	0503679	Clamp, Hose	2
2	0509214	Hose, 1/2" I.D. (42")	3 ft.
3	0502653	Elbow, 3/8 MPT x 1/2" Hose x 90° Brass	2
4	0508840	Bushing, Reducing 3/4 NPT x 3/8 NPT Brass	2
5	0501419	Bolt, 1/4-20 x 1/2" Lg. Hex Head	2
6	0501501	Washer, Lock 1/4" Split.....	5
7	108954	Nut, Grip 6-32 w/Nylon Insert	2
8	110562	Thermostat, High Limit.....	1
9	0508779	Tank, Booster (Prior to S/N 5713).....	1
9	0509042	Tank, Booster (Beginning with S/N 5713 and above).....	1
10	0509214	Hose 1/2" I.D. (28")	A/R
11	0508709	Pipe Plug, 1/8 NPT Brass	1
12	109985	O-Ring.....	1
13	111233	Heater Element, 9KW (70° Rise) 208/230V-60Hz-1Ph.....	1
14	111235	Heater Element, 6KW (40° Rise) 208/230V-60Hz-1Ph.....	1
15	0501539	Nut, Plain 1/4-20	6
16	107908	Cover, Heater Element	1
17	0308638	Body, Junction box	1
18	0501533	Nut, Plain 10-32 Brass	2
19	0501472	Washer, Flat #10 Brass	2
20	0501493	Washer, Lock #10 Ext. Tooth Brass	1
21	0501403	Screw, 10-32 x 3/4" Lg. Round Head Brass.....	1
22	107964	Bushing, Snap.....	1
23	0501412	Screw, 10-32 x 3/8" Lg. Truss Head.....	4
24	0504538	Screw, 10-32 x 3/8" Lg. Truss Head Steel.....	2
25	0504951	Terminal Block	1
26	0308627	Cover, Junction Box	1
-	110997	Wire, Jumper, Heater Element (Not Shown).....	1
-	0307356	Insulation, Heater Terminal (Not Shown)	1

00022

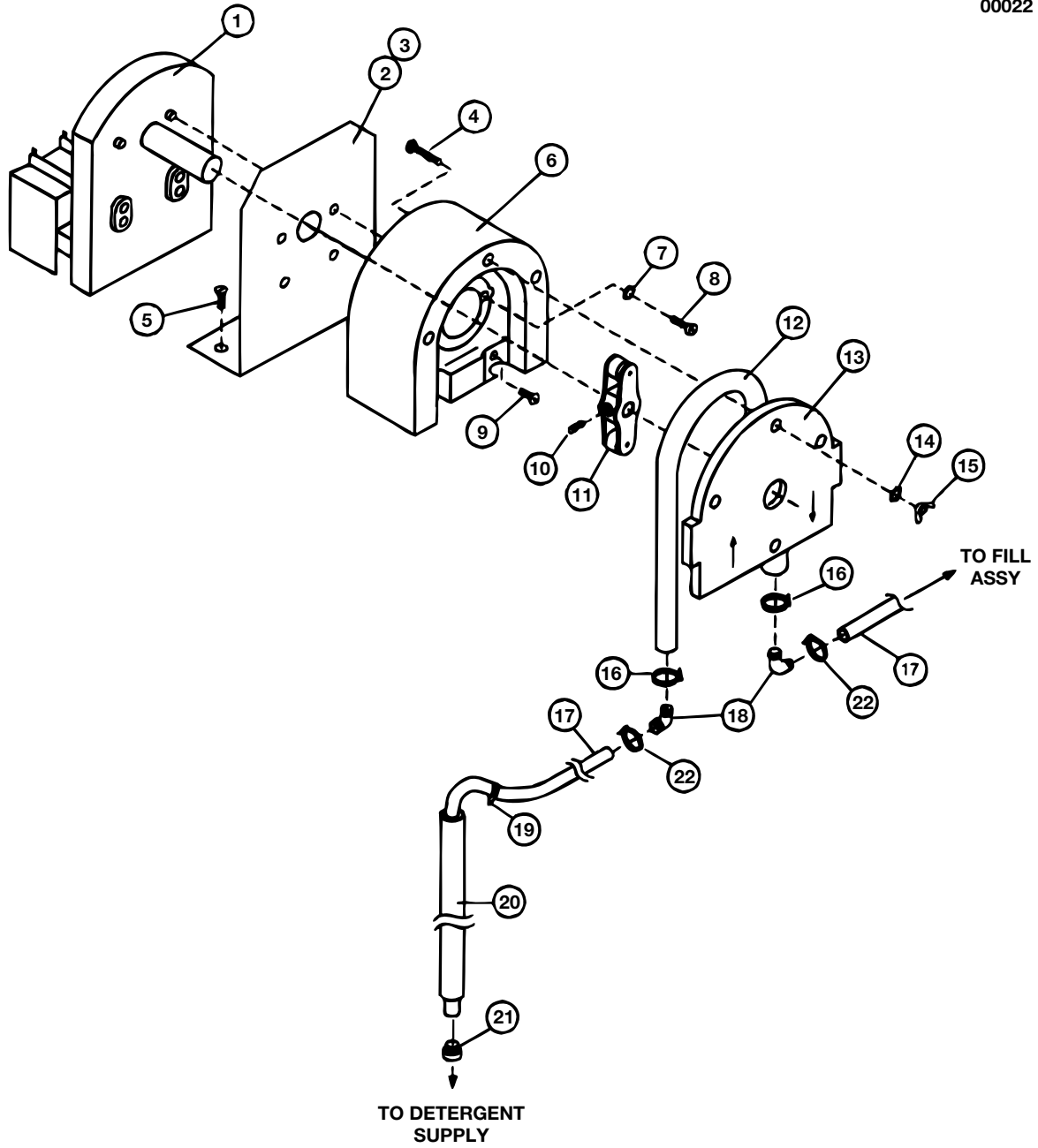

Figure 9 — Detergent Pump Assembly

DETERGENT PUMP ASSEMBLY
All Models

Fig. 9 Item No.	Part No.	Description	Qty
1	0503757	Motor, Pump.....	1
2	0308637	Bracket, Detergent Pump (TUW, U-BW)	1
3	0308610	Bracket, Detergent/Sanitizer Pumps (UTL)	1
4	N/A	Screw, M4 x 35mm Hex Head	4
5	0501412	Screw, 10-32 x 3/8" Lg. Truss Head.....	2
6	N/A	Housing, Pump	1
7	0501497	Washer, Lock #8 Split	2
8	0504822	Screw, 8-32 x 1/2" Lg. Pan Head	2
9	0501425	Screw, 8-32 x 5/8" Round Head	2
10	N/A	Screw, Set M6 x 8mm	1
11	N/A	Rotor Assembly.....	1
12	108194	Hose, Pump	1
13	N/A	Cover, Pump Housing	1
14	N/A	Washer, Flat M4	4
15	N/A	Nut, Wing M4.....	4
16	0501519	Tie Wrap, Hose.....	2
17	0502667	Hose, Detergent, 1/4" I.D. PVC (Clear).....	A/R
18	0502644	Elbow, 1/4" O.D. x 90° Barbed	2
19	0503695	Label, Detergent	1
20	0306363	Tube, Pick-Up	1
21	0501869	Strainer, Pick-Up Tube	1
22	0501519	Tie Wrap, Hose.....	2
-	109829	Pump Head Assy. (includes items 4, 6, 10-15)	
-	0708559	Pump/Motor Assy. (includes items 1, 2, 4, 6-16, 18)	

00002

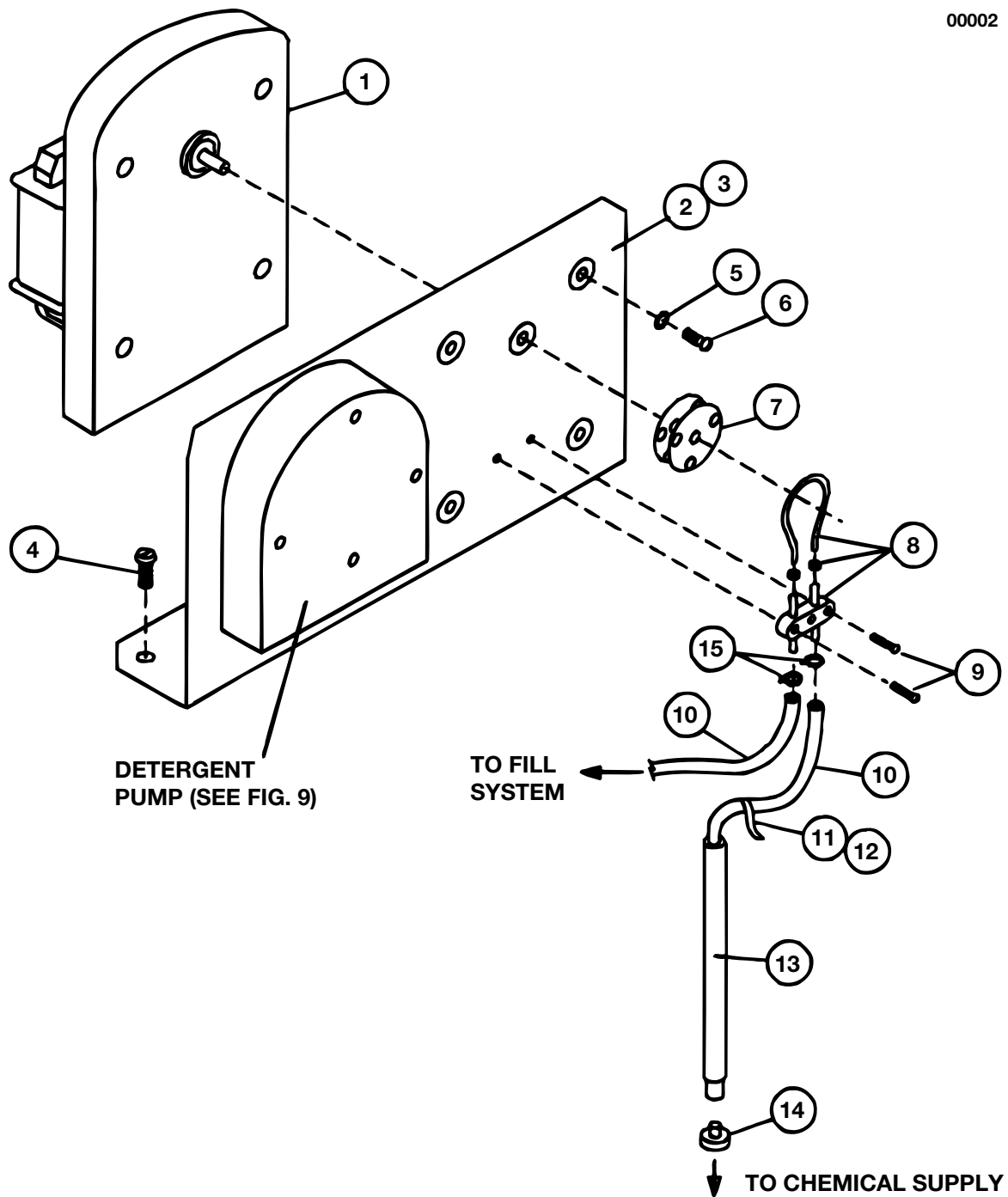

Figure 10 — Sanitizer/Rinse Aid Pump Assembly

**SANITIZER/RINSE AID PUMP
LT/UTL**

Fig. 10 Item No.	Part No.	Description	Qty
1	0503756	Motor, Pump.....	1
2	0308610	Bracket, Detergent/Sanitizer Pump (UTL).....	1
3	0308697	Bracket, Rinse-Aid Pump (Optional).....	1
4	0501412	Screw, 10-32 x 3/8" Lg. Truss Head.....	2
5	0501497	Washer, Lock #8 Split	4
6	0504822	Screw, 8-32 x 1/2" Lg. Pan Head	4
7	0707142	Rotor Assy.....	1
8	0706635	Element Tube Assy (45 ^{cc} /min).....	1
9	0506589	Screw, 6-32 x 7/8" Lg. Pan Head	2
10	0502666	Hose, 1/8" I.D. PVC (Clear).....	A/R
11	0503694	Label, Sanitizer (UTL)	1
12	0505483	Label, Rinse-Aid (Optional).....	1
13	0306363	Tube, Pick-Up	1
14	0501869	Strainer, Pick-up Tube	1
15	0501519	Tie Wrap, Hose.....	2
-	0708561	Detergent/Sanitizer Pump Assy. (UTL)	1
		(Includes Detergent Pump and Items 2, 5-9)	
-	0708754	Rinse-Aid Pump Assy. (Optional)	
		(Includes Items 1,3, 5-10, 12-15)	

00003

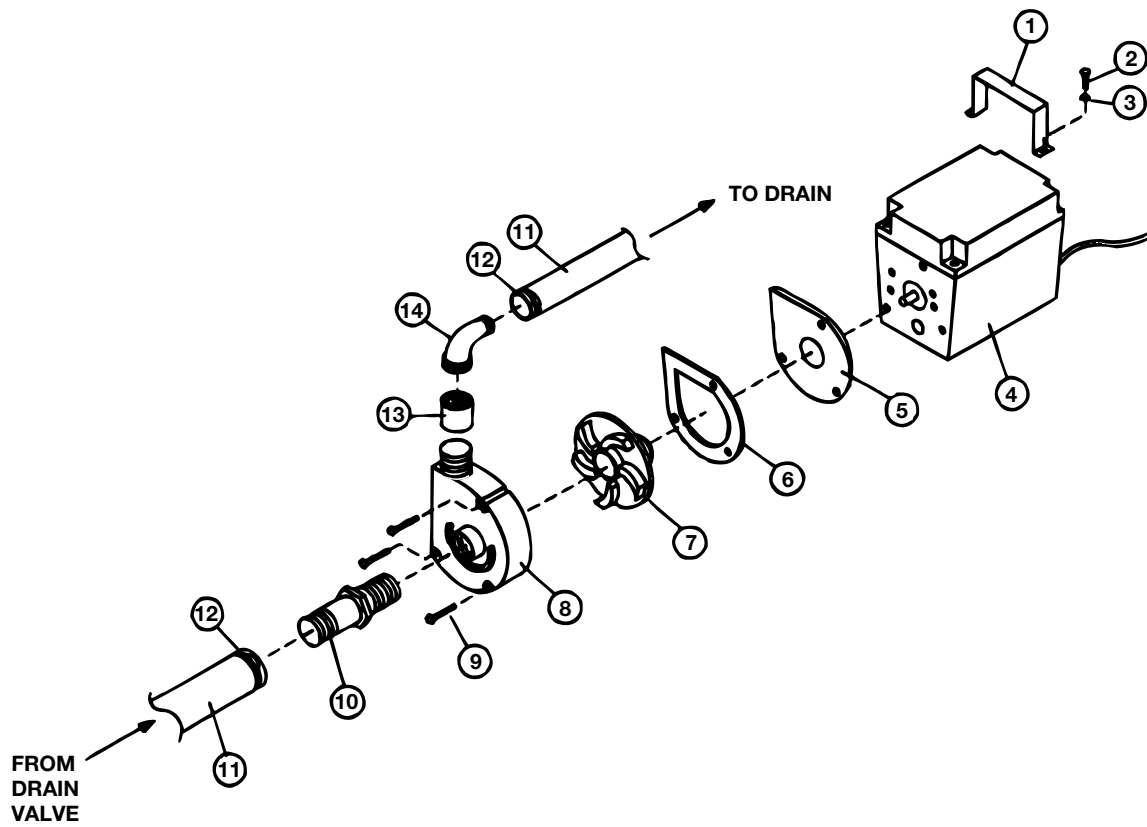

Figure 11 — Drain Pump Assembly

DRAIN PUMP ASSEMBLY
501 UTL, UT-LC

Fig. 11	Part	Description	Qty
Item No.	No.		
1	0308119	Bracket, Pump Hold Down	1
2	0501419	Bolt, 1/4-20 x 1/2" Lg. Hex Head	2
3	0501501	Washer, Lock 1/4" Split.....	2
4	N/A	Motor, Pump.....	1
5	N/A	Backing Plate, Pump	1
6	0508370	Gasket, Pump Volute	1
7	0508369	Impeller, Pump	1
8	0508368	Volute, Pump	1
9	N/A	Screw, 10-24 x 1-5/8" Lg. Pan Head	3
10	0508141	Adapter, 3/4 MPT x 1/2" Hose Barb PVC	1
11	0507265	Hose, 5/8" I.D. x 7/8 O.D., Braided	A/R
12	0503679	Clamp, Hose	2
13	0508139	Coupling, 1/2" NPT PVC.....	1
14	0508140	Elbow, 1/2 MPT x 1/2" Hose Barb x 90° PVC	1
-	C35065	Drain Pump Assy. (Includes Items 4-9) (UTL)	

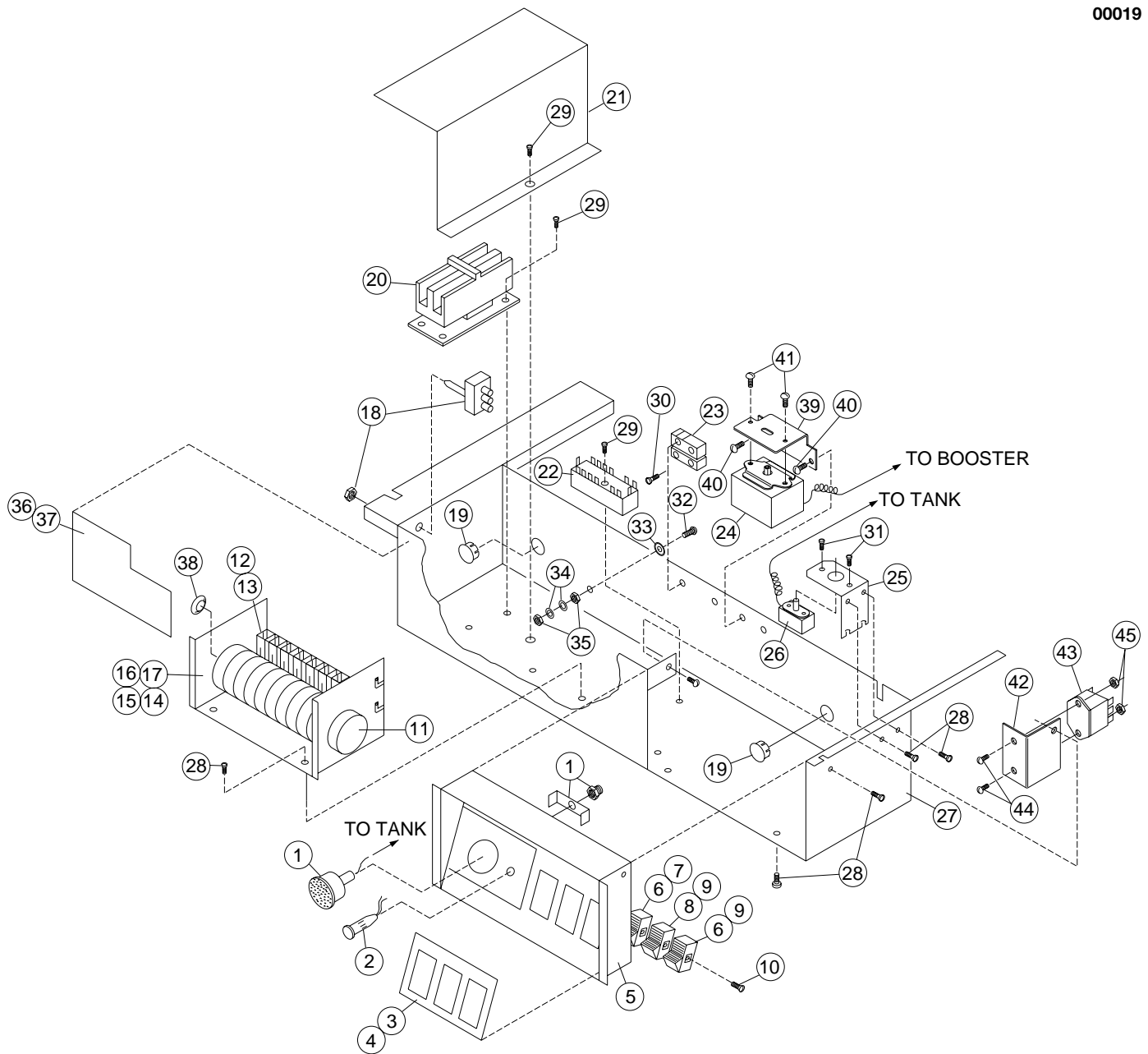

Figure 12 — Control Cabinet

**CONTROL CABINET ASSEMBLY
TUW, U-BW, UTL**

Fig. 12 Item No.	Part No.	Description	Qty
1	108391	Thermometer, 48"	1
2	0508551	Lamp, Green.....	1
3	0508552	Decal, Control Panel (All except TUW, U-BW).....	1
4	0508553	Decal, Control Panel (UTL)	1
5	0708635	Control Panel.....	1
6	0501361	Switch, Rocker (TUW, U-BW)	2
7	0501361	Switch, Rocker (UTL).....	1
8	0501369	Switch, Rocker, Spring-Return (TUW, U-BW)	1
9	0501369	Switch, Rocker, Spring Return (UTL)	2
10	0504911	Screw #6 x 1/4" Lg. (Sheet Metal) Pan Head.....	6
11	0504956	Motor, Timer	1
12	0501379	Switch, Timer (TUW, U-BW)	8
13	0501379	Switch, Timer (UTL).....	9
* 14	0708538	Timer Assy (includes items 11, 12, 38) (TUW, U-BW).....	1
* 15	0708590	Timer Assy (includes items 11, 13, 38) (UTL)	1
* 16	0708590	Timer Assy (includes items 11, 13, 38) (UTL)	1
* 17	—	No Longer Available	
18	0501373	Switch, Toggle, 3 Position (TUW)	1
19	107964	Bushing, Snap.....	2
20	0508554	Contact, 2 Pole, 50 AMP (240V) (TUW)	1
21	0308641	Cover, Contactor (TUW).....	1
22	0503749	Terminal Block	1
23	0501358	Relay, Start	1
24	109069	Thermostat, Booster w/Capillary	1
24	112204	NA	1
25	0300096	Bracket, Tank Heat, Thermostat.....	1
26	0501380	Thermostat, Tank Heat, w/Capillary Wash Tank.....	1
27	0708525	Control Box	1
28	0501412	Screw, 10-32 x 3/8" Lg. Truss Head.....	11
29	0503648	Screw, 8-32 x 1/4" Lg. Pan Head	4
30	0501463	Screw, 8-32 x 1" Lg. Round Head.....	1
31	0501450	Screw, 6-32 x 1/4" Lg. Round Head.....	2
32	0501403	Screw, 10-32 x 3/4" Lg. Round Head Brass.....	1
33	0501493	Washer, Lock #10 Ext. Tooth	1
34	0501472	Washer, Flat #10 Brass	2
35	0501533	Nut, Plain 10-32 Brass	2
36	0508572	Label, Cam (TUW, U-BW)	1
37	0508589	Label, Cam (UTL).....	1

* Not a service replacement part assembly
Wire Harness 0508556

CONTROL CABINET ASSEMBLY (cont'd)
TUW, U-BW, UTL

Fig. 12 Item No.	Part No.	Description	Qty
38	0503701	Bearing, Timer Shaft	1
-	0501292	Power Cord (U-BW, UTL) (Not Shown)	1
39	112185	Bracket, Ranco thermostat	1
40	—	Sheetmetal screw (#8 x 3/16")	2
41	—	Screw (6/32 x 1/4")	2
42	0309433	Bracket, Relay	1
43	0509428	Relay (15A, 120VAC)	1
44	0501408	Screw (8-32 x 1/4")	2
45	0501538	Nut, (8-3/2 Hex)	2

ELECTRICAL SCHEMATICS

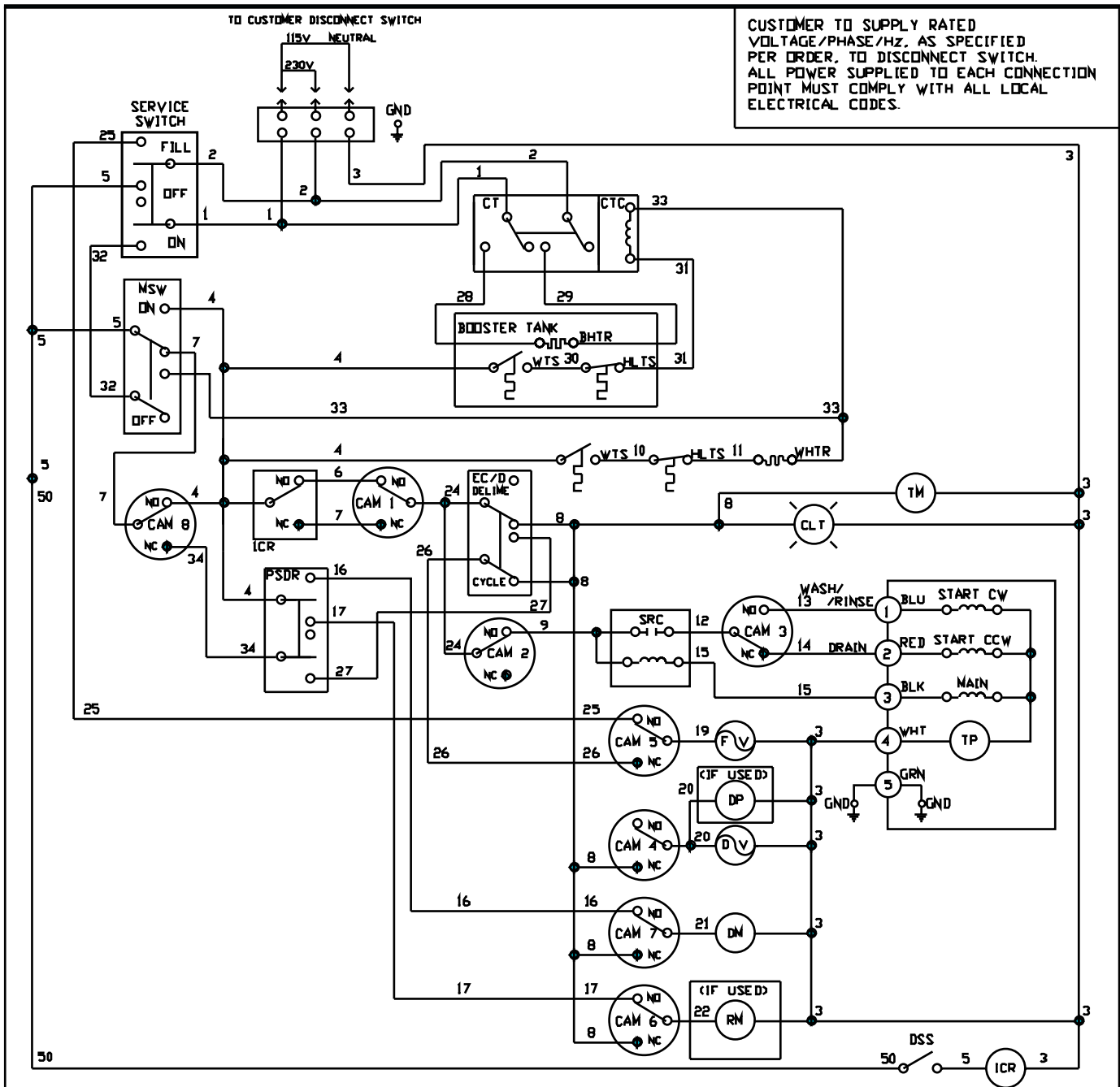

BHTR	BOOSTER HEATER	CT	CONTACTOR	PSDR	PRIME SWITCH DETERGENT, RINSE
BLK	BLACK	CTC	CONTACTOR COIL	ICR	RELAY
BLU	BLUE	DM	DETERGENT MOTOR	DDS	DOOR SAFETY SWITCH
CAM 1	FILLING	DP	DRAIN PUMP (IF USED)	RM	RINSE MOTOR (IF USED)
CAM 2	PUMP MOTOR	DS	DOOR SWITCH	SS	SERVICE SWITCH
CAM 3	PUMP MOTOR REVERSING	DV	DRAIN VALVE	TN	TIMER MOTOR
CAM 4	DRAIN	EC/D	EXTENDED CYCLE/DELIME	TP	THERMAL PROTECTOR
CAM 5	FILL	FV	FILL VALVE	WHT	WHITE
CAM 6	RINSE	GND	GROUND	WHTR	WATER HEATER
CAM 7	DETERGENT	GRN	GREEN	WTS	WATER THERMOSTAT
CAM 8	CYCLE	HLTS	HIGH LIMIT THERMOSTAT		
CLT	CYCLE ON LIGHT	NSW	MAIN SWITCH ON/FILL OFF/DRAIN		

HEAT	MODEL	DATE	NUMBER/REV
ELEC		11-10-97	0508571 F

Figure 13 - Electrical Diagram, TUV
(For machines beginning with S/N 6984)

CUSTOMER TO SUPPLY RATED VOLTAGE/PHASE/HZ, AS SPECIFIED PER ORDER, TO DISCONNECT SWITCH. ALL POWER SUPPLIED TO EACH CONNECTION POINT MUST COMPLY WITH ALL LOCAL ELECTRICAL CODES.

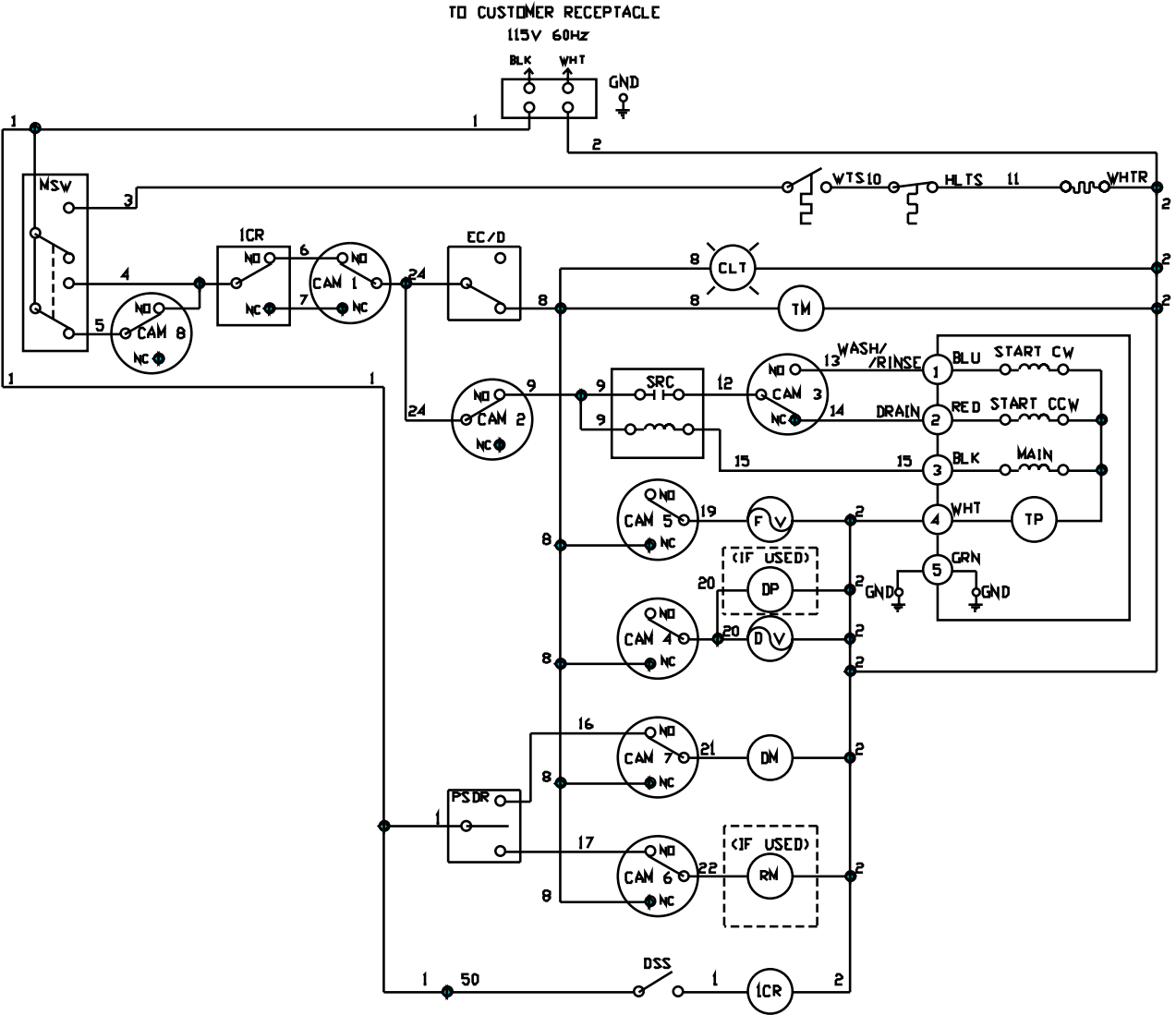

BLK	BLACK	DM	DETERGENT MOTOR	ICR	RELAY
BLU	BLUE	DP	DRAIN PUMP (IF USED)	DSS	REED SWITCH
CAM 1	HOMING	DV	DRAIN VALVE	SRC	CURRENT OPERATED START RELAY COIL
CAM 2	PUMP MOTOR	EC/D	EXTENDED CYCLE/DELIME	TM	TIMER MOTOR
CAM 3	PUMP MOTOR REVERSING	FV	FILL VALVE	TP	THERMAL PROTECTOR
CAM 4	DRAIN	GND	GROUND	WHT	WHITE
CAM 5	FILL	GRN	GREEN	WHTR	WATER HEATER
CAM 6	RINSE	HTLS	HIGH LIMIT THERMOSTAT	WTS	WATER THERMOSTAT
CAM 7	DETERGENT	NSW	MAIN SWITCH ON/FILL OFF/DRAIN		
CAM 8	CYCLE	PSDR	PRIME SWITCH DETERGENT, RINSE		
CLT	CYCLE ON LIGHT	RM	RINSE MOTOR (IF USED)		
		HEAT	MODEL	DATE	NUMBER/REV
		ELEC		05-23-96	0508729 D

Figure 14 - Electrical Diagram, U-BW (For machines beginning with S/N 6984)

CUSTOMER TO SUPPLY RATED VOLTAGE/PHASE/HZ, AS SPECIFIED PER ORDER, TO DISCONNECT SWITCH. ALL POWER SUPPLIED TO EACH CONNECTION POINT MUST COMPLY WITH ALL LOCAL ELECTRICAL CODES.

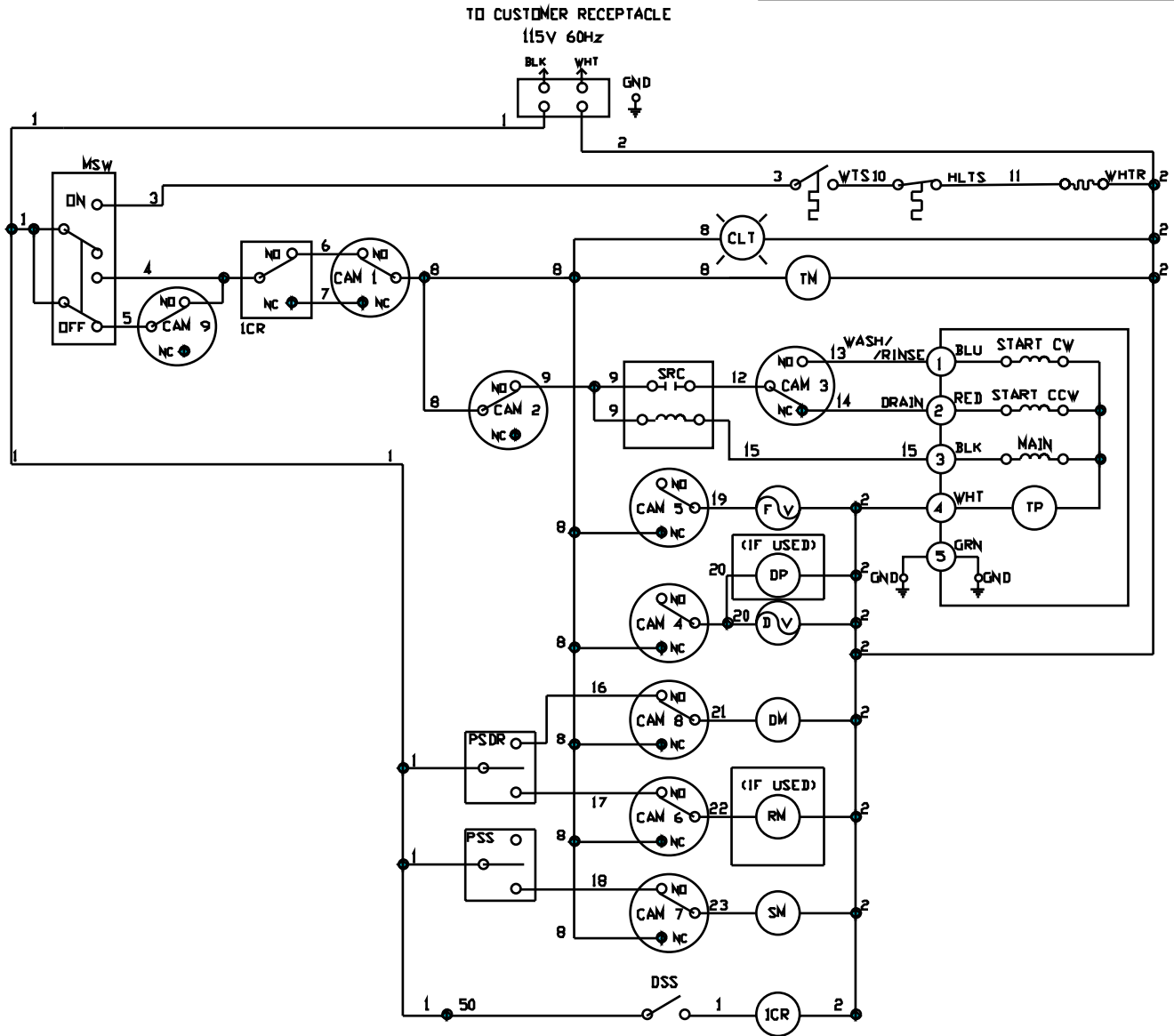

BLK	BLACK	CLT	CYCLE ON LIGHT	PSS	PRIME SWITCH SANITIZER
BLU	BLUE	DM	DETERGENT MOTOR	ICR	RELAY
CAM 1	HOMING	DP	DRAIN PUMP (IF USED)	DSS	REED SWITCH
CAM 2	PUMP MOTOR	RL	RELAY	RM	RINSE MOTOR (IF USED)
CAM 3	PUMP MOTOR REVERSING	DV	DRAIN VALVE	SRC	CURRENT OPERATED START RELAY COIL
CAM 4	DRAIN	FV	FILL VALVE	SM	SANITIZER MOTOR
CAM 5	FILL	GND	GROUND	TM	TIMER MOTOR
CAM 6	RINSE	GRN	GREEN	TP	THERMAL PROTECTOR
CAM 7	SANITIZER	HTLS	HIGH LIMIT THERMOSTAT	WHT	WHITE
CAM 8	DETERGENT	MSW	MAIN SWITCH ON/FILL OFF/DRAIN	WHTR	WATER HEATER
CAM 9	CYCLE	PSDR	PRIME SWITCH DETERGENT, RINSE	WTS	WATER THERMOSTAT
		HEAT	MODEL	DATE	NUMBER/REV
		ELEC		11/10/97	0508586 E

Figure 15 - Electrical Diagram, UTL
(For machines beginning with S/N 6984)

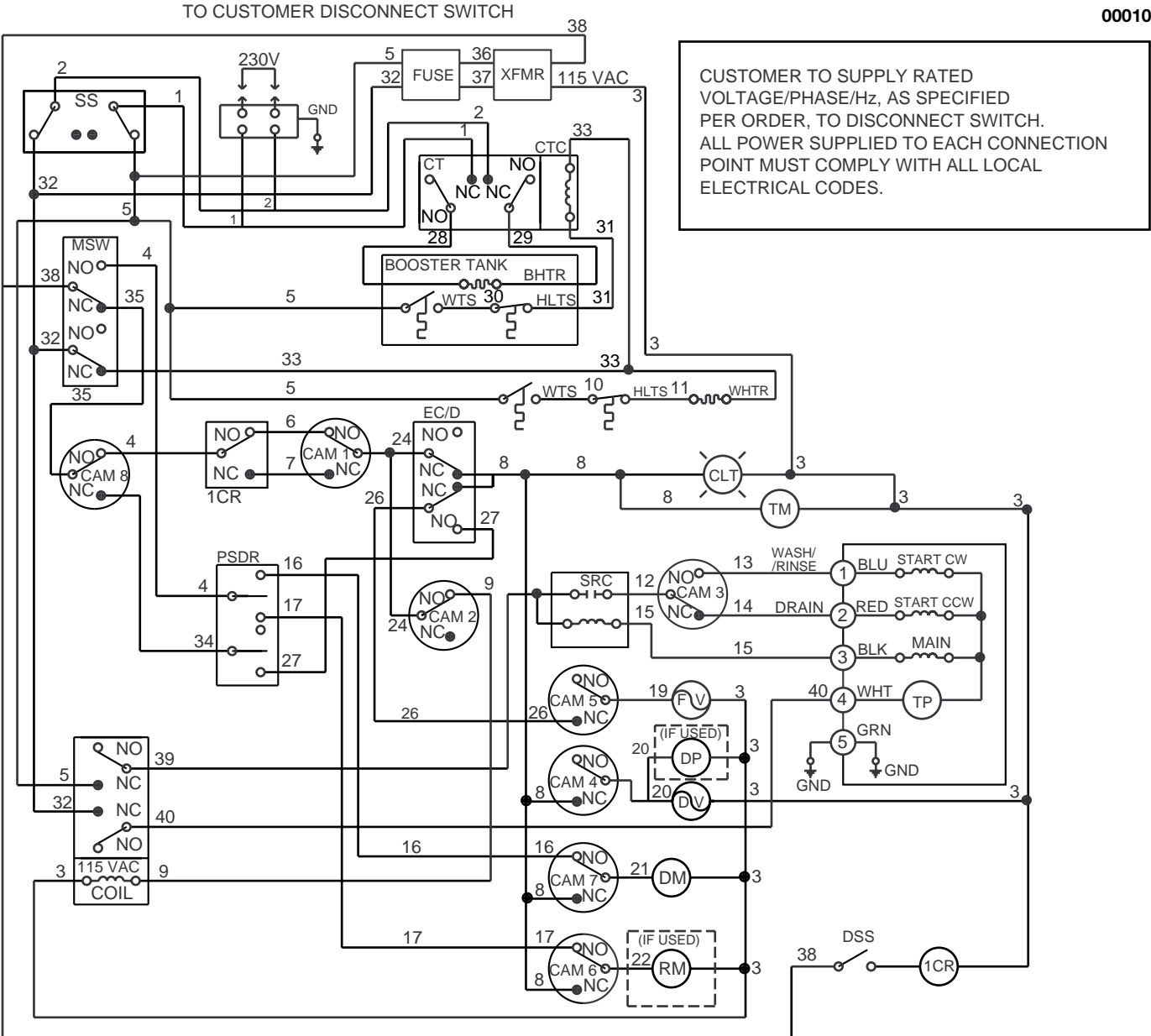

BHTR	BOOSTER HEATER	CT	CONTACTOR	PSDR	PRIME SWITCH DETERGENT, RINSE
BLK	BLACK	CTC	CONTACTOR COIL	1CR	RELAY
BLU	BLUE	DM	DETERGENT MOTOR	RM	RINSE MOTOR (IF USED)
CAM 1	HOMING	DP	DRAIN PUMP (IF USED)	SRC	CURRENT OPERATED START RELAY COIL
CAM 2	PUMP MOTOR	DSS	DOOR SAFETY SWITCH	SS	SERVICE SWITCH
CAM 3	PUMP MOTOR REVERSING	DV	DRAIN VALVE	TM	TIMER MOTOR
CAM 4	DRAIN	EC/D	EXTENDED CYCLE/DELIME	TP	THERMAL PROTECTOR
CAM 5	FILL	FV	FILL VALVE	WHT	WHITE
CAM 6	RINSE	GND	GROUND	WHTR	WATER HEATER
CAM 7	DETERGENT	GRN	GREEN	WTS	WATER THERMOSTAT
CAM 8	CYCLE	HLTS	HIGH LIMIT THERMOSTAT		
CLT	CYCLE ON LIGHT	MSW	MAIN SWITCH ON/FILL OFF/DRAIN		

0508975/A

Figure 16 - Electrical Diagram, TUW (50 Hz)

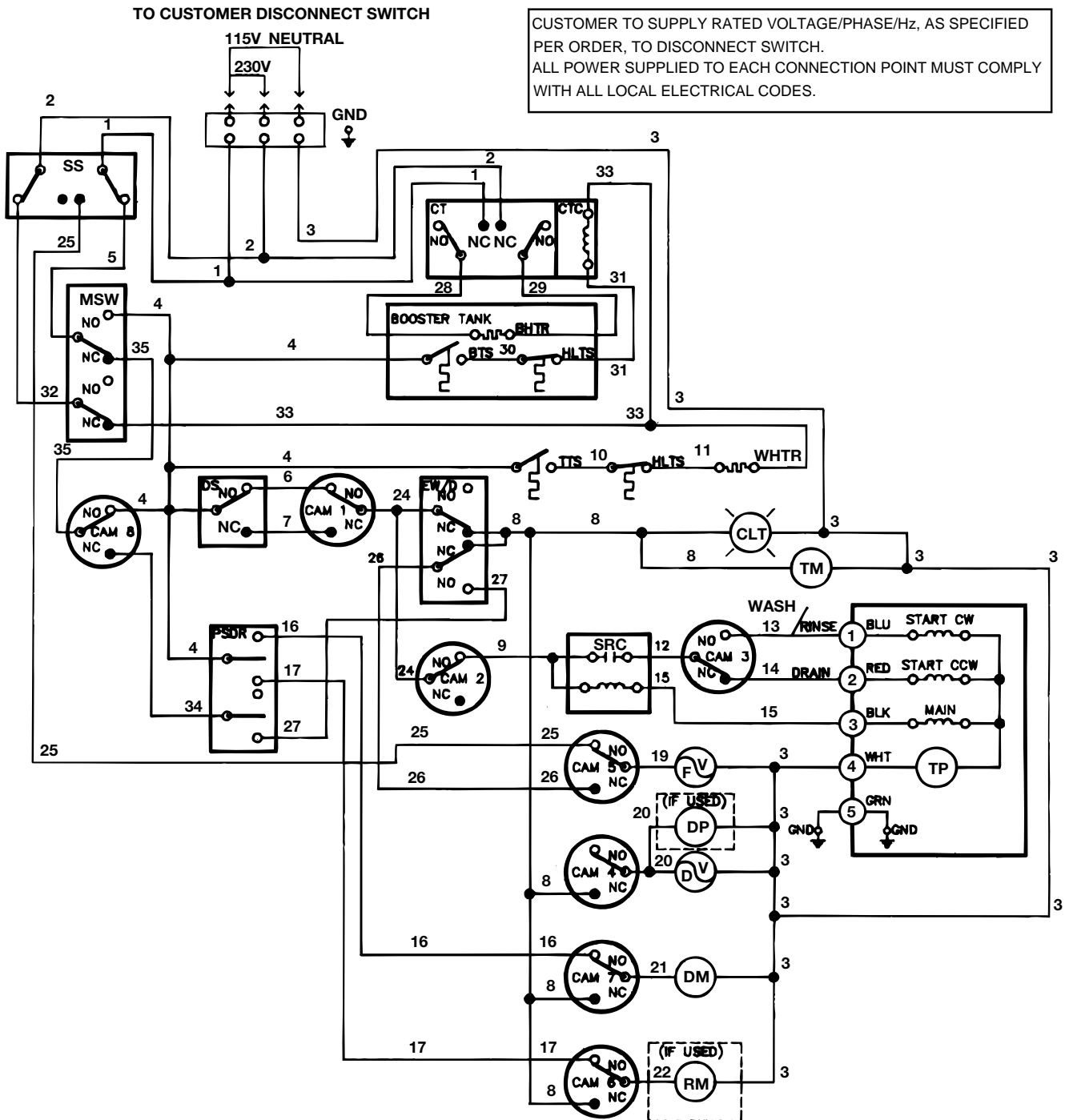
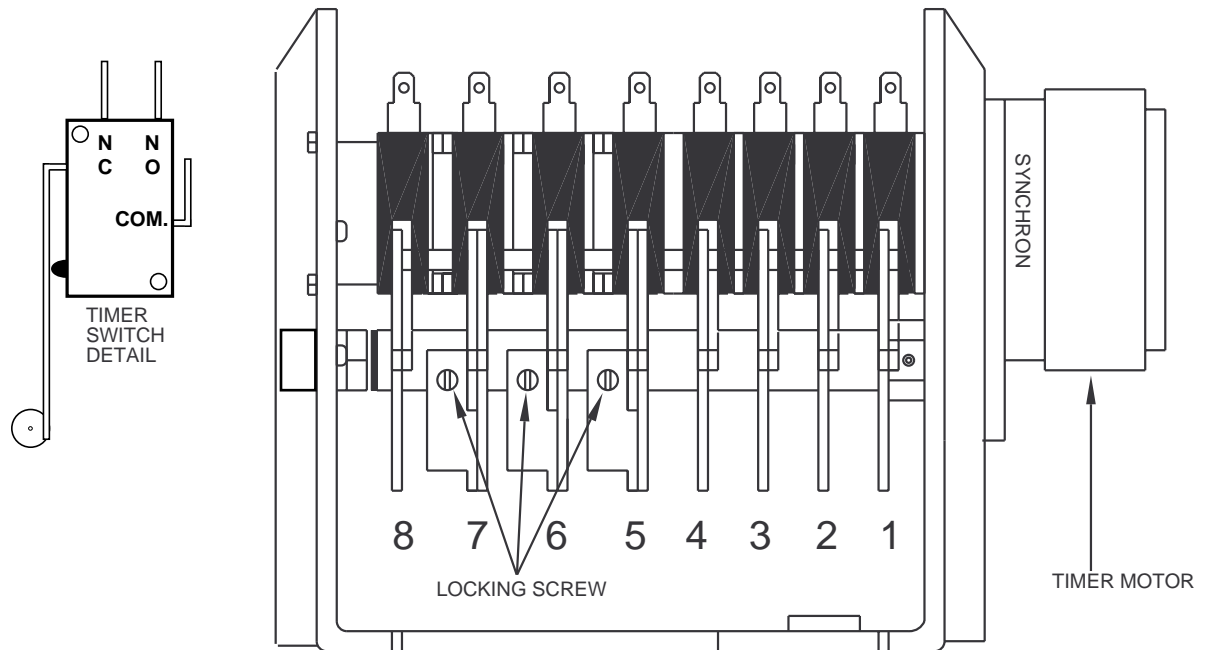

Figure 17 - Electrical Diagram, TUV
(For machines built prior to S/N 6984)

TIMING CHART TUW, U-BW

CAM	TIME IN SECS	0	10	20	30	40	50	60	70	80	90	100	110	120	130	140	150	
1	HOMING CAM																	
2	WASH PUMP FORWARD=WASH																	
2	WASH PUMP REVERSE=DRAIN																	
3	WASH PUMP REVERSING CAM																	
4	DRAIN VALVE DRAIN PUMP																	
5	FILL VALVE																	
6	RINSE PUMP OPTIONAL																	
7	DETERGENT PUMP																	
8	AUTO-FILL DRAIN																	



TIMER ASSEMBLY TUW, U-BW

Figure 18 - Timer Chart and Diagram, TUW, U-BW

TIMING CHART UTL

CAM	TIME IN SECS	0	10	20	30	40	50	60	70	80	90	100	110	120	130	140	150	
1	HOMING CAM																	
2	WASH PUMP FORWARD=WASH		█	█	█	█	█	█	█	█	█	█	█	█	█	█	█	█
2	WASH PUMP REVERSE=DRAIN										█	█	█	█	█	█	█	█
3	WASH PUMP REVERSING CAM									█	█	█	█	█	█	█	█	█
4	DRAIN VALVE DRAIN PUMP									█	█	█	█	█	█	█	█	█
5	FILL VALVE													█	█	█	█	█
6	RINSE PUMP													█	█	█	█	█
7	SANITIZER PUMP													█	█	█	█	█
8	DETERGENT PUMP	█	█	█	█	█	█	█	█	█	█	█	█	█	█	█	█	█
9	AUTO-FILL DRAIN													█	█	█	█	█

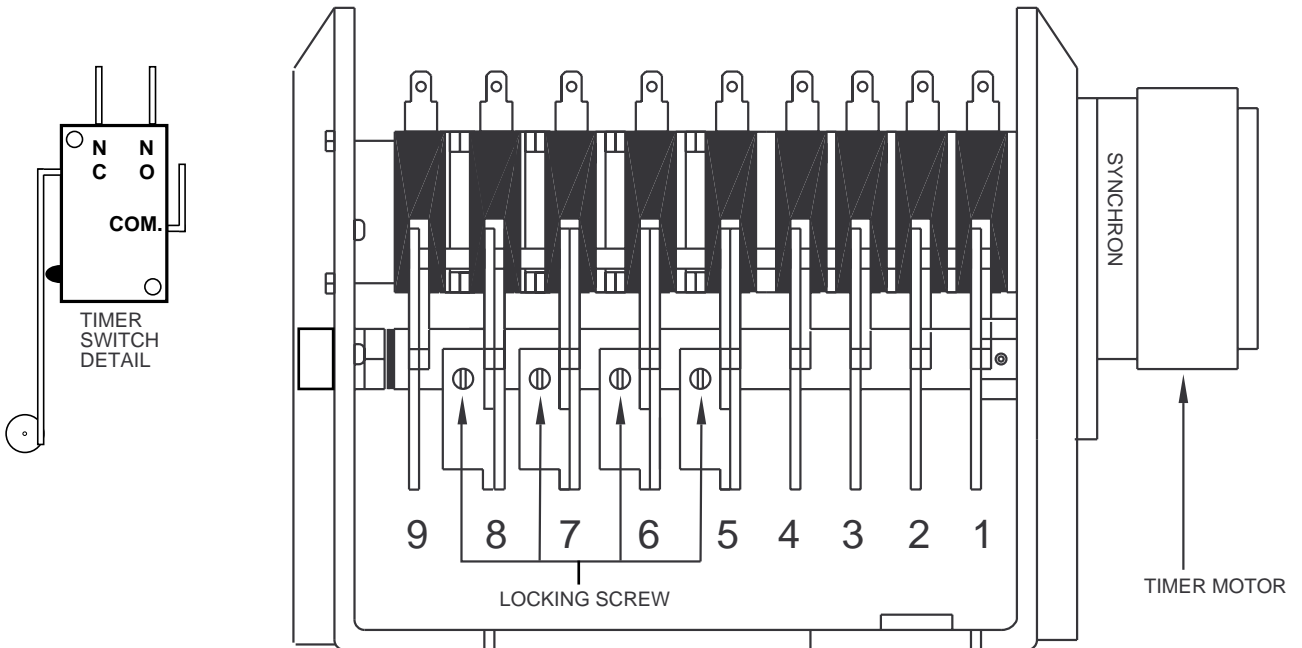

TIMER ASSEMBLY UTL

Figure 19 - Timer Chart and Diagram, UTL