Champion[®]

The Dishwashing Machine Specialists

For machines beginning with Serial no. 89788

Technical Manual

Upright Conveyor Dishwasher

M1
Model
UC-CW
30" Conveyor

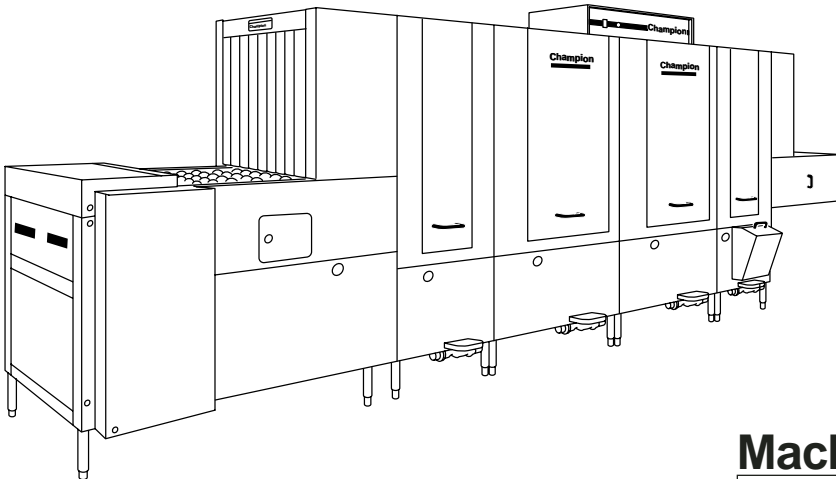

Machine Serial No.

August, 2003

Manual P/N 113160 Rev. G

P.O. Box 4149
Winston-Salem, North Carolina 27115-4149
336/661-1556 Fax: 336/661-1660

2674 N. Service Road
Jordan Station, Ontario, Canada L0R 1S0
905/562-4195 Fax: 905/562-4618

www.championindustries.com

Complete the information below so it will be available for quick reference.

Model Number _____ Serial Number _____

Voltage and Phase _____

Champion Parts Distributor _____ Phone _____

Champion Service Agency _____ Phone _____

**Champion (USA)
National Service Department**

Phone: 1(800) 858-4477
Fax: 1(336) 661-1660

**Champion (Canada)
National Service Department**

Phone: 1(800) 263-5798
Fax: 1(905) 562-4618

NOTE: When calling to order parts, be sure to have the model number, serial number, voltage, and phase of your machine.

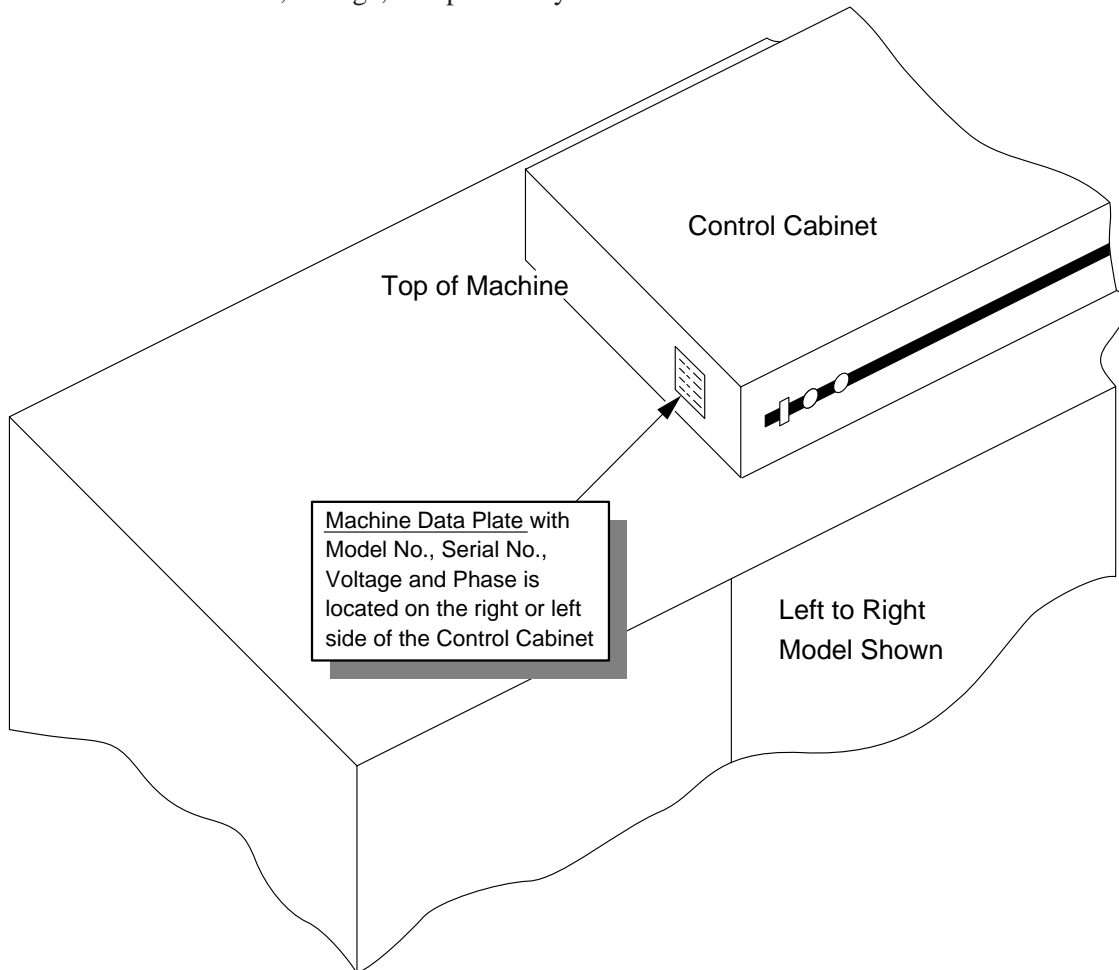

Revision History

Revision Date	Revised Pages	Serial Number Effectivity	Comments
03/10/00	All	89788	Reissue of manual and new replacement parts lists.
07/09/01	89	J1436	Added P/N 325838 overflow to Prewash Section.
07/09/01	44	J1436	Added P/N 113291 float switch to Wash and Rinse Section.
07/09/01	47	—	Changed P/N 110854 to 111019 to Econorinse Section.
07/09/01	79	—	Added 480V 95KW element to booster.
11/29/01	80	—	Revised bubble numbers on drawing
11/29/01	82	—	Changed P/N 105840 to 105841 on Steam Booster
11/29/01	84	—	Revised bubble numbers on drawings
01/03/02	40, 44, 47	J1534	Change vacuum breaker 1/2" 100500 to 113220
01/03/02	53	J1534	Change vacuum breaker 3/4" 104429 to 113222
01/03/02	79	J1534	Added GC 1/2" solenoid valve 113352 and repair kit 113392
4/30/02	40		Corrected float switch 110854 to 111019
05/22/02	40, 44, 47		Added 900836 Kit*Repair 1/4" & 1/2" Vacuum Breaker
05/22/02	53		Added 900837 Kit*Repair 3/4" Vacuum Breaker
2/5/03	39, 43, 47		Replaced P/N 108391 with 113622 thermometer.
2/5/03	67		Replaced impellers with new part numbers.
2/5/03	93, 97		Replaced Furnace (Siemens) overloads with Telemecanique (Square D) overloads.
7/23/03	40, 44, 47, 53		Revised plastic style vacuum breakers with bronze style.
8/6/04	53		Corrected curtain 112445 to 112446.
8/6/04	108		Remove buckets from tanks.

LIMITED WARRANTY

Champion Industries Inc. (herein referred to as Champion), P.O. Box 4149, Winston-Salem, North Carolina 27115, and P.O. Box 301, 2674 N. Service Road, Jordan Station, Canada, L0R 1S0, warrants machines, and parts, as set out below.

Warranty of Machines: Champion warrants all new machines of its manufacture bearing the name “Champion” and installed within the United States and Canada to be free from defects in material and workmanship for a period of one (1) year after the date of installation or fifteen (15) months after the date of shipment by Champion, whichever occurs first. [See below for special provisions relating to glasswashers.] The warranty registration card must be returned to Champion within ten (10) days after installation. If warranty card is not returned to Champion within such period, the warranty will expire after one year from the date of shipment.

Champion will not assume any responsibility for extra costs for installation in any area where there are jurisdictional problems with local trades or unions.

If a defect in workmanship or material is found to exist within the warranty period, Champion, at its election, will either repair or replace the defective machine or accept return of the machine for full credit; provided, however, as to glasswashers, Champion’s obligation with respect to labor associated with any repairs shall end (a) 120 days after shipment, or (b) 90 days after installation, whichever occurs first. In the event that Champion elects to repair, the labor and work to be performed in connection with the warranty shall be done during regular working hours by a Champion authorized service technician. Defective parts become the property of Champion. Use of replacement parts not authorized by Champion will relieve Champion of all further liability in connection with its warranty. In no event will Champion’s warranty obligation exceed Champion’s charge for the machine. The following are not covered by Champion’s warranty:

- a. Lighting of gas pilots or burners.
- b. Cleaning of gas lines.
- c. Replacement of fuses or resetting of overload breakers.
- d. Adjustment of thermostats.
- e. Adjustment of clutches.
- f. Opening or closing of utility supply valves or switching of electrical supply current.
- g. Cleaning of valves, strainers, screens, nozzles, or spray pipes.
- h. Performance of regular maintenance and cleaning as outlined in operator’s guide.
- i. Damages resulting from water conditions, accidents, alterations, improper use, abuse, tampering, improper installation, or failure to follow maintenance and operation procedures.
- j. Wear on Pulper cutter blocks, pulse vanes, and auger brush.

Examples of the defects not covered by warranty include, but are not limited to: (1) Damage to the exterior or interior finish as a result of the above, (2) Use with utility service other than that designated on the rating plate, (3) Improper connection to utility service, (4) Inadequate or excessive water pressure, (5) Corrosion from chemicals dispensed in excess of recommended concentrations, (6) Failure of electrical components due to connection of chemical dispensing equipment installed by others, (7) Leaks or damage resulting from such leaks caused by the installer, including those at machine table connections or by connection of chemical dispensing equipment installed by others, (8) Failure to comply with local building codes, (9) Damage caused by labor dispute.

Warranty of Parts: Champion warrants all new machine parts produced or authorized by Champion to be free from defects in material and workmanship for a period of 90 days from date of invoice. If any defect in material and workmanship is found to exist within the warranty period Champion will replace the defective part without charge.

DISCLAIMER OF WARRANTIES AND LIMITATIONS OF LIABILITY. CHAMPION’S WARRANTY IS ONLY TO THE EXTENT REFLECTED ABOVE. CHAMPION MAKES NO OTHER WARRANTIES, EXPRESS OR IMPLIED, INCLUDING, BUT NOT LIMITED, TO ANY WARRANTY OF MERCHANTABILITY, OR FITNESS OF PURPOSE. CHAMPION SHALL NOT BE LIABLE FOR INCIDENTAL OR CONSEQUENTIAL DAMAGES. THE REMEDIES SET OUT ABOVE ARE THE EXCLUSIVE REMEDIES FOR ANY DEFECTS FOUND TO EXIST IN CHAMPION DISHWASHING MACHINES AND CHAMPION PARTS, AND ALL OTHER REMEDIES ARE EXCLUDED, INCLUDING ANY LIABILITY FOR INCIDENTALS OR CONSEQUENTIAL DAMAGES.

Champion does not authorize any other person, including persons who deal in Champion dishwashing machines to change this warranty or create any other obligation in connection with Champion Dishwashing Machines.

CONTENTS

	Page
WARRANTY	ii
INTRODUCTION.....	1
GENERAL	2
Components and Features.....	2
Options.....	3
Modular Sections (Details and Dimensions).....	4
INSTALLATION.....	5
Unpacking.....	5
Locating	5
Assembling the Sections.....	5
Assembling the Conveyor Belt.....	6
Completing the Assembly	7
Installing the Optional Blower Dryer (Steam or Electric)	7
Plumbing Connections.....	8
Electrical Connections.....	8
Ventilation Connections.....	9
Machine Vent Damper Settings	9
Chemical Connections.....	9
INITIAL START UP	10
Baffles.....	10
Thermometers	10
Conveyor Shut-off Shelf	11
Conveyor Belt Drive Clutch Adjustment	11
Conveyor Belt Alignment.....	11
Energy Sentinel (Idle pump shut-off).....	11
OPERATION.....	12
Operation Steps.....	12
Curtain Placement.....	12
MAINTENANCE.....	15
Maintenance Schedule.....	15
Cleaning.....	15
Lubrication.....	16
Operation Checks	16
Deliming	17

	Page
TRUBLESHOOTING	18
BASIC SERVICE.....	21
Electrical Service.....	22
Fuse Blocks—120VAC Control Voltage.....	24
Motor Starter Overloads.....	24
Pump Timer and Final Rinse Timer.....	25
Electric Eye Energy Sentinel System	26
Automatic Fill/Low Water Heat Protection	28
Thermostat Locations and Adjustments	31
Motors	32
Mechanical Service.....	33
Pump Seal Replacement	33
Cross Flow Elbow Adjustment	34
Solenoid Valve Repair.....	34
REPLACEMENT PARTS	35
WIRING DIAGRAMS.....	105
ELECTRICAL SCHEMATICS	110

LIST OF FIGURES

Figure 1—Component Locator	2
Figure 2—Control Cabinet Chemical Connections	9
Figure 3—Baffle Locations.....	10
Figure 4—Conveyor Belt Drive Clutch	11
Figure 5—Conveyor Belt Alignment.....	11
Figure 6—Curtain Placement.....	12
Figure 7—Auto Fill Operation.....	12
Figure 8—Fresh Water Make-up	14
Figure 9—Fuse Blocks.....	24
Figure 10—Motor Starter Overloads	24
Figure 11—Pump Timer and Final Rinse Timer	25
Figure 12—Electric Eye Location	26
Figure 13—Sensor Mounting.....	26
Figure 14—Bypass Switch.....	27
Figure 15—Electric Eye Indicator Lights.....	27
Figure 16—Dual Float Switch Assembly	28
Figure 17—Dual Float Troubleshooting Diagram.....	30
Figure 18—Electric Tank Heat Thermostats	31
Figure 19—Electric Booster Thermostats	31

	Page
Figure 20—Booster High Limit.....	31
Figure 21—Motor Wiring Connections	32
Figure 22—Pump Seal Replacement	33
Figure 23—Cross Flow Elbow.....	34
Figure 24—Parker Solenoid Valve.....	34
Figure 25—Asco Solenoid Valve.....	34
Figure 26—Load Section	36
Figure 27—Prewash Section.....	38
Figure 28—Wash/Rinse Section	42
Figure 29—EconoRinse Section (Optional)	46
Figure 30—EconoRinse Pumped & Final Rinse Spray Arms.....	48
Figure 31—Unload Section	52
Figure 32—Drive Shaft Assembly	54
Figure 33—Conveyor Drive and Shut-off.....	56
Figure 34—Baffles and Back Flow Piping.....	58
Figure 35—Peg Belt.....	60
Figure 36—Peg Belt with Upper Rod.....	60
Figure 37—Flat Belt	62
Figure 38—Insulated Tray Belt and (Optional Silverware Belt).....	62
Figure 39—Stainless Steel Peg Belt	64
Figure 40—Pump Assembly	66
Figure 41—Electric Tank Heat	70
Figure 42—Steam Tank Heat.....	74
Figure 43—Steam Coils (Low Pressure/Standard Pressure)	76
Figure 44—Electric Booster	78
Figure 45—Steam Booster	80
Figure 46—Steam Booster 40° Rise	84
Figure 47—Steam Booster 40° Rise Low Pressure Only	88
Figure 48—Control Cabinet.....	92
Figure 49—Blower Dryer (Optional)	96
Figure 50—Control Panel, Electric Booster	98
Figure 51—Wiring Diagram 57KW Electric Booster	110
Figure 52—Wiring Diagram 63KW Electric Booster	111
Figure 53—Wiring Diagram 72KW Electric Booster	112
Figure 54—Wiring Diagram 81KW Electric Booster	113
Figure 55—Wiring Diagram Electric Tank Heat.....	114

ELECTRICAL SCHEMATICS

- B701669—Wiring Diagram (UCCW-2T, Steam/Electric)
(Beginning with Serial Number 89788)
- B701670—Wiring Diagram (UC-1T, Steam/Electric)
(Beginning with Serial Number 89788)
- B701512—Wiring Diagram (UCCW-3T, Steam/Electric)
(Beginning with Serial Number 89788)
- B701559—Wiring Diagram (UCCW-4T-WS, Steam/Electric)
(Beginning with Serial Number 89788)
- B701399—Wiring Diagram (UC Tank Heat/Electric)
(Beginning with Serial Number 89788)

APPENDIXES

- Appendix A**—UC-CW EconoRinse Section..... 103
- Appendix B**—Door Safety Switch and Magnet Mounting 104
- Appendix C**—Cross Flow Elbow Adjustments..... 105

INTRODUCTION

Welcome to **Champion...**

and thank you for allowing us to take care of your dishwashing needs.

This manual covers the basic Upright Conveyor Dishwasher model UC-CW.

Your machine was completely assembled, inspected, and thoroughly tested at our factory. Then it was disassembled and crated in sections for delivery to your installation site.

The reassembly and installation of your machine is performed by others. However, Champion can arrange for an Authorized Champion Service Agency to supervise the reassembly and installation. Electrical wiring and plumbing services, including final connections to the machine are supplied by others.

This manual contains:

- Warranty information
- Installation and operation procedures
- Maintenance instructions
- Troubleshooting guide
- Basic service information
- Replacement parts lists
- Wiring diagrams and electrical schematics

Complete and return your warranty registration card immediately after the installation of your machine.

All information, illustrations and specifications contained in this manual are based upon the latest product information available at the time of publication. **Champion** constantly improves its products and reserves the right to make changes at any time or to change specifications or design without notice and without incurring obligation.

For your protection, factory authorized parts should always be used for repairs.

Replacement parts may be ordered from your **Champion** authorized parts distributor or from your **Champion** authorized service agency.* When ordering parts, please supply the model number, serial number, voltage, and phase of your machine.

***Champion** can only ship parts to customers by VISA or MasterCard at list price.

GENERAL

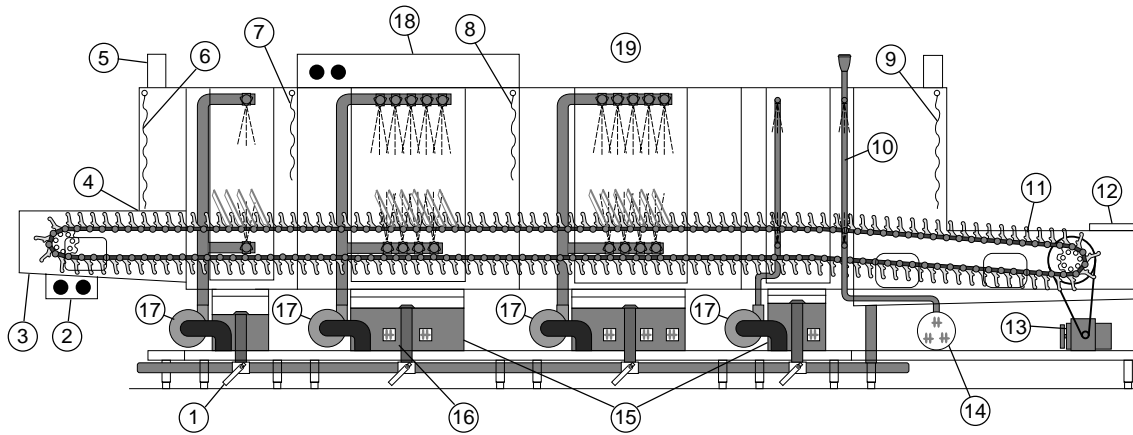

Figure 1
Left to Right Machine

Components and Features

Major Components

The major components of the UC-CW upright conveyor dishwashing machines are listed in Figure 1.

- | | |
|---|---|
| 1. Ball drain valve | 11. Peg belt (30" for UC-CW) |
| 2. Load end push button Start-Stop station | 12. Sliding conveyor shut-off shelf |
| 3. Load end Recirculating flushing nozzles | 13. Conveyor drive assembly |
| 4. Electric Eyes-Energy Sentinel (idle pump shut-off) | 14. Optional steam or electric booster |
| 5. Vent openings with 7" stainless steel stacks | 15. Steam coil/injectors or electric tank heat |
| 6. Load Section-Long Curtain | 16. Low water tank heat protection float switches |
| 7. Prewash Section-Short Curtain | 17. High Pressure recirculating pumps |
| 8. Wash Section-Short Curtain | 18. Top-mounted control cabinet |
| 9. Unload Section-Long Curtain | 19. Automatic Fill |
| 10. Final Rinse Piping | |

The UC-CW Upright Conveyor is a fully automatic dishwashing machine consisting of modular sections. Each section is available in a choice of lengths to satisfy your specific space and warewashing requirements. Champion's ability to custom build your machine to meet your application gives you the most powerful and versatile dishwashing machine on the market today.

Standard Features

- All models are constructed of heavy-gauge stainless steel including the panels, base, legs, and feet.
- All Models are available for either Right to Left or Left to Right operation.
- All models are high temperature (180°F final rinse) sanitizing machines.
- All Models have a single common water connection and a single common electrical connection. (A separate electrical connection is required for an optional electric booster or blower dryer).
- All models have chemical dispensing equipment connection provisions inside the control cabinet.
- Standard Voltages are available in: 208/60/3 240/60/3 460/60/3

For non-standard voltages please consult the factory.

Options

Your machine may be equipped with one or more of the following options:

- Auto fill with drain interlock
- Stainless steel back panel
- Conveyor Belts
 - Flat belt
 - Cup belt
 - Thermal tray belt
 - Silverware belt (with or without riser)
 - Belts with upper rods
 - or any combination of the above.
- Blower-dryer, steam or electric (Minimum 9 foot unload required)
- Bumper rail, machine mounted
- Cold water thermostat (for prewash section)
- Conveyor, variable speed, electric
- Doors, one piece lift-out for low ceiling installations
- Doors both sides of hood
- Energy sentinel and rinse saver gate switch system
- External scrap bucket on 4 foot prewash (Standard on 2 foot prewash)
- External scrap bucket on 4 foot wash, 6 and 8 foot wash and/or rinse
- Fused disconnect switch for machine and/or booster (unmounted)
- Insulated hoods, insulated panels
- Isolation switches for motors and/or electric tank heat
 - Motor pump, 2-HP optional in lieu of 1-HP on 2 foot prewash
 - Motor pump, 3-HP optional in lieu of 1-HP on 2 foot prewash
- Side safety rails
- Split unload section for shipping
- Start/Stop station, unload end
 - Steam pressure regulating valve (mounted)
 - Tray unloader (sample of tray and cart required)
 - Water pressure regulating valve (mounted) — Standard with built-in booster
- Champion steam boosters (built-in) Champion electric boosters (built-in)

40°F Rise through 70°F Rise	40°F Rise through 70°F Rise
-----------------------------	-----------------------------

Modular Sections (Details and Dimensions)

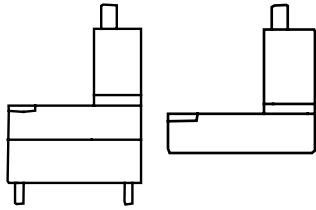

A-Load

The minimum available length of the load section is 3 feet and comes in a cantilevered design. The 4-8 foot load sections come in a base and leg design.

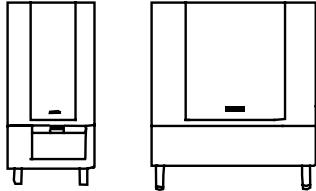

B-Prewash

Prewash sections are available in 2' and 4' lengths. The 2' section includes a standard external scrap basket and uses a 1-HP pump motor. The 4' prewash uses a 3-HP pump motor. The external scrap basket is optional on the 4' prewash.

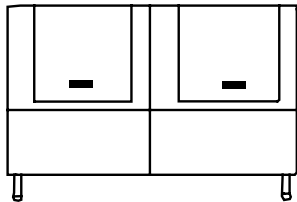

**C-Wash/Rinse
C3/C6**

The C3 module is a 3' section for either wash or rinse. The C6 is a combination of a 3' wash section and 3' power rinse section. Both sections have a 3-HP pump motor. External scrap baskets are optional.

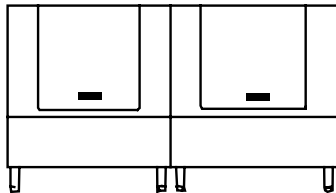

**C-Wash/Rinse
C4/C8**

The C4 wash or rinse section is a 4' module. The C8 is a combination of a 4' wash and a 4' power rinse section. Both sections have a 3-HP pump motor. The external scrap baskets are optional.

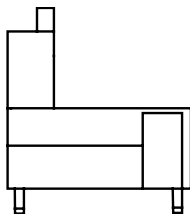

D-Unload

The unload section provides space for handling clean ware and is available in a minimum length of 4'. Longer sections are recommended for maximum drying or when an optional blower dryer assembly is used.

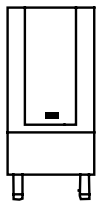

E-EconoRinse

The EconoRinse section is designed to capture and recirculate the final rinse water one additional time before it is used in the rest of the machine. The section measures 2' and uses a 1/4-HP pump motor.

INSTALLATION

Unpacking

- Immediately after unpacking your machine, check for any possible shipping damage. If any damage is found, save the packing materials, including the skids, and contact the carrier immediately.
- All the loose parts for your machine and the hardware needed for the assembly of the sections are contained in a box located on one of the skids.

Locating

- Before moving the sections into position, inspect the location site and be sure that the electrical, plumbing, and ventilation services are provided in the correct locations. Champion provides a Plumbing and Electrical Connections Drawing, (P&E), detailing these requirements. Compare the site connections with the machine to ensure that they will match when the machine is set in its permanent location.
- With each section on its skid, place it as close to its permanent position as possible.



CAUTION:

Each section has piping underneath the base. Lift the section carefully to avoid damaging the piping.

- Carefully lift each section, and remove the skid. Remove any tape and shipping brackets.
- Remove the wireway covers on the rear of each section and lay the wire bundles to the outside.
- Open all the doors. If you choose to remove the baffles for easier access to the section ends, be sure to note their location for correct reassembly later. (See Pg. 18, Fig. 3)
- Roll the conveyor belt toward the inside of the sections to make the section assembling easier.
- Move the center section (Wash/Rinse) to its final position and thread the feet in as far as possible.
- Move the other sections into position, leaving about 6 inches of separation between them. Thread all feet in as far as possible. **DO NOT BOLT THE SECTIONS TOGETHER AT THIS TIME.**

Assembling the Sections

- Check the height of each section and determine which section is the highest due to floor variations.
- Begin with the Wash/Rinse section and adjust its height. Keep in mind that the other sections will be leveled in relation to this section. Therefore, the height of the wash/rinse section must compensate for floor height variations.
- Level the wash/rinse section side to side and front to back in several places using a bubble level.
- Run a 1/2" bead of silicone sealant on the face of all sides of the hood gasket of the section end you are going to join.

Assembling the Sections (continued)

- Move the next section closer to the prepared end of the center section and adjust the feet of the second section so that the bolt holes around the hood and gasket align.
- Slide the connecting hoses and clamps on the drain pipes and cross-flow pipes. Do not tighten.
- Level the second section side to side and front to back in several places using a bubble level.
- Check the alignment of the conveyor tracks inside the machine, drains, cross-flows and wireways.
- Bolt the HOOD sections together FIRST, using the 5/16-18 X 3/4" bolts, lockwashers and nuts from the hardware kit.
- Bolt the base together NEXT, using the 1/2-13 X 1" bolts, lockwashers, and nuts from the hardware kit.
- Recheck the level of the assembled sections and relevel the second section if necessary.
- Adjust the hoses on the drain pipes and cross-flow pipes and tighten the clamps.
- Feed the wire bundles through the wireways and connect the wires.
 - Match corresponding numbers and connect them together.
 - Connect all white and #2 wires together. White and #2 wires are neutral wires.
- Connect the copper water lines at the rear of the sections. Be careful not to cross-thread the connectors.
- Connect the steam piping below the base (applicable to steam machines only).
- Install the baffles if you removed them prior to connecting the sections.
- Repeat the entire process for each section until the machine is completely assembled.

Assembling the Conveyor Belt

- Start at the unload end of the machine and pull the conveyor belt around the sprockets until approximately 1-1/2 feet of belt is exposed on the upper track of the machine.
- Pull a section of belt from the next section along the upper track into the unload end.
- Join the belt sections together by feeding a conveyor rod through the links, spacers, and rollers. Install a cotter pin on each end of the rod to secure the assembly.
- Continue this procedure until all the conveyor belt sections are joined.
- Adjust the conveyor belt tension at the load end by turning the adjusting bolts on the take-up assemblies. The take-up assemblies are located on either side of the load end conveyor shaft. Loosen the adjusting bolt locknuts.
- Turn each take-up adjusting bolt clockwise equally making sure that the conveyor shaft remains square with the end of the machine.
- Note the slack in the lower portion of the belt and be sure that the adjustment removes the slack.
- Check for the proper belt tension by lifting up the conveyor belt at the unload end. Proper tension has been reached when the belt can be lifted off the track a maximum of 1-1/2 to 2 inches. Tighten the adjusting bolt locknuts.
- RECHECK THE BELT TENSION IN 2-3 WEEKS AND READJUST AS NECESSARY.**
(See Initial Start Up #17, Pg. 11)

Completing the Assembly



CAUTION:

Overtightening the belt can result in damage to the belt and the conveyor belt drive assembly.

- Trim any excess silicone sealant that may have squeezed out from between the assembled sections. Apply a finish bead of silicone around the section joints.
- Install the vent stacks on the load and unload sections of the machine. Make sure the damper handles face toward the front of the machine.
- Install the curtains. Long curtains hang in hooks on each end of the machine. Short curtains hang in hooks on the inside of the machine. (See Fig. 6, Pg. 20)
- Check each tank and the interior of the machine and remove any foreign material.
- Install the screen supports, scrap screens, and access panels.

Installing the Optional Blower Dryer (Steam or Electric)

The blower dryer is available in either electric or steam and is shipped on a separate skid along with the machine. The vent cowl and mounting hardware for the blower dryer are shipped in the box containing the dishwashing machine parts and hardware.

- Remove the blower dryer from the skid and install the unit on the top of the unload section of the machine.
- Bolt the blower dryer in place using the 5/16-18 X 3/4" bolts, flat washers, and lock washers from the hardware kit.
- Fasten the vent cowl on the discharge end of the blower dryer using the 1/4-20 plain nuts, flat washers, and lock washers from the hardware kit.
- Connect the electrical wiring by moving the prewired flexible conduit into position with the 3" X 5" junction box located on the side of the blower dryer.
 - Secure the conduit to the junction box.
 - Match the corresponding wire numbers in the junction box and the conduit and connect them together.
 - Connect all white and #2 wires together. White and #2 wires are neutral wires.

PLUMBING CONNECTIONS



CAUTION:

Plumbing connections must comply with local sanitary and plumbing codes.

- Connect all supply connections for water, steam, and drain lines at the points indicated on the P&E Connections Drawing.
- Tags are wired to the machine piping to indicate these connection points.
- Shut-off valves should be installed in all supply lines to allow for servicing of the machine.
- Pressure Reducing Valves, supplied by Champion or others, should be installed on the incoming water supply lines and the incoming steam supply lines as close to the machine as possible.
- Water Hammer Arrestor meeting ASSE-1010 standard or equivalent, should be installed in the common water supply line at the service connection.
- HOT WATER**
 3/4" NPT 140°F. Flow pressure 20-22 PSI (For machine with built-in 40° rise steam/electric booster)
 3/4" NPT 110°F. Flow pressure 20-22 PSI (For machine with built-in 70° rise steam/electric booster)
 3/4" NPT 180°F. Flow pressure 20-22 PSI (For machine without built-in booster)
- COLD WATER**
 1/2" NPT 65°F tempering cold water connection. (For prewash with cold water thermostat)
- STEAM**
 Refer to the P&E Connections Drawing or consult the factory.
 Blower Dryer- 3/4" NPT @ 85lbs/hr consumption at 15 psi flow pressure.
- DRAIN**
 1-1/2" NPT machine connection 3/4" NPT booster relief to an open drain.

ELECTRICAL CONNECTIONS



WARNING:

Electrical and grounding connections must comply with the National Electrical Code and/or Local Electrical Codes.



WARNING:

When working on the dishwasher, disconnect the electric service and place a tag at the disconnect switch to indicate work is being done on that circuit.

- A qualified electrician must compare the electrical power supply with the machine electrical specifications stamped on the MACHINE ELECTRICAL CONNECTION PLATE located inside the control cabinet before connecting to the incoming service at a fused disconnect switch.
- Motor rotation was set at the factory. Correct rotation for the drive motor is indicated by a direction arrow decal on the drive sprocket. The sprocket can be found at the unload end of the machine behind a stainless steel panel.
- Correct rotation for the pump motors are clockwise when viewed from the rear of the pump motor. This is also identified by a direction arrow decal on the pump motor.
- Reversing motor rotation must be performed in the Control Cabinet. Reverse the wires L1 and L2 on the disconnect switch side of the main electrical connection terminal block.

- A knock-out plug is provided at the rear of the control cabinet for electrical service connections.
- Electric boosters and Electric blower dryers each require a separate electric connection.
- A fused disconnect switch or circuit breaker (supplied by others) is required to protect each power supply circuit.
- MOTOR STARTER OVERLOAD levers must be checked to ensure they are in the ON position.

VENTILATION CONNECTIONS

- Stainless steel watertight ducting should be installed above the machine.
- Duct connections must be made to the inside of the machine vent stacks.
- Exhaust air must not be vented into a wall, ceiling, or concealed space of the building.
- Machine Ventilation Requirements:

MODEL	UC-CW	UC-CW-WS
LOAD END	400 CFM at 1/4" S.P.	300 CFM at 1/4" S.P.
UNLOAD END*	900 CFM at 1/4" S.P.	800 CFM at 1/4" S.P.

*With an optional Blower dryer, increase room ventilation by 600 CFM at 1/4" S.P. at the unload end.

- A Minimum of six (6) air changes per hour (provided by building ventilation system) is recommended for the warewashing area.

MACHINE VENT DAMPER SETTINGS

- Each vent stack is equipped with an adjustable damper.
- Proper adjustment of the dampers collects moist vapor as it exits the machine. This prevents moisture from escaping into the wash room.



CAUTION:

Opening the dampers too much will remove heat from the machine interior and may make it difficult to maintain the proper wash/rinse tank temperatures. Set the dampers to best meet your particular installation. Figure A and B show the minimum and maximum vent settings.

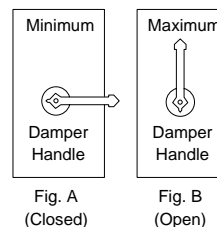

CHEMICAL CONNECTIONS

- Labeled connection points are provided inside the control cabinet for chemical dispensing equipment.

These connection points include:

- A 120VAC detergent signal between Wire #10 and Common.
- A 120VAC rinse aid signal between Wire #12 and Common.
- Removable black plugs are located at various points on the wash tank for the mounting of a conductivity cell.
- A removable plug on the final rinse piping is provided as a rinse aid injection point.

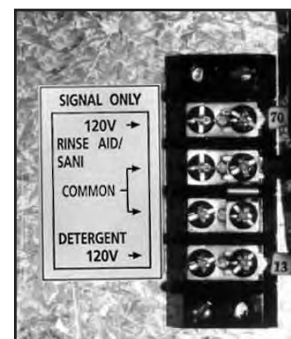

Figure 2
Control Cabinet
Chemical Connections

INITIAL START UP



NOTE:

Perform the following checks and adjustments before placing the machine into service.

1. Check the interior of the machine and remove any foreign material.
2. Check the exterior of the machine — make sure that the conveyor belt is free of tape and foreign material.

Baffles - Tank baffles redirect the flow of water from the spray arm systems back into the tanks. This prevents water loss and keeps the wash, rinse, and final rinse water in the proper tank.

3. Check the baffles — make sure that they are installed and positioned correctly.

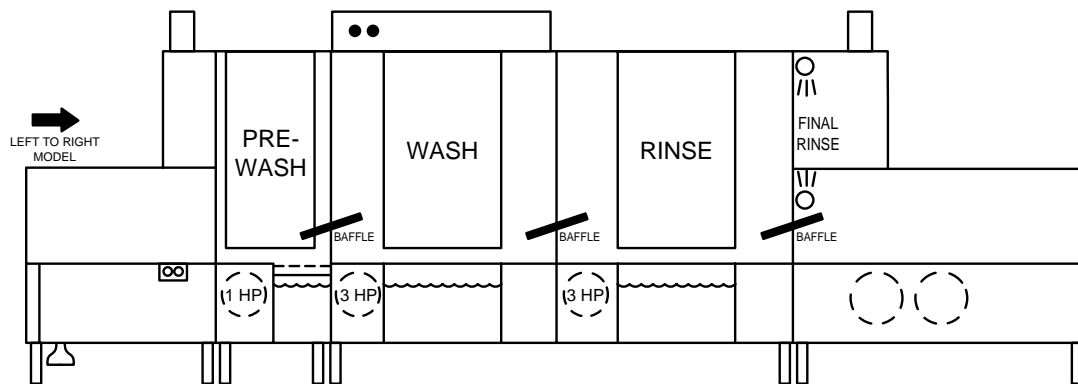

Figure 3 Baffles

4. Close the tank drain valves along the lower front of the machine.
5. Open the water supply valves. Check for leaks and take corrective action as required.
6. Open the steam supply valves (if applicable). Check for leaks and take corrective action if required.
 - Machine steam valves
 - Blower Dryer (if applicable) steam valves
7. Turn the main power on at the breaker panel or fused disconnect switch.
 - Machine main power
 - Electric booster main power (if applicable)
8. Flip the Power Switch on the front of the Control Cabinet to the “ON” position.
 - The Red power on light will illuminate.
 - The machine will begin to fill with water.
9. Allow the machine to completely fill with water.
 - The water will shut off automatically.
10. Check for leaks and take corrective action if required.
11. Monitor the tank thermometers for the proper temperature reading.
 - Allow sufficient time for the tank heat to reach operating temperature.
 - Refer to the chart below.

TANK	Prewash	Wash	Power Rinse
TEMPERATURE °F	120° - 140°	150° - 170°	160° - 180°

12. Move the conveyor shut-off shelf located at the end of the unload section toward the machine.
 - This resets the automatic conveyor stop system.
 - When an object on the conveyor contacts the shut-off shelf, the conveyor stops.
13. Press the GREEN start button on the front of the control cabinet.
14. Check the direction of rotation of the conveyor belt by observing the direction arrow decal on the large conveyor drive sprocket. The sprocket is located on the side of the unload section.
15. If rotation direction is incorrect, reverse wires L1 and L2 on the disconnect switch side of the main electrical connection terminal block located inside the control cabinet.
16. Adjust the conveyor belt drive clutch. The clutch is located on the large conveyor drive sprocket on the side of the unload section. Refer to Fig. 4.

To adjust:

- a. Tighten the clutch nut on the center of the drive sprocket until the conveyor begins to move.
- b. Have a person of average build (about 185 lbs.) hold the belt with both hands and pull against the direction of travel.
- c. Continue tightening the clutch nut until maximum effort against the direction of travel is required to stop the belt.



NOTE:

Final adjustment of the clutch depends upon the overall length of the conveyor belt and the maximum weight that may be placed on the conveyor belt during normal operation.

CHECK AND ADJUST CLUTCH MONTHLY.

17. Check the alignment of the conveyor belt. Adjust the take-up assemblies so that Conveyor Rollers (A) track evenly on Conveyor Sprockets (B). See Fig. 5.
18. Check the Energy Sentinel (idle pump shut-off) by placing a tray or dish on the moving conveyor belt.
 - The pumps will start as the object enters the tunnel of the machine.
 - The optional econorinse pump starts with the final rinse.
 - Check pump motor rotation, CW when viewed from the rear of motor.
19. Check the final rinse temperature as the object enters the final rinse area.
 - The Final rinse temperature must be 180-195°F.
 - Adjust the temperature of the incoming water supply if necessary.
 - Adjust the booster thermostat setting if necessary.
20. Check the Final rinse water pressure as the object enters the final rinse area.
 - The final rinse pressure must be 20-22 PSI.
 - Adjust the Pressure Reducing Valve setting if necessary.
21. Check that the pumps and final rinse shut-off before the object reaches the conveyor shut-off shelf.
22. Check that the conveyor belt stops when the object pushes the conveyor shut-off shelf.
23. Move the shut-off shelf toward the tunnel of the machine. The conveyor belt will start moving again.
24. Push the RED stop button. The conveyor belt will stop moving.
25. Flip the power switch on the control cabinet to OFF. The red power light will go out.
26. Open all the drain valves and check that the house drains can handle the flow.
27. Remove any protective film from the stainless steel and install the side panels and chain guard.

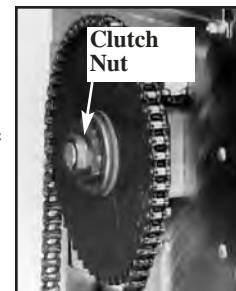

Figure 4 - Conveyor Belt Drive Clutch

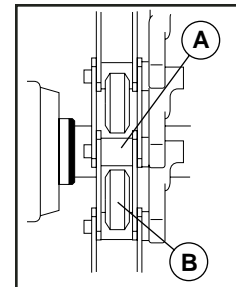

Figure 5 - Conveyor Belt Alignment

OPERATION

Operation Steps

Perform the following steps to place your machine in operation. Refer to Fig. 6.

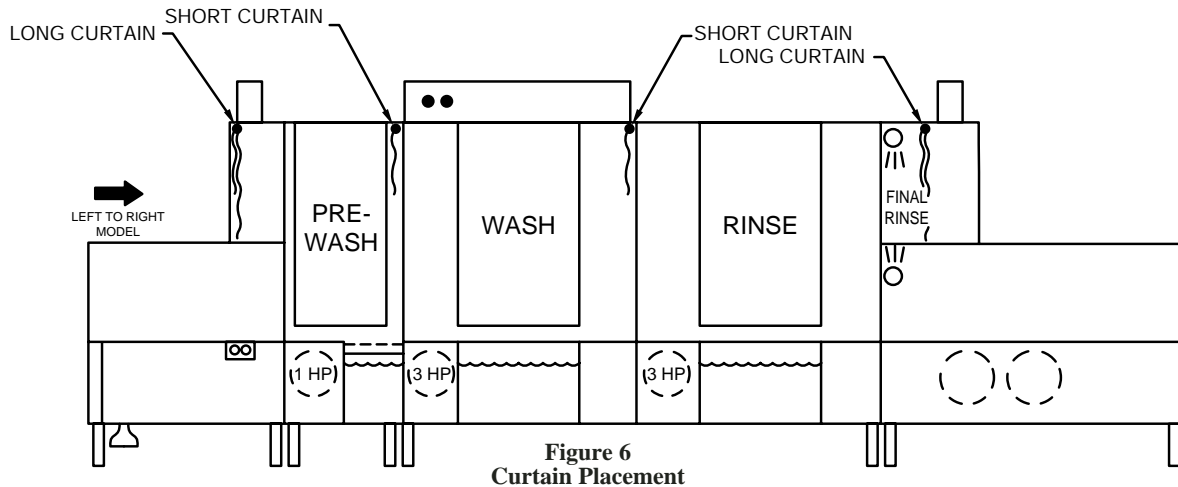

Figure 6
Curtain Placement

1. Check the curtains for correct placement in the machine.
 - Be sure the short flaps of the Long Curtains face the load end of the machine.
2. Check the spray pipes.
 - Be sure the spray pipe gasket is installed on the end of spray pipe before installing.
 - Spray pipes are installed by inserting the pipe into the coupler and turning 1/4 turn clockwise.
3. Check the scrap screens.
 - Install any scrap basket covers.
4. Check that the conveyor shut-off shelf is pushed toward the machine tunnel.
5. Close the drain valves, located under the base of each tank.
 - When the drain handle is horizontal, the valve is open.
 - When the valve handle is vertical, the valve is closed
6. Check the detergent and rinse aid supplies (supplied by others).
7. Turn on the detergent and rinse-aid dispensers (supplied by others).
8. Close all the doors making sure the door safety switches are activated.
9. Flip the Power Switch on the front of the control cabinet to "ON."
 - The RED power light will illuminate.
 - The machine will automatically fill with water.
 - When the tanks are full, the water will stop and the tank heat will come on.
10. Fig. 7 illustrates the automatic fill operation.

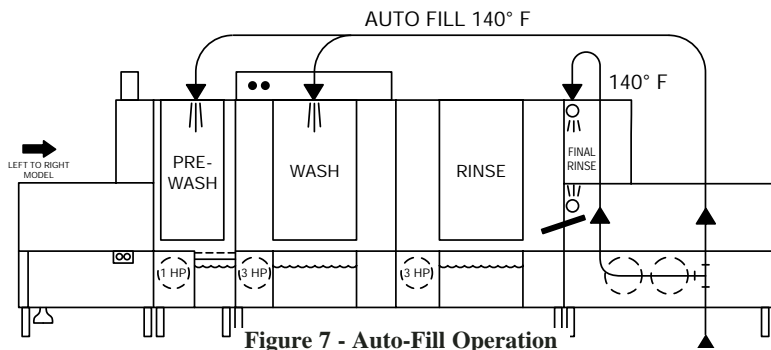

Figure 7 - Auto-Fill Operation

OPERATION (continued)

11. Wait for the tanks to reach operating temperature.
12. Monitor the temperature gauges located below the doors. Refer to the chart below for the proper temperature readings.

TANK	Prewash	Wash	Power Rinse
TEMPERATURE °F	120° - 140°	150° - 170°	160° - 180°

**WARNING:**

This machine contains moving conveyor parts

- *Use caution when working near conveyor.*
- *Disconnect power to machine when cleaning or servicing.*

13. Press the GREEN start button on the front of the control cabinet or the green start button on the START/STOP station located at the load end of the machine.
 - The conveyor belt will begin to move. (Pumps do not run at this time)
 - If the conveyor belt does not move, recheck the position of the conveyor shut-off shelf — and,
 - Place the conveyor shut-off shelf in the operating position.
14. Scrap and flush the ware before loading it on the conveyor belt.
For the best washing results:
 - Stagger objects across the conveyor belt.
 - Cups, glasses, and silverware are best washed in racks. Distribute silverware evenly in a single layer in the bottom of a flat rack.

As an object enters the tunnel of the load end, it will block the electric eyes. This starts the pumps.

 - An Automatic timer controls the pump run time.
 - The final rinse, also controlled by an automatic timer, will start as an object moves near the final rinse area. The optional econorinse pump starts with the final rinse.
15. Check the final rinse temperature as the final rinse begins.
 - The temperature gauge is located on the top of the machine in the final rinse piping.
 - The correct reading must be between 180°-195°F.
16. Check the final rinse flow pressure during the final rinse.
 - The pressure gauge is located on the lower panel of the unload section.
 - The correct flow pressure must be between 20-22 PSI. The pressure gauge may read more than 22 PSI before and after the final rinse cycle. This is a normal condition.

As an object exits the tunnel of the machine the automatic timers will:

 - Shut off the final rinse and the pumps before the object reaches the conveyor shut-off shelf.
 - If the conveyor belt is loaded with a number of objects, the final rinse and the pumps will continue to run until an object pushes the conveyor shut-off shelf into the OFF position.
 - The conveyor belt and the final rinse will stop.
 - The automatic timers will stop.

OPERATION (continued)

17. Push the conveyor shut-off shelf towards the tunnel of the machine to return it to its operating position. This will:
 - Restart the conveyor belt and the final rinse.
 - The automatic timers will restart where they left off. This ensures that any objects remaining on the conveyor belt will be completely washed and sanitized by the final rinse.
18. Press the RED stop button on the control cabinet or the START/STOP station on the load section.
 - The conveyor will stop.
 - The final rinse will stop.
 - The pumps will stop.
19. Press the GREEN start button on the control cabinet or the START/STOP station on the load end. The conveyor, the final rinse, and the pumps will start again.
 - The machine will continue to run until the automatic timers complete their timed cycles or an object pushes the conveyor shut-off shelf to the "OFF" position.

Fresh make-up water is added to the tanks as required automatically.

- A majority of the fresh water comes from the Final Rinse.
- Additional make-up water is supplied by valves activated by float switches located in each tank.

Refer to Fig. 8 below for the typical fresh water make-up supply.

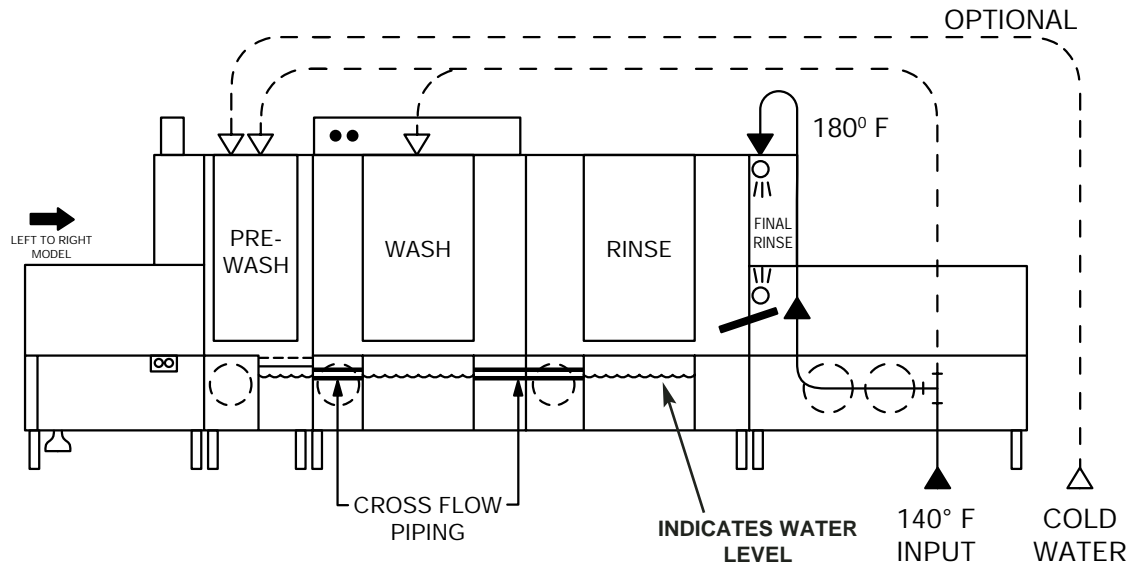

Figure 8
Fresh Water Make-up

MAINTENANCE

Regularly scheduled maintenance will increase the efficiency and life of your machine. A well maintained machine gives better washing results and service. Undoubtedly, the time that you invest in daily maintenance now, will pay-off in the future.

Cleaning your machine is the best maintenance that you can provide. Components that are not regularly flushed and cleaned do not perform well.

The Maintenance Intervals shown in the following schedules are the minimum requirements necessary for the proper performance of your machine. Shorten the maintenance intervals whenever your machine is faced with abnormal working conditions, hard water, or multiple shift operations.

Maintenance Schedule

CLEANING

- **Every 2 Hours or After Each Meal Period**

1. When the last object on the conveyor belt exits the tunnel of the machine, the pumps will shut off automatically.
2. Press the RED stop button on the control cabinet or the START/STOP station on the load section.
 - The conveyor will stop.
3. Flip the Power switch on the front of the control cabinet to “OFF.”
 - The Red power on light will go out.
4. Open the doors.
5. Open the drain valves and allow the machine to drain.
 - The valve is open when the handle is placed in the horizontal position.
6. Remove the scrap screens and scrap baskets.
 - Back flush the screens and baskets and reinstall in the machine.
 - Check spray nozzles.
7. Close the drain valves and doors.
8. Flip the Power Switch on the front of the control cabinet to the “ON” position.
 - The RED power light will illuminate.
 - The machine will automatically refill with water.

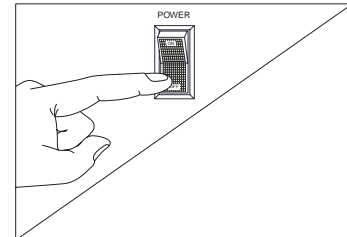

- **Every 8 Hours or at the End of the Day**

1. Press the RED stop button on the control cabinet or the START/STOP station on the load section.
2. Flip the Power Switch on the front of the control cabinet to the “OFF” position.
3. Remove all the scrap screens and baskets.
4. Back flush the scrap screens and baskets until clean.

DO NOT STRIKE SCREENS OR BASKETS AGAINST SOLID OBJECTS TO CLEAN.

5. Open the drain valves and allow the tanks to drain.

CLEANING (continued)



CAUTION:

Do Not Leave Water in the Tanks Overnight.

6. Flush the inside of the load and unload sections with clean water.
7. Flush the inside of the tanks with clean water and wipe away any residue.
8. Flush the pump suction strainers, the tank drain screens, and the drain screen on the unload section.
9. Flush the inside of the machine again making sure all drains are clean and free flowing.
10. Remove the spray pipes by turning 1/4 turn counterclockwise.
 - Remove the end cap from each spray pipe
 - Flush the pipe and nozzles until clean.

Do not strike the spray pipes on solid objects to clean.

 - Replace the end caps
 - Make sure that the rubber gaskets are in place on the end of the spray pipe.
11. Reinstall the spray pipes by turning 1/4 turn clockwise.
12. Clean the final rinse pipe nozzles of any mineral deposits.
(A straightened paper clip works very well as a cleaning tool).
13. Remove and clean the curtains. Allow the curtains to air dry.
14. Reassemble the machine.
15. Leave the doors open to allow the interior of the machine to air dry.
16. Clean the exterior of the machine. **DO NOT HOSE DOWN WITH WATER.**
17. Report any unusual conditions to your supervisor.

Lubrication

• Every 3 months

1. Check the oil level in the conveyor drive gear reducer. Refill with SAE 90 gearcase oil.
2. Add grease to the conveyor shaft bearings; usually one pump from a grease gun using a general purpose grease.
3. Motor bearings do not require lubrication.
4. Apply a thin coat of grease to the conveyor drive sprocket chain. Avoid getting grease on the drive clutch; wipe any excess grease off immediately.

Operation Checks

• Daily

1. Check temperature gauges for proper readings.
2. Check pressure gauge for proper reading.
3. Check pumps for leaks around motor shaft.
4. Inspect general condition of machine.
5. Check chemical supplies (supplied by others) and refill as necessary.

Operation Checks

• Weekly

1. Inspect all water lines for leaks and tighten at joints if required.
2. Clean all detergent residue from the exterior of the machine.
3. Check the drains for leaks.
4. Clean accumulated mineral deposits from the tank heating elements or steam coils.
5. Remove and inspect each spray pipe for blockage and clean if required.
6. Clean the final rinse nozzles of accumulated mineral deposits.
7. Check the float switches located in each tank to ensure they move freely.
8. Inspect the conveyor belt for broken or worn parts.
9. Inspect the electric eyes and clean the lenses.
10. Inspect the conveyor shut-off shelf for freedom of travel.
11. Check the conveyor drive clutch adjustment.

Deliming

Mineral deposits, which are frequently referred to as lime because of their white color, accumulate in the interior of the machine over time. The amount of lime build-up depends on the mineral content of your water supply. Machines in regions of the country that have hard water (high mineral content) will require more frequent deliming than in regions with soft water (low mineral content).



NOTE:

Consult your chemical supplier for an appropriate deliming solution.



WARNING:

Deliming solutions or other acids must not come in contact with household bleach (sodium hypochlorite) or any chemicals containing chlorine, iodine, bromine, or fluorine. Mixing will cause hazardous gases to form. Skin contact with deliming solutions can cause severe irritation and possible chemical burns. Consult your chemical supplier for specific safety precautions.

• Weekly or as required

1. Inspect the interior of the machine for lime deposits.
2. Follow the chemical supplier's recommendations for the deliming solution.
3. Thoroughly flush the interior of the machine when the deliming is complete.

TROUBLESHOOTING

On occasion your machine may not operate as expected.

Use the checklist below before you decide that a mechanical or electrical failure has occurred.

Checklist

1. Are the main disconnect switches, breakers, or motor overloads turned ON?
2. Are the main water and steam supplies turned ON?
3. Are the drain valves closed?
4. Are the spray pipes and rinse nozzles clean?
5. Are the spray pipes in the proper locations?
6. Are the pump intakes clean?
7. Are the scrap screens clean and in place?
8. Are the thermostats correctly adjusted?
9. Are the high limit temperature thermostats reset?
10. Are the doors fully closed?
11. Are the conveyor shut-off and drive assemblies in operating condition?
12. Are the chemical supplies adequately filled?

If a problem still exists after verifying the checklist, refer to the following Troubleshooting Chart.

CONDITION	CAUSE	SOLUTION
Conveyor will not run	Door not closed	Make sure doors are fully closed
	Door safety switch faulty	Contact your service agency
	Start switch faulty	Contact your service agency
	Main switch OFF	Check disconnect
	Control panel power switch OFF.....	Flip switch ON
	Conveyor shut-off shelf operated.....	Move shelf toward tunnel of machine
	Motor overload protector tripped.....	Reset overload in control cabinet
	Green start button not pressed	Press green start button
Conveyor runs but Prewash, Wash, and Power Rinse pump will not run	Nothing on the conveyor.....	Load the conveyor
	Electric eyes (Idle pump shut-off) system faulty	Clean the electric eye lenses
		Flip the Automatic/Manual switch in the control cabinet to MANUAL and Contact your service agency
Optional EconoRinse pump will not run	Final Rinse Timer not calling for operation	Refer to EconoRinse section operation Appendix A (Page 104)
	Motor overload tripped	Reset overload in control cabinet
	Defective motor.....	Contact your service agency

TROUBLESHOOTING

CONDITION	CAUSE	SOLUTION
A single pump will not run	Motor overload tripped Defective motor.....	Reset overload in control cabinet Contact your service agency
Low or no water	Main water supply is turned off..... Drain valves are open..... Doors are not fully closed..... Faulty fill valve Stuck or defective float switch..... Cross-flow piping misadjusted/ clogged Clogged strainer at supply connection PRV misadjusted or defective.....	Turn on house water supply Close all drain valves Close doors Contact your service agency Free float /Contact service agency Adjust cross-flow setting/Clean piping Clean strainer screen Readjust pressure setting or replace PRV
Continuous water filling	Stuck or defective float switch..... Fill valve will not close..... Drain valves open.....	Free float/Contact service agency Clean valve,repair or replace valve Close drain valves
Wash/Power Rinse tank temperature is low when machine is operating	Incoming water temperature at machine is too low Defective thermometer..... Defective thermostat Defective electric heater element..... Low steam pressure or volume Defective steam trap..... Defective solenoid valve.....	Raise incoming temperature 140°F minimum for 40° rise booster 110°F minimum for 70° rise booster 180° F minimum without booster Check or replace Readjust setting or replace Check or replace Check steam supply pressure Check or replace Check or replace
Prewash tank temperature is too high (Optional Cold Water thermostat Only)	Incoming cold water temperature too high..... Defective cold water thermostat	Lower incoming water temperature to maximum of 65°F Check or replace
Insufficient pumped spray pressure	Clogged pump intake screen Clogged spray pipe..... Scrap screen full..... Low water level in tank Pump motor rotation incorrect..... Defective pump seal.....	Clean Clean Must be kept clean and in place Check drain valves Reverse wires L1 and L2 in control cabinet Contact service agency
Insufficient final rinse or no final rinse	Faulty pressure reducing valve (PRV) Improper setting on PRV Clogged rinse nozzle or pipe Improper water line size..... Clogged “Y” strainer.....	Clean or replace Set Flow pressure to 20-22 PSI Clean Installer must change to proper size Clean or replace

TROUBLESHOOTING

CONDITION	CAUSE	SOLUTION	
Low final rinse temperature	Low incoming water temperature	Raise incoming water temperature 140°F for 40° rise booster 110°F for 70° rise booster 180°F without booster	
	Defective thermometer.....	Check or replace	
	Defective thermostat	Recalibrate or replace	
	High limit thermostat tripped.....	Reset or replace	
	Low steam pressure.....	Check steam supply pressure	
Poor washing results	Detergent dispenser not operating	Contact the chemical supplier	
	Detergent supplied not strong enough	Contact the chemical supplier	
	Wash water temperature too low	See Condition “Wash/Rinse tank water temperature too low”	
	Spray pipes clogged	Clean	
	Improperly scrapped dishes	Check scrapping procedures	
	Ware improperly loaded on conveyor	Stagger ware on belt	
	Maintenance not performed as required	See Maintenance Schedule	
	Electric elements/steam coils have lime build-up	Clean and delime Contact the chemical supplier	
	Poor drying results	Excessive humidity in warewashing area	Check vent dampers and exhaust fans
		Improperly stacked dishes after washing	Check unloading procedures
Insufficient rinse-aid		Contact chemical supplier	
Final rinse temperature too low		See Condition “Final Rinse temperature too low”	

BASIC SERVICE

To the Reader—

This section is intended for qualified service and maintenance personnel only.

DO NOT ATTEMPT ADJUSTMENTS OR REPAIRS IF YOU ARE NOT QUALIFIED.

A qualified servicer is someone who has:

1. A thorough knowledge of all safety precautions and procedures.
2. A thorough knowledge of basic electricity and electrical troubleshooting methods.
3. A thorough knowledge of dishwashing machine mechanics and operation.



WARNING:

Serious personal injury may result

if persons lacking the proper training or experience attempt to adjust or repair a Champion Dishwashing Machine.

—In addition—

Serious or permanent damage to the machine may result

if persons lacking the proper training or experience attempt to adjust or repair a Champion Dishwashing Machine.



WARNING:

This machine contains moving conveyor parts

- Use caution when working near conveyor.

- Disconnect power to machine when cleaning or servicing.

To the Qualified Servicer—

The following service information explains procedures for adjusting and repairing some of the major components on the UC-CW dishwashers. In addition, you will find some basic guidelines for troubleshooting and evaluating problems.

Champion dishwashers contain some unique design features that may be unfamiliar to you. We have included explanations about a number of these features.

This Basic Service section does not cover all possible repair procedures. However, if you require additional service support, you can call:

Champion National Service

1-800-858-4477

Please have the Model and Serial Number of the machine ready when you call.

Note:**Champion offers a variety of options for the Upright Conveyor dishwasher.**

It is extremely important that you identify the options installed on the machine BEFORE you begin repairs.

The basic operation of the upright conveyor is the same for all models. If you are not completely familiar with the design and operation of your machine, please read all the information contained in this manual before attempting any repairs. What appears to be a serious problem at first, may be corrected with a simple maintenance or operation check.

ELECTRICAL SERVICE

Power Requirements: All models require 3 Phase power.
Standard voltages are available in 208/60/3 240/60/3 460/60/3
Non-standard voltages are available—Consult the factory.

Service Connections: The main power connection is made at a single point in the Control Cabinet. Optional Electric Boosters have a separate service connection.
Optional Electric Blower dryers have a separate service connection.

Line Voltage:

Three phase line voltage is supplied to:	Pump motors Drive Motor Optional Blower Dryer motor Electric tank heater elements Optional Booster tank heater elements
Single phase line voltage is supplied to:	Control Transformer — (In control cabinet) [Step-down Line Voltage: 120VAC]

Control Voltage: 120VAC is supplied by the secondary of the control transformer to:

Control cabinet switches Remote pushbutton stations The Electric Eye circuit input Pump & Final Rinse Timers Solenoid Valves Thermostats Contactors Motor starter overloads Hold-in Relay 24VAC Control Transformer [Step-down 120VAC:24VAC]
--

Electrical Service (Continued)

Control Voltage (24VAC)

24VAC control voltage
is supplied to:

Door Safety Switches
Float switches
Conveyor switch
Control Relays (See Control Cabinet/Schematic)

Troubleshooting

Schematics

Champion places an electrical schematic in the control cabinet of every machine before it is shipped. Schematics are included at the back of this manual as well. Be aware that these schematics include options that may not apply to your machine. Options are enclosed in dashed lines with the words (IF USED) next to them on the schematic. Disregard any options that appear on the schematics which are not a part of your machine.

Tools

All electrical repairs can be made with:

- Standard set of hand tools
- Volt/Ohm Meter (VOM)
- Clip-on AC current tester

Circuit Tests

Use a clip-on AC current tester to check the 3-phase motors and electric heaters.
Use a VOM to test the 120VAC and the 24VAC control circuits and their associated components.



NOTE:

Do not use chassis ground when performing voltage checks.

Doing so will result in false and inaccurate readings.

PERFORM VOLTAGE CHECKS BY READING FROM THE HOT SIDE OF THE 120VAC LINE AND ANY WHITE WIRE. (Wire #2 on the electrical schematic).



WARNING:

USE EXTREME CAUTION when performing tests on energized circuits.



WARNING:

When repairing a circuit, disconnect the power at the main service disconnect switch and place a tag at the disconnect switch to indicate that work is being performed on the circuit.

ELECTRICAL SERVICE (Continued)

Repairs

Fuse Blocks—120VAC Control Voltage

Two fuse blocks, located in the center rear of the main control cabinet protect the main control transformer. Each fuse block holds a 5 AMP fuse. The fuses are marked 1FU and 2FU on the electrical schematic.



Figure 9
Fuse Blocks

To Replace the fuse:

- Disconnect power to the machine at the main service switch.
- Flip the tab on the top of the fuse block to open the block.
- Remove the 5 AMP fuse and replace with another 5 AMP fuse.
- Close the fuse block and turn the main power on.
- If the fuse blows again, DO NOT INCREASE THE FUSE SIZE.
- DETERMINE THE CAUSE OF THE OVERLOAD.

Fig. 9 shows the fuse block opened and the fuse exposed.

Motor Starter Overloads

Combination motor starters/Trip overloads are located to the left of the fuse blocks inside the control cabinet. Each 3-phase motor has one Motor Starter overload to protect it from Line Voltage electrical overloads. In addition, an auxiliary set of switch contacts is built into the motor starter overload. The switch contacts disconnect 120VAC power to the Motor Contactor Coils in the event of an overload condition. Refer to Fig. 10.

Note the Switch Lever on the Overload:

- If the switch lever is off with the “0” showing then the overload has tripped on an overload.

To Reset the Motor Starter Overload:

- Flip the overload switch to the On position.
- Run the dishwasher and test the AMP draw of the motor in question. If the motor checks okay then there may be a wiring problem or the overload may be defective.

To Replace a Motor Starter Overload:

- Disconnect the wires to the overload.
- Release the mounting catch on the front side of the overload, push forward and lift out.
- Snap the new overload into place and reconnect the wires.

To adjust the overload setting:

- The screwdriver in Fig. 10 is positioned to adjust the motor overload AMP setting.
- Read the FLA motor amps on the Motor Nameplate.
- Turn the setting to match the Nameplate.



Figure 10
Motor Starter Overload

Pump Timer and Final Rinse Timer

The timers have the following user-defined settings:

1. Adjustable time range
2. Timer knob setting
3. 50 Hz or 60 Hz setting
4. Indicator light (“ON” when timer is counting)

The Pump Timer is an OFF DELAY timer.

The Final Rinse Timer is an ON DELAY timer.

Each timer is clearly marked with a tag noting the time set by the factory.

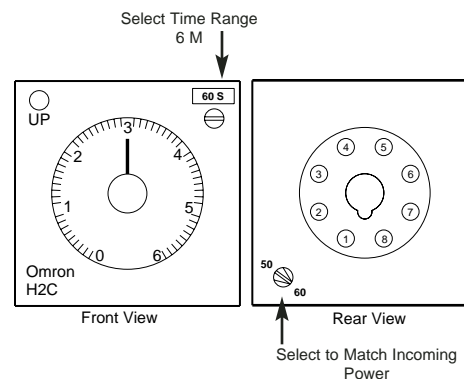

Figure 11
Timers

To Replace a Timer:

- Disconnect power to the machine at the main service switch.
- Remove the defective timer and install the replacement.
- Adjust the new timer setting to match the setting of the original timer.

To Check the Pump Timer Setting:

- Turn the power on.
- Place an object on the conveyor.
- Press the Green start button. The conveyor will start.
- When the object enters the load end tunnel the pumps will start.
- Wait for the object to exit the tunnel at the unload end.
- When the pumps stop, push the conveyor shut-off shelf to stop the conveyor.
- Measure the distance between the exit end of the tunnel and the object.
- The object should be about 1 foot past the end of the tunnel.
- If the distance is less than 1 foot, increase the pump timer setting 10 seconds. Continue to increase the timer setting in 10 second increments until the proper distance is reached.
- If the measured distance is greater than 1 foot, decrease the pump timer setting 10 seconds. Continue to decrease the timer setting in 10 second increments until the proper distance is reached.

To Check the Final Rinse Timer Setting:

- Turn the power on.
- Place on object on the conveyor.
- Press the Green start button. The conveyor will start.
- When the object enters the tunnel the pumps will start.
- Wait for the final rinse to begin.
- Press the Red stop button the instant the final rinse begins.
- Open the power rinse tank door and measure the distance between the object and the final rinse pipes.
- The object should be 2 feet from entering the final rinse area.
- If the distance is less than 2 feet between the object and the final rinse pipes then, decrease the final rinse timer setting 10 seconds. Continue this process until the proper distance is reached.
- If the measured distance is greater than 2 feet then, increase the final rinse timer setting 10 seconds. Continue this process until the proper distance is reached.
- Run a final test to check both timer settings.

ELECTRICAL SERVICE (Continued)

Electric Eye Energy Sentinel System (Idle Pump Shut-off/Rinse Saver)

Circuit Explanation—

The electric eyes are infrared sensors and are located on the load end of the machine. The sensors consist of an emitter and a receiver. These components switch the 120VAC control voltage supplied to the pump timer.

When an object moving on the conveyor breaks the infrared beam between the eyes, contacts (EER) close and complete the 120VAC circuit (Wires #7 and #27 in the control cabinet).

- The pump timer resets and the pump motors start.
- The pump timer and the final rinse timer begin to time down.
- The pump timer resets each time the beam is broken.

Component Location—

Refer to Fig.12:

The Emitter is mounted on the back of the load section.
The Receiver is mounted on the front of the load section.

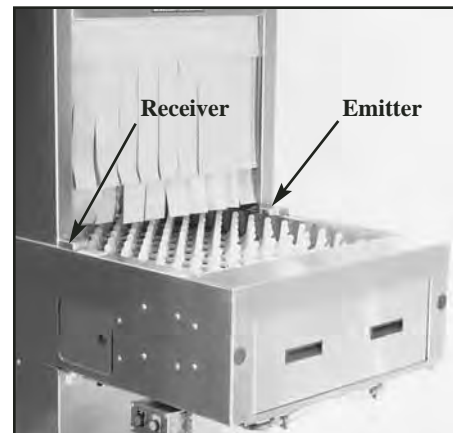

Figure 12
Electric Eye Location

Cleaning—

Be sure the emitter and receiver lenses are clean.
Wipe the lenses clean with a soft cloth and common rubbing alcohol.

Alignment—

Electric eyes do not normally require aligning except when replacing a defective unit.

The eyes are aligned visually. Make sure they oppose one another across the conveyor belt.

Replacement—

1. The Emitter is coded T183E
2. The Receiver is coded T18RW3R.
3. Remove the electric eye from the stainless steel cover. Disconnect the cable.
4. Refer to Fig.13 and mount the new eye in its cover using the nut provided. Recess the sensor 1/16" in the cover to protect the lens.

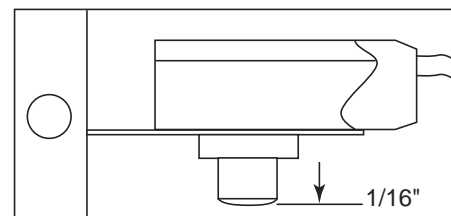

Figure 13
Electric Eye Mounting

Electric Eye Energy Sentinel System (Cont.d)

Electric Eye Bypass Switch—

NOTE:

All Upright Conveyor models have a switch located in the center of the main control cabinet for bypassing the Electric Eye Energy Sentinel System (See Fig.14).

Place the switch in the Automatic position to activate the Electric Eye system.

- Pumps run when an object enters the load end tunnel.
- Timers control the pump run time and the final rinse.



Figure 14
Bypass Switch

(Refer to the Pump Timer and Final Rinse Timer service section for instructions on timer settings)

Place the switch in the Manual position to disconnect the Electric Eye System.

- Pumps and final rinse run continuously when the Green start button is pressed.
- Pumps and final rinse shut down when the Red stop button is pressed.

Troubleshooting—

• A failure in the electric eye system most often results in the following conditions:

1. Pumps run constantly.
2. Pumps will not run at all.

• Inspect the components to isolate the defective component:

1. Make sure that the bypass switch is in the automatic position.
2. Inspect and clean the lenses of the receiver and the emitter.
3. Check that electric eyes are aligned.

• Check the indicator lights on the back of the electric eyes: (See Figure 15.)

1. Remove two screws holding electric eye covers. Rotate covers away from tunnel end so you can see indicator lights inside the covers. Do not remove eyes from covers.
2. Make sure that the electric eyes are aligned opposite of each other across the belt.
3. Make sure that both Green LED's are ON.
4. Block the beam completely. The Receiver Yellow LED should be OFF.
5. Unblock the beam completely. The Yellow LED should be ON.
6. If all LED's check OK, but the system fails to operate, try replacing the receiver first, and then the emitter.

Figure 15-
Electric Eye
Indicator Lights

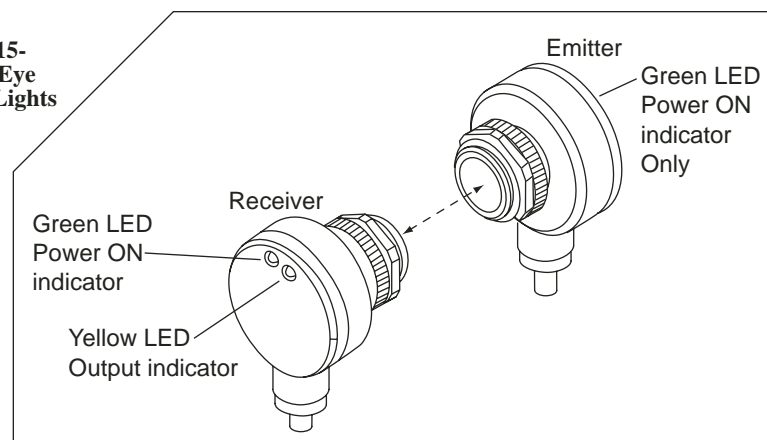

ELECTRICAL SERVICE (Continued)

Automatic Fill/Low Water Heat Protection

Dual Float Switches—

Refer to Fig. 16

Each tank contains a dual float. The device consists of an angled stem containing two reed switches. Two stainless steel ball floats slide over the stem and are free to move up and down. The floats contain magnets. When the float moves on the stem, it opens and closes its associated reed switch inside the stem. The reed switches control relays. The relays control the automatic fill and heat for different parts of the machine. Float switches and their relays operate on 24VAC.

Circuit Explanation—

The following is a general explanation of the float switch circuit. Refer to the electrical schematic on your machine for a detailed description of the individual floats, relays, and wiring.



Figure 16
Dual Float Switch Assembly

Bottom Float and Reed Switch:

- The bottom float controls the heat.
- When the bottom float is down, the bottom reed switch is Normally Open (NO).
- When the bottom float is up, the bottom reed switch is Normally Closed (NC).

Top Float and Reed Switch:

- The top float controls a fill valve.
- When the top float is down, the top reed switch is Normally Open (NO).
- When the top float is up, the top reed switch is Normally Closed (NC).

The Top and Bottom Floats work together:

Initial Fill—

- When the tank is completely empty, the top float is down and its reed switch is NO.
- The control relay for the float switch is de-energized.
- The fill valve for the tank is energized and the tank begins to fill with water.
- As the water level in the tank rises, the bottom float begins to move up.
- When the bottom float is completely up, its NO reed switch contacts close.
- This prepares the heat circuit, but the heat Does Not energize at this time.
- The tank continues to fill until the top float is completely up.
- The top float's NO reed switch contacts close. Its control relay energizes.
- The fill valve de-energizes.
- The heat circuit energizes through the NC contacts of the bottom float and the contacts of the control relay.

During Normal Operation—

- If the water level in a tank falls below the level of the top float, the top float moves down and its reed switch contacts open.
- When the water level falls below the level of the bottom float, the bottom float moves down and its reed switch opens.
- The control relay de-energizes. The fill valve energizes and refills the tank.
- The heat circuit will de-energize until the water level in the tank raises the top float again.
- The bottom float keeps the heat circuit ready as long as the water level is above the level of the bottom float.

Automatic Fill/Low Water Heat Protection (Continued)

Troubleshooting:

Each dual float controls the fill and heat circuit for a particular part of the machine.

Refer to the chart below:

DUAL FLOAT LOCATION →	POWER RINSE TANK	WASH TANK	PREWASH TANK
DUAL FLOAT CONTROLS →	<ul style="list-style-type: none"> • 2CR control relay • Water level in rinse tank • Rinse tank heat • Booster tank heat — (Champion Built-in Only) • Fill through final rinse valve final rinse piping and nozzles 	<ul style="list-style-type: none"> • 3CR control relay • Water level in wash tank • Wash tank heat • Fill through wash tank fill solenoid valve • Water enters machine at top of hood 	<ul style="list-style-type: none"> • 4CR control relay • Water level in prewash tank • NOTE: Prewash tank does not have tank heat • Fill through prewash tank fill solenoid valve • Water enters the machine at top of hood



NOTE:

The Power Rinse Tank dual float controls the heat circuit of the OPTIONAL Champion built-in booster (Steam or Electric). 120VAC Booster Control Voltage is supplied from the rinse tank heat control thermostat to the booster heat control thermostat.

Identifying a Dual Float Problem:

The most common trouble conditions associated with a dual float failure are:

Wash / Prewash Tank

1. The tank fills constantly.
2. The tank heat will not come on.

Power Rinse Tank

1. The final rinse runs constantly/No rinse tank heat.
2. The booster heat will not come on.

Inspect the Dual Float:

1. Be sure that the dual float assembly is clean and free of scale build-up.
2. Be sure that the stainless steel balls on the float assembly move up and down freely.

In addition to checking the float operation, perform the following—

System Checks:

1. All drain valves are fully closed.
2. Incoming water supply Flow Pressure is 20-22 PSI.
3. Fuses in control cabinet are good (Electric Heat Only).
4. Steam supply and steam traps operate correctly.
5. Tank Heat thermostats and/or High limit thermostats operate correctly.
6. Booster Heat thermostats and/or High limit thermostats operate correctly.
7. Electric Eye Bypass switch is in the Automatic position.

Refer to the Troubleshooting Diagrams on the next page.

DUAL FLOAT TROUBLESHOOTING DIAGRAMS

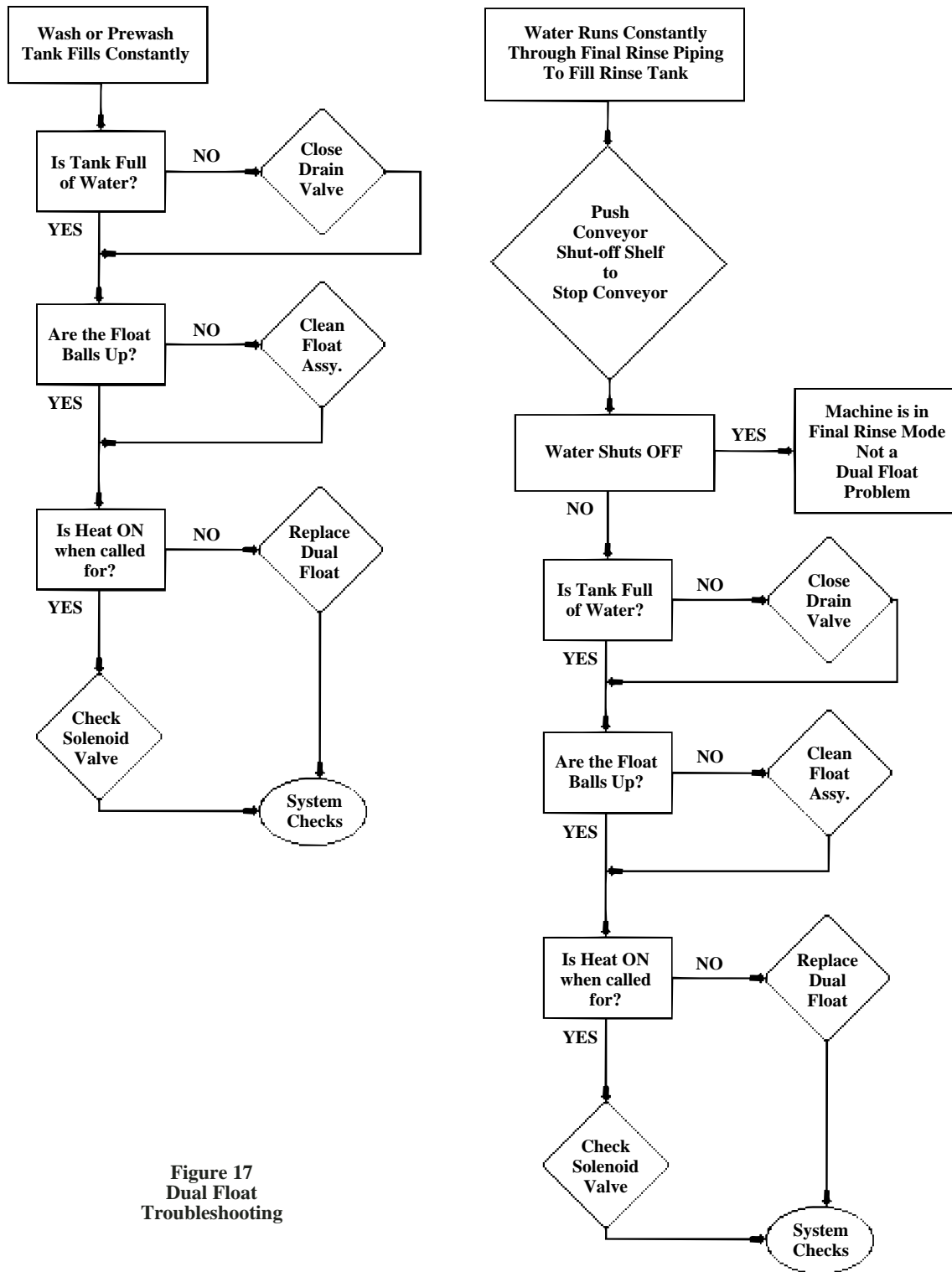

Figure 17
Dual Float
Troubleshooting

ELECTRICAL SERVICE (Continued)

Thermostat Locations and Adjustments

Refer to Fig. 18

Electric tank heat is controlled by two thermostats:

1. The Control Thermostat which regulates the temperature.
2. The High Limit Thermostat which protects from overheating.

Location:

Tank with Refuse Bucket – Both thermostats located on the side of the tank.

Tank without Refuse Bucket – Both thermostats located on the front of the tank.

Adjustment:

The Control Thermostat has an adjustment screw on one side.

- The thermostat is wired Normally Closed.
- Turn the adjustment screw clockwise to increase the temperature in the tank and counterclockwise to decrease the temperature in the tank.

The High Limit Thermostat is not adjustable. It contains a red reset button in its center.

- The red button pops out if the temperature in the tank exceeds 210°F.
 - Press the red button in to reset the high limit.
- Determine the cause of the high temperature condition.

Refer to Fig. 19 and Fig. 20.

Electric Booster Heat is controlled by two thermostats:

1. The Control Thermostat which regulates the temperature.
2. The High Limit Thermostat which protects from overheating.
3. Each tank has a control and a high limit thermostat.

Location:

The control thermostats are enclosed in black boxes mounted in front of the booster tanks on the base of the unload section of the machine. The high limit thermostats are enclosed in boxes mounted on the top of each booster tank.

Adjustment:

The control thermostat has an adjustment screw on one side.

- The thermostat is wired Normally Closed.
- Turn the adjustment screw clockwise to increase the booster tank temperature and counterclockwise to decrease the booster tank temperature.

The High Limit Thermostat is a bimetal snap design. It is not adjustable.

- A button with a red dot in the center pops out when the temperature exceeds 210°F.
- Press the red reset button in to reset the high limit. Determine the cause of the high temperature condition.

Tank Heat and Booster Heat (Steam)

Control thermostats regulate the steam supplied for tank heat and steam booster. The control thermostats are the same type as the electric heat. High limit thermostats are not required. High temperature protection is supplied by a steam pressure relief valve.

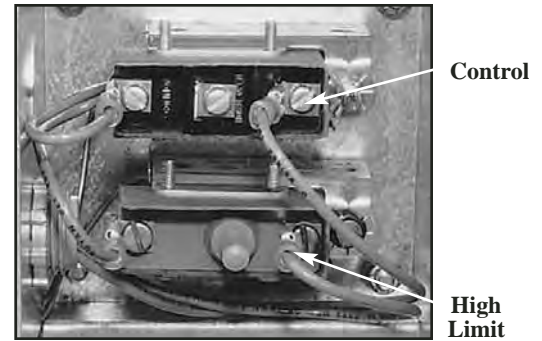

Figure 18
Electric Tank Heat Thermostats

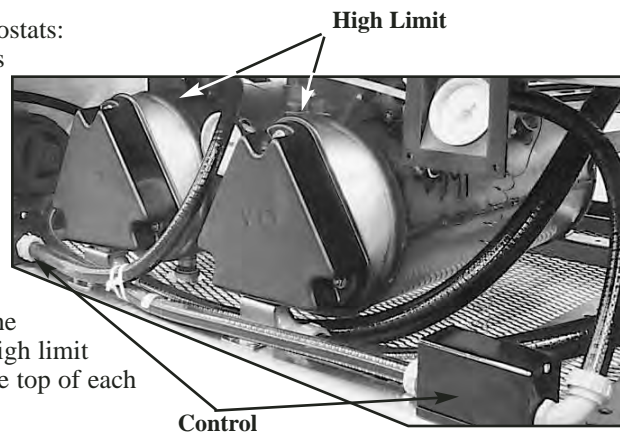

Figure 19
Electric Booster
Thermostats



Figure 20
Booster High Limit

ELECTRICAL SERVICE (Continued)

Motors

Motor Specifications:

Voltage:	Standard motors are multi-voltage	
	Low Voltage:	208-230V
	High Voltage:	460V
	Non-standard motors are single voltage	
	575V (Canada)	
Phase:	All motors are 3-phase.	
Horsepower:	Prewash Pump:	1, 2 or 3 HP
	Wash Pump:	3 HP
	Rinse Pump:	3 HP
	EconoRinse Pump:	1/4 HP
	Conveyor Drive:	1/2 HP
	Blower dryer:	2 HP

Wiring Connections

Refer to the diagrams below for

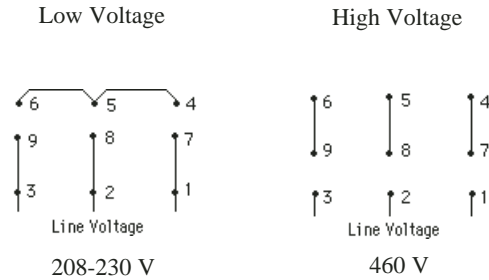

Figure 21
Motor Wiring Connections

Troubleshooting:

Motor will not run:

1. Check incoming 3-phase power to control cabinet.
2. Check for tripped motor starter overload in control cabinet.
(Refer to Motor Starter overload service section for the proper setting)
3. Check for 3-phase power at motor contactor.

Motor runs hot and trips motor starter overload:

1. Check for proper voltage between L1-L2, L2-L3, L1-L3.
2. Check FLA on motor leads L1, L2, L3 using amp tester.
(Motor full load amp (FLA) ratings are stamped on motor nameplate).

Motor Replacement:

1. Disconnect the power to the machine.
2. Disconnect the wires at the motor junction box.
3. Make note of the motor connections in order to phase the replacement correctly.
4. Install the new motor and check for proper rotation.
5. Proper shaft rotation is clockwise looking at the rear of the motor.
6. Replacement motors are available as complete assemblies.
7. Champion cannot provide replacement bearings, stators, or rotors as individual motor repair parts.
8. When requesting a replacement motor, please have available:
 - The machine model number.
 - The machine serial number.
 - The motor location, i.e. (prewash tank, conveyor drive, etc.) and the machine voltage.

MECHANICAL SERVICE

PUMP SEAL REPLACEMENT:



WARNING:

Disconnect all power to the machine at the main power source and place a tag at the disconnect switch to show that work is being done on the circuit.

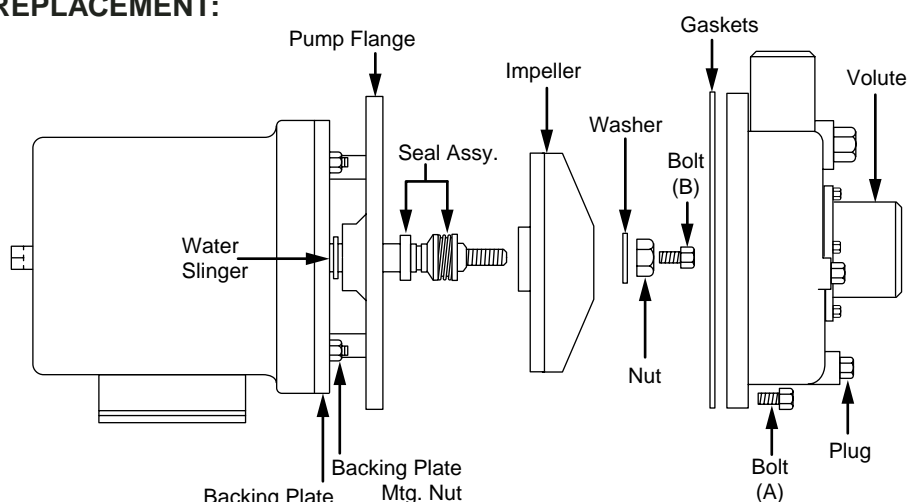

Figure 22
Pump Seal Replacement

1. Disconnect the power to the machine.
2. Drain the machine. Remove the plug from the lowest point on the pump volute and drain the pump.
3. Remove the pump hoses.
4. Disconnect the wires to the motor at the motor junction box.
5. Unbolt the motor from the base of the machine and remove the motor and pump.
6. Remove all the bolts (A) on the volute and carefully remove the volute from the pump flange.
7. Lock the motor shaft holding the square end of the rear shaft with a wrench or vise grips.
8. Remove the impeller retaining bolt (B). Remove the large retaining nut and washer.
9. Remove the impeller using a strap wrench. Turn it counterclockwise.
10. Remove the old seal and discard. Check the seal seat in the pump flange and clean thoroughly.
11. Clean the seating surface on the motor shaft with #600 emory paper or crocus cloth.
12. Check the water slinger and replace if worn or missing. Remove the (4) backing plate mtg. nuts to gain access to the slinger.
13. Press the rubber seal and ceramic into the pump flange. Use a water soluble lubricant. Keep the ceramic clean.
14. Install the rotating part of the seal on the shaft with the graphite surface toward the ceramic. Use a water soluble lubricant.
15. Reinstall the impeller, washer, lock-nut, and bolt. Install new flange gaskets. Bolt the volute to the flange.
16. Reinstall the pump and motor assembly on the base of the machine and reconnect the pump hoses.
17. Reconnect the power and fill the tank with water. Check for leaks.
18. Bump start the pump to check the motor for correct rotation.
19. Proper shaft rotation is clockwise looking at the rear of the motor.

MECHANICAL SERVICE (Continued)

Cross Flow Elbows

Proper water levels are maintained in the tanks through a system of pipes and elbow fittings. This system is called a water cross flow system. Water flows by gravity from the final rinse end of the machine back towards the prewash tank.

Cross flow elbows are placed in the tanks as required to adjust the flow of water from one tank into the other. The proper adjustment of the elbows is important for the correct operation of the machine.

— **IMPORTANT NOTE** —

Cross flow elbow adjustment procedures can be found in Appendix C at the end of this manual. Refer to those instructions before changing the position of any cross flow elbow.

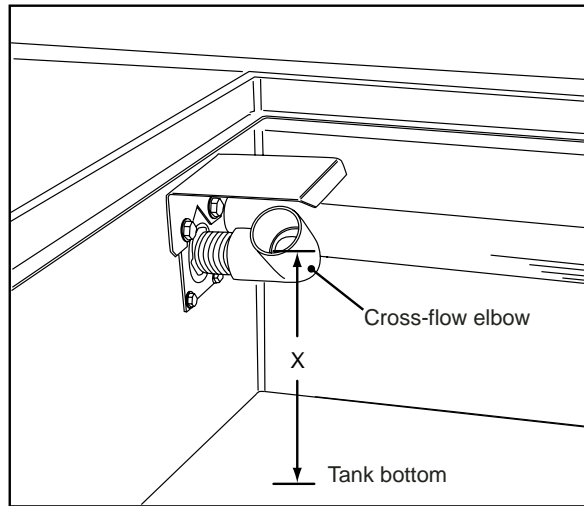

Figure 23
Cross Flow Elbow

Solenoid Valve Repair:

Champion uses Asco and Parker solenoid valves. Repair kits and replacement coils are available from Champion Industries and Champion Parts Distributors.

Refer to Fig. 24 and Fig. 25

To Repair a solenoid Valve:

1. Turn off the water or steam supply.
2. Disconnect the power to the machine.
3. If repairing a Parker valve:
 - a. Remove the screw holding the coil.
 - b. Lift the coil off the bonnet.
 - c. Unscrew the top of the valve.
 - d. Inspect the valve body. If pitted or scored, replace the entire valve.
 - e. Replace the parts contained in the repair kit. Reassemble the valve.
4. If repairing an Asco valve:
 - a. Remove the cap holding the coil.
 - b. Remove the (4) bonnet bolts.
 - c. Inspect the valve body and replace if pitted.
 - d. Replace the parts in the kit. Reassemble the valve.



Figure 24 - Parker Valve



Figure 25
Asco Valve

REPLACEMENT PARTS



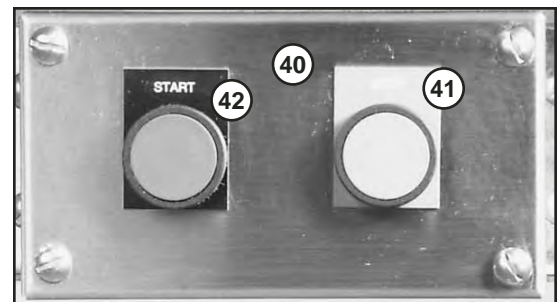
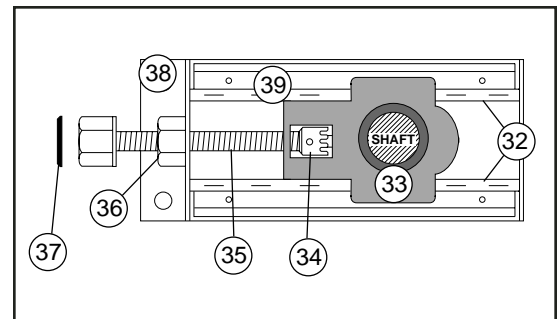
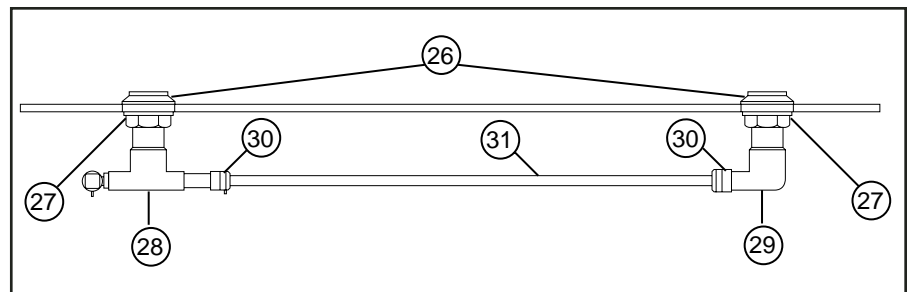
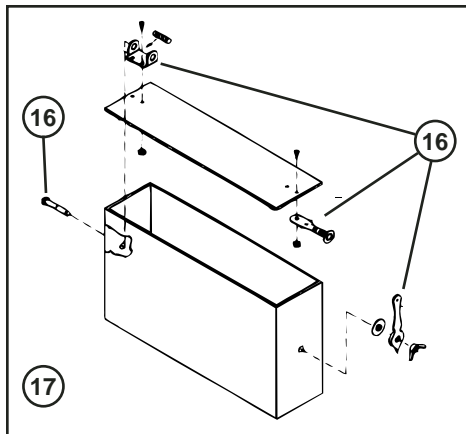
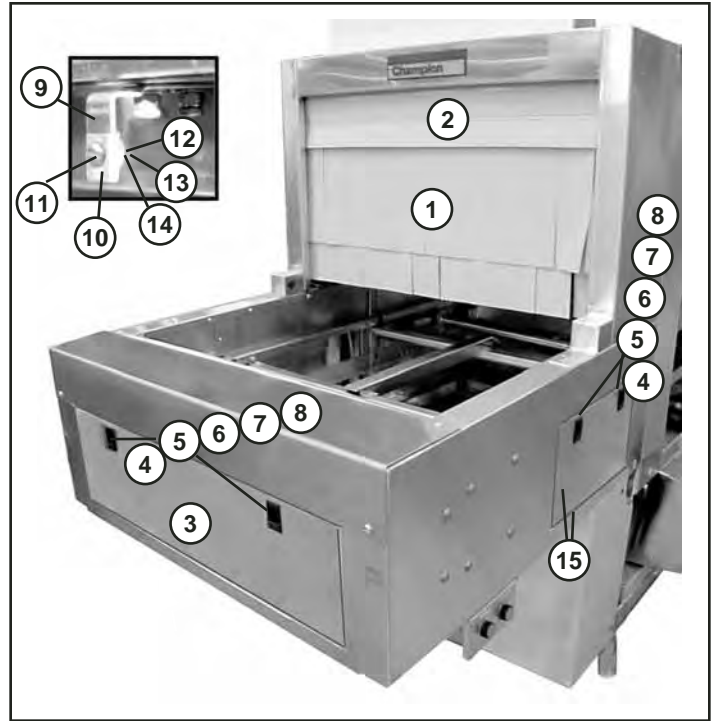
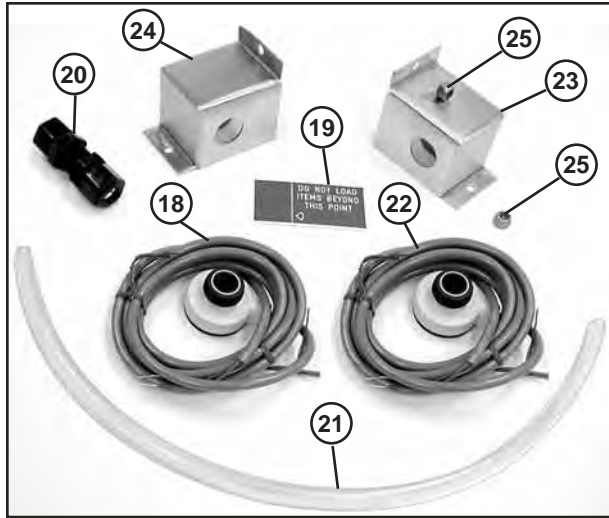

Figure 26 - Load Section

LOAD SECTION

Fig. 26 Item No.	Part No.	Part Description	Qty
1	112446	Curtain (32 x 19) Entrance.....	1
2	108642	Rod, Curtain (5/16 x 33-5/8).....	1
3	320895	Door, Access (8 x 27-5/8).....	1
4	112057	Latch, Access Door (per Door).....	2
5	320578	Hinge, Access Door (per Door).....	4
6	320579	Plate, Access Door Hinge.....	2
7	100750	Screw (6-32 x 3/8) Flat Head.....	4
8	104971	Nut, Grip 6-32.....	4
9	320901	Bracket, Perimeter Panel.....	4
10	112267	Fastener, J-Clip.....	4
11	100073	Screw (1/4-20 x 1/2) Truss Head.....	4
12	107967	Nut, Grip (1/4-20 w/Nylon Insert).....	4
13	106482	Washer, Lock (1/4 Split).....	4
14	106026	Washer, Flat (1/4 x 5/8 x 1/16 SST).....	4
15	320893	Door, Access (8 x 14).....	1
15	322008	Door, Access (8 x 16).....	1
16	201589	Damper, Regulator Assembly.....	1
17	401486	Stack, Vent (4 x 24).....	1
18	112242	Receiver, Electric Eye.....	1
19	107003	Load, Placard.....	2
20	112245	Union, Bulkhead 3/8 Plastic.....	2
21	205907	Tubing.....	2
22	112241	Emitter, Electric Eye.....	1
23	323229	Electric Eye Weldment RH.....	1
24	323230	Electric Eye Weldment LH.....	1
25	108954	Nut Grip 6-32 w/nylon insert.....	4
26	106153	Flushing Nozzle.....	2
NS	106382	Screw 6-32 x 3/8 Truss Head.....	2
NS	107033	Washer .208 x .437 x .047.....	2
27	108417	Nut, Retaining.....	2
28	309711	Tee & Elbow Weldment L-R.....	1
28	323595	Tee & Elbow Weldment R-L.....	1
29	309709	Elbow Weld, Flushing.....	1
30	105994	Clamp, Hose.....	2
31	107935	Tube (5/8 ID x 5/16 OD).....	A/R
32	309386	Track, Take-up Bearing Assembly.....	4
33	109959	Bearing, Idler Shaft.....	2
34	111082	Roll Pin.....	2
35	309397	Screw, Adjusting.....	2
36	107691	Nut, Jam.....	2
37	109029	Plug, Plastic.....	2
38	309385	Bracket, Take-up.....	2
39	110085	Nut, Castle.....	2
40	406225	Station, Start/Stop (Includes Items 40-47).....	1
41	107617	Nameplate, Stop.....	1
42	107614	Nameplate, Start.....	1
43	111616	Contact Block, NC.....	1
44	111617	Contact Block, NO.....	1
45	111615	Pushbutton, RED (Stop).....	1
46	111614	Pushbutton, GREEN (Start).....	1
47	113140	Boot, Silicone, Pushbutton.....	1

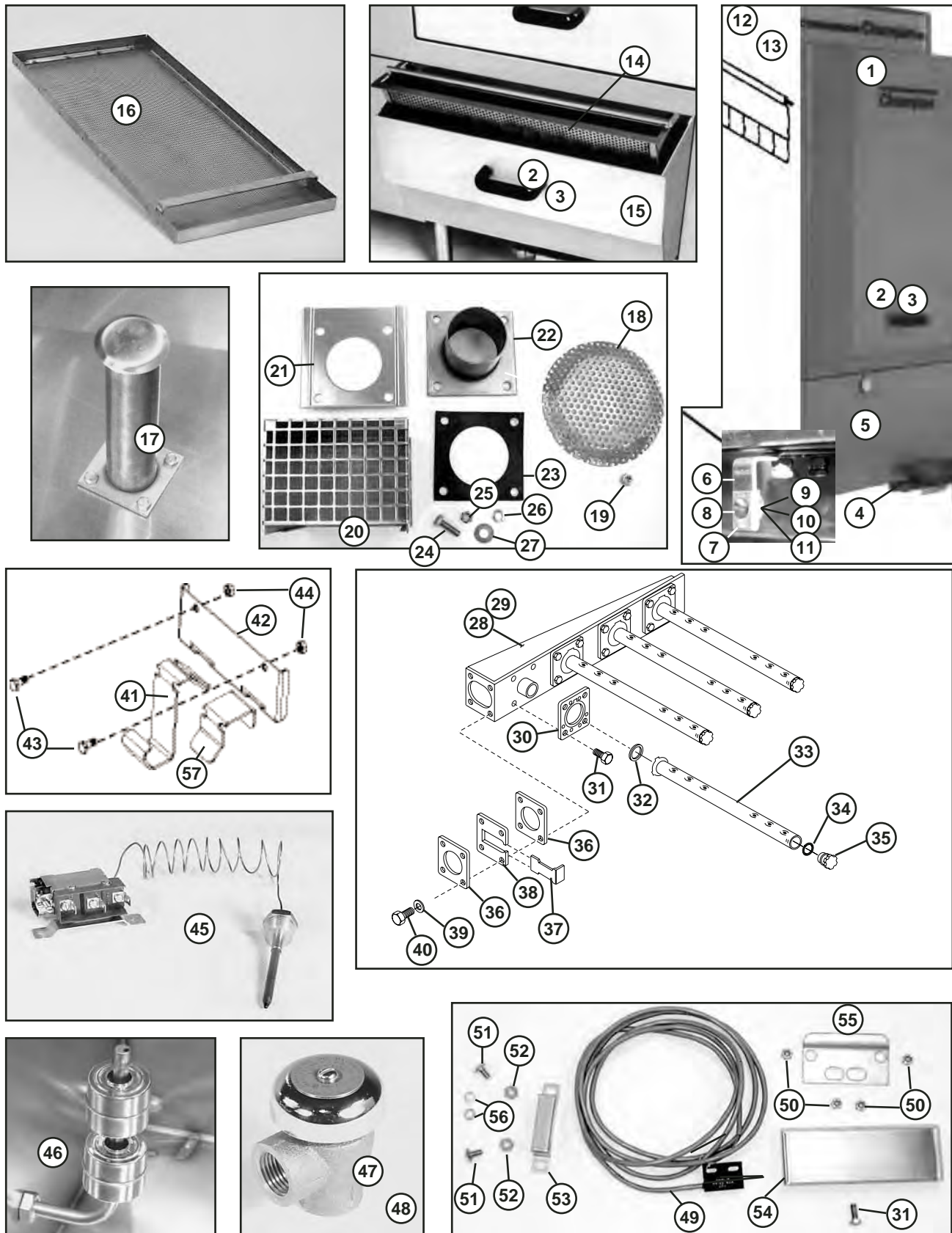

Figure 27 - Prewash Section

PREWASH SECTION

Fig. 27 Item No.	Part No.	Part Description	Qty
1	308900	Door, (12" B2 Section Standard)	1
1	307882	Door, (24" B4 Section Standard)	1
1	308887	Door, (12" B2 Section Lift-Out)	1
1	306953	Door, (24" B4 Section Lift-Out)	1
2	108966	Handle, Door (per Door).....	1
3	100073	Screw (1/4-20 x 1/2) Truss Head	2
4	109072	Drain Valve.....	1
5	113622	Thermometer (4 ft.) Gas Filled (Replaces 108391).....	1
6	320901	Bracket, Perimeter Panel	4
7	112267	Fastener, J-Clip.....	4
8	100073	Screw (1/4-20 x 1/2) Truss Head	4
9	107967	Nut Grip (1/4-20 w/Nylon Insert).....	4
10	106482	Washer, Lock (1/4 Split)	4
11	106026	Washer, Flat (1/5 x 5/8 x 1/16 SST)	4
12	112445	Curtain, Short (32 x 14)	1
13	108642	Rod, Curtain (5/16 x 33-5/8).....	1
14	320922	Basket, Refuse (B2 Section)	1
14	321969	Basket, Refuse (B4 Section)	1
15	305706	Cover, Refuse (B2 Section).....	1
15	305720	Cover, Refuse (B4 Section).....	1
16	305705	Screen, Scrap (B2 Section)	1
16	320921	Screen, Scrap (B3 w/o Optional Refuse Bucket).....	1
16	321972	Screen, Scrap (B4 w/ Optional Refuse Bucket).....	1
16	321990	Screen, Scrap (B4 w/o Optional Refuse Bucket).....	1
17	308322	Overflow (7-3/4") Before S/N J1436.....	1
17	325838	Overflow (8-1/2") After S/N J1436	1
18	304816	Strainer (6" Diameter).....	1
19	100141	Nut Grip 1/4-20 SST	1
20	319742	Hood, Pump Suction	1
21	319743	Plate, Pump Suction	1
22	313300	Flange Weld Suction	1
23	104640	Gasket 4Sq x 1/8TK.....	1
24	100740	Bolt 5/16-18 x 1 Hx head.....	4
25	100154	Nut Plain 5/16-18	4
26	106013	Washer, Lock 5/16 Split.....	4
27	102376	Washer, 5/16 x 3/4 x 1/16	4
28	320779	Upper, Manifold B2	1
28	317240	Upper, Manifold B3	1
28	317237	Upper, Manifold B4	1
29	320780	Lower, Manifold B2.....	1
29	320283	Lower, Manifold B3.....	1
29	317240	Lower, Manifold B4.....	1
30	111456	Locking Plate (per Spraypipe)	1
31	111478	Bolt 10-32 x 1/2 Hex Hd SST (per Locking Plate)	1
32	111505	O-Ring, Spraypipe (per Spraypipe)	1
33	321472	Spraypipe B2.....	2

PREWASH SECTION (CONT.)

Fig. 27 Item No.	Part No.	Part Description	Qty
33	321472	Spraypipe B3	7
33	321472	Spraypipe B4	9
34	104414	O-Ring, Spraypipe End Plug (per Spraypipe)	1
35	112240	Plug, Spraypipe End (per Spraypipe)	1
**	900777	Spraypipe Assembly (includes 33, 34, 35)	A/R
36	111456	Manifold Gasket (per Manifold)	1
37	321307	Slide, Adjustable Restrictor, Lower Manifold	1
38	319195	Plate, Adjustable Restrictor, Lower Manifold	1
39	104682	Washer, 1/4 Split Lock (per Manifold)	4
40	100736	Bolt, 1/4-20 x 3/4 Hex Head (per Manifold)	4
41	327102	Hook, Door Stop/Catch Combo	1
42	325920	Bracket & Door Stop/Catch Combo	1
43	100734	Screw (1/4-20 x 5/8 Hex Head)	2
44	100141	Nut, Grip (1/4-20)	2
45	109069	Thermostat (Optional) Cold Water	1
46	111019	Dual Float Switch.....	1
47	100500	Breaker, Vacuum 1/2 (bronze)	1
*48	108349	Repair Kit, 1/2" Vacuum Breaker (not shown) (Prior to S/N J1533) (bronze)	1
*48	113221	Repair Kit, 1/2" Vacuum Breaker (not shown) (After S/N J1534) (plastic).....	1
49	111090	Hamlin Reed Switch	1
50	108954	Nut, Grip (6-32 w/Nylon Insert)	2
51	100007	Screw (10-32 x 3/8) Truss Head	2
52	100194	Nut, Grip (10-32)	2
53	111026	Magnet, Large SST	1
54	319991-1	Cover, Door Switch/Bracket	1
55	319993	Back Plate, Door Switch Cover	1
56	106486	Washer Lock #10 Split	2
57	325922	Stop, Door Catch/Stop Combo	1
*—	900836	Kit*Repair, 1/4" & 1/2" Vacuum Breaker (Includes one each of 108349, 113219 and 113221)	

* Kit was created to repair either style (plastic or bronze) vacuum breaker. Plastic style is no longer available.

WASH/RINSE SECTION

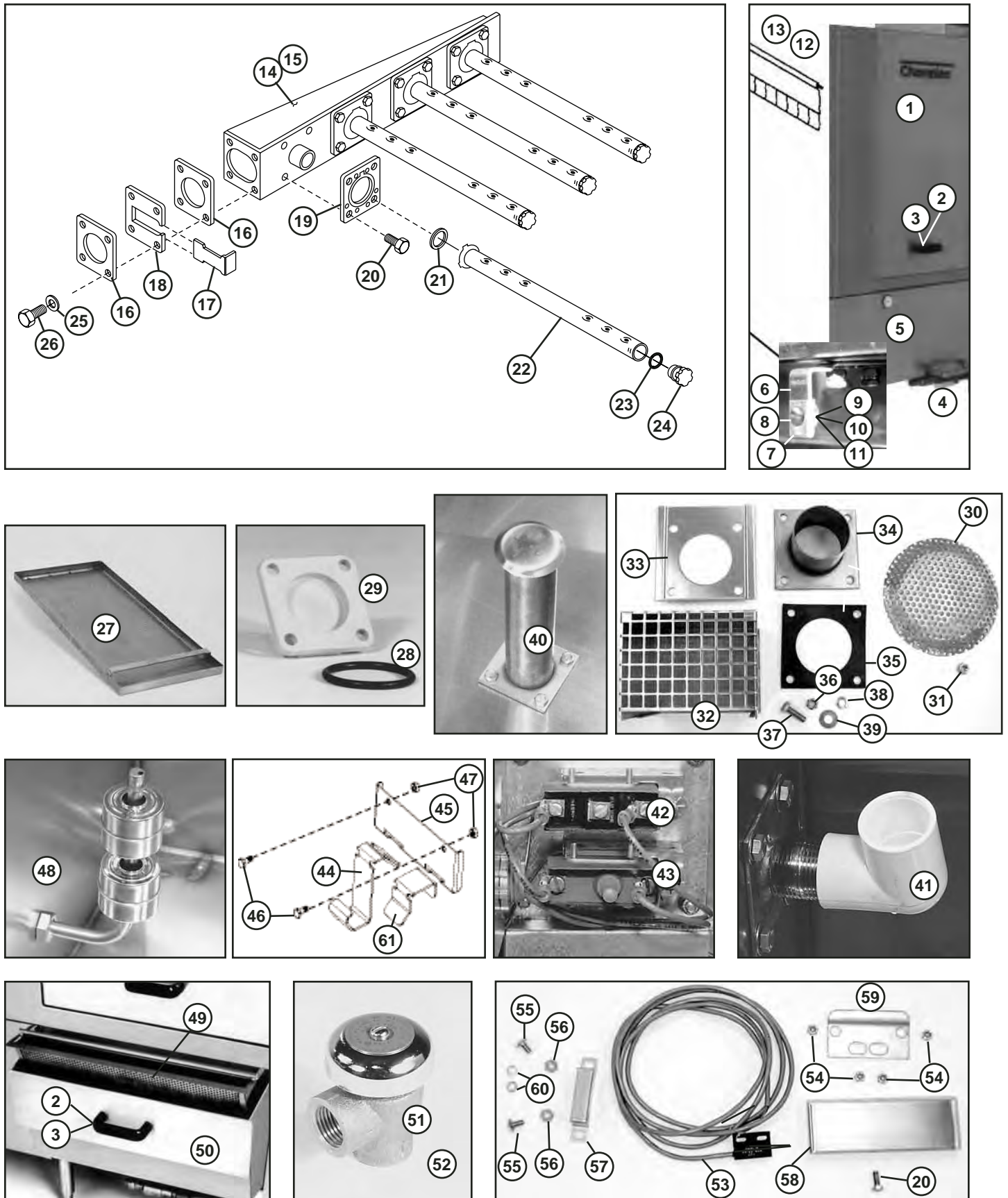

Figure 28 - Wash/Rinse Section

WASH / RINSE SECTION

Fig. 28 Item No.	Part No.	Part Description	Qty
1	307882	Door, (24"-C3/C4 Section Standard)	1
1	306953	Door, (24"-C3/C4 Section Lift-out)	1
2	108966	Handle, Door (per Door).....	1
3	100073	Screw (1/4-20 x 1/2) Truss Head	2
4	109072	Drain Valve.....	1
5	113622	Thermometer (4 ft.) Gas Filled (Replaces 108391).....	1
6	320901	Bracket, Perimeter Panel	2
7	112267	Fastener, J-Clip.....	2
8	100073	Screw (1/4-20 x 1/2) Truss Head	2
9	107967	Nut, Grip (1/4-20 w/Nylon Insert)	2
10	106482	Washer, Lock (1/4 Split)	2
11	106026	Washer, Flat (1/4 x 5/8 x 1/16 SST)	2
12	112445	Curtain, Short (32 x 14)	1
13	108642	Rod, Curtain (5/16 x 33 5/8).....	1
14	317240	Upper Manifold (C3/C4 Section).....	1
15	320283	Lower Manifold (C3 Section)	1
15	317237	Lower Manifold (C4 Section)	1
16	111456	Manifold Gasket (per Manifold)	1
16	111456	Manifold Gasket (per Manifold)	1
17	321307	Slide, Adjustable Restrictor, Lower Manifold	1
18	319195	Plate, Adjustable Restrictor, Lower Manifold	1
19	111454	Locking Plate, Manifold (per Spraypipe)	1
20	111478	Bolt 10-32 x 1/2 Hex Hd SST (per Locking Plate)	4
21	111505	O-Ring, Wash Arm (per Spraypipe)	1
22	321472	Spraypipe, C3.....	7
22	321472	Spraypipe, C4.....	9
23	104414	O-Ring, Sprayarm End Plug (per Spraypipe)	1
24	112240	Plug, Spraypipe End (per Spraypipe)	1
**	900777	Spraypipe Assembly (Includes Items 22, 23, 24).....	
25	104682	Washer, 1/4 Split Lock (per Manifold)	4
26	100736	Bolt, 1/4-20 x 3/4 Hex Head (per Manifold)	4
27	320921	Screen, Scrap (C3 Section w/o Optional Refuse Bucket)	2
27	322098	Screen, Scrap (C3 Section w/ Optional Refuse Bucket)	2
27	321990	Screen, Scrap (C4 Section w/o Optional Refuse Bucket)	2
27	321969	Screen, Scrap (C4 Section w/ Optional Refuse Bucket)	2
29	109683	Flange	1
28	112257	O-Ring	1
30	304816	Strainer (6" Diameter).....	1
31	107967	Nut, Strainer Retaining	1
32	319742	Hood, Pump Suction	1
33	319743	Plate, Pump Suction	1
34	313300	Flange Weld Suction	1
35	104640	Gasket 4Sq x 1/8TK.....	1
36	100154	Nut Plain 5/16-18.....	4
37	100740	Bolt 5/16-18 x 1 Hex Head.....	4
38	106013	Washer Lock 5/16 Split.....	4
39	102376	Washer 5/16 x 3/4 X 1/16	4
40	308321	Overflow 9" (C3/C4 Wash Tank w/ Refuse Bucket)	1

WASH / RINSE SECTION (CONT.)

Fig. 28 Item No.	Part No.	Part Description	Qty
40	305840	Overflow 9-1/2" (C3/C4 Wash Tank w/o Refuse Bucket).....	1
40	305839	Overflow 10" (C3/C4 Rinse Tank w/o Refuse Bucket).....	1
40	305840	Overflow 9-1/2" (C3/C4 Rinse Tank w/Refuse Bucket).....	1
41	110852	Elbow, Cross-flow 1 x 90° (Wash Tank only)	1
42	109069	Thermostat, Control (Steam or Electric).....	1
43	110561	Thermostat, High Limit (Electric Only)	1
44	327102	Hook, Door Stop/Catch Combo	1
45	325920	Bracket, Door Stop.Catch Combo.....	1
46	100734	Screw, Door Handle (1/4-20 x 5/8 Hex Head).....	2
47	100141	Nut, Grip (1/4-20 SST)	1
48	110854	Float Switch, Dual (C3 Wash Tank) (Before S/N J1436).....	1
48	111019	Float Switch, Dual (C3 Rinse Tank) (Before S/N J1436)	1
48	110854	Float Switch, Dual (C4 Wash/Rinse/WS Tank) (Before S/N J1436)	1
48	113291	Float Switch, Dual (Wash/Rinse Tank) (After S/N J1436).....	1
49	321595	Basket, Refuse (Optional on C3 Section)	1
49	321969	Basket, Refuse (Optional on C4 Section)	1
50	308237	Cover, Refuse Basket (Optional on C3 Section)	1
50	305720	Cover, Refuse Basket (Optional on C4 Section)	1
51	100500	Vacuum Breaker 1/2" (bronze).....	1
*52	108349	Repair Kit, Vacuum Breaker 1/2" (Not Shown) (Prior to S/N J1533) (bronze)	1
*52	113221	Repair Kit, Vacuum Breaker 1/2" (Not Shown) (After S/N J1534) (plastic).....	1
53	111090	Hamlin Reed Switch	1
54	108954	Nut, Grip (6/32 w/Nylon Insert)	2
55	100007	Screw (10-32 x 3/8) Truss Head	2
56	100194	Nut, Grip (10-32)	2
57	111026	Magnet, Large SST	1
58	319991-1	Cover, Door Switch/Bracket	1
59	319993	Back Plate, Door Switch Cover	1
60	106486	Washer Lock #10 Split.....	2
61	325922	Stop, Door Catch/Stop Combo.....	1
—	900836	Kit*Repair, 1/4" & 1/2" Vacuum Breaker (Includes one each of 108349, 113219 and 113221)	

* Kit was created to repair either style (plastic or bronze) vacuum breaker. Plastic style is no longer available.

ECONORINSE SECTION
(Optional)

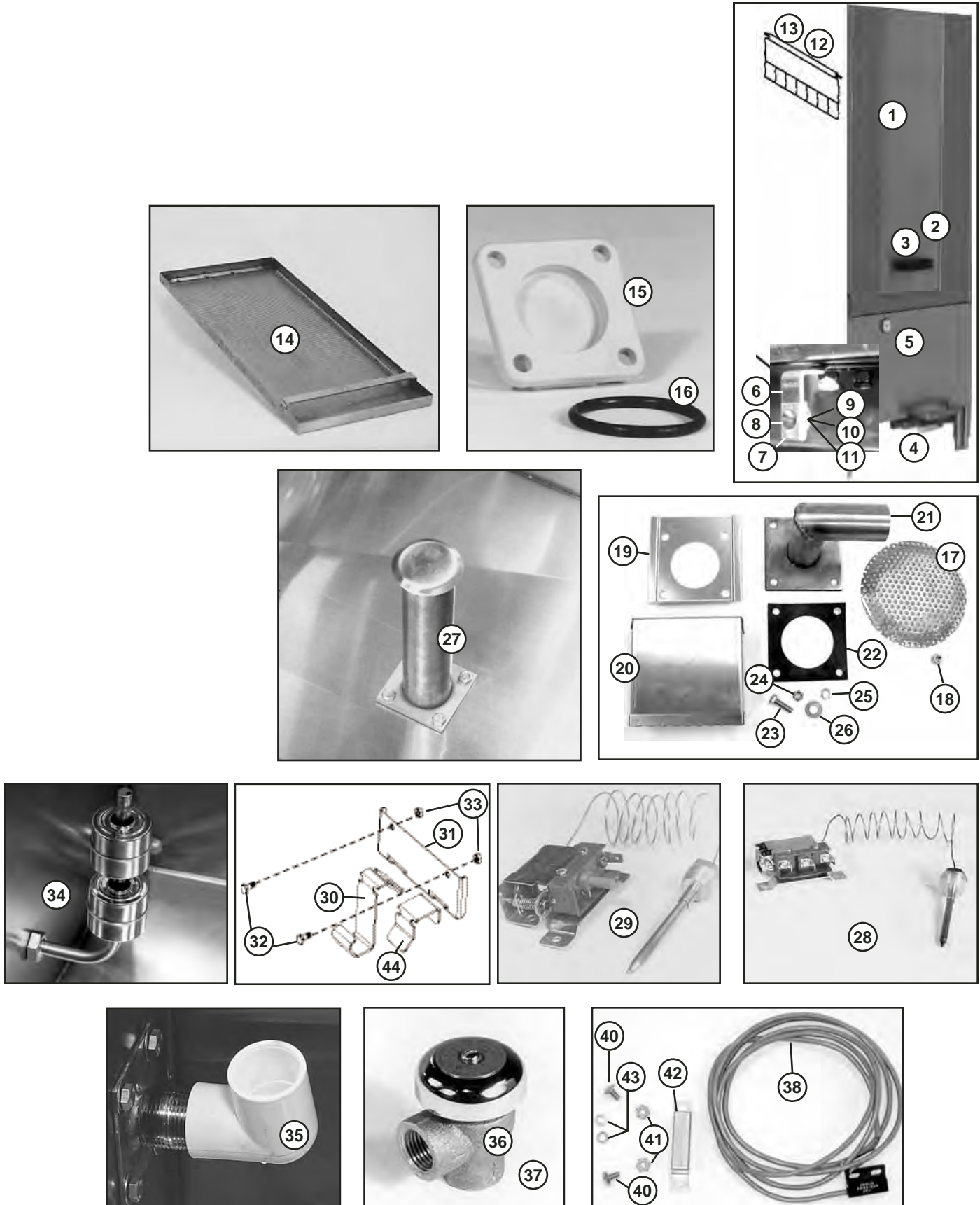

Figure 29 - EconoRinse Section

ECONORINSE SECTION OPTION

Fig. 29 Item No.	Part No.	Part Description	Qty
1	308900	Door, (12" Standard).....	1
1	308887	Door, (12" Lift-out).....	1
2	108966	Handle, Door (per Door).....	1
3	100073	Screw (1/4-20 x 1/2) Truss Head.....	2
4	109072	Drain Valve	1
5	113622	Thermometer (4 Ft.) Gas Filled (Replaces 108391).....	1
—	112089	Overlay, Gauge (Econorinse).....	1
6	320901	Bracket, Perimeter Panel.....	4
7	112267	Fastener, J-Clip	4
8	100073	Screw (1/4-20 x 1/2) Truss Head.....	4
9	107967	Nut, Grip (1/4-20 w/ Nylon Insert).....	4
10	106482	Washer, Lock (1/4 Split).....	4
11	106026	Washer, Flat (1/4 x 5/8 X 1/16 SST).....	4
12	204949	Curtain, Short (32 x 10).....	1
13	111695	Rod, Curtain (5/16 x 32-3/4).....	1
14	323441	Scrap, Screen (w/o Optional Refuse Bucket/Standard).....	1
14	323547	Scrap, Screen (w/ Lift-out Doors).....	1
14	324522	Scrap, Screen Reinforced.....	1
15	109683	Flange	1
16	112257	O-Ring	1
17	304816	Strainer (6" Diameter).....	1
18	107967	Nut, Strainer Retaining	1
	106026	Washer (1/4 x 5/8 x 1/16 SST) (Not shown).....	1
19	319743	Plate, Pump Suction	1
20	322832	Hood, Pump Suction	1
21	322818	Suction Weld Elbow E2.....	1
22	104640	Gasket, 4SQ x 1/8TK.....	1
23	100740	Bolt, 5/16-18 x 1 Hex Head.....	4
24	100154	Nut, Plain 5/16-18.....	4
25	106013	Washer, Lock 5/16 Split	4
26	102376	Washer, 5/16 x 3/4 x 1/16.....	4
27	322838	Overflow 11".....	1
28	109069	Thermostat, Control (Steam or Electric).....	1
29	110561	Thermostat, High Limit (Electric Only)	1
30	327102	Hook, Door Stop/Catch Combo.....	1
31	325920	Bracket, Door Stop/Catch Combo	1
32	100734	Screw (1/4-20 x 5/8 Hex Head).....	2
33	100141	Nut, Grip (1/4-20)	1
34	111019	Float Switch, Dual.....	1
35	110852	Elbow, Cross-Flow (1 x 90').....	1
36	100500	Breaker, Vacuum 1/2" (bronze).....	1
*37	108349	Repair Kit, 1/2" Vacuum Breaker (Not Shown) (Prior to S/N J1534) (bronze)	1
*37	113221	Repair Kit, 1/2" Vacuum Breaker (Not Shown) (After S/N J1534) (bronze)	1
38	111090	Switch, Reed	1
39	108954	Nut, Grip (6/32 w/ Nylon Insert) (Not Shown).....	2
40	100007	Screw (10-32 x 3/8 Truss Head).....	2
41	100194	Nut, Grip (10-32)	2
42	111026	Magnet, Large	1
43	106486	Washer, Lock #10 Split.....	2
44	325922	Stop, Door Catch/Stop Combo	1
*	900836	Kit*Repair, 1/4" & 1/2" Vacuum Breaker (Includes one each of 108349, 113219 and 113221) Kit was created to repair either style (plastic or bronze) vacuum breakers. Plastic style is no longer available.	

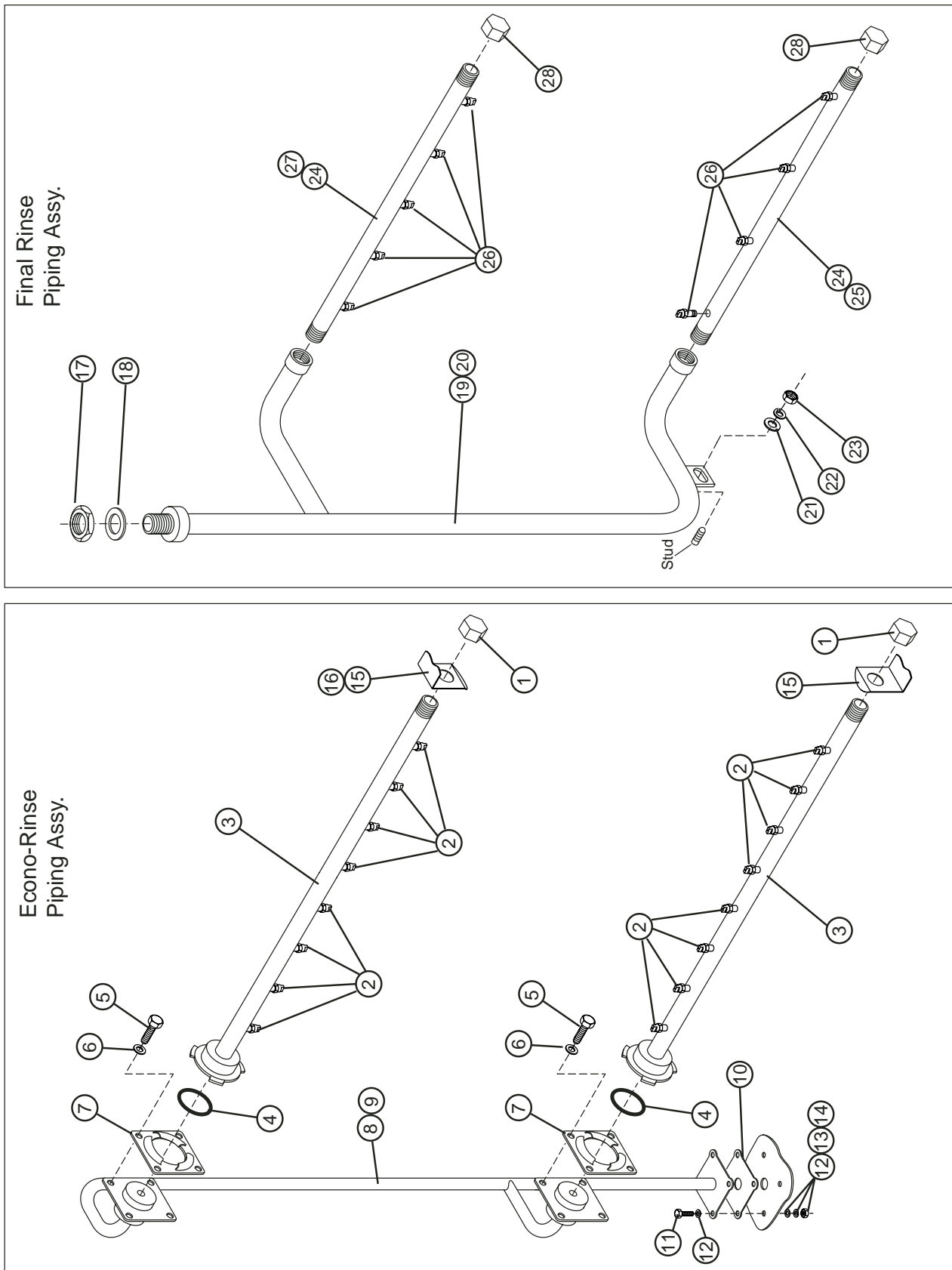

Figure 30 - EconoRinse Piping/Final Rinse Piping

ECONORINSE PIPING ASSEMBLY

Fig. 30 Item No.	Part No.	Part Description	Qty
1	106734	Cap 1/2" Plastic	2
2	180281	Nozzle, Pumped	16
3	319583	Pipe, Spray E2 Pumped Rinse	2
4	111505	O-Ring	2
5	111478	Bolt 10-32 x 1/2" Hex Head	8
6	107033	Washer, Flat 10-32	8
7	111454	Plate, Locking	2
8	320068	Manifold, E2 Rear.....	1
9	322399	Manifold, E2 Front.....	1
10	108345	Gasket, Manifold.....	1
11	100740	Bolt 5/16 x 1 Hex Head	4
12	102376	Washer, Flat 5/16.....	8
13	106013	Washer Lock 5/16	4
14	100154	Nut, Plain 5/16	4
15	319231	Bracket (1 Top) (1 Bottom).....	2
16	319271	Bracket (Top).....	1

FINAL RINSE PIPING ASSEMBLY

Fig. 30 Item No.	Part No.	Part Description	Qty
17	201236	Locknut 3/4 NP	1
18	108620	Gasket Rinse Pipe	1
19	322921	Manifold, Weldment (L-R)	1
20	322833	Manifold, Weldment (R-L)	1
21	107033	Washer, Flat 10-32	1
22	106486	Washer, Lock #10.....	1
23	104985	Nut, Plain 10-32	1
24	313285	Spraypipe Final Rinse (C8).....	2
25	205128	Spraypipe Final Rinse Lower (C6)	1
26	180282	Nozzle 1/8 Fresh Water Rinse (C8)	12
—	180282	Nozzle 1/8 Fresh Water Rinse (C6)	9
27	205127	Spraypipe Final Rinse Upper (C6).....	1
28	106734	Cap 1/2 Plastic	2

**THIS PAGE
INTENTIONALLY
LEFT BLANK**

UNLOAD SECTION

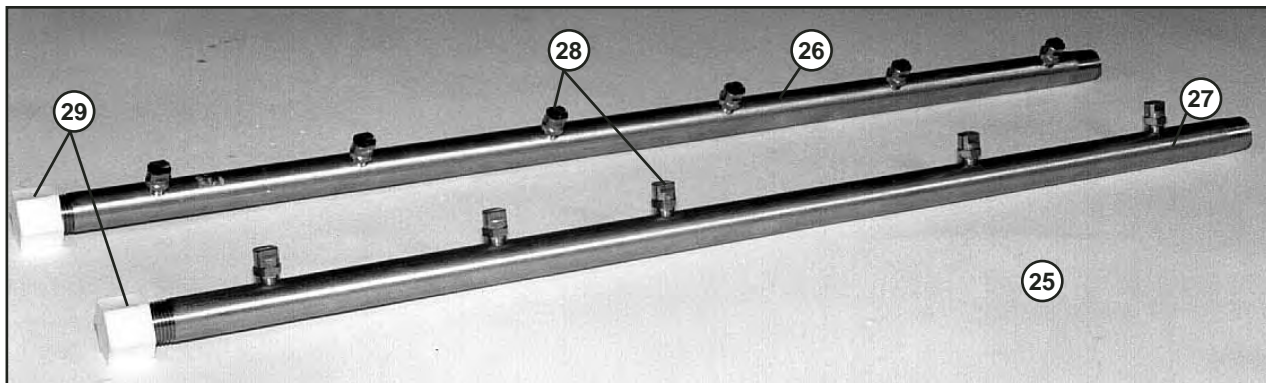
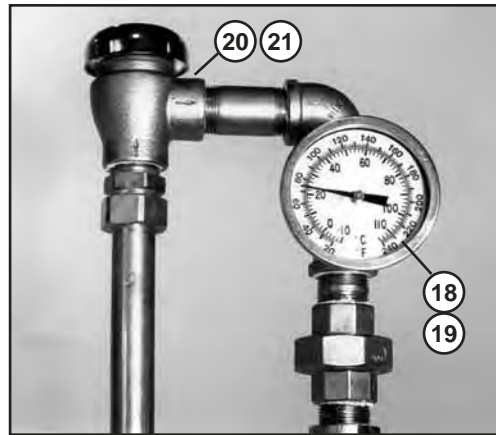
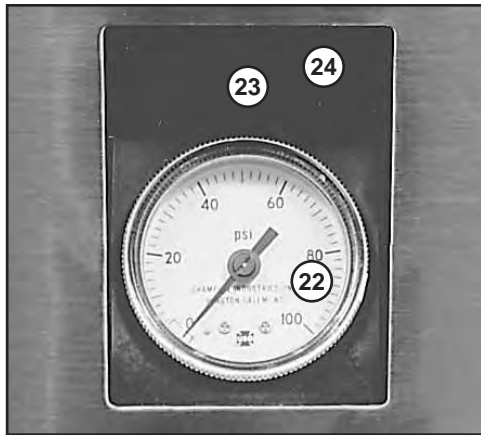
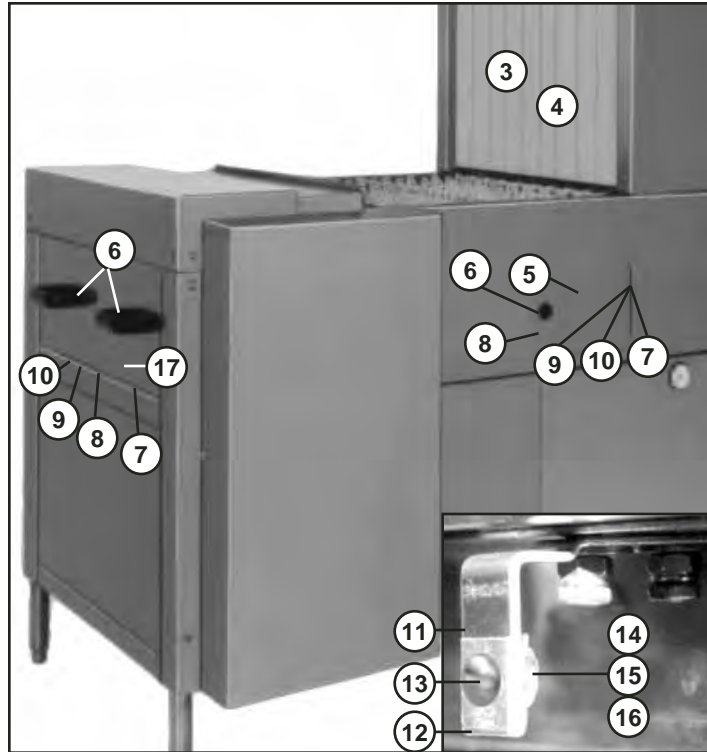
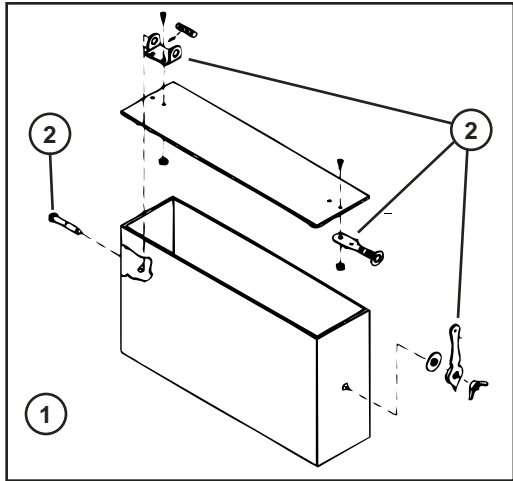

Figure 31 - Unload Section

UNLOAD SECTION

Fig. 31 Item No.	Part No.	Part Description	Qty
1	401486	Stack, Vent (4 x 24).....	1
2	201589	Damper, Regulator Assembly	1
3	112446	Curtain, Long (32 x 19)	1
4	108642	Rod, Curtain (5/16 x 33-5/8).....	1
5	320894	Door, Access Side (7 x 7-1/2)	A/R
5	322008	Door, Access Side (8 x 16)	A/R
6	112057	Latch, Access Door (per Door).....	2
7	320578	Hinge, Access Door (per Door)	4
8	320579	Plate, Access Door Hinge (per Door)	2
9	100750	Screw (6-32 x 3/8 Flat Head) (per Door).....	4
10	104971	Nut, Grip 6-32 (per Door).....	4
11	320901	Bracket, Perimeter Panel.....	4
12	112267	Fastener, J-Clip.....	4
13	100073	Screw (1/4-20 x 1/2) Truss Head	4
14	107967	Nut, Grip (1/4-20 w/ Nylon Insert).....	4
15	106482	Washer, Lock (1/4 Split)	4
16	106026	Washer, Flat (1/4 x 5/8 x 1/16 SST)	4
17	320895	Door, Access (8 x 27)	1
18	104682	Thermometer, Final Rinse.....	1
19	112090	Overlay, Final Rinse 180° - 195°	1
20	104429	Breaker, Vacuum (3/4") (bronze)	1
21	108351	Repair Kit, Vacuum Breaker (3/4") (Not Shown) (Prior to S/N J1533) (bronze)	1
21	113223	Repair Kit, Vacuum Breaker (3/4") (Not Shown) (After S/N J1534) (plastic).....	1
22	109812	Gauge, Pressure	2
23	110244	Support, Pressure Gauge	1
24	107414	Tubing, Pressure Gauge (Not Shown)	4
25	311403	Manifold, Final Rinse (Not Shown).....	1
26	313825	Upper Pipe, Final Rinse	1
27	317343	Lower Pipe, Final Rinse	1
28	104005	Nozzle, Upper Final Rinse Pipe (1/8" NPT-#8010).....	6
28	104005	Nozzle, Lower Final Rinse Pipe (1/8" NPT-#8010)	5
29	106734	Cap (1/2").....	2
*	900836	Kit*Repair, 3/4" Vacuum Breaker (Includes one each of item 21) Kit was created to repair either style (plastic or bronze) vacuum breaker. Plastic style no longer available.	

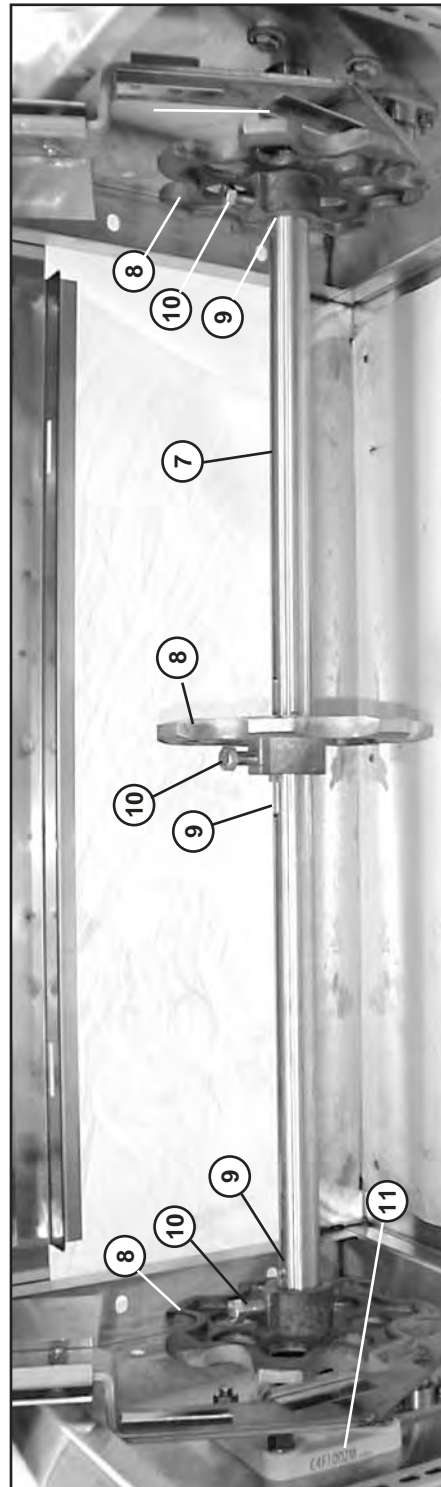
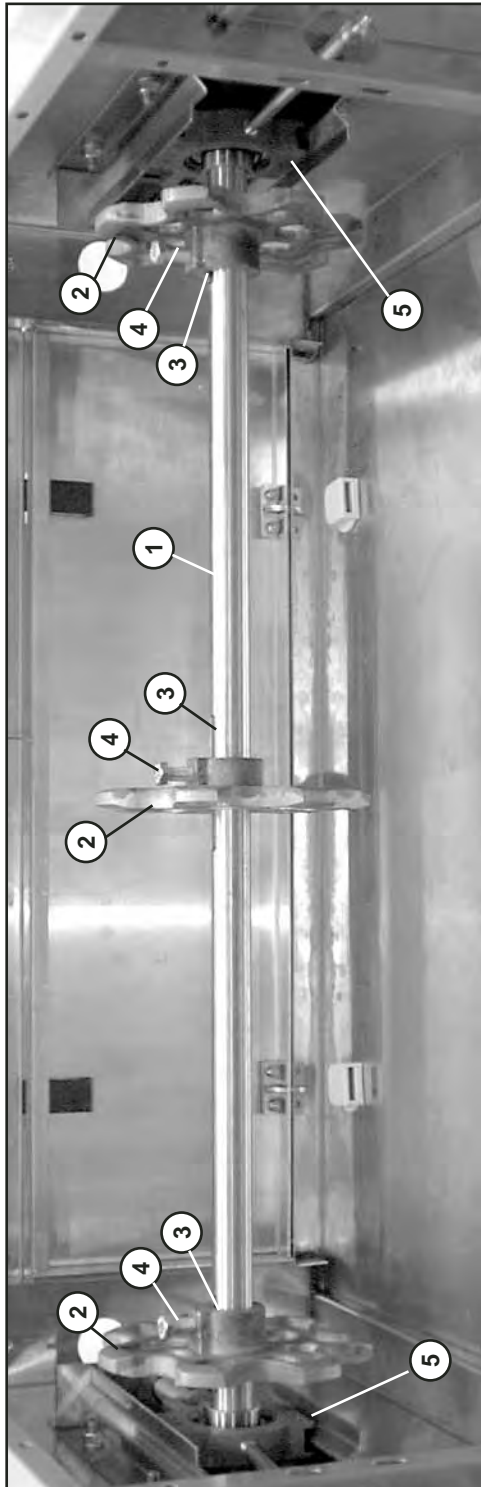

Figure 32 - Drive Shaft Assembly

DRIVE SHAFT ASSEMBLY

Fig. 32 Item No.	Part No.	Part Description	Qty.
1	112244	Shaft, Idle	1
2	108434	Sprocket, Conveyor Belt	3
3	107305	Key (1/4 x 1/4 x 1-1/2).....	A/R
4	111480	Bolt, Sprocket Retaining (3/8-16 x 3/4).....	A/R
5	403980	Take-up Assembly.....	2
7	112243	Shaft, Drive	1
8	108434	Sprocket, Conveyor Belt	3
9	107305	Key (1/4 x 1/4 x 1-1/2).....	A/R
10	111480	Bolt, Sprocket Retaining (3/8-16 x 3/4).....	A/R
11	109958	Bearing, Drive	2
12	109388	Shock Absorber (Located on drive shaft) (Not Shown)	2

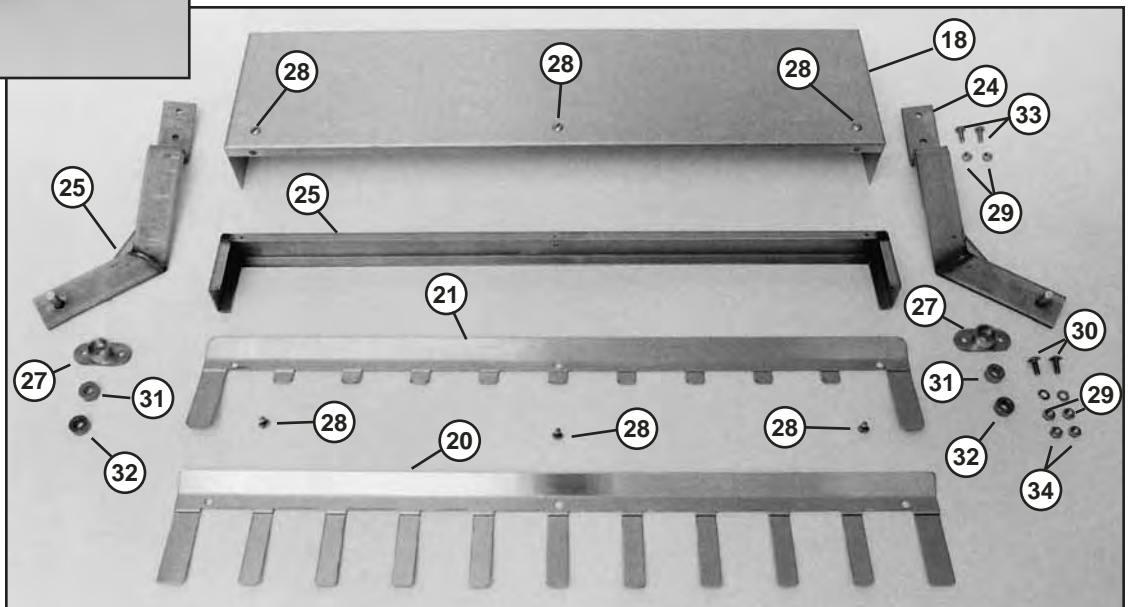
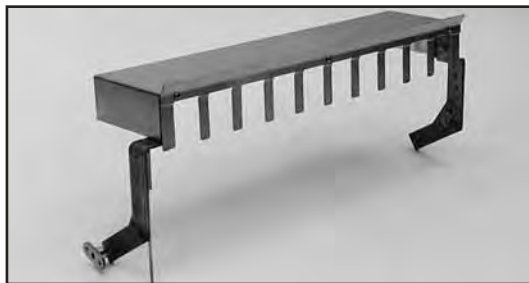
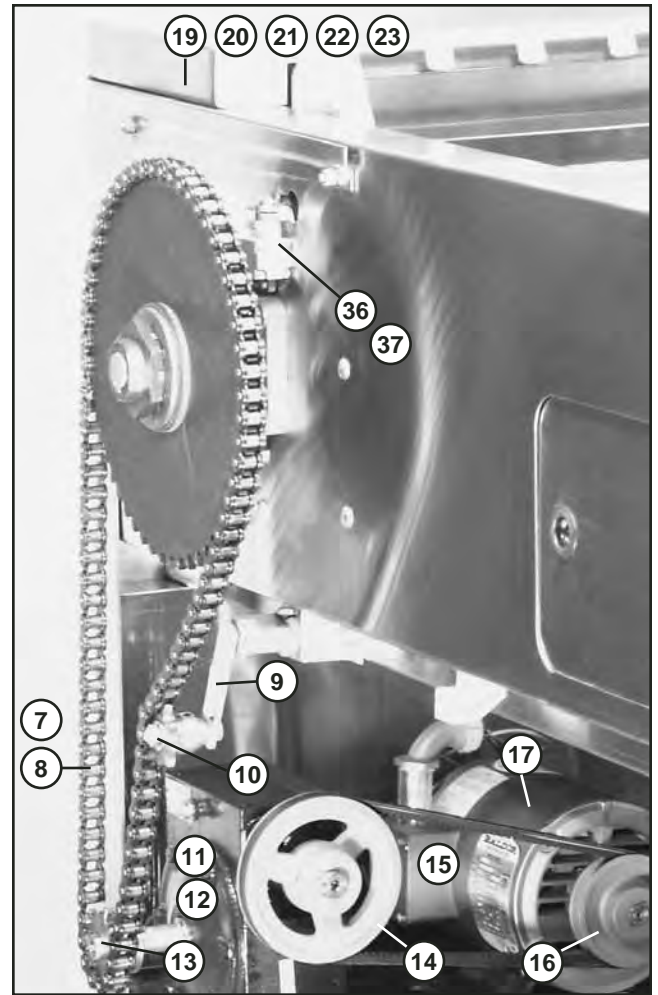
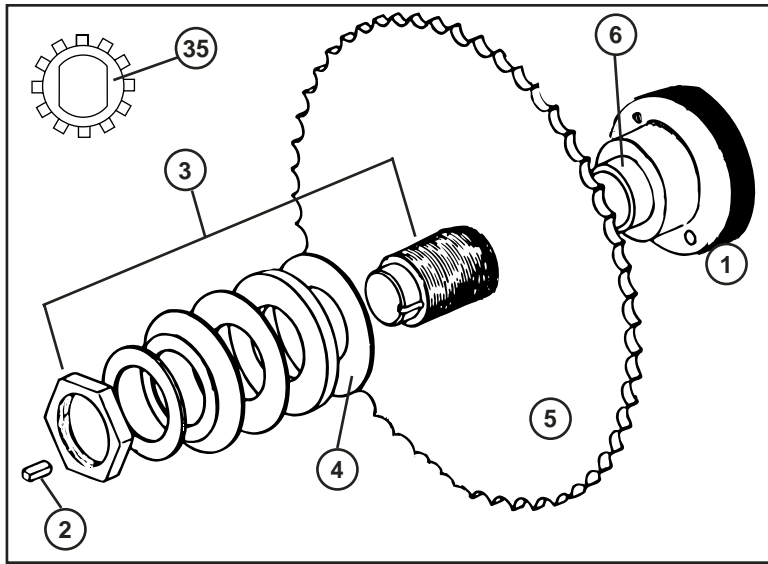

Figure 33 - Conveyor Drive and Shut-off Assembly

CONVEYOR DRIVE AND SHUT-OFF ASSEMBLY

Fig. 33 Item No.	Part No.	Part Description	Qty.
1	109958	Bearing, Drive	2
2	106679	Key (1/4 x 1/4 x 2-1/2).....	1
3	100485	Clutch, Torque Limiter (Complete Assembly)	1
4	102315	Clutch Disc Assembly (Complete Set #350)	1
5	108013	Sprocket, Drive.....	1
6	104271	Bushing (.54" Long for Torque Limiter Clutch).....	2
7	101156	Chain (#50 5/8" Steel).....	5
8	101149	Link, Connecting.....	1
9	110076	Tensioner, Chain.....	1
10	106521	Sprocket, Idler	1
11	110299	Gearbox, RH w/Bracket	1
12	110300	Gearbox, LH w/Bracket	1
13	105285	Sprocket, Gearbox (11T).....	1
14	103174	Sheave, Gearbox (C6)	1
14	108088	Sheave, Gearbox (C8)	1
14	100451	Sheave, Gearbox (C8 w/Optional Water Saver)	1
14	100454	Sheave, Gearbox (C6 w/Optional Water Saver)	1
15	100794	V-Belt (C8, C8 w/Optional Water Saver)	1
15	100795	V-Belt (C6, C6 w/Optional Water Saver, C6 VSPD*).....	1
15	100792	V-Belt (C6 VSPD*, C8 VSPD).....	1
16	107615	Sheave, Motor (C6, C8)	1
16	100451	Sheave, Motor (C8 w/Optional Water Saver)	1
16	108212	Sheave, Motor (C6 w/Optional Water Saver)	1
17	107183	Motor, 1/2 HP (208-240/480V/60/3PH)	1
17	110207	Motor, 1/2 HP (208-240/480V/60/3PH) VSPD.....	1
17	180230	Motor, 1/2 HP (575/60/3PH).....	1
17	180256	Motor, 1/2 HP (380V/50/3PH).....	1
17	180038	Motor, 3/4 HP (208-240/480V/60/3PH)	1
18	309738	Cover, Conveyor Shut-off	1
19	309719	Finger, Short Conveyor Shut-off (Standard Belt w/upper rod).....	1
20	309718	Finger, Long Conveyor Shut-off (Standard Belt w/o upper rod)	1
21	309555	Finger, Conveyor Shut-Off (Silverware Belt) (Not Shown)	1
22	314596	Finger, Conveyor Shut-Off (Combination long/short) (Not Shown)	1
23	315970	Finger, Conveyor Shut-Off (Insulated tray belt) (Not Shown) ..	1
24	316369	LH Assembly, Conveyor Shut-Off	1
25	316370	RH Assembly, Conveyor Shut-Off.....	1
26	316367	Top, Conveyor Shut-Off.....	1
27	202393	Flange Seal	2
28	100007	Screw (10-32 x 3/8 Truss Head)	6
29	106482	Washer Lock 1/4 Split.....	8
30	100779	Screw (1/4-20 x 5/8 Truss Head)	4
31	104266	Bushing (3/8 x 3/4 x 3/8 Bronze)	2
32	104586	Collar (3/8" SST)	2
33	100735	Bolt (1/4-20 x 5/8 Hex Head)	4
34	100141	Nut, Grip (1/4-20 SST)	4
35	107700	Lockwasher, Tab.....	1
36	111090	Hamlin Reed Switch	1
37	111026	Magnet SST.....	1

* Denotes Variable Speed Drive/Dc Drive Systems

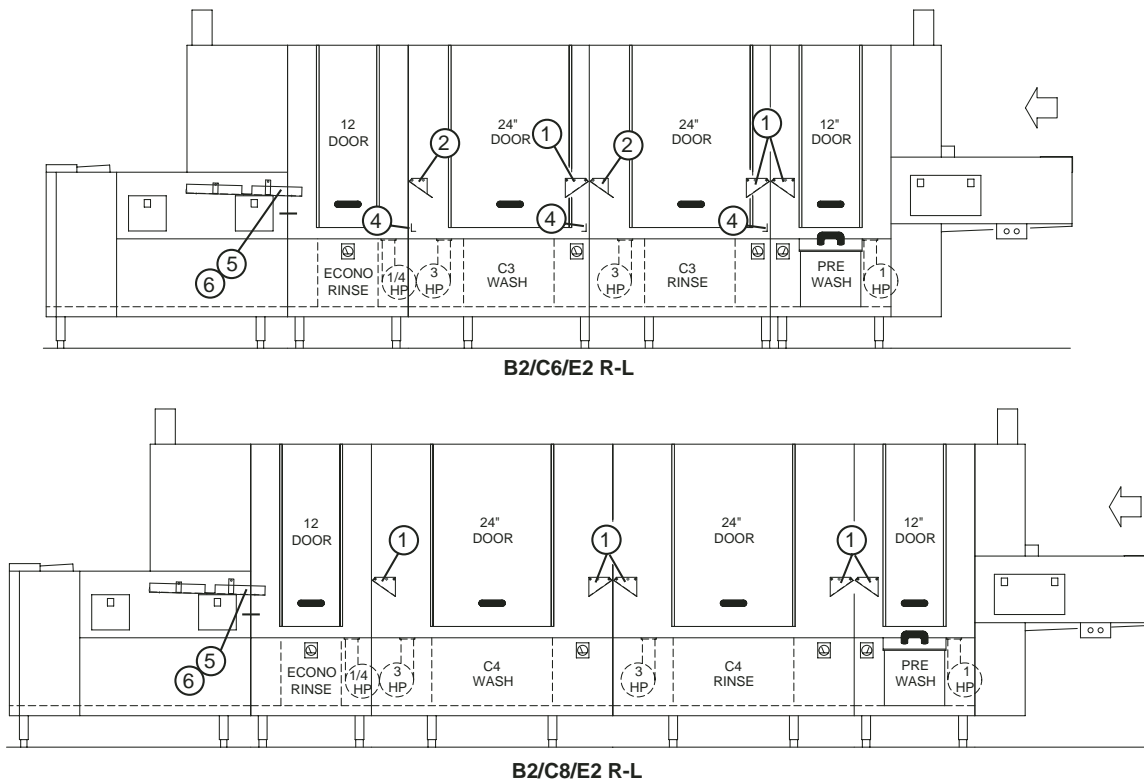

Figure 34 - Baffles (R-L Direction Shown)

UC/CW BAFFLE SYSTEM

Fig. 34 Item No.	Part No.	Part Description	Qty.
1	322108	Baffle Development (Prewash, Wash, Rinse)	A/R
2	324394	Baffle Development (C3, LH only)(See Note *)	A/R
3	111045	Elbow 1/2" x 45 PVC NPT (All Fill Sections).....	A/R
4	306586-30	Lower Baffle (See Note Below**).....	A/R
5	322110	Baffle Weldment (RH Final Rinse).....	1
6	322113	Baffle Weldment (LH Final Rinse).....	1
7	100007	Screw 10-32 x 3/8 Truss Head.....	2
8	107966	Nut, Grip 10-32 w/Nylon Insert.....	1
9	106482	Washer, Lock 1/4.....	2
10	100734	Bolt 1/4-20 x 1/2" Hex Head.....	2

Notes:

* Baffle used on the left hand side of the door on all C3 tanks Wash or Rinse Sections

** 306586-30 is used on C3 and C6 sections at every break that joins a C3 Section

All B4 Sections should take a baffle on each end of the section.

CONVEYOR BELTS

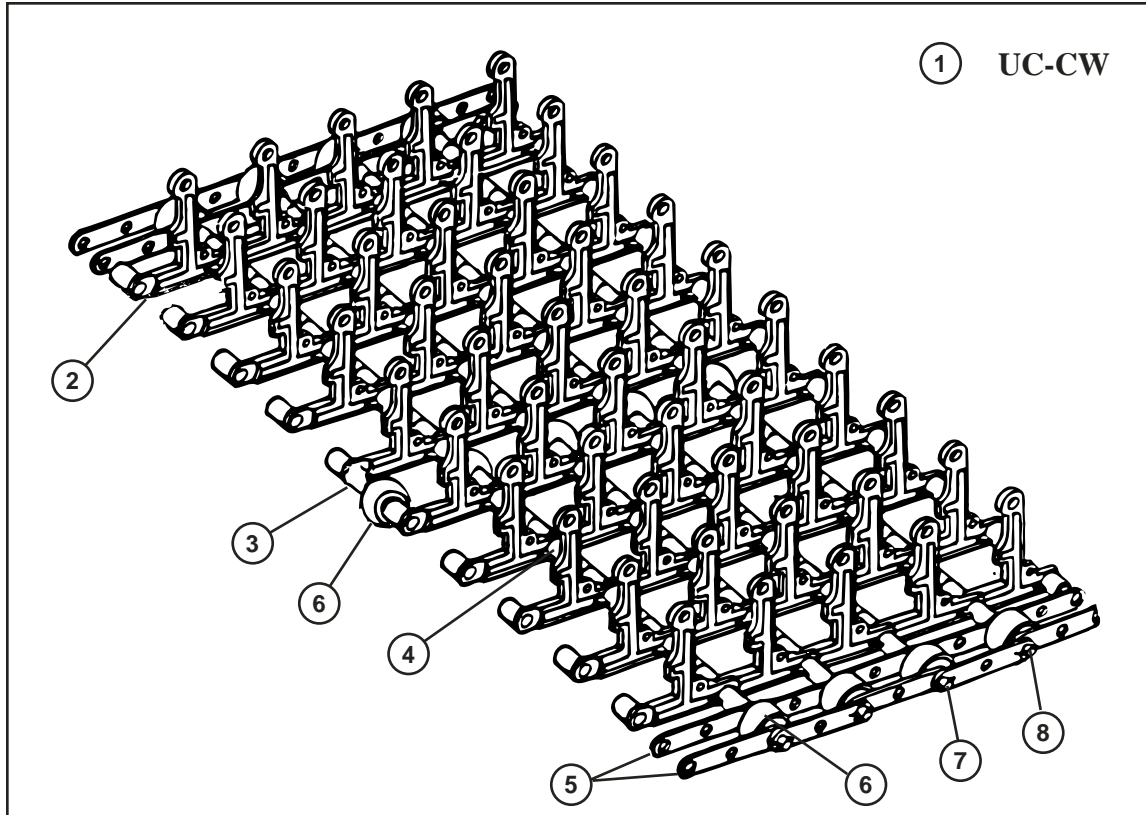

Figure 35 - Peg Belt

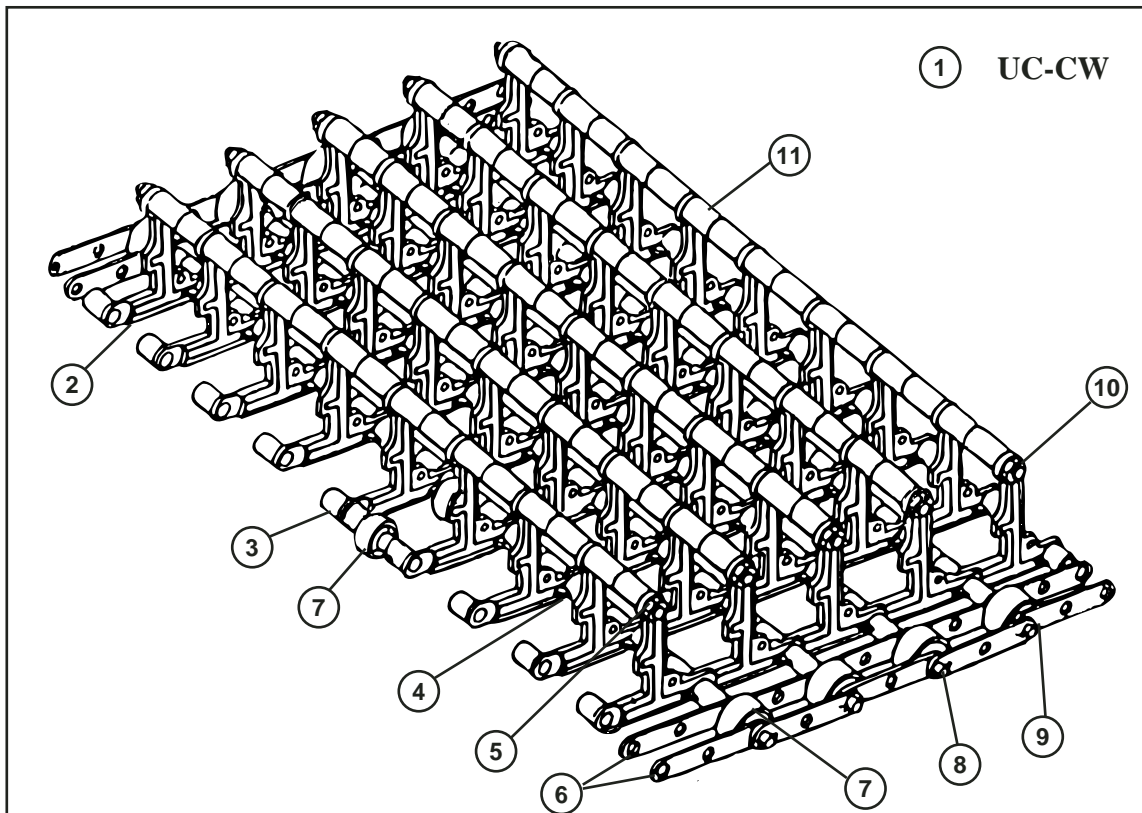

Figure 36 - Peg Belt with Upper Rod

UC-CW PEG BELT

Note 1: Total number of Rod Sections required for belt replacement vary depending on Machine Length.

Note 2: Quantities listed below are per one (1) ROD SECTION.

Fig. 35 Item No.	Part No.	Part Description	Qty.
1	404104	Rod Section, Peg Belt, UC-CW	A/R
2	110092	Link, Upright.....	10
3	108378	Spacer (11/32 x 5/16).....	2
4	108438	Spacer (11/32 x 1-13/32)	8
5	108435	Link, Straight End, Stainless Steel	4
6	108437	Roller, Plastic	3
7	108875	Pin, Cotter	2
8	108381	Rod, Drilled Stainless Steel (5/16 x 29-1/4).....	1

UC-CW PEG BELT with UPPER ROD

Note 1: Total number of Rod Sections required for belt replacement vary depending on Machine Length.

Note 2: Quantities listed below are per one (1) ROD SECTION.

Fig. 36 Item No.	Part No.	Part Description	Qty.
1	404106	Rod Section, Peg Belt w/ Upper Rod, UC-CW	A/R
2	110092	Link, Upright.....	10
3	108378	Spacer (11/32 x 5/16).....	2
4	108438	Spacer (11/32 x 1-13/32)	8
5	100141	Nut, Grip (1/4-20 SST)	2
6	108435	Link, Straight End, Stainless Steel	4
7	108437	Roller, Plastic	3
8	108875	Pin, Cotter	2
9	108381	Rod, Drilled Stainless Steel (5/16 x 29-1/4).....	1
10	202601	Rod, Threaded Stainless Steel (1/4 x 26).....	1
11	108439	Spacer (1/2 x 9/32 x 2-9/16)	9

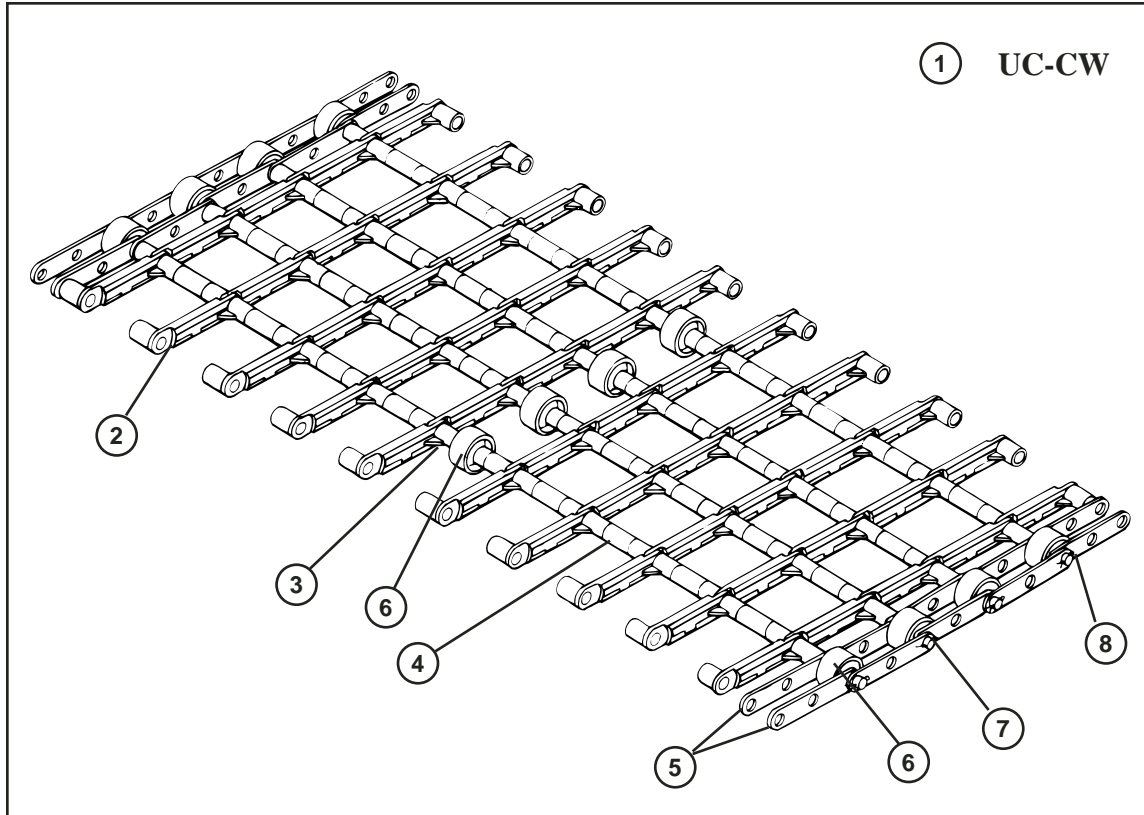

Figure 37 - Flat Belt

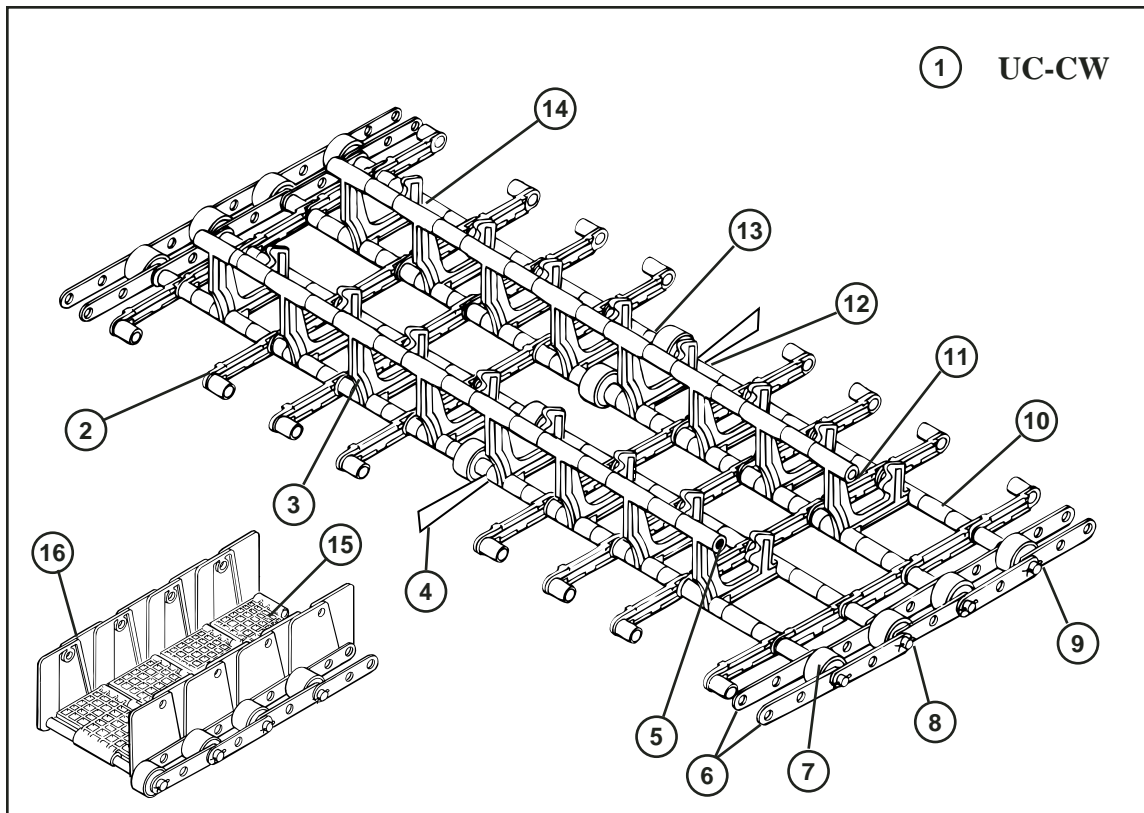

Figure 38 - Insulated Tray Belt (Silverware Belt Optional)

UC-CW FLAT BELT

Note 1: Total number of Rod Sections required for belt replacement vary depending on Machine Length.

Note 2: Quantities listed below are per two (2) ROD SECTIONS.

Fig. 37 Item No.	Part No.	Part Description	Qty.
1	402237	TWO Rod Sections, Flat Belt, UC-CW	A/R
2	110094	Link, Flat	20
3	108378	Spacer (11/32 x 5/16)	6
4	108438	Spacer (11/32 x 1-13/32)	16
5	108435	Link, Straight End, Stainless Steel	8
6	108437	Roller, Plastic	6
7	108875	Pin, Cotter	4
8	108381	Rod, Drilled Stainless Steel (5/16 x 29-1/4)	2

UC-CW INSULATED TRAY BELT

Note 1: Total number of Rod Sections required for belt replacement vary depending on Machine Length.

Note 2: Quantities listed below are per two (2) ROD SECTIONS.

Fig. 38 Item No.	Part No.	Part Description	Qty.
1	402238	TWO Rod Sections, Insulated Tray Belt, UC-CW	A/R
2	110094	Link, Flat	16
3	109030	Link, Upright Poly	8
4	204995	Link, Flat Modified	1
5	100141	Nut, Grip (1/4-20 SST)	2
6	108435	Link, Straight End, Stainless Steel	8
7	108437	Roller, Plastic	6
8	108875	Pin, Cotter	4
9	108381	Rod, Drilled Stainless Steel (5/16 x 29-1/4)	2
10	109282	Spacer (11/32 x 1-1/32)	4
11	109224	Rod, Threaded Stainless Steel (1/4 x 22-1/4)	1
12	102376	Washer (5/16 x 3/4 x 1/16)	2
13	108378	Spacer (11/32 x 5/16)	2
14	109187	Spacer (9/32 x 1-13/32)	7
SILVERWARE BELT			
15	109164	Link, Flat, Silverware Belt	2
16	109163	Link, Side, Silverware Belt	4

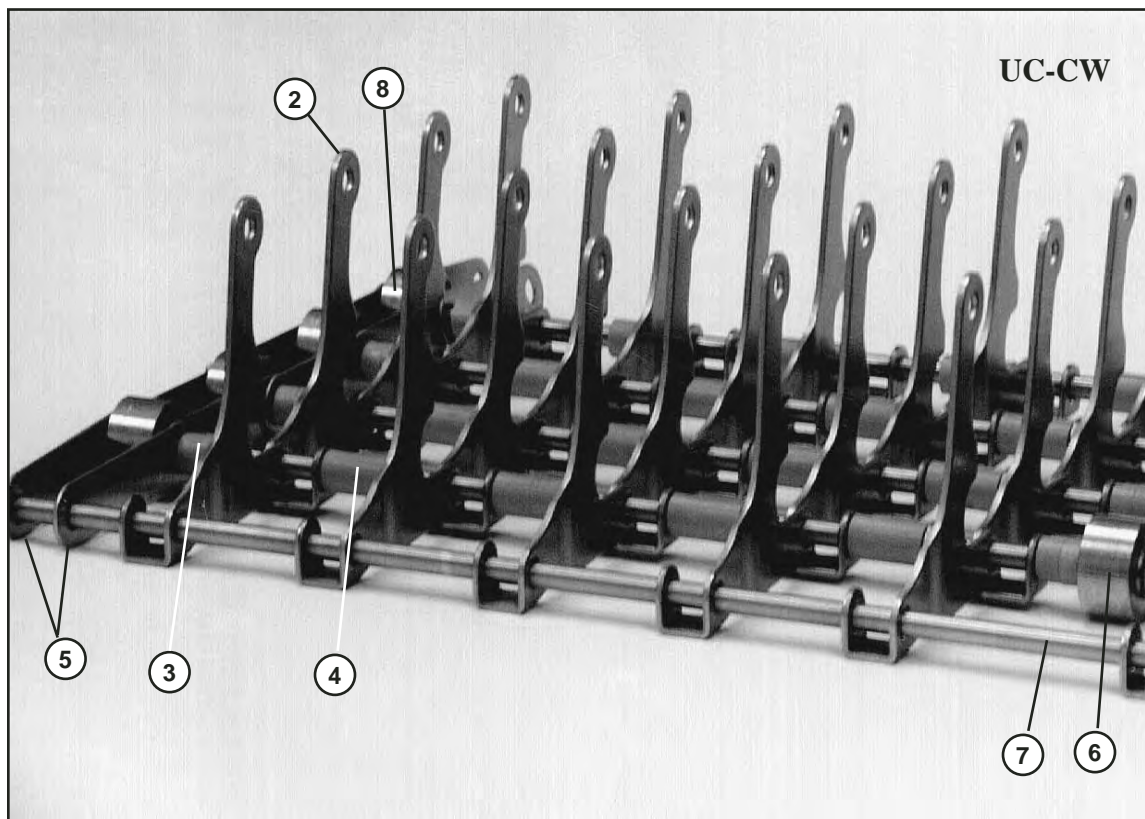

Figure 39 - Stainless Steel Peg Belt

UC-CW STAINLESS STEEL PEG BELT

Note 1: Total number of Rod Sections required for belt replacement vary depending on Machine Length.

Note 2: Quantities listed below are per one (1) ROD SECTION.

Fig. 39 Item No.	Part No.	Part Description	Qty.
1	408013	Rod Section, Stainless Steel Peg Belt, UC-CW	A/R
2	111421	Link, Stainless Steel Upright	10
3	109282	Spacer (11/32 x 1-1/32)	8
4	108378	Spacer (11/32 x 5/16).....	8
5	108435	Link, Straight End, Stainless Steel	4
6	108375	Roller, Stainless Steel.....	3
7	108381	Rod, Drilled Stainless Steel (5/16 x 29-1/4).....	1
8	108875	Pin, Cotter (Not Shown).....	2

UC-CW Stainless Steel Peg Belt with Upper Rod

(Items 2 thru 8 above and the Parts Listed Below)

—	100141	Nut, Grip (1/4-20 SST) (Not Shown)	2
—	202601	Rod, Threaded (1/4 x 26) (Not Shown).....	1

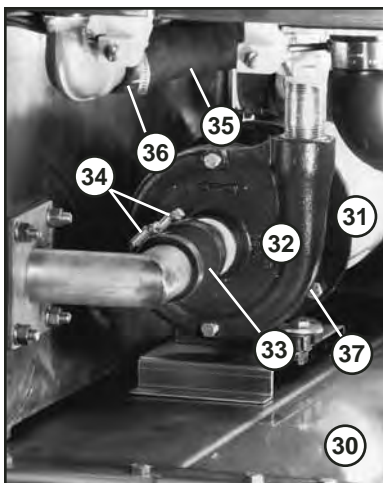
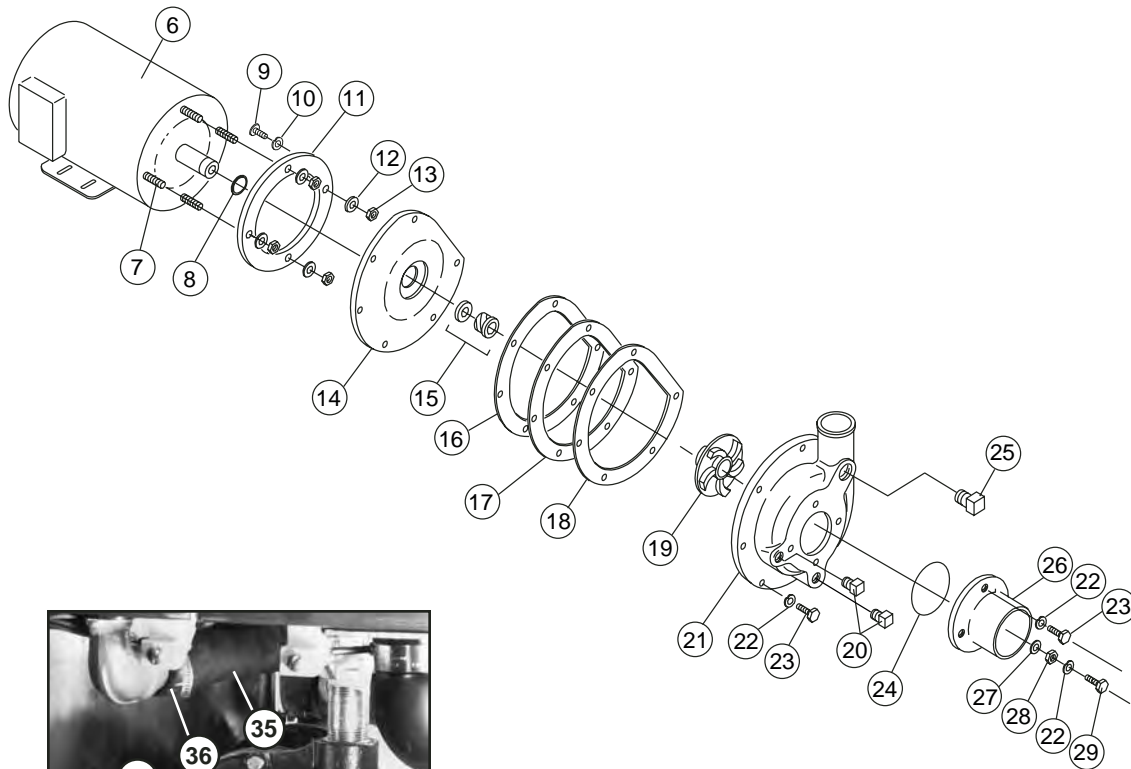
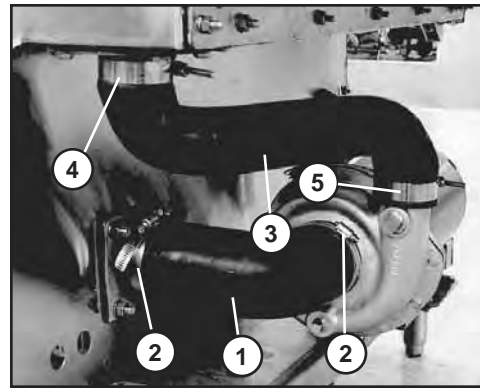
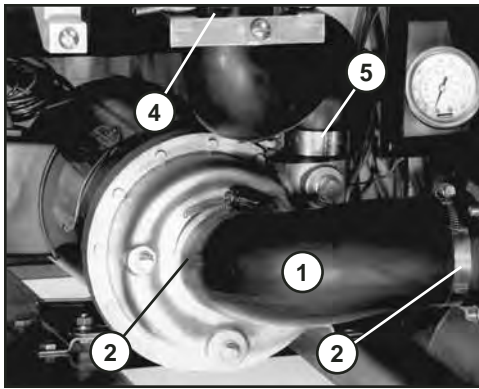

See bottom of Page 68 for
Optional EconoRinse Pump parts

Figure 40 - Pump Assembly

PUMP ASSEMBLY

Fig. 40 Item No.	Part No.	Part Description	Qty.
1	110372	Hose, Pump Suction	1
2	104203	Clamp, Suction Hose.....	2
3	112409	Hose, Pump Discharge	1
4	110858	Clamp, Discharge Hose (Standpipe side)	1
5	111964	Clamp, Discharge Hose.....	1
6	110420	Motor, 1 HP Prewash (208-240V/460V/60/3PH).....	1
6	180245	Motor, 1 HP Prewash (380V/50/3PH)	1
6	180272	Motor, 1 HP Prewash (380V/60/3PH)	1
6	180237	Motor, 1 HP Prewash (415/50/3PH)	1
6	111739	Motor, 1 HP Prewash (575V/60/3PH)	1
6	180210	Motor, 1 HP Prewash (600V/60/3PH)	1
6	180212	Motor, 1 HP Prewash (220V/50/3PH)	1
6	110422	Motor, 2 HP Prewash (208-240V/460V/60/3PH).....	1
6	180226	Motor, 2 HP Prewash (380V/50/3PH)	1
6	180273	Motor, 2 HP Prewash (380V/60/3PH)	1
6	180246	Motor, 2 HP Prewash (415V/50/3PH)	1
6	111740	Motor, 2 HP Prewash (575V/60/3PH)	1
6	110424	Motor, 3 HP Prewash, Wash/Rinse (208-240/460V/60/3PH)....	1
6	111741	Motor, 3 HP Prewash, Wash/Rinse (575V/60/3PH)	1
6	180239	Motor, 3 HP Prewash, Wash/Rinse (415V/60/3PH)	1
6	180257	Motor, 3 HP Prewash, Wash/Rinse (380V/50/3PH)	1
7	110734	Stud, Motor	1
8	109654	Slinger, Water	1
9	100754	Screw, 10-32 x 1/2" Flat Head	1
10	110270	Washer, Star Countersunk	1
11	204460	Plate, Backing	1
12	106407	Washer, Lock.....	1
13	107690	Nut, Jam 3/8-16.....	1
14	111681	Flange, Pump.....	1
15	111111	Seal, Shaft	1
16	111941	Gasket (.0085") (1 Notch).....	1
17	111942	Gasket (.015") (2 Notches)	1
18	111943	Gasket (.032") (3 Notches)	2
19	113118	Impeller, SST (2.875") 1 HP.....	1
19	113119	Impeller, SST (3.5") 2 HP.....	1
19	113120	Impeller, SST (4.0") 3 HP.....	1
20	102500	Plug, 1-1/4" NPT Brass.....	2
21	112380	Volute, Pump	1
22	106482	Washer, Lock 1/4" Split	11
23	100736	Bolt, 1/4-20 x 3/4" Hex Head	10
24	112338	O-Ring Gasket, Pump Suction Flange	1
25	102504	Plug, 1/2" NPT Brass	1
26	112379	Flange, Suction.....	1
—	112338	Gasket-Pump, Suction.....	1

PUMP ASSEMBLY (CONT.)

Fig. 40 Item No.	Part No.	Part Description	Qty.
27	110248	Washer, Flat.....	1
28	110247	Nut, Hex Jam 7/16-20.....	1
29	100734	Bolt, 1/4-20 x 1/2" Hex Head.....	1
—	405919	Motor/Pump Assy. (Complete) 1 HP Prewash (208-240/480V/60/3PH)	
—	405920	Motor/Pump Assy. (Complete) 2 HP Prewash (208-240/480V/60/3PH)	
—	405921	Motor/Pump Assy. (Complete) 3 HP Prewash (208-240/480V/60/3PH)	
—	405922	Motor/Pump Assy. (Complete) 3 HP C3 Section - Wash/Rinse (208-240/480V/60/3PH)	
—	405923	Motor/Pump Assy. (Complete) 3 HP C4 Section - Wash/Rinse (208-240/480V/60/3PH)	

ECONORINSE SECTION OPTION

Fig. 40 Item No.	Part No.	Part Description	Qty.
30	180280	Motor/Pump Assy. (Complete) 1/4 HP (208-240/460V/60/3PH).....	1
31	180327	Motor, 1/4 HP (208-240/460V/60/3PH) EconoRinse.....	1
32	900728	Pump Assembly (Less Motor).....	1
33	205202	Hose, Suction (1-5/8 I.D. x 4-3/4).....	1
34	107340	Clamp, Suction Hose.....	2
35	205201	Hose, Discharge (1-3/8 I.D. x 9-1/2).....	1
36	107340	Clamp, Discharge Hose.....	2
37	180326	Bolt (Pump to Motor).....	4
—	108598	Gasket, Pump (Not Shown).....	1
—	180325	Seal, Shaft (Not Shown).....	1
—	112106	Impeller, 1/4 HP EconoRinse Pump (Not Shown).....	1
—	112107	Volute (Not Shown).....	1
—	900756	Kit*Volute, Impeller, Repair Kit (Not Shown)	
—	900757	Repair Kit w/Seal, (Pump Gasket, Pump Shaft w/set screws, Water Slinger, Shaft Seal)	

ELECTRIC TANK HEAT

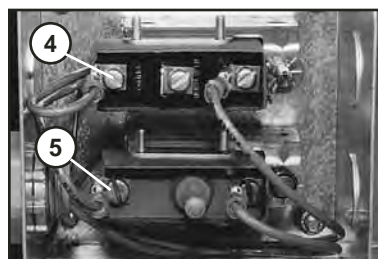
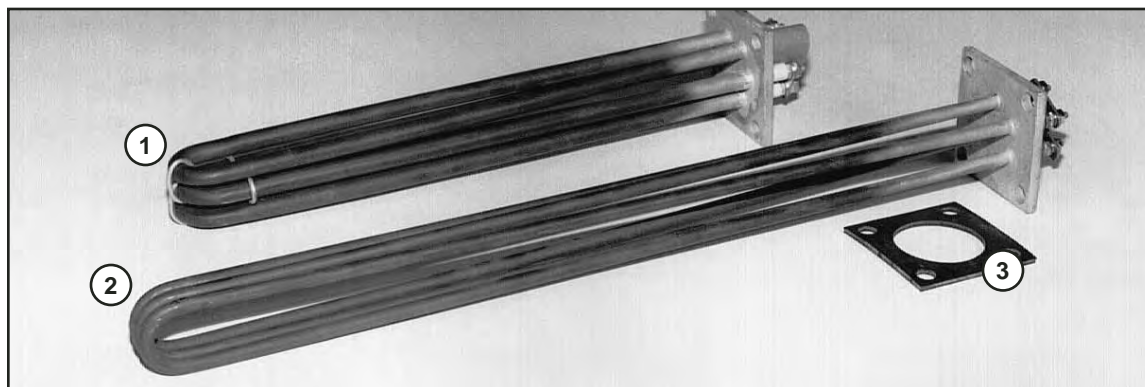
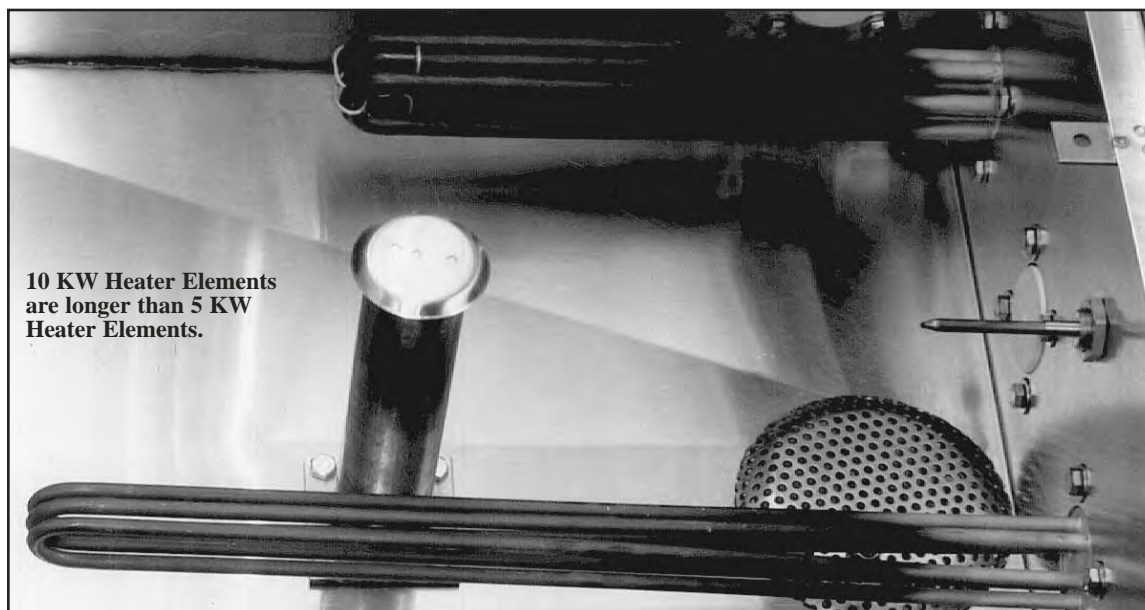

Figure 41 - Electric Tank Heat

ELECTRIC TANK HEAT

Fig. 41 Item No.	Part No.	Part Description	Qty.
1	107839	Element, Tank Heater (5KW, 208V/3PH).....	A/R
1	107840	Element, Tank Heater (5KW, 240V/3PH).....	A/R
1	107842	Element, Tank Heater (5KW, 480V/3PH).....	A/R
1	111123	Element, Tank Heater (5KW, 575V/3PH).....	A/R
2	109751	Element, Tank Heater (10KW, 208V/3PH).....	A/R
2	107844	Element, Tank Heater (10KW, 240V/3PH).....	A/R
2	107846	Element, Tank Heater (10KW, 480V/3PH).....	A/R
2	111120	Element, Tank Heater (10KW, 575V/3PH).....	A/R
3	108345	Gasket, Tank Heater (one per element).....	A/R
4	109069	Thermostat, Control (one per tank).....	1
5	110561	Thermostat, High Limit (one per tank).....	1

ECONORINSE SECTION (Optional)

Fig. 41 Item No.	Part No.	Part Description	Qty.
—	111258	Element, Tank Heater (15KW, 208V/3PH).....	A/R
—	111259	Element, Tank Heater (15KW, 240V/3PH).....	A/R
—	111260	Element, Tank Heater (15KW, 480V/3PH).....	A/R
—	—	Element, Tank Heater (15KW, 575V/3PH).....	A/R
3	108345	Gasket, Tank Heater (one per element).....	A/R
4	109069	Thermostat, Control (one per tank).....	A/R
5	110561	Thermostat, High Limit (one per tank).....	A/R

**THIS PAGE
INTENTIONALLY
LEFT BLANK**

STEAM TANK HEAT

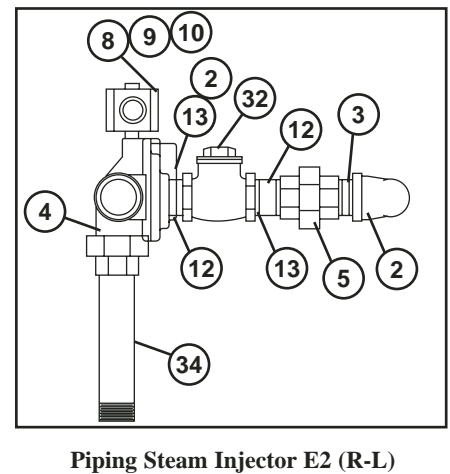
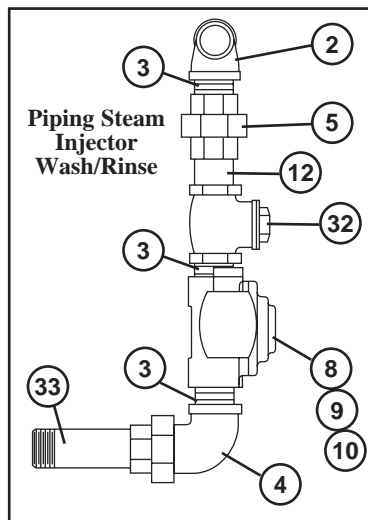
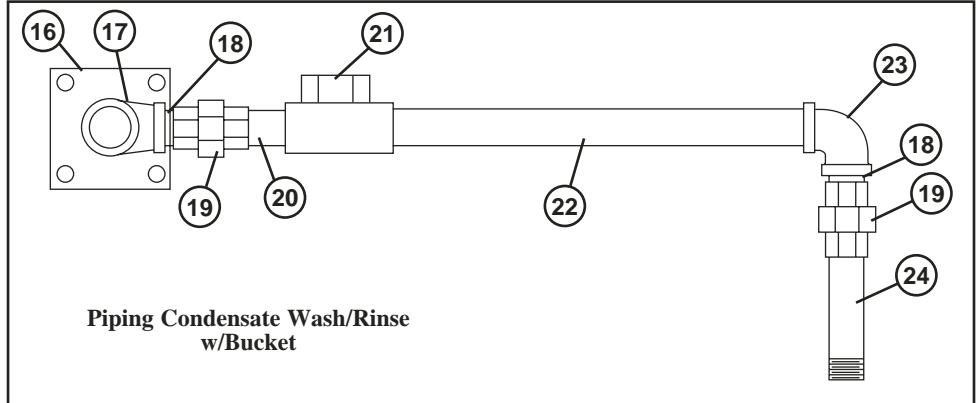
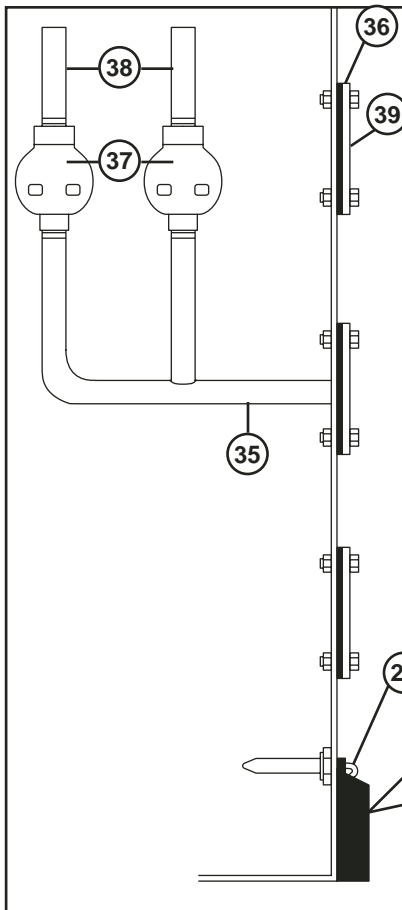
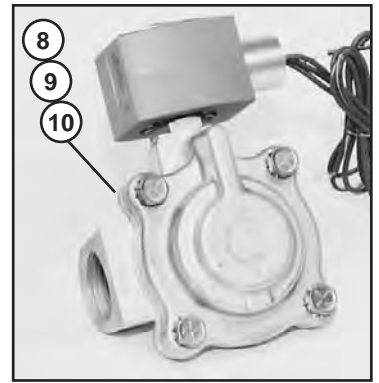
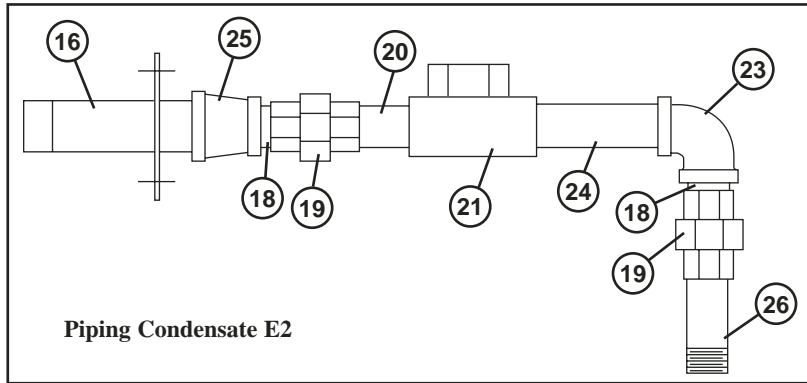
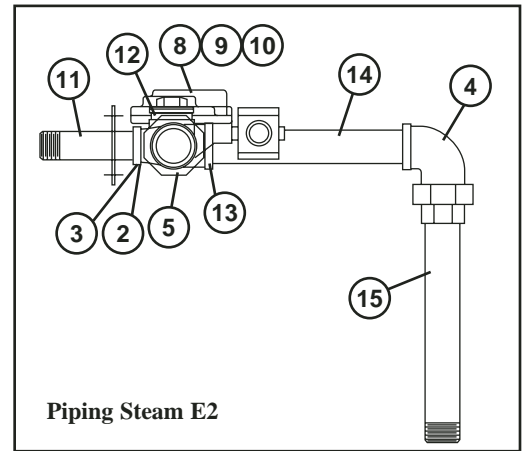
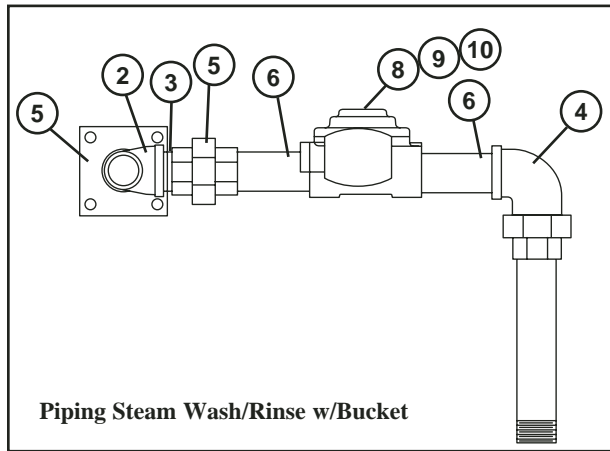

Figure 42 - Steam Tank Heat

STEAM TANK HEAT			
Fig. 42 Item No.	Part No.	Part Description	Qty.
1	323828	Flange Weldment (C3 Section)	1
1	323007	Flange Weldment (C4 Section)	1
2	105739	Elbow, Red. 1" NPT x 3/4" NPT BI	1
3	105847	Nipple Close 1" NPT BI	1
4	107211	Union Elbow, 1" NPT x 90° Female BI.....	1
5	105780	Union 1" NPT BI	1
6	109969	Nipple, 1" NPT x 3 3/4" LG BI	2
7	105864	Nipple, 1" NPT x 7" LG BI	1
8	110005	Valve Steam Solenoid (1" Asco).....	1
9	110007	Repair Kit (1" Asco)	1
10	110120	Coil, Solenoid (1" Asco).....	1
11	323007	Flange Weldment (E2 Section)	1
12	105850	Nipple, 1" NPT x 2" LG BI	1
13	105733	Elbow, 1" NPT x 90° BI	1
14	105867	Nipple, 1" NPT x 8 1/2" LB BI	1
15	106840	Nipple, 1" NPT x 9" LG BI	1
16	323829	Flange Weldment (C3 Section)	1
16	323007	Flange Weldment (C4 Section) (E2 Section).....	1
17	105738	Elbow, Red. 3/4" NPT x 1/2" NPT BI	1
18	105782	Nipple, Close 1/2" NPT BI	2
19	105778	Union 1/2" NPT BI	1
20	105783	Nipple, 1/2" NPT x 2" LG BI	1
21	111380	Steam Trap 1/2".....	1
22	109580	Nipple, 1/2" NPT x 11" LG BI	1
23	102288	Elbow 1/2" NPT x 90° BI.....	1
24	107488	Nipple, 1/2" NPT x 3 1/2" LG BI.....	1
25	105723	Coupling, Red 3/4" NPT x 1/2" NPT BI	1
26	105785	Nipple, 1/2" NPT x 2 1/2" LG BI.....	1
27	109069	Thermostat, Control	1
28	321000	Cover, Heater Box (C3 Section w/o Refuse Bucket).....	1
28	322626	Cover, Heater Box (C4 Section w/o Refuse Bucket).....	1
28	322812	Cover, Heater Box (E2 Section w/o Refuse Bucket).....	1
29	322625	Heater Box Weld (C4 Section w/o Refuse Bucket).....	1
29	320998	Heater Box Weld (C3 Section w/o Refuse Bucket).....	1
29	311811	Heater Box Weld (E2 Section w/o Refuse Bucket).....	1
30	314102	Dual Thermostat Box	1
31	109682	Cover (Box).....	1
32	100854	Valve, Check 1" NPT	1
33	105856	Nipple, 1" NPT x 4" LG BI	1
34	106606	Nipple, 1" NPT x 6" LG BI	1
35	324447	Manifold, Weld Steam Injector (C3 Section)	1
35	309440	Manifold, Weld Steam Injector (C4 Section)	1
35	324448	Manifold, Weld Steam Injector (E2 Section).....	1
36	108345	Gasket, 3 x 3 x 1/8".....	A/R
37	201110	Injector, Steam	1
38	111371	Nipple, Toe 1" x 7" SST	1
39	109683	Flange.....	A/R

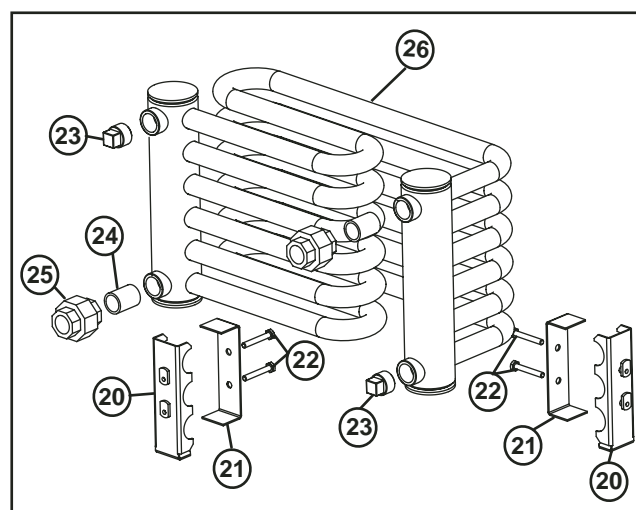
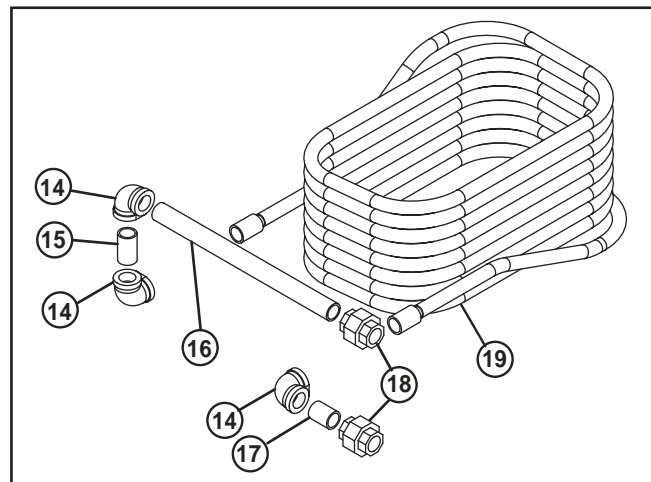
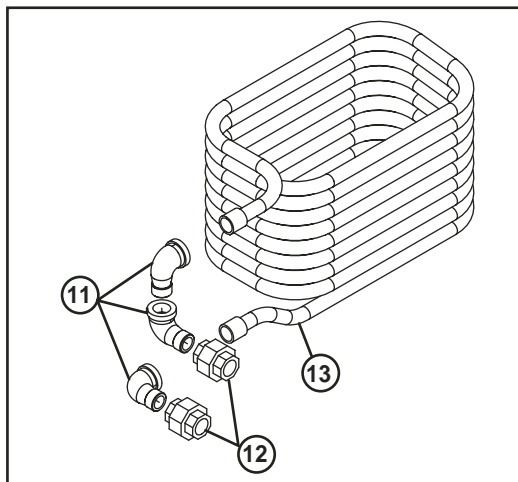
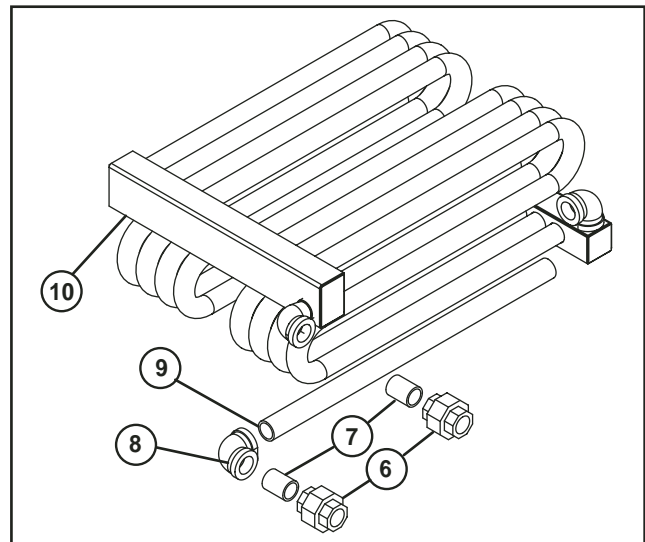
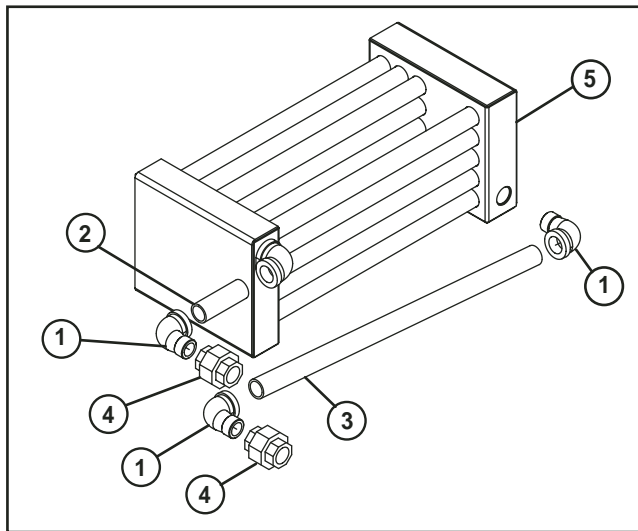

Figure 43
Steam Coils (Low Pressure, Standard/High Pressure, EconoRinse)

LOW PRESSURE STEAM COILS

Fig. 43 Item No.	Part No.	Part Description	Qty.
1	100023	Street Elbow 3/4" NPTSST	3
2	101090	Nipple 3/4" NPT x 3" LG SST	1
3	101589	Nipple 3/4" NPT x 19-3/4" LG SST.....	1
4	102554	Union 4/4" NPT SST	2
5	323830	Coil Weldment Steam C3 (Low Pressure).....	1
6	102554	Union 3/4" NPT SST	2
7	100051	Nipple 3/4" NPT x Close SST	2
8	102443	Elbow 3/4" NPT x 90° SST.....	1
9	112890	Nipple 3/4" NPT x 18-3/4" LG SST.....	1
10	323809	Coil Weldment Steam C4 (Low Pressure).....	1

STANDARD AND HIGH PRESSURE STEAM COILS

Fig. 43 Item No.	Part No.	Part Description	Qty.
11	100023	Street Elbow 3/4" NPT SST.....	3
12	102554	Union 3/4" NPT SST	2
13	323862	Coil Weldment Steam (C3 Section, Wash/Rinse).....	1
14	102443	Elbow 3/4" x 90° SST	3
15	100959	Nipple 3/4" x 1-3/4" SST.....	1
16	101558	Nipple 3/4" x 13-3/4" SST.....	1
17	100051	Nipple Close 3/4" SST.....	1
18	102554	Union 3/4" NPT SST	2
19	307384	Coil Weldment Steam (C4 Section, Wash/Rinse).....	1

ECONORINSE STEAM COILS

Fig. 43 Item No.	Part No.	Part Description	Qty.
20	326855	Bracket, Steam Coil Weldment.....	2
21	325629	Cap, Steam Coil Bracket.....	2
22	107999	Cap, Screw 1/4-20 x 1-3/4 Hex Head SST	4
23	102506	Plug 3/4" NPT SST	2
24	100051	Nipple Close 3/4" NPT SST	2
25	102554	Union 3/4" NPT SST	2
26	325545	Coil Weldment Steam (E2 Section, EconoRinse).....	1

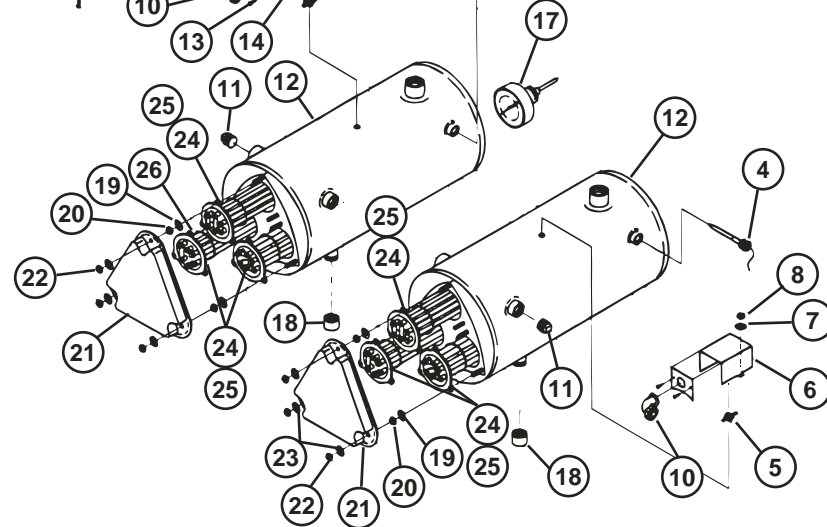
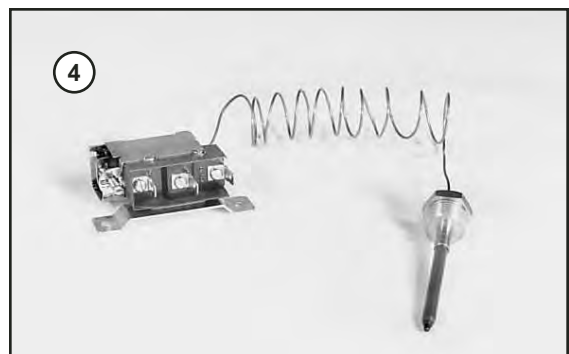
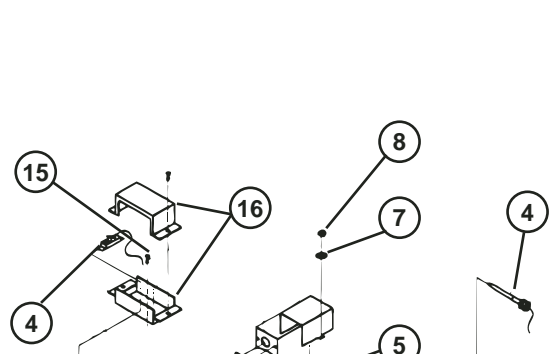

Figure 44 - Electric Booster

ELECTRIC BOOSTER

Fig. 44 Item No.	Part No.	Part Description	Qty.
1	109887	Valve, Solenoid (3/4").....	1
—	109903	Repair Kit, Solenoid Valve (3/4").....	1
—	108516	Coil, Solenoid Valve (3/4").....	1
2	109886	Valve, Solenoid (1/2") (Prior to S/N J1533).....	A/R
—	109902	Repair Kit, Solenoid Valve (1/2") (Prior to S/N J1533).....	1
—	108516	Coil, Solenoid Valve (1/2") (Prior to S/N J1533).....	1
2	113352	Valve, Solenoid (1/2") (After S/N J1534).....	A/R
—	113392	Repair Kit, Solenoid Valve (1/2") (After S/N J1534).....	1
—	113357	Coil, Solenoid Valve (1/2") (After S/N J1534).....	1
3	107550	Valve, Pressure Reducing (3/4").....	1
4	109069	Thermostat, Control (one per tank).....	A/R
5	110562	Thermostat, High Limit (one per tank).....	A/R
6	110929	Box, High Limit Thermostat (one per tank).....	A/R
7	107033	Washer, Flat #10.....	2
8	107966	Nut, Grip (10-32 w/ Nylon Insert).....	2
9	110930	Cover, Box, High Limit Thermostat (one per tank).....	A/R
10	103217	Connector, Sealtite Elbow (1/2 x 90°).....	1
11	102505	Plug, Brass (3/4 NPT).....	1
*12	305407	Tank, Booster (Specify Model Number of Machine).....	A/R
13	111319	Screw (6-32 x 1/2 Truss Head) (two per box).....	A/R
14	107966	Nut, Grip (10-32 w/ Nylon Insert) (two per high limit thermostat).....	A/R
15	100100	Screw (8-32 x 1/4 Rhd Head) (two per box).....	A/R
16	107922	Box and Cover Assembly, Thermostat (one per tank).....	A/R
17	104682	Thermometer (2" Stem).....	A/R
18	102505	Plug, Brass (3/4" NPT) (one per tank).....	A/R
19	106482	Washer, Split (1/4") (three per element).....	A/R
20	100003	Nut, Plain (1/4") (three per element).....	A/R
21	108576	Cover, Booster (one per tank).....	A/R
22	107967	Nut, Grip (1/4-20 w/Nylon Insert) (three per booster cover)....	A/R
23	106026	Washer, Flat (1/4") (three per booster cover).....	A/R
24	111235	Element, Booster (5KW, 208V/3PH).....	A/R
24	111236	Element, Booster (5KW, 240V/3PH).....	A/R
24	111235	Element, Booster (5KW, 380V/3PH) (Connected WYE).....	A/R
24	111236	Element, Booster (5KW, 415V/3PH) (Connected WYE).....	A/R
24	111237	Element, Booster (5KW, 480V/3PH).....	A/R
24	111384	Element, Booster (5KW, 575V/3PH).....	A/R
25	111308	Element, Booster (9KW, 208V/3PH).....	A/R
25	111305	Element, Booster (9KW, 240V/3PH).....	A/R
25	111308	Element, Booster (9KW, 380V/3PH) (Connected WYE).....	A/R
25	111305	Element, Booster (9KW, 415V/3PH) (Connected WYE).....	A/R
25	108579	Element, Booster (9KW, 480V/3PH).....	A/R
25	111122	Element, Booster (9KW, 575V/3PH).....	A/R
26	109985	O-Ring, Booster Element (one per element).....	A/R

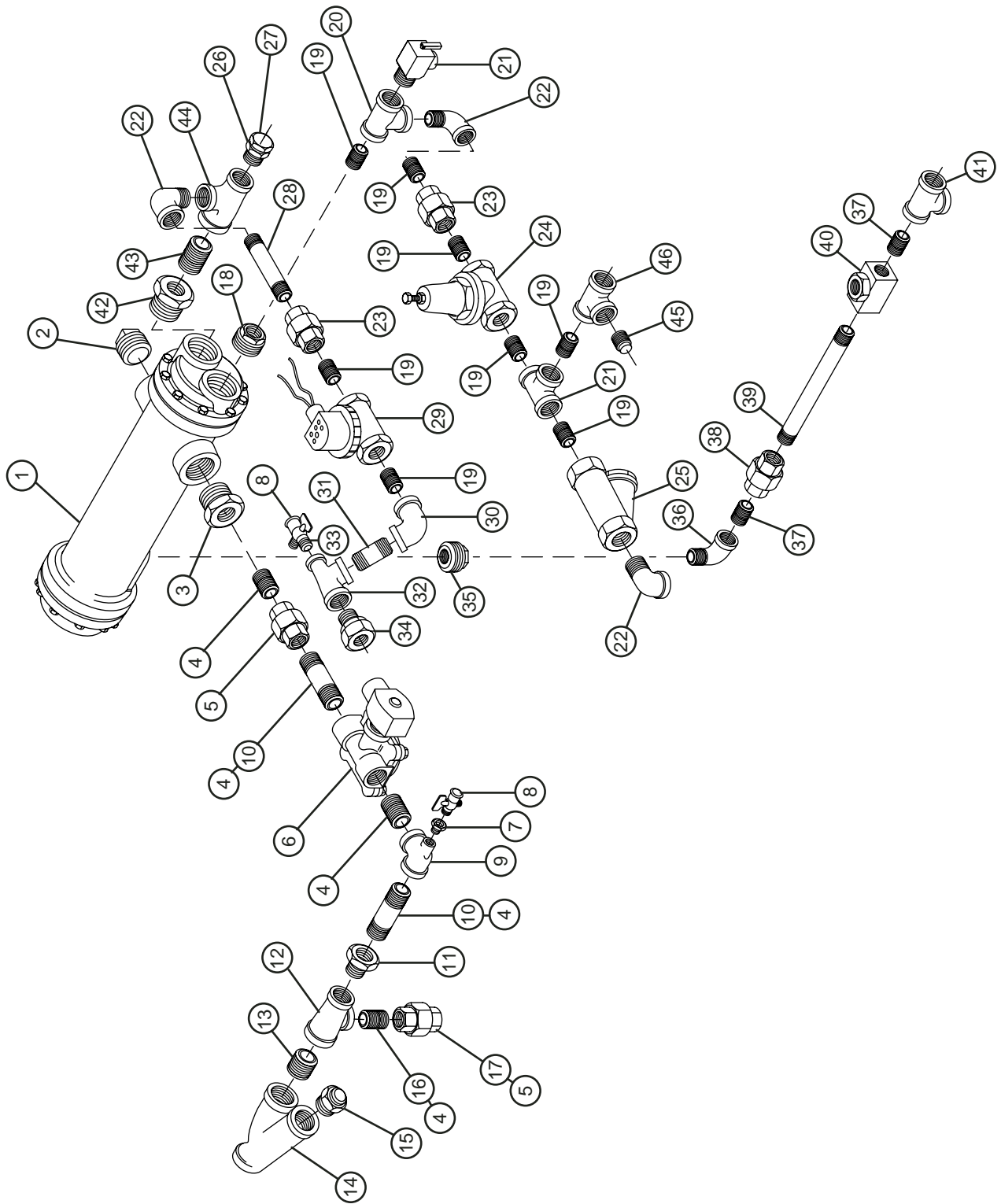

Figure 45 - Steam Booster 70° Rise Standard & Low Pressure
(R-L Direction and Standard Pressure Shown)

STEAM BOOSTER 70° RISE

Fig. 45 Item No.	Part No.	Part Description	Qty.
1	112310	Amtrol Steam Booster #320.....	1
2	112355	Plug 2" NPT BI.....	1
3	100981	Bushing Reducing 2" x 1" BI (Standard Pressure).....	1
3	100983	Bushing Reducing 2" x 1-1/2" BI (Low Pressure).....	1
4	105847	Nipple, Close 1" NPT BI (Standard Pressure).....	2
4	105881	Nipple, Close 1-1/2" NPT BI (Low Pressure).....	5
5	105780	Union 1" NPT BI (Standard Pressure).....	1
5	103586	Union 1-1/2" NPTBI (Low Pressure).....	2
6	110005	Valve Steam Solenoid 1" (Standard Pressure).....	1
6	112344	Valve Steam Solenoid 1-1/2" (Low Pressure).....	1
—	110007	Repair Kit 1".....	1
—	110120	Coil, Solenoid 1".....	1
7	102402	Bushing Red 1/2" x 1/2" NPT BI.....	1
8	100123	Cock Gauge 1/4".....	2
9	105764	Tee Red 1" x 1/2" NPT BI (Standard Pressure).....	1
9	107004	Tee Red 1-1/2" x 1/2" x 1-1/2" NPT BI (Low Pressure).....	1
10	106789	Nipple 1" x 2-1/2" NPT BI (Standard Pressure).....	2
11	100979	Bushing Red 1-1/2" x 1" NPT BI (Standard Pressure).....	1
12	107657	Tee Red 2" x 1-1/2" NPT BI.....	1
13	106607	Nipple Close 2" NPT BI.....	1
14	106051	Strainer Line 2" NPT BI.....	1
15	112353	Plug 1" NPT BI.....	1
16	105881	Nipple Close 1-1/2" NPT BI (Standard Pressure).....	1
17	103586	Union 1-1/2" NPT BI (Standard Pressure).....	1
18	106583	Bushing Red 2" x 3/4" NPT BI.....	1
19	100184	Nipple Close 3/4" NPT BI.....	8
20	102521	Tee 3/4" NPT Brass.....	2
21	104649	Valve Relieve 3/4".....	1
22	102444	Elbow Street 3/4" x 90° Brass.....	3
23	100571	Union 3/4" NPT Brass.....	2
24	107550	Pressure Reducing Valve 3/4".....	1
25	110768	Strainer Line 3/4" Brass.....	1
26	102392	Bushing Red 3/4" x 1/2" Brass.....	1
27	100128	Thermostat (Not Shown).....	1
28	102657	Nipple 3/4" NPT x 3" LG Brass.....	1
29	109887	Valve 3/4".....	1
—	109903	Repair Kit 3/4".....	1
—	108516	Coil, Solenoid.....	1
30	102442	Elbow 3/4" x 90° Brass.....	1
31	102470	Nipple 3/4" NPT x 3" LG Brass.....	1

STEAM BOOSTER 70° RISE (CONT.)

Fig. 45 Item No.	Part No.	Part Description	Qty.
32	102525	Tee Red 3/4" x 1/2" x 3/4" NPT Brass	1
33	102388	Bushing Red 1/2" x 1/4" Brass	1
34	109879	Fitting, Comp 7/8 OD x 3/4" NPT Male Brass	1
35	112341	Bushing Red 2" x 3/4" BI	1
36	105731	Street Elbow 3/4" x 90° BI	1
37	105803	Nipple Close 3/4" BI	2
38	105779	Union 3/4" NPT BI	1
39	105841	Nipple 3/4" x 10" BI	1
40	112339	Steam Trap 3/4" NPT	1
41	112359	Tee Red 3/4" x 3/4" x 1" NPT BI	1
42	106498	Bush Red 2" x 1-1/2" Brass	1
43	101061	Nipple Close 1-1/4" NPT Brass	1
44	100583	Tee 1-1/4" x 3/4" x 3/4" NPT Brass	1
45	102504	Plug 1/2" NPT Brass	1
46	102526	Tee Red 3/4" x 3/4" x 1/2" NPT Brass	1
—	601547	Booster Assembly Complete 70° Rise, 1-1/2" Piping, R-L Direction, Low Pressure	
—	601548	Booster Assembly Complete 70° Rise, 1-1/2" Piping, L-R Direction, Low Pressure	
—	601549	Booster Assembly Complete 70° Rise, 1" Piping, R-L Direction, Standard Pressure	
—	601550	Booster Assembly Complete 70° Rise, 1" Piping, L-R Direction, Standard Pressure	

**THIS PAGE
INTENTIONALLY
LEFT BLANK**

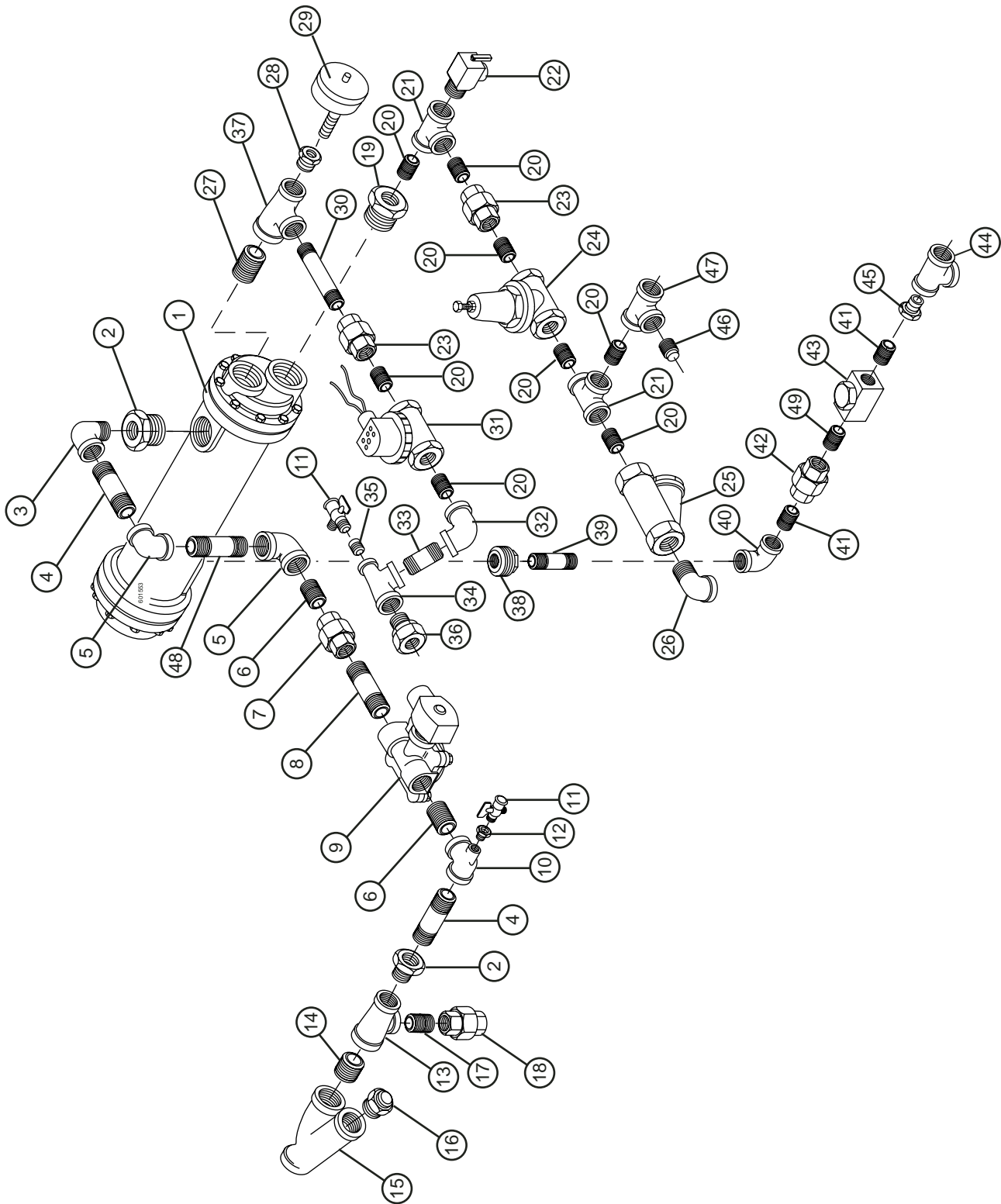

Figure 46 - Steam Booster 40° Rise Standard Pressure, Optional EconoRinse
 40° & 70° Rise Low & Standard Pressure
 (R-L Direction Shown)

STEAM BOOSTER 40° RISE

Fig. 46 Item No.	Part No.	Part Description	Qty.
1	112308	Amtrol Steam Booster #180.....	1
2	100979	Bushing Red 1-1/2" x 1" BI.....	2
3	100134	Elbow Street 1" x 90° BI.....	1
4	106789	Nipple 1" x 3-1/2" NPT BI.....	2
5	105733	Elbow 1" x 90° BI.....	2
6	105847	Nipple Close 1" NPT.....	2
7	105780	Union 1" NPT BI.....	1
8	105851	Nipple 1" x 2-1/2" NPT BI.....	1
9	110005	Valve Steam Solenoid 1".....	1
—	110007	Repair Kit 1".....	1
—	110120	Coil, Solenoid.....	1
10	105764	Tee Red 1" x 1/2" x 1" NPT BI.....	1
11	100123	Cock Gauge 1/2".....	2
12	102402	Bushing Red 1/2" x 1/4" NPT BI.....	1
13	107657	Tee Red 2" x 1-1/2" x 1-1/2" NPT BI.....	1
14	106607	Nipple Close 2" NPT BI.....	1
15	106051	Strainer Line 2" NPT BI.....	1
16	112353	Plug 1" NPT BI.....	1
17	105881	Nipple Close 1-1/2" NPT BI.....	1
18	103586	Union 1-1/2" NPT BI.....	1
19	102399	Bushing Red 1-1/4" x 3/4" Brass.....	2
20	100184	Nipple Close 3/4" NPT Brass.....	8
21	102521	Tee 3/4" NPT Brass.....	2
22	104649	Valve Relief 3/4".....	1
23	100571	Union 3/4" NPT Brass.....	2
24	107550	Pressure Reducing Valve 3/4".....	1
25	110768	Strainer Line 3/4" Brass.....	1
26	102444	Elbow Street 3/4" x 90° Brass.....	1
27	101061	Nipple Close 1-1/2" NPT Brass.....	1
28	102392	Bush Red 3/4" x 1/2" Brass.....	1
29	100128	Thermostat.....	1
30	102657	Nipple 3/4" NPT x 5" LG Brass.....	1
31	109887	Valve 3/4".....	1
—	109903	Repair Kit 3/4".....	1
—	108516	Coil, Solenoid.....	1
32	102442	Elbow 3/4" x 90° Brass.....	1
33	102470	Nipple 3/4" NPT x 3" LB Brass.....	1
34	102525	Tee Red 3/4" x 1/2" x 3/4" NPT Brass.....	1
35	102388	Bushing Red 1/2" x 1/4" Brass.....	1
36	109879	Fitting, Comp 7/8 OD x 3/4" NPT Male Brass.....	1

STEAM BOOSTER 40° RISE (CONT.)

Fig. 46 Item No.	Part No.	Part Description	Qty.
37	100583	Tee Red 1-1/4" x 3/4" x 3/4" NPT Brass	1
38	112349	Bushing Red 1-1/2" x 1/2" BI.....	1
39	105783	Nipple 1/2" x 2" NPT BI.....	1
40	102288	Elbow 1/2" x 90° BI.....	1
41	105782	Nipple Close 1/2" NPT BI	3
42	105778	Union 1/2" NPT BI	1
43	111380	Steam Trap 1/2" NPT	1
44	112359	Tee Red 3/4" x 3/4" x 1" NPT BI	1
45	103465	Bushing Red 3/4" x 1/2" NPT BI.....	1
46	102504	Plug 1/2" NPT Brass	1
47	102526	Tee Red 3/4" x 3/4" x 1/2" NPT Brass	1
48	105856	Nipple 1" x 4" NPT BI.....	1
49	112748	Nipple 1/2" x 3-3/4" NPT BI	1
—	601554	Booster Assembly Complete 40° Rise, 1" Piping, L-R Direction, Low Pressure & Standard w/EconoRinse, Standard Pressure UCCW	
—	601553	Booster Assembly Complete 40° Rise, 1" Piping, R-L Direction, Low Pressure & Standard w/EconoRinse, Standard Pressure UCCW	

**THIS PAGE
INTENTIONALLY
LEFT BLANK**

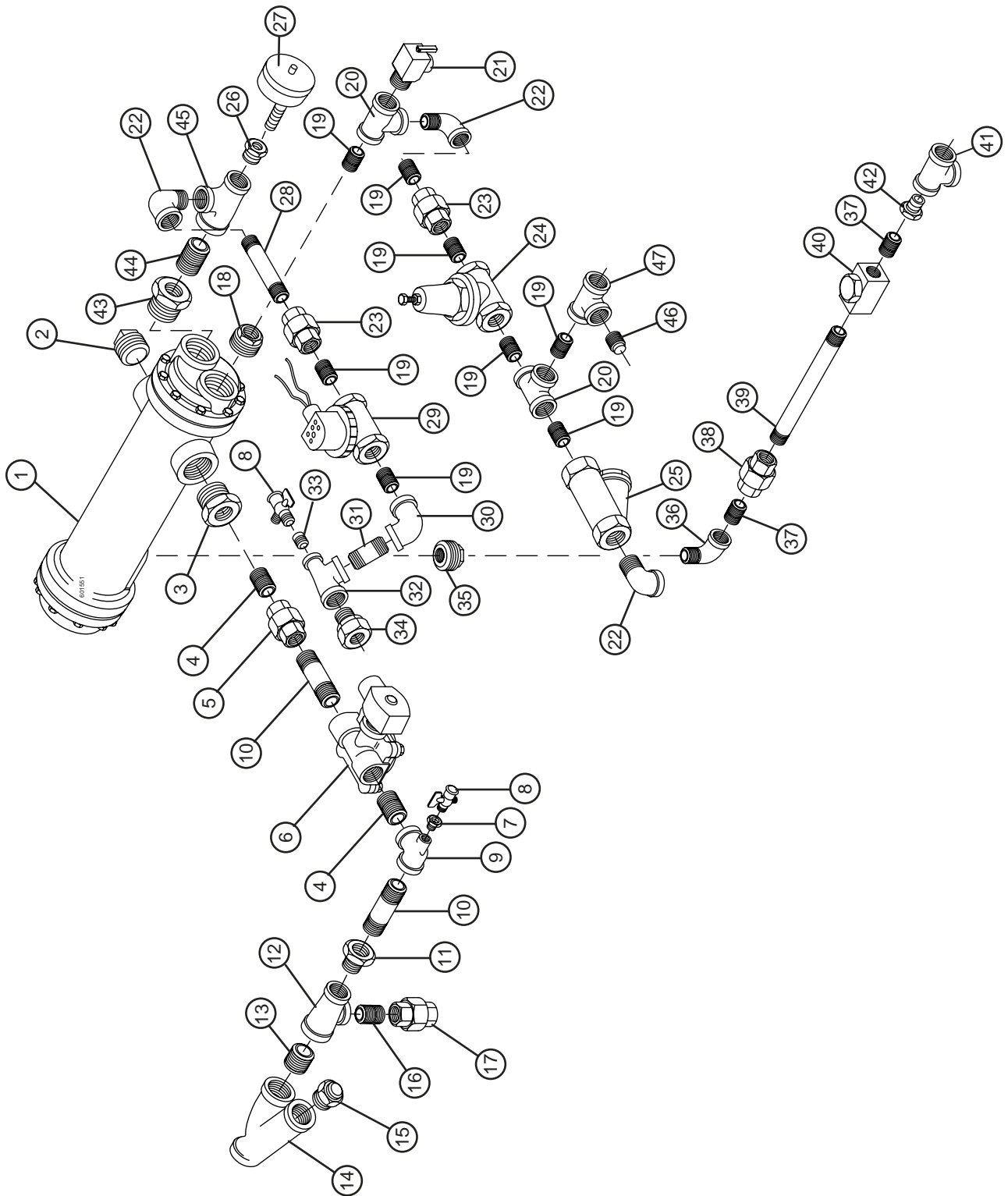

Figure 47 - Steam Booster 40° Rise Low Pressure - 7 PSI
(R-L Direction Shown)

**STEAM BOOSTER 40° RISE
LOW PRESSURE SYSTEMS ONLY - 7 PSI**

Fig. 47 Item No.	Part No.	Part Description	Qty.
1	112309	Amtrol Steam Booster #260.....	1
2	112355	Plug 2" NPT BI	1
3	100981	Bushing Reducing 2" x 1" BI	1
4	105847	Nipple, Close 1" NPT BI	2
5	105780	Union 1" NPT BI	1
6	110005	Valve Steam Solenoid 1"	1
—	110007	Repair Kit 1"	1
—	110120	Coil, Solenoid 1"	1
7	102402	Bushing Red 1/2" x 1/4" NPT BI.....	1
8	100123	Cock Gauge 1/4"	2
9	105764	Tee Red 1" x 1/2" x 1" NPT BI	1
10	106789	Nipple 1" x 3-1/2" NPT BI	2
11	100979	Bushing Red 1-1/2" x 1" NPT BI	1
12	107657	Ree Red 2" x 1-1/2" x 1-1/2" NPT BI	1
13	106607	Nipple Close 2" NPT BI	1
14	106051	Strainer Line 2" NPT BI	1
15	112353	Plug 1" NPT BI	1
16	105881	Nipple Close 1-1/2" NPT BI	1
17	103586	Union 1-1/2" NPT BI	1
18	106583	Bushing Red 2" x 3/4" NPT Brass.....	1
19	100184	Nipple Close 3/4" NPT Brass	8
20	102521	Tee 3/4" NPT Brass.....	2
21	104649	Valve Relief 3/4"	1
22	102444	Elbow Street 3/4" x 90° Brass	3
23	100571	Union 3/4" NPT Brass	2
24	107550	Pressure Reducing Valve 3/4"	1
25	110768	Strainer Line 3/4" Brass	1
26	102392	Bushing Red 3/4" x 1/2" Brass	1
27	100128	Thermostat.....	1
28	102657	Nipple 3/4" NPT x 3" LG Brass	1
29	109887	Steam Solenoid Valve 3/4"	1
—	109903	Repair Kit 3/4"	1
—	108516	Coil, Solenoid.....	1
30	102442	Elbow 3/4" x 90° Brass.....	1
31	102470	Nipple 3/4" NPT x 3" LG Brass	1
32	102525	Tee Red 3/4" x 1/2" x 3/4" NPT Brass	1
33	102388	Bushing Red 1/2" x 1/4" Brass	1
34	109879	Fitting, Comp 7/8 OD x 3/4" NPT Male Brass	1
35	112365	Bushing Red 2" x 1/2" BI	1

**STEAM BOOSTER 40° RISE (CONT.)
LOW PRESSURE SYSTEMS ONLY - 7 PSI**

Fig. 47 Item No.	Part No.	Part Description	Qty.
36	100147	Street Elbow 1/2" x 90° BI	1
37	104782	Nipple Close 1/2" BI.....	2
38	105778	Union 1/2" NPT BI	1
39	111306	Nipple 1/2" x 9-1/2" BI.....	1
40	111380	Steam Trap 1/2" NPT	1
41	112359	Tee Red 3/4" x 3/4" x 1" NPT BI	1
42	103465	Bush Red 3/4" x 1/2" Brass	1
43	106498	Bush Red 2" x 1-1/4" Brass	1
44	101061	Nipple Close 1-1/4" NPT Brass	1
45	100583	Tee 1-1/4" x 3/4" x 3/4" NPT Brass.....	1
46	102504	Plug 1/2" NPT Brass	1
47	102526	Tee Red 3/4" x 3/4" x 1/2" NPT Brass	1
—	601551	Booster Assembly Complete 40° Rise, 1" Piping, R-L Direction, Low Pressure	
—	601552	Booster Assembly Complete 70° Rise, 1" Piping, L-R Direction, Low Pressure	

**THIS PAGE
INTENTIONALLY
LEFT BLANK**

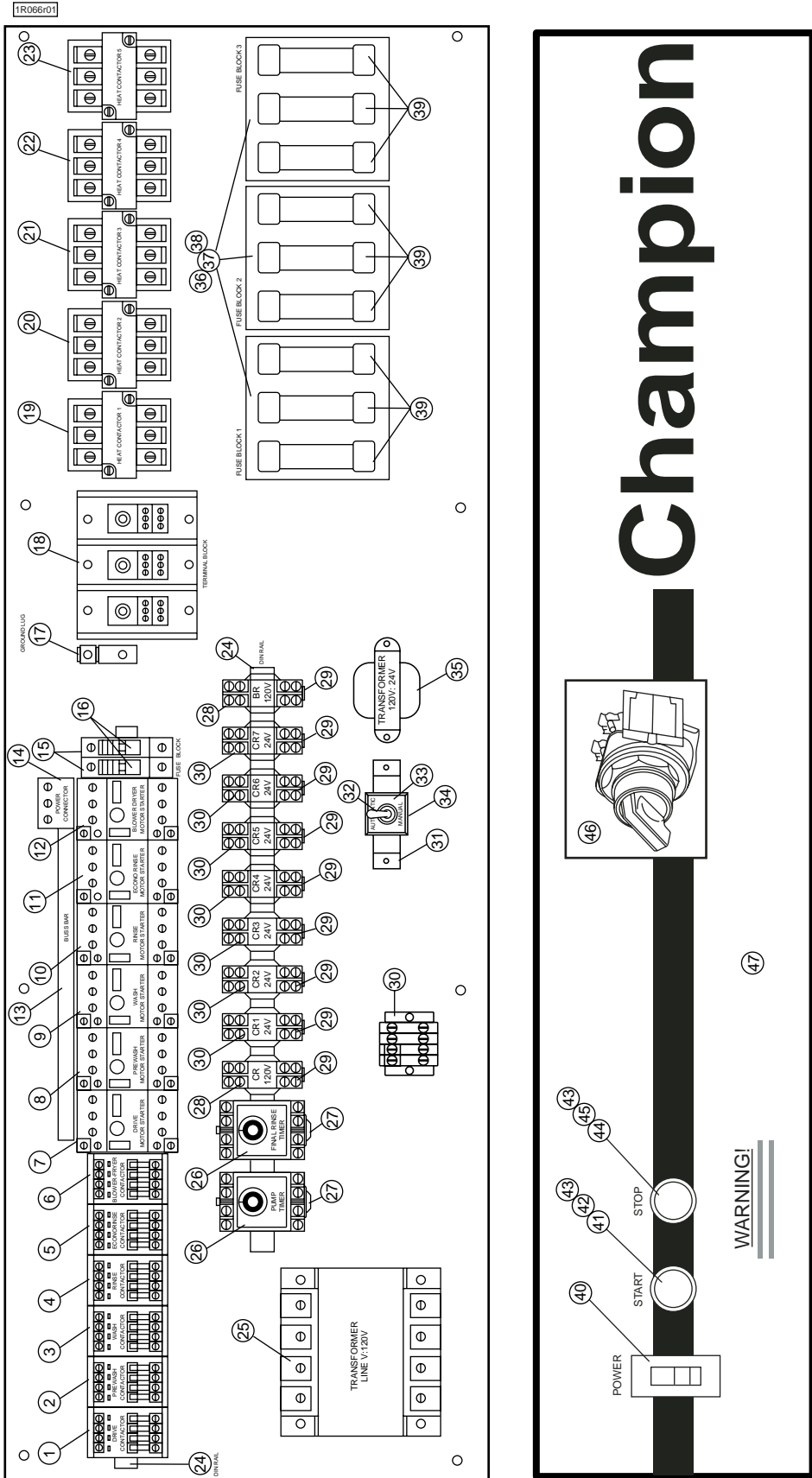

Figure 48 - Control Cabinet

CONTROL CABINET

Fig. 48 Item No.	Part No.	Part Description	Qty.
1	108122	Contact, (Motor) 12A (Drive Motor)	1
2	108122	Contact, (Motor) 12A (Prewash Pump Motor)	1
3	108122	Contact, (Motor) 12A (Wash Pump Motor).....	1
4	108122	Contact, (Motor) 12A (Rinse Pump Motor).....	1
5	108122	Contact, (Motor) 12A (Opt EconoRinse Pump Motor)	1
6	108122	Contact, (Motor) 12A (Opt Steam Blower Dryer Motor).....	1
7	110804	Starter Mtr OL GV2-M07 w/Aux - 1/2HP Drive (208-240V).....	1
7	110803	Starter Mtr OL GV2-M06 w/Aux - 1/2HP Drive (380-415V).....	1
7	110803	Starter Mtr OL GV2-M06 w/Aux - 1/2HP Drive (480V)	1
7	110802	Starter Mtr OL GV2-M05 w/Aux - 1/2HP Drive (575V)	1
8	110805	Starter Mtr OL GV2-M08 w/Aux - 1HP Prewash (208-240V)	1
8	110804	Starter Mtr OL GV2-M07 w/Aux - 1HP Prewash (380-415V)	1
8	110804	Starter Mtr OL GV2-M07 w/Aux - 1HP Prewash (480V).....	1
8	110803	Starter Mtr OL GV2-M06 w/Aux - 1HP Prewash (575V).....	1
8	112691	Overload, Motor Starter - 2HP Prewash (208-240V).....	1
8	110805	Starter Mtr OL GV2-M08 w/Aux - 2HP Prewash (380-415V)	1
8	110805	Starter Mtr OL GV2-M08 w/Aux - 2HP Prewash (480V).....	1
8	112692	Overload, Motor Starter - 2HP Prewash (575V)	1
8	110807	Starter Mtr OL GV2-M14 w/Aux - 3HP Prewash (208-240V)	1
8	110806	Starter Mtr OL GV2-M10 w/Aux - 3HP Prewash (380-415V)	1
8	110806	Starter Mtr OL GV2-M10 w/Aux - 3HP Prewash (480V).....	1
8	110806	Starter Mtr OL GV2-M08 w/Aux - 3HP Prewash (575V).....	1
9	110807	Starter Mtr OL GV2-M14 w/Aux - 3HP Wash (208-240V).....	1
9	110806	Starter Mtr OL GV2-M10 w/Aux - 3HP Wash (380-415V).....	1
9	110806	Starter Mtr OL GV2-M10 w/Aux - 3HP Wash (480V)	1
9	110805	Starter Mtr OL GV2-M08 w/Aux - 3HP Wash (575V)	1
10	110807	Starter Mtr OL GV2-M14 w/Aux - 3HP Power Rinse (208-240V).....	1
10	110806	Starter Mtr OL GV2-M10 w/Aux - 3HP Power Rinse (380-415V).....	1
10	110806	Starter Mtr OL GV2-M10 w/Aux - 3HP Power Rinse (480V).....	1
10	110807	Starter Mtr OL GV2-M14 w/Aux - 3HP Power Rinse (575V).....	1
11	110803	Starter Mtr OL GV2-M06 w/Aux - 1/4HP (Opt EconoRinse)(208-240V)	1
11	110802	Starter Mtr OL GV2-M05 w/Aux - 1/4HP (Opt EconoRinse)(380-415V)	1
11	110802	Starter Mtr OL GV2-M05 w/Aux - 1/4HP (Opt EconoRinse)(480V)	1
11	110806	Starter Mtr OL GV2-M10 w/Aux - 1/4HP (Opt EconoRinse)(575V)	1
12	110807	Starter Mtr OL GV2-M14 w/Aux - 2HP (Opt Steam Blower Dryer)(208-240V)	1
12	110806	Starter Mtr OL GV2-M10 w/Aux - 2HP (Opt Steam Blower Dryer)(380V)	1
12	110805	Starter Mtr OL GV2-M08 w/Aux - 2HP (Opt Steam Blower Dryer)(415V)	1
12	110805	Starter Mtr OL GV2-M08 w/Aux - 2HP (Opt Steam Blower Dryer)(480V)	1
12	110805	Starter Mtr OL GV2-M08 w/Aux - 2HP (Opt Steam Blower Dryer)(575V)	1
13	111633	Bus Bar, 2 Unit	1
13	111671	Bus Bar, 3 Unit	1
13	111634	Bus Bar, 4 Unit	1
13	111635	Bus Bar, 5 Unit	1
14	111636	Power Connector, 3 Pole	1

CONTROL CABINET (CONT.)

Fig. 48 Item No.	Part No.	Part Description	Qty.
15	111153	Fuse Block.....	2
16	111823	Fuse, 6A (208-240V)	2
16	111822	Fuse, 5A (380-415V)	2
16	111821	Fuse, 3A	2
17	103310	Wire Lug, Ground (Use with 115A Terminal Block).....	1
17	103311	Wire Lug, Ground (Use with 200A or 310A Terminal Block) ..	1
18	111833	Block, Terminal (185Amp)	1
18	109014	Block, Terminal (310Amp)	1
19	111827	Contactor, (Heat-Electric) 50Amp 3 Pole.....	A/R
19	111827	Contactor, (Heat-Electric) 60Amp 3 Pole.....	A/R
20	111827	Contactor, (Heat-Electric) 50Amp 3 Pole.....	A/R
20	111827	Contactor, (Heat-Electric) 60Amp 3 Pole.....	A/R
21	111827	Contactor, (Heat-Electric) 50Amp 3 Pole.....	A/R
21	111827	Contactor, (Heat-Electric) 60Amp 3 Pole.....	A/R
22	111827	Contactor, (Heat-Electric) 50Amp 3 Pole.....	A/R
22	111827	Contactor, (Heat-Electric) 60Amp 3 Pole.....	A/R
23	111827	Contactor, (Heat-Electric) 50Amp 3 Pole.....	A/R
23	111827	Contactor, (Heat-Electric) 60Amp 3 Pole.....	A/R
24	110849	Din Rail (Specify Length).....	A/R
25	107091	Transformer, Control 500VA (208-240V, 480V)	1
25	109148	Transformer, Control 500VA (380-415V).....	1
25	111046	Transformer, Control 500VA (550-575-600V)	1
26	112351	Timer (0-6 Minute)	1
27	112352	Socket, Timer	1
28	111068	Relay, 120 Vac.....	1
29	111036	Socket, Relay (One per relay).....	A/R
30	111067	Relay, 24 Vac.....	A/R
31	304326	Bracket, Switch	1
32	107198	Switch, Toggle (Bypass)	1
33	108370	Washer, Lock.....	1
34	104858	Nameplate (Automatic/Overload)	1
35	111277	Transformer, Control (120V to 24V)	1
36	180171	Fuse Block 600V (35Amp to 60Amp).....	A/R
37	106925	Fuse Block 600V (25Amp to 30Amp).....	A/R
38	108424	Fuse Block 600V (70Amp to 100Amp).....	A/R
39	108517	Fuse 25Amp (ATMR)	A/R
39	100929	Fuse 30Amp (ATMR)	A/R
39	180172	Fuse 35Amp (Class J)	A/R
39	180173	Fuse 40Amp (Class J)	A/R
39	180174	Fuse 45Amp (Class J)	A/R
39	180175	Fuse 50Amp (Class J)	A/R
39	180176	Fuse 60Amp (Class J)	A/R
39	180060	Fuse 70Amp (Class T)	A/R
39	180059	Fuse 80Amp (Class T)	A/R
39	180448	Fuse 90Amp (Class T)	A/R

CONTROL CABINET (CONT.)

Fig. 48 Item No.	Part No.	Part Description	Qty.
39	180042	Fuse 100Amp	A/R
40	111980	Power Switch/Circuit Breaker 5Amp.....	1
41	111614	Pushbutton Start (Green).....	1
42	111617	Contact Block (NO)	1
43	113140	Boot, Silicone, Pushbutton (Beginning w/Serial J1364).....	A/R
44	111615	Pushbutton Stop (Red)	1
45	111616	Contact Block (NC)	1
46	107351	Optional Toggle Switch.....	1
47	111597	Decal.....	1
—	900725	Kit*Pushbutton Green NO (includes items 41, 42, 43)	
—	900726	Kit*Pushbutton Red NC (includes items 43, 44, 45)	

****SPECIAL NOTE:**

Heat Contactors, Fuse Blocks, and Fuses depend on the Electric Heat Options installed.
Refer to Figure 55 — UC Electric Tank Heat.

The Data Tables list: Recommended Contactor Amp Rating
Required Fuse Rating
Total Tank Heater Kilowatts

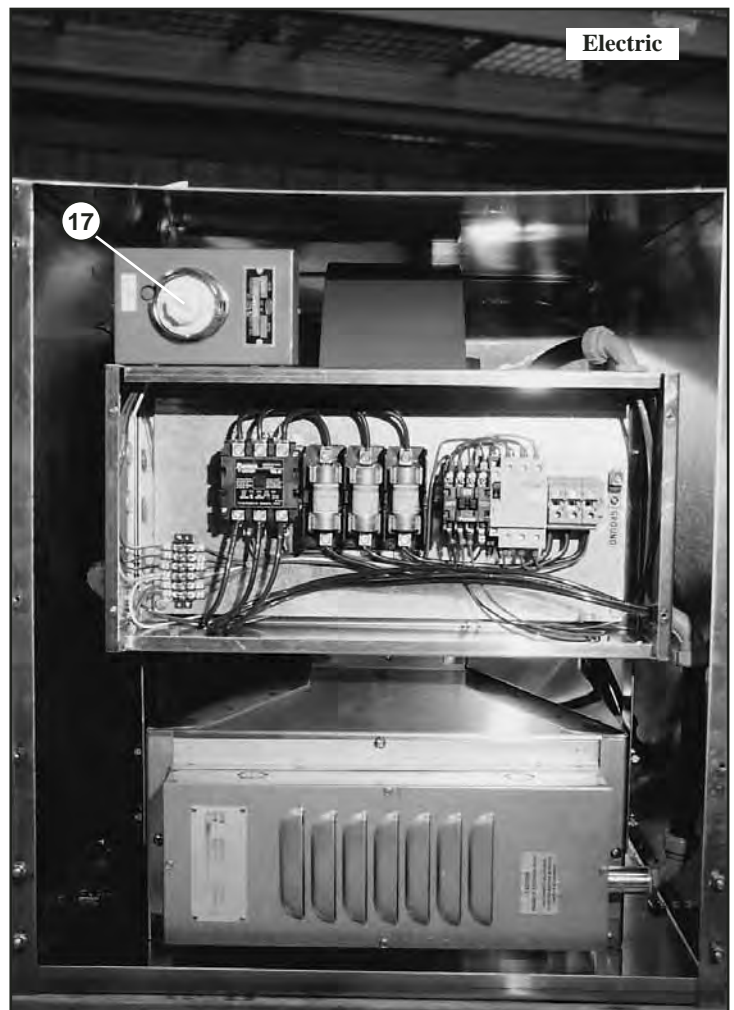
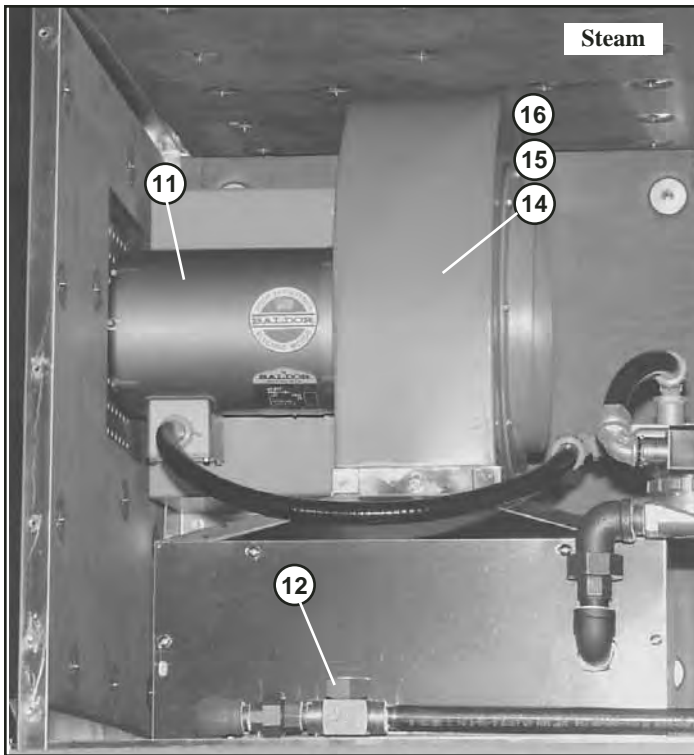
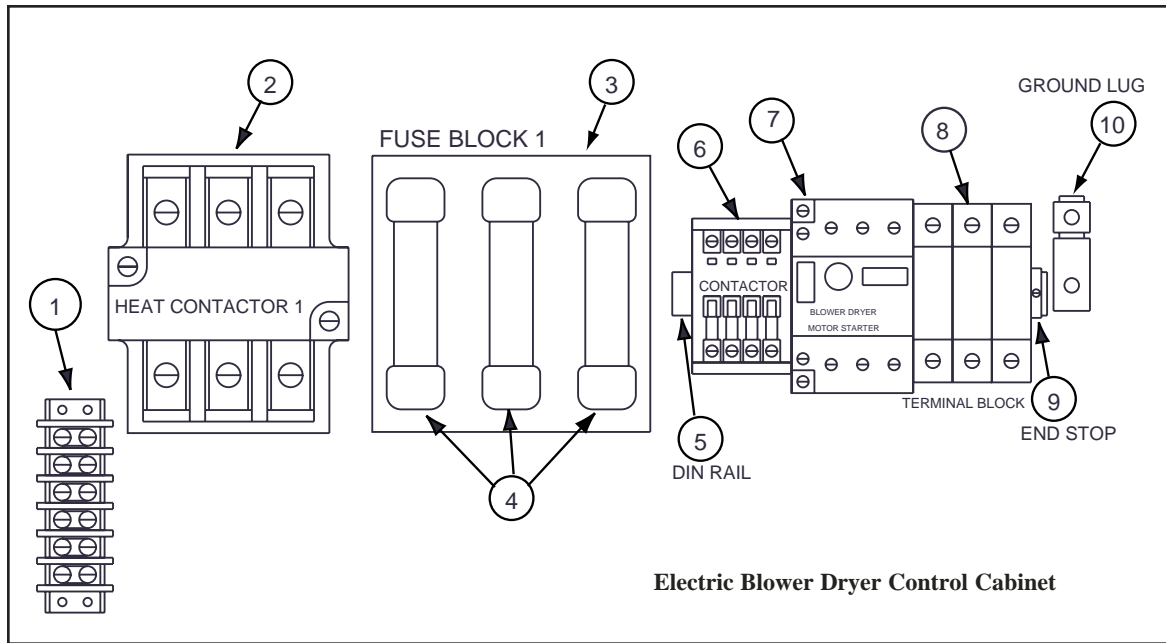

Note:

Steam Blower Dryer Electrical Control Components are located in Main Control Cabinet.

(See Figure 48, Page 89 for Parts)

Figure 49 - Blower Dryer (Optional)

OPTIONAL BLOWER DRYER (BDS)

Fig. 49 Item No.	Part No.	Part Description	Qty.
1	108272	Terminal Block.....	1
2	111231	Contactor, (Heat-Electric) 75A 3 Pole (208-240V/3PH).....	1
2	103210	Contactor, (Heat-Electric) 60A 3 Pole (380-415V/3PH).....	1
2	105514	Contactor, (Heat-Electric) 50A 3 Pole (480V/3PH).....	1
2	105514	Contactor, (Heat-Electric) 50A 3 Pole (575V/3PH).....	1
3	108424	Block, Fuse 600V (100Amp) (208-240V/3PH).....	1
3	180171	Block, Fuse 600V (60Amp) (380-415, 480, 575V/3PH).....	1
4	108448	Fuse 90A (JJN Class T) (208V/3PH)	3
4	180059	Fuse 80A (JJN Class T) (240V/3PH)	3
4	180176	Fuse 60A (A4J) (380-415V/3PH).....	3
4	180174	Fuse 45A (A4J) (480V/3PH)	3
4	180172	Fuse 35A (A4J) (575V/3PH)	3
5	204558	Din Rail	1
6	108122	Contactor, (Motor) 12A w/ Aux Switch (All Voltages).....	1
7	110807	Starter, Mtr OL GV2-M14 w/Aux - 2HP (208-240V/60/3PH).....	1
7	110806	Starter, Mtr OL GV2-M10 w/Aux - 2HP (380-415V/60/3PH).....	1
7	110805	Starter, Mtr OL GV2-M08 w/Aux - 2HP (480V/60/3PH)	1
7	110805	Starter, Mtr OL GV2-M08 w/Aux - 2HP (575V/60/3PH)	1
8	110912	Block, Terminal 115A.....	3
9	110900	End Stop.....	2
10	103310	Wire Lug, Ground	1
—	108338	Element, Heater (25KW, 208V/60/3PH)	1
—	108339	Element, Heater (25KW, 240V/60/3PH)	1
—	108340	Element, Heater (25KW, 480V/60/3PH)	1
—	111138	Element, Heater (25KW, 575V/60/3PH)	1
11	101201	Motor, Blower 2HP (208-240/480V/60/3PH) (Steam or Electric) (Prior to S/N 87550).....	1
11	111830	Motor, Blower 2HP (208-240/480V/60/3PH) (Steam or Electric) (Beginning with S/N 87550).....	1
11	180234	Motor, Blower 2HP (575V/60/3PH) (Steam or Electric) (Prior to S/N 87550).....	1
11	112111	Motor, Blower 2HP (575V/60/3PH) (Steam or Electric) (Beginning with S/N 87550).....	1
12	111380	Trap, Steam	1
13	109887	Valve, Solenoid (3/4").....	1
—	109903	Repair Kit, Solenoid Valve (3/4").....	1
—	108516	Coil, Solenoid Valve (3/4").....	1
14	110150	Housing Assy, Blower (Steam or Electric) (Prior to S/N 87550).....	1
		Includes:	
		1 P/N 112032 Inlet Cone	1 P/N 112035 Pedestal, Drive
		1 112033 Housing Assy	1 112110 Inlet Cone, Shoulder
		1 112034 Upper Drive, Side	1 111992 Impeller
14	410865	Housing Assy, Blower (Steam or Electric) (Beginning with S/N 87550)	1
		Includes:	
		1 P/N 112032 Inlet Cone	1 P/N 112035 Pedestal
		1 112033 Housing Assy	1 111831 Impeller
		1 112034 Upper Drive, Side	
15	204788	Wheel, Blower (Clockwise) (R-L install) (Steam or Electric)	A/R
16	204787	Wheel, Blower (CCW) (L-R install) (Steam or Electric)	A/R
—	109987	Coil, Steam (Not Shown).....	1
17	108335	Thermostat.....	1

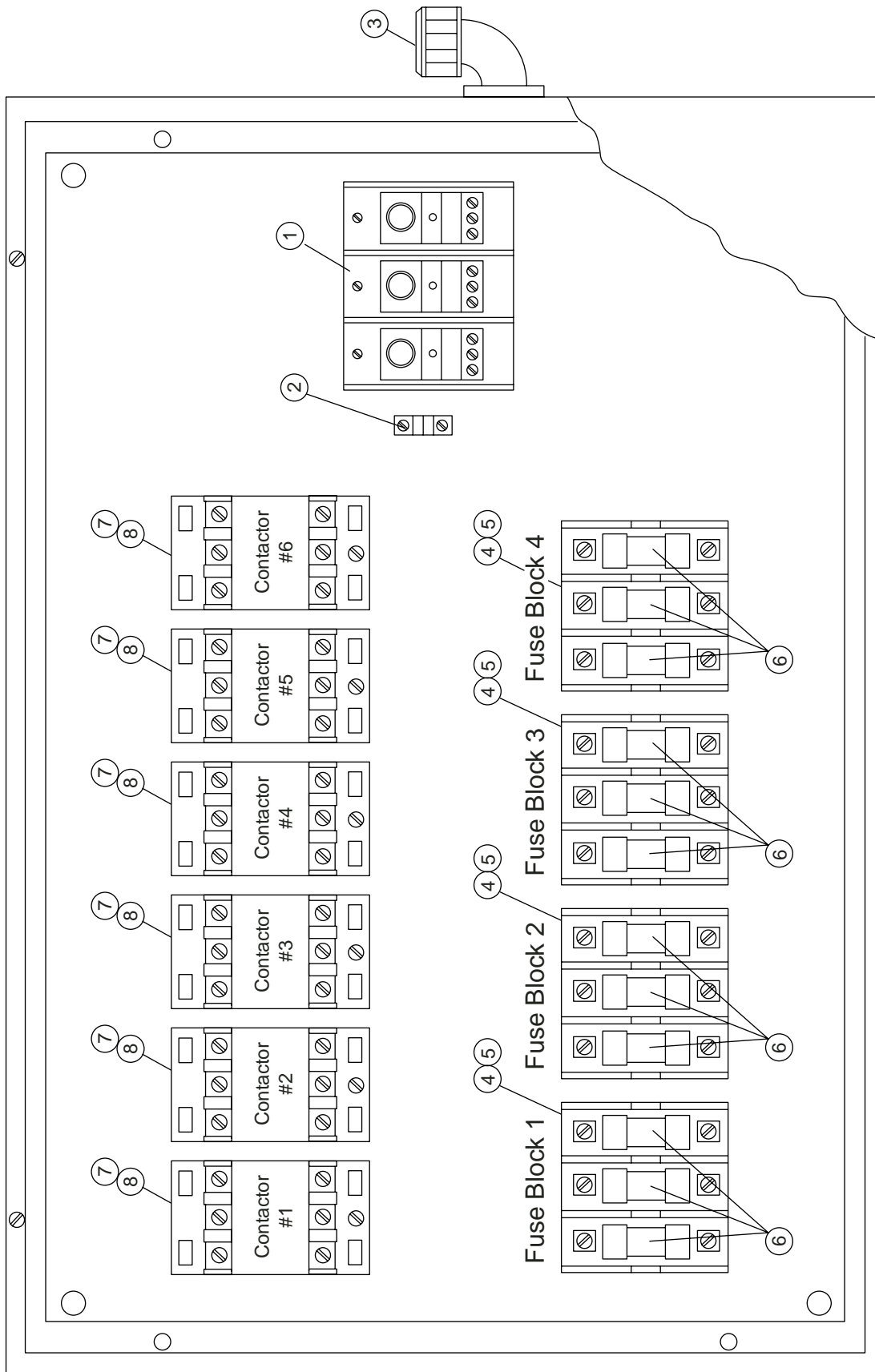

Figure 50 - Control Panel, Electric Booster

CONTROL PANEL, ELECTRIC BOOSTER

Fig. 50 Item No.	Part No.	Part Description	Qty.
1	109014	Block, Terminal 310A (208-240V/3PH).....	1
1	111833	Block, Terminal 185A (380, 415, 480, 575V/3PH).....	1
2	103311	Wire Lug, Ground (208-240V/3PH).....	1
2	103310	Wire Lug, Ground (380, 415, 480, 575V/3PH).....	1
3	110920	Connector, Sealtite	1
4	108424	Block, Fuse 600V (100Amp) (208-240, 380, 415, 480 575V/3PH)....	A/R
5	180171	Block, Fuse 600V (60Amp) (208-240, 380, 415, 480 575V/3PH).....	A/R
6	180243	Fuse 25A (Class J)	A/R
6	180172	Fuse 35A (Class J)	A/R
6	180173	Fuse 40A (Class J)	A/R
6	180174	Fuse 45A (Class J)	A/R
6	180175	Fuse 50A (Class J)	A/R
6	180176	Fuse 60A (Class J)	A/R
6	180060	Fuse 70A (Class T)	A/R
6	180059	Fuse 80A (Class T)	A/R
6	108448	Fuse 90A (Class T)	A/R
6	180042	Fuse 100A (Class T)	A/R
7	111827	Contactor, (Heat-Electric) 60A 3 Pole.....	A/R
8	111827	Contactor, (Heat-Electric) 50A 3 Pole.....	A/R
9	111231	Contactor, (Heat-Electric) 75A 3 Pole.....	A/R

Refer to the Charts below for the Booster Cabinet Components for the 57KW, 63KW, 72KW and 81KW Electric Boosters.

57KW Booster 208V

Component	Rating	P/N
Contactors #1, 3	60A	111827
Contactors #2	50A	111827
Fuse Block #1,2,3,4	60A	180171
Fuses for (Block #1)	60A	180176
Fuses for (Block #2)	45A	180174
Fuses for (Block #4)	35A	180172

57KW Booster 240V

Component	Rating	P/N
Contactors #1, 3	60A	111827
Contactors #2	50A	111827
Fuse Block #1,2,3,4	60A	180171
Fuses for (Block #1,3)	60A	180176
Fuses for (Block #2)	45A	180174
Fuses for (Block #4)	35A	180172

57KW Booster 380V

Component	Rating	P/N
Contactors #1	60A	111827
Contactors #3	50A	111827
Fuse Block #1, 3	60A	180171
Fuses for (Block #1)	45A	180174
Fuses for (Block #3)	45A	180176

57KW Booster 380V

Component	Rating	P/N
Contactors #1	60A	111827
Contactors #3	60A	111827
Fuse Block #1, 3	60A	180171
Fuses for (Block #1)	60A	180176
Fuses for (Block #3)	60A	180176

CONTROL PANEL, ELECTRIC BOOSTER (CONT.)

57KW Booster 480V

Component	Rating	P/N
Contactors #1	60A	111827
Contactors #3	50A	111827
Fuse Block #1, 3	60A	180171
Fuses for (Block #1)	45A	180174
Fuses for (Block #3)	45A	180174

57KW Booster 575V

Component	Rating	P/N
Contactors #1	50A	111827
Contactors #3	50A	111827
Fuse Block #1, 2	60A	180171
Fuses for (Block #1)	40A	180173
Fuses for (Block #)	35A	180172

63KW Booster 208V

Component	Rating	P/N
Contactors #1, 2, 3	60A	111827
Contactors #4	50A	111827
Fuse Block #1, 2	100A	108424
Fuses for (Block #1,2)	70A	180060
Fuses for (Block #3)	100A	180042

63KW Booster 240V

Component	Rating	P/N
Contactors #1, 2, 3	60A	111827
Contactors #4	50A	111827
Fuse Block #1, 2	100A	108424
Fuses for (Block #1,2)	70A	180060
Fuses for (Block #3)	90A	108448

63KW Booster 380V

Component	Rating	P/N
Contactors #1, 2	50A	111827
Contactors #3	60A	111827
Fuse Block #1, 2	60A	180171
Fuses for (Block #1,2)	45A	180174
Fuses for (Block #3)	60A	180176

63KW Booster 415V

Component	Rating	P/N
Contactors #1, 2	50A	111827
Contactors #3	60A	111827
Fuse Block #1, 2, 3	60A	180171
Fuses for (Block #1)	35A	180172
Fuses for (Block #3)	60A	180176

63KW Booster 480V

Component	Rating	P/N
Contactors #1	60A	111827
Contactors #3	50A	111827
Fuse Block #1, 3	60A	180171
Fuses for (Block #1)	60A	180176
Fuses for (Block #3)	50A	180175

63KW Booster 575V

Component	Rating	P/N
Contactors #1	50A	111827
Contactors #3	50A	111827
Fuse Block #1, 3	60A	180171
Fuses for (Block #1)	45A	180174
Fuses for (Block #3)	35A	180172

72KW Booster 208V

Component	Rating	P/N
Contactors #1, 3	75A	111231
Contactors #2, 4	60A	111827
Fuse Block #1, 3	100A	108424
Fuses for (Block #1,3)	90A	108448
Fuses for (Block #2,4)	45A	180174
Fuses for (Block #2,4)	60A	180171

72KW Booster 240V

Component	Rating	P/N
Contactors #1, 3	75A	111231
Contactors #2, 4	50A	111827
Fuse Block #1, 3	100A	108424
Fuses for (Block #1)	80A	180059
Fuses for (Block #2,4)	40A	180173
Fuses for (Block #2,4)	60A	180171

CONTROL PANEL, ELECTRIC BOOSTER (CONT.)

72KW Booster 380V

Component	Rating	P/N
Contactors #1, 2	50A	111827
Contactors #3, 4	50A	111827
Fuse Block #1,2,3,4	60A	180171
Fuses for (Block #1,2)	45A	180176
Fuses for (Block #2,4)	25A	180243

72KW Booster 415V

Component	Rating	P/N
Contactors #1, 2	50A	111827
Contactors #3, 4	50A	111827
Fuse Block #1,2,3,4	60A	180171
Fuses for (Block #1,3)	45A	180176
Fuses for (Block #2,4)	25A	180243

72KW Booster 380V

Component	Rating	P/N
Contactors #1	60A	111827
Contactors #3	60A	111827
Fuse Block #1, 3	60A	180171
Fuses for (Block #1)	60A	180176
Fuses for (Block #3)	60A	180176

72KW Booster 575V

Component	Rating	P/N
Contactors #1	50A	111827
Contactors #3	50A	111827
Fuse Block #1, 3	60A	180171
Fuses for (Block #1)	50A	180175
Fuses for (Block #3)	50A	180175

81KW Booster 280V

Component	Rating	P/N
Contactors #1, 3, 5	60A	111827
Contactors #2, 4, 6	50A	111827
Fuse Block #1, 2, 3	100A	108424
Fuses for (Block #1,2)	100A	180042
Fuses for (Block #3)	100A	180042

81KW Booster 240V

Component	Rating	P/N
Contactors #1, 3, 5	60A	111827
Contactors #2, 4, 6	50A	111827
Fuse Block #1, 2, 3	100A	108424
Fuses for (Block #1,2)	90A	108448
Fuses for (Block #3)	90A	108448

81KW Booster 380V

Component	Rating	P/N
Contactors #1, 3	60A	111827
Contactors #5	60A	111827
Fuse Block #1,2, 3	60A	180171
Fuses for (Block #1,2)	60A	180176
Fuses for (Block #3)	60A	180176

81KW Booster 415V

Component	Rating	P/N
Contactors #1, 3	60A	111827
Contactors #5	60A	111827
Fuse Block #1, 2, 3	60A	180171
Fuses for (Block #1,2)	60A	180176
Fuses for (Block #3)	60A	180176

81KW Booster 480V

Component	Rating	P/N
Contactors #1, 3	50A	111827
Contactors #5	50A	111827
Fuse Block #1, 2, 3	60A	180171
Fuses for (Block #1,2)	50A	180175
Fuses for (Block #3)	50A	180175

81KW Booster 575V

Component	Rating	P/N
Contactors #1, 3	50A	111827
Contactors #5	50A	111827
Fuse Block #1, 2, 3	60A	180171
Fuses for (Block #1,2)	35A	180172
Fuses for (Block #3)	35A	180172

APPENDIXES

APPENDIX A

EconoRinse Section (E2)

- This Option is for the UC-CW only. The EconoRinse section is installed between the power rinse section and the unload section. It is designed to capture and recirculate the final rinse water one additional time before it is used in the rest of the machine. The section measures 2 feet in length and is equipped with a 1/4-HP pump motor. Machines equipped with the EconoRinse section carry the model number UC-CW-WS. The WS stands for Water Saver.

Curtain Location

- The E2 section contains one curtain located in the center of the section. The curtain measures 32" X 10" and hangs from hooks located in the top of the hood.

EconoRinse Spray Pipes

- Two quick-release stainless steel spray pipes, (upper and lower) are located at the entrance end of the E2 section. The spray pipes have removable caps for fast cleaning.

Tank Heat

- The E2 tank heat options are available in either electric or steam. Electric tank heat uses a single 15KW heater element. Steam tank heat uses a steam coil or injector.
THE PROPER TANK HEAT TEMPERATURE SETTING IS 170°F.

Operation

- The EconoRinse 1/4 HP Recirculating Pump runs ONLY when the final rinse operates.
1. Flip the main power switch on the front of the control cabinet to "ON."
The Red light will illuminate.
 2. Press the Green start button.
The conveyor belt will begin to move.
 3. Place an object on the conveyor belt.
When an object on the belt enters the tunnel at the load end of the machine it breaks the electric eye beam.
 - The prewash, wash, and power rinse pumps run.
 - The E2 pump DOES NOT run at this time.
 4. The Final Rinse Timer controls the operation of the E2 1/4HP pump.
 - As an object on the conveyor nears the EconoRinse section the Final Rinse Timer times out.
 - The EconoRinse pump will run. The final rinse will operate as well.
 5. The EconoRinse pump will stop at the same time as the final rinse. In addition,
 - If the conveyor shut-off shelf is moved to the OFF position, the E2 pump will stop. When the shut-off shelf is returned to the ON position, the E2 pump will run until the final rinse stops.
 6. If the Electric Eye Bypass Switch located inside the main control cabinet is placed in the Manual position, the E2 pump will run constantly along with the other pumps whenever the Green start button is operated.

APPENDIX B

Door Safety Switch and Magnet Mounting

Beginning with serial number 87589 and above, the upright conveyor door safety switch magnets will be installed on the inside edge of the door.

The door safety magnetic reed switch will be mounted on the outside of the machine behind a redesigned cover close to the door safety switch magnet.

Refer to Fig. 1 and the parts list below for the component parts.

Item No.	Part No.	Description	Qty.
1	319991-2	Cover, door safety magnetic reed switch	1
2	111478	Bolt (10-32 X 1/2 Hex hd)	1
3	108954	Nut, grip (6-32 w/nylon insert)	6
4	111090	Switch, magnetic reed	1
5	319993	Plate, cover mounting	1
6	111026	Magnet, door safety switch	1
7	100007	Screw (10-32 X 3/8 Truss hd)	2
8	106486	Washer, lock (10-32 split)	2

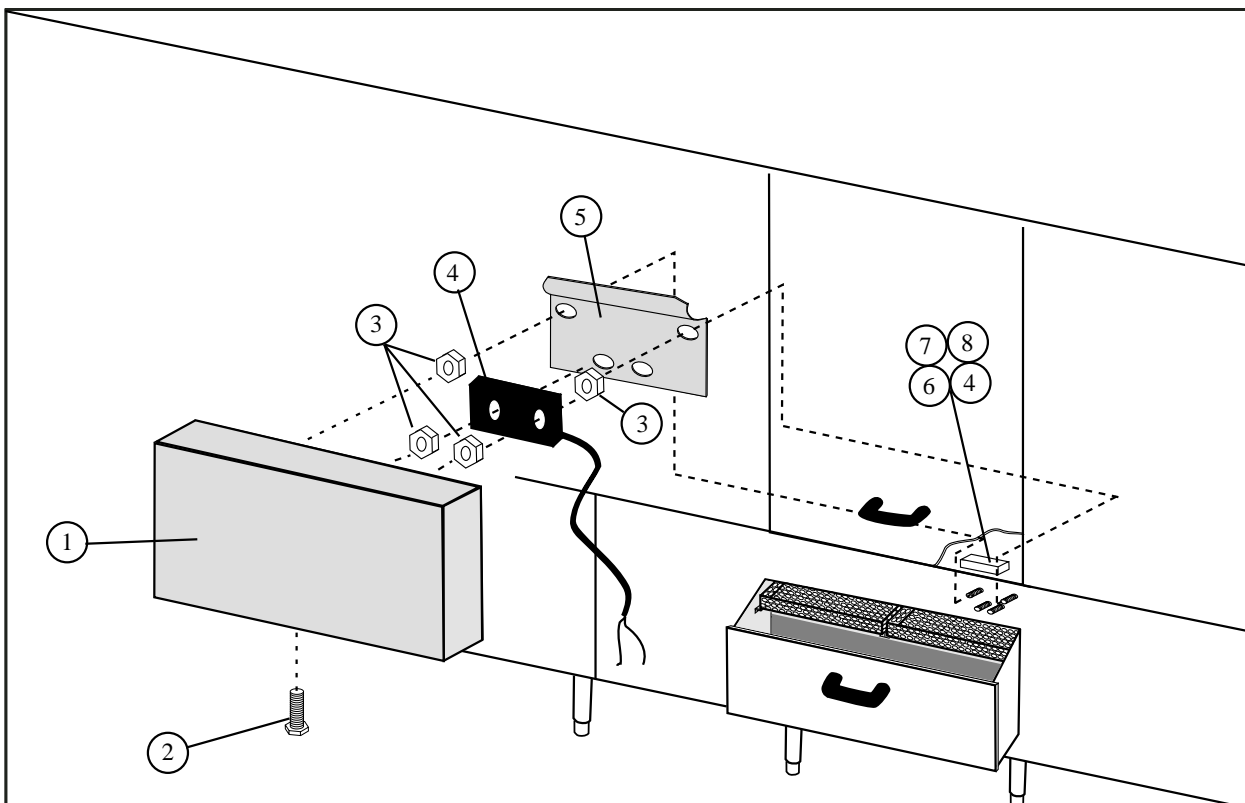

Figure 1- Door Safety Switch and Magnet

APPENDIX C

Cross-flow Elbow Adjustments

The cross flow elbows are placed in the tanks to control the flow of water from one tank to another. Common symptoms of improper cross flow elbow adjustments are:

- Heat loss in one or more tanks
- Low water in a tank
- Excessive soap consumption in wash tank(s).

DO NOT position an elbow as shown in diagrams A and B to the right because:

A- an elbow pointing straight-up will direct too much cross flow water to the drain and,

B- an elbow turned completely on its side will direct too much cross flow water to the next tank.

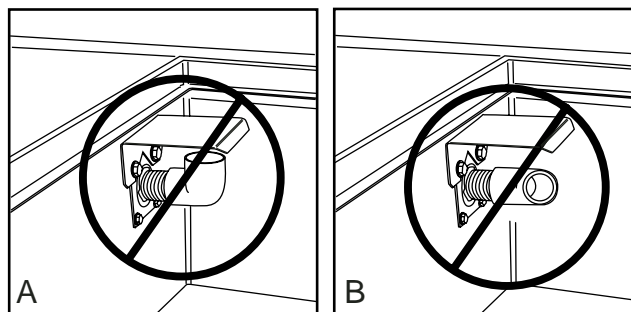

DO NOT POSITION ELBOW THIS WAY

Making the Cross flow Adjustment

- Refer to diagrams C and D at right. Diagram C shows a single cross flow elbow and a cross flow pipe in the tank. Diagram D shows two cross flow elbows and no crossflow pipe.
- Crossflow Charts 1, 2, 3, and 4 on the next pages show the elbow locations. Drain all tanks and match your machine with one of the charts.
- Next, identify the correct tank, then identify the elbow to adjust. The symbol for the elbow looks like this . Note the arrow showing a dimension for each elbow on the chart.
- The dimension on the chart is the same dimension referred to as (x) in diagram C and D at right.
- Go to the machine and measure from the bottom of the tank to the INSIDE lip of the elbow. Turn the elbow until (x) matches the dimension given in the chart for the appropriate tank.
- Adjustment is complete.

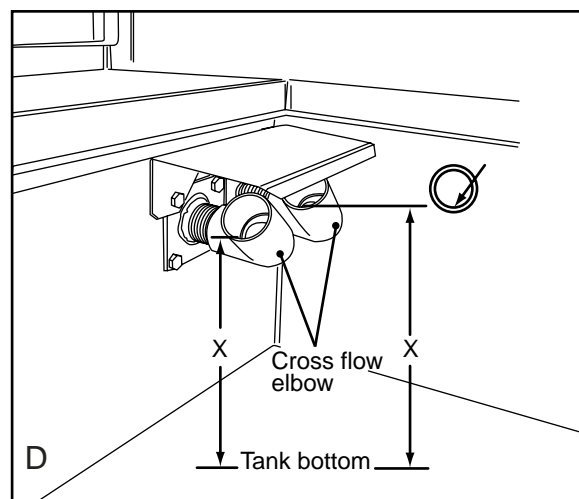
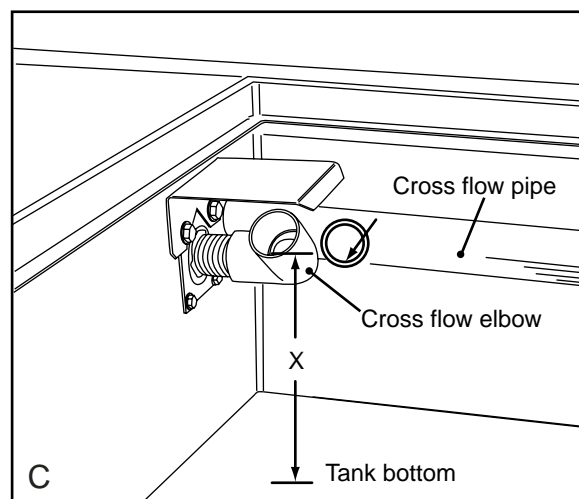

APPENDIX C (cont.)

Chart 1:

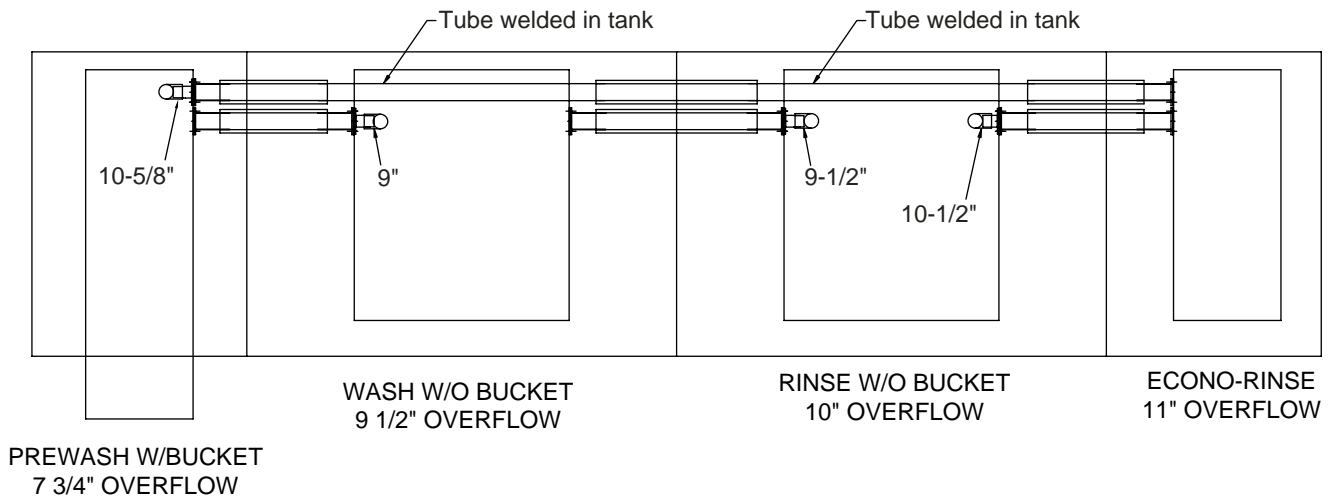
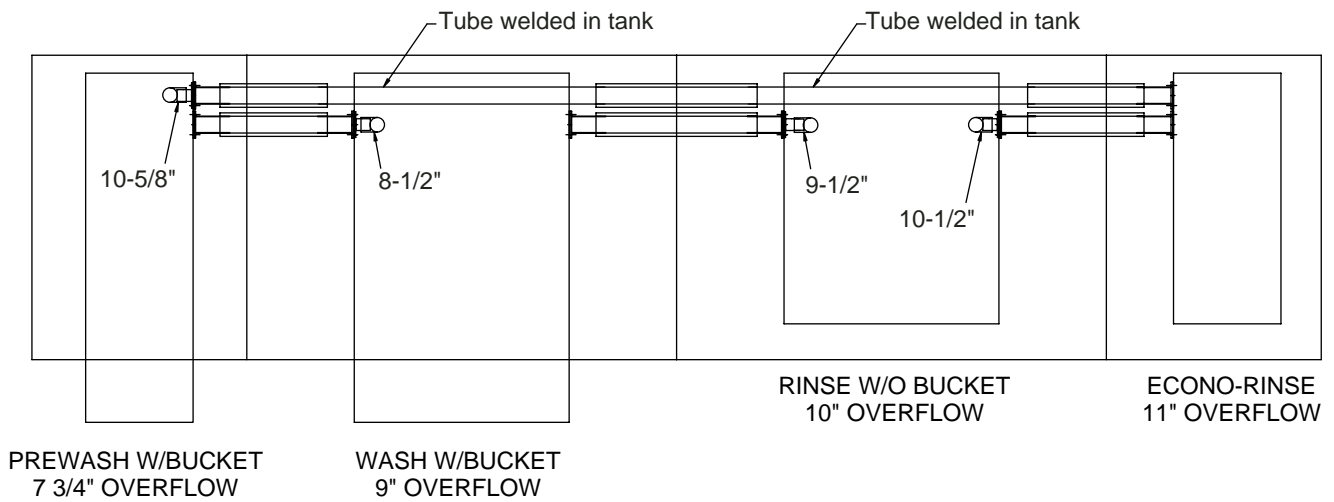
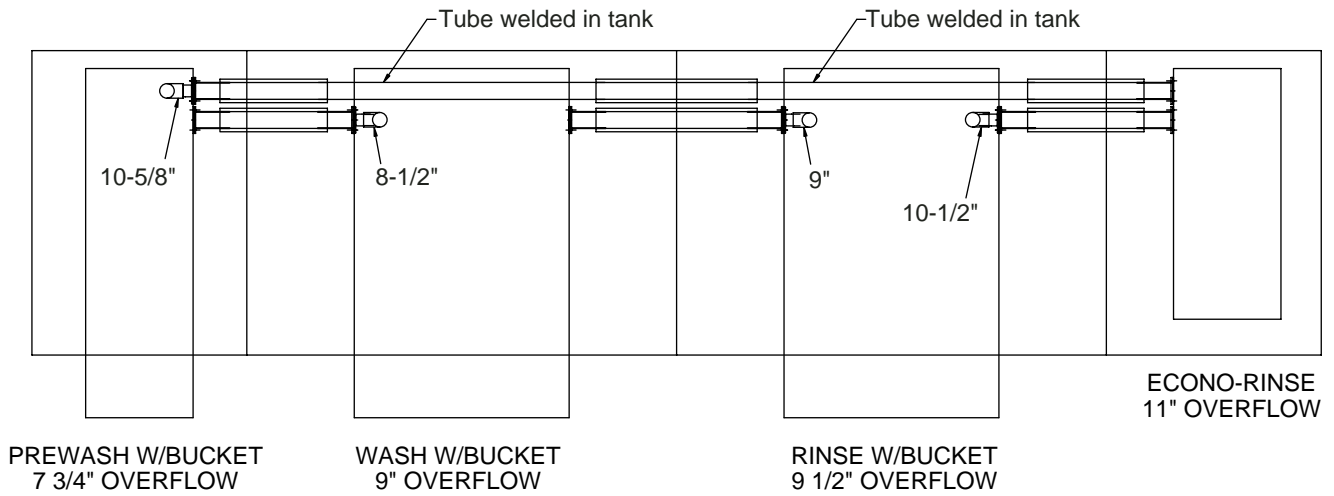

APPENDIX C (cont.)

Chart 2:

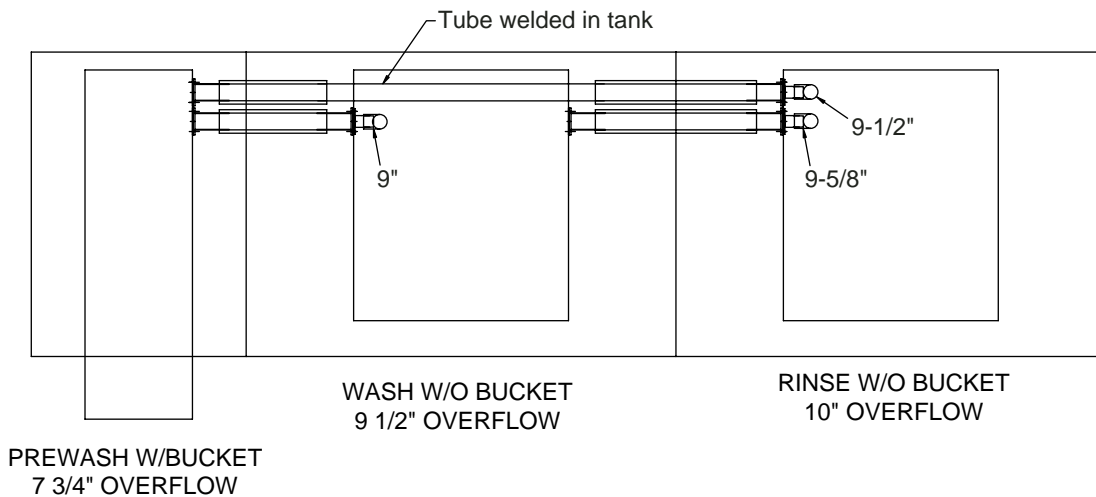
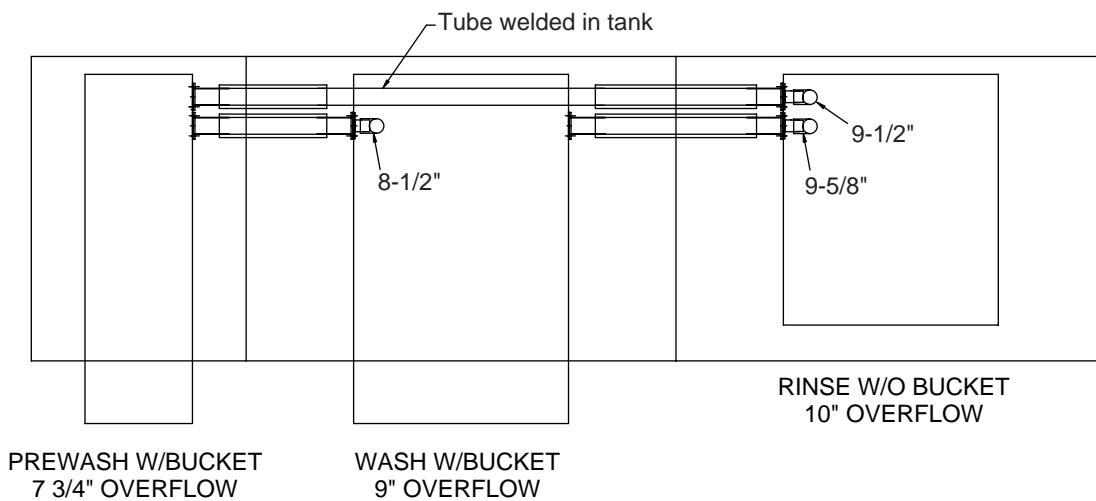
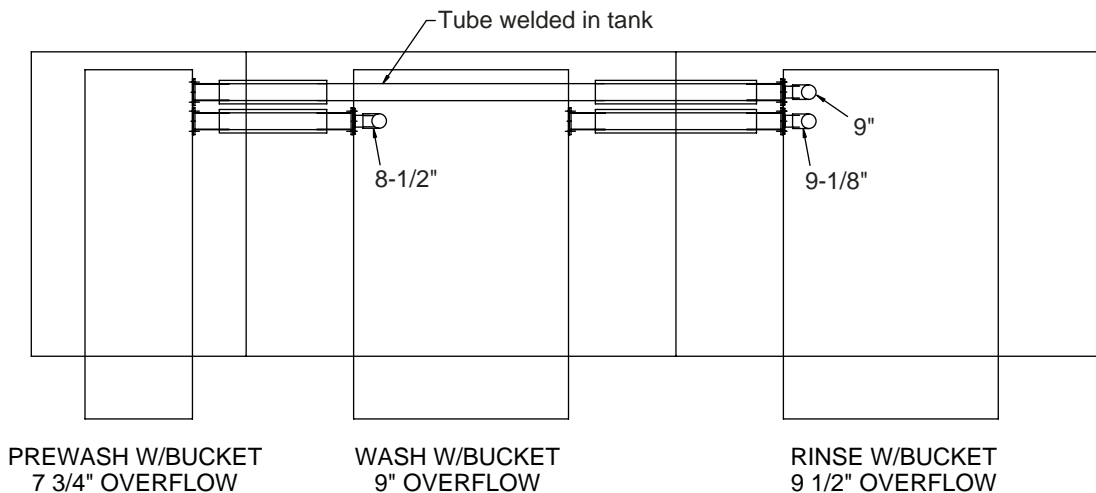

APPENDIX C (cont.)

Chart 3:

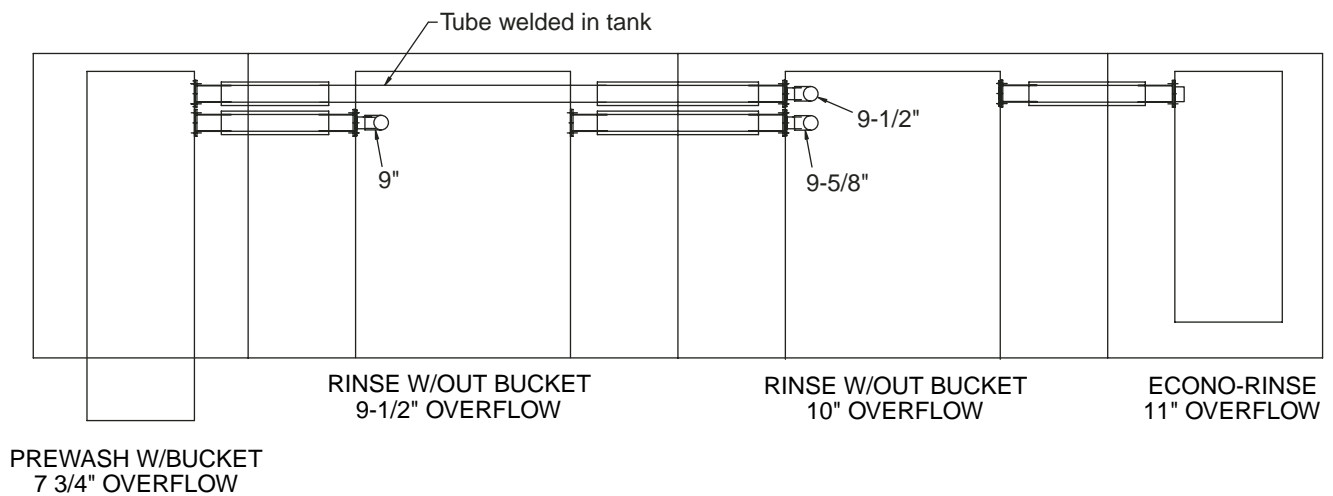
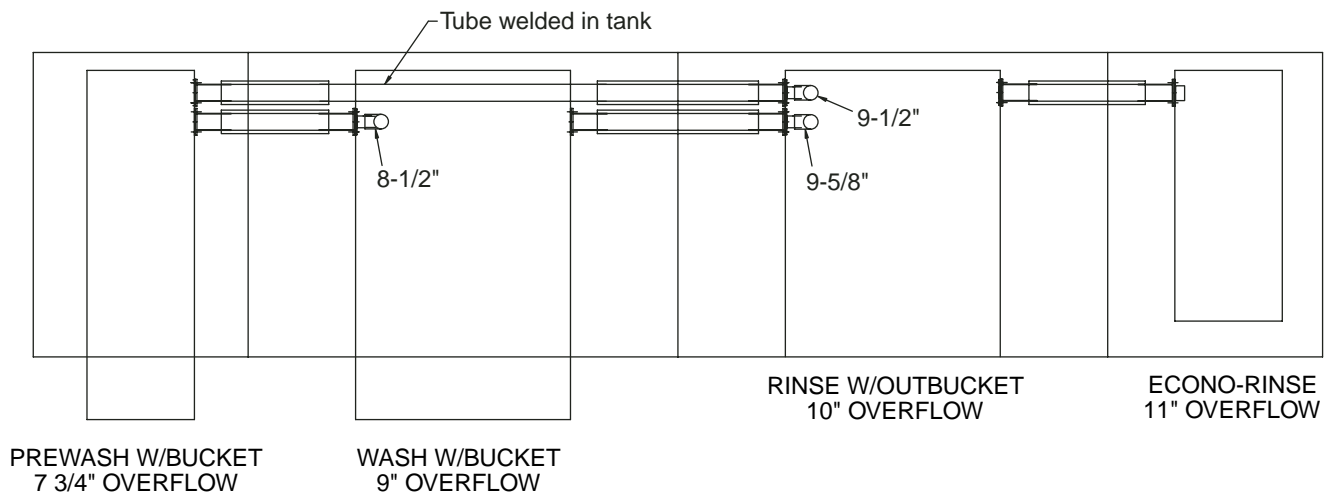
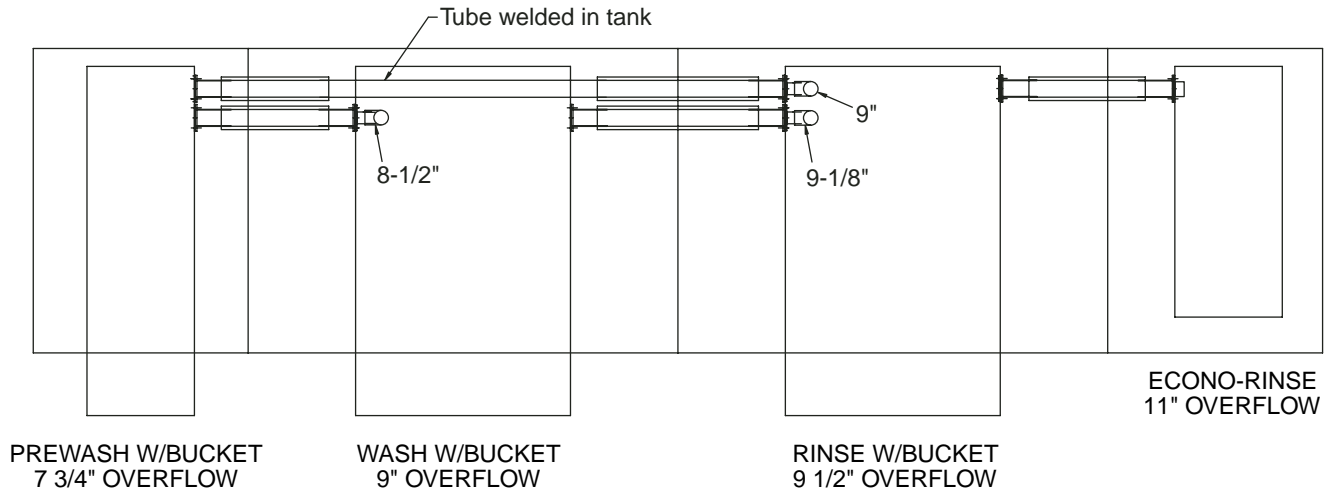

WIRING DIAGRAMS

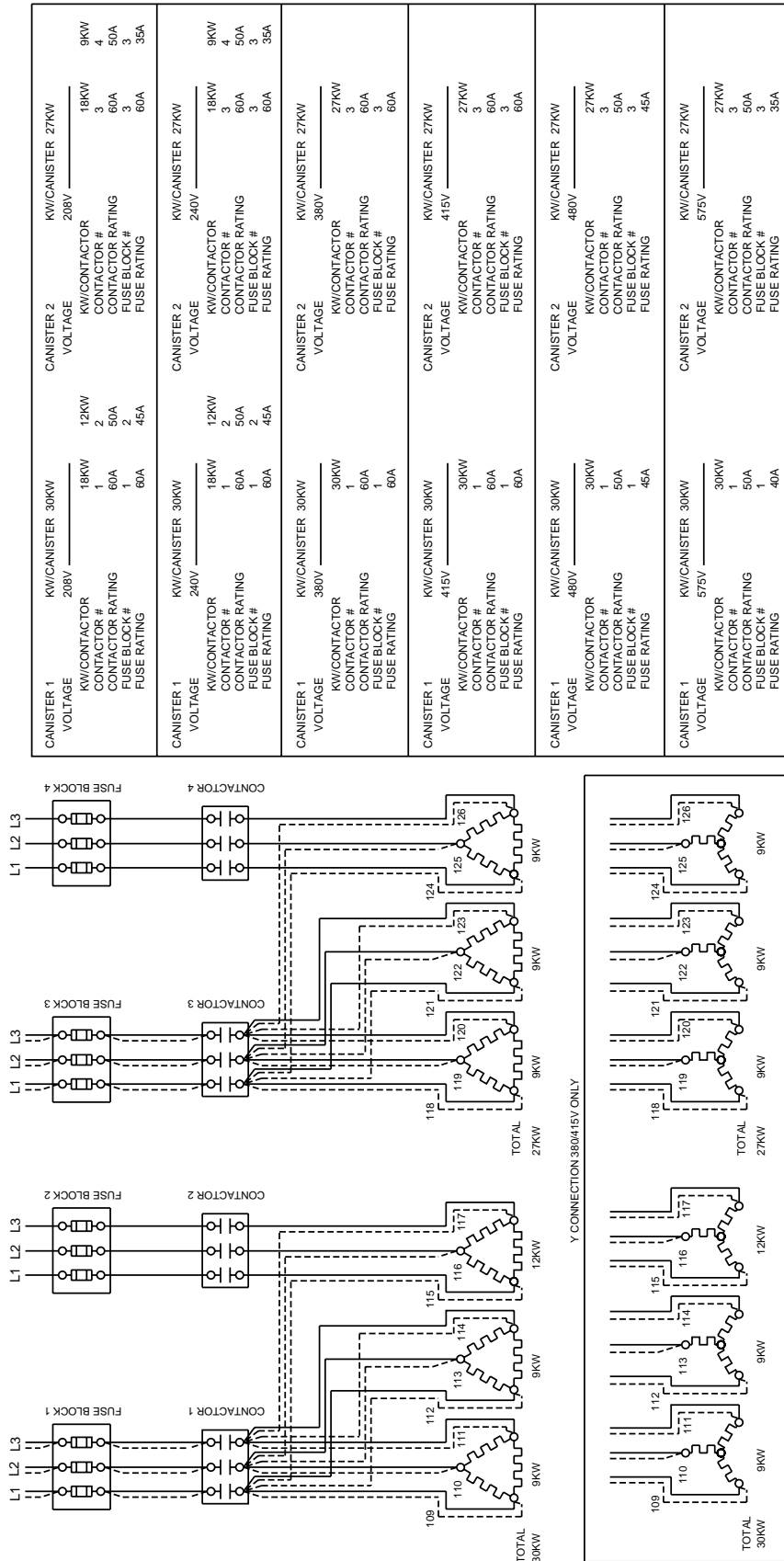

B701357/A

Figure 51 - Electric Booster - 57 KW

CANISTER 1 VOLTAGE 208V KW/CANISTER 18KW KW /CONTACTOR # 2 CONTACTOR # 60A FUSE BLOCK # 1 FUSE RATING 70A	CANISTER 2 VOLTAGE 208V KW/CANISTER 18KW KW /CONTACTOR # 2 CONTACTOR # 60A FUSE BLOCK # 1 FUSE RATING 70A	CANISTER 3 VOLTAGE 208V KW/CANISTER 18KW KW /CONTACTOR # 2 CONTACTOR # 60A FUSE BLOCK # 1 FUSE RATING 70A	CANISTER 4 VOLTAGE 208V KW/CANISTER 18KW KW /CONTACTOR # 2 CONTACTOR # 60A FUSE BLOCK # 1 FUSE RATING 70A
CANISTER 1 VOLTAGE 240V KW/CANISTER 36KW KW /CONTACTOR # 1 CONTACTOR # 90A FUSE BLOCK # 1 FUSE RATING 70A	CANISTER 2 VOLTAGE 240V KW/CANISTER 18KW KW /CONTACTOR # 2 CONTACTOR # 90A FUSE BLOCK # 1 FUSE RATING 70A	CANISTER 3 VOLTAGE 240V KW/CANISTER 18KW KW /CONTACTOR # 2 CONTACTOR # 90A FUSE BLOCK # 1 FUSE RATING 70A	CANISTER 4 VOLTAGE 240V KW/CANISTER 18KW KW /CONTACTOR # 2 CONTACTOR # 90A FUSE BLOCK # 1 FUSE RATING 70A
CANISTER 1 VOLTAGE 380V KW/CANISTER 36KW KW /CONTACTOR # 1 CONTACTOR # 50A FUSE BLOCK # 1 FUSE RATING 45A	CANISTER 2 VOLTAGE 380V KW/CANISTER 18KW KW /CONTACTOR # 2 CONTACTOR # 50A FUSE BLOCK # 1 FUSE RATING 45A	CANISTER 3 VOLTAGE 380V KW/CANISTER 18KW KW /CONTACTOR # 2 CONTACTOR # 50A FUSE BLOCK # 1 FUSE RATING 45A	CANISTER 4 VOLTAGE 380V KW/CANISTER 18KW KW /CONTACTOR # 2 CONTACTOR # 50A FUSE BLOCK # 1 FUSE RATING 45A
CANISTER 1 VOLTAGE 415V KW/CANISTER 36KW KW /CONTACTOR # 1 CONTACTOR # 50A FUSE BLOCK # 1 FUSE RATING 35A	CANISTER 2 VOLTAGE 415V KW/CANISTER 18KW KW /CONTACTOR # 2 CONTACTOR # 50A FUSE BLOCK # 1 FUSE RATING 35A	CANISTER 3 VOLTAGE 415V KW/CANISTER 18KW KW /CONTACTOR # 2 CONTACTOR # 50A FUSE BLOCK # 1 FUSE RATING 35A	CANISTER 4 VOLTAGE 415V KW/CANISTER 18KW KW /CONTACTOR # 2 CONTACTOR # 50A FUSE BLOCK # 1 FUSE RATING 35A
CANISTER 1 VOLTAGE 480V KW/CANISTER 36KW KW /CONTACTOR # 1 CONTACTOR # 60A FUSE BLOCK # 1 FUSE RATING 60A	CANISTER 2 VOLTAGE 480V KW/CANISTER 18KW KW /CONTACTOR # 2 CONTACTOR # 60A FUSE BLOCK # 1 FUSE RATING 60A	CANISTER 3 VOLTAGE 480V KW/CANISTER 18KW KW /CONTACTOR # 2 CONTACTOR # 60A FUSE BLOCK # 1 FUSE RATING 60A	CANISTER 4 VOLTAGE 480V KW/CANISTER 18KW KW /CONTACTOR # 2 CONTACTOR # 60A FUSE BLOCK # 1 FUSE RATING 60A
CANISTER 1 VOLTAGE 575V KW/CANISTER 36KW KW /CONTACTOR # 1 CONTACTOR # 50A FUSE BLOCK # 1 FUSE RATING 45A	CANISTER 2 VOLTAGE 575V KW/CANISTER 18KW KW /CONTACTOR # 2 CONTACTOR # 50A FUSE BLOCK # 1 FUSE RATING 45A	CANISTER 3 VOLTAGE 575V KW/CANISTER 18KW KW /CONTACTOR # 2 CONTACTOR # 50A FUSE BLOCK # 1 FUSE RATING 45A	CANISTER 4 VOLTAGE 575V KW/CANISTER 18KW KW /CONTACTOR # 2 CONTACTOR # 50A FUSE BLOCK # 1 FUSE RATING 45A

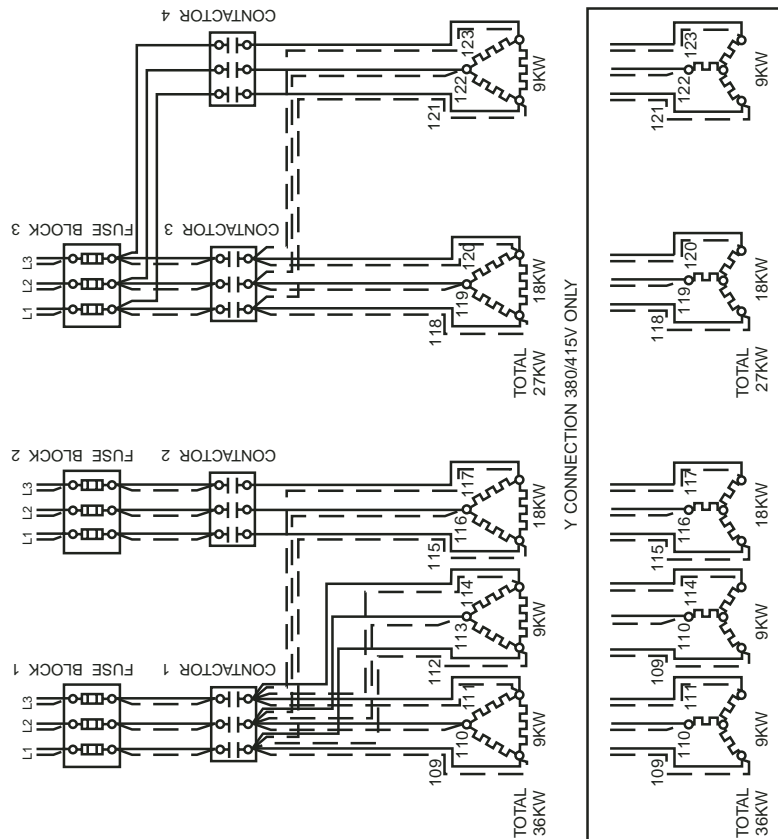
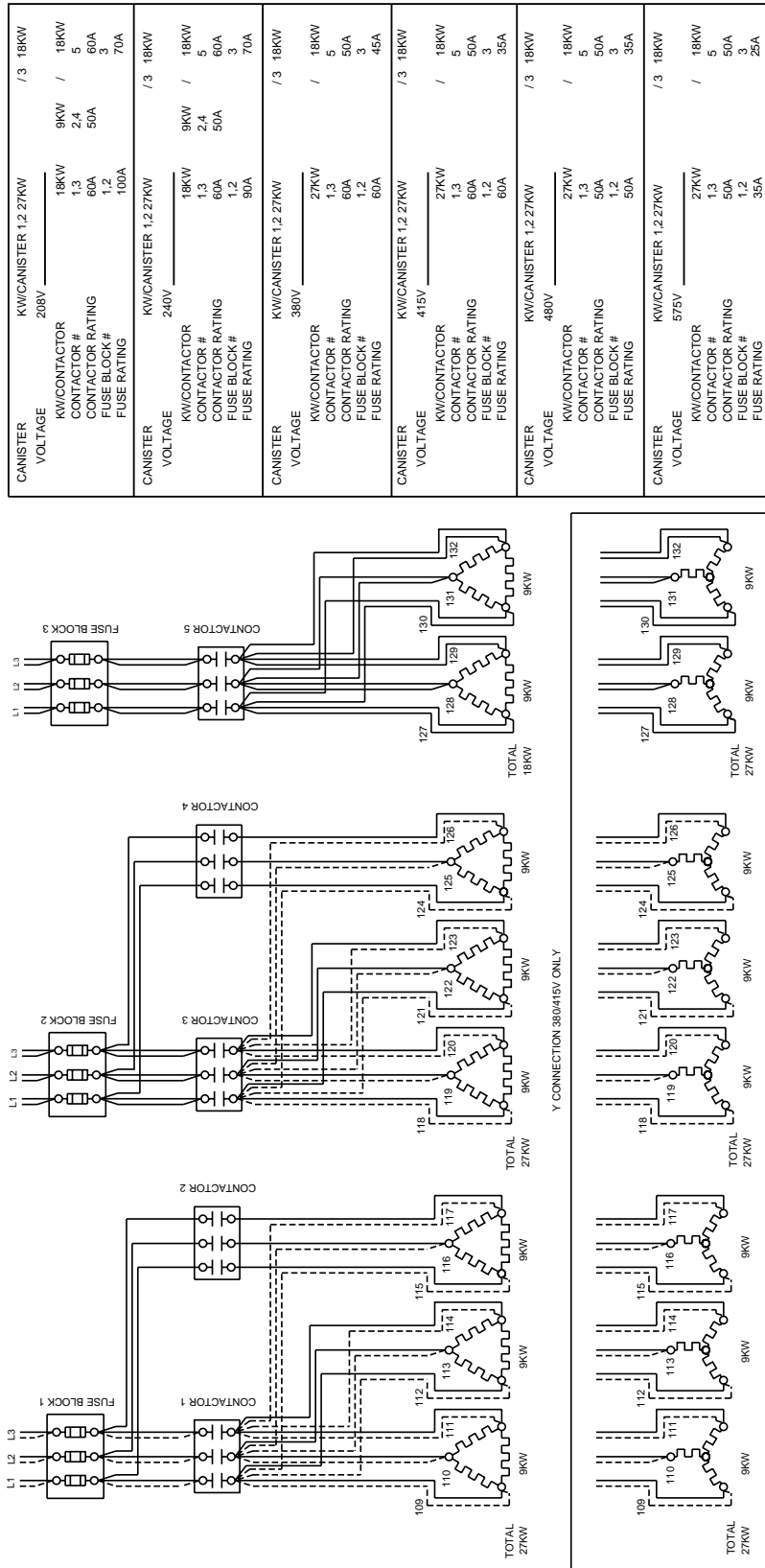

Figure 52 - Electric Booster - 63 KW



B700847/B

Figure 53 - Electric Booster - 72 KW

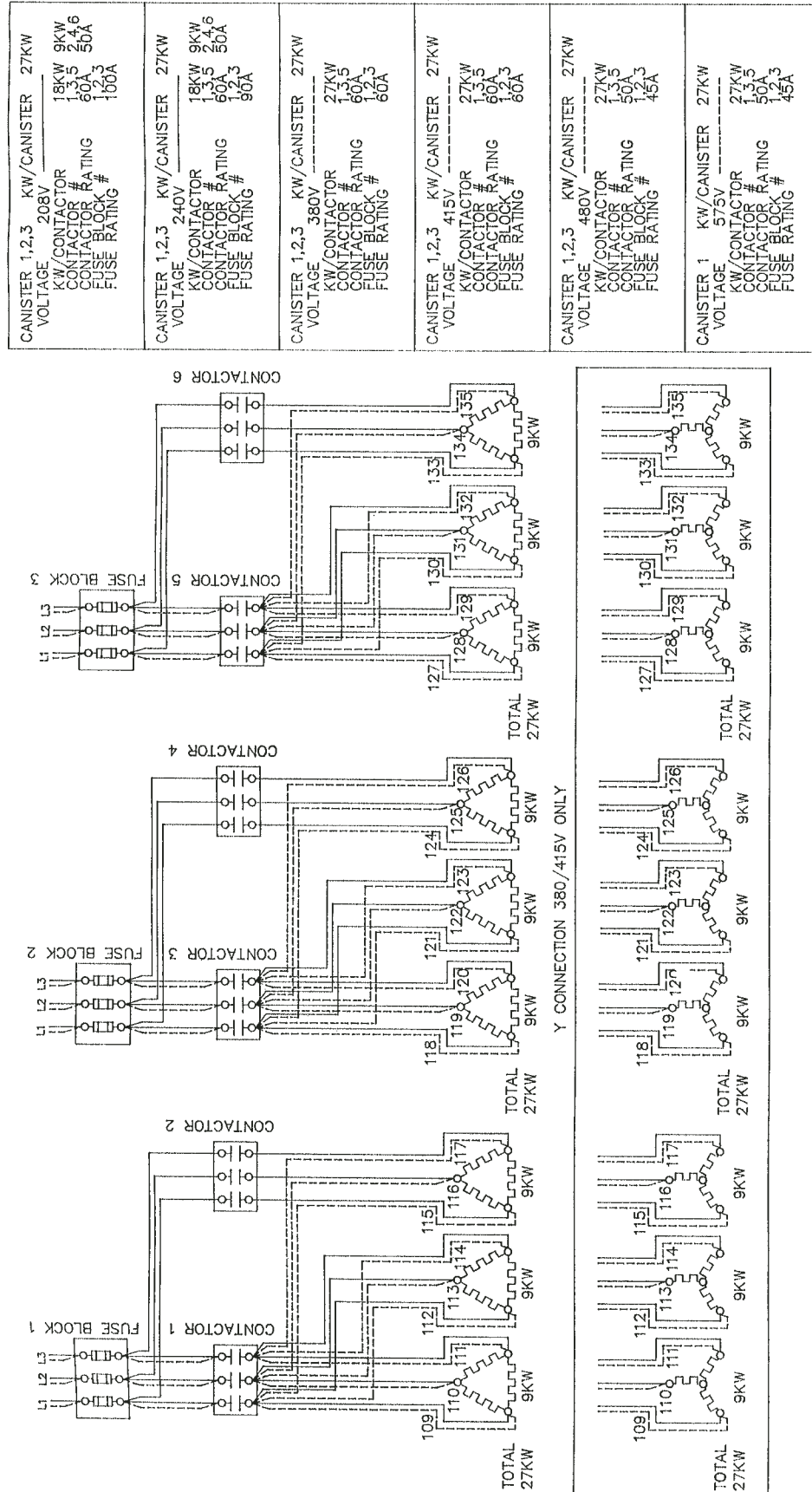
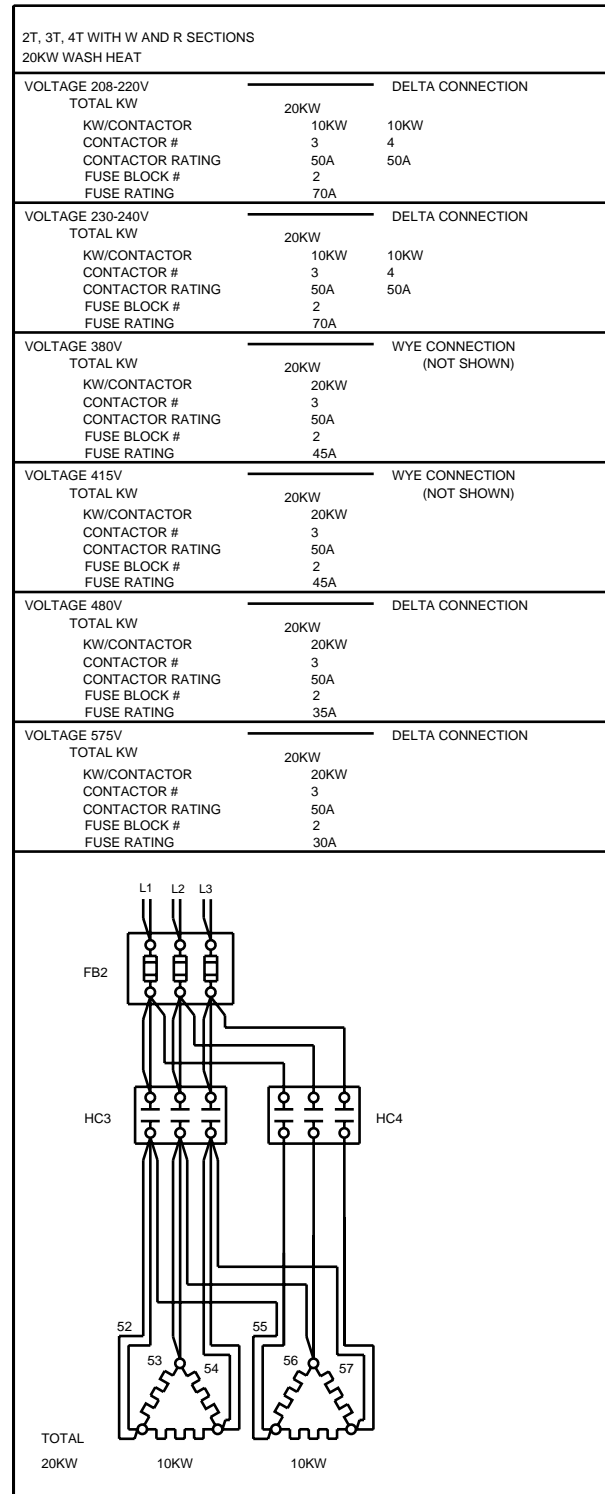
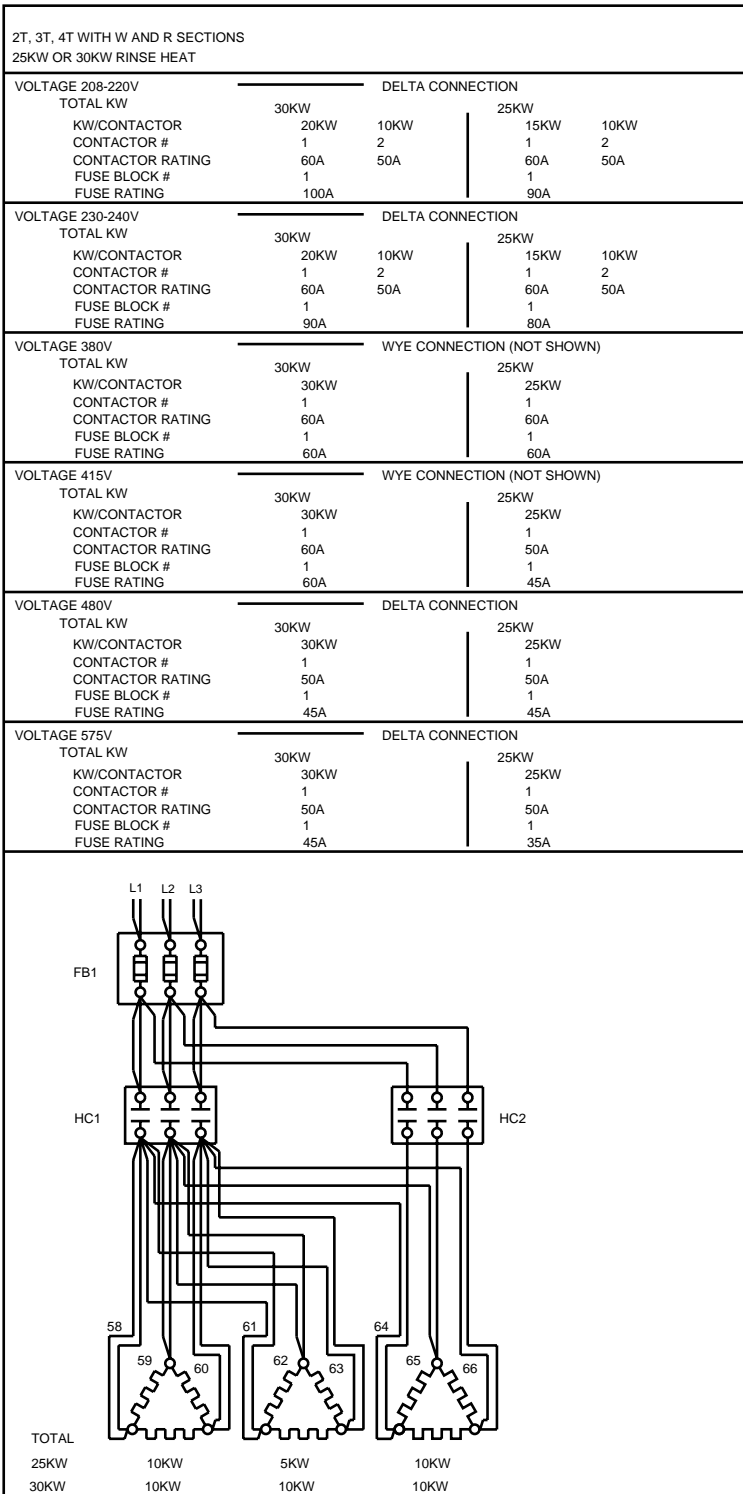

Figure 54 - Electric Booster - 81 KW

WIRING DIAGRAMS



ER	ECONO RINSE	R	RINSE TANK
FB-	FUSE BLOCK	T	MACHINE TANK
HC-	HEAT CONTACTOR	W	WASH TANK
PW	PREWASH TANK		

Figure 55 - Electric Tank Heat

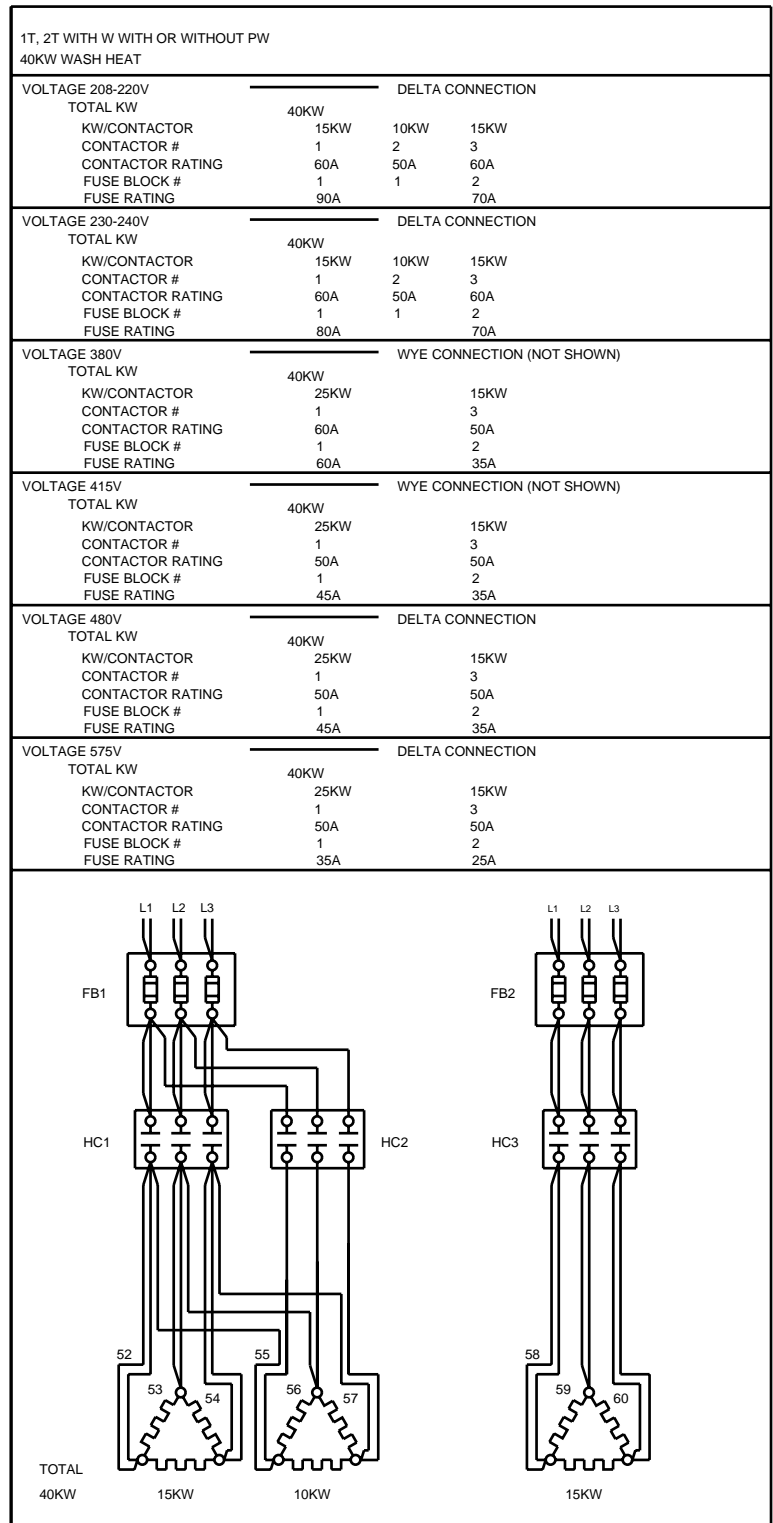
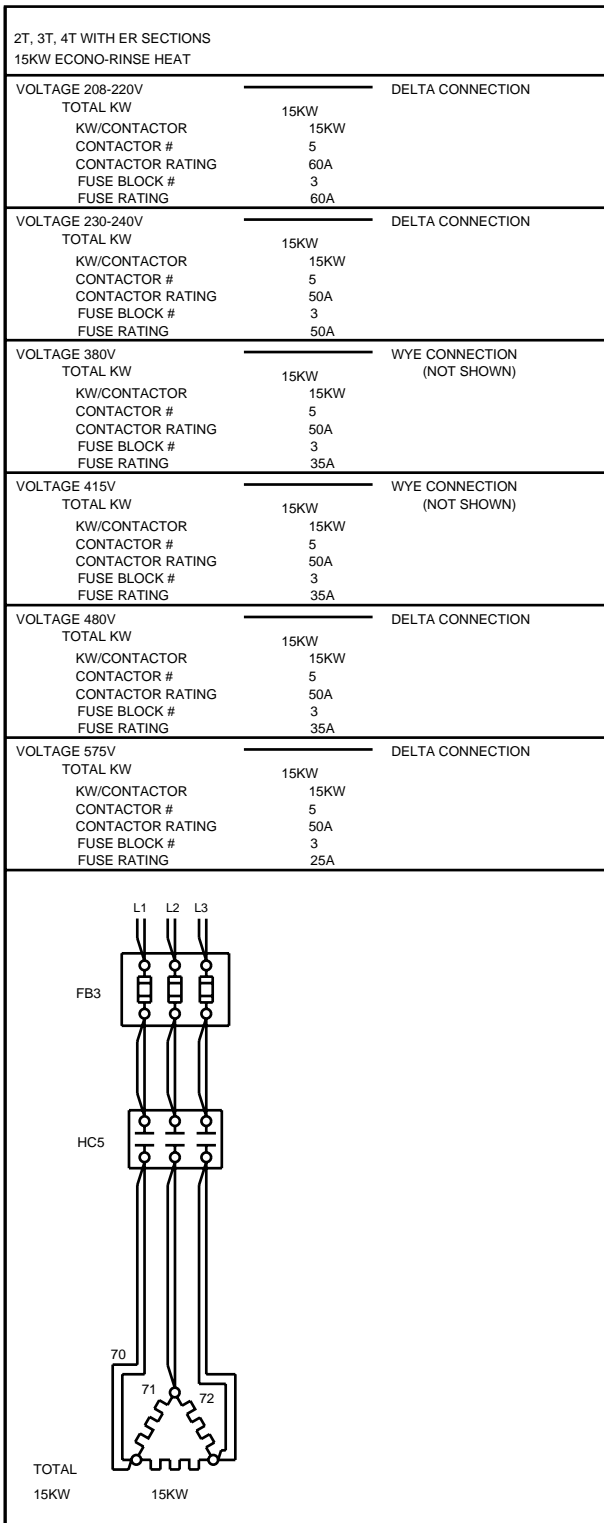

B752512/D

ER	ECONO RINSE	R	RINSE TANK
FB-	FUSE BLOCK	T	MACHINE TANK
HC-	HEAT CONTACTOR	W	WASH TANK
PW	PREWASH TANK		

Figure 55 - Electric Tank Heat (cont'd)

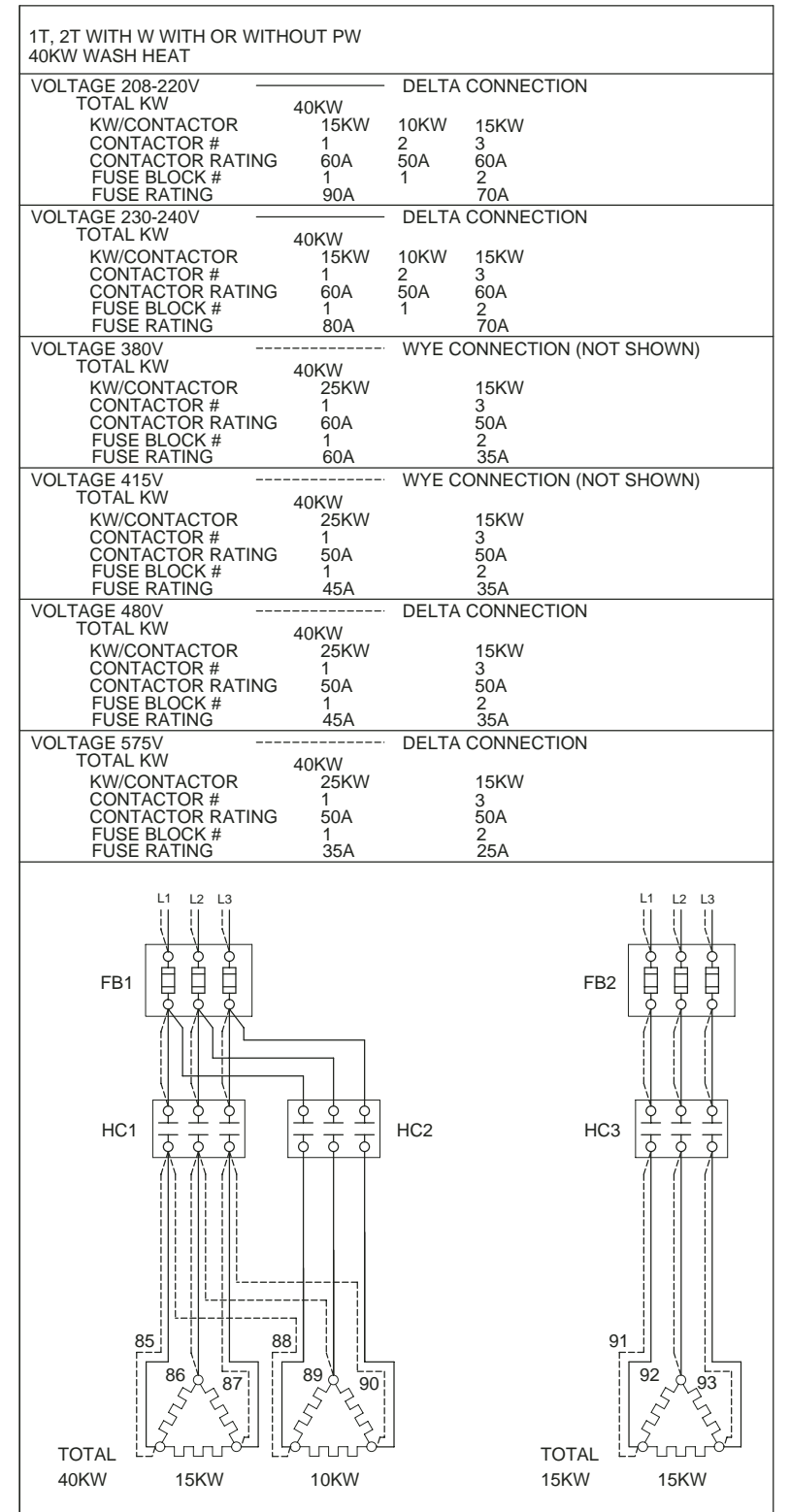
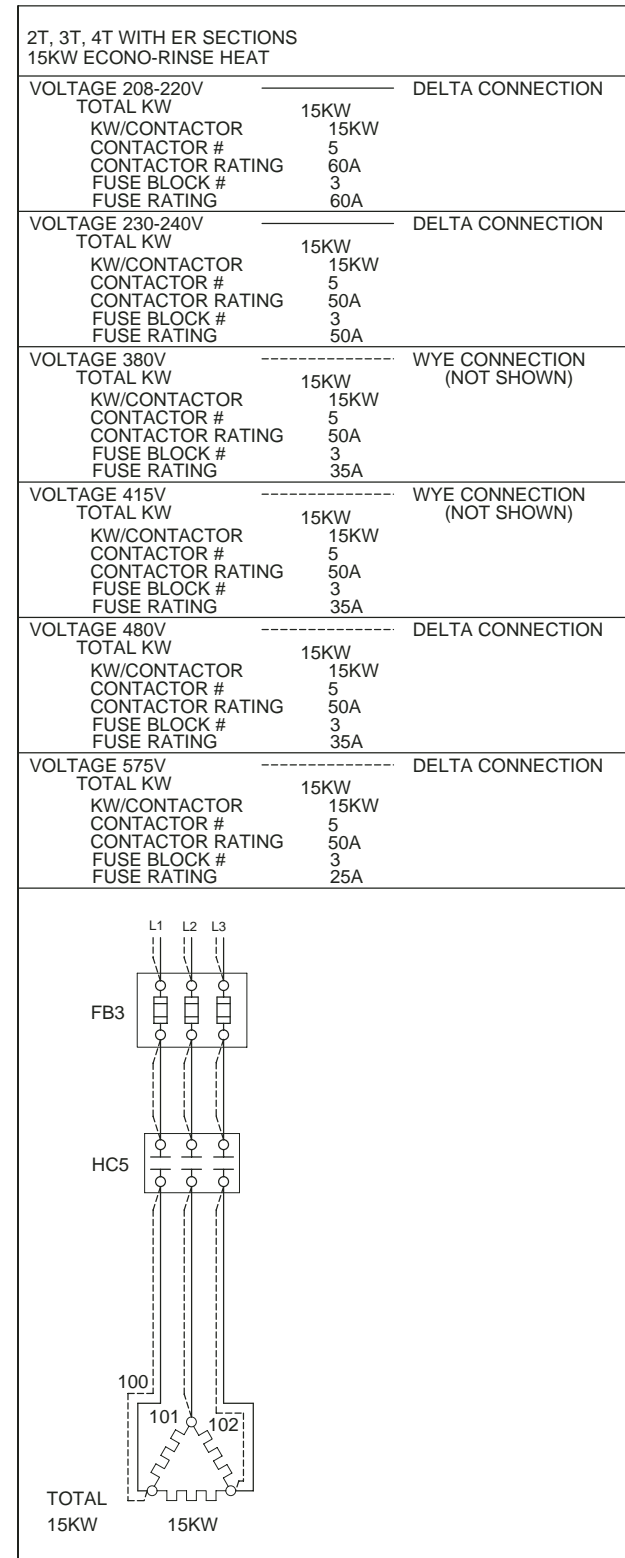
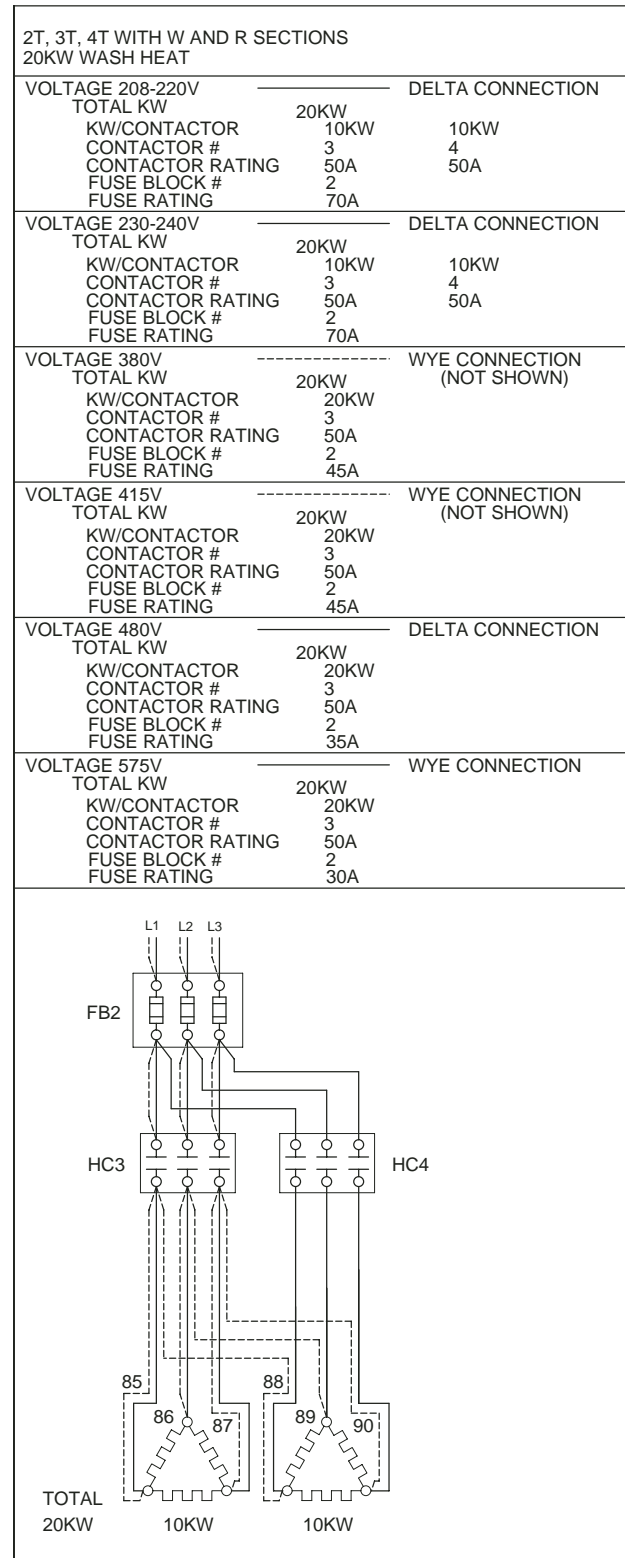
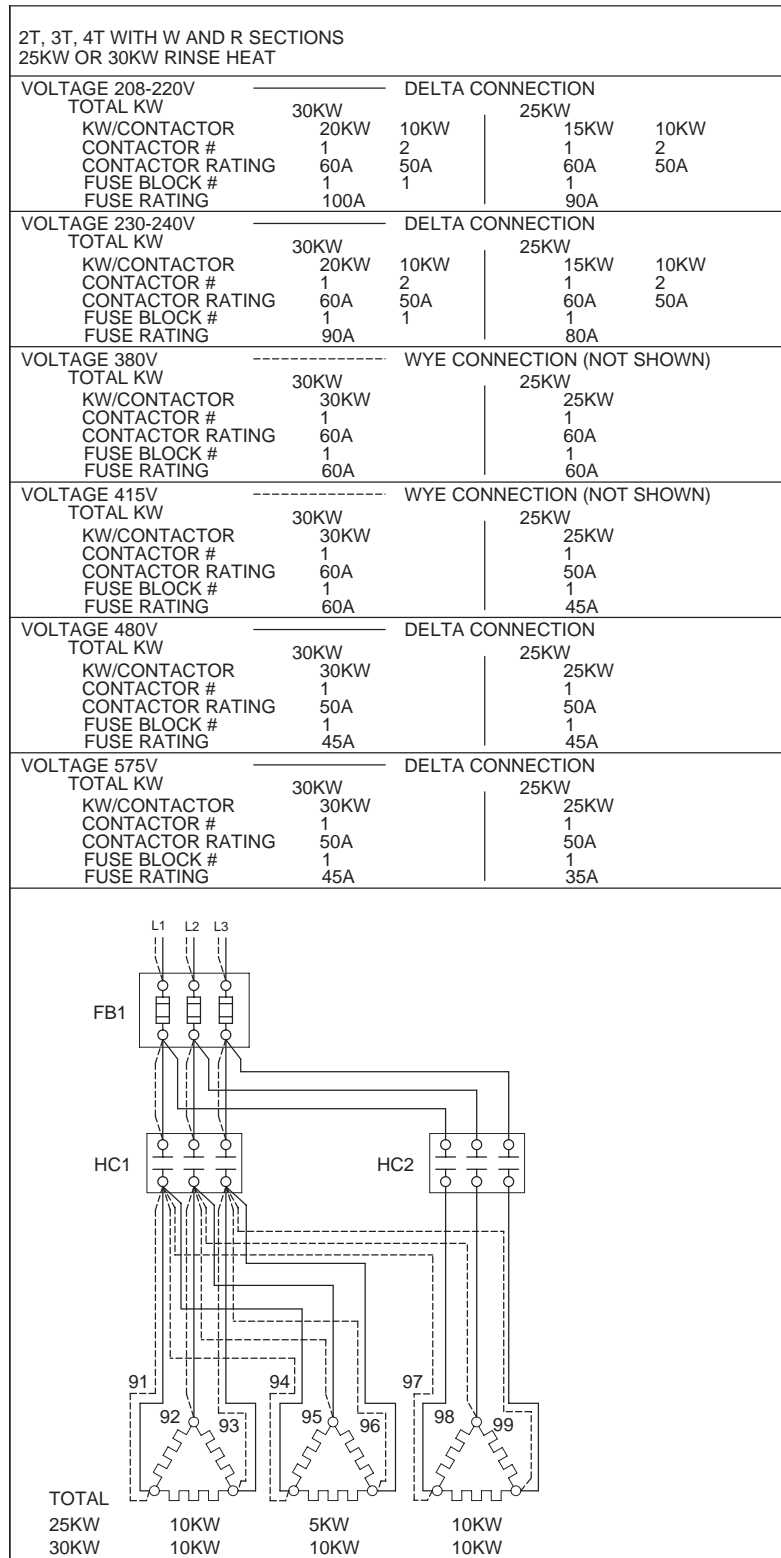

ER	ECONO RINSE	R	RINSE TANK
FB-	FUSE BLOCK	T	MACHINE TANK
HC-	HEAT CONTACTOR	W	WASH TANK
PW	PREWASH TANK		

UC TANK HEAT
ELECTRIC
#701399

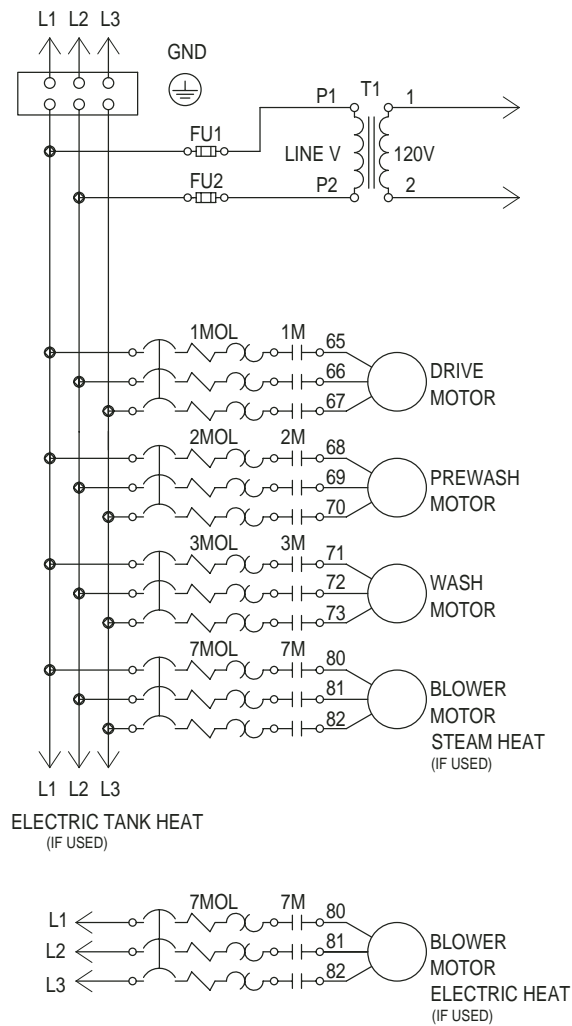
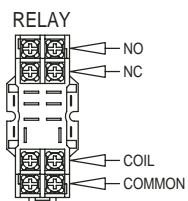
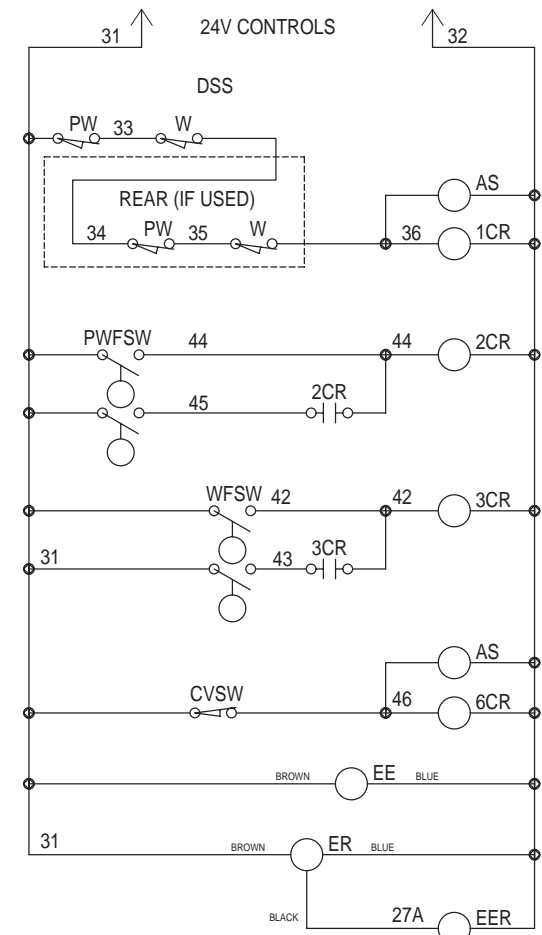
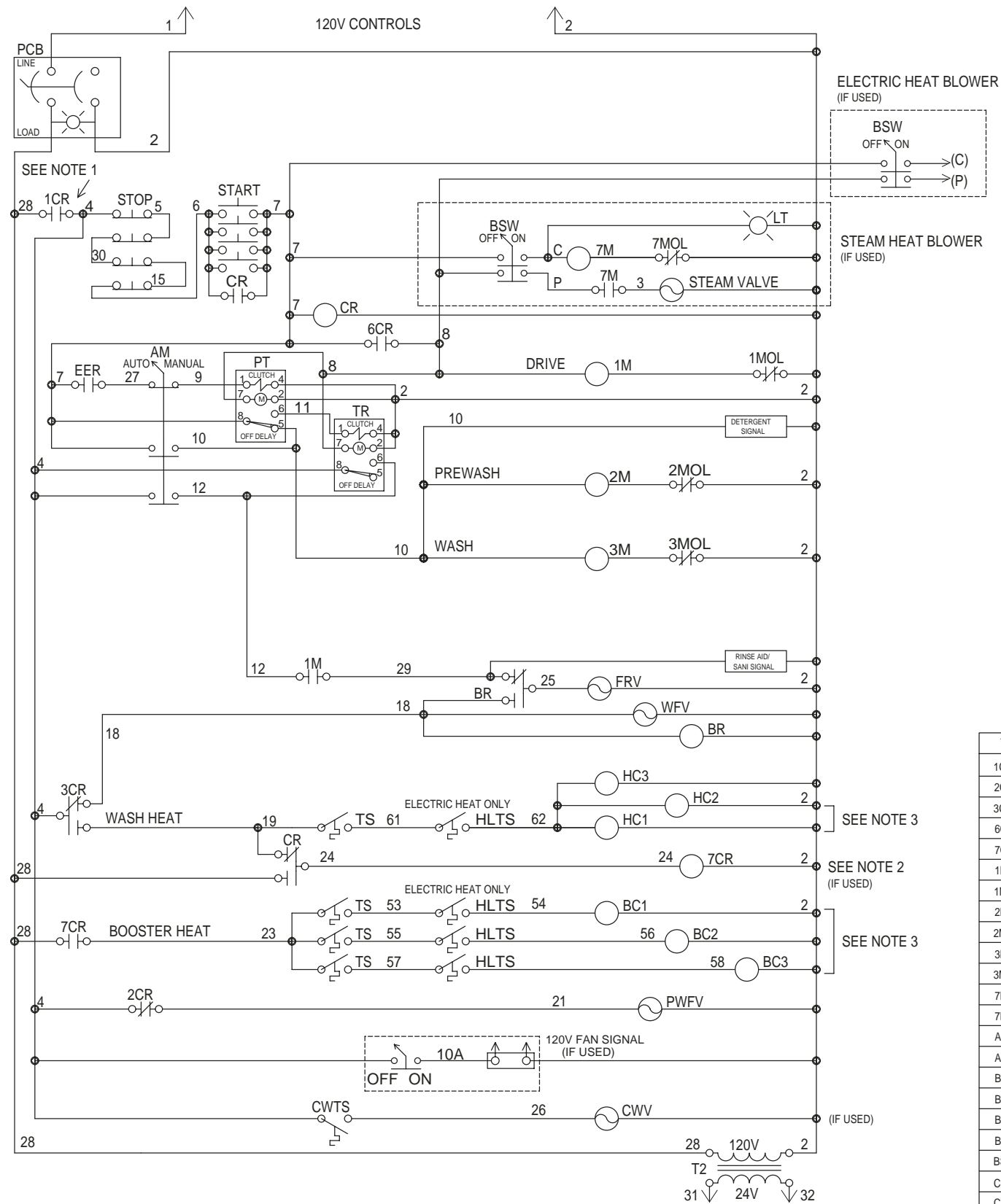

DIAGRAM STATE
POWER OFF
DOORS CLOSED
TANKS EMPTY



NOTES:

- IF DSS (1CR) IS NOT USED, CONNECT WIRES #4 TO #28
- 7CR RELAY AND CR CONTACT ONLY USED WITH BOOSTER
- WHEN STEAM HEAT IS USED- HC1, BC1 ARE STEAM VALVES, HC2, HC4, BC2, BC3 ARE NOT USED
WHEN ELECTRIC HEAT IS USED- HC1 THRU 3, BC1 THRU 3 ARE ELECTRIC CONTACTORS



* COMPONENT LOCATED IN MAIN CONTROL CABINET			
1CR	* DOOR SAFETY HOLD IN RELAY	DSS	DOOR SAFETY SWITCH
2CR	* PREWASH FILL SWITCH RELAY	EE	ELECTRIC EYE EMITTER
3CR	* WASH FILL SWITCH RELAY	ER	ELECTRIC EYE RECEIVER
6CR	* CONVEYOR SWITCH RELAY	EER	* ELECTRIC EYE RELAY
7CR	* BOOSTER HEAT HOLD IN RELAY	FU1	* FUSE-PRIMARY SIDE OF TRANSFORMER
1M	* DRIVE MOTOR CONTACTOR	FU2	* FUSE-PRIMARY SIDE OF TRANSFORMER
1MOL	* DRIVE MOTOR OVERLOAD	FRV	FINAL RINSE AND RINSE TANK FILL VALVE
2M	* PREWASH MOTOR CONTACTOR	FV	FLUSHING VALVE
2MOL	* PREWASH MOTOR OVERLOAD	GND	* GROUND
3M	* WASH MOTOR CONTACTOR	HC1	* WASH TANK ELECTRIC HEAT CONTACTOR OR STEAM VALVE
3MOL	* WASH MOTOR OVERLOAD	HC2	* WASH TANK CONTACTOR-ELECTRIC HEAT ONLY
7M	* STEAM HEAT BLOWER MOTOR CONTACTOR	HC3	* WASH TANK ELECTRIC HEAT CONTACTOR OR STEAM VALVE
7MOL	* STEAM HEAT BLOWER MOTOR OVERLOAD	HLTS	HIGH LIMIT THERMOSTAT-ELECTRIC HEAT ONLY
AM	* AUTO-MANUAL MODE SWITCH (ELECTRIC EYE/TIMER BYPASS)	PCB	* POWER SWITCH/CIRCUIT BREAKER/POWER ON LIGHT
AS	* ARC SUPPRESSOR	PT	* PUMP TIMER
BC1	BOOSTER ELECTRIC HEAT CONTACTORS OR STEAM VALVE	PWFSW	RINSE TANK FLOAT SWITCH
BC2	BOOSTER TANK CONTACTORS-ELECTRIC HEAT ONLY	PWFV	RINSE TANK FILL VALVE
BC3	BOOSTER TANK CONTACTORS-ELECTRIC HEAT ONLY	T1	* CONTROL TRANSFORMER - LINE V:120V
BR	* RINSE AID SIGNAL RELAY	T2	* CONTROL TRANSFORMER - 120V:24V
BSW	* BLOWER SWITCH	TR	* FINAL RINSE TIMER
CR	* HOLD-IN RELAY	TS	THERMOSTAT
CVSW	CONVEYOR SWITCH	WFSW	WASH TANK FLOAT SWITCH
CWTS	COLD WATER THERMOSTAT	WFV	WASH TANK FILL VALVE
CWV	COLD WATER VALVE		

CUSTOMER TO SUPPLY RATED VOLTAGE/PHASE/Hz AS SPECIFIED PER ORDER, TO DISCONNECT SWITCH. ALL POWER SUPPLIED TO EACH CONNECTION POINT MUST COMPLY WITH ALL LOCAL ELECTRICAL CODES.			
DR. BY	J. NEWTON	SCALE	NONE
DATE	17SEPT99	SHEET	1 OF 1

REV.	DESCRIPTION	DATE	BY
A	CORRECTED FLOAT CONTACTS	23JULY01	JCN
B	ADDED REAR DOORS, ARC SUPPRESSORS	21SEPT01	JCN
C	ADDED VENT FAN CIRCUITRY	20DEC01	JCN

REV.	DESCRIPTION	DATE	BY

The Dishwashing Machine Specialists

**UC-2T PREWASH-WASH NUCCW
STEAM/ELECTRIC-STANDARD**

B **701669** **C**

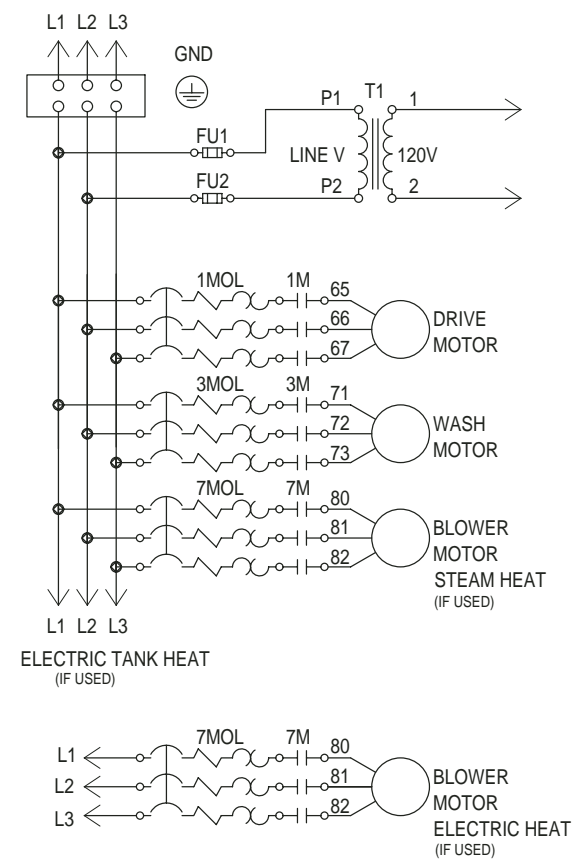
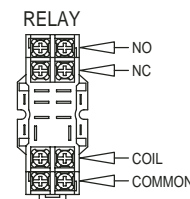

DIAGRAM STATE

POWER OFF
DOORS CLOSED
TANKS EMPTY



NOTES:

- IF DSS (1CR) IS NOT USED, CONNECT WIRES #4 TO #28
- 7CR RELAY AND CR CONTACT ONLY USED WITH BOOSTER
- WHEN STEAM HEAT IS USED- HC1, BC1 ARE STEAM VALVES, HC2, HC4, BC2, BC3 ARE NOT USED
WHEN ELECTRIC HEAT IS USED- HC1 THRU 3, BC1 THRU 3 ARE ELECTRIC CONTACTORS

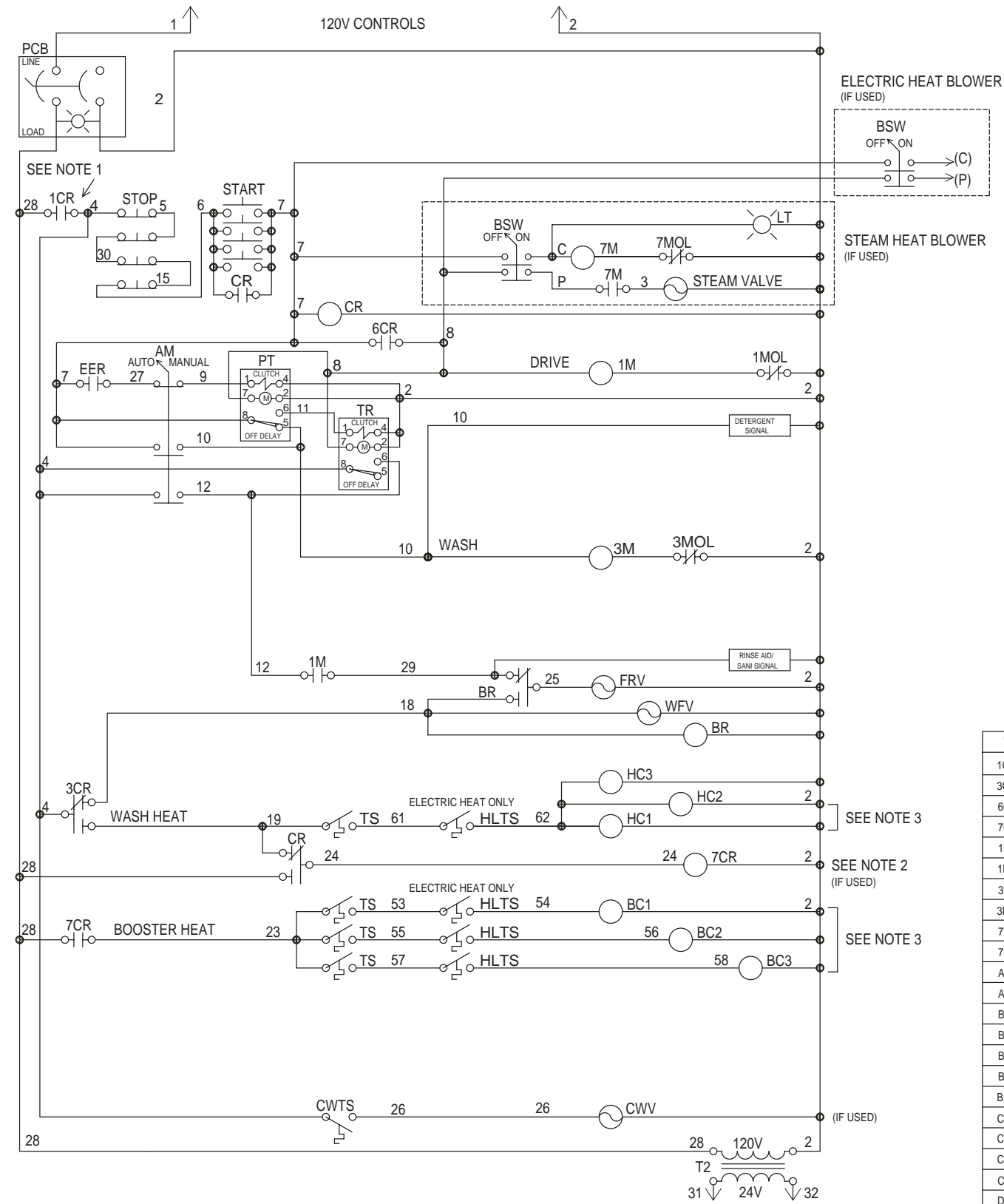

ELECTRIC HEAT BLOWER (IF USED)

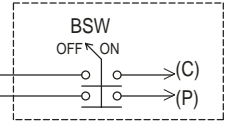

STEAM HEAT BLOWER (IF USED)

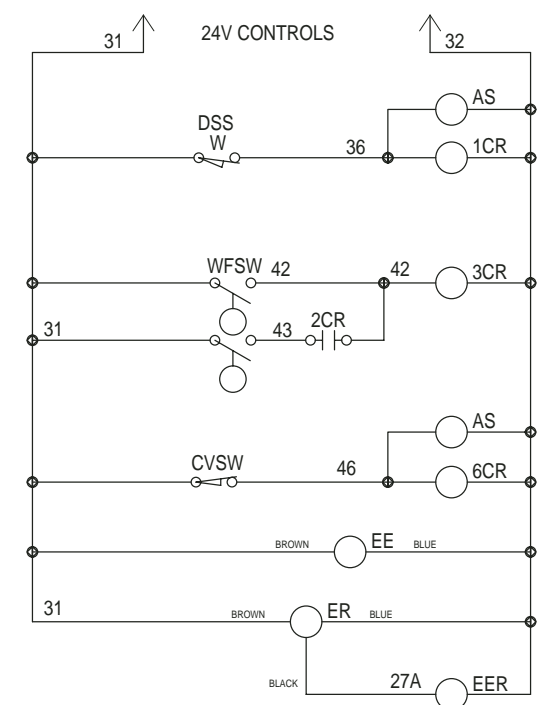

* COMPONENT LOCATED IN MAIN CONTROL CABINET			
1CR	* DOOR SAFETY HOLD IN RELAY	EE	ELECTRIC EYE EMITTER
3CR	* WASH FILL SWITCH RELAY	ER	ELECTRIC EYE RECEIVER
6CR	* CONVEYOR SWITCH RELAY	EER	* ELECTRIC EYE RELAY
7CR	* BOOSTER HEAT HOLD IN RELAY	FU1	* FUSE-PRIMARY SIDE OF TRANSFORMER
1M	* DRIVE MOTOR CONTACTOR	FU2	* FUSE-PRIMARY SIDE OF TRANSFORMER
1MOL	* DRIVE MOTOR OVERLOAD	FRV	FINAL RINSE AND RINSE TANK FILL VALVE
3M	* WASH MOTOR CONTACTOR	FV	FLUSHING VALVE
3MOL	* WASH MOTOR OVERLOAD	GND	* GROUND
7M	* STEAM HEAT BLOWER MOTOR CONTACTOR	HC1	* WASH TANK ELECTRIC HEAT CONTACTOR OR STEAM VALVE
7MOL	* STEAM HEAT BLOWER MOTOR OVERLOAD	HC2	* WASH TANK CONTACTOR-ELECTRIC HEAT ONLY
AM	* AUTO-MANUAL MODE SWITCH (ELECTRIC EYE/TIMER BYPASS)	HC3	* WASH TANK ELECTRIC HEAT CONTACTOR OR STEAM VALVE
AS	* ARC SUPPRESSOR	HLTS	HIGH LIMIT THERMOSTAT-ELECTRIC HEAT ONLY
BC1	BOOSTER ELECTRIC HEAT CONTACTORS OR STEAM VALVE	PCB	* POWER SWITCH/CIRCUIT BREAKER/POWER ON LIGHT
BC2	BOOSTER TANK CONTACTORS-ELECTRIC HEAT ONLY	PT	* PUMP TIMER
BC3	BOOSTER TANK CONTACTORS-ELECTRIC HEAT ONLY	T1	* CONTROL TRANSFORMER - LINE V:120V
BR	* RINSE AID SIGNAL RELAY	T2	* CONTROL TRANSFORMER - 120V:24V
BSW	* BLOWER SWITCH	TR	* FINAL RINSE TIMER
CR	* HOLD-IN RELAY	TS	THERMOSTAT
CVSW	CONVEYOR SWITCH	WFSW	WASH TANK FLOAT SWITCH
CWTS	COLD WATER THERMOSTAT	WFV	WASH TANK FILL VALVE
CWV	COLD WATER VALVE		
DSS	DOOR SAFETY SWITCH		

CUSTOMER TO SUPPLY RATED VOLTAGE/PHASE/Hz, AS SPECIFIED PER ORDER, TO DISCONNECT SWITCH. ALL POWER SUPPLIED TO EACH CONNECTION POINT MUST COMPLY WITH ALL LOCAL ELECTRIC CODES.			
DR. BY	J. NEWTON	SCALE	NONE
DATE	17SEPT99	SHEET	1 OF 1

REV.	DESCRIPTION	DATE	BY
A	ADDED ARC SUPPRESSORS	4OCT01	JCN

REV.	DESCRIPTION	DATE	BY

Champion
The Dishwashing Machine Specialists

UC-1T NUCCW
STEAM/ELECTRIC-STANDARD
B 701670 REV. A

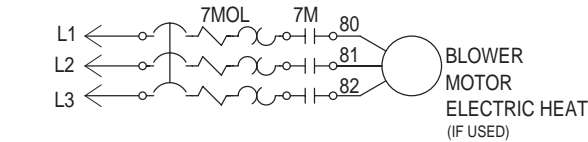
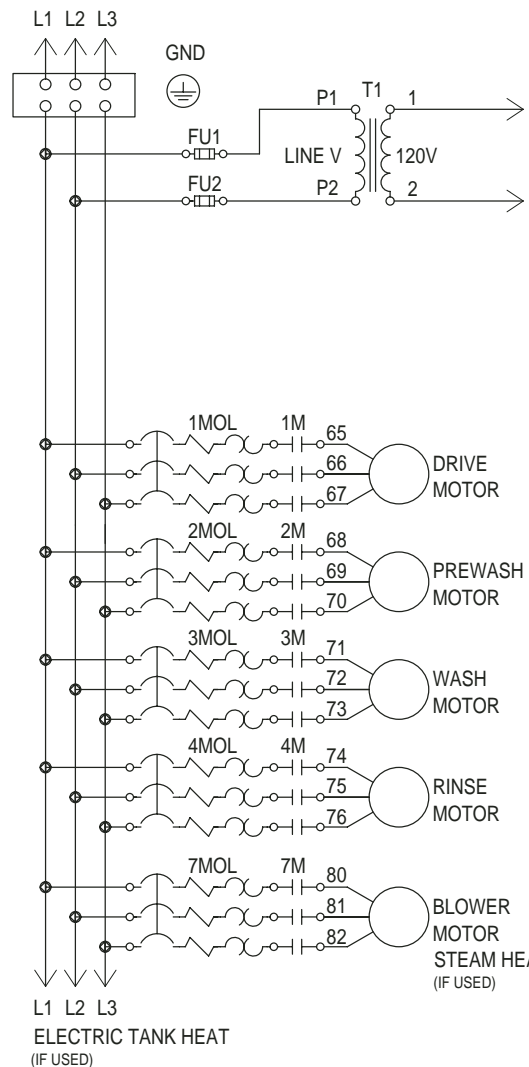
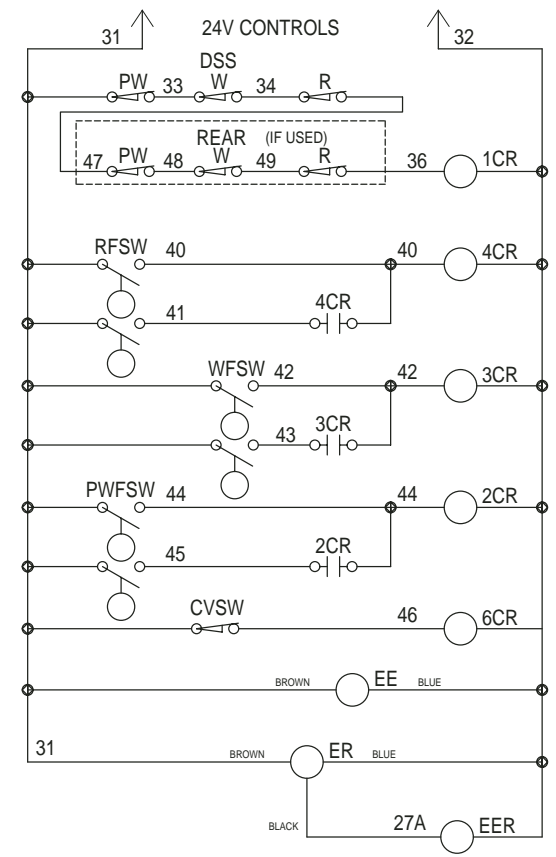
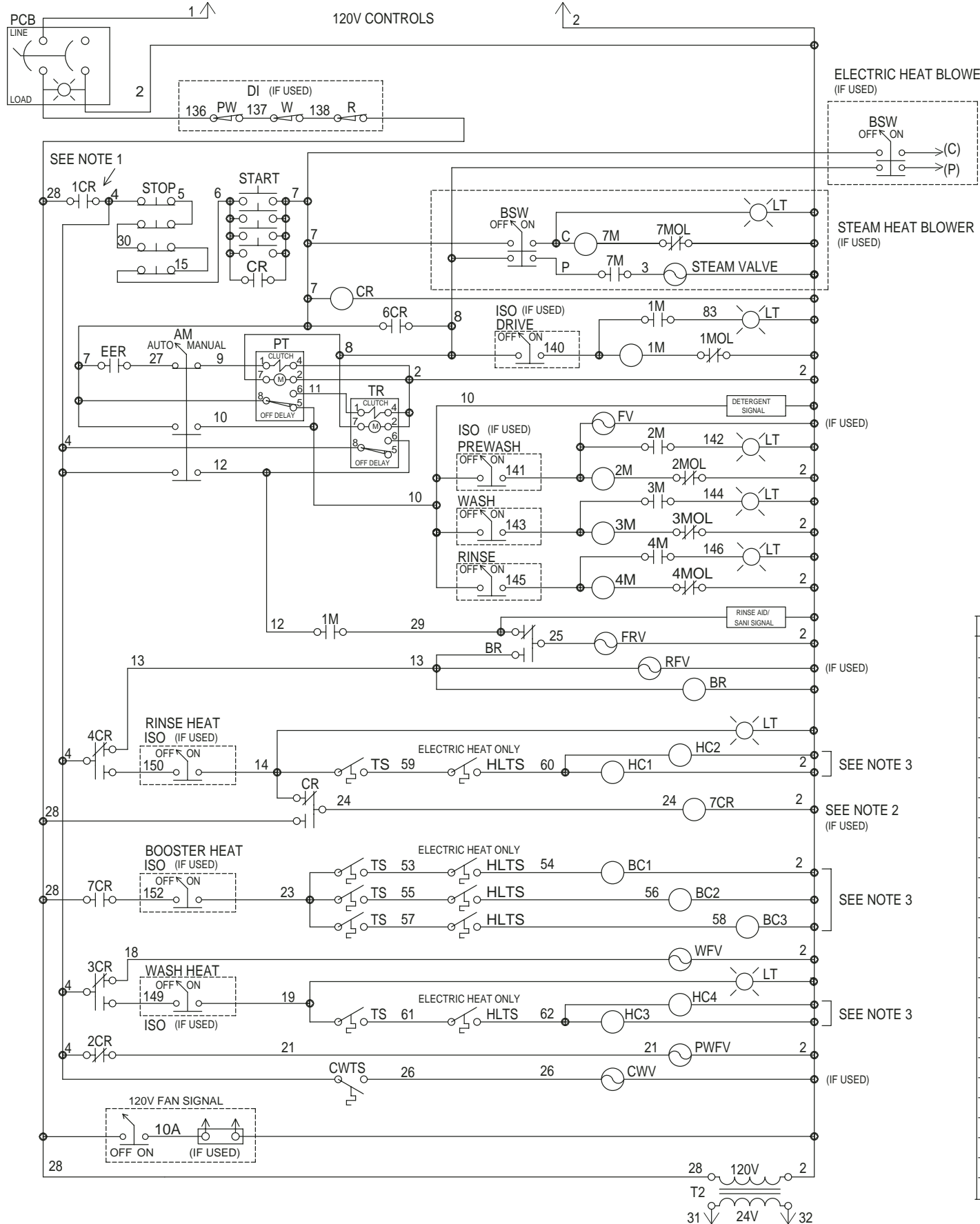
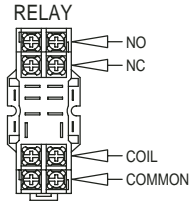

DIAGRAM STATE
POWER OFF
DOORS CLOSED
TANKS EMPTY

- NOTES:
- IF DSS (1CR) IS NOT USED, CONNECT WIRES #4 TO #28
 - 7CR RELAY AND CR CONTACT ONLY USED WITH BOOSTER
 - WHEN STEAM HEAT IS USED- HC1, HC3, BC1 ARE STEAM VALVES, HC2, HC4, BC2, BC3 ARE NOT USED
WHEN ELECTRIC HEAT IS USED- HC1 THRU 4, BC1 THRU 3 ARE ELECTRIC CONTACTORS



* COMPONENT LOCATED IN MAIN CONTROL CABINET			
1CR	* DOOR SAFETY HOLD IN RELAY	EE	ELECTRIC EYE EMMITER
2CR	* PREWASH FILL SWITCH RELAY	EER	ELECTRIC EYE RECEIVER
3CR	* WASH FILL SWITCH RELAY	ER	ELECTRIC EYE RELAY
4CR	* RINSE FILL SWITCH RELAY	FU1-2	* FUSE-PRIMARY SIDE OF TRANSFORMER
6CR	* CONVEYOR SWITCH RELAY	FU3-4	* FUSE-DC DRIVE CONTROLLER
7CR	* BOOSTER HEAT HOLD IN RELAY	FRV	FINAL RINSE AND RINSE TANK FILL VALVE
1M	* DRIVE MOTOR CONTACTOR	FV	FLUSHING VALVE
1MOL	* DRIVE MOTOR OVERLOAD	GND	* GROUND
2M	* PREWASH MOTOR CONTACTOR	HC1	* RINSE TANK ELECTRIC HEAT CONTACTOR OR STEAM VALVE
2MOL	* PREWASH MOTOR OVERLOAD	HC2	* RINSE TANK CONTACTOR-ELECTRIC HEAT ONLY
3M	* WASH MOTOR CONTACTOR	HC3	* WASH TANK ELECTRIC HEAT CONTACTOR OR STEAM VALVE
3MOL	* WASH MOTOR OVERLOAD	HC4	* WASH TANK CONTACTOR-ELECTRIC HEAT ONLY
4M	* RINSE MOTOR CONTACTOR	HLTS	HIGH LIMIT THERMOSTAT-ELECTRIC HEAT ONLY
4MOL	* RINSE MOTOR OVERLOAD	ISO	* ISOLATION SWITCH
7M	* STEAM HEAT BLOWER MOTOR CONTACTOR	LT	* ISOLATION SWITCH LIGHT
7MOL	* STEAM HEAT BLOWER MOTOR OVERLOAD	PCB	* POWER SWITCH/CIRCUIT BREAKER/POWER ON LIGHT
AM	* AUTO-MANUAL MODE SWITCH (ELECTRIC EYE/TIMER BYPASS)	PT	* PUMP TIMER
BC1	BOOSTER ELECTRIC HEAT CONTACTORS OR STEAM VALVE	PWFV	PREWASH TANK FILL VALVE
BC2	BOOSTER TANK CONTACTORS-ELECTRIC HEAT ONLY	PWFSW	PREWASH TANK FLOAT SWITCH
BC3	BOOSTER TANK CONTACTORS-ELECTRIC HEAT ONLY	RFV	RINSE TANK FILL VALVE
BR	* RINSE AID SIGNAL RELAY	RFSW	RINSE TANK FLOAT SWITCH
BSW	* BLOWER SWITCH	T1	CONTROL TRANSFORMER - LINE V:120V
CR	* HOLD-IN RELAY	T2	* CONTROL TRANSFORMER - 120V:24V
CVSW	CONVEYOR SWITCH	TR	* FINAL RINSE TIMER
CWTS	COLD WATER THERMOSTAT	TS	THERMOSTAT
CWV	COLD WATER VALVE	WFSW	WASH TANK FLOAT SWITCH
DI	DRAIN INTERLOCK	WFV	WASH TANK FILL VALVE
DSS	DOOR SAFETY SWITCH		

CUSTOMER TO SUPPLY RATED VOLTAGE/PHASE/Hz, AS SPECIFIED PER ORDER, TO DISCONNECT SWITCH. ALL POWER SUPPLIED TO EACH CONNECTION POINT MUST COMPLY WITH ALL LOCAL ELECTRIC CODES.			
DR. BY	J. NEWTON	SCALE	NONE
DATE	25JUNE97	SHEET	1 OF 1

REV.	DESCRIPTION	DATE	BY
B	ADDED DRAIN INTERLOCK AND ISO SWITCHES	4NOV99	JCN
C	ADDED ISO LIGHT TO DRIVE CONTACTOR	19DEC00	JCN

REV.	DESCRIPTION	DATE	BY

The Dishwashing Machine Specialists

UC-3T NUCCW
STEAM/ELECTRIC

B 701512 REV. **C**

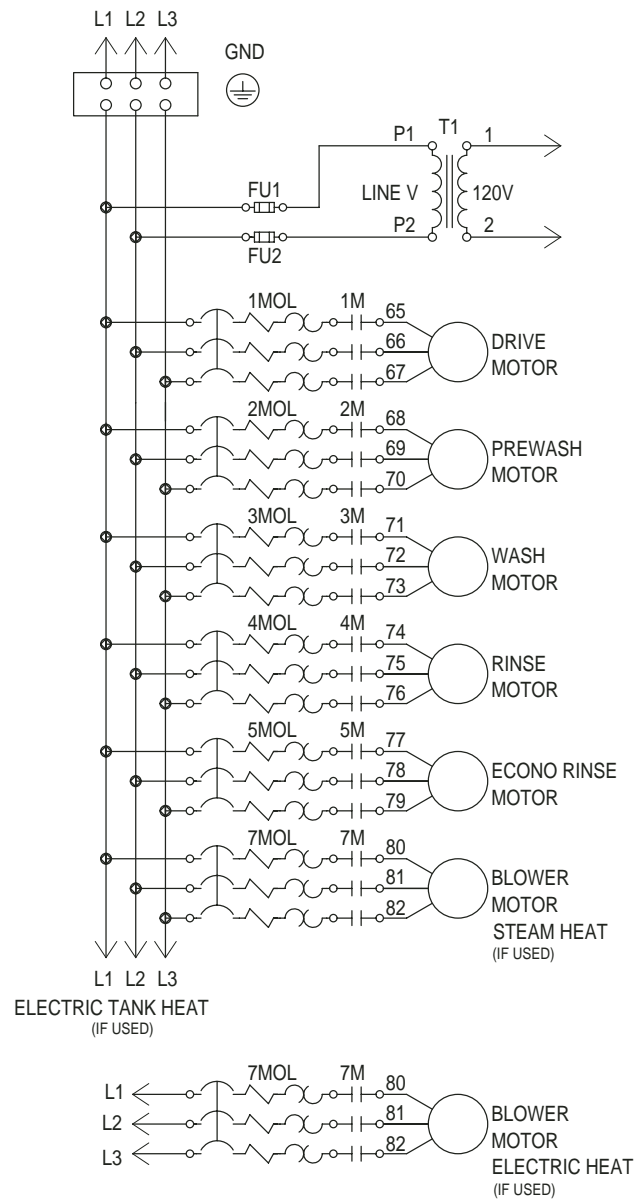
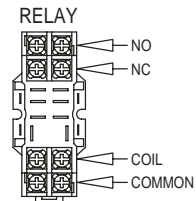
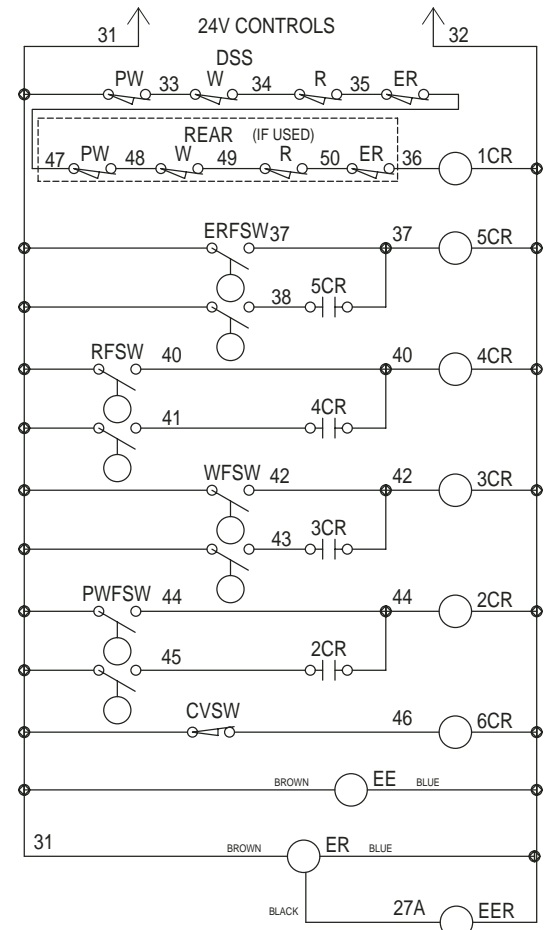
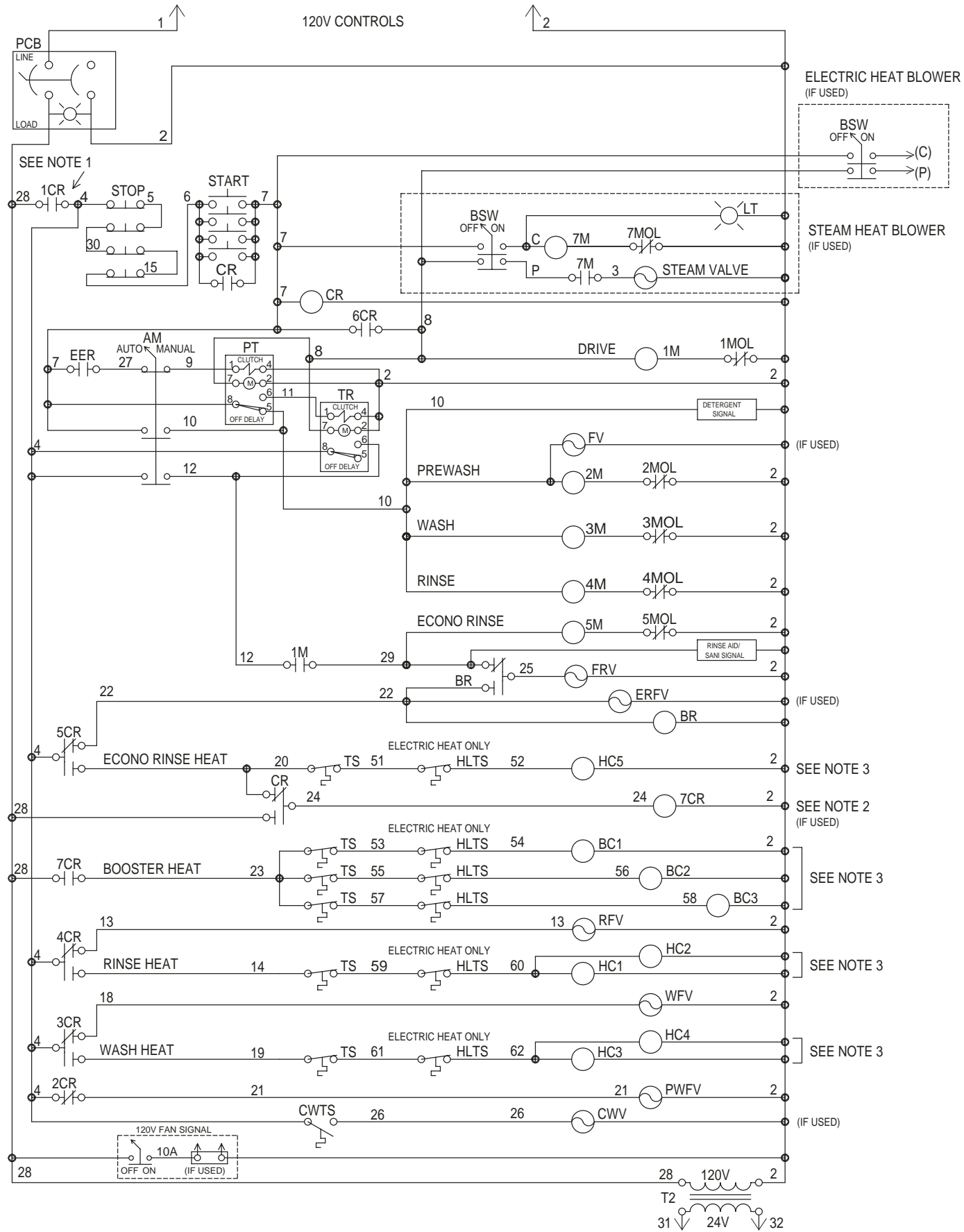

DIAGRAM STATE
POWER OFF
DOORS CLOSED
TANKS EMPTY



- NOTES:
- IF DSS (1CR) IS NOT USED, CONNECT WIRES #4 TO #28
 - 7CR RELAY AND CR CONTACT ONLY USED WITH BOOSTER
 - WHEN STEAM HEAT IS USED- HC1, HC3, ,HC5, BC1 ARE STEAM VALVES, HC2, HC4, BC2, BC3 ARE NOT USED
WHEN ELECTRIC HEAT IS USED- HC1 THRU 5, BC1 THRU 3 ARE ELECTRIC CONTACTORS



* COMPONENT LOCATED IN MAIN CONTROL CABINET			
1CR *	DOOR SAFETY HOLD IN RELAY	DSS	DOOR SAFETY SWITCH
2CR *	PREWASH FILL SWITCH RELAY	EE	ELECTRIC EYE EMITTER
3CR *	WASH FILL SWITCH RELAY	EER *	ELECTRIC EYE RELAY
4CR *	RINSE FILL SWITCH RELAY	ER	ELECTRIC EYE RECEIVER
5CR *	ECONO RINSE FILL SWITCH RELAY	ERFSW	ECONO RINSE TANK FLOAT SWITCH
6CR *	CONVEYOR SWITCH RELAY	ERFV	ECONO RINSE TANK FILL VALVE
7CR *	BOOSTER HEAT HOLD IN RELAY	FU1 *	FUSE-PRIMARY SIDE OF TRANSFORMER
1M *	DRIVE MOTOR CONTACTOR	FU2 *	FUSE-PRIMARY SIDE OF TRANSFORMER
1MOL *	DRIVE MOTOR OVERLOAD	FRV	FINAL RINSE AND ECONO RINSE TANK FILL VALVE
2M *	PREWASH MOTOR CONTACTOR	FV	FLUSHING VALVE
2MOL *	PREWASH MOTOR OVERLOAD	GND *	GROUND
3M *	WASH MOTOR CONTACTOR	HC1 *	RINSE TANK ELECTRIC HEAT CONTACTOR OR STEAM VALVE
3MOL *	WASH MOTOR OVERLOAD	HC2 *	RINSE TANK CONTACTOR-ELECTRIC HEAT ONLY
4M *	RINSE MOTOR CONTACTOR	HC3 *	WASH TANK ELECTRIC HEAT CONTACTOR OR STEAM VALVE
4MOL *	RINSE MOTOR OVERLOAD	HC4 *	WASH TANK CONTACTOR-ELECTRIC HEAT ONLY
5M *	ECONO RINSE MOTOR CONTACTOR	HC5 *	ECONO RINSE TANK ELECTRIC HEAT CONTACTOR OR STEAM VALVE
5MOL *	ECONO RINSE MOTOR OVERLOAD	HLTS	HIGH LIMIT THERMOSTAT-ELECTRIC HEAT ONLY
7M *	STEAM HEAT BLOWER MOTOR CONTACTOR	PCB *	POWER SWITCH/CIRCUIT BREAKER/POWER ON LIGHT
7MOL *	STEAM HEAT BLOWER MOTOR OVERLOAD	PT *	PUMP TIMER
AM *	AUTO-MANUAL MODE SWITCH (ELECTRIC EYETIMER BYPASS)	PWFV	PREWASH TANK FILL VALVE
BC1	BOOSTER ELECTRIC HEAT CONTACTORS OR STEAM VALVE	PWFSW	PREWASH TANK FLOAT SWITCH
BC2	BOOSTER TANK CONTACTORS-ELECTRIC HEAT ONLY	RFV	RINSE TANK FILL VALVE
BC3	BOOSTER TANK CONTACTORS-ELECTRIC HEAT ONLY	RFSW	RINSE TANK FLOAT SWITCH
BR *	RINSE AID SIGNAL RELAY	T1 *	CONTROL TRANSFORMER - LINE V:120V
BSW *	BLOWER SWITCH	T2 *	CONTROL TRANSFORMER - 120V:24V
CR *	HOLD-IN RELAY	TR *	FINAL RINSE TIMER
CVSW	CONVEYOR SWITCH	TS	THERMOSTAT
CWTS	COLD WATER THERMOSTAT	WFSW	WASH TANK FLOAT SWITCH
CWV	COLD WATER VALVE	WV	WASH TANK FILL VALVE

CUSTOMER TO SUPPLY RATED VOLTAGE/PHASE/Hz, AS SPECIFIED PER ORDER, TO DISCONNECT SWITCH. ALL POWER SUPPLIED TO EACH CONNECTION POINT MUST COMPLY WITH ALL LOCAL ELECTRIC CODES.			
DR. BY	J. NEWTON	SCALE	NONE
DATE	4DEC97	SHEET	1 OF 1

REV.	DESCRIPTION	DATE	BY
A	CHANGED DESCRIPTION OF EER IN TABLE	17OCT00	JCN
B	ADDED VENT FAN CKT	7AUG01	JCN

REV.	DESCRIPTION	DATE	BY

UC-4T-WS NUCCW
STEAM/ELECTRIC - STANDARD

B 701559 REV. **B**

The Dishwashing Machine Specialists