

# Champion<sup>®</sup>

The Dishwashing Machine Specialists

---

## Technical Manual

---

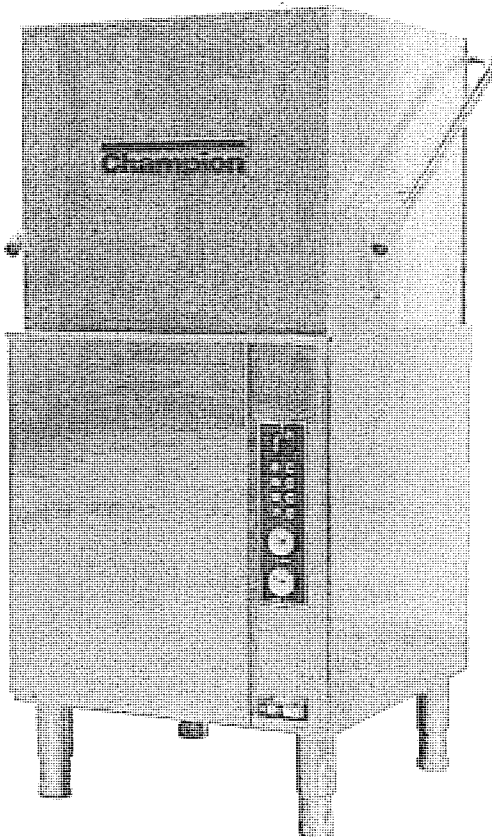

**Hood Type  
Dishwasher**

**Model:**

**W-DH** High Temperature with Built-in Booster

**Machine Serial No.**

**March, 2003**

**Manual P/N 113365 Rev B**

---

P.O. Box 4149  
Winston-Salem, North Carolina 27115-414  
336/661-1556 Fax: 336/661-1660

2674 N. Service Road  
Jordan Station, Ontario, Canada L0R 1S0  
905/562-4195 Fax: 905/562-4618

Complete the information below so it will be available for quick reference.

Model Number \_\_\_\_\_ Serial Number \_\_\_\_\_

Voltage and Phase \_\_\_\_\_

Champion Service Agency \_\_\_\_\_ Phone \_\_\_\_\_

Champion Parts Source \_\_\_\_\_ Phone \_\_\_\_\_

**Champion Service:**

Champion (USA)

Phone: 1 (336) 661-1556

1 (800) 858-4477

Fax: 1 (336) 661-1660

E-mail [service@championindustries.com](mailto:service@championindustries.com)

We strongly recommend that you Fax or e-mail your orders.

**NOTE:** When calling to order parts, be sure to have the model number, serial number, voltage and phase of your machine.

Machine Data Plate with model & serial number located on the front of the lower panel.

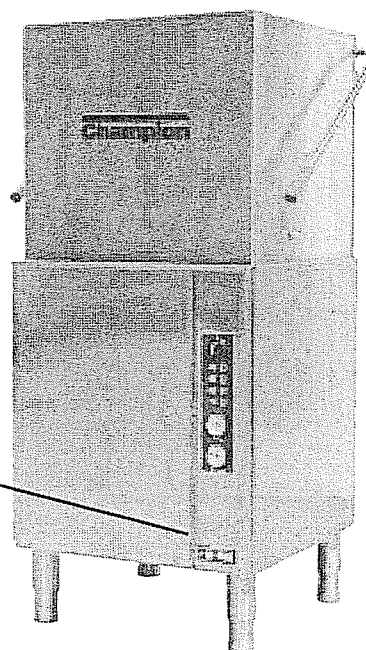

## Revision History

<b>Revision Date</b>	<b>Revised Pages</b>	<b>Serial Number Effectivity</b>	<b>Comments</b>
09/01/01	—		First issue of manual and replacement parts
06/10/02	3		Inserted electrical wiring diagrams.
3/28/03	16, 17		Inserted revised drawing and parts list.

# REVISION RECORD

---

**CONTENTS**

	Page
REVISION HISTORY .....	i
GENERAL .....	1
INSTALLATION .....	2
Unpacking .....	2
Electrical Connections .....	2
Plumbing Connections .....	4
Ventilation Connections .....	4
Chemical Connections .....	5
Completing Installation .....	5
OPERATION .....	6
MAINTENANCE .....	7
Daily Cleaning .....	7
Maintenance .....	7
TROUBLESHOOTING .....	9
REPLACEMENT PARTS .....	11
ELECTRICAL SCHEMATICS .....	23

**LIST OF FIGURES**

Figure 1— Front Panel .....	2
Figure 2— Wiring Connection .....	3
Figure 2— Wash Tank Assembly .....	12
Figure 3— Wash and Rinse Assemblies .....	14
Figure 4— Rinse Booster Assembly and Rinse System .....	16
Figure 5— Control Cabinet .....	18
Figure 6— Control Panel .....	20

---

**THIS PAGE  
INTENTIONALLY  
LEFT BLANK**

# GENERAL SPECIFICATIONS

## About this manual

All information, illustrations and specifications contained in this manual are based upon the latest product information available at the time of publication. Champion constantly improves its products and reserves the right to make changes at any time or to change specifications or design without notice and without incurring any obligation.

## Organization of Manual

This manual is divided into seven parts:

- General Specifications
- Installation
- Daily Operation
- Cleaning and Maintenance
- Troubleshooting
- Replacement Parts, contains parts diagrams and parts list.
- Electrical Schematics



### NOTE:

*Unless noted otherwise, dimensions, capacities, temperatures, etc., given in this manual are U.S. Customary Measures and the Metric Equivalent of the U.S. Customary measures.*

## Model

The W-DH model is a high temperature (180F/82°C rinse) sanitizing model with booster.

## Standard Equipment

- Automatic operation
- Built-in electric booster heater
- Field convertible to corner model
- Electric tank heat
- Extended wash/de-lime switch
- Low-water tank heat protection
- 1-hp drip-proof pump motor
- Splash-proof control console
- Door safety switch
- Common utility connections
- Detergent/chemical connection provisions
- Balanced door lift system
- Stainless steel front and side panels
- Interchangeable upper and lower spray arms
- International symbols on controls

# INSTALLATION

## Unpack the dishwasher



**CAUTION:**

*Care should be taken when lifting the machine to prevent damage.*



**NOTE:**

The installation of your machine must meet all applicable health and safety codes.

1. Immediately after unpacking the machine, inspect for any shipping damage.

If damage is found, save the packing material and contact the carrier immediately.

2. Remove the dishwasher from the skid. Move the machine to its permanent location.
3. Machine must be placed on a sound self-draining floor.
4. Level the machine (if required) by placing a level on the top of the machine and adjusting the feet. Level the machine from front-back and side to side.
5. Refer to Fig 1. Remove (2) screws that hold the front panel. Remove the front panel in preparation for service connections.

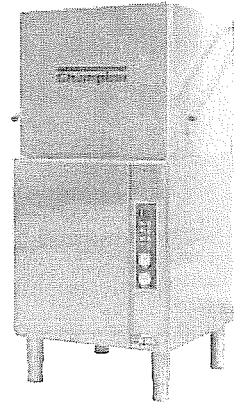

**Figure 1**  
Remove Front Panel

## Electrical Connections



**WARNING:**

*Electrical grounding connections must comply with all applicable Electrical Codes.*



**WARNING:**

*When working on the dishwasher, disconnect the electric service and place a tag at the disconnect switch to indicate work is being done on that circuit.*

1. A qualified electrician must compare the electrical power supply with the machine electrical specifications before connecting to the incoming service through a fused disconnect switch.
2. Recommended electrical supply is three phase, permanently wired via wall switch mounted adjacent to machine. Machine may also be installed on 25A single phase (15A single phase with reduced rinse heating). Easy on site conversion of standard machine for any of these requirements.
3. A knock out is provided at the lower right rear corner (as viewed from the front) for electrical service connection. A fused disconnect switch or circuit breaker (supplied by others) is required to protect the power supply circuit.
4. Remove (2) lower screws from the front panel of the machine to expose the electrical controls.
5. Three phase or single phase incoming wire connections are made at the bottom of the machine's main terminal block. The main terminal block is located on the side of the front right post of the dishwasher.



### SINGLE PHASE CONNECTION

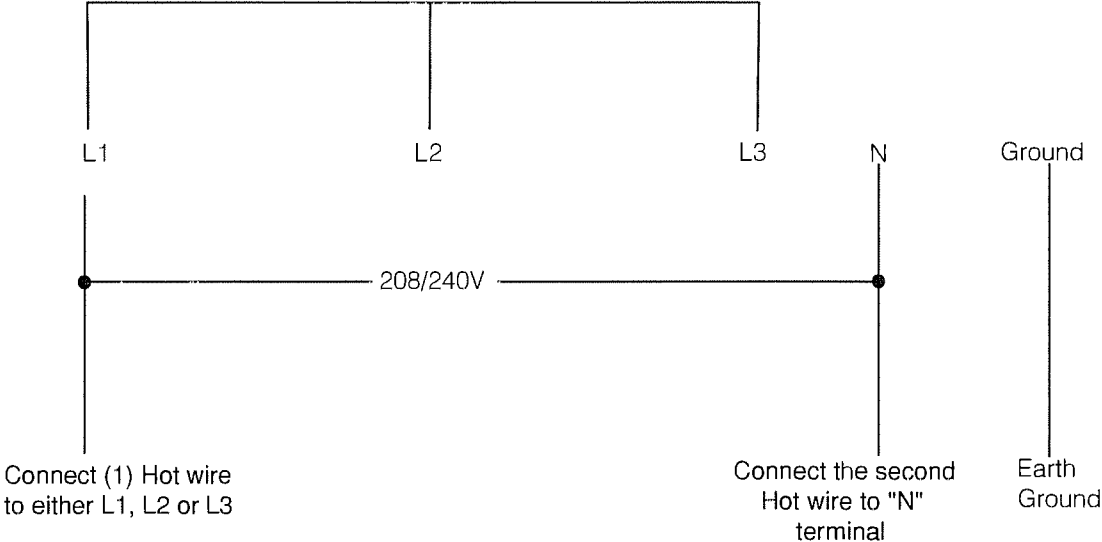

### THREE PHASE CONNECTION

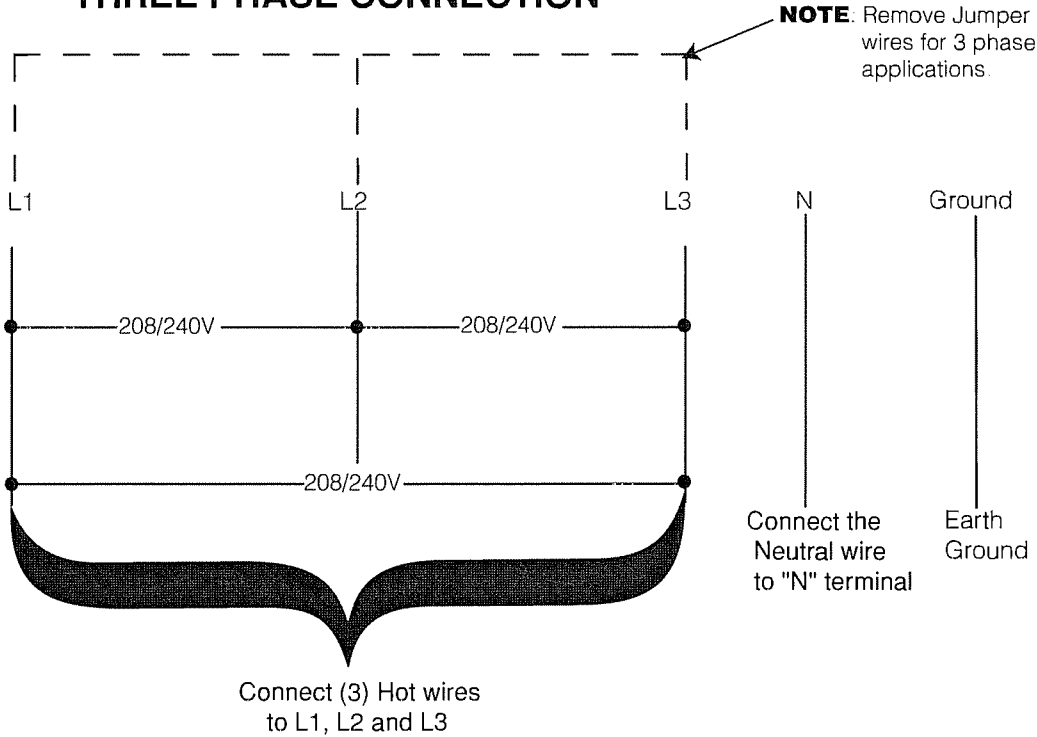

Figure 2  
Wiring Connections

## INSTALLATION (CONT.)

### Plumbing Connections



**NOTE:**

*Plumbing connections must comply with all applicable sanitary and plumbing codes.*

### Water Connections

1. All W-DH dishwashers require a single, hot water supply.
2. The hot water connection to the dishwasher is 1/2" BSP male.
3. The connection is made from underneath the dishwasher.
4. The recommended minimum water temperature is 140F/60°C.
5. A manual shut-off valve for water (supplied by others) should be installed in the supply line to allow for servicing of the machine. The shut-off valve should be the same size or larger than the supply line.
6. Install a pressure reducing valve (PRV) in the water supply line if flow pressure exceeds 20-22 PSI/138-151.8kPa.

### Drain Connections

1. The dishwasher is a gravity drain machine equipped with 1-1/2" O.D. hose connection point.
2. The maximum drain flow rate is 15 gallons/min-56.8 liters/min.
3. Drain height for the dishwasher must not exceed 11" (280mm) above the floor level.
4. The drain connection is made to the dishwasher from behind the machine or through an access hole in the base of the machine.

### Ventilation



**NOTE:**

*Ventilation must comply with local sanitary and plumbing codes.*



**CAUTION:**

Exhaust air should not be vented into a wall, ceiling, or concealed space of a building. Condensation can cause damage.

## INSTALLATION (CONT.)

### Chemical Connections

#### NOTE:

*Consult a qualified chemical supplier for your chemical needs.*

1. A chemical signal terminal block is supplied for chemical dispensing equipment.
2. The terminal block is located below the control panel fuse block.
3. The detergent signal is limited to a maximum load of 1 Amp. Signal voltage is 115VAC.
4. The Rinse aid signal is limited to a maximum load of 1 Amp. Signal voltage is 115VAC.
5. The feeder units must have separate neutrals for detergent and rinse aid connections.
6. A 1/2" detergent injection point is provided at the rear and left side of the dishwasher.
7. Detergent may be added manually, put in three tablespoons of powdered domestic detergent into the wash tank after the machine has been filled, then add another tablespoon full after every fourth or fifth cycle. This is not recommended except in a temporary situation, ex: dispensing equipment is down, out of chemical and awaiting supplier, etc.
8. Rinse aid injectors can be purchased separately. There is a 1/4" NPT rinse aid injection point provided in the final rinse manifold. Use a liquid rinse aid. Contact your local chemical supplier about product type for factors such as water hardness etc.

### Peristaltic Detergent Pump

To prime the peristaltic pump:

1. Insert pump inlet hose into the detergent container.
2. Close machine door and switch machine on.
3. Allow wash tank to fill up then press detergent pump prime switch to prime inlet and outlet hose.
4. Stop priming when detergent reaches machine.

Machine will not fill unless **READY** light is on and door is shut. Turn power off before opening door as machine will cycle again when door is closed. Pump operates during the wash cycle and is set to run for approximately 10 seconds. Use yellow adjusting tool, supplied with the instructions, to adjust cam 6 to vary this time. Increase cam gap (away from 0 mark) to increase pumping time.

# INITIAL START-UP

## Complete the installation

After the plumbing and electrical connections are made, follow the steps below to complete the installation of your dishwasher.

1. Remove the protective covering from the exterior of the machine.
2. Remove any foreign material from the inside of the machine.
3. Make sure dishwasher power is off.
4. Turn the main water supply on.
5. Turn main power on at the main power service disconnect switch.
6. Install the scrap screens.
7. Make sure that the overflow seats securely in the tank bottom.
8. Make sure doors are fully closed.
9. The control panel is located on the lower right side of machine. Select any cycle (1, 2, 3 minutes).
10. The **ON** light will glow red and the machine will fill automatically.
11. When machine is full the tank heater and booster heater will begin to heat the water in the dishwasher. Wait approximately 10 minutes for the wash tank to reach operating temperature. The temperature should be a minimum of 140F/60°C. The machine is ready for use when the **READY** light (tick symbol) glows amber.

# OPERATION

## Operation and Use

1. Before washing make sure that:
  - wall mounted on/off switch is switched on;
  - water supply is open and water pressure is present;
  - pump suction filters are installed in proper location;
  - overflow tube is inserted in drain;
  - rotating spray arms move freely;
  - rinse and detergent containers are full;
2. Select required cycle. Try cycle 3 initially and switch to faster cycles only if necessary.
3. Scrap and preflush all items to be washed. Load items into the rack. Do not overload the rack. Wash only one layer of silverware in a rack.
4. Open the door and insert the rack into machine. Close door.
5. Machine starts automatically. **CYCLE** light glows green.
6. Remove rack when the **CYCLE** light goes out.



### NOTE:

*Machine will not operate unless the **READY** light is on. Wash temperature light (thermometer symbol) glows amber when wash temperature has been reached. After removing racks from machine, **DO NOT** shut door as machine will start up again.*

---

## DAILY CLEANING

1. Turn dishwasher and wall switch OFF.
2. Remove the overflow to drain wash tank.
3. Remove scrap screens and wash pump inlet screen. Rinse thoroughly to make sure that they are clean. Do not bang or beat them on the side of sink or other hard objects as this will eventually cause them to break or bend thus causing them to fit or work properly.
4. Reinstall the overflow, pump screen, and the scrap screens.

Frequently check and clean the nozzles. Blocked nozzles will prevent the machine from cleaning properly. To clean the wash/rinse arms:

1. Undo the thumbscrew that holds the arms in place. Do not remove the retaining plate.
2. Twist and remove the end nozzle then withdraw the end cap.
3. Flush arms with water, use a toothpick or paperclip (if necessary) to clear the nozzles.
4. Do not beat the arms on anything to clean nozzles.
5. Replace end cap and end nozzle.
6. Replace arms back into position in machine.

To flush out dishwasher if needed:

1. Leave the overflow out of machine.
2. Close the door.
3. Turn power **ON** at the dishwasher.
4. Leave on machine on for about 20 seconds. **DO NOT** leave machine unattended during this process.
5. Shut power OFF to dishwasher.

# MAINTENANCE

Before carrying out the cleaning and the maintenance operations, turn off the main disconnect switch for the equipment.

Do not use corrosive products such as sodium hypochlorite (bleach), acids, steel wool or steel brushes to clean the inside and the outside of machine.

The presence of calcium and magnesium salt in water can compromise machine performance. Asked a qualified chemical person to remove the deposits periodically.

Stainless steel surfaces should be cleaned well in order to avoid some oxidation risks, or chemical reactions.

### **Optimal Results:**

Poor wash results can be noted when residue remains on the dishware. To guard against poor results, make sure of the following:

- Wash nozzles are clean.
- Rinse nozzles are clean and there is sufficient water supply pressure 20-22 PSI/138-151.8kPa.
- Water temperature is a minimum of 140F/60°C.
- Detergent is in the chemical container
- Pump suction filters are clean.
- Racks are suitable for the dishes and cutlery that are to be washed.

## TROUBLESHOOTING

In order to find the cause of a breakdown or abnormal operating condition in your dishwasher please ensure that:

1. All switches are ON
2. Drain and overflow tube are in place and seated
3. Wash pipe and rinse nozzles are clean
4. Scrap screens and pump inlet screen are properly positioned
5. Spray arms are in their proper positions
6. Thermostat(s) are at their correct setting
7. Detergent, and rinse additive dispensers are adequately filled
8. Doors are fully closed.

If a problem still exists, use the following table for troubleshooting

CONDITION	CAUSE	SOLUTION
Cycle will not start	Door not closed .....	Make sure doors are fully closed
	Door safety switch faulty .....	Contact your service agency
	Start switch faulty .....	Contact your service agency
	Main switch off .....	Check disconnect
	Overload protector tripped .....	Reset overload in control box
	Not up to temperature .....	Give machine time to initially reach temperature
Low or no water	Main water supply is turned off .....	Turn on house water supply
	Drain/overflow tube is not in place and seated .....	Place and seat drain tube
	Machine doors not fully closed .....	Close doors securely
	Faulty fill valve .....	Contact your service agency
	Stuck or defective float .....	Check floats and clean
Continuous water filling	Stuck or defective float .....	Check floats and clean
	Fill valve will not close .....	Clean or replace
	Drain tube not in place .....	Look for drain tube in tank
	Pressure switch faulty .....	Replace pressure switch
Any motor not running	Overload protector tripped .....	Reset overload in control box
	Defective motor .....	Contact your service agency
Wash tank water temperature is low when in use	Incoming water temperature at machine too low .....	Raise temperature to 140°F/60°C
	Defective thermometer .....	Check or replace
	Defective thermostat .....	Check for proper setting or replace
	Defective heater element .....	Check or replace
	Defective solenoid valve .....	Check or replace
Arms not rotating	Rinse nozzles not clean .....	Clean
	Bearings worn .....	Replace
	Water supply pressure low .....	Check incoming water pressure

# REPLACEMENT PARTS

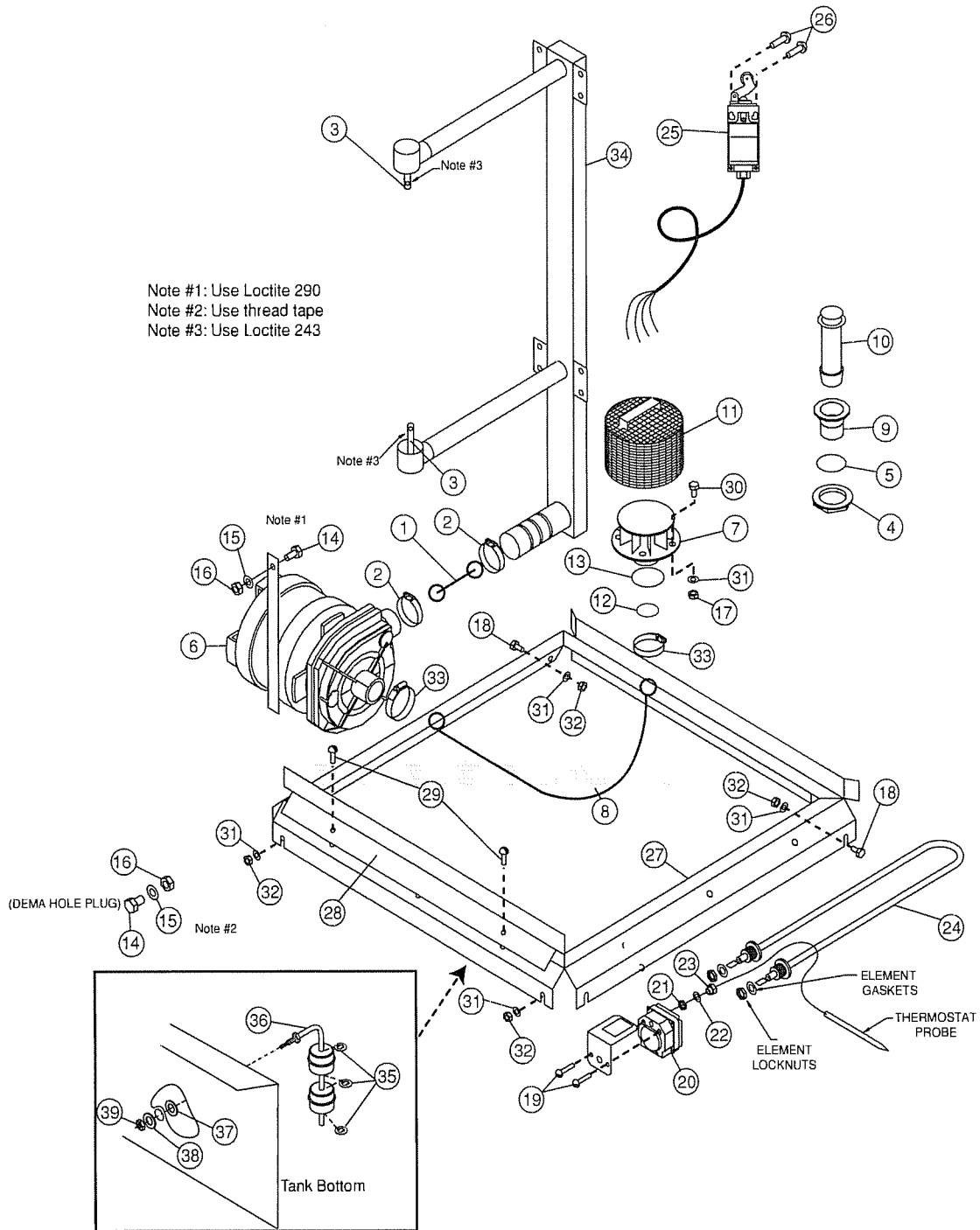

Figure 3  
Wash Tank Assy



## WASH TANK ASSEMBLY

Fig.3 Item No.	Part No.	Part Description	Qty.
1	32590001	Hose Outlet .....	1
2	ASS24	Hose Clamp .....	2
3	40030000	Spindle .....	2
4	6037	Backnut 126*40mm .....	1
5	1896	Drain Waste Gasket .....	1
6	3904	Wash Pump Assy (Includes the items listed below but not shown).....	1
--	39042	Impellor (Not Shown) .....	1
--	0802	Pump Seal (Not Shown).....	1
--	38886	Pump Gasket (Not Shown).....	1
--	38884	Pump Volute (Not Shown).....	1
7	C160603	Pump Inlet Flange .....	1
8	24.38210	Hose Inlet .....	1
9	C16301	Drain Outlet .....	1
10	C180704	Overflow Pipe .....	1
11	1238	Wash Inlet Filter .....	1
12	ARP229	Oring .....	1
13	ARP241	Oring .....	1
14	8835	Set Screw 5/6" x 1/2" .....	2
15	8568	Washer Spring 5/16" .....	2
16	8058	Nut 5/16" .....	2
17	8106	Nut Hex M6 .....	4
18	88461	Bolt Hex Head M6 x 12 .....	2
19	8800	Screw Pan Head M4 x 6 .....	2
20	30201	Thermostat .....	1
21	3032	Gland Nut .....	1
22	3033	Gasket Gland .....	1
23	3031	Gland Bulkhead .....	1
24	30071	Element Wash 1.8KW .....	1
25	60030092	Door Switch Assy .....	1
26	88021	Screw Pan Head M4 x 30 .....	2
27	1557	Rack Guide .....	1
28	1560	Rack Guide Bracket .....	1
29	60080017	Bolt Truss Head M5 x 12 .....	2
30	60080015	Bolt Hex M6 x 16 .....	4
31	8566	Washer Spring 1/4" .....	8
32	8108	Nut Dome M6 .....	4
33	ASS36	Hose Clamp .....	2
34	32510012	Wash Manifold .....	1
35	111151	C-Clip Float Switch (per float ball) .....	2
36	110854	Dual Float Switch .....	1
37	110750	Gasket float switch .....	1
38	107589	Washer, lock 1/2" .....	1
39	104584	Nut, Plain (1-2-13) .....	1

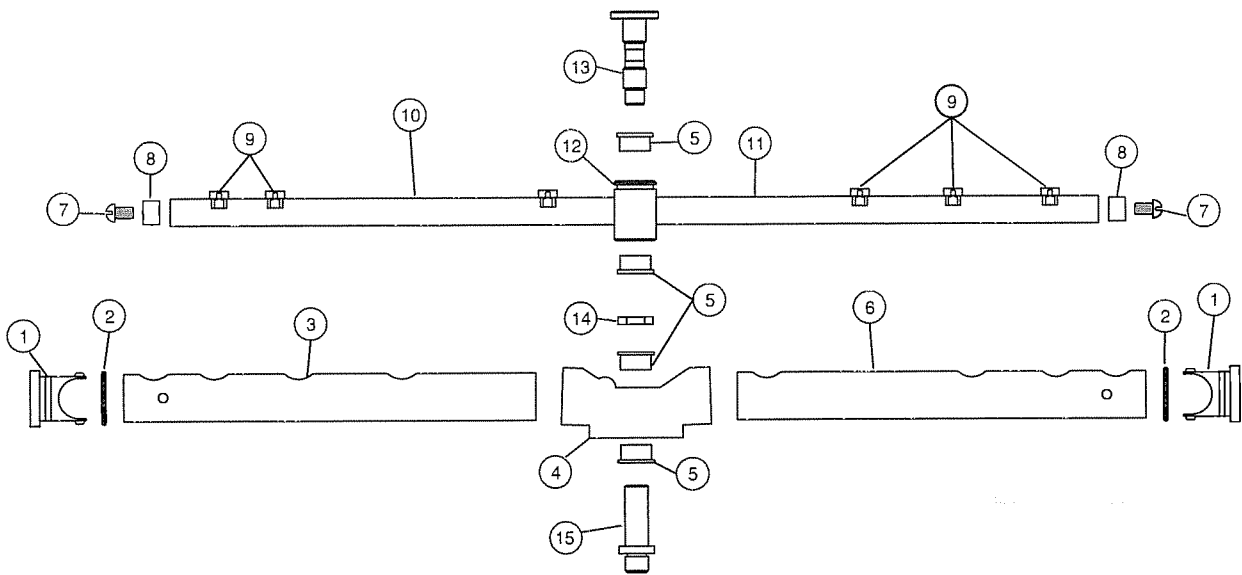

Figure 4  
Wash and Rinse Arm Assemblies

## WASH AND RINSE ARM ASSEMBLIES

Fig.4 Item No.	Part No.	Part Description	Qty.
1	40030037	Plug, Wash End .....	2
2	ARP018	O-ring, Wash Plug .....	2
3	32530020	Wash Arm .....	1
4	32590023	Wash Hub .....	1
5	C190624	Plastic Bushing .....	4
6	40030021	Wash Arm .....	1
7	60080017	Screw M5 x 12 Truss Head .....	2
8	40030010	Plug, Rinse Arm .....	2
9	60020001	Nozzle, Rinse .....	6
10	81530002	Rinse Arm .....	1
11	81530001	Rinse Arm .....	1
12	40030002	Rinse Arm Hub .....	1
13	40030073	Rinse Arm Spindle .....	1
14	40030074	Wash Spindle Nut .....	1
15	40030072	Wash Arm Spindle .....	1
16	32510014	Wash Arm Assembly (includes items 1-6) .....	A/R
17	81510013	Rinse Arm Assembly (include items 5, 7-12) .....	A/R

# REPLACEMENT PARTS

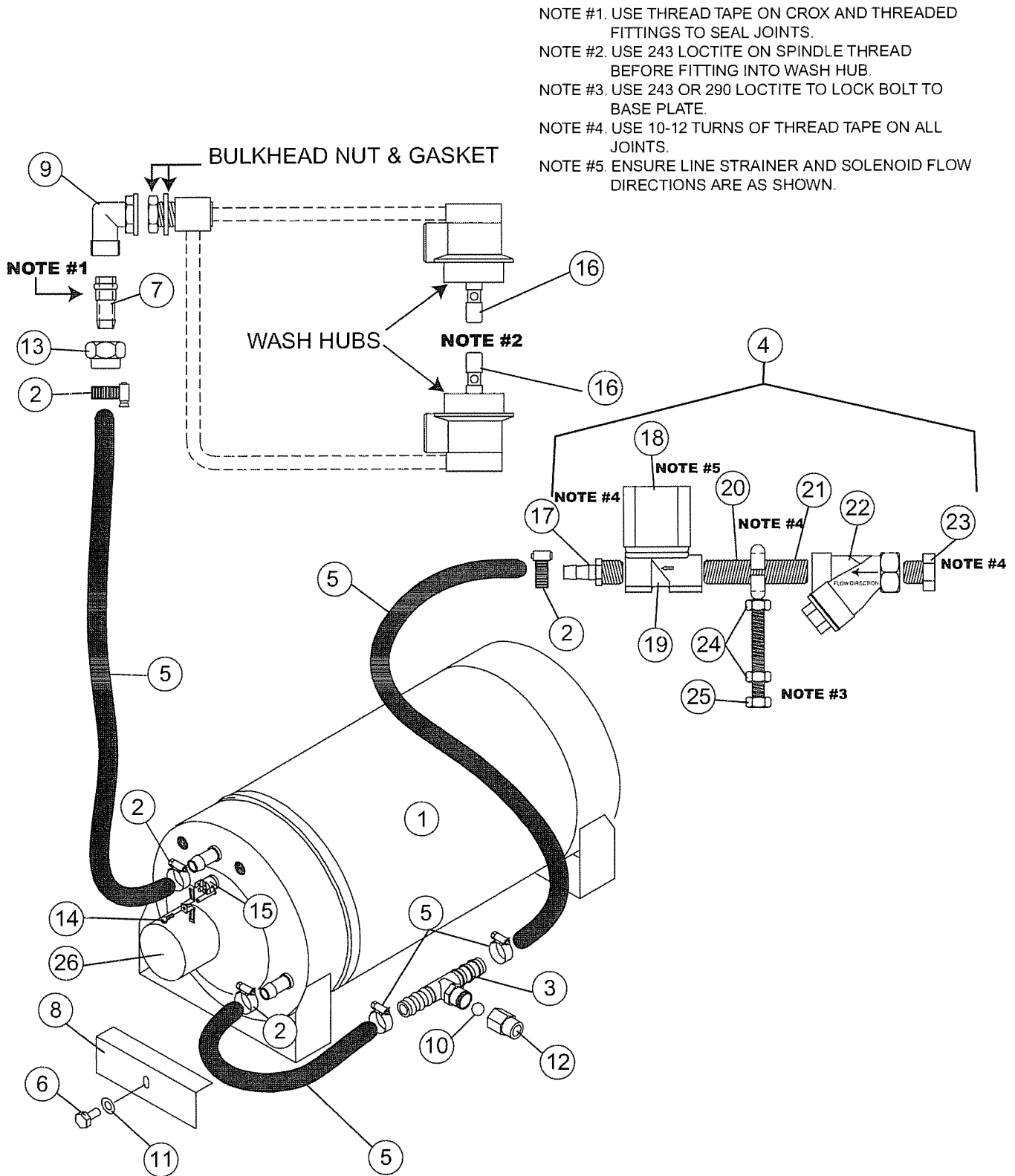

Figure 5  
Rinse Booster Assembly and Rinse System

RINSE BOOSTER ASSEMBLY  
AND RINSE SYSTEM

Fig.5 Item No.	Part No.	Part Description	Qty.
1	40010061	Rinse Booster Assy (Includes Item 26) .....	1
2	60090028	Hose Clamp .....	6
3	60060066	Tee 12MM x 3/8 BSP Branch .....	1
4	1672	Rinse Solenoid Assy (Includes Items 17-25) .....	1
5	60060073	Hose .....	15ft
6	88461	Bolt Hex SST M6 x 12 .....	1
7	40030048	Crox Tailpiece MCO 1/2". .....	1
8	40020061	Bracket Rinse tank Mounting .....	1
9	6083	Elbow Crox-Female 15MM Brass .....	1
10	60090060	Ball Polypropylene PB030 7/16" .....	1
11	8566	Washer Spring M6 .....	1
12	60060067	Socket 3/8 x 1/8 Nylon Reducing .....	1
13	6001	Nut Crox 15MM Brass .....	1
14	60080052	Bolt Pan Slot M3 x 6 .....	1
15	60030088	Thermostat .....	1
16	40030072	Wash Spindle .....	2
17	6153	Tailpiece 1/2 x 1/2 .....	1
18	3324	Coil, Solenoid 240V 10W LED .....	1
19	3321	Body, Solenoid EVSI10 .....	1
20	60060003	Nipple 1/2" x 2" Brass .....	1
21	6075	Musen Ring Saddle Clamp Brass 20MM .....	1
22	6950	Strainer Line 1/2" .....	1
23	6047	Nipple Hex 1/2" .....	1
24	60080009	Nut SST Hex M10 .....	2
25	60080024	MS Hex SST 304 M10 x 60 .....	1
26	3005	Element 5KW 208-240V (Includes Cap & Gasket) .....	1

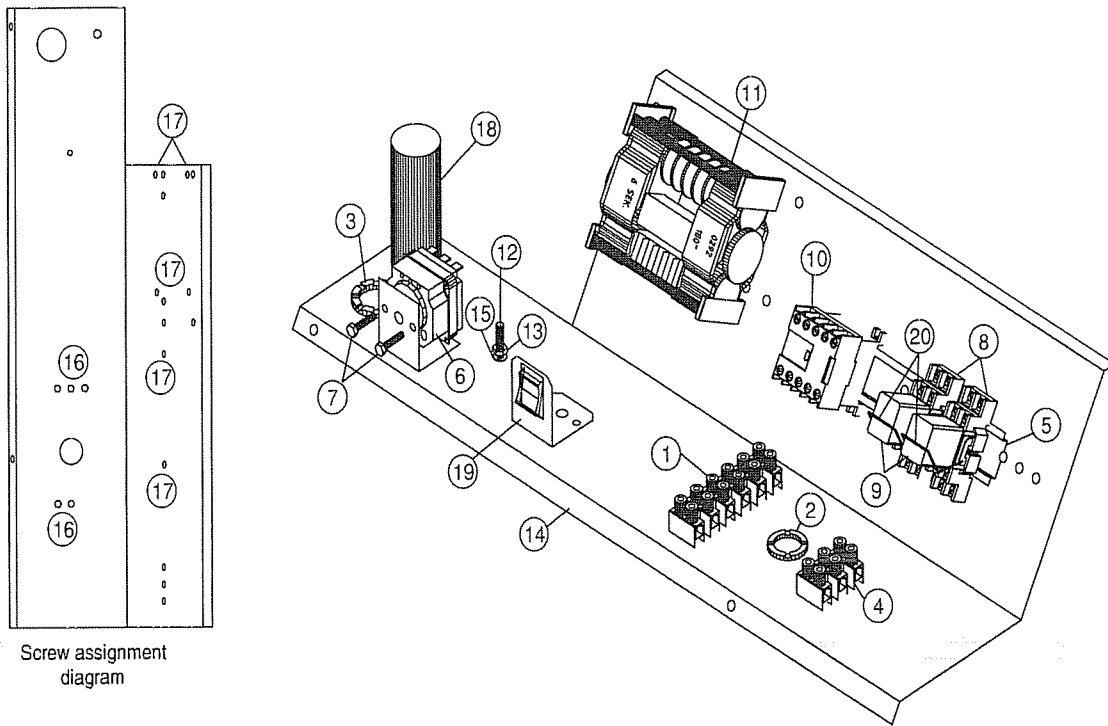

Figure6  
Control Cabinet

## CONTROL CABINET

Fig.6 Item No.	Part No.	Part Description	Qty.
1	32275	Terminal Strip 6 Way .....	1
2	60030089	Bushing Snap-In 25mm .....	1
3	60030090	Bushing Snap-In 30mm .....	1
4	3227	Terminal Strip 3 Way .....	1
5	3231	Din Rail .....	12"
6	3020	Thermostat .....	1
7	3028	Screw. ....	2
8	60030081	2 Pole Base .....	2
9	60030080	Relay 2 Pole 240V .....	2
10	60030083	Contactactor 240V .....	1
11	32823	Timer Triple Cycle 180sec .....	1
12	8816	Brass Stud 3/16 x 3/4 .....	1
13	8151	Nut Hex Brass 3/16 Pressed .....	1
14	16611	Wiring Tray Bracket Assy .....	1
15	8565	Washer Brass 3/16 .....	1
16	8802	Screw Pan M4 x 25 .....	4
17	8801	Screw Pan M4 x 12 .....	6
18	3894	Capacitor .....	1
19	60030097	On/Off Power Switch .....	1
20	60030082	Wire Clip Relay Base .....	2

---

**THIS PAGE  
INTENTIONALLY  
LEFT BLANK**



# **ELECTRICAL SCHEMATICS**

For a more detailed explanation of wiring connections, see page 3 Fig. 2 of Installation section in manual

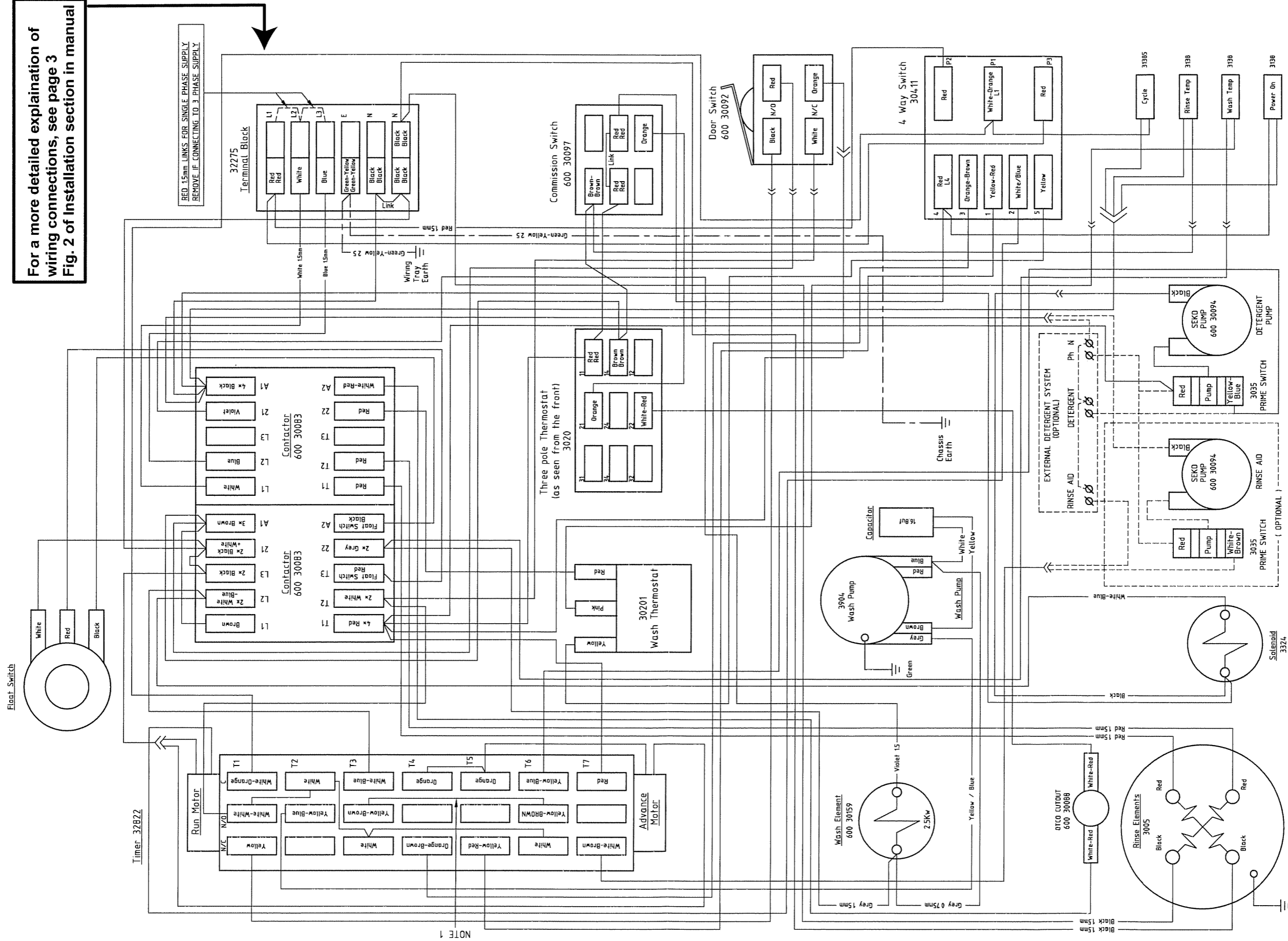

NOTE 1. REMOVE YELLOW-BROWN LINK ON TIMER TO DEACTIVATE DETERGENT PUMP DURING FILLING.

# Champion®

The Dishwashing Machine Specialists

W-DH ELECTRIC	DATE
080221	7/2602
REV C	

For a more detailed explanation of wiring connections, see page 3 Fig. 2 of installation section in manual

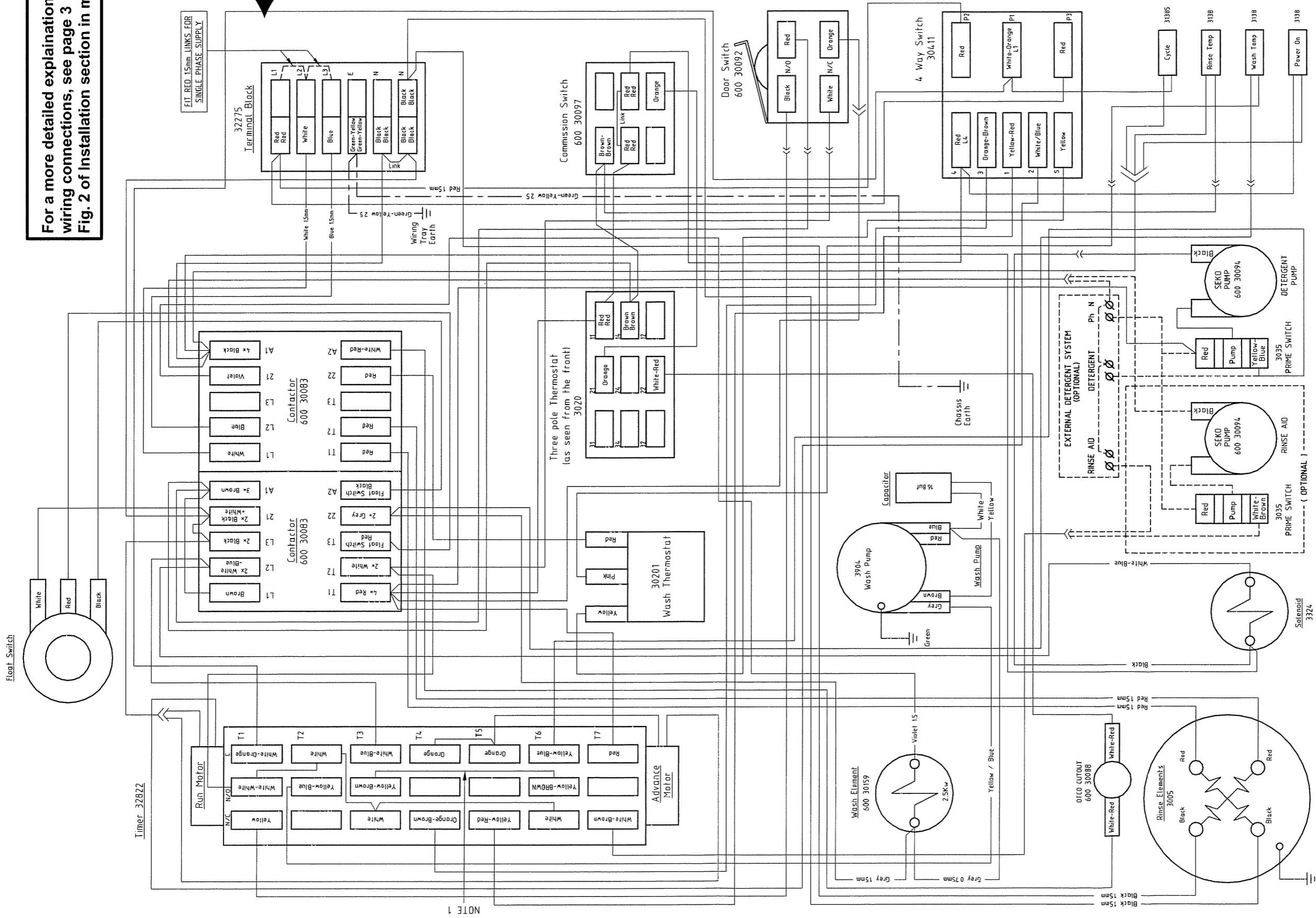

NOTE 1. REMOVE YELLOW-BROWN LINK ON TIMER TO DEACTIVATE DETERGENT PUMP DURING FILLING.

# Champion®

The Dishwashing Machine Specialists

080223	REV C	DATE	7/26/02
--------	-------	------	---------

For a more detailed explanation of wiring connections see page 3 Fig. 2 of Installation section of manual.

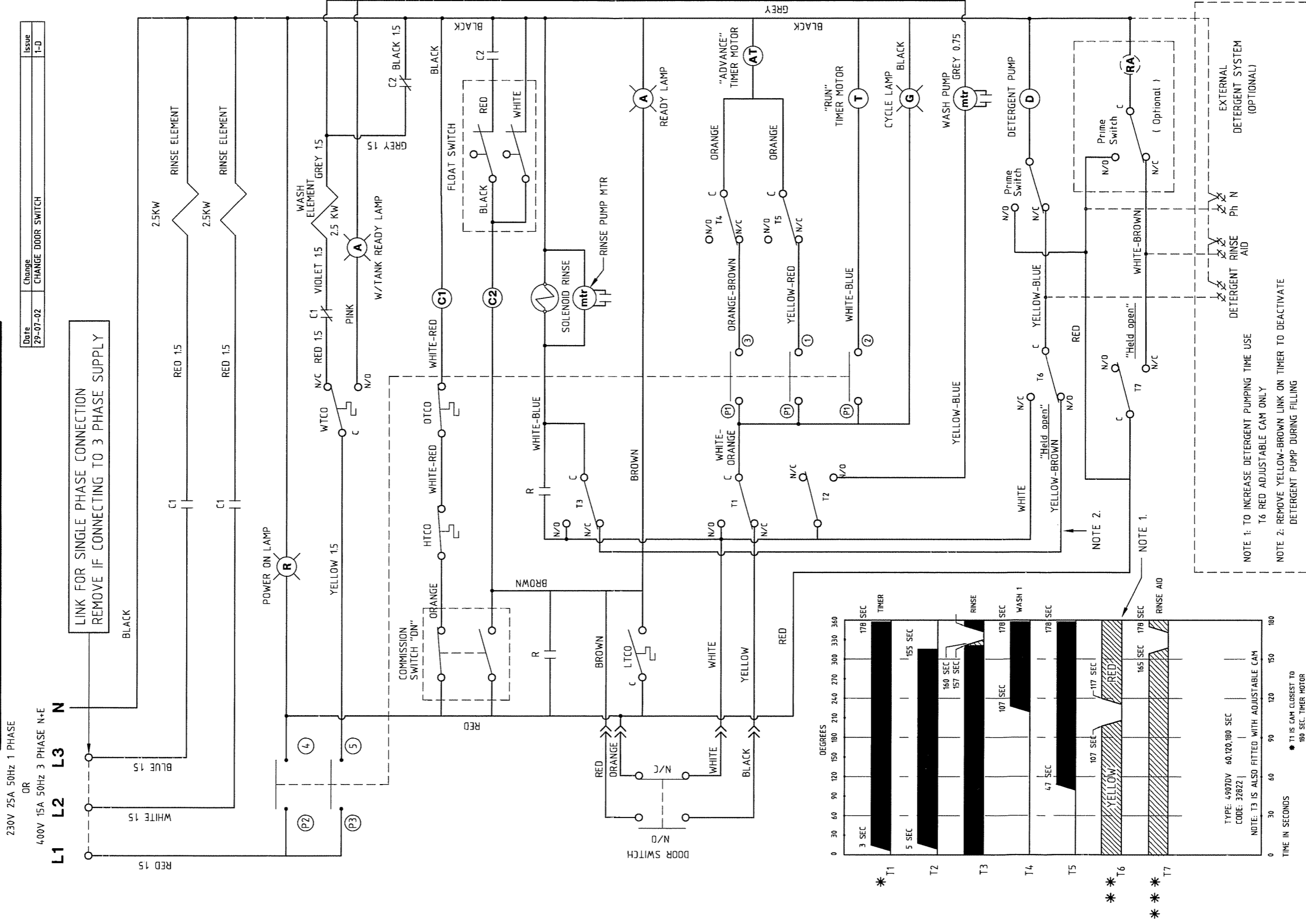

For a more detailed explanation of wiring connections see page 3 Fig. 2 of Installation section of manual.

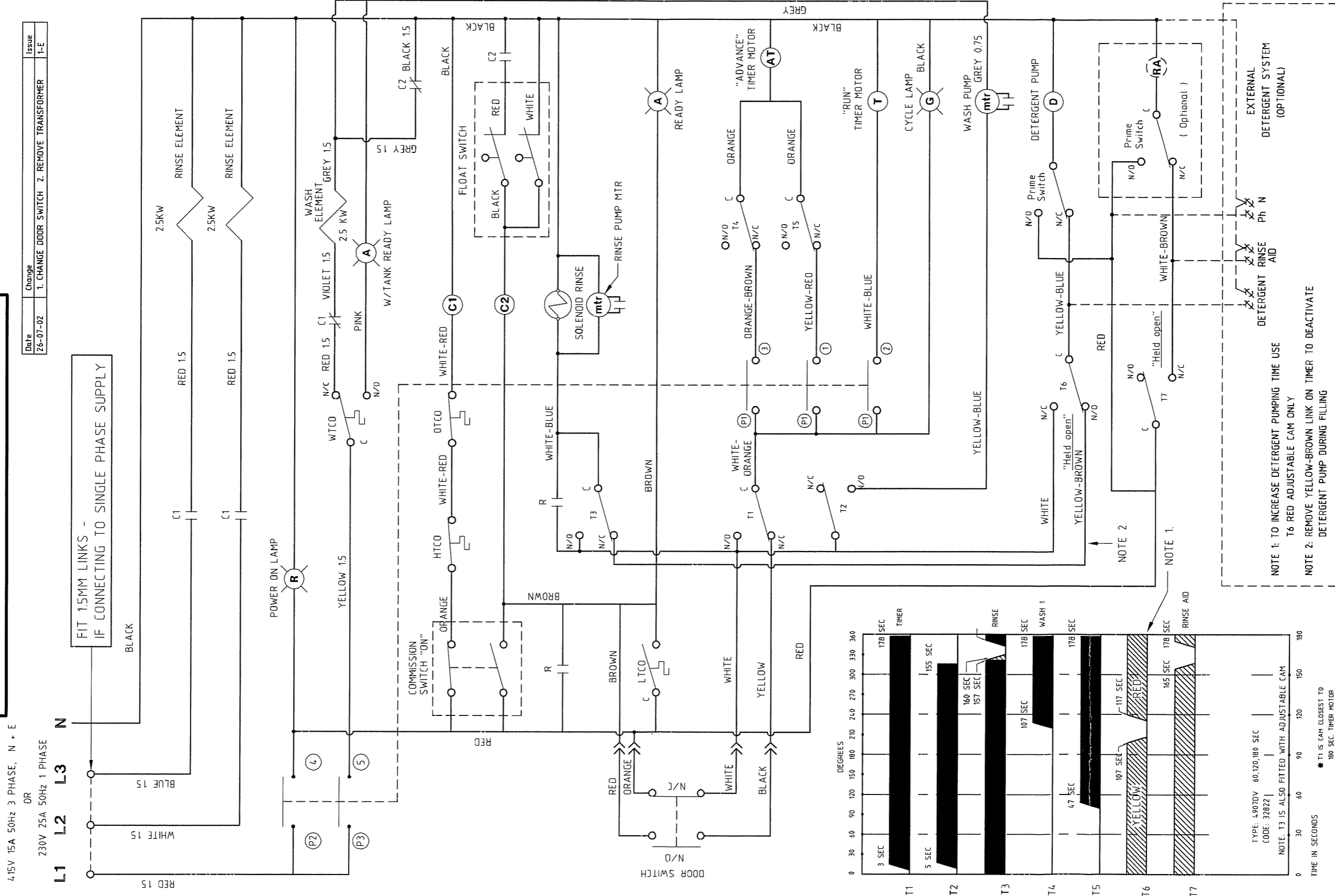

**Champion**<sup>®</sup>  
The Dishwashing Machine Specialists

W-DH ELECTRIC	DATE	7/29/02
REV E		
080134		