

Champion®



Installation/Operation Manual with Service Replacement Parts

Taskmaster

Model: PP-3
Power Wash Sink System

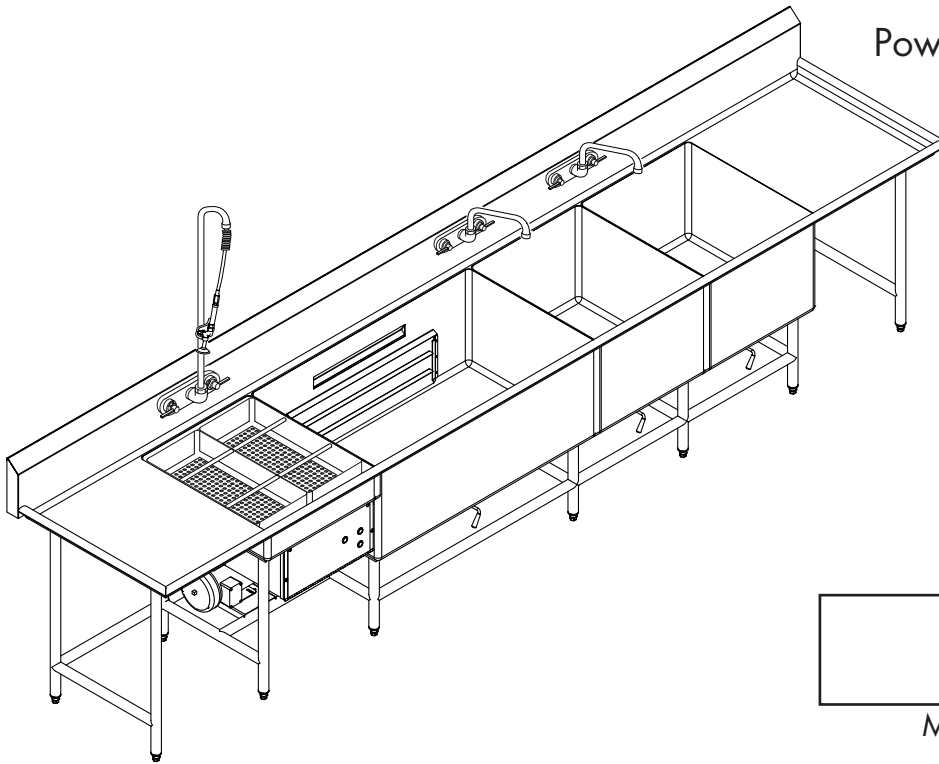

Machine Serial No.



Issue Date: 1.05.15

Manual P/N 115435 rev. A

For machines beginning with S/N PP314010010 and above

3765 Champion Boulevard
Winston-Salem, NC 27105
336/661-1556 Fax: 336/661-1660
Toll-free: 800/ 858-4477

2674 N. Service Road, Jordan Station
Ontario, Canada L0R 1S0
905/562-4195 Fax: 905/562-4618
Toll-free: 800/ 263-5798

Printed in the USA



For future reference, record your dishwasher information in the box below.

Model Number _____	Serial Number _____
Voltage _____ Hertz _____	Phase _____
Service Agent _____	Tel: _____
Parts Distributor _____	Tel: _____

National Service Department

In Canada:

Toll-free: 800/ 263-5798

Tel: 905/ 562-4195

Fax: 905/ 562-4618

email: service@moyerdiebellimited.com

In the USA:

Toll-free: 800/ 858-4477

Tel: 336/ 661-1556

Fax: 336/ 661-1660

email: service@championindustries.com

ATTENTION:

The model no., serial no., voltage, Hz and phase are needed to identify your machine and to answer questions.

**The machine data plate
is located on the left front corner
of the sink.**

Please have this information ready if you call for service assistance.

The USGBC and the CaGBC Member Logos are trademarks owned by the U.S. Green Building Council and The Canadian Green Building Council, respectively, and are used by permission. The logos signify only that Champion Industries, and Moyer Diebel are USGBC and a CaGBC members; USGBC and CaGBC do not review, certify nor endorse the products or services offered by its members.

REGISTER YOUR PRODUCT ONLINE

Make sure you are connected to the internet then enter the address below.

In the U.S.A

<http://www.championindustries.com/register>

<http://www.moyerdiebel.com/register>

In Canada

<http://www.championindustries.com/canada/register>

PRODUCT REGISTRATION BY FAX

COMPLETE THIS FORM AND FAX TO:

(336) 661-1660 in the USA

1-(800) 204-0109 in Canada

PRODUCT REGISTRATION CARD

Model	Serial #
-------	----------

Date of Installation: ___/___/___

Company Name: _____

Address: _____
(Street) Province Postal Code

Telephone #: () _____ --- _____

Contact: _____

Installation Company: _____

Address: _____

Telephone #: _____

Contact: _____

FAILURE TO REGISTER YOUR PRODUCT MAY VOID YOUR WARRANTY

IMPORTANT IMPORTANT

Revision History

A revision might be a part number change, a new instruction, or other information that was not available at print time. We reserve the right to make changes to these instructions without notice and without incurring any liability by making the changes. Equipment owners may request a revised manual, at no charge, by calling 1 (800) 858-4477 in the USA or by calling 1 (800) 263-5798 in Canada.

Revision Date	Revised Pages	Serial Number Effectivity	Revision Description
4.4.14	All	PP314010010	Released First Addition
1.5.15	16-17	All	Updated Item 6, 7 part numbers

LIMITED WARRANTY

Champion Industries Inc. (herein referred to as Champion), 3765 Champion Blvd., Winston-Salem, North Carolina 27105, and P.O. Box 301, 2674 N. Service Road, Jordan Station, Canada, LOR 1S0, warrants machines, and parts, as set out below.

Warranty of Machines: Champion warrants all new machines of its manufacture bearing the name "Champion" and installed within the United States and Canada to be free from defects in material and workmanship for a period of one (1) year after the date of installation or fifteen (15) months after the date of shipment by Champion, whichever occurs first. [See below for special provisions relating to glasswashers.] Warranty registration must be submitted to Champion within ten (10) days after installation either online on the Champion Industries website (<http://www.championindustries.com/register>) in the USA or <http://www.championindustries.com/canada/register> in Canada or by fax on the form provided at the front of this manual. If warranty registration is not returned to Champion within such period, the warranty will expire after one year from the date of shipment. Champion will not assume any responsibility for extra costs for installation in any area where there are jurisdictional problems with local trades or unions. If a defect in workmanship or material is found to exist within the warranty period, Champion, at its election, will either repair or replace the defective machine or accept return of the machine for full credit; provided; however, as to glasswashers, Champion's obligation with respect to labor associated with any repairs shall end (a) 120 days after shipment, or (b) 90 days after installation, whichever occurs first. In the event that Champion elects to repair, the labor and work to be performed in connection with the warranty shall be done during regular working hours by a Champion authorized service technician. Defective parts become the property of Champion. Use of replacement parts not authorized by Champion will relieve Champion of all further liability in connection with its warranty. In no event will Champion's warranty obligation exceed Champion's charge for the machine. The following are not covered by Champion's warranty:

- a. Lighting of gas pilots or burners.
- b. Cleaning of gas lines.
- c. Replacement of fuses or resetting of overload breakers.
- d. Adjustment of thermostats.
- e. Adjustment of clutches.
- f. Opening or closing of utility supply valves or switching of electrical supply current.
- g. Cleaning of valves, strainers, screens, nozzles, or spray pipes.
- h. Performance of regular maintenance and cleaning as outlined in operator's guide.
- i. Damages resulting from water conditions, accidents, alterations, improper use, abuse, tampering, improper installation, or failure to follow maintenance and operation procedures.
- j. Wear on Pulper cutter blocks, pulse vanes, and auger brush.

Examples of the defects not covered by warranty include, but are not limited to: (1) Damage to the exterior or interior finish as a result of the above, (2) Use with utility service other than that designated on the rating plate, (3) Improper connection to utility service, (4) Inadequate or excessive water pressure, (5) Corrosion from chemicals dispensed in excess of recommended concentrations, (6) Failure of electrical components due to connection of chemical dispensing equipment installed by others, (7) Leaks or damage resulting from such leaks caused by the installer, including those at machine table connections or by connection of chemical dispensing equipment installed by others, (8) Failure to comply with local building codes, (9) Damage caused by labor dispute.

Warranty of Parts: Champion warrants all new machine parts produced or authorized by Champion to be free from defects in material and workmanship for a period of 90 days from date of invoice. If any defect in material and workmanship is found to exist within the warranty period Champion will replace the defective part without charge.

DISCLAIMER OF WARRANTIES AND LIMITATIONS OF LIABILITY. CHAMPION'S WARRANTY IS ONLY TO THE EXTENT REFLECTED ABOVE. CHAMPION MAKES NO OTHER WARRANTIES, EXPRESS OR IMPLIED, INCLUDING, BUT NOT LIMITED, TO ANY WARRANTY OF MERCHANTABILITY, OR FITNESS OF PURPOSE. CHAMPION SHALL NOT BE LIABLE FOR INCIDENTAL OR CONSEQUENTIAL DAMAGES. THE REMEDIES SET OUT ABOVE ARE THE EXCLUSIVE REMEDIES FOR ANY DEFECTS FOUND TO EXIST IN CHAMPION DISHWASHING MACHINES AND CHAMPION PARTS, AND ALL OTHER REMEDIES ARE EXCLUDED, INCLUDING ANY LIABILITY FOR INCIDENTALS OR CONSEQUENTIAL DAMAGES.

Champion does not authorize any other person, including persons who deal in Champion dishwashing machines to change this warranty or create any other obligation in connection with Champion Dishwashing Machines.

Table of Contents

PP3 - Power Wash Sink System

<i>Revision History</i>	<i>i</i>
<i>Limited Warranty</i>	<i>ii</i>
<i>Model Description</i>	<i>iv</i>
Installation	1
<i>Receiving</i>	<i>1</i>
<i>Placement</i>	<i>1</i>
<i>Electrical Connections</i>	<i>3</i>
<i>Water Connections</i>	<i>4</i>
<i>Drain Connections</i>	<i>4</i>
<i>Chemical Dispensing Provisions</i>	<i>4</i>
Operation	5
<i>Assembling the Sink</i>	<i>5</i>
<i>Control Panel Description and Water Level Sensor</i>	<i>6</i>
<i>Normal Operating Mode</i>	<i>7</i>
<i>Loading and Cleaning Wares</i>	<i>8</i>
<i>Delay Off Operating Mode</i>	<i>11</i>
Cleaning and Maintenance	12
<i>Cleaning</i>	<i>12</i>
<i>De-liming</i>	<i>12</i>
<i>Maintenance</i>	<i>12</i>
<i>Troubleshooting</i>	<i>13</i>
Service Replacement Parts	15
Electrical Schematics	26

Model Description

Standard Model Description

208-240V/60/1 and 3 PH

14 gauge, Type 304 stainless tanks and drainboards

11" high x 2-1/2" deep backsplash

Twist-handle drain valves

Stainless steel legs, cross-rails, and adjustable bullet-feet

3 HP Stainless steel wash pump and impeller with permanently sealed bearings

Rear discharge

Removable strainer plates

Manual reset motor overload protection

Low water protection for wash pump

3 kW wash tank heater

Options and Accessories

480/60/3

Utensil Basket

Sheet pan racking system

Pot and pan overshelf with hooks

Table mounted overshelf

1/2" pre-rinse sprayer

3/4" faucet

Left-to-right or right-to-left direction of operation

1. Inspect the machine and shipping pallet for signs of damage.
2. Options and accessories may have shipped in separate boxes with your sink.
3. Turn to the front of this manual and follow the instructions to register your product online or by fax.

NOTE:

The installation of your power wash sink must be performed by qualified service personnel. Problems due to improper installation are not covered by the Warranty.

NOTE:

The installation of the power wash sink must comply with all local electrical, plumbing, health and safety codes or in the absence of local codes, installed in accordance with the applicable requirements in the National Electrical Code, NFPA 70, Canadian Electrical Code (CEC), Part 1, CSA C22.1; and the Standard for Ventilation Control and Fire Protection of Commercial Cooking Operations, NFPA 96.

4. Refer to the illustration on page 2 showing a sample PP-3 configuration.
5. Check the location of the building plumbing connections and move the unit to its permanent location.
6. Note the location of the electrical connection (1) and the drain connections (2) and (2A) in the sample illustration.

NOTE: YOUR MACHINE WILL BE DIFFERENT.

The PP-3 sink is customizable including: length of drainboards, and tanks as well as direction of operation.

7. Remove the protective wrap and any hold-down straps.
8. Carefully remove the machine from the pallet. Do not lift by the drain assemblies.
9. Using the sink adjustable feet and a bubble level, level the sink front to back and side to side. The standard height for the sink table is 34"/864mm.
10. Most installations require the sink backsplash to be sealed to the wall with sealant.

1	Electrical Connection
2	Scrap Sink Drain Connection
2A	Wash, Rinse, & Sanitizer Sink Drain Connection

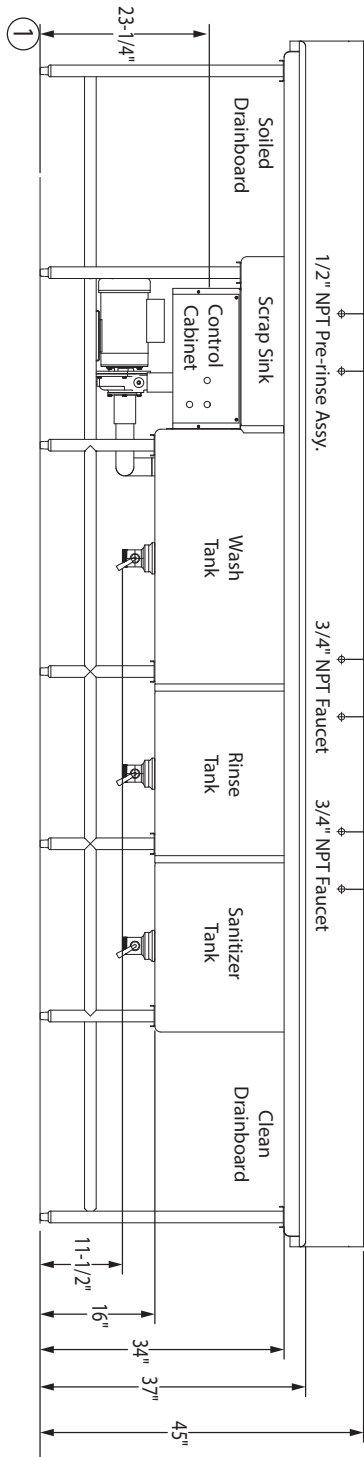
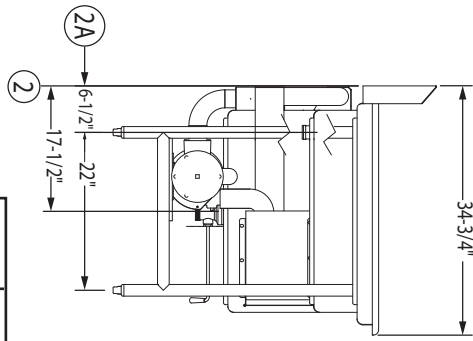
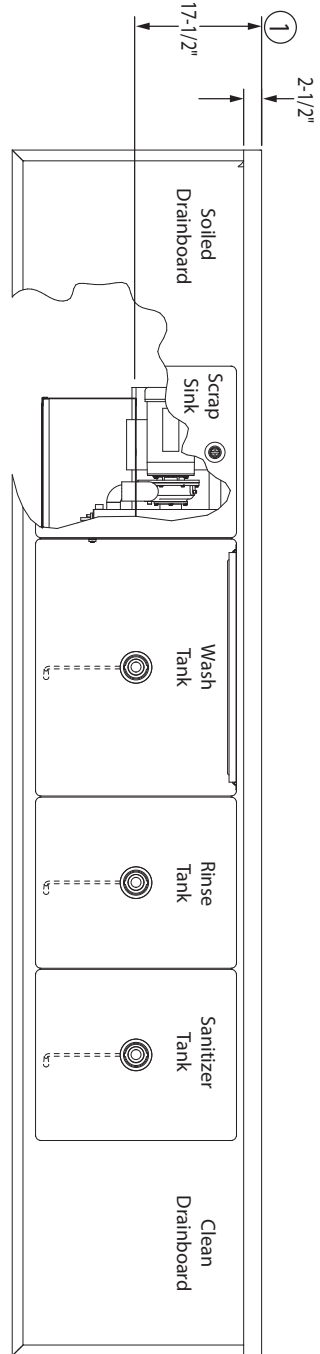

LEFT TO RIGHT

 SAMPLE CONFIGURATION

Electrical Connections



WARNING:

Electrocution or serious injury may result when working on an energized circuit.

Disconnect power at the main breaker or service disconnect switch before working on the circuit.

Lock-out and tag the breaker to indicate that work is being performed on the circuit.

! ATTENTION !

A qualified electrician must connect the main incoming power to the sink in accordance with all local codes and regulations or in the absence of local codes in accordance with the National Electrical Code or the Canadian Electrical Code. Improper installation will not be covered by the Limited Warranty.

Connecting Incoming Power Supply

1. Make sure the incoming power is disconnected at the main disconnect switch or circuit breaker.
2. The sink is available for either single or three phase operation. Standard voltages are 208-240V/60/1 & 3, and 480V/60/3.
3. A Machine Electrical Connection Data Plate is located in proximity to the input terminal block. Make sure the incoming power supply matches the machine electrical connection data plate before connecting the incoming power.
4. Remove the fasteners on the front of the control cabinet and lower the hinged panel.
5. Connect rigid or flexible conduit to the control cabinet through the supplied access hole in the rear.
6. Connect the power wires to the gray input terminal blocks and the ground wire to the green input terminal block.
7. Close the control cabinet.

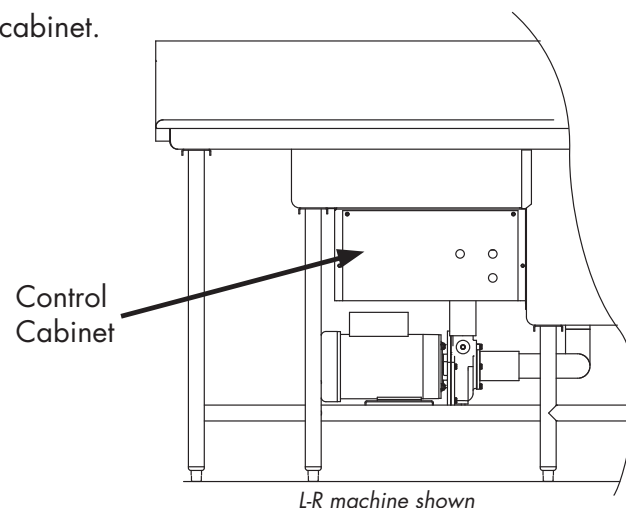

Water Connections

! ATTENTION !

A qualified plumber must connect the water supply to the sink in accordance with all local plumbing and sanitation codes and regulations.
Improper installation will not be covered by the Limited Warranty.

Sink Faucets

1. **HOT WATER** — 3/4" NPT, 120°F/49°C maximum temperature, with a recommended minimum incoming flowing pressure of 45 PSI measured at the sink.
COLD WATER — 3/4" NPT, 75°F/24°C maximum temperature, with a recommended minimum incoming flowing pressure of 45 PSI measured at the sink.
2. A water hardness of 3 grains/gal (US) [51.3 mg/L] or less is recommended.
3. A manual shut-off valve, 3/4" or larger, should be installed in the hot and cold water supply line as close to the sink as possible for servicing.

Pre-rinse Sprayer

1. **HOT WATER** — 1/2" NPT, (minimum 115°F/46°C, maximum 125°F/52°C) temperature, with a recommended minimum incoming flowing pressure of 45 PSI measured at the sink.
COLD WATER — 1/2" NPT, 75°F/24°C maximum temperature, with a recommended minimum incoming flowing pressure of 45 PSI measured at the sink.
2. A water hardness of 3 grains/gal (US) [51.3 mg/L] or less is recommended.
3. A manual shut-off valve, 1/2" or larger, should be installed in the hot and cold water supply line as close to the sink as possible for servicing.

Drain Connections

1. Sink Drains — 2" NPT
2. Scrapper Drain — 1-1/2" NPT

Chemical Provisions

1. Wash Tank Detergent — Non-sudsing, safe for hands, aluminum safe.
2. Sanitizer — Contact your local chemical supplier for an approved chemical.

NOTE:

**The sink does not have chemical connection electrical provisions.
Contact your local chemical supplier for the chemicals, and dispensers designed for powered wash sinks.**

Assembling the Sink

1. Remove any protective film from sink. Check the sink interior for foreign material.
2. Make sure the sink is permanently located.
3. Make sure all utility connections are complete.
4. Make sure all of the drains are closed prior to filling the machine.
5. Contact a local chemical supplier for all necessary procedures regarding chemicals.
6. Refer to the illustration below and note how the machine is assembled.

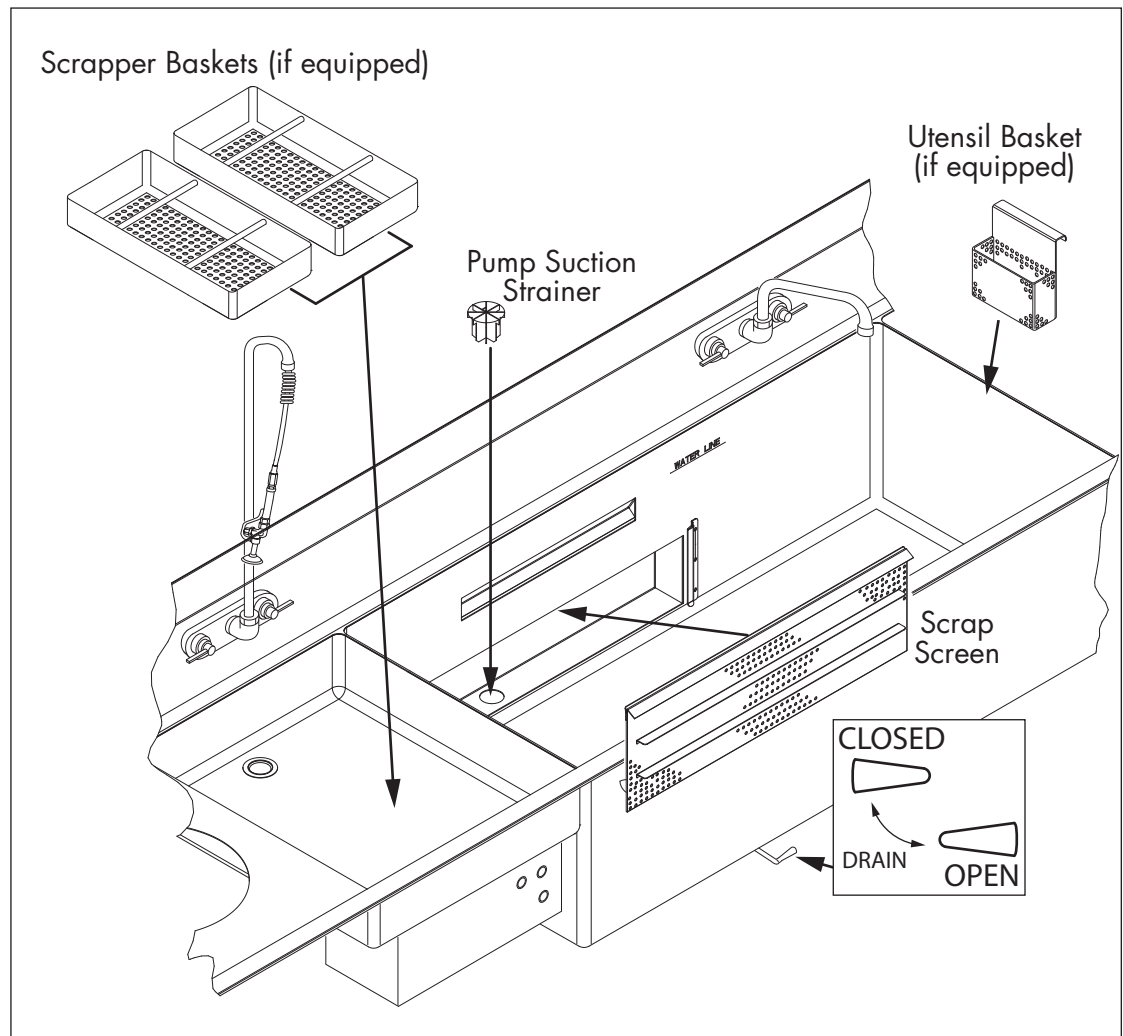

PP-3 component assembly.

! IMPORTANT !
Wear protective clothing when working around the sink including rubber apron, gloves, and eye protection.

Operation

Control Panel Description

ON PUSH BUTTON — Press to turn pumps and wash tank heater on.

OFF PUSH BUTTON — Press to turn pumps and wash tank heater off.

DELAY OFF PUSH BUTTON — Press to enter the Delay Off Mode of Operation.

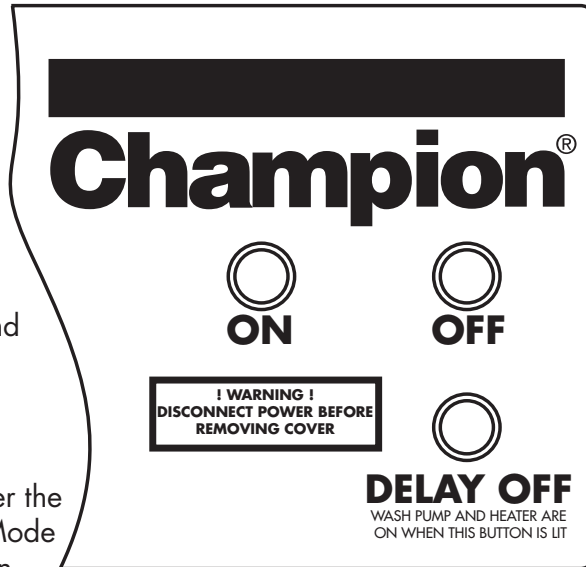

Water Level Sensor

1. The water level sensor is black in color with a hex head bolt in the center. It is located on the side wall of the wash tank compartment.
2. The water level sensor must be covered by water in order for the water heater to energize.
3. Make sure the sensor is free of oils and other food soils.

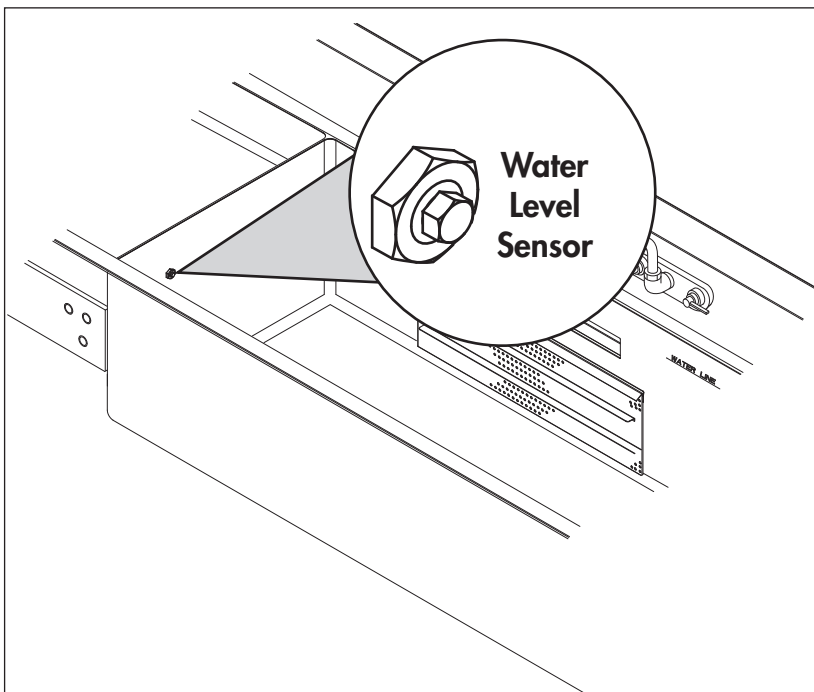

The water level sensor must be covered by water in order for the tank heater to energize.

Normal Operating Mode

Follow the steps below to operate the machine in normal mode:

1. Turn the power on at the building main circuit breaker or service disconnect switch.
NOTE: The sink does not have a power on/off switch.
2. Close the drain on each tank by turning the drain handle clockwise to the nine o'clock position. **NOTE: The handle will lock in place when fully closed.**
3. Fill the wash tank with hot water (minimum 115°F/46°C, maximum 125°F/52°C) temperature to the water line mark.
4. Add detergent to the wash tank in accordance with the chemical supplier's instructions.
5. Fill the remaining tanks to the desired levels. These tanks do not have a water line mark.
6. Add sanitizer to the sanitizing sink in accordance with the chemical supplier's instructions.

continued on next page

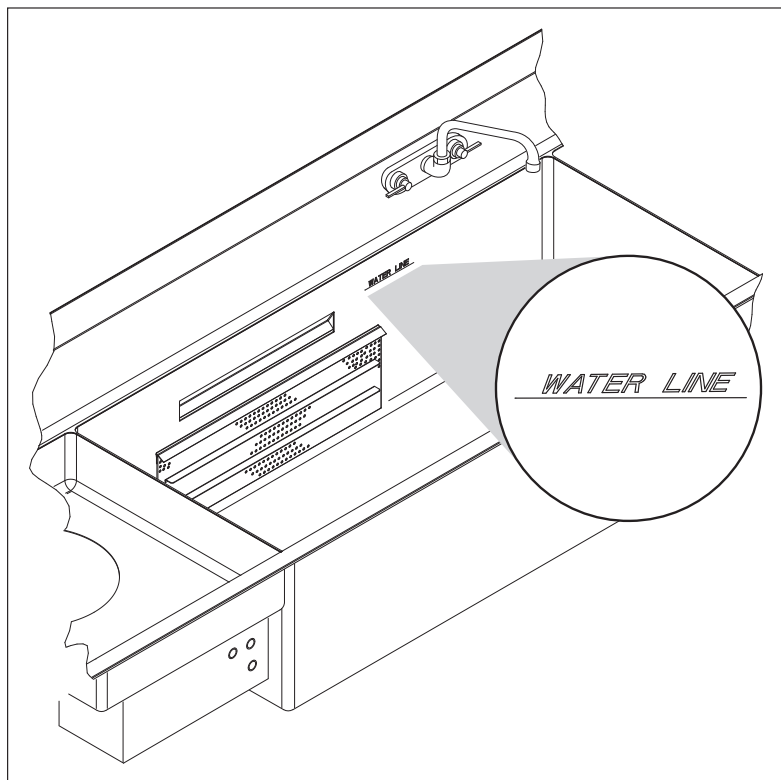

Fill the wash tank up to the "Water Line" mark located on the back wall of the compartment.

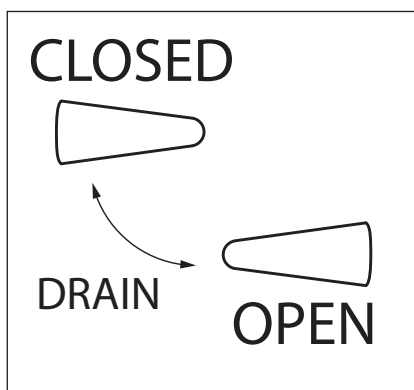

To fully close the drains, turn the drain handles clockwise to the nine o'clock position making sure it locks in place.

Normal Operating Mode

Loading and Cleaning Wares

! IMPORTANT !

The sink is designed for pots, pans, mixing bowls, baking sheets and other cooking utensils.

DO NOT WASH DISHES NOR SILVERWARE IN THE SINK.

Follow the steps below to load and clean the wares:

1. Prescrap loose food particles off the wares in the prescraping section.

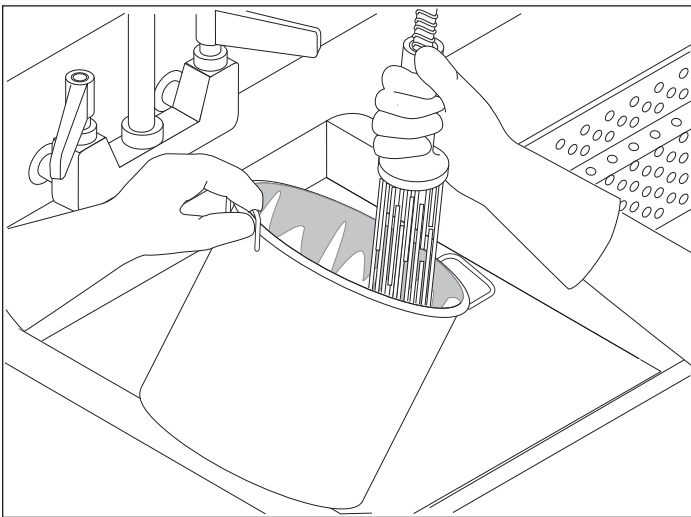

Prescrap the wares.

2. An optional utensil basket is available that hangs from the side of the wash tank to hold spoons, spatulas and other dull-edged kitchen tools.

! CAUTION !

NEVER PLACE KNIVES OR OTHER SHARP OBJECTS IN THE SINK NOR THE UTENSIL BASKET.

3. Load items into the wash tank making sure pots, and bowls lay on their sides and do not nest inside one another. Items must be fully submerged to wash properly.

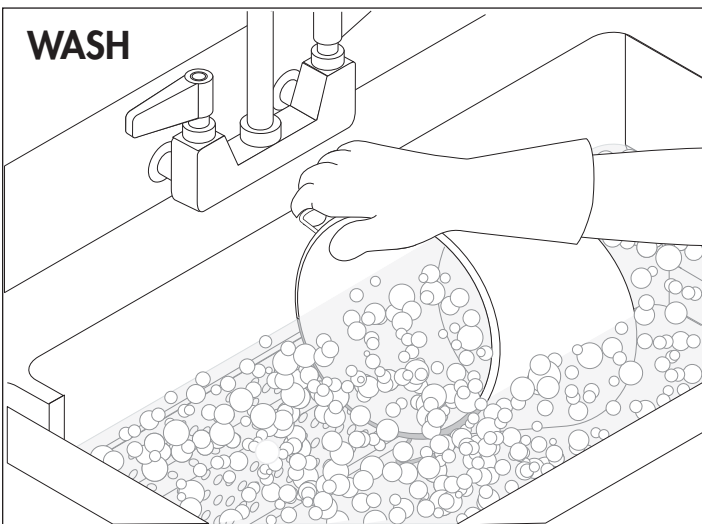

Place soiled wares in the wash tank.

NOTE:

Washing is a continuous operation. Check the cleanliness of items as they wash, remove them when they are clean and replace with soiled items as the clean ones are removed.

Normal Operating Mode

Loading and Cleaning Wares

4. Baking sheets require special loading to prevent them from nesting. An optional sheet pan rack, P/N 335126 provides a convenient way to separate and properly load baking sheets.
5. Without the optional sheet pan rack, baking sheets must be stacked in an alternating criss-cross pattern. Make sure the pans are stacked with the baking side facing up.

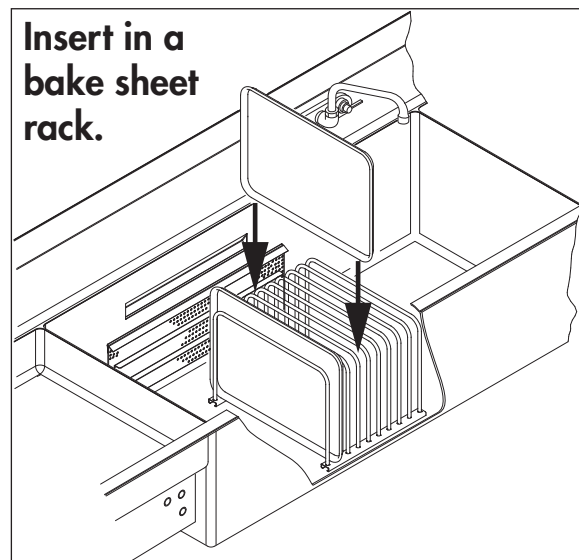
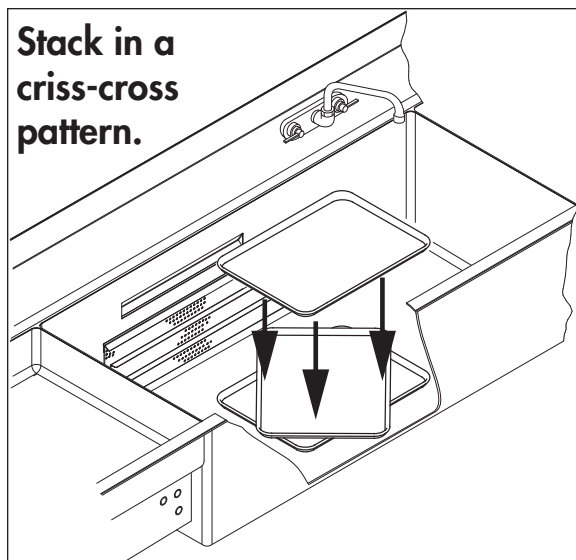

Criss-cross baking sheets or use an optional bake sheet rack, P/N 335126.

6. Push the ON push button to start the wash pump and heater.
7. Push the OFF push button periodically, check the cleanliness of the wares and remove from the wash tank as needed. Load additional wares, do not overload the tank.
8. Push the ON button to restart the wash tank pump and heater.

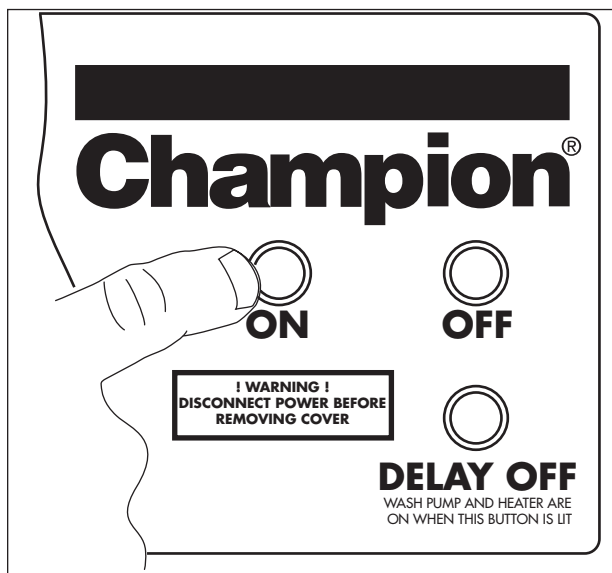

Push ON to start after wares are loaded.



Push OFF to stop when checking and unloading wares.

Operation

Normal Operating Mode

Loading and Cleaning Wares (continued)

9. Dip washed items in the rinse tank to remove soap and loosened food soils.
10. Replace the rinse water periodically to keep the water clean.

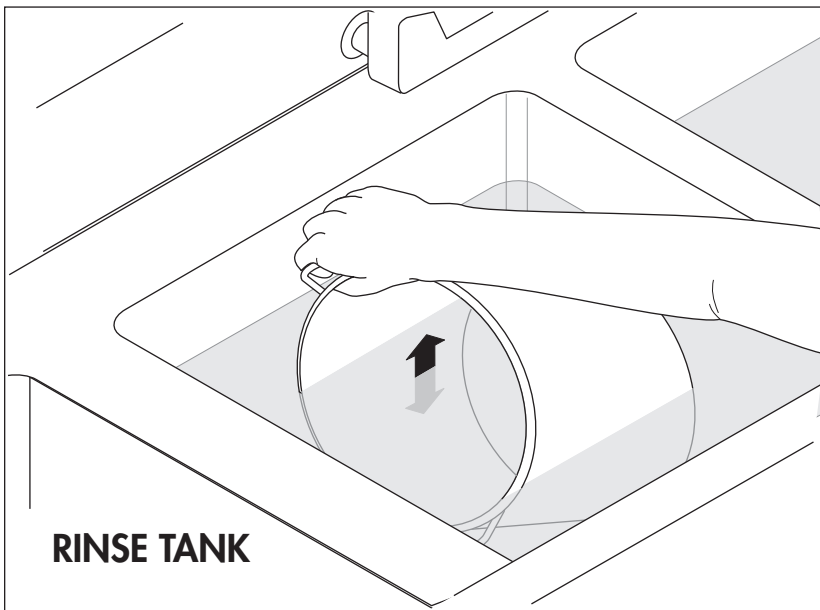

Rinse wares in the rinse tank.

11. Soak the wares in the sanitizer compartment according to the chemical supplier's instructions and local health codes.
12. Dry wares thoroughly after sanitization.

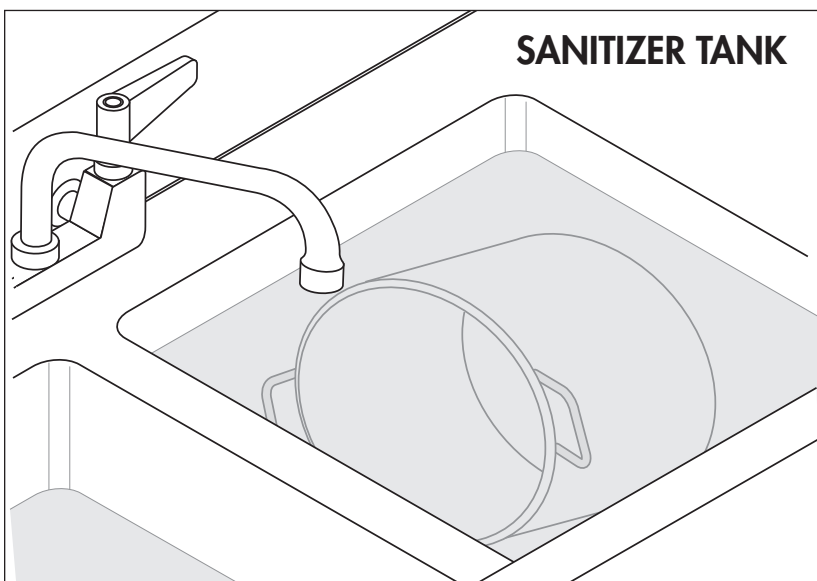

Soak wares in the sanitizer tank.

Delay Off Operating Mode

The DELAY OFF mode provides four hours of continuous automatic wash operation. At the end of the four hours the wash pump and heater turn off automatically.

Follow the instructions for normal operation on pages 7-10 to prepare the sink for the delay off mode.

Perform the steps below to start the Delay Off operating mode:

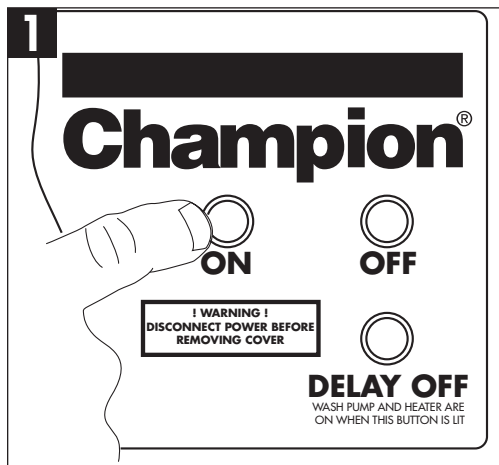

Push the ON push button to start the pumps and tank heater.

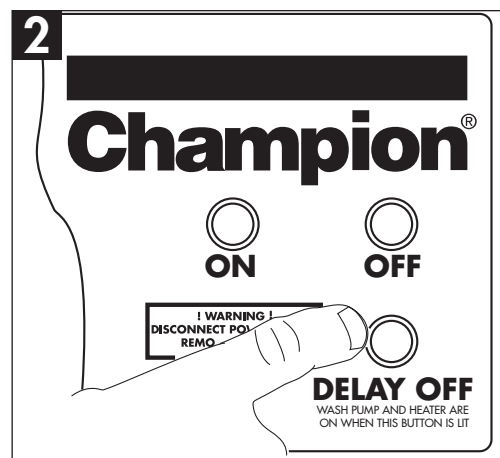

Push the DELAY OFF push button. The push button will illuminate; the pump and heater will come on.

! NOTE !

The sink will run continuously for 4 hours in the delay off mode and then turn off automatically.



Push the OFF push button to stop the delay off mode anytime during 4 hour cycle.

! IMPORTANT !

If the OFF button is pressed during the delay off mode the sink will stop.

The DELAY OFF button must be pressed again to start the delay off mode again.

The 4 hour time cycle will restart from the very beginning and run for an additional 4 hours.

4 Rinse and sanitize the wares as shown on page 10 after the delay off mode is complete.

Cleaning

Perform the steps below after each shift at the end of the day.

1. Remove any wares remaining in the sink.
2. Push the OFF push button to stop the pumps and heater.
3. Turn the drain handles to the 3 o'clock position to fully open the drains.
4. Remove the scrapper baskets, pump suction strainer and scrap screen. Thoroughly flush both sides of the screen to clean.
5. Flush the interior of the sink compartments.
6. Wipe the sink interiors with a soft cloth and mild detergent. Flush clean.
7. Check the water level sensor making sure it is clean and free of debris.
8. Reassemble the sink.

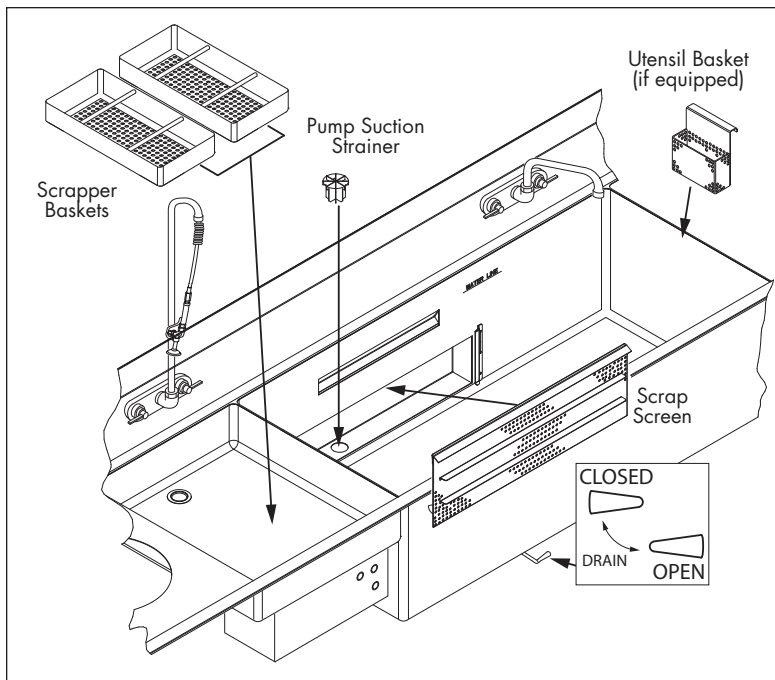

Remove the screens, pump suction strainer and scrap screen.

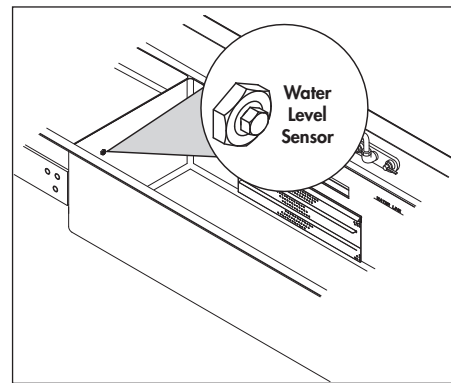

Clean the water level sensor.

De-liming

Contact your chemical supplier for de-liming chemicals and the proper procedures for de-liming the sink in the event that de-liming is required.

Maintenance

There are no lubrication points for this machine.

Contact your authorized Champion service agent for a yearly service check if desired.

Troubleshooting

Condition	Cause	Solution
Sink pump will not run.	Main breaker OFF. Control panel fuses blown.	Check breaker on panel. Contact service agent.
Low or no water.	Main water supply off.	Open supply valve.
Chemicals dispensers will not work.	Chemical supply low. Dispenser defective.	Refill chemical container. Contact Chemical Supplier.
Wash tank is sudsing over.	Non-sudsing detergent is required for operation.	Contact Chemical Supplier.
Poor wash results.	Wares incorrectly loaded in wash tank. Clogged screens. Water in sink needs changing. Chemical injectors not feeding. Tank heater defective.	Reposition wares or reduce amount of wares. Clean screens. Drain and refill sink with fresh water. Contact Chemical Supplier. Contact Service Agent.
Water temperature low in wash tank.	Water level sensor dirty. Tank was filled with cold water.	Clean water level sensor in wash tank. Drain and refill with hot water (Min. 115°F/46°C- Max. 125°F/52°C.
Sink(s) will not drain.	Drain screen(s) clogged. Drain valve defective. Building drain clogged.	Clean drain screen(s). Contact Service Agent. Contact Building Maintenance.
Pumps run constantly.	Sink may be operating in the delay off mode.	Push Off button to stop. The delay off mode will restart from the beginning and run an additional 4 hours when restarted.

***This Page
Intentionally
Left Blank***

Service Replacement Parts

Illustrations.....	Page
Control Panel Assembly	16
Control Cabinet	18
Pump/Motor Assembly	20
Wash Tank Heater Assembly	22
Screens, Faucets, Drains	24

Electrical Schematics

P/N 702765-1 Single Phase 208-240V	26
P/N 702765-2 Three Phase 208-240V	27
P/N 702765-2 Three Phase 480V	28

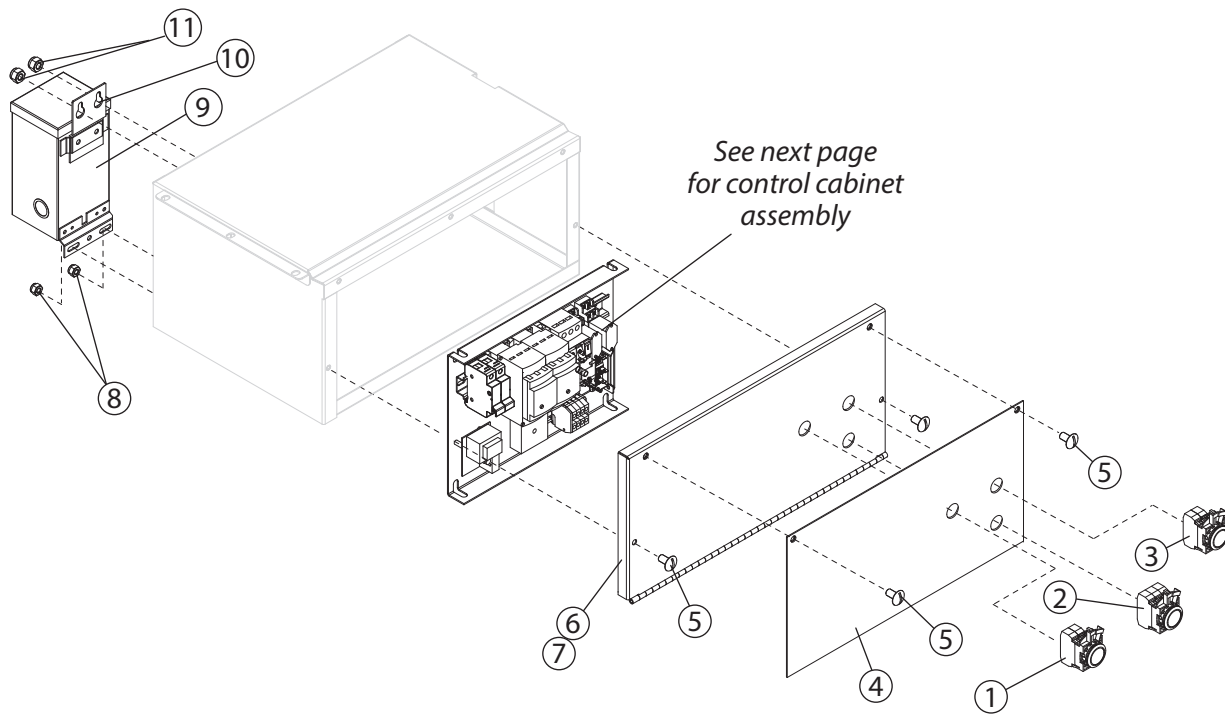

Item No.	Part No.	Description	Qty.
1	900980	ON PUSHBUTTON, GREEN	1
2	115397	DELAY OFF, PUSHBUTTON, AMBER	1
3	900981	OFF, PUSHBUTTON, RED	1
4	115392	LABEL, CONTROL PANEL	1
5	100073	SCREW, 1/4-20 X 1/2" TRUSS HD.	4
6	335123-1	PANEL, CONTROL, L-R	1
7	335123-2	PANEL, CONTROL R-L	1
8	107966	NUT, GRIP 10-32 W/NYLON INSERT	2
9	100280	TRANSFORMER, 250VA, 240/480V:120/240V	1
10	335747	BRACKET, TRANSFORMER	1
11	107967	NUT, GRIP 1/4-20 W/NYLON INSERT	2
–	107431	GASKET, SEAM (Goes around Item 6 & 7) NOT SHOWN	4 FT

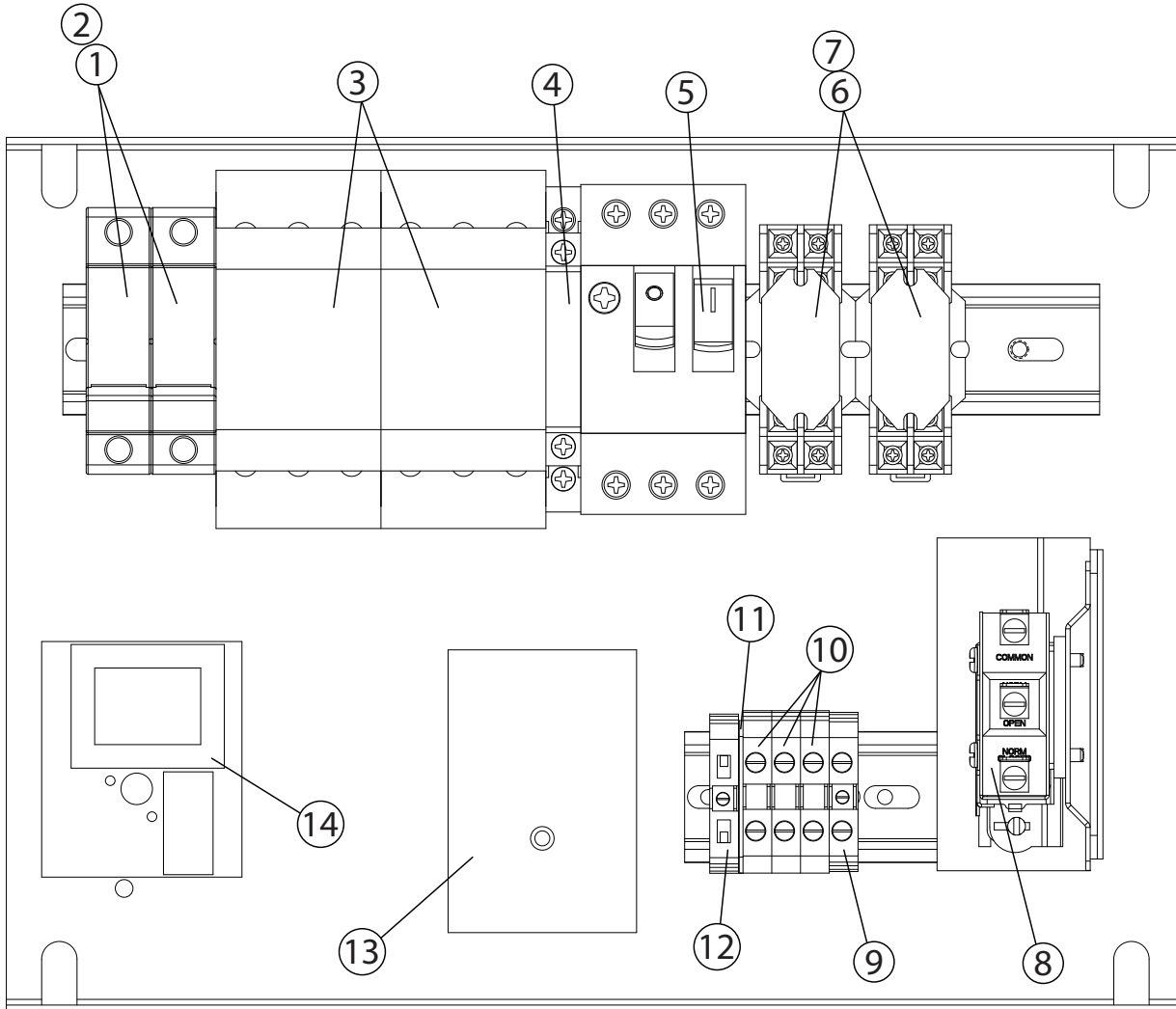

Item No.	Part No.	Description	Qty.
1	111153	BLOCK, FUSE 600V 30A	2
2	111821	FUSE, ATDR 3A, LPCC-3 (208-240V/1 and 3PH)	2
—	112484	FUSE, ATDR 1-1/2A LPCC-1-1/2 (480V/3)	2
3	114342	CONTACTOR, 12A, 220V COIL	2
4	112367	CONTACT, AUXILLIARY	1
5	111630	OVERLOAD, MTR. STARTER 13.0-18.0A (208-240V/1)	1
—	113161	OVERLOAD, MTR. STARTER 9.0-14.0A (208-240V/3)	1
—	111628	OVERLOAD, MTR. STARTER 4.0-6.3A (480V/3)	1
6	111036	SOCKET, RELAY	2
7	111069	RELAY, 2PDT 10A 240V COIL	2
8	115398	THERMOSTAT, SST BULB 125°F MAX	1
9	B501591-1	BLOCK, TERMINAL GREEN (GROUND)	1
10	B501590-1	BLOCK, TERMINAL, GRAY	A/R
11	B501592	SECTION, END	1
12	B501596	STOP, END	1
13	115395	TIMER, INFITEC 230V, (PRESET TO 4 HOURS)	1
14	115396	CIRCUIT BOARD, WATER LEVEL CONTROLLER, 240VAC	1

Pump/Motor Assembly

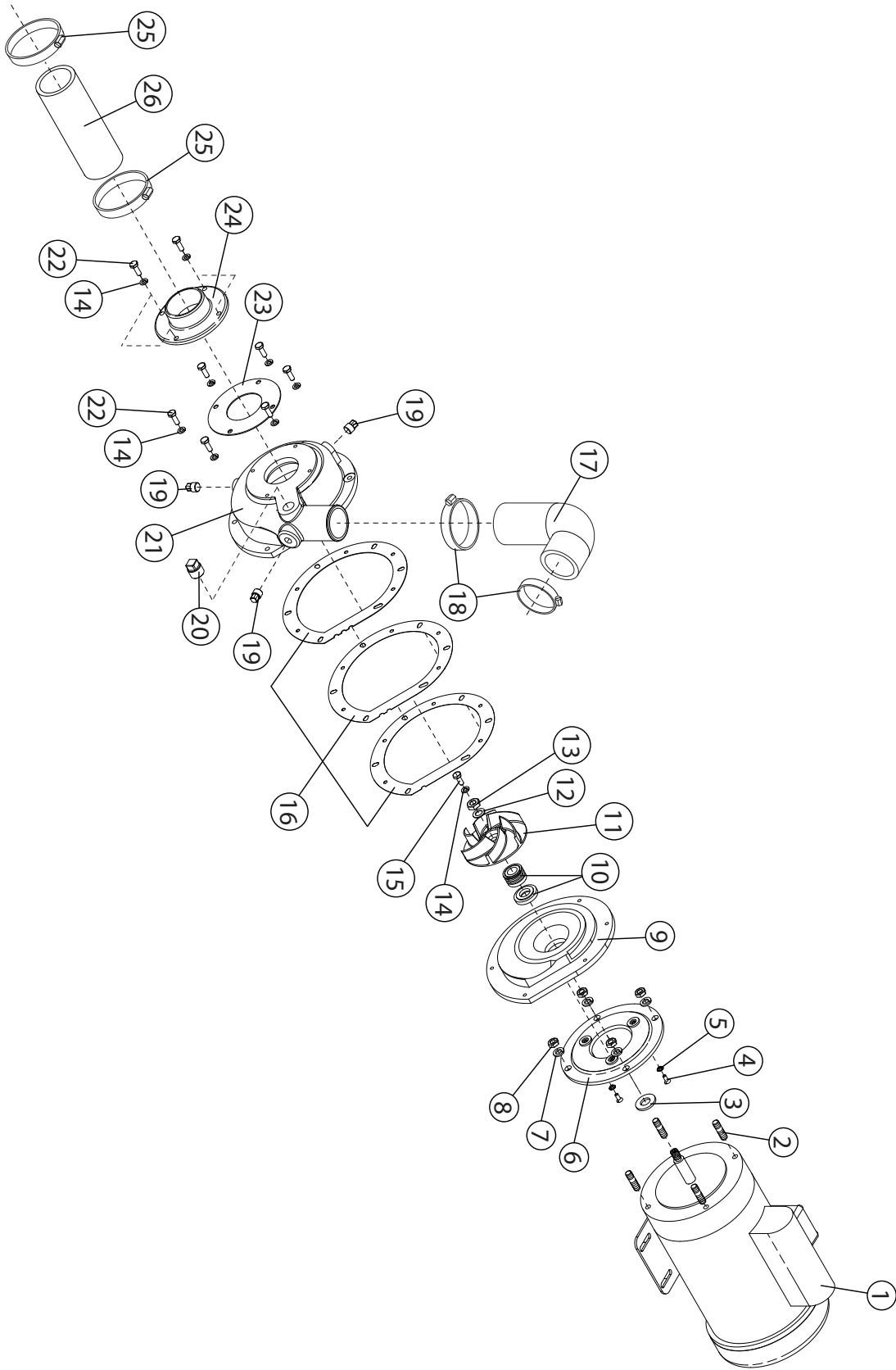

Item No.	Part No.	Description	Qty.
1	115401	MOTOR, PUMP 208-240V/60/1	1
—	111704	MOTOR, PUMP 208-240V/480V/60/3	1
2	110734	STUD, 3/8-16 X 1-3/8" SST	4
3	109654	SLINGER, WATER	1
4	100754	SCREW, FLAT HEAD 10-32 X 1/2" SST	3
5	110270	WASHER, LOCK EXTERNAL TOOTH #10	3
6	204460	PLATE, BACKING PUMP	1
7	106407	WASHER, LOCK 3/8" SPLIT SST	4
8	107690	HEX, PLAIN JAM-NUT 3/8-16 SST	1
9	113635	FLANGE, PUMP	1
10	111111	SEAL, PUMP	1
11	113120	IMPELLER, PUMP 3HP	1
12	110248	WASHER, FLAT	1
13	110247	HEX, PLAIN JAM-NUT 7/16-20 SST	1
14	106482	WASHER, LOCK 1/4" SPLIT SST	11
15	100735	BOLT, HEX HEAD, 1/4-20 X 5/8" SST	1
16	900737	KIT, PUMP SHIM KIT	1
17	207193	HOSE, PUMP DISCHARGE	1
18	104165	CLAMP, HOSE	2
19	102500	PLUG, 1/4" NPT, SQUARE HEAD BRASS	3
20	102504	PLUG, 1/2" NPT, SQUARE HEAD BRASS	1
21	113634	VOLUTE, PUMP	1
22	100736	BOLT, HEX HEAD 1/4-20 X 3/4" SST	10
23	112338	GASKET, PUMP SUCTION FLANGE	1
24	113636	FLANGE, SUCTION	1
25	105986	CLAMP, HOSE	2
26	0509767	HOSE, PUMP SUCTION	1
—	419425	PUMP/MOTOR ASSY COMPLETE 208-240V/60/1 (Does not include Items 17, 18, 25, 26)	
—	408841	PUMP/MOTOR ASSY COMPLETE 208-240V/480V/60/3 (Does not include Items 17, 18, 25, 26)	

Wash Tank Heater Assembly

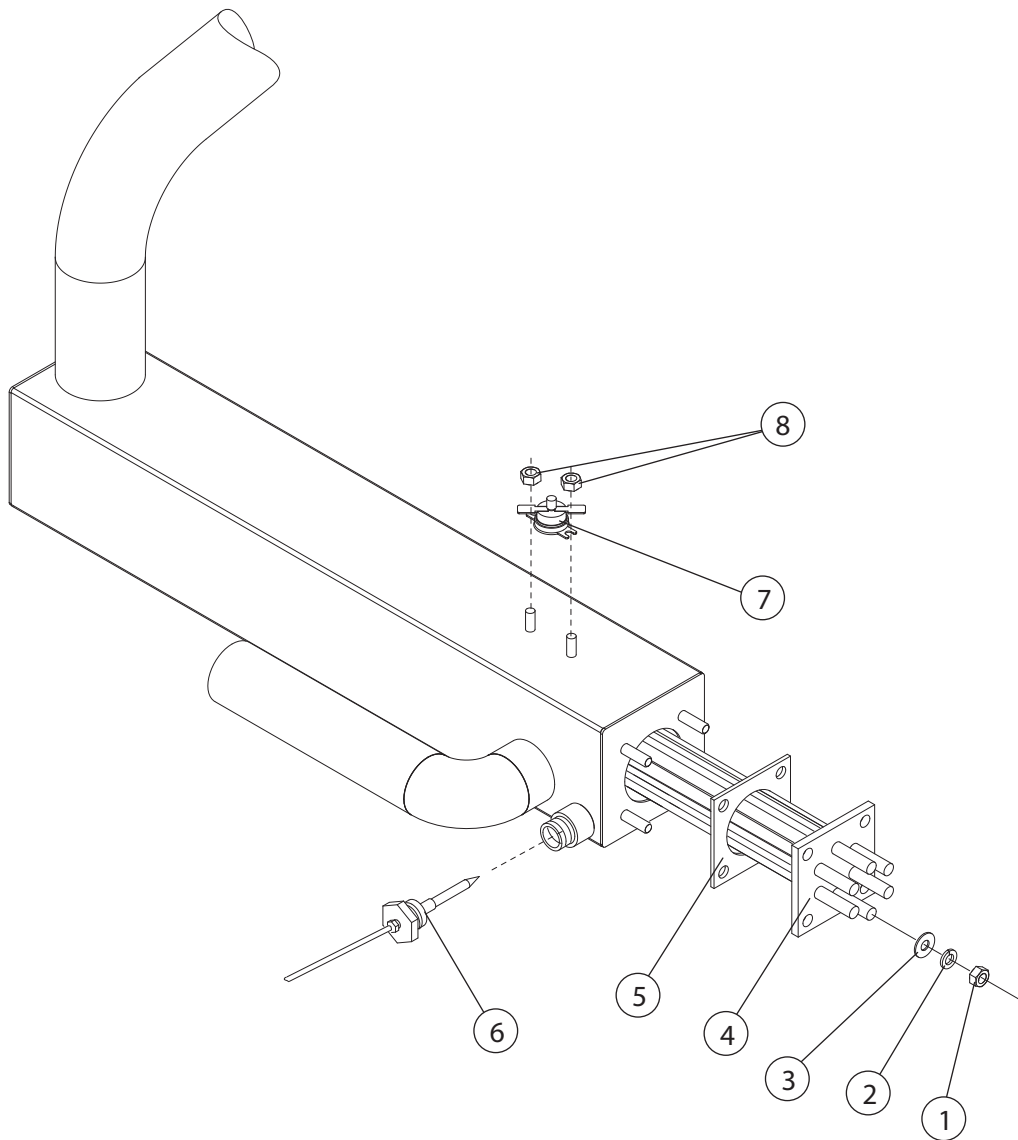

Item No.	Part No.	Description	Qty.
1	100154	NUT, PLAIN 5/16-18 SST	4
2	106013	WASHER, LOCK 5/16" SST	4
3	102376	WASHER, FLAT 5/16" SST	4
4	0509765	HEATER, 3KW 208-240V/1 AND 3 PH	1
–	0509766	HEATER 3KW 480V/3PH	1
–	115519	HEATER, 7KW 480V/3PH	1
5	108345	GASKET, HEATER	1
6	115398	THERMOSTAT, SST BULB 125°F MAX	1
7	115399	THERMOSTAT, HIGH LIMIT 140°F, (MANUAL RESET)	1
8	108954	NUT,GRIP 6-32 W/NYLON INSERT	2

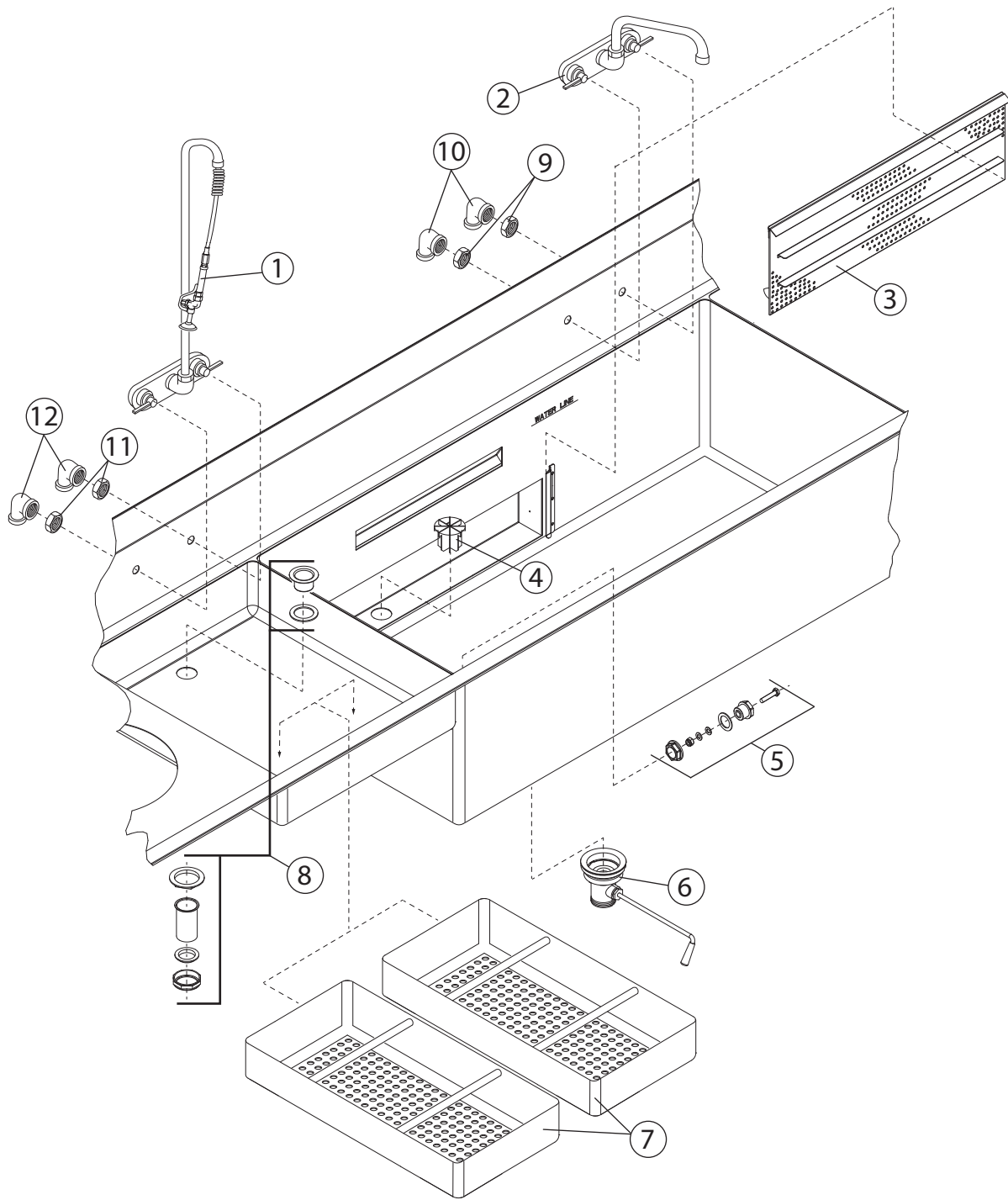

Item No.	Part No.	Description	Qty.
1	0510016	PRE-RINSE ASSY. 1/2" NPT	1
2	0510015	FAUCET, 3/4" NPT	A/R
3	0709784	SCREEN, SCRAP WASH TANK	1
4	0710105	STRAINER, SUCTION PUMP WASH TANK	1
5	0709773	SENSOR, WATER LEVEL	1
6	110529	DRAIN ASSY. TWIST LEVER 2"	A/R
7	115268	BASKET, SCRAPPER (IF EQUIPPED)	2
8	0503928	DRAIN ASSY. 1-1/2" (Comes with basket, tail, and nuts)	1
9	100156	LOCKNUT, 3/4" NPT BRASS (2 PER FAUCET)	A/R
10	102442	ELBOW, 3/4" NPT 90° BRASS (2 PER FAUCET)	A/R
11	100709	LOCKNUT, 1/2" NPT BRASS	2
12	102435	ELBOW, 1/2" NPT 90° BRASS	2

OPTIONAL BY SPECIAL ORDER:

–	0510016-T&S	T&S PRE-RINSE ASSY. 1/2" NPT	1
–	0510015-T&S	T&S FAUCET, 3/4" NPT	A/R

Electrical Schematic 208-240V/1 Phase

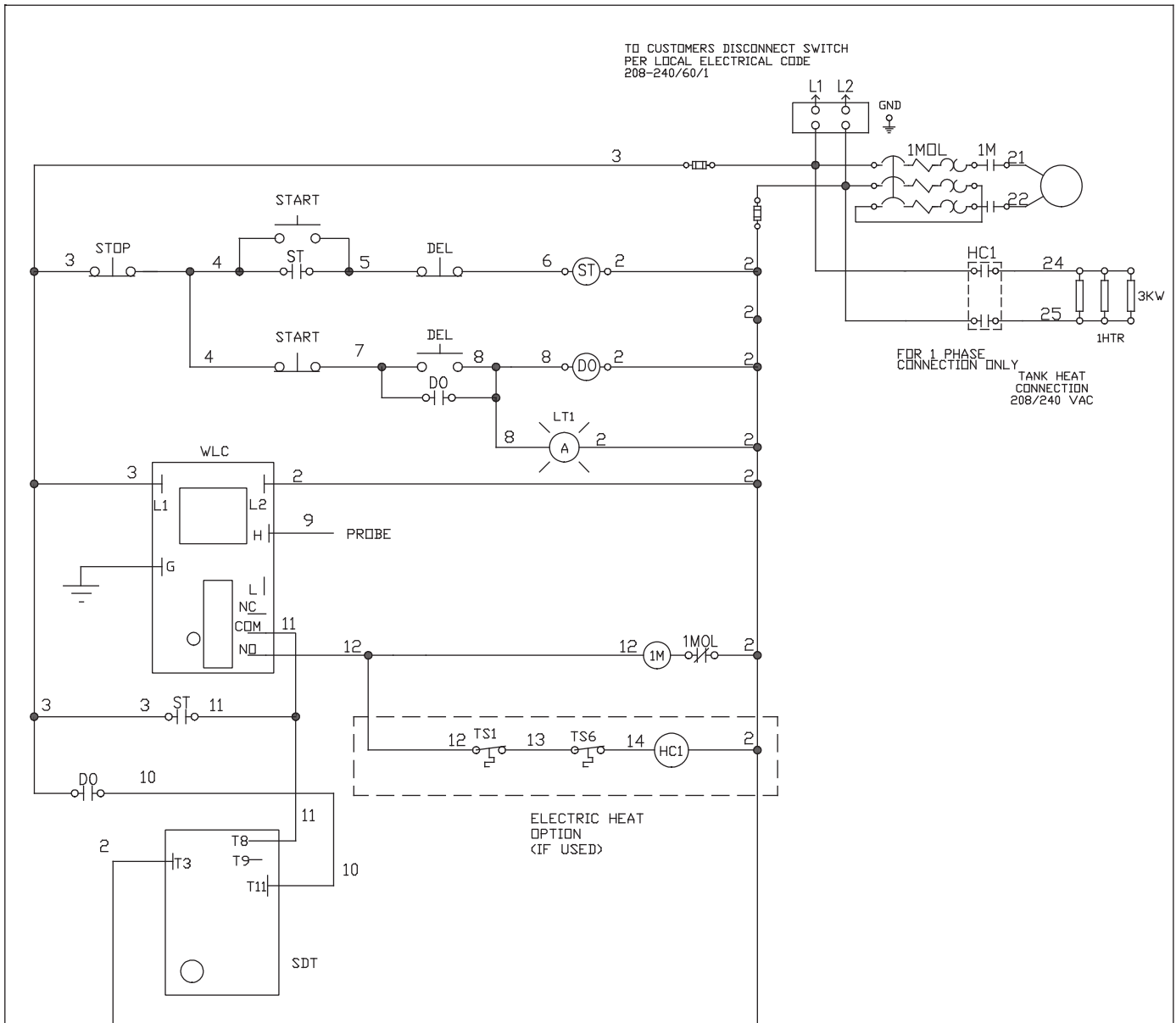

WLC	LOW WATER LEVEL CONTROL
FU	FUSE
GND	GROUND
HC1	WASH TANK CONTACTOR
1HTR	WASH TANK HEATER
LT1	DELAY OFF LIGHT
1M	PUMP MOTOR CONTACTOR
1MOL	PUMP MOTOR OVERLOAD
1MTR	PUMP MOTOR
START	PUSHBUTTON START SWITCH
DEL	PUSHBUTTON DELAY OFF
DO	DELAY OFF RELAY
T1	CONTROL TRANSFORMER
TS1	HEATER THERMOSTAT
HLTS	HEATER SAFETY THERMOSTAT
DT	DELAY OFF TIMER
ST	START RELAY

MODEL	DATE	NUMBER/REV
PP-3 1 PHASE	12FEB13	702765-1

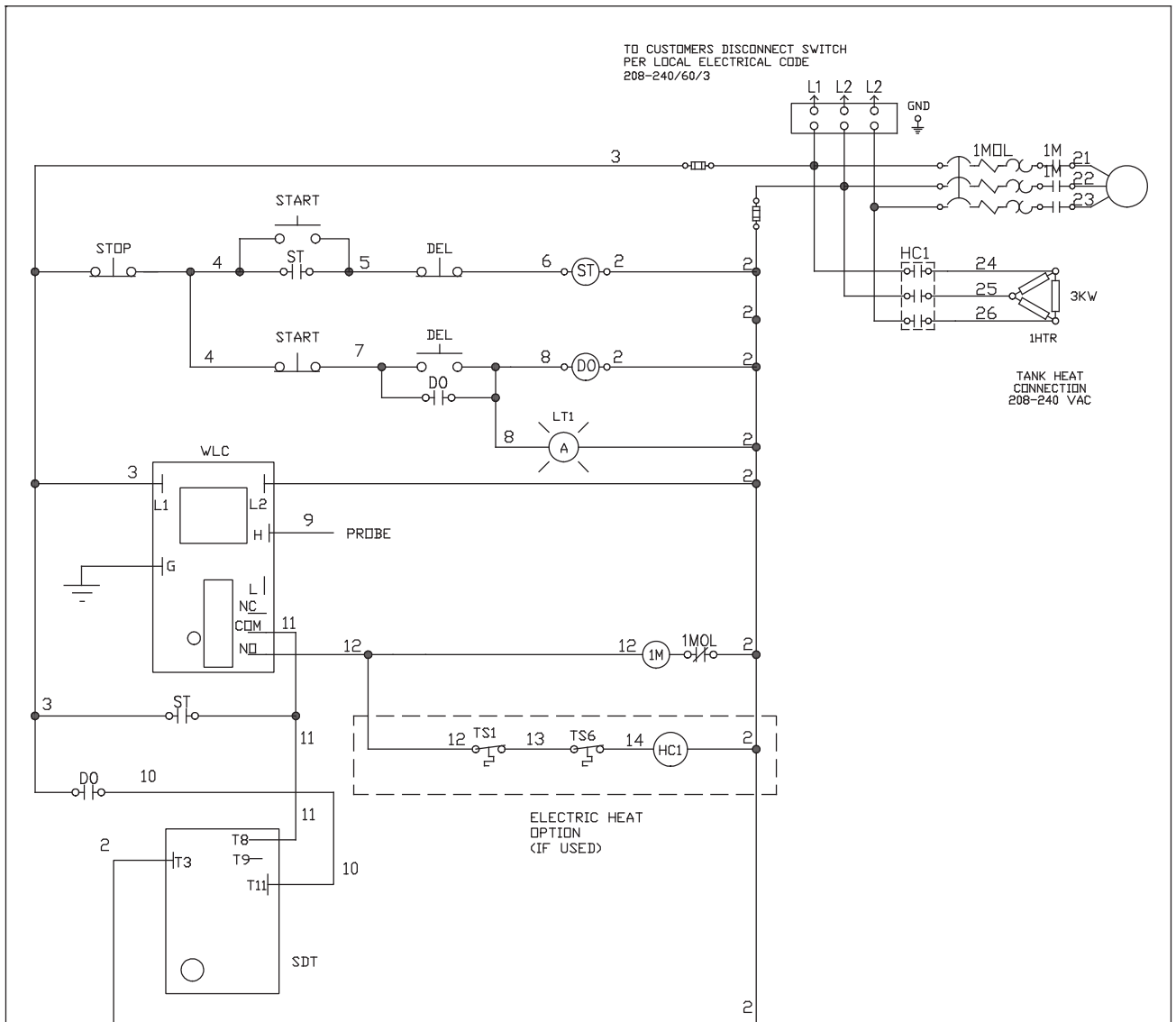

WLC	LOW WATER LEVEL CONTROL
FU	FUSE
GND	GROUND
HC1	WASH TANK CONTACTOR
1HTR	WASH TANK HEATER
LT1	DELAY OFF LIGHT
1M	PUMP MOTOR CONTACTOR
1MOL	PUMP MOTOR OVERLOAD
1MTR	PUMP MOTOR
START	PUSHBUTTON START SWITCH
DEL	PUSHBUTTON DELAY OFF
DO	DELAY OFF RELAY
T1	CONTROL TRANSFORMER
TS1	HEATER THERMOSTAT
HLTS	HEATER SAFETY THERMOSTAT
DT	DELAY OFF TIMER
ST	START RELAY

MODEL	DATE	NUMBER/REV
PP-3 3 PHASE	15APR13	702765-2

Electrical Schematic 480V/3 Phase

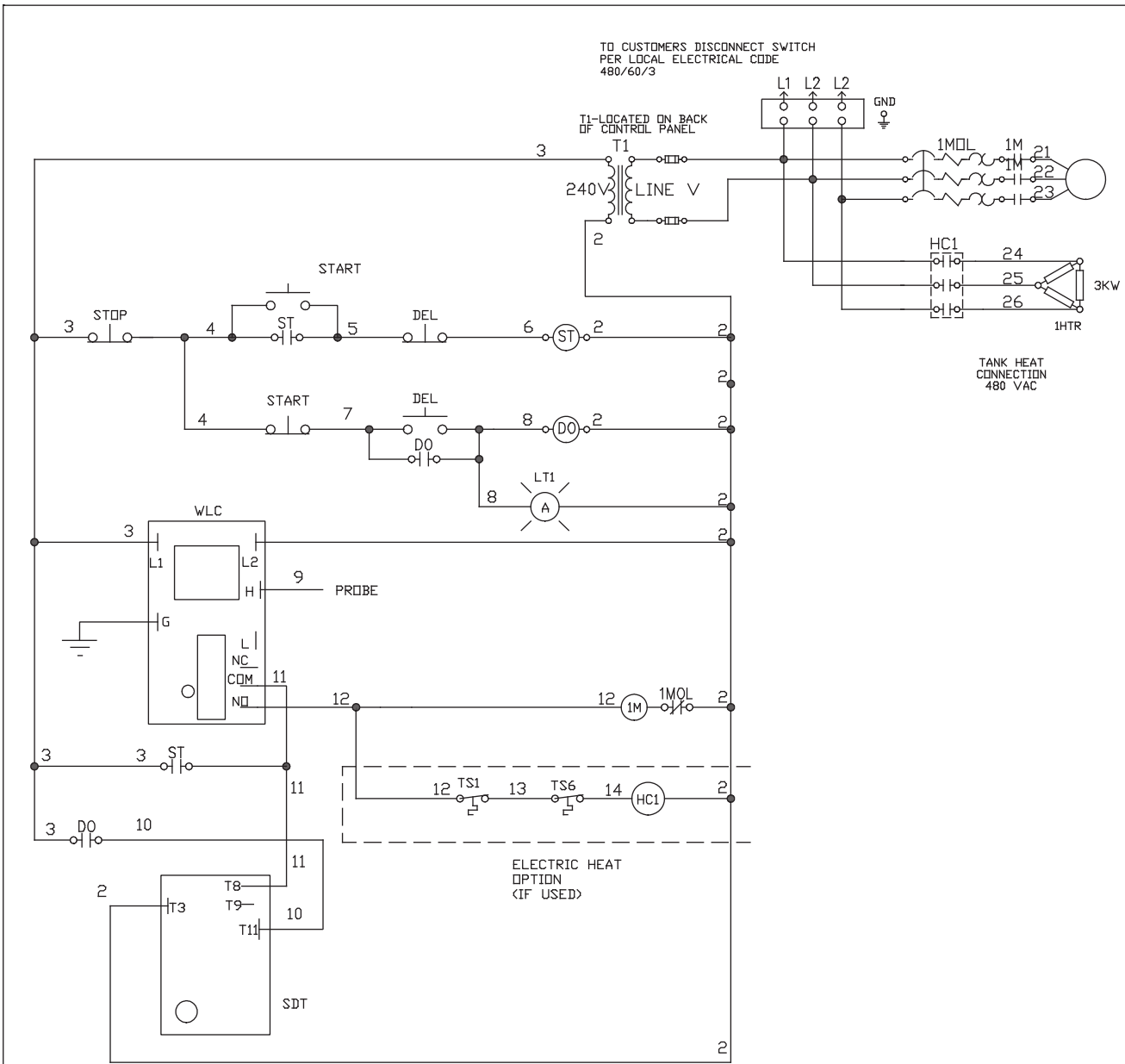

CB	CIRCUIT BREAKER
WLC	LOW WATER LEVEL CONTROL
FU	FUSE
GND	GROUND
HC1	WASH TANK CONTACTOR
1HTR	WASH TANK HEATER
LT1	POWER ON LIGHT
1M	PUMP MOTOR CONTACTOR
1MOL	PUMP MOTOR OVERLOAD
1MTR	PUMP MOTOR
START	PUSHBUTTON START SWITCH
ON	POWER ON SWITCH
DO	POWER SWITCH DELAY OFF
T1	CONTROL TRANSFORMER
TS1	HEATER THERMOSTAT
TS6	HEATER SAFETY THERMOSTAT
SDT	SHUT DOWN TIMER

MODEL	DATE	NUMBER/REV
PP-3 3 PHASE	13MAR13	702765-3