

Champion[®]

The Dishwashing Machine Specialists

For machines beginning with S/N 90922 through 99999,
and S/N J1050 and above

Technical Manual

NSN	MODEL	APL/CID	HEAT	FEED
7320-01-492-0431	250-USN-72	43A010064	Steam	R-L
7320-01-466-8334	250-USN-72	431070018	Steam	L-R
7320-01-481-9078	185-USN-72	43A000032	Steam	R-L
7320-01-481-9081	185-USN-72	43A000033	Steam	L-R
7320-01-481-9084	135-USN-72	43A000034	Steam	R-L
7320-01-481-9085	135-USN-72	43A000035	Steam	L-R
7320-01-481-9088	85-USN-72	43A000036	Steam	R-L
7320-01-482-8288	85-USN-72	43A000037	Steam	L-R
7320-01-481-9075	60-USN-72	43A000038	Steam	R-L
7320-01-481-9077	60-USN-72	43A000039	Steam	L-R
7320-01-506-0547	250-USN-72	Pending	Electric	R-L
7320-01-506-6296	250-USN-72	Pending	Electric	L-R
7320-01-506-0543	185-USN-72	Pending	Electric	R-L
7320-01-506-6292	185-USN-72	Pending	Electric	L-R
7320-01-506-6287	135-USN-72	Pending	Electric	L-R
7320-01-506-0565	85-USN-72	Pending	Electric	R-L
7320-01-506-6324	85-USN-72	Pending	Electric	L-R
7320-01-506-0566	60-USN-72	Pending	Electric	R-L
7320-01-507-0567	135-USN-72	43A030104	Electric	R-L

Rack Conveyor Dishwasher

Model
USN-72
High Temperature
Two Tank Rack Conveyor
with MRAN 90°



TMIN: 12345678



PSN: 12345678

Visit the Champion Internet Website at:
<http://www.championindustries.com/products/detail/189>
for the latest information on U.S. Navy Shipboard Warewashing Systems

Issue Date: 2.20.13

Champion Manual P/N 112804 rev. W

Complete the information below for quick reference.

Model Number _____ Serial Number _____

Voltage and Phase _____

Factory Authorized Service Centers and Marine Products Installers

Headquarters

The Source
502 Rotary Street
Hampton, VA 23661
Tel: 1 (757) 825-1400
1 (800) 497-2144
Fax: 1 (757) 825-1202

San Diego Office

The Source (San Diego)
2101 Wilson Ave.
National City, CA 91950
Tel: 1 (619) 474-4143
Fax: 1 (619) 474-4160

Mayport Office

The Source (Mayport)
1840 Mealy Street
Atlantic Beach, FL 32233
Tel: 1 (904) 241-4982
1 (888) 889-0291
Fax: 1 (904) 241-4039

Website: www.thesource2000.net
Equipment Information HQ - Darlene Ehrenfried
Parts Information HQ - Lori Hicks
Service Information HQ - Jim Luther
U.S. Navy POC - Judy Lowman, HQ
U.S. Navy POC - Nigel Pearce, San Diego, CA
U.S. Navy POC - Tony Cox, Mayport, FL
U.S. Navy POC - Janet Searls, Norfolk, VA

Email:
darlene.ehrenfried@thesource2000.com
lori.hicks@thesource2000.com
jim.luther@thesource2000.com
judy.lowman@thesource2000.com
nigel.pearce@thesource2000.com
tony.cox@thesource2000.com
janet.searls@thesource2000.com

Please call for your Authorized- NSU Warranty Start up today!

Machine Data Plate with
Model & Serial Number
located on left front
corner of the lower panel

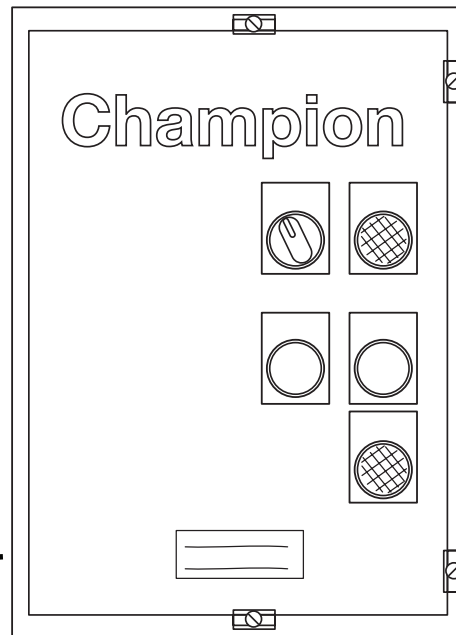

TECHNICAL PUBLICATION SHEET

TECHNICAL MANUAL VALIDATION CERTIFICATE

APPROVAL AND PROCUREMENT RECORD

**TECHNICAL MANUAL
DEFICIENCY/EVALUATION REPORT (TMDER)
(Form - NAVSEA 9086/10, REV. 6/85)**

REVISION RECORD

Revision Date	Revised Pages	Serial Number Effectivity	Comments
4/29/98	All	90922	First Issue of Manual and replacement parts lists
3/16/00	All	J1050	Added electric tank heat to and revised chain tensioner
3/9/01	58-59	J1051	Added end panels, front panels, revised leg assy
3/9/01	60-61	J1051	Revised tank fill piping assy
3/9/01	62-63	J1051	Revised final rinse piping assy
3/9/01	66a-67a	J1051	Revised track and guide assy
3/9/01	68a-69a	J1051	Revised chain tension assy
3/9/01	70-71	J1051	Added end panel
3/9/01	86-87	J1051	Revised drain assy
3/9/01	90-91	J1050	Revised control cabinet
3/9/01	90a-90b	J1051	Revised control cabinet
3/9/01	94-102	J1080	Added MRAN 90°
3/9/01	104-107	J1080	Added CH-60 Electric Booster (For USS RAmage Only)
2/27/02	61,63	J1534	Added new vacuum breakers and kits
2/27/02	71		Replaced P/N's 112606 and 112607 with new part numbers 113398 and 113399.
4/8/02	102		Corrected spacer number for bubble 16 to 15.
	103		Corrected part number 111064 to 111603 and 111605. Corrected motor clamp from 314351 to 325622.
4/30/02	71		Replaced part number 112608 and 112783 with 110164. Added V-belt 100795.
7/31/02	67, 67a	J1616	Replaced part number 112708 with part part numbers 900840 and 113509.
1/20/03	Front Cover		Added APL numbers.
1/21/03	10,11		Corrected connection points from 3/4" to 1/2" on hot water supply lines to dishwasher connections.
1/23/03	20		Added prime switches to drawing and control functions.

REVISION RECORD (CONTINUED)

Revision Date	Revised Pages	Serial Number Effectivity	Comments
1/23/03	88, 89	J1698	Added P/N 109069 control thermostat.
6/23/03	91, 91a		Revised part number for selector switch.
8/13/03	59	J1589	Revised P/N 317331 to 325351.
8/13/03	60, 63		Revised plastic style vacuum breakers with bronze style.
8/14/03	85	J1332	Revised P/N 111841 to 112379 and 112338 pump flange with gasket.
8/14/03	92-93,92a-93a 92b-93b		Inserted new replacement kits for selector switches, pushbuttons, lighted switches
8/14/03	93,93a,93b		Replaced Furance (Siemens) overloads with Telemecanique (Square D) .
11/6/03	11, 13, 14-16, 21	J1872	Insert new junction box location and installation information.
11/6/03	76b, 77b	J1872	Inserted new pages for terminal block and strip drawing and parts.
11/06/03	82a, 83a	J1872	Inserted new pages for wash and rinse tank junction boxes drawings and parts.
11/06/03		J1872	Inserted new schematics and interconnection drawings.
10/13/04	58, 59	J1921	Inserted additional curtain and curtain rods in between wash and rinse tanks.
3/16/05	101		Corrected part number for item 8 from 208386 to 202381. Inserted note for crank direction.
10/20/08	92-93	J1050	Updated Serial Number Effectivity for Controls
1/19/09	58-64	J08122570	Revised Temperature Gauge locations, Part Nos. and panels.
1/19/09	68-69	J08122570	Revised conveyor bearing assembly and Part Nos.
1/19/09	Electrical Schematics	J018122570	Added Electrical Schematic 701830 Rev. A and Electrical Schematic 702067 Rev. 0
1/19/09	120-132	J08122570	Added Field Conversion Instructions, Kit 453393 to replace Champion CH-60 Booster Assembly with C-57 Modified Booster Assembly
4/9/09	120-132	J08122570	Revised Kit 453393 Conversion Piping
4/9/09	110	J08122570	Added C57 Assembly to Standard Parts List
4/9/09	72-73	All S/N's	Revised Conveyor Drive Sheaves & Sprockets
7/28/09	1-21	Appendixes	Added USN72 C57 Booster Conversion Instructions w/Hatco Parts Replacement List
3/11/10	110	J08122570	Corrected P/N of C57 Booster to P/N 453403
7/29/10	61	J08122570	Changed Item 11 from P/N 111779 to 104749

REVISION RECORD (CONTINUED)

Revision Date	Revised Pages	Serial No. Effectivity	Comments
9/30/10	IFC, 57	All	Updated contact information
9/30/10	68-69, 68a-69a	All	Added new Bearing Seal Plate Assy., P/N 418379
Appendixes	119	All	Added TLS Installation Instructions P/N 900948
12/6/10	68-69, 68a-69a	All	Improved illustration and description of bearing assembly
5/20/11	84-85	All	Changed Item 27 to P/N 112338 & Item 35 to P/N 104640
1/10/12	85	All	Changed description of P/N 452331 Pump/Motor Assy, Complete LH to (Wash for L-R machine) (Rinse for R-L machine)
2/20/13	IFC, 57	All	Updated contact information

SAFETY SUMMARY

Safety Symbols

- The following symbols appear throughout this manual alerting you to potential hazards. Statements associated with each symbol are printed in *italics*.



WARNING:

Warning statements indicate any condition or practice that could result in personal injury or possible loss of life.



CAUTION:

Caution statements indicate any condition or practice which, if not strictly observed or remedied, could result in damage to or destruction of the dishwasher.



NOTE:

Note statements indicate any condition or practice which, if observed, will help in the safe completion of a task.

General Safety Rules

- The following general safety rules must be observed in addition to the specific cautions and warnings presented in this manual.
- Your Champion dishwasher is a heated machine using very hot water to clean and sanitize a variety of wares. Machine surfaces and wares become hot during and immediately following normal operations. Consult your supervisor and wear protective gear as directed to avoid possible injury.
- Your dishwasher contains moving conveyor parts. Use caution when working around the dishwasher especially when loading or unloading wares.
- Operators must NOT bypass a safety interlock or control to operate the dishwasher.
- The service and maintenance instructions contained in this manual are intended for qualified service personnel. These instructions assume that you are trained in basic electricity and mechanical theory. If you are not a trained technician, then do not attempt to adjust or repair the dishwasher as serious personal injury or damage to the dishwasher may result.

Warning and Caution Statement Listing

- The following listing gives the page number and text of all the warning and caution statements that appear in this manual.

Warning Statements

- Pg. 8- The installation of this unit must conform to local codes or, in the absence of local codes, to the National Electrical Code and all National Codes governing plumbing, sanitation, safety and good trade practices.
- Pg. 10- The installation of water supplies must conform to local codes or, in the absence of local code, all National Codes governing plumbing, sanitation, safety and good trade practices.
- Pg. 10- The installation of steam supplies must conform to local codes or, in the absence of local code, all National Codes governing plumbing, sanitation, safety and good trade practices.
- Pg. 12- The installation of drains must conform to local codes or, in the absence of local code, all National Codes governing plumbing, sanitation, safety and good trade practices.
- Pg. 12- The installation of ventilation must conform to local codes or, in the absence of local code, all National Codes governing plumbing, sanitation, safety and good trade practices.
- Pg. 13- The installation of electrical supplies and controls must conform to local codes or, in the absence of local codes, the National Electrical Code and good trade practices.
- Pg. 13- Dangerous voltages are present at the local electrical distribution system.
Dangerous voltages are present at the dishwasher when it is connected to the local electrical distribution system.
- Pg. 13- When working on the dishwasher, disconnect the electric service and place a red tag at the disconnect switch to indicate work is being done on that circuit.
- Pg. 14- The installation of electrical supplies and controls must conform to local codes or, in the absence of local codes, the National Electrical Code and good trade practices.
- Pg. 14- Dangerous voltages are present at the local electrical distribution system.
Dangerous voltages are present at the dishwasher when it is connected to the local electrical distribution system.
- Pg. 14- When working on the dishwasher, disconnect the electric service and place a red tag at the disconnect switch to indicate work is being done on that circuit.
- Pg. 24- Dangerous voltages are present at the local electrical distribution system.
Dangerous voltages are present at the dishwasher when it is connected to the local electrical distribution system.
- Pg. 24- When working on the dishwasher, disconnect the electric service and place a red tag at the disconnect switch to indicate work is being done on that circuit.
- Pg. 25- Perform the following checks before placing the machine into service for normal operation.
- Pg. 25- Never bypass a safety device in order to operate the dishwasher for normal operation.
- Pg. 26- The conveyor drive contains moving parts.
Use caution when working around the conveyor drive assembly.
- Pg. 27- Perform the following checks before placing the machine into service for normal operation.

SAFETY SUMMARY (Cont.)

Warning Statements (Cont.)

- Pg. 27- Never bypass a safety device in order to operate the dishwasher for normal operation.
- Pg. 28- Dishwasher surfaces, dishracks and wares become hot during and immediately after washing operations.
Wear protective gear per your supervisor's directions.
- Pg. 29- Dishwasher surfaces, dishracks and wares become hot during and immediately after washing operations.
Wear protective gear per your supervisor's directions.
- Pg. 32- Deliming solutions or other acids must not come in contact with household bleach (sodium hypochlorite) or any chemicals containing chlorine, iodine, bromine, or fluorine.
Mixing will cause hazardous gases to form.
Skin contact with deliming solutions can cause severe irritation and possible chemical burns.
- Pg. 32- Consult your chemical supplier for an appropriate deliming solution, protective gear and safety procedures.
- Pg. 33- When working on the dishwasher, disconnect the electric service and place a red tag at the disconnect switch to indicate work is being done on that circuit.
- Pg. 34- When working on the dishwasher, disconnect the electric service and place a red tag at the disconnect switch to indicate work is being done on that circuit.
- Pg. 35- Do not lubricate the stainless steel conveyor chain or shaft bearings inside the dishwasher wash and power rinse tanks.
- Pg. 36- The conveyor drive contains moving parts.
Use caution when working around the conveyor drive assembly.
- Pg. 37- When working on the dishwasher, disconnect the electric service and place a red tag at the disconnect switch to indicate work is being done on that circuit
- Pg. 40- When repairing a circuit, disconnect the power at the main service disconnect switch and place a red tag at the disconnect switch to indicate that work is being performed on the circuit.*
- Pg. 40- Use Extreme Caution when performing tests on energized circuits.*
- Pg. 40- The conveyor drive contains moving parts. Use caution when working around the conveyor drive assembly.*

Caution Statements

- Pg. 5- Check piping mounted underneath dishwasher before lifting to avoid damaging the machine.
- Pg. 8- Check piping mounted underneath dishwasher before lifting to avoid damaging the machine.
- Pg. 21- *Perform the following checks before placing the machine into service.*
- Pg. 31- *Do not hose down the exterior of the machine with water.*
- Pg. 33- *Only qualified service personnel should perform preventive maintenance on the dishwasher.*
- Pg. 34- *Only qualified service personnel should perform preventive maintenance on the dishwasher.*
- Pg. 36- *Only qualified service personnel should perform preventive maintenance on the dishwasher.*
- Pg. 40- *Only qualified service personnel should perform adjustments and repairs to the dishwasher.*

LIMITED WARRANTY

Champion Industries Inc. (herein referred to as Champion), P.O. Box 4149, Winston-Salem, North Carolina 27115, and P.O. Box 301, 2674 N. Service Road, Jordan Station, Canada, L0R 1S0, warrants machines, and parts, as set out below.

Warranty of Machines: Champion warrants all new machines of its manufacture bearing the name "Champion" and installed within the United States and Canada to be free from defects in material and workmanship for a period of one (1) year after the date of installation or fifteen (15) months after the date of shipment by Champion, whichever occurs first. [See below for special provisions relating to glasswashers.] The warranty registration card must be returned to Champion within ten (10) days after installation. If warranty card is not returned to Champion within such period, the warranty will expire after one year from the date of shipment.

Champion will not assume any responsibility for extra costs for installation in any area where there are jurisdictional problems with local trades or unions.

If a defect in workmanship or material is found to exist within the warranty period, Champion, at its election, will either repair or replace the defective machine or accept return of the machine for full credit; provided, however, as to glasswashers, Champion's obligation with respect to labor associated with any repairs shall end (a) 120 days after shipment, or (b) 90 days after installation, whichever occurs first. In the event that Champion elects to repair, the labor and work to be performed in connection with the warranty shall be done during regular working hours by a Champion authorized service technician. Defective parts become the property of Champion. Use of replacement parts not authorized by Champion will relieve Champion of all further liability in connection with its warranty. In no event will Champion's warranty obligation exceed Champion's charge for the machine. The following are not covered by Champion's warranty:

- a. Lighting of gas pilots or burners.
- b. Cleaning of gas lines.
- c. Replacement of fuses or resetting of overload breakers.
- d. Adjustment of thermostats.
- e. Adjustment of clutches.
- f. Opening or closing of utility supply valves or switching of electrical supply current.
- g. Cleaning of valves, strainers, screens, nozzles, or spray pipes.
- h. Performance of regular maintenance and cleaning as outlined in operator's guide.
- i. Damages resulting from water conditions, accidents, alterations, improper use, abuse, tampering, improper installation, or failure to follow maintenance and operation procedures.
- j. Wear on Pulper cutter blocks, pulse vanes, and auger brush.

Examples of the defects not covered by warranty include, but are not limited to: (1) Damage to the exterior or interior finish as a result of the above, (2) Use with utility service other than that designated on the rating plate, (3) Improper connection to utility service, (4) Inadequate or excessive water pressure, (5) Corrosion from chemicals dispensed in excess of recommended concentrations, (6) Failure of electrical components due to connection of chemical dispensing equipment installed by others, (7) Leaks or damage resulting from such leaks caused by the installer, including those at machine table connections or by connection of chemical dispensing equipment installed by others, (8) Failure to comply with local building codes, (9) Damage caused by labor dispute.

Warranty of Parts: Champion warrants all new machine parts produced or authorized by Champion to be free from defects in material and workmanship for a period of 90 days from date of invoice. If any defect in material and workmanship is found to exist within the warranty period Champion will replace the defective part without charge.

DISCLAIMER OF WARRANTIES AND LIMITATIONS OF LIABILITY. CHAMPION'S WARRANTY IS ONLY TO THE EXTENT REFLECTED ABOVE. CHAMPION MAKES NO OTHER WARRANTIES, EXPRESS OR IMPLIED, INCLUDING, BUT NOT LIMITED TO, ANY WARRANTY OF MERCHANTABILITY, OR FITNESS OF PURPOSE. CHAMPION SHALL NOT BE LIABLE FOR INCIDENTAL OR CONSEQUENTIAL DAMAGES. THE REMEDIES SET OUT ABOVE ARE THE EXCLUSIVE REMEDIES FOR ANY DEFECTS FOUND TO EXIST IN CHAMPION DISHWASHING MACHINES AND CHAMPION PARTS, AND ALL OTHER REMEDIES ARE EXCLUDED, INCLUDING ANY LIABILITY FOR INCIDENTALS OR CONSEQUENTIAL DAMAGES.

Champion does not authorize any other person, including persons who deal in Champion dishwashing machines to change this warranty or create any other obligation in connection with Champion Dishwashing Machines.

TABLE OF CONTENTS

Revision Record	v
Safety Summary	ix-xi
Limited Warranty	xii

PART 1: GENERAL SPECIFICATIONS	1
1.1 About this Manual	1
1.2 Model Numbers	1
1.3 Standard Equipment, Options and Accessories	2
1.4 Dimensions, Capacities, Ventilation, and Utilities	3
1.5 Electrical Power Requirements	4
PART 2: INSTALLATION	5
2.1 Unpack the Dishwasher	5
2.2 Disassembly	6
2.3 Reassembly	7
2.4 Permanent Placement	8
2.5 Connections between the dishwasher and booster	8
2.6 Water Connections	10
2.7 Steam and Condensate Connections (Steam heat only)	10
2.8 Drain Connections	12
2.9 Ventilation Connections	12
2.10 Electrical Connections	13
2.11 Electrical Tank Heat Connections (Electric heat only)	14
2.12 Chemical Connections	16
PART 3: OPERATION	19
3.1 Theory of Operation	19
3.2 Description of Operator Controls and Indicators	20
3.2.1 Remote Control Cabinet	20
3.2.2 Dishwasher and Booster	21
3.3 Start-up Procedure	23
3.4 Safety and Operation Checks	25
3.5 Shutdown Procedure	29
3.6 Operation Summary	30

PART 4: CLEANING and MAINTENANCE	31
4.1 Introduction	31
4.2 Daily Cleaning Schedules	31
4.3 Delimiting Schedule	32
4.4 Preventive Maintenance Schedules	33
4.5 Lubrication Schedules	35
PART 5: BASIC SERVICE	37
5.1 Introduction	
5.2 General Troubleshooting	38
5.3 Component Repair and Replacement	40
5.3.1 Pressure Reducing Valve (PRV) Adjustment	40
5.3.2 Water Line Strainers	41
5.3.3 Vacuum Breaker Repair	41
5.3.4 Water Solenoid Valve Repair	41
5.3.5 Float Switch Replacement	42
5.3.6 Drain Valve and Overflow Assembly	42
5.3.7 Thermometer Replacement	42
5.3.8 Tank Heat Thermostat Adjustment and Replacement	43
5.3.9 Steam Booster Thermostat Adjustment and Replacement	43
5.3.10 Steam Solenoid Valve Repair	44
5.3.11 Steam Trap Repair	45
5.3.12 Steam Booster Service	45
5.3.13 Wash Manifold Restrictor Adjustment	47
5.3.14 Pump Seal Replacement	47
5.3.15 Rinse Saver Assembly Repair	48
5.3.16 Conveyor Chain Take-up Assembly Adjustment	48
5.3.17 Take-up Bearing Replacement	49
5.3.18 Drive Shaft Bearing and Seal Replacement	49
5.3.19 Door Safety Switch Replacement	50
5.3.20 Control Circuit Explanation	50
5.3.21 Control Cabinet Fuse Replacement	54
5.3.22 Motor Overload Adjustment and Replacement	54
5.3.23 Timer Settings	55
5.3.24 Control Cabinet Pilot Light Bulb Replacement	55

PART 6: REPLACEMENT PARTS	57
6.1 Introduction	57
6.2 Parts Parts Procurement	57
PART 7: ELECTRICAL SCHEMATICS	111
PART 8: APPENDIXES	119

LIST OF FIGURES

Figure 2.1 – Disassembly	6
Figure 2.2 – Connections Between Dishwasher and Steam Booster	9
Figure 2.3 – Utility Connections	11
Figure 2.4 – Remote Control Cabinet Tank Heat Connections	14
Figure 2.5 – Tank Heater Conduit Routing	15
Figure 2.6 – Remote Control Cabinet	17
Figure 3.1 – Operator Controls Remote Control Cabinet	20
Figure 3.2 – Controls and Indicators Dishwasher and Booster	21
Figure 3.3 – Conveyor Jam Switch Check	26
Figure 3.4 – Curtain Placement	30
Figure 3.5 – Spray Arm Assembly	30
Figure 4.1 – Never Lubricate These Points	35
Figure 4.2 – Conveyor Gearbox and Drive Chain Lubrication	36
Figure 6.1 – Vents, Curtains, Doors, Panels, Scrap Screens, and Water Level Gauges .	58
Figure 6.2 – Tank Fill Assembly and Temperature Gauges	60
Figure 6.3 – Final Rinse Piping Assembly	62
Figure 6.4 – Track Assembly	66
Figure 6.5 – Conveyor Shafts, Chains, Bearings, and Guides (Prior to S/N J1050)	68
Figure 6.5a — Conveyor Shafts, Chains, Bearings, and Guides (For S/N J1050 and above)	68a
Figure 6.6 – Conveyor Chain Take-Up Assembly (Prior to S/N J1050)	70
Figure 6.6a – Conveyor Chain Take-Up Assembly (For S/N J1050 and above)	70a
Figure 6.7 – Conveyor Drive Assembly	72
Figure 6.8 – Rinse Saver Assembly	74
Figure 6.9 – Steam Coil Assembly	76
Figure 6.9a — Electric Tank Heat (For machines with S/N J1050 to S/N J1871)	76a
Figure 6.9b — Electric Tank Heat (For machines with S/N J1872 and above)	76b
Figure 6.10 – Tank Steam Piping with Booster	78

**LIST OF FIGURES
(CONT.)**

Figure 6.11 – Tank Steam Piping with Booster	80
Figure 6.12 – Junction Boxes, Float Switches, Door Switches, and Thermostats (Prior to JXXXX)	82
Figure 6.12a— Junction Boxes, Float Switches, Door Switches, and Thermostats (After JXXXX)	82a
Figure 6.13 – Pump Assembly	84
Figure 6.14 – Wash Spray System (R-L Machine Shown)	86
Figure 6.15 – Drain and Overflow Assembly	88
Figure 6.16 – Steam Booster and Steam Piping Assembly	90
Figure 6.17 – Steam Remote Control Cabinet (Prior to S/N J1050)	92
Figure 6.17a — Electric Remote Control Cabinet (For S/N J1050 and above)	92a
Figure 6.17b— Steam or Electric Control Cabinet (For S/N J1080 and above)	92b
Figure 6.18 – Dishracks and PRV	94
Figure 6.19 — MRAN 90° Guides	96
Figure 6.20 — MRAN 90° Pawl Bar	98
Figure 6.21 — MRAN 90° Table and Drain Assembly	100
Figure 6.22 — MRAN 90° Base Assembly	102
Figure 6.23 — MRAN 90° Drive and Motor Assembly	104
Figure 6.24 — CH-60 Electric Booster Piping (For USS Ramage Only)	106
Figure 6.25 — CH-60 Electric Booster Piping (For USS Ramage Only)	108

LIST OF TABLES

Table 3.1 – Controls and Indicators Remote Control Cabinet	20
Table 3.2 – Controls and Indicators Dishwasher and booster	22

PART 1: GENERAL SPECIFICATIONS

1.1 About this Manual

All information, illustrations and specifications contained in this manual are based upon the latest product information available at the time of publication. Champion constantly improves its products and reserves the right to make changes at any time or to change specifications or design without notice and without incurring any obligation.

Manual Organization

This manual is divided into seven parts:

- ◆ Part 1, General Specifications, introduces this manual and the dishwasher in general.
- ◆ Part 2, Installation, discusses the installation of the dishwasher and describes the connection of utilities and services.
- ◆ Part 3, Operation, discusses theory of operation, operator controls, initial start up and shutdown procedures.
- ◆ Part 4, Cleaning and Maintenance, discusses lubrication, preventive maintenance, cleaning and deliming.
- ◆ Part 5, Basic Service, discusses basic troubleshooting, service procedures, and corrective maintenance.
- ◆ Part 6, Replacement Parts, discusses replacement parts procurement and provides parts diagrams and parts lists.
- ◆ Part 7, Electrical Schematics, contains the dishwasher electrical schematic.

1.2 Model Numbers

USN-72

The USN-72 series is a two-tank, high temperature (180°F/82°C rinse), sanitizing rack conveyor dishwasher. This model features electric or steam heat and external booster. The USN-72 is available in either right to left or left to right conveyor operation.

The USN-72 comes in the following models:

250-USN-72: 250 racks /hour

185-USN-72: 185 racks /hour

135-USN-72: 135 racks /hour

85-USN-72: 85 racks /hour

60-USN-72: 60 racks /hour

1.3 Standard Equipment

- ◆ Modular construction for easy installation
- ◆ Deep tank design to withstand 15° list without water slosh
- ◆ Heavy duty dual chain drive with rear lugs
- ◆ Lift-out doors
- ◆ Open construction without panels for easy service and cleaning
- ◆ Exhaust vent extended to table level on each end
- ◆ All 304 stainless steel construction
- ◆ Flanged feet for deck mounting

- ◆ Interchangeable upper and lower spray arms
- ◆ 2 HP drip proof pump/motor assemblies
- ◆ 1/4 HP conveyor drive motor
- ◆ Make up water with constant flow during operation
- ◆ Dishwasher shutdown below 180°F final rinse temperature via thermal switch

- ◆ Manual fill for wash/rinse tank with water level sight gauges
- ◆ Manual Ball valve drain in each tank plumbed to a common connection
- ◆ Steam piping without threaded joints in tanks

- ◆ Remote mounted NEMA 4X control cabinet
- ◆ Common utility connections
- ◆ 440/60/3 power supply
- ◆ 120VAC control circuit
- ◆ Steam coil or electric tank heat
- ◆ Detergent/Chemical connection provisions
- ◆ Float switch low water heat protection with 5 second delay
- ◆ Door safety switches
- ◆ Conveyor jam limit switch
- ◆ Easily removable scrap screens
- ◆ Rinse saver device for water conservation
- ◆ Dishracks (peg rack and flat bottom rack)

Options and Accessories

- ◆ External steam booster heater 40° or 70° rise (specified at time of order)
- ◆ External electric booster heater 40° or 70° rise (specified at time of order)
(stainless steel, completely interplumbed and interwired)
- ◆ Right to left or left to right conveyor operation (specified at time of order)
- ◆ Choice of conveyor speed (250, 185, 135, 85, or 60 racks per hour)
(specified at time of order)
- ◆ Power unloader
- ◆ 90° motorized rack advance conveyor (specify load or unload)
- ◆ Dishracks - dish or open (specify type)
- ◆ Table limit switch, unmounted (recommended on all conveyor installations)

1.4 Dimensions, Capacities, Ventilation, and Utilities

Dimensions	
Height	56.188 inches (w/o piping)
Width	25.0 inches
Length	72.0 inches (w/o vents)
Volume crated	125 cu. ft.
Shipping weight crated	1000 lbs.
Weight uncrated	850 lbs.

Capacities	
Wash tank	22.0 gallons
Rinse tank	22.0 gallons
Final rinse flow	300.0 gal/hr @ 20 psig
Wash make up	60.0 gal/hr @ 20 psig
Total water usage	360.0 gal/hr

Rack Capacity and Conveyor Speed

Based on standard 20" X 20" dishracks manually loaded

Rack Capacity (racks/hr)	Conveyor Speed (ft/min.)
60	1.67
85	2.36
135	3.75
185	5.14
250	6.94

Ventilation (Minimum)	
Load end	200 CFM @ 1/4"S.P
Unload end	400 CFM @ 1/4"S.P.

Utilities	
Hot water:	3/4" NPT 140°F hot water connection @ 20-22 psig flow pressure
Drain:	1-1/2" NPT drain connection @ 15 gal/min maximum flow rate.
Electric:	440/60/3
Steam:	1-1/2" NPT steam connection (for machine and booster) @ 15-30 psig flow pres.
	Tank heat consumption 150 lbs./hr.
	70°R Steam booster consumption 255 lbs./hr.
Condensate:	3/4" NPT machine return to boiler (no back pressure)

1.5 Electrical Power Requirements

1.5.1 Power Requirements for Steam Heat

Machine Full Load Amps 6.9A
Operating Currents (440V/60/3 Supply)
Steam Heated

Circuit	Voltage Hz/Ph	Booster Rise (Steam)	Machine Full Load Amps	Power Requirement (125% Service Factor)
Wash motor	2.7 Amps			
Rinse motor	2.7 Amps			
Drive motor	0.4 Amps			
Control Circuit	1.1 Amps			
Motor/Control	440/60/3	70°	6.9 Amps	9.0 Amps

1.5.2 Power Requirements for Electric Heat

Machine Full Load Amps 6.9A
Operating Currents (440V/60/3 Supply)

Wash motor	2.7 Amps
Rinse motor	2.7 Amps
Drive motor	0.4 Amps
Control Circuit	1.1 Amps

Each heat circuit has a separate power source.

Heat Circuit	Voltage Hz/Ph	KW (Electric)	Amps Full Load	Power Requirement (125% Service Factor)
Wash tank heat	440/60/3	20KW	27 Amps	33 Amps
Power Rinse tank heat	440/60/3	30KW	40 Amps	50 Amps

PART 2: INSTALLATION

In This Part—

- Unpacking the dishwasher
- Disassembling the dishwasher to move through hatches
- Making Utility Connections

2.1 Unpack the Dishwasher



NOTE:

The installation of your dishwasher must meet all applicable health and safety codes and conform to good trade practice.

Your USN-72 was completely assembled, inspected, and thoroughly tested at our factory before shipment to your installation site.

- The dishwasher with vents and booster are shipped on a single pallet.
- The booster is disconnected from the dishwasher.
- The remote mounted control cabinet is shipped in a separate carton.

Perform the following steps to unpack the dishwasher:

1. Remove protective wrap and hold-downs from the pallet.
2. Inspect for any shipping damage. If damage is found, save the packing material and contact the carrier immediately.
3. Check the interior of the dishwasher for the following items stowed inside:
 - 1 set of flanged feet
 - 1 set of dishracks
 - Warranty information packet



CAUTION:

Check piping mounted underneath dishwasher before lifting, to avoid damaging the machine.

4. Remove the dishwasher from the skid.



NOTE:

If you need to move the dishwasher through shipboard hatches, refer to Part 2.2, Disassembly, on the next page.

5. Move the dishwasher to its permanent location if no disassembly is required. Refer to Part 2.4, Permanent Placement.

2.2 Disassembly

The USN-72 will require partial disassembly to move it through a standard 26" x 66" hatch. Go to Part 2.4, Permanent Placement, if disassembly is not required.

Perform the following steps to disassemble the dishwasher. Refer to Fig. 2.1 below.

1. Remove (7) 1/4-20 nuts and washers from each vent collar assembly. Pull the vent collars off the machine.
2. Disconnect the union in the upper final rinse piping assembly.
3. Disconnect the union in the wash water makeup line. Remove the upper final rinse piping assembly and the makeup line.
4. Inspect the fill piping on the top of the tanks
5. Remove (1) 1/2" locknut located inside the machine from each vertical fill pipe. Remove the upper fill pipe assemblies.
6. Turn the conveyor chain tension adjusters until the conveyor chain is slack.
7. Locate the master links in the conveyor chain and remove. Disconnect the chains and pull them to the chain adjuster in the wash tank.
8. Remove 1/4-20 hardware and U-clip protecting the inside tank joint.
9. Remove hardware securing outside front tank flange.
10. Remove the hardware joining the tank bases.
11. Disconnect the 1-1/2" drain line union underneath the dishwasher.
12. Disconnect the 1/2" steam condensate union.
13. Disconnect the 3/4" tank steam supply union between the wash and rinse tanks.
14. Disconnect and mark the wiring and conduit between the tanks.
15. Pull the wash and rinse tanks apart.
16. Move the dishwasher to its permanent location.
17. Refer to Part 2.3, Reassembly.

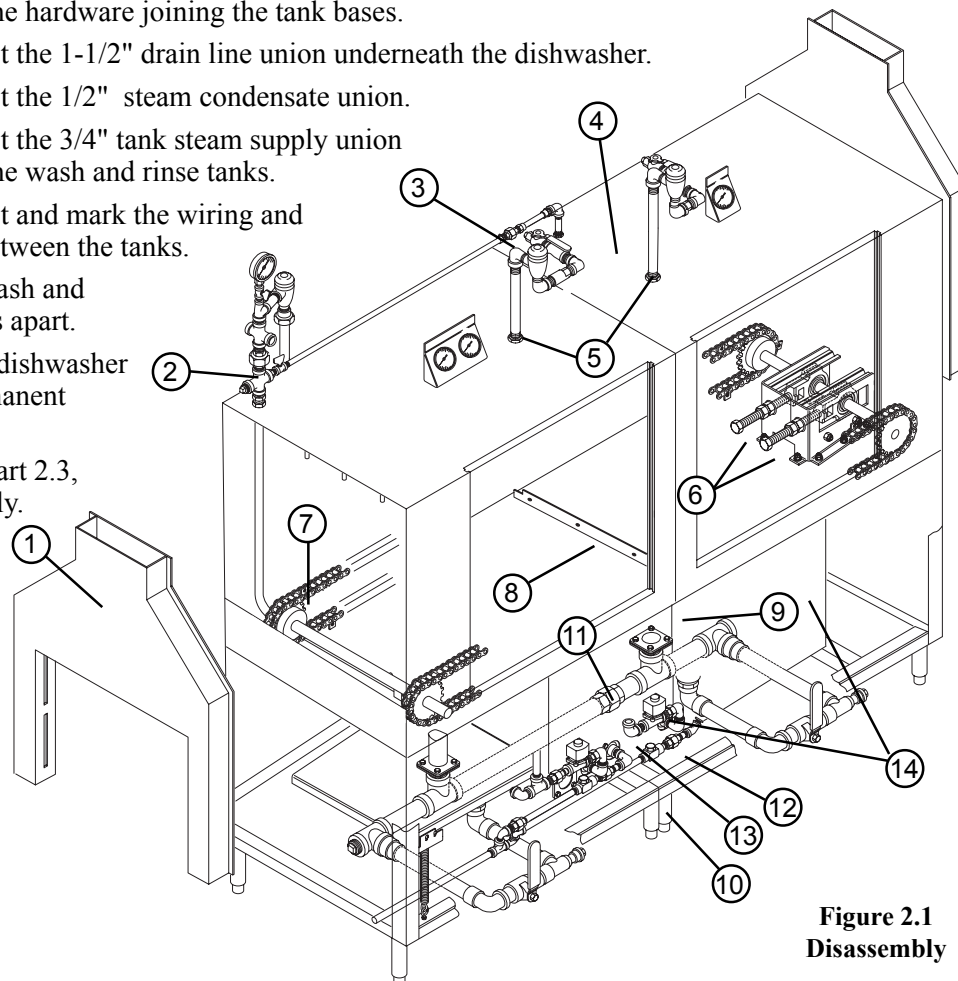

**Figure 2.1
Disassembly**

2.3 Reassembly

Special Tools and Materials Required—

- Bubble level (3 ft.)
- Silicone sealant, (1) 12 fl. ounce tube, Dow Corning® RTV or comparable
- Plumber's sealing putty (Champion P/N 104889) or comparable
- Pipe thread sealant, Loctite® 565 or comparable

If you disassembled your dishwasher to move it through hatches as described in Part 2.2, then follow the instructions in this part to reassemble your dishwasher. Go to Part 2.4, Permanent Placement, if disassembly was not required for your dishwasher.

Perform the following steps to reassemble the dishwasher prior to permanent placement. Refer to Fig. 2.1 on the preceding page.

1. Before moving the sections into position, inspect the location site to ensure the electrical, plumbing, and ventilation services are provided in the correct locations. Compare the site connections with the dishwasher to ensure they will match when the machine is set in its permanent location.
2. Move the wash and rinse tanks in close proximity to each other in the direction they will be installed.
3. Apply a 1/2" bead of silicone sealant on the face of all sides of the wash tank hood gasket.
4. Move the rinse tank closer to the wash tank and check the alignment of the bolt holes at the base and around the tank hood.
5. Adjust the rinse tank adjustable legs to align the bolt holes.
6. **BOLT THE HOOD SECTIONS FIRST.**
Make sure the U-clip removed in Step 8, Part 2.2 is installed.
Start the bolts and tighten nuts hand tight.
7. Check the alignment of the 1-1/2" drain union underneath the machine. Adjust tanks as required.
8. Start the bolts and hand tighten the nuts to join the bases.
9. Connect the 1-1/2" drain union.
10. Tighten all bolts securely using a cross pattern to pull the tanks together evenly.
11. Reconnect the wiring and plumbing. Refer to Steps 12-14, Part 2.2 and Fig 2.1.
12. Pull the conveyor drive chains stored in the wash tank back to the rinse tank. Make sure the drive chain with the dishrack lugs is positioned on the rear track. See Item 7, Fig.2.1.
13. Replace the drive chain master links and tighten the chain adjusters evenly. Proper chain tension is achieved when the chain can be lifted off the track a maximum of 1-1/2".
14. Reinstall remaining plumbing using plumber's putty or thread sealant where required. Refer to Steps 2-5, Part 2.2 and Fig.2.1
15. Position dishwasher in its permanent location.
16. Lift the dishwasher and replace the adjustable legs with the flanged mounting feet provided.
17. Level the dishwasher front to back and side to side by turning the adjustable feet. Make sure the load and unload openings align with the table system height.
18. Reinstall the vent collars.
19. Go to Part 2.4, Permanent Placement.

2.4 Permanent Placement

Refer to Part 2.2, Disassembly and Part 2.3, Reassembly if your dishwasher requires transport through ship hatches, otherwise proceed with the instructions listed below.

Perform the following steps to place the dishwasher in its permanent location.

1. Before moving the sections into position, inspect the location site to ensure the electrical, plumbing, and ventilation services are provided in the correct locations. Compare the site connections with the dishwasher to ensure they will match when the machine is set in its permanent location.



CAUTION:

Check piping mounted underneath dishwasher before lifting, to avoid damaging the machine.

2. Lift the dishwasher and replace the adjustable legs with the flanged mounting feet provided.
3. Position dishwasher in its permanent location.
4. Level the dishwasher front to back and side to side by turning the adjustable feet. Make sure the load and unload openings align with the table system height.
5. Position the external booster heater at the unload end of the dishwasher. Check alignment of common plumbing connections between booster and dishwasher.
6. Install deck plates, and bolt dishwasher and booster to deck per standard procedures.

2.5 Connections between the dishwasher and booster

Refer to Figure 2.2 on the next page.



WARNING:

The installation of this unit must conform to local codes or, in the absence of local codes, to the National Electrical Code and all National Codes governing plumbing, sanitation, safety and good trade practices.

Connect the plumbing and electrical connections between the dishwasher and booster heater.

1. Connect the 1/2" condensate union from the dishwasher to the booster. (See No. 1, Fig. 2.2).
2. Connect the 3/4" steam union from the dishwasher to the booster. (See No. 2, Fig. 2.2).
3. Connect the 3/4" water line from the booster to the top of the dishwasher at the vacuum breaker. (See No. 3, Fig. 2.2).
4. Pull the electrical conduit and harness from the junction box located on the lower rear corner of the dishwasher to the booster junction box located on the lower left rear leg of the booster stand. (See No. 1, Fig. 2.2).
5. Match the harness wire numbers to the booster junction box wiring.

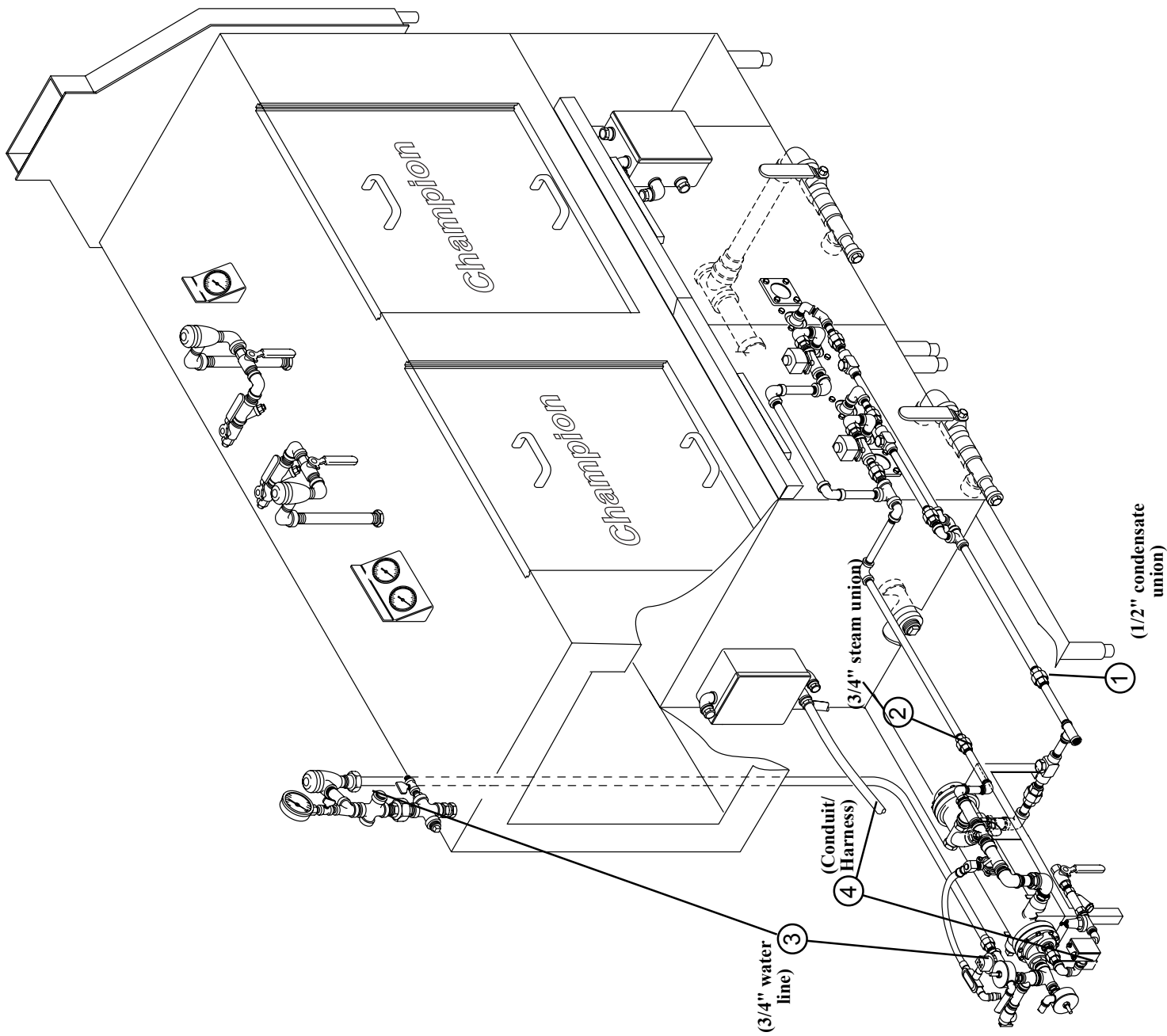

Figure 2.2
Connections Between
Dishwasher and Steam Booster
(Right to left model shown)

2.6 Water Connections

Perform the following steps to connect the water supply
Refer to Figure 2.3 on the next page.



WARNING:

The installation of water supplies must conform to local codes or, in the absence of local code, all National Codes governing plumbing, sanitation, safety and good trade practices.

1. Connect a 3/4" NPT hot water supply line (110°F minimum) to the water inlet valve located at the booster. (See No. 1, Fig. 2.3.)
2. Connect a 1/2" NPT hot water line (140°F minimum) to the water inlet valve located at the top of the dishwasher. (See No. 2, Fig. 2.3.)

2.7 Steam and Condensate Connections (Steam heat only)

Perform the following steps to connect the steam supply and condensate return.
Refer to Figure 2.3 on the next page.



WARNING:

The installation of steam supplies must conform to local codes or, in the absence of local code, all National Codes governing plumbing, sanitation, safety and good trade practices.



NOTE:

A manual shut-off valve for steam (supplied by others) should be installed in the supply lines to allow for servicing of the machine. The shut-off valve should be the same size or larger than the supply line.

1. Connect a 1-1/2" NPT steam supply line to the line strainer located at the booster. (See No. 3, Fig 2.3)
2. Connect a 1" NPT steam condensate line to the tee fitting located at the booster. Condensate must be gravity return to the boiler or to a pumping trap. (See No. 4, Fig. 2.3)

Utility Connection Points

No.	Description
1	3/4" NPT hot water supply line for booster
2	1/2" NPT hot water supply line for dishwasher
3	1/2" NPT steam supply line
4	1/2" NPT steam condensate line
5	1-1/2" NPT drain line
6	1/2" NPT vent collar drain line
7	Dishwasher main electrical junction box prior to S/N JXXXX
7A	Wash/Rinse tank electrical junction box after S/N JXXXX
8	11.13" x 3.87" vent collar connection
9	1/4" rinse aid injection point
10	Detergent injection point

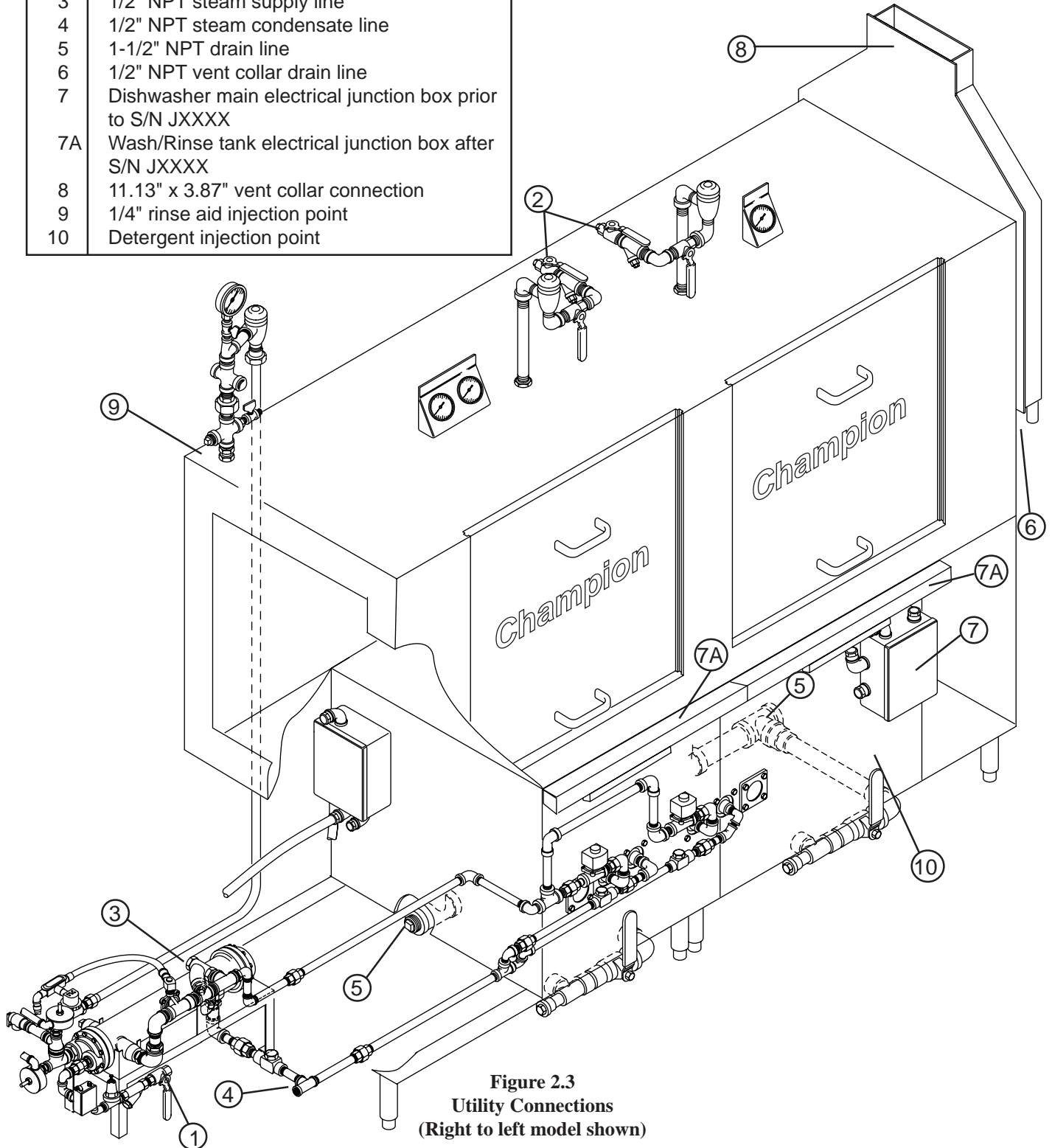

Figure 2.3
Utility Connections
 (Right to left model shown)

2.8 Drain Connections

Perform the following steps to connect the drain lines.
Refer to Figure 2.3 on the preceding page.



WARNING:

The installation of drains must conform to local codes or, in the absence of local code, all National Codes governing plumbing, sanitation, safety and good trade practices.

1. Connect a 1-1/2" NPT drain line to the dishwasher. The machine drain is a level line so connection can be made on either end by relocating the drain plug. The drain line is located underneath the dishwasher. (See No. 5, Fig. 2.3, page 11.)
2. Connect 1/2" NPT drain lines to the load and unload vent collars, (2) connections per collar. (See No. 6, Fig. 2.3, page 11.)

2.9 Ventilation Connections

Perform the following steps to connect the ventilation system
Refer to Figure 2.3 on the preceding page.



WARNING:

The installation of ventilation must conform to local codes or, in the absence of local code, all National Codes governing plumbing, sanitation, safety and good trade practices.

1. Connect an exhaust duct to the load and unload vent collar located at each end of the dishwasher. Inside dimensions of the vent collar connection are 11.13" x 3.87". (See No. 8, Fig. 2.3, page 11).
2. The minimum vent capacities are given below:

Load end	200 CFM @ 1/4"S.P. (minimum)
Unload end	400 CFM @ 1/4"S.P. (minimum)

2.10 Electrical Connections

Perform the following steps to connect the electrical supply.
Refer to Figure 2.3, page 11 and Figure 2.6, page 17.



WARNING:

The installation of electrical supplies and controls must conform to local codes or, in the absence of local codes, the National Electrical Code and good trade practices.



WARNING:

*Dangerous voltages are present at the local electrical distribution system.
Dangerous voltages are present at the dishwasher when it is connected to the local electrical distribution system.*



WARNING:

When working on the dishwasher, disconnect the electric service and place a red tag at the disconnect switch to indicate work is being done on that circuit.

1. A qualified electrician must compare the electrical power supply with the machine electrical specifications stamped on the MACHINE ELECTRICAL CONNECTION PLATE located inside the remote control cabinet (see No. 1, Fig 2.6, page 17) before connecting to the incoming service through a fused disconnect switch.
2. Refer to Figure 2.3, No. 7 and 7A (depending on serial number), on page 11. No. 7 indicates the location of the wash tank junction box for the right to left machine. The box is located on the opposite end of the dishwasher for a left to right machine. No. 7A indicates the location of the wash and rinse tank junction box.



NOTE:

Mounting hardware, conduit, and electrical wiring to connect the remote control cabinet to the local electrical distribution system are supplied by others. Hardware, conduit, and electrical wiring to connect the remote control cabinet to the dishwasher are supplied by others.

3. Install the dishwasher remote control cabinet on a bulkhead adjacent to the dishwasher. Controls must be easily accessible to the operator.

Refer to Figure 2.6 on page 17.

4. Install the power supply wires from the local distribution panel to the remote control cabinet at the incoming power terminal block. (See No. 2, Fig. 2.6.)
5. For serial numbers prior to J1871, install the power and control wiring between the remote control cabinet and the main electrical junction box located on the front of the dishwasher. Wire numbers are marked on the main terminal board in the remote control cabinet. (See No. 3, Fig. 2.6 page 17.). Terminal board wire numbers correspond to wires marked in the dishwasher main junction box. Match wire numbers and connect.

For Serial numbers after J1872 install the power for the motors and control wiring between the remote control cabinet and the electrical junction boxes located on the front of the dishwasher. Wire numbers are marked on the main terminal strip in the remote control cabinet (see the Interconnection Diagrams in the back of manual). Terminal strip wire numbers correspond to wires marked on the terminal strips in the wash and rinse tank junction boxes. Match wire numbers and connect.

6. Refer to Part 3.3, Start-up Procedure, to test the installation.

2.11 Electrical Tank Heat Connections (Electric heat only)

Perform the following steps to connect the incoming electrical power to the tank heat circuits in the remote control cabinet.

Refer to Fig. 2.4 below, and Fig. 2.5, page 15.



WARNING:

The installation of electrical supplies and controls must conform to local codes or, in the absence of local codes, the National Electrical Code and good trade practices.



WARNING:

Dangerous voltages are present at the local electrical distribution system. Dangerous voltages are present at the dishwasher when it is connected to the local electrical distribution system.



WARNING:

When working on the dishwasher, disconnect the electric service and place a red tag at the disconnect switch to indicate work is being done on that circuit.

1. Connect the incoming 440V/60/3PH power supply to the heat contactor marked for the wash tank heater circuit. Refer to Part 1.5, Electrical Power Requirements, page 4, for full load amp ratings.
2. Connect the incoming 440V/60/3PH power supply to the heat contactor marked for the wash tank heater circuit. Refer to Part 1.5, Electrical Power Requirements, page 4, for full load amp ratings.
3. Item A, Figure 2.5, page 15, illustrates the incoming power connections to the remote control cabinet. Connections are shown entering the top of the cabinet, but the installer may choose to route connections to a different location if necessary.
4. Items B and C, Figure 2.5, page 15, illustrate the conduit routing from the remote control cabinet to the tank heater junction boxes located on the front of the dishwasher.
5. Beginning with serial number J1872, connect the tank heater to the terminal block as shown in in the Interconnection Drawings located on page xxx in the back of the manual.

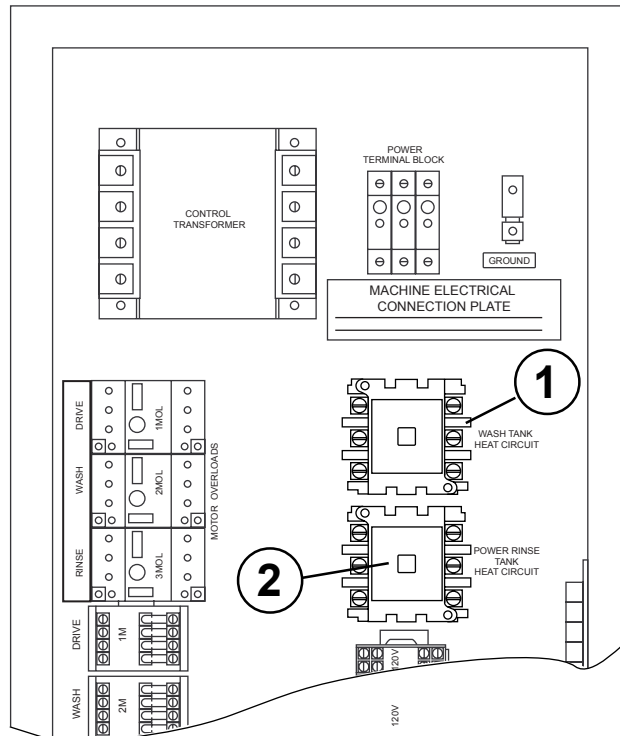

Figure 2.4
Remote Control Cabinet
Incoming Power Connections
for Tank Heat Circuit

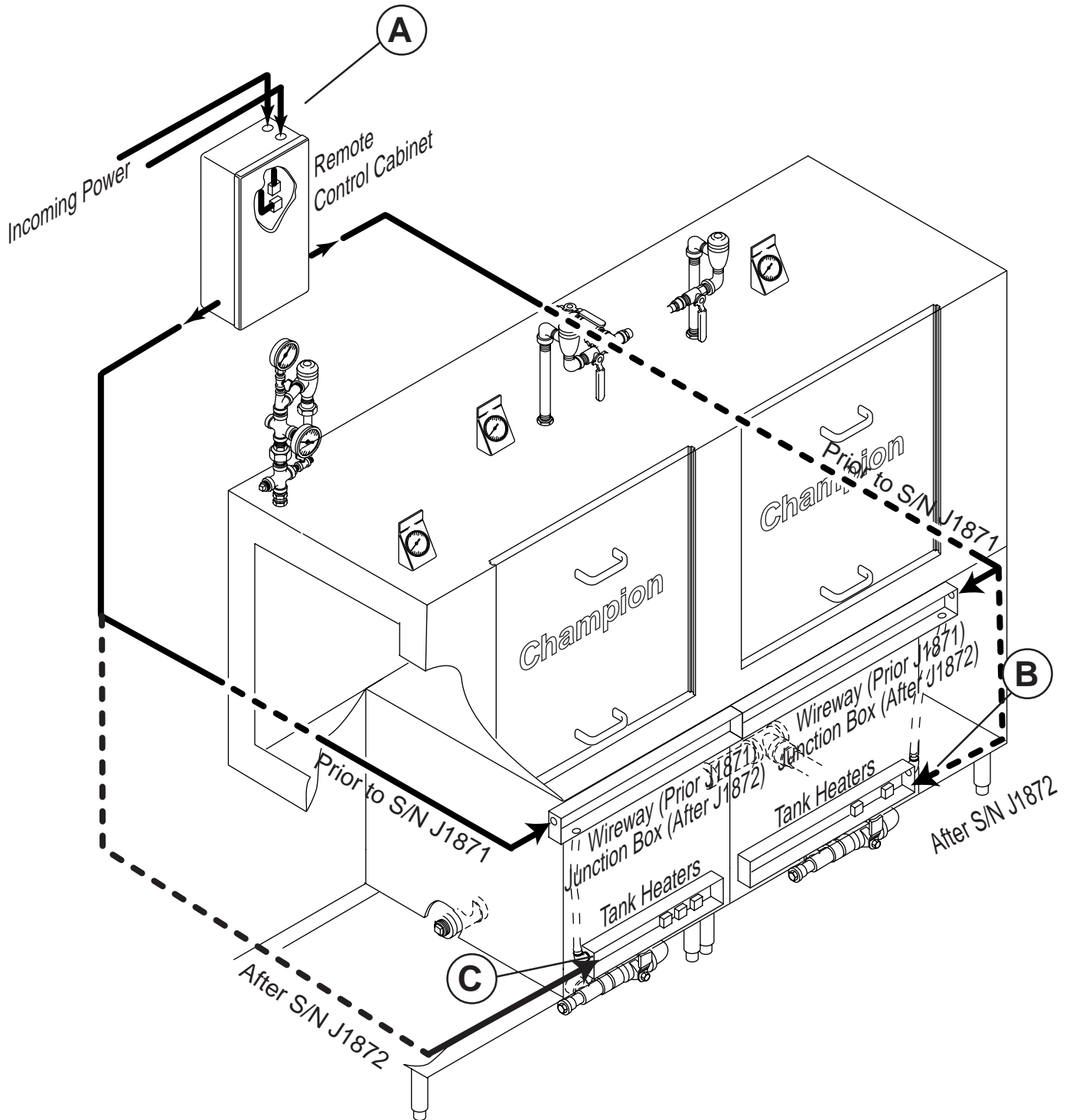

Figure 2.5
 Tank Heater Conduit Routing
 (Right to left model shown)

2.12 Chemical Connections

Perform the following steps to connect the chemical dispensing equipment (if machine is purchased with this feature).

Refer to Figure 2.3, page 11, and Figure 2.6, page 17.



WARNING:

The installation of electrical supplies and controls must conform to local codes or, in the absence of local codes, the National Electrical Code and good trade practices.



WARNING:

*Dangerous voltages are present at the local electrical distribution system.
Dangerous voltages are present at the dishwasher when it is connected to the local electrical distribution system.*



WARNING:

When working on the dishwasher, disconnect the electric service and place a red tag at the disconnect switch to indicate work is being done on that circuit.

1. Chemical dispensing signal connection points are provided on the main terminal board in the remote control cabinet. (See No. 4, Fig. 2.6, page 17.) Beginning with serial number J1872, these same connection points are also located in the wash tank junction box (No. 7 A, Fig 2.6 page 11). Either connection location can be used. A yellow label indicates the connection points.
2. The detergent signal is limited to a maximum load of 1 Amp. Signal voltage is 120VAC.
3. The rinse aid signal is limited to a maximum load of 1 Amp. Signal voltage is 120VAC.
4. Sanitizer is not required for the USN-72 dishwasher.
5. The rinse aid injection point is located in the upper final rinse piping of the dishwasher. (See No. 9, Fig. 2.3, page 11.)
6. The chemical equipment installer must cut a hole in the wash tank for a detergent sensor and a detergent injection point. (See No. 10, Fig. 2.3, page 11.)

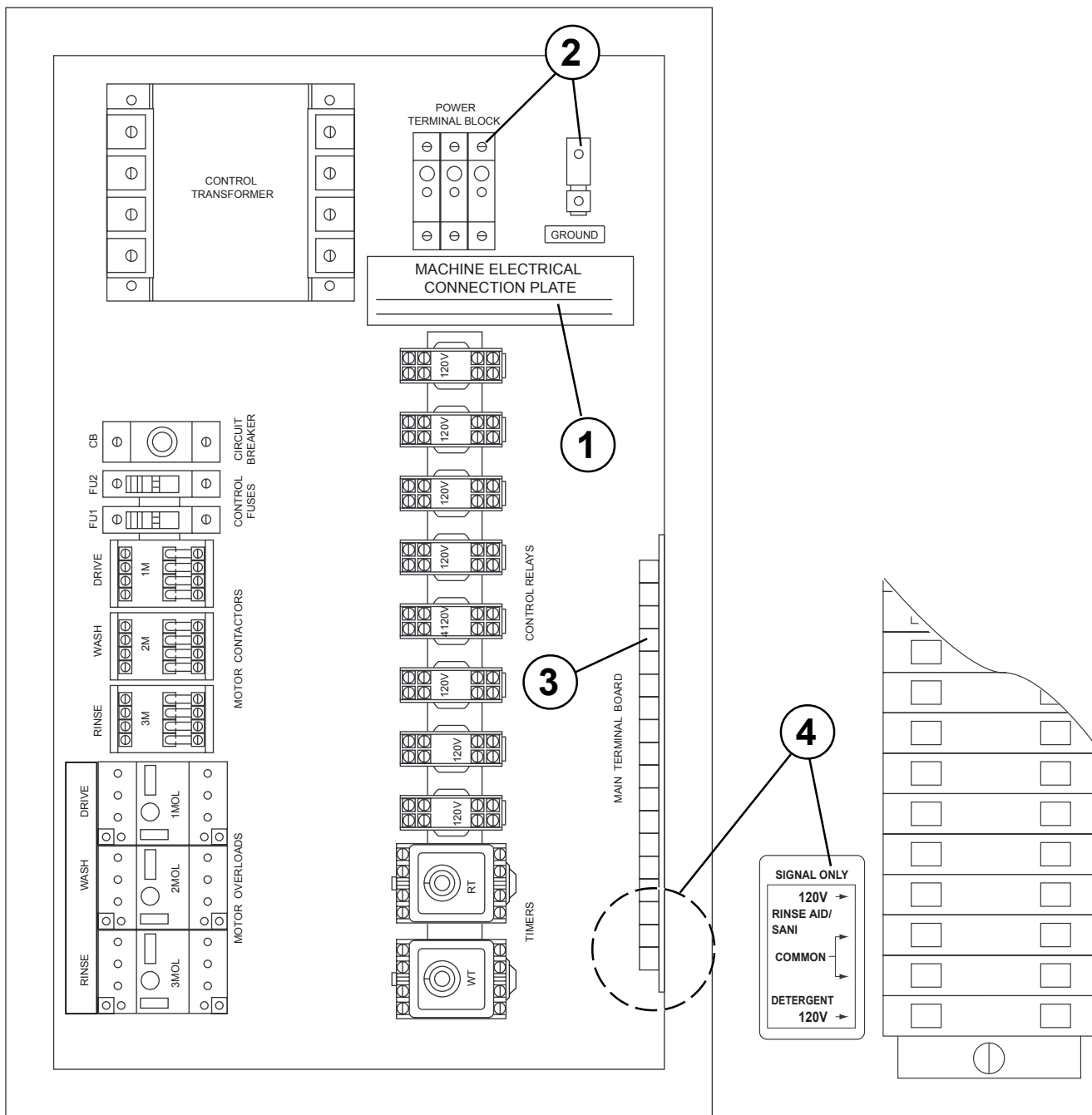

Figure 2.6
Remote Control Cabinet
(Interior View)

**THIS PAGE
INTENTIONALLY
LEFT BLANK**

PART 3: OPERATION

In This Part—

- Theory of operation
- Description of operator controls
- Start up procedure
- Safety and operation checks
- Shutdown procedure
- Operation summary

3.1 Theory of Operation

Dishwashing requires five components to be effective: time, temperature, mechanical action, chemical action and proper procedure. Time allows everything to work. Temperature produced by the heat system is required to heat water in order to penetrate and loosen food soils. Mechanical action produced by the pump system creates water pressure to flush food soils from wares. Chemical action in the form of detergents break down grease and dissolve food particles. Proper procedures in the form of prescraping, prerinsing, and proper loading maximize dishwasher performance.

The USN-72 series dishwasher consists of the wash tank and the power rinse tank. The power rinse tank contains the final rinse piping. Each tank is equipped with its own spray system and a water holding tank. Recirculating pumps draw water from the tanks and direct the water under pressure through the spray system and onto the dishes.

Wash and power rinse water is heated in the tanks by a steam coil or electric tank heater. The final rinse water for sanitizing is heated in an external steam or electric booster heater.

A rack conveyor system made up of dual chains and driven by a conveyor motor and gearbox moves dishracks loaded with wares through the tanks. The wash tank water, which is heated to a minimum of 150°F., contains detergents. Wares are conveyed to the wash tank where they are sprayed with the detergent solution. Food particles and other soils are flushed from the wares and are collected in scrap screens above the water holding tank. Wares continue on the conveyor system to the power rinse tank which is heated to a minimum of 160°F. The power rinse tank spray system rinses remaining soils and soapy water from the wares.

The final stage of the washing operation occurs in the final rinse section. Upper and lower final rinse spray pipes are located at the exit end of the dishwasher. As the dishrack containing wares approaches the final rinse area, the dishrack operates a final rinse switch. The switch activates the final rinse system. Final rinse water, heated to a minimum of 180°F., is forced by water line pressure from the final rinse booster heater. Water sprays from the upper and lower final rinse piping on the wares to sanitize them. The wares are conveyed out the exit end of the dishwasher where operators remove and stack the wares for the next meal period.

The USN-72 is equipped with several safety features. Door safety switches prevent the unit from running if a door is open. A conveyor limit switch stops the dishwasher operation if the conveyor becomes jammed. A float switch located in each tank stops the unit if the water level falls below a preset level. Finally, a low temperature sensor stops machine operation if the final rinse water falls below 180°F.

3.2 Description of Operator Controls and Indicators

3.2.1 Remote Control Cabinet

Refer to Figure 3.1 and Table 3.1 below for the location and function of the operator controls and indicators on the remote control cabinet.

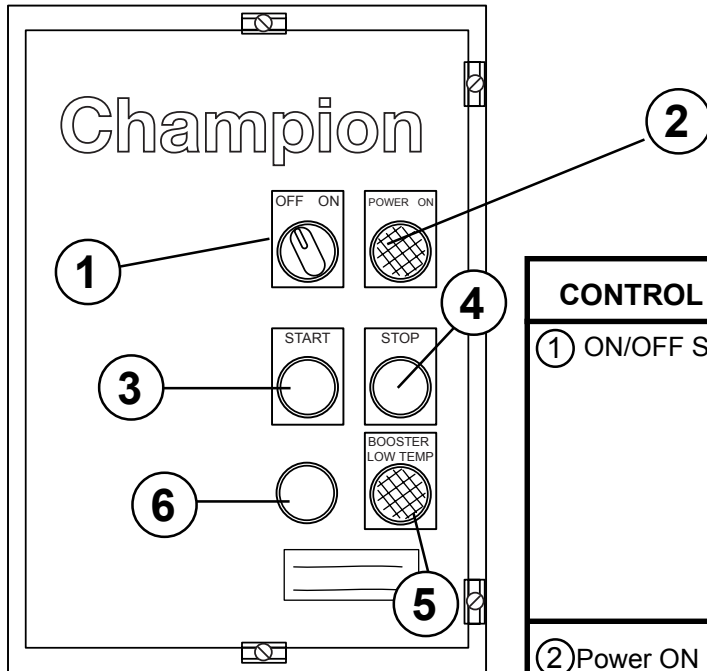

Figure 3.1
Operator Controls
Remote Control Cabinet
(Front Exterior View)

CONTROL	TYPE	FUNCTION
① ON/OFF Switch	Selector	Controls power to the dishwasher. Connects power to tank and booster heat circuits, pump contactors, and drive contactor.
② Power ON light	Red pilot	Signals control power connected to unit if ON/OFF selector ON.
③ Start switch	Green Pushbutton	Starts pumps and conveyor motors.
④ Stop switch	Red pushbutton	Stops pumps and conveyor motors.
⑤ Booster low temperature light	Red pilot light	Indicates final rinse temperature has fallen below 180°F. Dishwasher stops.
⑥ Final rinse water prime button	Green pushbutton	Prime final rinse water temperature to reach 180°F and above when the above function has indicated booster low temperature.

Table 3.1
Controls and Indicators
Remote Control Cabinet

3.2.2 Dishwasher and Booster

Refer to Figure 3.2 below and Table 3.2, page 22 for the location and function of the dishwasher and steam booster operator controls and indicators.

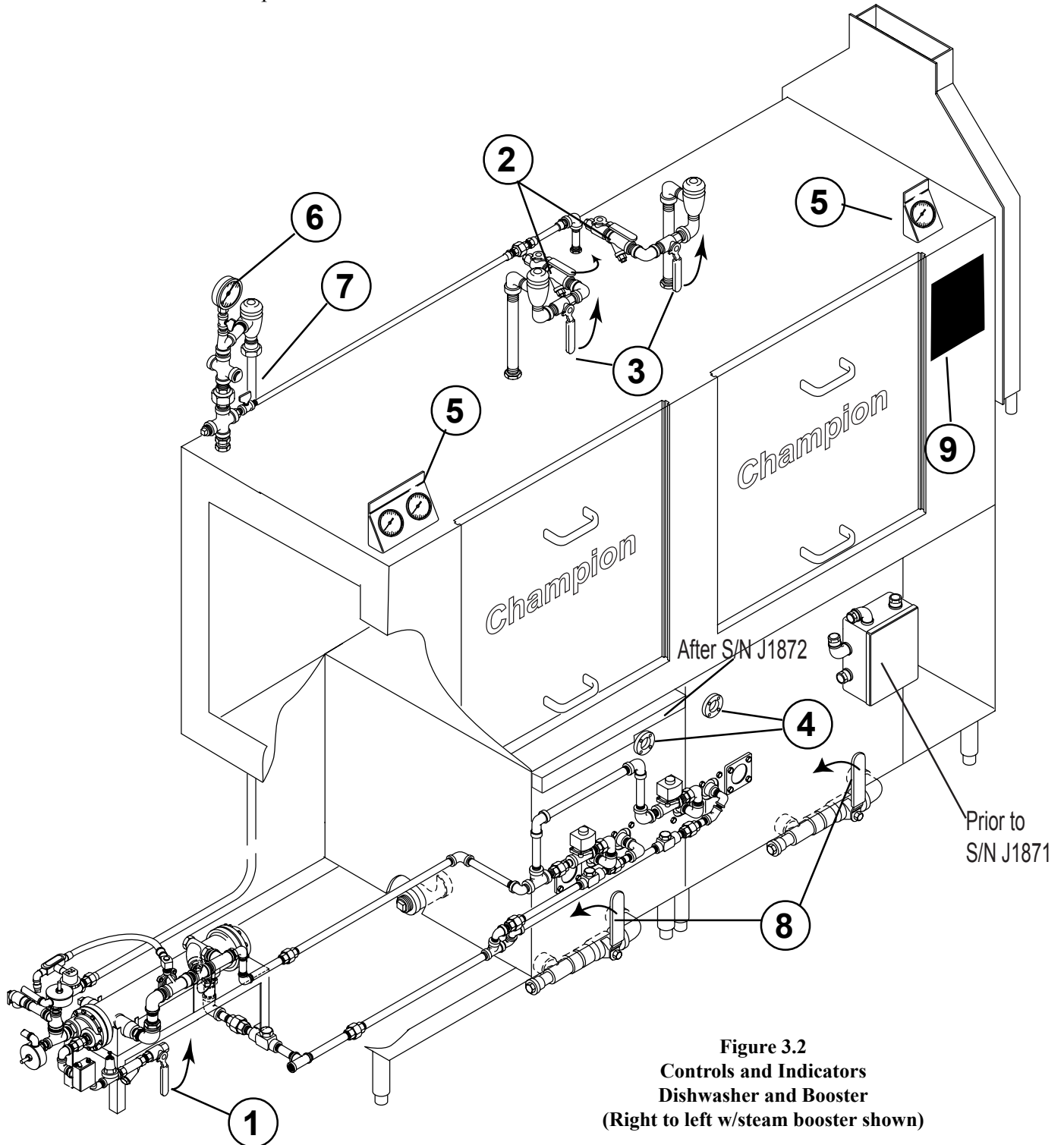

Figure 3.2
Controls and Indicators
Dishwasher and Booster
(Right to left w/steam booster shown)

3.2 Description of Operator Controls and Indicators (Cont.)

CONTROL	TYPE	FUNCTION
① Inlet water supply valve	Ball valve (shown closed)	Connects incoming water supply for the booster.
② Inlet water supply valve	Ball valve (shown open)	Connects incoming water supply for the tank fills.
③ Inlet water supply valves	Ball valves (shown closed)	Controls manual fill to wash tank. Controls manual fill to rinse tank.
④ Water level gauges	Sight glass	Indicates water level in wash and rinse tank. Water line visible in center of glass indicates correct water level in tank.
⑤ Tank water temperature gauges	Scaled thermometer dial	Indicates water temperature in wash and rinse tanks. Wash = 150°F minimum. Rinse = 160°F minimum.
⑥ Final rinse pressure gauge	0-60 PSI gauge	Indicates final rinse water pressure during the final rinse. 20-22 PSIG minimum flow pressure.
⑦ Final rinse temperature gauge	Scaled thermometer dial	Indicates final rinse temperature during the final rinse. 180-195°F optimum range.
⑧ Drain valves	Ball valves (shown closed)	Controls draining of wash and rinse tanks.
⑨ Operation guide	Placard	Complete operation guide to machine (located on load end of machine on front panel under wash gauge next to wash door)

Table 3.2
Controls and Indicators
Dishwasher and Booster

3.3 Start-Up Procedure

Perform the following steps to start up the dishwasher for first-time operation.

**CAUTION:**

Perform the following checks before placing the machine into service.

1. Check the exterior of the machine for any foreign material, and remove.

**NOTE:**

*To remove the dishwasher lift-out doors:
Grasp the handles and lift approximately 4".
Tilt the top of the door toward you and out of the door track.*

2. Remove the lift-out doors.
3. Check the interior of the machine and remove any foreign material.

**NOTE:**

*To install the upper and lower spray pipes:
Insert the pipe into its locking plate and turn 1/4 turn clockwise.
Each pipe has an o-ring on the end of its manifold.*

4. Make sure the upper and lower spray arms are secure in the manifold and all end plugs are in place.
5. Remove the scrap screens and make sure all overflow covers are down and the pump intake screens are in place.
6. Replace the scrap screens.

**NOTE:**

*Dishwasher curtains have long and short flaps.
Be sure the short flaps of all curtains face the load end of the machine.
Place long curtains at the load and unload ends of the dishwasher.
Place the short curtain at the end of the wash tank in the center of the dishwasher.*

7. Make sure the curtains are in place.
8. Reinstall the lift-out doors.
9. Check the chemical injection system (if applicable).
10. Close the tank drain valves along the lower front of the machine.
11. Open the water supply valves. Check for leaks and take corrective action if required.

12. Open the steam supply valves (if applicable).
Check for leaks and take corrective action if required.
13. Open the manual tank fill valves on the top of dishwasher to fill the tanks.
14. Monitor the water level gauges.
Tanks are full when the water line reaches the center of the gauges.
15. Close the manual fill valves and check the dishwasher for leaks.
16. Turn the main power on at the breaker panel or fused disconnect switch for the dishwasher.
17. Turn the main power on at the breaker panel or fused disconnect switch for the electric booster heater (if applicable).
18. Turn the power selector switch on the front of the remote control cabinet to the “ON” position. The red power-on light will illuminate.



NOTE:

*Allow sufficient time for the tanks to reach proper temperatures (approx. 20 minutes):
Wash tank temperature = 150°F. minimum.
Power rinse tank temperature = 160°F. minimum.*

19. Monitor the tank thermometers located on the top of the dishwasher for the proper temperature reading. The wash and rinse tank thermometers are located on the lower front of the tank assembly for machines beginning with S/N J08122570.
20. Press the GREEN start button on the front of the remote control cabinet.
Pumps and conveyor start.
21. Check the direction of rotation of the conveyor drive.
Conveyor drive sprocket (located behind stainless steel cover on unload end) turns CCW for right to left operation, CW for left to right operation.
22. Check the direction of rotation of the pump motors.
Proper rotation is CW when viewing the motor from the rear.



WARNING:

*Dangerous voltages are present at the local electrical distribution system.
Dangerous voltages are present at the dishwasher when it is connected to the local electrical distribution system.*



WARNING:

When working on the dishwasher, disconnect the electric service and place a red tag at the disconnect switch to indicate work is being done on that circuit.

23. If the rotation direction is incorrect, reverse wires L1 and L2 on the disconnect switch side of the main electrical connection terminal block located inside the remote control cabinet.
24. Press the RED stop button. The red power light goes out, and the pumps and conveyor stop. Press the GREEN start button. The red light comes on; the pumps and conveyor run.
25. Proceed to Part 3.4, Safety and Operation Checks, on next page.

3.4 Safety and Operation Checks

Refer to Part 3.3, Start-up Procedure, on the previous page before performing the steps listed below.

Perform the following steps to check the dishwasher safety devices and to operate the dishwasher for the first time.

Safety Checks



WARNING:

Perform the following checks before placing the machine into service for normal operation.



WARNING:

Never bypass a safety device in order to operate the dishwasher for normal operation.



NOTE:

Refer to the corresponding repair or adjustment procedure in Part 5, Basic Service, if a safety device fails to function in the manner prescribed below.

Dishwasher Condition

The dishwasher is full of water, steam or electric heat energized, and dishwasher power is on. Temperature gauges indicate proper temperatures. The pumps and conveyor are running.

Door Safety Switch Check

1. Slowly raise the wash tank lift-out door approximately 1 inch. Dishwasher pumps and conveyor stop.
2. Lower wash tank door. Press green start button. Pumps and conveyor run.
3. Slowly raise the power rinse tank lift-out door approximately 1 inch. Dishwasher pumps and conveyor stop.
4. Lower power rinse tank door. Press green start button. Pumps and conveyor run.

Table Limit Switch Check (if applicable)

1. Slide empty dishrack on unload table system until it contacts the installed table limit switch. Dishwasher pumps and conveyor stop.
2. Remove the dishrack. Press green start button. Pumps and conveyor run.

Low Water Tank Heat Protection Check

1. Open the drain valve on the wash tank.
2. Pumps and conveyor stop when the water level falls below the level of the wash tank float switch.
3. Close the drain valve.
4. Open the manual fill valve and refill the wash tank.
5. Push the green start button on the control cabinet.
Pumps and conveyor run.
6. Repeat Steps 1-5 for the power rinse tank.

Conveyor Jam Switch Check Refer to Figure 3.3 below



WARNING:

*The conveyor drive contains moving parts.
Use caution when working around the conveyor drive assembly.*

1. Using a hydraulic jack or lever, raise the conveyor drive table (A) approximately 2 inches to simulate a jam condition.
2. The conveyor jam switch (B) operates.
3. Pumps and conveyor stop.
4. Lower the conveyor drive table.
5. Push the green start button on the control cabinet.
Pumps and conveyor run.

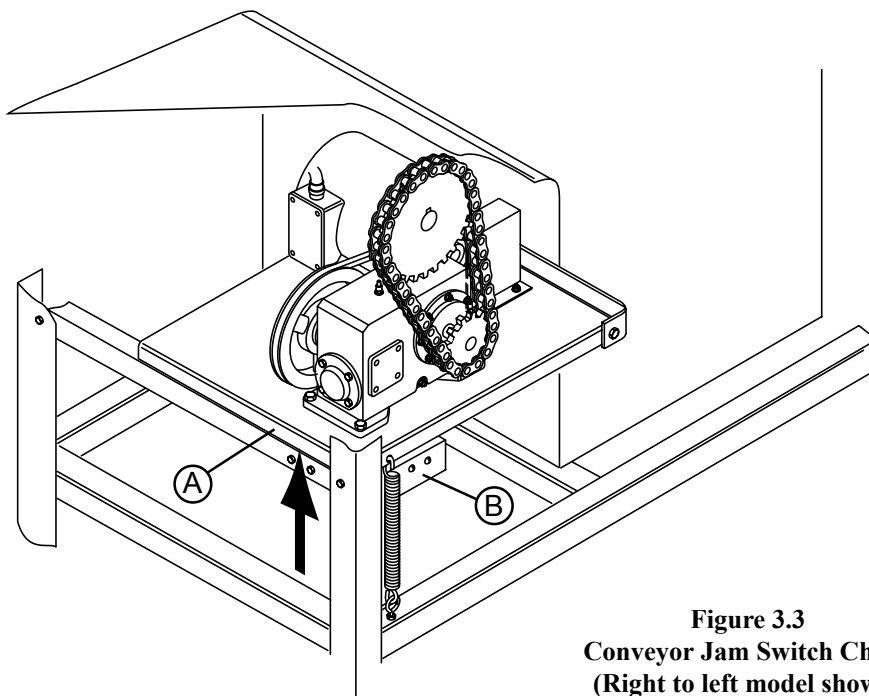

Figure 3.3
Conveyor Jam Switch Check
(Right to left model shown)

3.4 Safety and Operation Checks (Cont.)

Perform the following steps to check the dishwasher safety devices and to operate the dishwasher for the first time.

Safety Checks (Cont.)

**WARNING:**

Perform the following checks before placing the machine into service for normal operation.

**WARNING:**

Never bypass a safety device in order to operate the dishwasher for normal operation.

**NOTE:**

Refer to the corresponding repair or adjustment procedure in Part 5, Basic Service, if a safety device fails to function in the manner prescribed below.

Dishwasher Condition

The dishwasher is full of water, steam or electric heat energized, and dishwasher power is on. Temperature gauges indicate proper temperatures. The pumps and conveyor are running.

Booster Low Temperature Check

1. Insert several racks into the machine to operate the final rinse.
2. Monitor the final rinse temperature gauge located on the top of the dishwasher in the upper final rinse piping. Minimum temperature required is 180°F.
3. Close the steam supply valve to the dishwasher so the booster will not heat the final rinse water.
4. Continue to feed racks into the machine.
5. When the final rinse water temperature at the booster falls below 180°F. the pumps and conveyor stop.
6. The booster low temperature light on the remote control cabinet illuminates.
7. Open the steam supply valve to the dishwasher.
8. PUSH and HOLD the green start button until the booster low temp light goes out.
9. Release the green start button.
10. Pumps and conveyor continue to run.

Operation Checks

Refer to Part 3.3, Start-up Procedure, on pages 20-21 before performing the steps listed below.

Perform the following steps to check the dishwasher operation for the first time.

Operation Checks

Dishwasher Condition

The dishwasher is full of water, steam or electric heat energized, and dishwasher power is on. Temperature gauges indicate proper temperatures. The pumps and conveyor are running.

1. Prescrap and prerinse wares to remove large food particles.
Hard baked-on soils may require soaking or scrubbing.
2. Load a dishrack with soiled wares.
Place dishes edgewise in a peg rack.
Place cups and bowls upside down in a flat bottom rack.
Spread silverware evenly in a single layer in a flat bottom rack.
3. Do not overload dishracks.
4. Slide the rack into the load end of the dishwasher.
The conveyor advances the rack through the dishwasher.
5. Monitor the wash temperature gauges.
Wash tank temperature must maintain 150°F. minimum.
Power rinse tank must maintain 160°F. minimum.
6. Monitor the final rinse temperature gauge as the dishrack moves into the final rinse area. Minimum temperature required is 180-195 °F.
7. Monitor the final rinse pressure during the final rinse. Minimum final rinse FLOWING pressure must be 20-22 psig. The pressure gauge may indicate a higher rinse pressure after the final rinse water stops flowing. This is a normal condition.



WARNING:

Dishwasher surfaces, dishracks and wares become hot during and immediately after washing operations. Wear protective gear per your supervisor's directions.

8. Slide the dishrack to the table system as it is ejected from the unload end of the dishwasher. Inspect the wares for cleanliness.
9. Adjust chemical dispensing equipment (supplied by others) as required.

3.5 Shutdown Procedure

Perform the following steps to shutdown the dishwasher after every operation.



WARNING:

Dishwasher surfaces, dishracks and wares become hot during and immediately after washing operations. Wear protective gear per your supervisor's directions.

1. Press the red stop button to shut off the pumps and conveyor.
2. Turn the power selector switch on the remote control cabinet to OFF.
The red power light goes out.
3. Turn the power off to the dishwasher at the main service disconnect switch or breaker.
4. Turn the power off to the electric booster (if applicable) at the main service disconnect switch or breaker.
5. Close the steam supply valve (for steam heated dishwashers).
6. Open the wash tank and power rinse tank drain valves.
Valves are located on the lower front of the tanks.
7. Remove the lift-out doors, and rinse inside of doors.
8. Remove curtains to remote sink, and flush clean.
9. Remove the upper and lower spray arms.
Turn arms CCW 1/4 turn. Pull gently.
10. Inspect spray arm o-rings on manifolds. Replace if missing or damaged.
11. Remove end caps from spray arms, and flush arms with water.
12. Replace end caps in spray arms. Set spray arms aside.
13. Flush interior of machine to remove debris on upper hood surfaces.
14. Remove scrap screens from dishwasher interior.
15. Flush both sides of screens in remote sink to remove accumulated debris.
16. Flush interior of lower tanks with fresh water to remove debris.
17. Clean drain screens.
18. Wipe interior of dishwasher including tank bottoms.
19. Remove and clean pump intake screens. Replace immediately after cleaning.
20. Lift overflow covers, and flush water down overflow tubes.
21. Clean float switch assemblies, and check for free movement.
22. Flush steam coils or electric heaters.
Use a nonferrous scrub pad to remove scale from electric heaters (for electric heated dishwashers).
23. Close overflow covers.
24. Replace scrap screens.
25. Replace spray arm assemblies.
26. Replace curtains.
27. Leave doors removed to aid air drying of dishwasher interior.
28. Turn power off to exhaust vents (if applicable).

3.6 Operation Summary

The following summarizes the steps for the normal operation of your dishwasher.

1. Check that spray arms, curtains, scrap screens, and doors are in place. Refer to Figures 3.4 and 3.5 below.
2. Check that detergent and rinse aid reservoirs are replenished. (Dispensing equipment and chemicals are supplied by others.)
3. Check that drains are closed.
4. Turn the power on to the dishwasher at the main service disconnect switch.
5. Turn the power on to the electric booster at the main service disconnect switch (for electric booster only).
6. Open manual tank fill valves. Monitor water level gauges.
7. Close fill valves when water level reaches center of water level gauges.
8. Turn power selector switch at remote control cabinet to ON.
9. Wait for tank water temperatures to reach operating temperature.
Wash tank temperature = 150°F. minimum
Power rinse tank temperature = 160°F. minimum
10. Press GREEN start button on control cabinet. Pumps and conveyor run.
11. Scrap and prerinse wares. Place in dishracks. Do not overload racks.
12. Slide dishrack into load end of dishwasher.
13. Check the final rinse temperature and the final rinse pressure during the final rinse (180°-195°F @ 20-22 psig flow pressure).

NOTE:

The dishwasher may be stopped any time during the cycle by pressing the STOP button on the control cabinet. Press the GREEN start button and all wares inside the dishwasher will be fully washed and rinsed.

14. Refer to Part 4.2, Cleaning Schedule, for daily cleaning instructions.
15. Perform the shutdown procedure described on the preceding page.

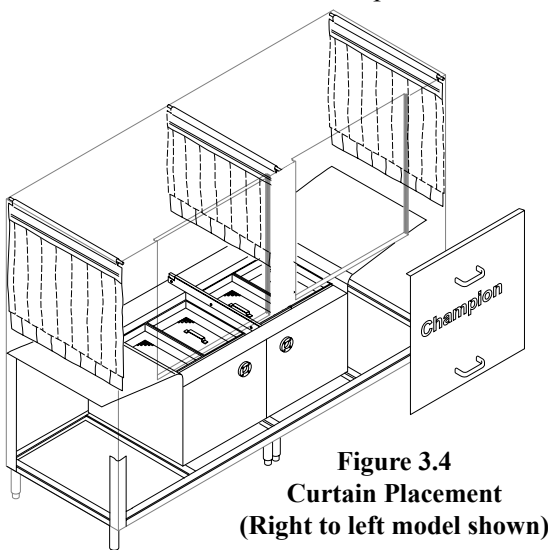

Figure 3.4
Curtain Placement
(Right to left model shown)

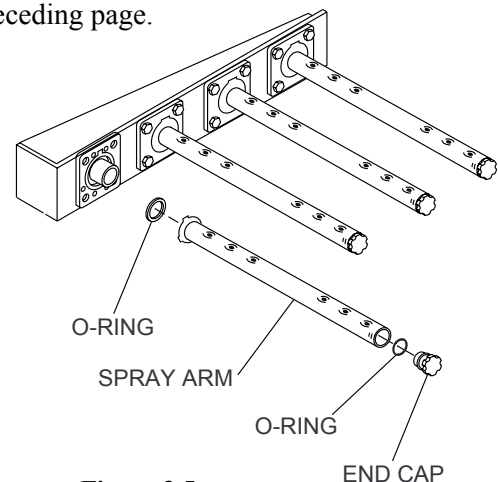

Figure 3.5
Spray Arm Assembly
(Lower manifold shown)

PART 4: CLEANING AND MAINTENANCE

In This Part—

- Introduction
- Daily cleaning schedules
- Delimiting schedules
- Preventive maintenance schedules
- Lubrication schedules

4.1 Introduction

Cleaning your machine is the best maintenance that you can provide. Components that are not regularly flushed and cleaned do not perform well.

The following schedules are the minimum requirements necessary for the proper performance of your machine. Intervals should be shortened whenever your machine is faced with abnormal working conditions, hard water, or multiple shift operations.

4.2 Daily Cleaning Schedules

After Each Meal Period

1. Drain the machine.
2. Flush interior with fresh water.
3. Clean scrap screens and pump intake screens.
4. Clean spray arms.
5. Clean the final rinse nozzle openings with a paper clip.

**CAUTION:**

Do not hose down the exterior of the machine with water.

6. Thoroughly clean the exterior of the machine with a mild soap solution.
7. Reassemble the machine.
8. Leave the doors off to aid in drying.

4.3 Deliming Schedules

Your dishwasher should be delimed regularly depending on the mineral content of your water. Inspect the machine interior for mineral deposits and use a deliming solution for the best cleaning results.



WARNING:

Deliming solutions or other acids must not come in contact with household bleach (sodium hypochlorite) or any chemicals containing chlorine, iodine, bromine, or fluorine.

Mixing will cause hazardous gases to form.

Skin contact with deliming solutions can cause severe irritation and possible chemical burns.



WARNING:

Consult your chemical supplier for an appropriate deliming solution, protective gear and safety procedures.

4.4 Preventive Maintenance Schedules

Weekly Maintenance Requirements

Perform the following procedures every week.

**CAUTION:**

Only qualified service personnel should perform preventive maintenance on the dishwasher

1. Inspect for leaks including all piping, tank seams, and supply connections. Tighten or repair as required.
2. Inspect the lift-out doors for proper fit and ease of removal.
3. Check the operation of door safety switches.
Refer to Part 3.4, Safety and Operation Checks on page 22.

**WARNING:**

When working on the dishwasher, disconnect the electric service and place a red tag at the disconnect switch to indicate work is being done on that circuit.

4. Turn the power selector switch to OFF at the remote control cabinet.
5. Drain the dishwasher if required and inspect the float switches and probes in the bottom of each tank. Float switches should move freely. Clean if necessary.
6. Check the conveyor drive chains, spray arms and internal structures for wear or damage.
7. Reassemble the dishwasher.
8. Turn the power selector switch to ON at the remote control cabinet.
9. Check the operation of the start and stop switches on the control cabinet.
10. Check that the red power indicator works correctly.
11. Return the dishwasher to normal operation.

Quarterly Maintenance Requirements

Perform the following procedures every four months.



CAUTION:

Only qualified service personnel should perform preventive maintenance on the dishwasher.

1. Perform all the procedures described in the weekly maintenance requirements.
2. Refer to Part 3.4, Safety and Operation Checks, and perform all the checks described in this part.
3. Close all water and steam supplies. Run the dishwasher for 2 minutes to relieve water and steam pressure in the lines.
4. Disassemble the water and steam inlet line strainers and clean as necessary.



WARNING:

When working on the dishwasher, disconnect the electric service and place a red tag at the disconnect switch to indicate work is being done on that circuit.

5. Disconnect the power to the dishwasher at the main service disconnect switch. Tag the circuit to indicate work is being performed on that circuit.
6. Disconnect the power to the electric booster (if applicable) at the main service disconnect switch. Tag the circuit to indicate work is being performed on that circuit.
7. Open the control cabinet enclosure(s) and check the tightness of all electrical wiring connections.
8. Inspect all wiring for signs of heat damage, and replace if necessary.
9. Manually operate the contactors and overloads checking for free movement.
10. Close the control cabinet enclosures.
11. Inspect and tighten all mounting hardware. Replace missing or damaged fasteners with stainless steel replacements.
12. Return the dishwasher to normal operation.



NOTE:

Refer to Part 4.5, Lubrication Schedules, on the next page for quarterly lubrication procedures.

4.5 Lubrication Schedules

Weekly Lubrication Requirements

There are no weekly lubrication requirements.

Non-lubrication Requirements

Do not lubricate the points described below.



WARNING:

Do not lubricate the stainless steel conveyor chain or shaft bearings inside the dishwasher wash and power rinse tanks.

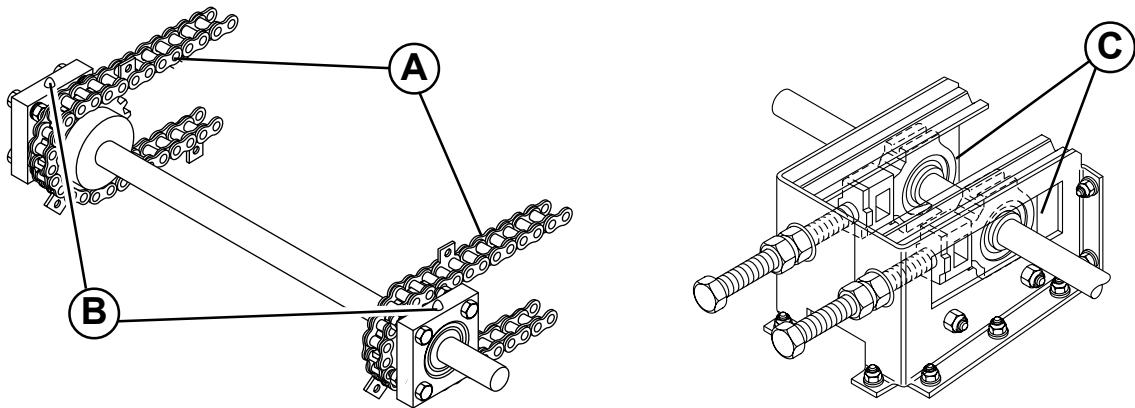

Figure 4.1 ((C) is in machines prior to J1050)
Never Lubricate These Points

Refer to Figure 4.1 above.

1. **NEVER LUBRICATE** the stainless steel conveyor chains (A) located inside the dishwasher.
2. **NEVER LUBRICATE** the drive shaft bearings (B) located inside the dishwasher on each side of the conveyor drive shaft. The grease fittings on the top of each bearing serve to keep out water.
3. **NEVER LUBRICATE** the idle shaft bearings (B) located inside the dishwasher on each side of the conveyor take-up assembly. The grease fittings on the top of each bearing serve to keep out water.

Quarterly Lubrication Requirements

Perform the following procedures every four months.



CAUTION:

Only qualified service personnel should perform preventive maintenance on the dishwasher.



WARNING:

*The conveyor drive contains moving parts.
Use caution when working around the conveyor drive assembly.*



WARNING:

When working on the dishwasher, disconnect the electric service and place a red tag at the disconnect switch to indicate work is being done on that circuit.

Refer to Figure 4.2 below.

1. Turn the power selector switch to OFF at the dishwasher remote control cabinet.
2. Remove the side panel protecting the drive chain located at the unload end of the dishwasher.
3. Apply a thin coat of oil (Browning GL32LT or comparable) to the drive chain (A). Wipe off any excess.
4. Remove the oil level plug (B) from the top of the gearbox.
5. Remove the breather plug (C) from the side of the gearbox.
6. Remove the drain plug (D) from the bottom of the gearbox and drain the oil.
7. Flush the gear case with a light weight (5 or 10W) mineral oil.
8. Replace the drain plug (D) and refill the gearbox with Browning GL32LT or comparable oil.
9. Fill slowly until oil begins to drain from the oil level plug.
10. Allow the oil to settle for a few minutes, top off if required.
11. Replace oil level plug (B) and breather plug (C).
12. Replace side panel.

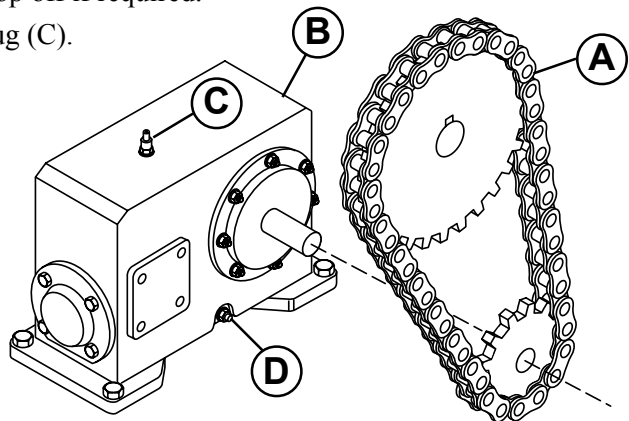

Figure 4.2
Conveyor Gearbox and Drive Chain
Lubrication

PART 5: BASIC SERVICE

In This Part—

- Introduction
- General troubleshooting
- Component adjustment, repair, and replacement

5.1 Introduction

Part 5, Basic Service, covers component adjustment, repair and replacement for the major components of your dishwasher. Use the Troubleshooting Guide (part 5.2 General Troubleshooting) to identify the operating condition of your machine and follow the suggested solution. Some solutions refer to a Repair Procedure 5.3.xx; these solutions should be attempted only by qualified service personnel. If you require additional service support, you may call your local service company or:

The Source
USA: 1-800-497-2144

Please have the Model and Serial Number of the machine ready when you call.

Schematics

Champion places an electrical schematic in the control cabinet of every machine before it is shipped. Schematics are included at the back of this manual as well. Be aware that these schematics include options that may not apply to your machine. Options are enclosed in dashed lines with the words (IF USED) next to them on the schematic. Disregard any options that appear on the schematics which are not a part of your machine.

Electrical Circuit Tests

Use a clip-on AC current tester to check the motors and electric heaters.
Use a VOM to test line voltages and the 120VAC control circuit.



NOTE:

DO NOT USE CHASSIS GROUND WHEN PERFORMING VOLTAGE CHECKS.

Doing so will result in false and inaccurate readings.

PERFORM VOLTAGE CHECKS BY READING FROM THE HOT SIDE OF THE LINE AND NEUTRAL (any #2 or white wire).

Tools

Most repairs can be made with: Standard set of hand tools, Volt/Ohm Meter (VOM), and Clip-on AC current tester. Special tools necessary to perform a repair are noted in the specific repair procedure.

5.2 General Troubleshooting

In the event that your dishwasher does not perform as expected, refer to the troubleshooting guide below. Perform the action suggested in the solution column. Contact a qualified service technician if the solution refers to a Repair Procedure in Part 5.3.

Many conditions may be resolved by performing the seven basic checks listed below:

1. All switches are ON.
2. Drain valves closed.
3. Wash and rinse nozzles are clean.
4. Wash and rinse pipe assemblies are installed correctly.
5. Scrap screens are properly positioned.
6. Thermostat(s) are properly adjusted.
7. Detergent and rinse additive dispensers are adequately filled.

CONDITION	CAUSE	SOLUTION
Machine will not start	Doors not closed	Make sure doors are fully closed
	Main switch off	Check disconnect at main panel Check machine power switch
	Door safety switch faulty	Refer to Repair Procedure 5.3.22
	Conveyor jammed	Refer to Repair Procedure 5.3.20
	Water level low in tank(s)	Check float switch(s) and fill tanks
	Defective float switch	Refer to Repair Procedure 5.3.5
	Motor overload tripped	Refer to Repair Procedure 5.3.24
Low or no water	Blown fuse or circuit breaker	Refer to Repair Procedure 5.3.23
	Main water supply is turned off	Turn on main water supply
	Machine not filled initially	Close drains/Open manual fill valves
	Tank drain valve(s) open	Close drain valve(s)
	Clogged line strainer	Clean strainer screen/replace strainer
Pump motor not running	Faulty manual fill valve	Replace manual fill valve
	Motor overload tripped	Refer to Repair Procedure 5.3.24
Tank(s) water temperature is low when in use	Defective motor	Refer to Repair Procedure 5.3.14
	Incoming water temperature	Raise temperature to: 140°F/43-60°C
	to machine too low	
	Defective thermometer	Refer to Repair Procedure 5.3.7
	Defective thermostat	Refer to Repair Procedure 5.3.8
	Steam supply shut off	Turn on steam supply
	Low steam pressure	Correct steam pressure is 15-30 PSI
Defective steam solenoid valve	Refer to Repair Procedure 5.3.4	
Defective steam trap	Refer to Repair Procedure 5.3.11	

5.2 General Troubleshooting (Cont.)

CONDITION	CAUSE	SOLUTION
Insufficient pumped spray pressure	Clogged pump intake screen	Clean pump intake screen
	Clogged spray pipe	Clean spray pipe
	Scrap screen full of debris	Must be kept clean and in place
	Low water level in tank	Check drain valve(s)
	Pump motor rotation incorrect	Refer to Part 3.3, Start-up Procedure, Steps 21-23, page 24
	Defective pump seal	Refer to Repair Procedure 5.3.14
	Spray pipe end plug missing	Replace missing end plug
	Spray pipe O-ring missing	Replace missing O-ring
	Wash restrictor needs adjustment	Refer to Repair Procedure 5.3.13
Insufficient final rinse or no final rinse	Faulty pressure reducing valve	Refer to Repair Procedure 5.3.1
	Improper setting on pressure reducing valve	Correct pressure setting is 20-22 PSI
	Clogged rinse nozzle and/or pipe	Clean pipe/nozzles
	Clogged line strainer	Clean screen or replace line strainer
	Defective final rinse switch	Refer to Repair Procedure 5.3.15
	Defective final rinse solenoid valve	Refer to Repair Procedure 5.3.4
Low final rinse temperature	Low incoming water temperature	Increase incoming water temperature 110°F minimum for 70°rise booster 140°F minimum for 40°rise booster
	Booster steam supply shut off	Turn on steam supply
	Booster water supply shut off	Turn on water supply
	Rinse nozzle or pipe cap missing	Replace missing part
	Defective final rinse thermostat	Refer to Repair Procedure 5.3.9
	Defective thermometer	Refer to Repair Procedure 5.3.7
	Low steam pressure	Correct steam pressure is 15-30 PSI
	Defective steam solenoid valve	Refer to Repair Procedure 5.3.4
	Defective steam trap	Refer to Repair Procedure 5.3.11
Poor washing results	Detergent dispenser	Check dispenser
	not operating properly	
	Insufficient detergents	Refill containers
	Wash water temperature too low	See condition "Tank(s) water temperature is low when in use"
	Wash arm clogged	Clean
	Improperly scraped dishes	Check scraping procedures
	Ware improperly placed in rack	Use proper racks. Do not overload racks
	Drain-Overflow(s) clogged	Check overflow tubes
	debris not skimmed from tank(s)	
Wash water not drained at specified intervals	Drain tanks every two hours or after each meal period.	
Conveyor not moving dishracks	Drive motor V-belt broken	Replace drive belt
	Conveyor chain needs adjustment	Refer to Repair Procedure 5.3.16
	Conveyor shaft bearings defective	Refer to Repair Procedure 5.3.17 and Repair Procedure 5.3.18

5.3 Component Repair and Replacement

Part 5.3 contains instructions for the adjustment, repair, and replacement of components which may require service due to normal wear and tear. The following procedures should only be performed by qualified service personnel.

THE FOLLOWING CAUTION AND WARNINGS MUST BE FOLLOWED AT ALL TIMES:



CAUTION:

Only qualified service personnel should perform adjustments and repairs to the dishwasher.



WARNING:

When repairing a circuit, disconnect the power at the main service disconnect switch and place a red tag at the disconnect switch to indicate that work is being performed on the circuit.



WARNING:

Use extreme caution when performing tests on energized circuits.



WARNING:

*The conveyor drive contains moving parts.
Use caution when working around the conveyor drive assembly.*

5.3.1 Pressure Reducing Valve (PRV) Adjustment

The PRV is located on the 3/4" incoming water supply before the final rinse booster assembly. To adjust the pressure setting on the PRV, loosen the locknut on the adjusting screw in the top of the PRV. Turn the adjusting screw clockwise to increase the pressure setting. Turn the screw counterclockwise to decrease the pressure setting. The USN-72 dishwasher requires a flowing pressure of 20-22 PSI during the final rinse. With the dishwasher in normal operation, place a dishrack in the machine. While final rinse water is flowing, monitor the final rinse pressure gauge located at the top of final rinse piping assembly. Adjust the PRV screw to achieve a flowing pressure of 20-22 PSI.



The PRV does not contain any service replacement parts. If adjustment will not provide the proper flowing pressure, then replace the PRV. To replace the PRV: Turn main water supply to the dishwasher off. Place a rack in the dishwasher to activate the final rinse. This will bleed any water pressure out of the line. Remove the PRV from the piping system. Reinstall using pipe sealing compound. Turn the water supply on, test for leaks, and perform the adjustment described above.

5.3 Component Repair and Replacement (Cont.)

5.3.2 Water Line Strainers

There are two water line strainers on the USN-72 dishwasher. The first strainer is located on the 3/4" main water line to the booster. The second is located on the incoming water line for the tank fill. The line strainer screen may become clogged with debris. To clean the strainer screen: Turn off the main water supply valves. Open the tank fill manual valves to bleed off pressure. Run a dishrack through the machine to operate the final rinse and bleed off water pressure at the booster. Turn power off at the dishwasher control cabinet. Remove the locknut at the end of each strainer "Y." Remove the strainer screen and flush clean with water. Reinstall in reverse order. Turn on water supplies and check for leaks.

5.3.3 Vacuum Breaker Repair

Vacuum Breakers are located at the top of the USN-72 in the 3/4" final rinse water line and each of the 1/2" tank fill lines. They prevent the siphoning of dishwasher water back into the potable water supply. Each vacuum breaker contains a moveable float. To replace the float: Turn off the main water supplies. Turn off the power at the dishwasher control switch. Unscrew the top of the vacuum breaker. Remove the float. Inspect the interior of the vacuum breaker. Remove any mineral deposits and inspect the float seating surfaces for pitting. (If badly pitted, replace the entire vacuum breaker assembly). Install a new float repair kit and reassemble in reverse order. Turn on power and water supplies. Operate the dishwasher and check for leaks.



5.3.4 Water Solenoid Valve Repair

A 3/4" water solenoid is located in the final rinse water line at the outlet of the final rinse booster. The valve is controlled by the operation of the final rinse switch assembly which connects 120VAC to the valve coil during a final rinse operation. If the valve fails to operate, first check that 120VAC is supplied to the valve coil. If voltage is not present, then refer to the electrical schematic and troubleshoot the circuit. If voltage is present then the valve may require a rebuild kit or replacement coil. Turn off power at the dishwasher power switch and main disconnect. Turn off main incoming water supply and bleed off any water pressure in the line. Check the coil for continuity with a VOM set at the highest resistance range. If the coil checks good then disassemble the valve by unscrewing the threaded bonnet with a strap or spanner wrench. Remove and inspect the valve piston and diaphragm. Inspect the valve seat for mineral deposits and pitting. (Replace the complete valve assembly if pitting is severe). Reassemble the valve in reverse order. Turn on power and water supplies and check for leaks.



5.3.5 Float Switch Replacement

Refer to Fig. 6.12, , Part 6, Replacement Parts, for a detailed drawing of the float switch assembly. Each tank contains a float switch assembly which monitors the water level in the tank. When the water level drops below a preset level the ball on the float switch stem drops and opens a reed switch. The control relay associated with the float switch changes state. A set of normally closed contacts open interrupting power to the 120VAC control circuit and the dishwasher stops. If you suspect a defective float switch: Turn power off at the dishwasher control cabinet. Drain the tank and inspect the float. Make sure the float is clean and moves freely. Identify the float switch wires in the junction box located on the lower corner of the dishwasher front. Disconnect the float switch and connect its associated control wires together. Turn power on and restart the dishwasher. If the dishwasher operates normally, then replace the float. To remove the float assembly: Remove the float switch cover. Remove the 5/16-18 nut on the outside of the tank. The mounting hole is keyed so the float switch will not turn. Remove the float switch assembly from the inside of the tank. Install a replacement in reverse order. Reconnect the float switch wires in the junction box. Turn power on, refill the tank, and test the dishwasher for normal operation.

5.3.6 Drain Valve and Overflow Assembly

Refer to Fig. 6.15, Part 6, Replacement Parts, for a detailed drawing of the drain and overflow assembly. Note items 1-4. These parts make up the overflow assembly. The assembly consists of an overflow tube with drain box topped by a hinged cover. The cover tilts up to allow inspection and cleaning. Lift up the hinged cover and inspect the overflow tube if an obstruction is suspected. Item 10 shows the drain screen. This screen should be inspected daily and cleaned. Item 12 illustrates the drain assembly. It consists of soldered copper pipe and if defective must be replaced as a unit. Note the cleanout plug to the left of the drain valve. This plug can be removed to clean possible obstructions from the drain assembly. Item 13 shows the 1-1/2" cleanout plug in the drain trunk line. Remove the plug to inspect and clean the main dishwasher drain line.

5.3.7 Thermometer Replacement

Refer to Fig. 6.12, Part 6, Replacement Parts, for a detailed drawing of the thermometer assemblies. The thermometers are mounted to brackets on the top of the dishwasher*. Thermometer capillary tubes run from the top of the dishwasher to the right and left ends of the tanks. The thermometer bulbs are retained inside the tanks by a 1/2" locknut. The final rinse thermometer bulb mounts directly into the upper final rinse piping at the top of the dishwasher. Tank and final rinse thermometers are factory sealed indicating devices which are accurate within $\pm 3^\circ$ of the intended range of use. The thermometers cannot be calibrated and must be replaced if defective. To replace a thermometer: Drain the machine and turn off all power. Have a helper hold the thermometer bulb from the outside of the machine. Remove the 1/2" locknut from the inside of the tank and pull the thermometer sensor bulb out of the tank. Remove the nuts and retainer from the thermometer bracket. Pull the thermometer out the front of the bracket. Replace the thermometer and reassemble in reverse order. Be sure to apply plumber's putty, (Champion P/N 104889), to seal the thermometer bulb fitting in the tank. Return the dishwasher to normal operation and check the temperature reading.

*Wash tank and rinse tank thermometers are located on the lower front side of the wash and rinse tank.

The final rinse thermometer is located in the final rinse piping at the top of the dishwasher.

5.3 Component Repair and Replacement (Cont.)

5.3.8 Tank Heat Thermostat Adjustment and Replacement

Refer to Fig. 6.12, **B**, Part 6, Replacement Parts, for a detailed drawing of the thermostat assembly. Each tank has a control thermostat mounted on its front in a stainless steel enclosure. The thermostat capillary tubes run to either side of the tank. The thermostat sensor bulb enters the tank and is secured inside the tank with a 1/2" locknut. The thermostats are adjusted by turning a small adjustment screw mounted on the side of the device. The thermostats have an operating range of 110-200°F. Place the machine in normal operation and monitor the associated tank thermometer. Wash tank temperature should maintain a minimum of 150°F. Power rinse tank temperature should maintain a minimum of 160°F.

Wash Tank Temperature = 150°F minimum
Power Rinse Tank Temperature = 160°F minimum

To adjust a thermostat: Turn the adjusting screw incrementally 1/8 to 1/4 of a turn clockwise. Monitor the temperature thermometer after each adjustment until the desired temperature setting is maintained during normal dishwasher operation.

To replace a thermostat: Drain the tanks and turn off all power to the dishwasher. Have a helper hold the thermostat sensor bulb from the outside of the machine and remove the 1/2" locknut from the interior of the tank. Pull the bulb and capillary back to the thermostat junction box. Note the wire locations and disconnect the thermostat. Remove two retaining nuts and remove the thermostat assembly. Install a new thermostat in reverse order. Be sure to apply plumber's putty (Champion P/N 104889) to seal the thermostat bulb fitting in the tank. Return the dishwasher to normal operating condition and adjust the thermostat as described above.

5.3.9 Final Rinse (Steam) Thermostat Adjustment and Replacement

Refer to Fig. 6.16, Part 6, Replacement Parts, for a detailed drawing of the steam booster assembly. Note Items 10, 17 and 19. This shows the location of the final rinse control thermostat. The thermostat has a range of 50-300°F. However, the operating range for final rinse application is 180-195°F. The normally open contacts of the thermostat open on temperature rise. The normally closed contacts close on temperature rise. The thermostat's N.O. contacts are used for this application. The final rinse thermostat controls operation of the steam booster solenoid. It senses the outlet temperature of the final rinse water leaving the booster and energizes or deenergizes the steam solenoid as needed to maintain the final rinse temperature within 180-195°F.



Note Items 10, 17 and 15 in Fig. 6.16. This shows the location of the low temperature cutoff thermostat, (TSK). The final rinse thermostat and the low temperature thermostat are identical. The TSK has two applications. It may be used to immediately shut down the dishwasher in the event the final rinse water temperature falls below 180°F., or it may be used to activate a chemical sanitizing system (supplied by others) which does not immediately shut down the dishwasher.

NOTE:

The operation of the low temperature cutoff thermostat is dependent on the final rinse thermostat. Adjust the final rinse thermostat and the low temperature cutoff thermostat together.

5.3.9 Final Rinse (Steam) Thermostat Adjustment and Replacement (Cont.)

To adjust the final rinse thermostat: Turn power off to the dishwasher at the dishwasher control cabinet. Block the final rinse activator so the final rinse runs constantly. Return the dishwasher to normal operation. Remove the protective cap from the center of the final rinse thermostat enclosure to expose the adjusting screw. Turn the adjusting screw incrementally 1/16 of a turn clockwise to increase the final rinse temperature. Turn the screw counterclockwise to reduce the final rinse temperature. Monitor the final temperature thermometer after each adjustment until temperature maintains a minimum of 182-185°F.

NOTE:

The normally open contacts of the low temperature cutoff thermostat must close whenever the final rinse temperature falls below 180°F.

To adjust the low temperature cutoff thermostat: First perform the final rinse thermostat procedure described above. Turn the steam supply off to the booster assembly so the final rinse temperature falls below 180°F. Remove the protective cap from the center of the cutoff thermostat enclosure to expose the adjusting screw. Turn the adjusting screw incrementally 1/16 of a turn clockwise to increase the cutoff temperature. Turn the screw counterclockwise to reduce the cutoff temperature. In other words, if the final rinse water temperature is 182°F. and the low cutoff thermostat activated the chemical sanitizing system (supplied by others), then it would be necessary to turn the screw counterclockwise to reduce the cutoff temperature to 178-180°F.

To replace the final rinse or cutoff thermostat: Turn off the water and steam supplies to the booster. Place a rack in the dishwasher to operate the final rinse and bleed off any water pressure from the line. Turn power off to the dishwasher at the dishwasher control. Remove the protective cap and round cover from the thermostat body. Note the location of the wires and disconnect. Disconnect the conduit. Remove the thermostat from the booster piping. Install the replacement in reverse order. Return the dishwasher to normal operation and perform the adjustment procedures described above.

For machines S/N J1698 and after: To replace the control thermostat see the Special Bulletin Section on page 111 at the end of this manual for instructions on the replacement of the thermostat.

5.3.10 Steam Solenoid Valve Repair

The USN-72 dishwasher uses a 3/4" steam solenoid valve on each tank steam supply line. The 3/4" steam valves are identical in appearance to the 3/4" water valves, (See 5.3.4). The steam booster uses a 1" steam solenoid valve on the inlet of the booster steam supply line, (See picture at right).

The 3/4" valves are controlled by a tank heat thermostat, (See 5.3.8), which connects 120VAC to the valve coil during a call for heat. If the valve fails to operate, first check that 120VAC is supplied to the valve coil. If voltage is not present, then refer to the electrical schematic and troubleshoot the circuit. If voltage is present then the valve may require a rebuild kit or replacement coil. Turn off power at the dishwasher power switch and main disconnect. Turn off main incoming steam supply and bleed off any steam pressure in the line. Check the coil for continuity with a VOM set at the highest resistance range. If the coil checks good then disassemble the valve by unscrewing the threaded bonnet with a strap or spanner wrench. Remove and inspect the valve piston and diaphragm. Inspect the valve seat for mineral deposits and pitting. (Replace the complete valve assembly if pitting is severe). Reassemble the valve in reverse order. Turn on steam and power supplies and check for leaks.



5.3 Component Repair and Replacement (Cont.)

5.3.10 Steam Solenoid Valve Repair (Cont.)

The 1" valve is controlled by the final rinse control thermostat, (See 5.3.9), which connects 120VAC to the valve coil during a call for heat. If the valve fails to operate, first check that 120VAC is supplied to the valve coil. If voltage is not present, then refer to the electrical schematic and troubleshoot the circuit. If voltage is present then the valve may require a rebuild kit or replacement coil. Turn off power at the dishwasher power switch and main disconnect. Turn off main incoming steam supply and bleed off any steam pressure in the line. Check the coil for continuity with a VOM set at the highest resistance range. If the coil checks good then disassemble the valve by removing the four bolts in the valve bonnet. Remove and inspect the valve piston and diaphragm. Inspect the valve seat for mineral deposits and pitting. (Replace the complete valve assembly if pitting is severe). Reassemble the valve in reverse order. Turn on steam and power supplies and check for leaks.

5.3.11 Steam Trap Repair and Replacement

1/2" NPT thermodynamic steam traps are installed in the condensate lines for the steam booster and tank heat steam coils. All condensate lines for the USN-72 must be gravity drain with no back pressure in order for the steam trap to function correctly.

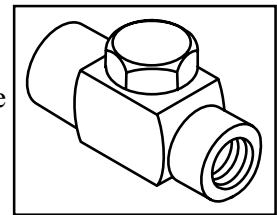

To test the operation of a steam trap: Turn off the steam and water supplies. Turn off the power at the dishwasher control cabinet. Bleed any steam pressure from the lines. Disconnect the condensate return line downstream from the steam trap. Return the dishwasher to normal operation and observe the discharge coming from the steam trap. If you do not observe small amounts of water periodically discharged then the steam trap is most likely defective.

To clean a steam trap: Turn off the steam and water supplies. Turn off the power at the dishwasher control cabinet. Bleed any steam pressure from the lines. Remove the large hex cap in the center of the steam trap. Remove the disc and inspect the steam trap orifice below. Clean the orifice with a paper clip or other smooth tool. Reassemble the trap in reverse order.

To replace a steam trap: Turn off the steam and water supplies. Turn off the power at the dishwasher control cabinet. Bleed any steam pressure from the lines. Break the union in the condensate line before the steam trap. Remove the trap. Install a replacement trap in reverse order making sure to apply pipe sealant to threads. Return the dishwasher to normal operation and test the trap as described above.

5.3.12 Steam Booster Service

Refer to Fig. 6.16, Part 6, Replacement Parts, for a detailed drawing of the steam booster assembly. The steam booster consists of three pieces as shown on the next page: the shell casting into which the straight seamless copper tubes are fitted, the rear header, and the flow header with two tappings for tank connections. Headers are bolted to the shell casting and sealed against leaks by heavy gaskets. Where soft water or low percentage of mineral deposits is used, it should only be necessary to clean the heater tubes annually. No acids are needed to clean the heater tubes.



NOTE:

A single spiral, fine wire brush, 3/4" external diameter (Champion P/N 112806) or comparable is recommended for cleaning the booster heater tubes.

5.3.12 Steam Booster Service (Cont.)

Annual Heater Tube Cleaning

Parts Required:

P/N 112357, Gasket (Return header)

P/N 112356, Gasket (Flow header)

Special Tools Required:

Torque wrench (30 ft/lbs needed)

To clean the heater tubes: Turn off all power, steam, and water supplies to the booster and dishwasher.

Refer to Fig. 6.16, Part 6, Replacement Parts. Note thermostats (item- 10).

Remove the thermostat covers, mark and disconnect the wires. Remove the conduit and fittings. Mark the location of each thermostat before removal, then unscrew each thermostat from its piping. Break the unions (item 12) and remove the piping assemblies from the booster header. Remove the eight (8) bolts from each header. Remove the flow and return headers.

Inspect the exposed copper tubes and clean as necessary using the cleaning brush (Champion P/N 112806). Clean the headers as required.

Install new header gaskets and reassemble in reverse order.

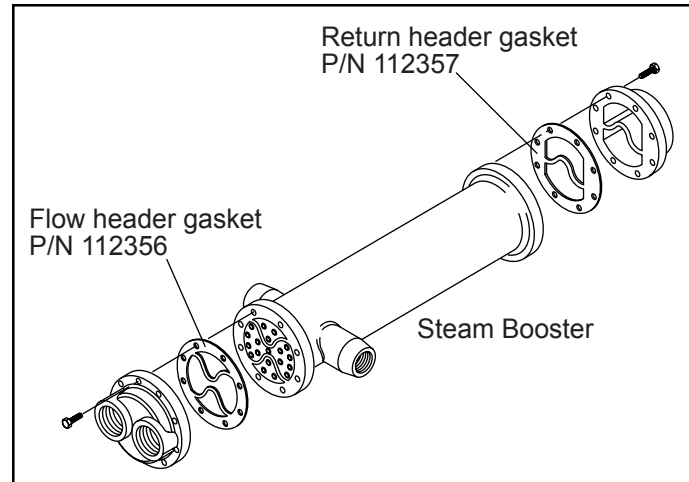

To torque the header bolts:

Refer to the torque sequence diagram to the right.

Torque each bolt in three steps:

- 1) handtight
- 2) 20 ft/lb
- 3) 30 ft/lb

Retorque each bolt to 30 ft/lb after 24 hours.

Bolts = 3/8-16
SA-449
Type 1

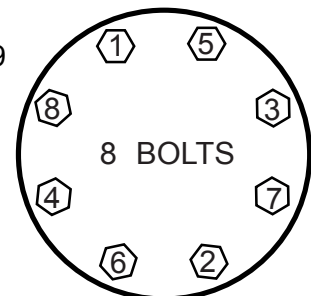

5.3 Component Repair and Replacement (Cont.)

5.3.13 Wash Manifold Restrictor Adjustment

Refer to Fig. 6.14, Replacement Parts, Item 8. The illustration shows the slide restrictor mounted in the lower wash manifold of each tank. The restrictor is set at the factory but may be adjusted if necessary. The factory setting evenly balances the water pumped to the upper and lower spray pipes. If more water is required in the lower pipes, then the restrictor should be pulled out. If less water is required in the lower spray pipes, then the restrictor should be pushed in.

To adjust the restrictor: Turn off power at the dishwasher control cabinet. Loosen the manifold bolts (Item 2) in the lower manifold. Move the restrictor to the desired position. Tighten the manifold bolts. Turn on power and operate the dishwasher. Observe the spray pattern between the upper and lower spray pipes. The lower spray pattern should not be reduced to less than 1/3 of the upper spray pipe water pattern because washing results may suffer as a result.

5.3.14 Pump Seal Replacement

Refer to Fig. 6.13, Replacement Parts, for a detailed drawing of the pump/motor assembly. Perform the steps listed below to replace a pump seal.

1. Disconnect the power to the machine at the main breaker panel or fuse box.
2. Drain the machine.
3. Remove the front and side panels (if applicable).
4. Remove drain plug on the pump volute and drain the pump.
5. Remove the pump hoses.
6. Disconnect the wires to the motor at the motor junction box.
7. Unbolt motor from machine base and remove the pump/motor assembly.
8. Remove bolts on volute and carefully remove from the pump flange.
9. Remove the impeller retaining bolt and nut from center of impeller.
10. Lock the motor shaft with a wrench or pliers. The back of motor shaft is square.
11. Turn the impeller counterclockwise to remove from shaft (right hand threads).
12. Remove the old seal and discard.
13. Check seal seat in the pump flange and clean thoroughly.
14. Press rubber seal/ceramic portion of seal assembly into the pump flange. Use a water soluble lubricant. Be careful to keep the ceramic clean.
15. Install the rotating part of the seal on the shaft with the graphite surface toward the ceramic. Use a water soluble lubricant on the rubber seal part only (not the graphite).
16. Reinstall impeller, and new flange gaskets. Reinstall bolts. Reinstall drain plug.
17. Reinstall the pump/motor assembly and reconnect the pump hoses.
18. Fill the dishwasher with water.
19. Check motor rotation by bump starting motor.
Correct motor shaft rotation is clockwise when viewing motor from the rear.
20. Test run and check for leaks.

5.3.15 Rinse Saver Assembly Repair

Refer to Fig. 6.8, Part 6, Replacement Parts, for a detailed drawing of the rinse saver assembly. The rinse saver assembly, located at the unload end of the dishwasher, consists of a dishrack actuated paddle assembly, a magnet, and a magnetic reed switch mounted on the underside of the hood assembly. As a dishrack approaches the final rinse area, it contacts the paddle assembly. The magnet moves away from the magnetic reed switch mounted underneath it. The reed switch contacts close deenergizing 4CR relay. 4CR N.C. contacts close and power is applied to the final rinse water solenoid valve.

If the final rinse switch were to fail with its contacts closed, the resulting condition would be no final rinse assuming all other components operate normally.

If the final rinse switch were to fail with its contact open, the resulting condition would be continuous final rinse.

To replace the final rinse switch: Turn off power at the dishwasher control cabinet. Remove the switch cover box. Note the orientation of the magnetic reed switch before removal. Remove the two (2) retaining nuts holding the switch. Install the replacement and reassemble in reverse order. Return the machine to normal operation. Insert a dishrack into the machine to verify proper final rinse operation.

5.3.16 Conveyor Chain Take-up Assembly Adjustment

Refer to Fig. 6.6, Part 6, Replacement Parts, for a detailed drawing of the take-up assembly. The take-up assembly provides the means to compensate for wear in the conveyor chains. Adjustment is made by turning the two adjusting screws (Item 1) to maintain proper tension.



NOTE:

Correct chain tension occurs when the chains can be lifted off the tracks a maximum of 1-1/2" measured at the center of the dishwasher.

To adjust the chain tension: Turn off power at the dishwasher control cabinet. Drain the machine and remove the curtain assemblies. (Refer to Fig 6.5, Replacement Parts, Items 1-3). Check the chain guides before beginning the chain adjustment. Replace the guides if worn. (Refer to Fig.6.6). Check the chain tension and estimate the amount of adjustment required. Check the alignment of the conveyor shaft; the shaft and chain gears should be even on both sides. Loosen the jam nuts (Item 2). Turn the adjusting screws (Item 1) evenly on both sides. Check the distance the chain can be lifted off the center portion of the tracks after each adjustment. When the chain tension is correct, tighten the jam nuts. Return the dishwasher to normal operation and check that the chains track evenly on both sides and engage the drive gears smoothly. Stop the dishwasher and recheck the chain tension. Return the dishwasher to service.

5.3 Component Repair and Replacement (Cont.)

5.3.17 Take-up Bearing Replacement

Refer to Fig. 6.6, Replacement Parts, for a detailed drawing of the take-up assembly. It is recommended to replace both take-up bearings at the same time.

To replace the bearings: Turn off all power to the dishwasher. Drain the tanks and remove the curtains and doors. Loosen the jam nuts (Item 2) and remove all tension from the chains. Locate the conveyor chain master links (1 per chain) and remove. Pull the chains off the load end gears and toward the unload end of the machine. Remove the take-up assembly mounting bolts, (Items 12-14). With the aid of an assistant, lift the entire assembly off the lower mounting studs. Turn the assembly diagonally in the machine until one end of the shaft extends out the load end of the dishwasher. Remove the assembly from the machine. Remove the set screw from one of the chain drive gears and remove the gear. Remove the set screws from the take-up bearings. Pull the drive shaft out of the bearings. Snap the take-up bearings out of the housings, (Items 5-6). Replace the bearings and reassemble in reverse order. Adjust the chain tension as described in Part 5.3.16.

5.3.18 Drive Shaft Bearing and Seal Replacement

Refer to Fig. 6.6, Replacement Parts, for a detailed drawing of the take-up assembly and the drawing below for a detailed view of the drive shaft seal assembly. It is recommended to replace both drive shaft bearings at the same time.

To replace the bearings: Refer to Fig 6.6, Replacement Parts. Turn off all power to the dishwasher. Drain the tanks and remove the curtains and doors. Remove the chain drive cover at the unload end of the machine. Loosen the jam nuts (Fig. 6.6, Item 2) and remove all tension from the chains. Locate the conveyor chain master links (1 per chain) and remove. Pull the chains off the unload end gears and toward the load end of the machine.

Refer to the drawing at right and Fig 6.5, Part 6, Replacement Parts.

Remove the master link from the #50 drive chain on the outside of the machine. Remove the set screws from the main drive gear. Remove the drive gear. Loosen the set screws from the interior stainless steel drive gears. Remove set screws from the drive shaft bearings. Remove the seal from the bore of the front drive shaft bearing. With the aid of an assistant, pull the conveyor drive shaft out the front of the machine. Remove the four (4) screws holding each of the drive shaft bearings. Replace the bearings and reassemble in reverse order. When the drive shaft is set in the rear bearing, install a new seal. Complete the reassembly. Adjust the chain tension as described in Part 5.3.16. Return the dishwasher to service.

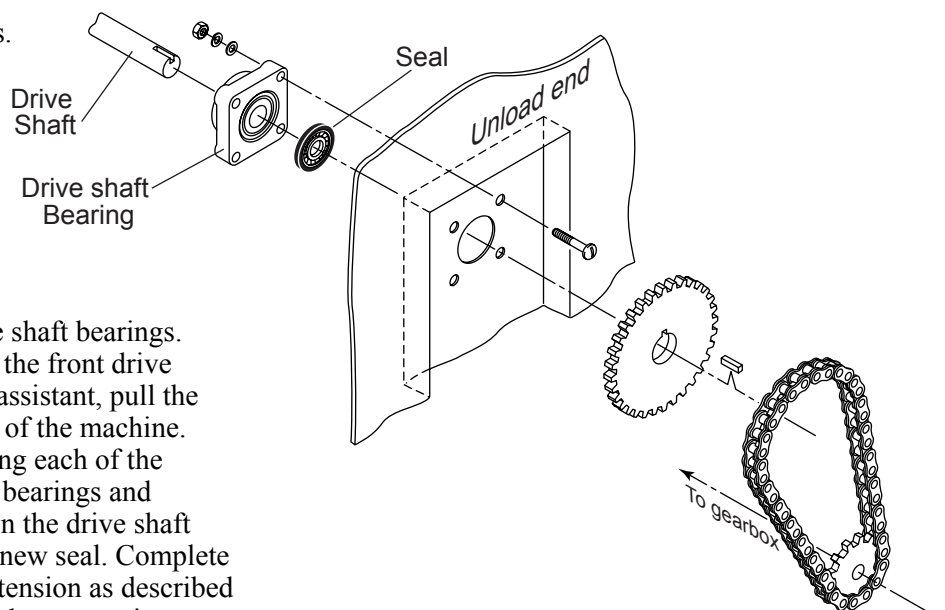

5.3.19 Door Safety Switch Replacement

Refer to Fig. 6.12, **A**, Part 6, Replacement Parts, for a detailed drawing of the door switch assembly. The door safety switch assembly consists of a magnet installed in each lift-out door and a magnetic reed switch mounted in an enclosure beneath the door frame. The door safety switch prevents the dishwasher from operating if a door is missing or lifted during operation.

To check a door safety switch: Turn power off at the dishwasher control cabinet. Inspect the door to ensure the magnet is in place and secure. Remove the door switch cover and disconnect the reed switch leads. Make sure all doors are fully closed. Connect the door safety switch harness wires together. Turn power on and check if the machine runs normally. If machine operates, turn off power and replace the door switch. Do not leave the door switch bypassed for any reason other than testing.

To replace a door safety switch: Turn power off at the dishwasher control cabinet. Note the orientation of the reed switch. Mark the wires and disconnect. Remove the two (2) retaining nuts holding the switch. Install the new switch and reassemble in reverse order. Turn power on and operate the dishwasher. Check the switch operation by carefully lifting the door approximately 1". The dishwasher should stop. Return the dishwasher to service.

5.3.20 Control Circuit Explanation

The following explanation provides background information for Parts 5.3.21 through 5.3.24.

The USN-72/S is a steam heated, 2-tank rack machine. The USN-72/S is to have the following control features/functions:

- 1.) Wash down duty motors.
- 2.) 2 HP wash and rinse tank pumps.
- 3.) Machine to not function when booster temp. falls below 180°F.
or to switch to a chemical sanitizing system (supplied by others).
- 4.) Manual filling of the tanks.
- 5.) NEMA 4X control box that is remote mounted.
- 6.) Float tank protection with a 5 second debounce.
- 7.) 120V control voltage.
- 8.) Door safety switches.
- 9.) Rinse saver for potable water conservation.

5.3 Component Repair and Replacement (Cont.)

5.3.20 Control Circuit Explanation (Cont.)

INITIAL STATE OF THE MACHINE

Doors open
Power off
Tanks empty
Booster full of water
End of cycle

THEORY OF OPERATION

The days first operation should find the machine in the above condition. The operator is to then fill the machine through the manual ball valves to the specified level suitable for operation. At this point the machines power switch, SW, can be turned to the “ON” position.

1.) THE “CB” CIRCUIT BREAKER

The purpose of this device is to limit the machines control current and is rated for 5A. The normal state of this device is closed. When the control circuit has a current fault the breaker will open, the button on the face of the breaker will push out, and shut down the machines operation. It is reset by pushing the button on the face back in.

2.) THE “SW” POWER SWITCH

The purpose of this device is to turn the machine on and off. In the “ON” position, the switch passes power from the circuit breaker, CB, to wire #3. With the switch “ON” the power on light, “PL”, will illuminate. Wire #3 is the controlling voltage that allows other devices to operate with no other conditions satisfied other than the power being on. These devices include:

A.) 1CR. The relay 1CR monitors the state of the door switches. If either the wash or rinse tank door is open the relay will not energize. Contacts on this relay prohibit the pumps and conveyor from running when the doors are open, they prohibit the final rinse valve from energizing with the doors open, and prohibit the steam coils from energizing with the doors open.

B.) WFSW The device WFSW is the wash tank float switch. When the wash tank is empty the magnet in the float causes a reed switch in the stem to close. This energizes the wash tank float switch relay, 6CR.

C.) RFSW The device RFSW is the rinse tank float switch. When the rinse tank is empty the magnet in the float causes a reed switch in the stem to close. This energizes the rinse tank float switch relay, 7CR.

D.) RT The device RT is the rinse tank float switch timer. This timer is a motor and clutch type device. When the rinse tank is empty relay 7CR energizes opening 7CR N.C. This removes the voltage from the clutch of the timer and begins the 5 second low water timing operation. After the power has been absent for 5 seconds the N.C. contacts of RT opens causing relay 3CR to de-energize. The N.O. contacts of 2CR in the pump and conveyor hold-in circuit (see PUMP AND CONVEYOR HOLD-IN CIRCUIT for details) open and cause the contactors to drop out. Whenever power is reapplied to the clutch the N.C. contact of RT closes and relay 2CR reenergizes. Providing the rest of the hold-in circuit is satisfied the pumps and conveyor can then be restarted with the START button.

E.) WT The device WT is the wash tank float switch timer. This timer is a motor and clutch type device. When the wash tank is empty relay 6CR energizes opening 6CR N.C. This removes the voltage from the clutch of the timer and begins the 5 second low water timing operation. After the power has been absent for 5 seconds the N.C. contacts of WT opens causing relay 2CR to de-energize. The N.O. contacts of 3CR in the pump and conveyor hold-in circuit (see PUMP AND CONVEYOR HOLD-IN CIRCUIT for details) open and cause the contactors to drop out. Whenever power is reapplied to the clutch the N.C. contact of WT closes and relay 3CR reenergizes. Providing the rest of the hold-in circuit is satisfied the pumps and conveyor can then be restarted with the START button.

F.) TLS The device TLS is a table limit switch. The state of this switch drives the relay 5CR. The contacts of this relay are used in the pump and conveyor hold-in circuit.

3.) PUMP AND CONVEYOR HOLD-IN CIRCUIT

The pump and conveyor hold-in circuit consists of switches, contacts, and buttons used to energize the pump and conveyor contactors. This circuit is satisfied under the following conditions:

A.) xMOL - The pump and drive overloads are wired in series through the N.O. contacts of each individual overload. In the normal operating state, the switch lever is in the up position with a white "1" visible against a black background. In this position the N.O. contacts are closed and remain closed until an over current condition occurs that causes the contacts to open back up. Once the cause of the fault has been corrected these overloads can be reset by flipping the switch to the up position

B.) 5CR - The N.O. contacts of 5CR will prevent the machine continuing to operate until the rack causing the fault is removed. This prevents racks from jamming in the machine.

C.) MSW - The MSW limit switch is located under the conveyor motor drive base and its normal state is closed. It prevents the machine from operating if the conveyor drive mechanism senses an over torque condition. If a rack conveyor jam occurs, the gearbox will attempt to climb the drive chain. Since the gearbox is attached to a plate that pivots vertically, the switch opens when the gearbox climbs the drive chain. This switch is reset by mechanically fixing the conveyor jam.

5.3 Component Repair and Replacement (Cont.)

5.3.20 Control Circuit Explanation (Cont.)

D.) TSK - The TSK is the thermal kill switch that prevents the machine from operating when the final rinse water in the booster is below 180°F. The N.O. contacts of this thermostat open on temperature rise. When a fault occurs the indicator light TKL illuminates and the hold-in circuit drops out. At the beginning of the day the water in the booster is cold and the steam valve is off. If the rinse tank is filled with water and the doors are closed the valve BC1 will energize and allow steam to flow through the heat exchanger in the booster. After a short period of time the water in the booster will heat enough to satisfy the thermostat. If the machine has sat idle for a while the water in the piping may cool enough to cause the thermostats N.C. contacts to open. This condition can be corrected by holding in the START button. This causes the relay 4CR to de-energize and power to pass through the N.C. contacts of 4CR to the final rinse valve FRV. When the thermostat is satisfied the indicator light TKL will extinguish and the START button can be released. If all other conditions in the pump and conveyor hold-in circuit are satisfied the machine will automatically restart.

E.) 2CR and 3CR N.O. - The 2CR and 3CR N.O. contacts prevent the pumps from running if there is not water in either of the two tanks. The circuit controlling these contacts have a 5 second delay in them to allow for the ships rolling and pitching without false stopping.

F.) START BUTTON - The start button has two functions in this machine. The first, and most obvious, is to begin the machine operating. If all other devices in the hold-in circuit are satisfied the N.O. contact of contactor 1M will seal in the START button once it is released. The second is to allow water to flow by the thermal kill switch after the switch has shut down the pump and conveyor hold-in circuit. The start button acts as priming device to get hot water flowing past the TSK so the switch will close again.

G.) STOP BUTTON - The STOP button will cause the N.O. contact of the contactor 1M to open after the machine has begun operating. This in turn causes the hold-in circuit to drop out and the machine to cease functioning.

H.) 1CR N.O. - The N.O. contact of 1 CR opens whenever either access door is opened. The pump and conveyor hold-in circuit will not function until the doors are closed. This contact also prevents the final rinse valve, FRV, from energizing and spraying hot water until the doors are closed. This contact also will not allow any steam valve to energize when the doors are open. This will lessen the chance that someone will get burned by a tank heater coil while cleaning the machine.

5.3.21 Control Cabinet Fuse Replacement

Two fuse holders, located in the dishwasher remote control cabinet protect the main control transformer. Each fuse block holds a 3 amp fuse. The fuses are marked 1FU and 2FU on the schematic.

To replace a fuse: Turn off the power to the dishwasher at the main service disconnect switch. Flip the tab on the top of the fuse holder to open the holder. Remove the fuse and replace with a fuse of the same amp rating. The picture to the right shows the fuse holder open and the fuse exposed.



5.3.22 Motor Overload Adjustment and Replacement

Each motor has an overload to protect it from line voltage electrical overloads. The overload disconnects 120VAC power to the motor contactor coil.

Refer to the picture to the right.

Note the Switch Lever on the Overload.
If the switch lever is off with the “0” showing then the overload has tripped.

To Reset the Motor Overload:
Flip the overload switch to the On position. A “1” should be visible on the switch lever.

To Replace a Motor Overload:
Disconnect the wires to the overload.
Release the mounting catch on the front side of the overload. Push forward and lift out.
Snap the new overload into place and reconnect the wires.

To adjust the overload setting:
The screwdriver is positioned to adjust the motor overload AMP setting.
Read the full load amps (FLA) motor amps on the motor nameplate.
Adjust the overload dial to match the nameplate FLA of the motor.

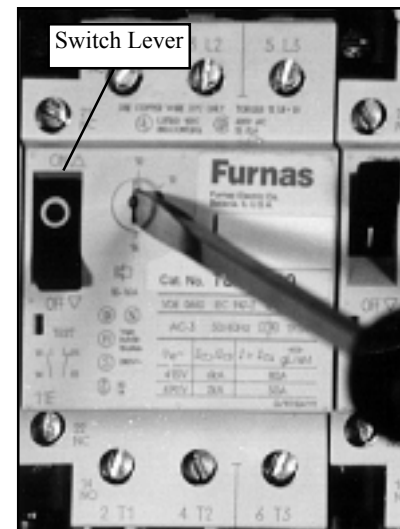

5.3 Component Repair and Replacement (Cont.)

5.3.23 Timer Settings

There are adjustable cycle timers located in the dishwasher control cabinet. They are designated WT and RT on the electrical schematic. The timers are 8 pin plug in modules with two (3) user defined settings.

To set a timer: Hold the replacement timer with the timer dial facing up. Locate the setting in the upper right corner of the timer. Turn the adjust screw to 60 S for (60 seconds). Flip the timer over to view the back and make sure the setting in the lower left corner is set to 60 for 60 Hertz. Finally, turn the timer over to view the timer dial again and set the timer dial to 5 for five seconds.

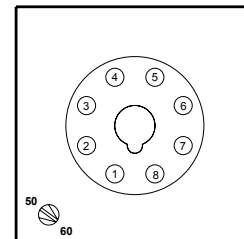
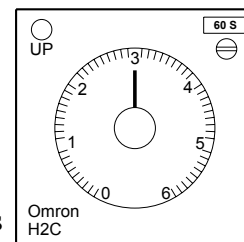

5.3.24 Control Cabinet Pilot Light Bulb Replacement

There are two pilot lights on the front of the dishwasher control cabinet. One indicates Power On; the other indicates either Low Booster Temperature, or Reset Required. If the dishwasher is equipped with a final rinse chemical sanitizing system then the pilot light indicates Reset Required.

To replace an indicator bulb: Turn off the power at main service disconnect switch. Open the control cabinet cover and locate the desired pilot light assembly. Push the pilot light locking tab 1/4 turn in a clockwise direction as viewed from the front to release the light assembly from its mounting socket. Remove the bulb by turning it gently 1/2 turn in either direction. Install a replacement bulb and reassemble in reverse order. Return the dishwasher to normal operation.

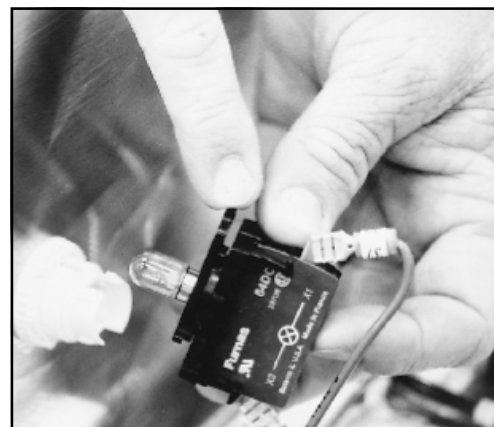

**THIS PAGE
INTENTIONALLY
LEFT BLANK**

PART 6: REPLACEMENT PARTS

In This Part—

- Introduction
- Parts illustrations and replacement parts lists

6.1 Introduction

Part 6, Replacement Parts covers parts illustrations and parts lists for the major components of your dishwasher. Parts lists are not provided for permanently assembled, (e.g. welded assemblies), items nor for items unsuited for field replacement.

Parts lists contain the current Champion part number or the abbreviation "Coml" which indicates the part may be available locally or fabricated from raw materials onboard ship. The "Coml" part number is primarily used for common pipe and pipe fittings.

6.2 Parts Procurement

All parts are available from:
The Source
502 Rotary Street
Hampton, VA 23661

You also can contact The Source by telephone or fax, Monday through Friday, except holidays from 8 AM till 5 PM EST:

Tel: 1 (757) 825-1400
1 (800) 497-2144
Fax: 1 (757) 825-1202
website: www.thesource2000.net

Email:

Equipment Information HQ - Darlene Ehrenfried	darlene.ehrenfried@thesource2000.com
Parts Information HQ - Lori Hicks	lori.hicks@thesource2000.com
Service Information HQ - Jim Luther	jim.luther@thesource2000.com
U.S. Navy POC - Nigel Pearce, San Diego, CA	nigel.pearce@thesource2000.com
U.S. Navy POC - Tony Cox, Mayport, FL	tony.cox@thesource2000.com
U.S. Navy POC - Janet Searls, Norfolk, VA	janet.searls@thesource2000.com

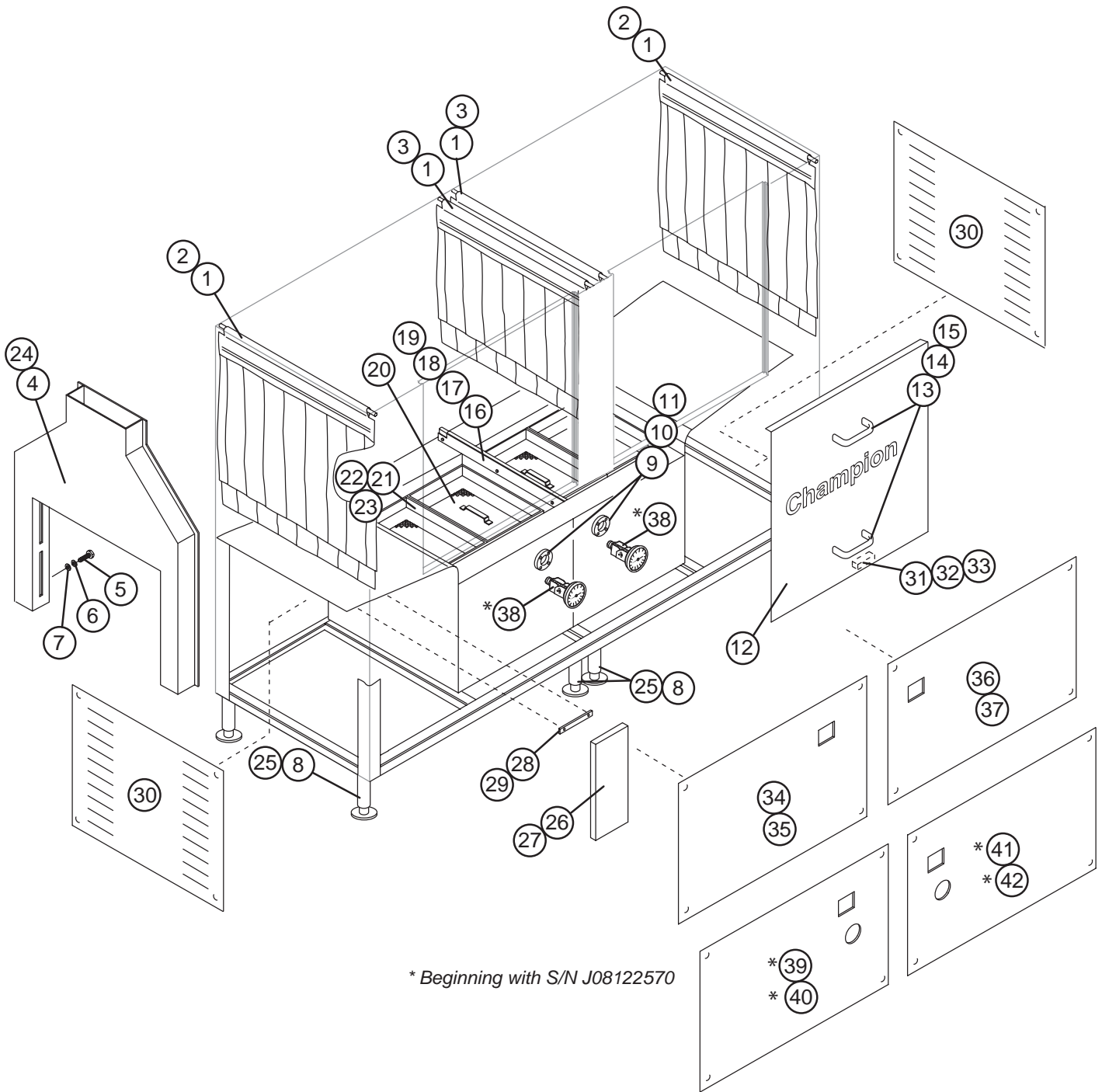

Figure 6.1
Vents, Curtains, Doors, Panels,
Scrap screens, and Water level gauges
(R-L machine shown)

**VENTS, CURTAINS, DOORS, PANELS,
SCRAP SCREENS, AND WATER LEVEL GAUGES
(R-L MACHINE SHOWN)**

Fig. 6.1 Item No.	Part No.	Part Description	Qty.
1	108250	Rod, curtain (Beginning w/S# J1921, 1 additional rod added/ 3 prior)	4
2	108042	Curtain, long	2
3	108043	Curtain, short (Beginning w/S# J1921, 1 additional curtain added/ 1 prior)	2
4	323021	Vent Assy. LH	1
5	100735	Screw, 1/4-20 x 5/8"	12
6	106482	Washer, lock 1/4"	12
7	106026	Washer, flat 1/4"	12
8	317331	Feet, flanged (Prior to S/N J1588)	8
8	325351	Feet, flanged (After S/N J1589)	8
9	200087	Gauge, water level sight	2
10	107970	Screw, 8-32 x 1"	8
11	107966	Nut, lock 8-32	8
12	322712	Assy., lift-out door	2
13	108966	Handle, door	4
14	100779	Screw, 1/4-20 x 5/8"	8
15	106482	Washer, lock 1/4"	8
16	322839	U-clip	1
17	100734	Screw, 1/4-20 x 1/2"	3
18	106482	Washer, lock 1/4"	3
19	10003	Nut, 1/4-20	3
20	322763	Screen, scrap	4
21	322705	Bracket, screen support	2
22	106727	Screw, flat HD, 10-32 x 5/8"	8
23	104985	Nut, hex 10-32	8
24	322770	Vent Assy. RH (not shown)	1
25	110235	Leg Assy.	8
26	322901	Cover, drive chain (R-L machine)	1
27	322972	Cover, drive chain (L-R machine)	1
28	323241	Bracket, offset	1
29	107967	Nut, lock 1/4-20	2
30	325344	Panel, end	2
31	111026	Magnet, door safety	2
32	108954	Nut, grip 6-32	4
33	104883	Screw, 6-32 round head	4
34	323432	Panel, wash tank (L-R), (Prior to S/N J08122570)	1
35	323433	Panel rinse tank (R-L), (Prior to S/N J08122570)	1
36	323431	Panel, rinse tank (L-R), (Prior to S/N J08122570)	1
37	323434	Panel, wash tank (R-L), (Prior to S/N J08122570)	1
38	114563	Thermometer, 3" Dial, 20-240°F, Hinged (Beginning with S/N J0881570)	2
39	XXXX	Panel, wash tank (L-R), (Beginning with S/N J08122570).....	1
40	XXXX	Panel, Rinse tank (R-L), (Beginning with S/N J08122570).....	1
41	XXXX	Panel, Rinse tank (L-R), (Beginning with S/N J08122570).....	1
42	XXXX	Panel, wash tank (R-L), (Beginning with S/N J08122570).....	1

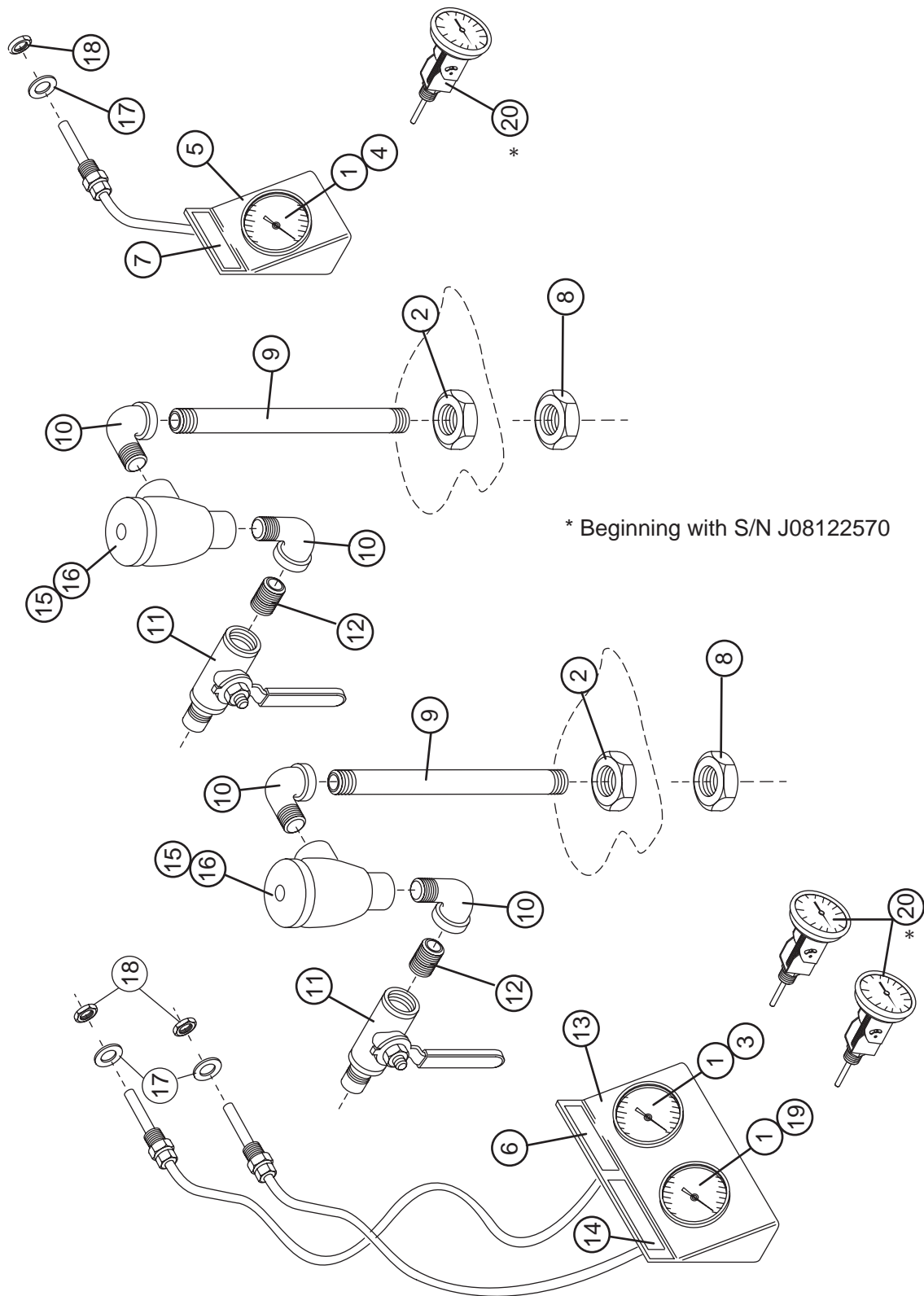

Figure 6.2 -
 Tank fill assembly and Temperature gauges
 (R-L machine shown)

TANK FILL ASSEMBLY AND
TEMPERATURE GAUGES
(R-L MACHINE SHOWN)

Fig. 6.2 Item No.	Part No.	Part Description	Qty.
1	107440	Thermometer, (Prior to S/N J08122570).....	2
2	Coml	Locknut, 1/2" NPT brass	2
3	112088	Label, rinse 160°F, (Prior to S/N J08122570).....	1
4	112086	Label, wash 150°F, (Prior to S/N J08122570).....	1
5	323240	Bracket, gauge, top mounted (single), (Prior to S/N J08122570).....	1
6	112778	Label, Rinse, (Prior to S/N J08122570).....	1
7	112777	Label, Wash, (Prior to S/N J08122570).....	1
8	201029	Locknut, 1/2" NPT brass, nickel plated	2
9	Coml	Nipple, 1/2" NPT x 6-3/4" RTOE brass	2
10	Coml	Steel elbow, 1/2" NPT brass	4
11	104749	Ball valve, 1/2"NPT M x F Bronze	2
12	Coml	Nipple, close, 1/2" NPT brass	2
13	325495	Bracket, gauge, top mounted (double)	1
14	112803	Overlay, Final Rinse, (Prior to S/N J08122570).....	1
*15	100500	Vacuum breaker, 1/2" brass	2
*16	108349	Repair kit vacuum breaker, 1/2" (Prior to S/N J1533) (Bronze)	2
*16	113221	Repair kit vacuum breaker, 1/2" (After S/N J1534) (Plastic)	2
17	201041	Washer, 7/8" ID x 1 3/16" (Prior to S/N J08122570).....	3
18	100547	Locknut, 1/2" NPT, SST (Prior to S/N J08122570).....	3
19	112090	Overlay, final rinse 180°F, (Prior to S/N J08122570).....	1
20	114563	Thermometer, 3" Dial, 20-240°F, Hinged	1
		<i>Beginning with S/N J08122570)</i>	
--	900836	Kit* Repair, 1/4" and 1/2" Vacuum Breaker Includes 1 each of P/N 108349, 113219, and 113221)	

* Kit 900836 was created to repair either style of vacuum breaker (bronze or plastic). Plastic style are no longer available for the complete vacuum breakers, must replace with the bronze style when replacing complete vacuum breaker.

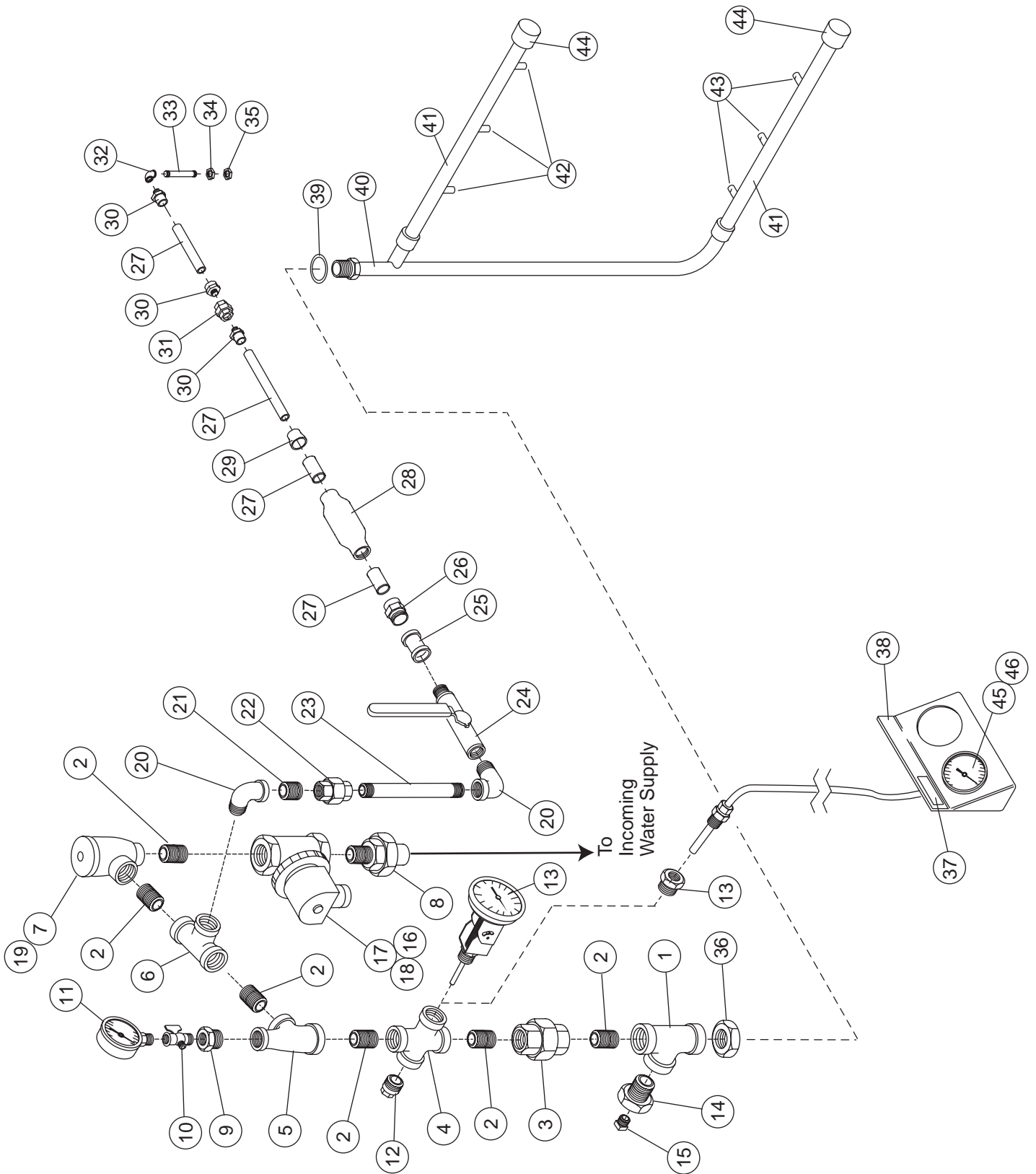

Figure 6.3 -
Final rinse piping assembly
(R-L machines shown)

FINAL RINSE PIPING ASSEMBLY
(R-L MACHINE SHOWN)

Fig. 6.3 Item No.	Part No.	Part Description	Qty.
1	102522	Tee 3/4" SST	1
2	Coml	Nipple, close 3/4" NPT brass	6
3	Coml	Union, 3/4" brass	1
4	Coml	Cross, 3/4" brass	1
5	Coml	Tee, reducing 3/4" x 1/2" x 3/4" brass	1
6	Coml	Tee, reducing 3/4" x 3/4" x 1/2" brass	1
* 7	104429	Vacuum brkr, 3/4" NPT (Bronze)	1
8	Coml	Union copper, 3/4" NPT x 3/4" c	1
9	Coml	Bushing reducing, 1/2" x 1/4" brass	1
10	100123	Petcock, 1/4"	1
11	100135	Pressure gauge, 1/4" NPT O-60	1
12	Coml	Plug, 3/4" NPT brass	1
13	114563	Gauge 3" Dial, 20°-240°F, Hinged (<i>Beginning with S/N J08122570</i>).....	1
13	Coml	Bushing reducing, 3/4" x 1/2" brass (<i>Prior to S/N J08122570</i>).....	1
14	Coml	Bushing reducing, 3/4" x 1/4" NPT brass	1
15	110855	Plug 1/4" NPT Plastic	1
16	111437	Valve, 3/4" Hot water 120VAC coil	1
17	109903	Kit , Repair	1
*18	108516	Solenoid, 3/4" valve 120VAC	1
*19	108351	Repair kit vacuum brkr, 3/4" (Prior to S/N J1533)	1
19	113223	Repair kit vacuum brkr, 3/4" (After S/N J1534)	1
--	900837	Kit*Repair, 3/4" Vacuum Breaker (Includes one each of 108351 & 113223)	
20	102438	Elbow Street 1/2" X 90°	2
21	100209	Nipple, close 1/2 NPT brass	2
22	102549	Union, 1/2" NPT brass	1
23	111287	Nipple 1/2 NPT x 5-1/2" brass	1
24	104749	Ball Valve, 1/2" NPT M x F Bronze	1
25	102412	Coupling, 1/2" NPT brass	1
26	107448	Adapter, 1/2" x 1/2" Copper	1
27	107315	Tubing, copper 3/8" Type L	A/R
28	112825	Flow Control, 1GPM 1/2 NPT	1
29	102388	Bushing, reducer 1/2" x 1/4"	1
30	108254	Adapter, 3/8" x 1/4" NPT copper	4
31	101265	Union 1/4" NPT brass	1
32	102422	Elbow, 1/4 NPT x 90° brass	1
33	112109	Nipple, RTOE 1/4" x 2-1/2" brass	1
34	100573	Locknut 1/4 NPT brass	1
35	201669	Locknut 1/4 NPT Nickel plate	1
36	Coml	Locknut, 3/4" NPT brass	1
37	112803	Label, final rinse (<i>Prior to S/N J08812570</i>).....	1
38	325495	Bracket, gauge top mounted (double) (<i>Prior to S/N J08812570</i>).....	1
39	108620	Gasket final rinse	1
40	323233	Final rinse manifold (L-R machine)	1
—	323234	Final rinse manifold (R-L machine)	1
41	205421	Final rinse pipe, upper and lower	2
42	106530	Final rinse nozzle, upper	3
43	112022	Final rinse nozzle, lower	3

FINAL RINSE PIPING ASSEMBLY
(R-L MACHINE SHOWN)

Fig. 6.3 Item No.	Part No.	Part Description	Qty.
44	106734	End cap, plastic	2
45	107440	Thermometer (<i>Prior to S/N J08122570</i>)	1
46	112090	Overlay, final rinse 180°F (<i>Prior to S/N J08122570</i>)	1

* Kit 900837 was created to repair either style of vacuum breaker (bronze or plastic). Plastic style are no longer available for the complet vacuum breakers, must replace with the bronze style when replacing complete vacuum breaker.

**THIS PAGE
INTENTIONALLY
LEFT BLANK**

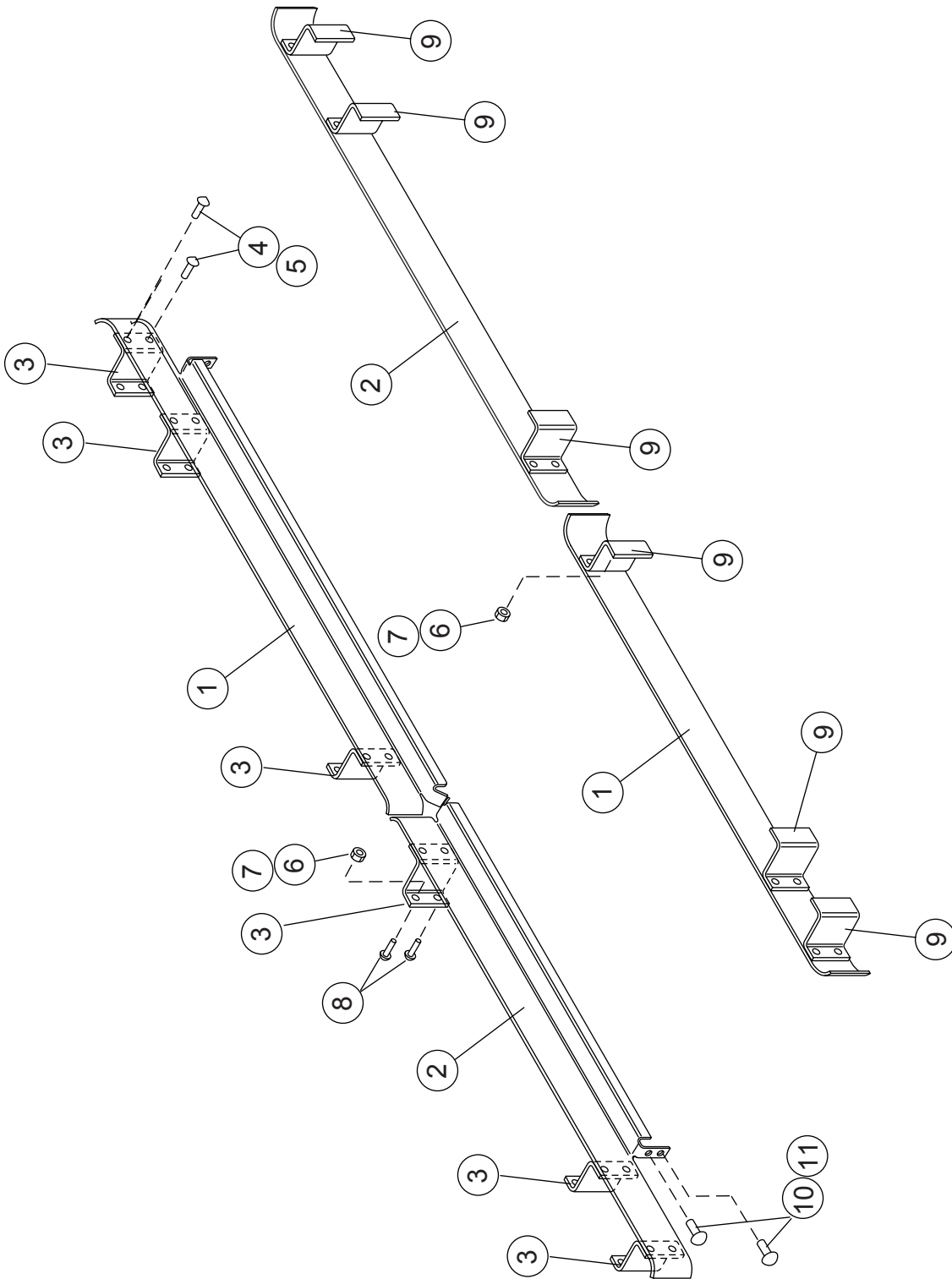

**Figure 6.4 -
Track Assembly
(R-L machine shown)**

**TRACK ASSEMBLY
(R-L MACHINE SHOWN)**

Fig. 6.4 Item No.	Part No.	Part Description	Qty.
1	322865	Track..... (RHR for R-L machine) (LHF for R-L machine) (RHF for L-R machine) (LHR for L-R machine)	2
2	322866	Track..... (LHR for R-L machine) (RHF for R-L machine) (RHR for L-R machine) (LHF for L-R machine)	2
3	322889	Bracket, rear track	6
4	111296	Screw, undercut, 10-32 x 3/8"	24
5	104985	Nut, hex 10-32	24
6	106482	Washer, lock 1/4"	24
7	100003	Nut, hex 1/4-20	24
8	112318	Screw, 1/4-20 x 1/2"	12
9	322890	Bracket, front track	6
10	100141	Nut, grip 1/4-20	8
11	100073	Screw, 1/4-20 x 1/2"	8

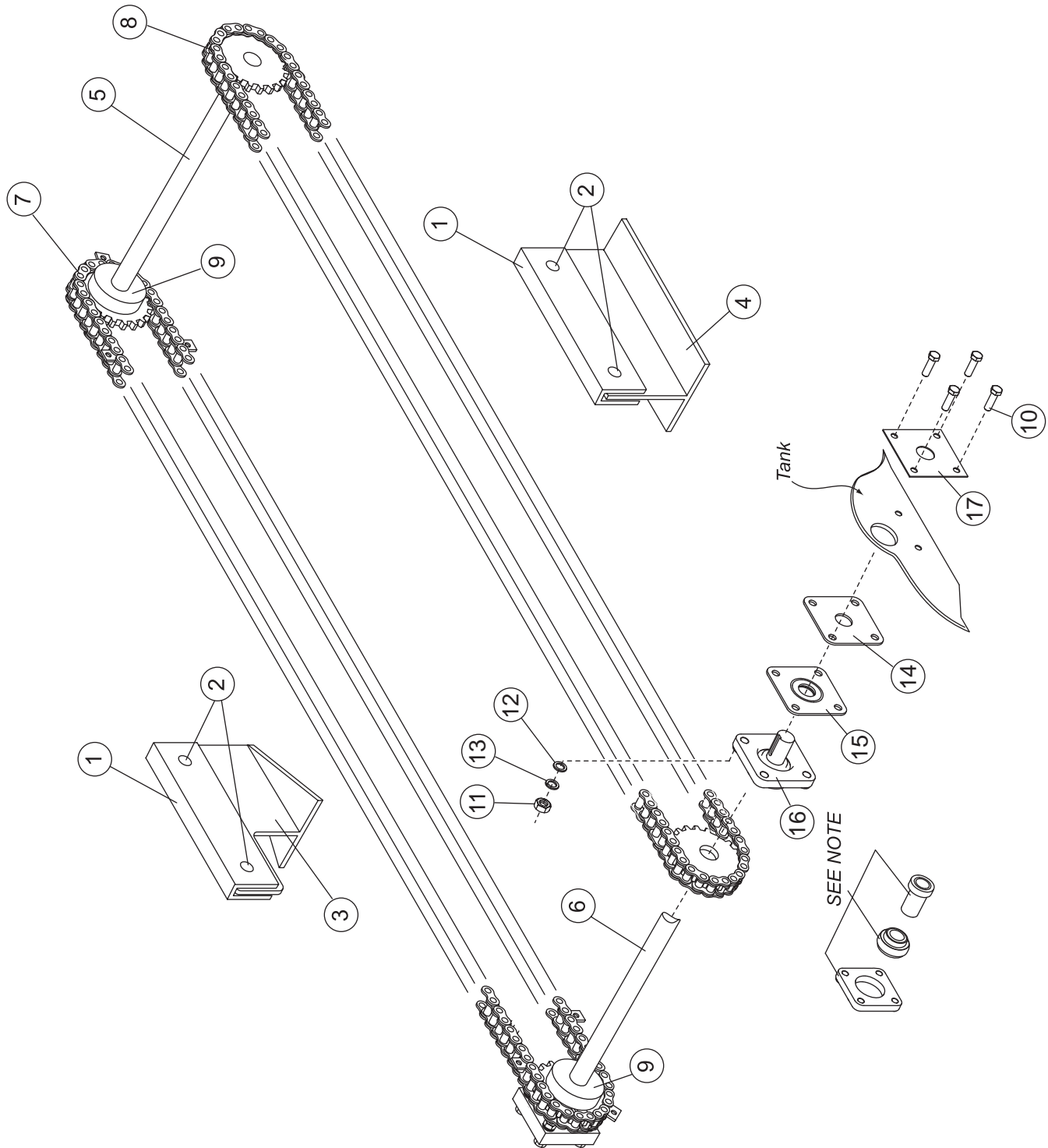

Figure 6.5 -
Conveyor shafts, chains, bearings, and guides
(S/N 90922 through J1050)

CONVEYOR SHAFTS, CHAINS, BEARINGS, AND GUIDES

(S/N 90922 through S/N J1050)

Fig. 6.5 Item No.	Part No.	Part Description	Qty.
1	106354	Guide, delrin	2
2	107245	Pin, roll 1/8" SST	4
3	322988	Bracket, chain guide rear	1
4	322987	Bracket, chain guide front	1
5	112775	Shaft, take-up	1
6	112774	Shaft, drive	1
7	112610	Chain, rear w/lugs	1
8	112611	Chain, front	1
9	112597	Sprocket, conveyor 1" bore w/set screw	4
10	111201	Bolt, 3/8-16 x 1-1/4".....	8
11	100143	Nut, 3/8-16.....	8
12	104618	Washer, flat 3/8"	8
13	106407	Washer, lock 3/8"	8
14	114586	Gasket, 3-3/4" x 3-3/4" 4 Bolt with 1" hole.....	1
15	418379	Bearing Seal and Plate Assy.	1
16	114292	Bearing Assembly	4
17	325360	Filler Plate	1
—	113192	Master Link (not shown)	2
—	113193	Offset Link (not shown)	2
—	900918	Bearing, Seal and Gasket Kit (Includes Items 14-16)	A/R

NOTE: Any machine manufactured using a polyethylene bearing, housing or sleeve design (as shown) will require a Kit P/N 900918 in order to make a repair.

The old component design is no longer available.

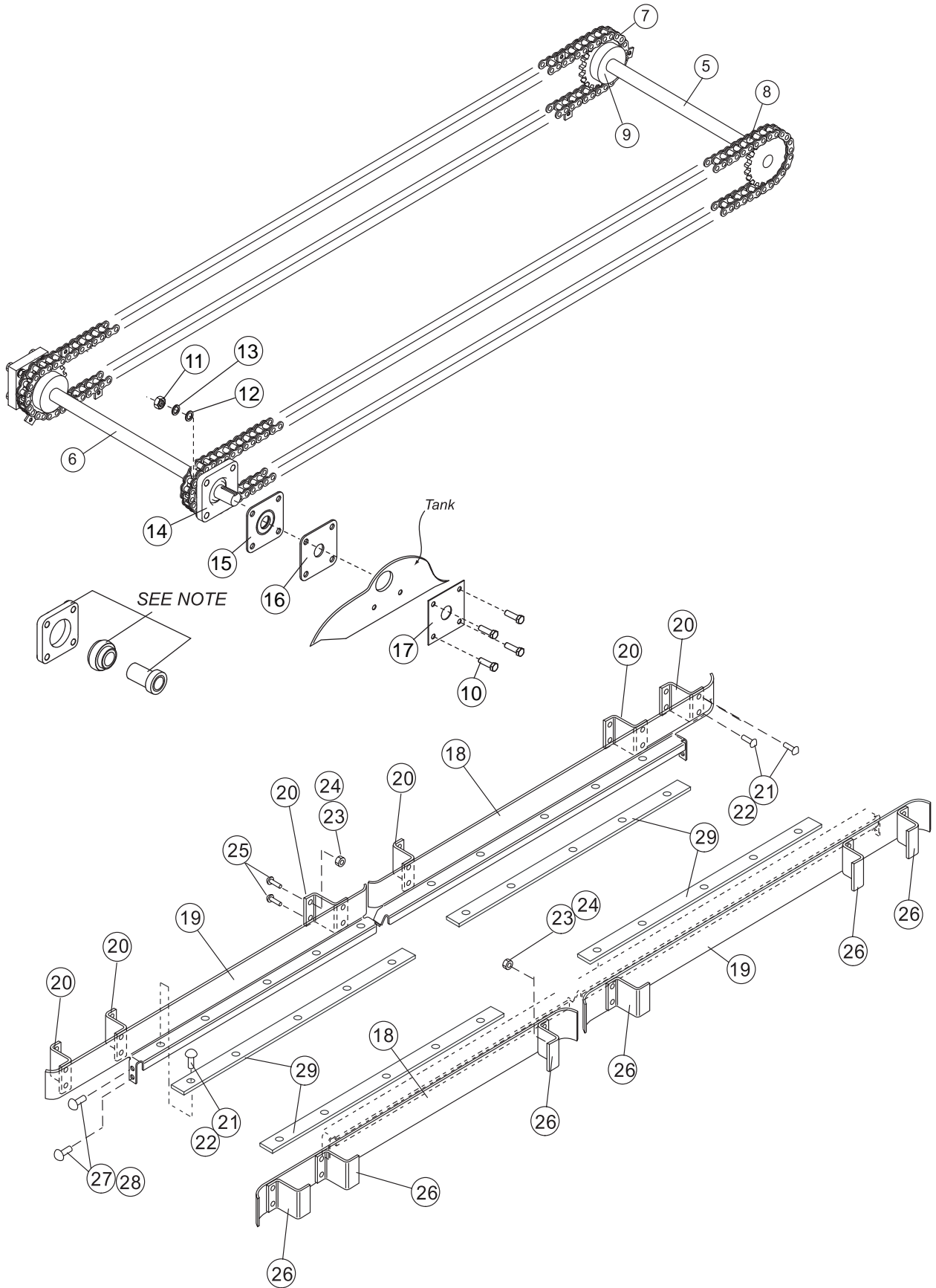

Figure 6.5a -
Conveyor shafts, chains, bearings and guides
(From S/N J1050 and Above)

CONVEYOR SHAFTS, CHAINS, BEARINGS, AND GUIDES

(From S/N J1050 and Above)

Fig. 6.5a Item No.	Part No.	Part Description	Qty.
1	106354	Guide, delrin	2
2	107245	Pin, roll 1/8" SST	4
3	322988	Bracket, chain guide rear	1
4	322987	Bracket, chain guide front	1
5	113180	Shaft, take-up	1
6	112774	Shaft, drive	1
7	112610	Chain, rear w/lugs	1
8	112611	Chain, front	1
9	112597	Sprocket, conveyor 1" bore w/set screw	4
10	111201	Bolt , 3/8-16 x 1-1/4".....	8
11	100143	Nut , 3/8-16.....	8
12	104618	Washer, flat 3/8"	8
13	106407	Washer, lock 3/8"	8
14	114586	Gasket, 3-3/4" x 3-3/4" 4 Bolt with 1" hole.....	1
15	418379	Bearing Seal and Plate Assy.	1
16	114292	Bearing Assembly	4
17	325360	Filler Plate	1
—	113192	Master Link (not shown)	2
—	113193	Offset Link (not shown)	2
—	900918	Bearing, Seal and Gasket Kit (Includes Items 14-16)	A/R
18	322865	Track..... (RHR for R-L machine) (RHF for L-R machine) (LHF for R-L machine) (LHR for L-R machine)	2
19	322866	Track..... (LHR for R-L machine) (RHR for L-R machine) (RHF for R-L machine) (LHF for L-R machine)	2
20	322889	Bracket, rear track	6
21	111296	Screw, undercut, 10-32 x 3/8"	44
22	104985	Nut, hex 10-32	44
23	106482	Washer, lock 1/4"	24
24	100003	Nut, hex 1/4-20.....	24
25	112318	Screw, 1/4-20 x 1/2"	12
26	322890	Bracket, front track.....	6
27	100141	Nut, grip 1/4-20	8
28	100073	Screw, 1/4-20 x 1/2"	8
29	113212	Strip, guide	4

NOTE: Any machine manufactured using a polyethylene bearing, housing or sleeve design (as shown) will require a Kit P/N 900918 in order to make a repair. The old component design is no longer available.

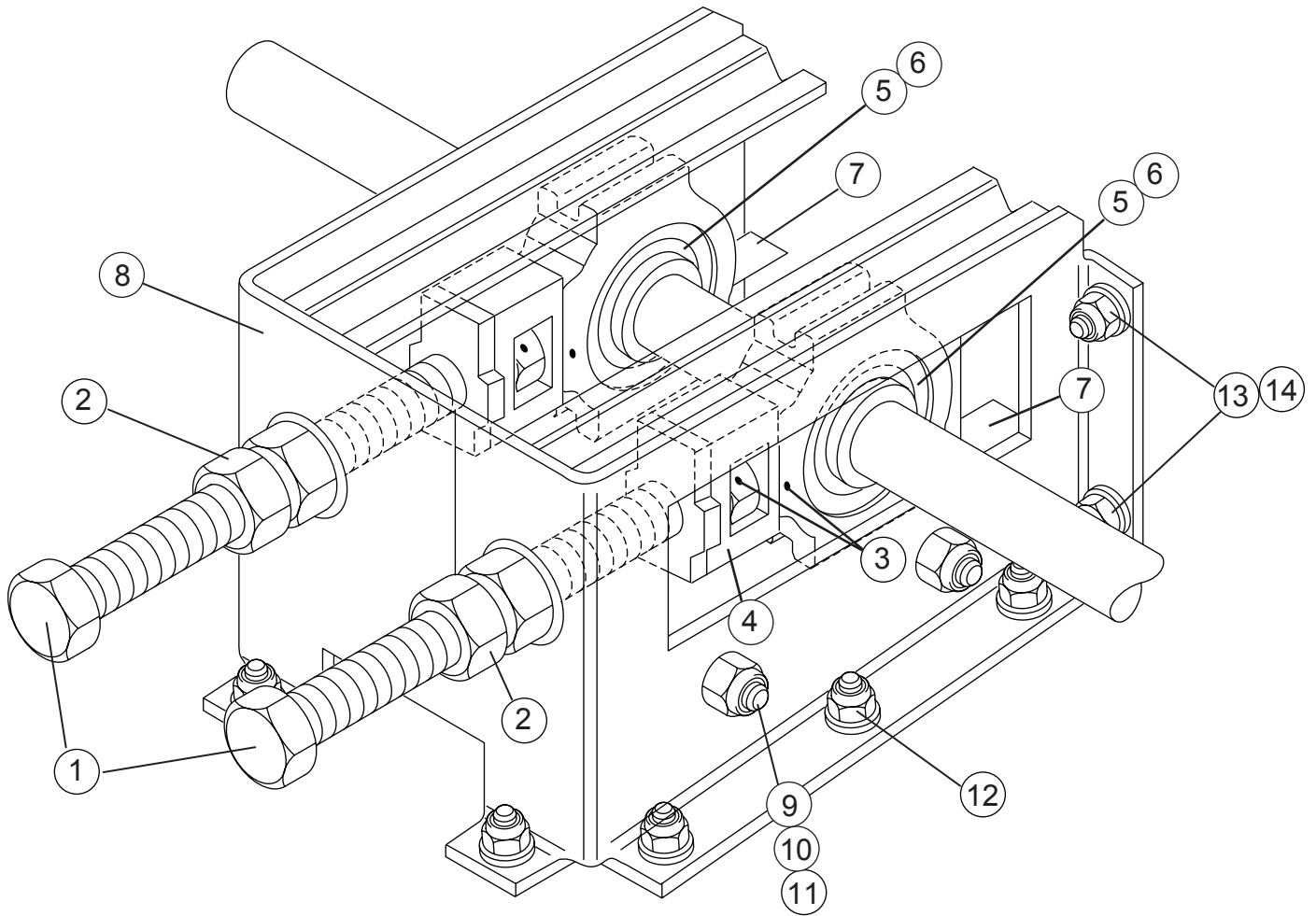

**Figure 6.6 -
Conveyor chain take-up assembly
(For machines built prior to S/N J1050)**

CONVEYOR CHAIN TAKE-UP ASSEMBLY
(For machines built prior to S/N J1050)

Fig. 6.6 Item No.	Part No.	Part Description	Qty.
1	309397	Rod, 5/8-11 x 6"	2
2	107691	Nut, 5/8-11 hex hd	6
3	111082	Pin, roll, 3/16" x 7/8"	4
4	323052	Adaptor, take-up bearing	2
5	112707	Housing, bearing	2
5	112599	Housing, bearing (effective 2/23/2000)	2
**6	112598	Bearing	2
---	900841	Kit*Bearing/Sleeve USN72	2
7	309386	Track, take-up bearing	2
8	323231	Housing, take-up	1
9	100739	Screw, 5/16-18 x 3/4"	4
10	106013	Washer, lock 5/16"	4
11	109009	Nut, lock 5/16-18	4
12	107967	Nut, lock 1/4-20	8
13	112318	Screw, 1/4-20 hex hd	4
14	100003	Nut, hex 1/4-20	4

** Effective 2/23/00 part number 112598 has been replaced by 900841 Kit*Bearing/
Sleeve. These bearings and sleeves will fit in housing part number 112707.
If part number 112707 needs to be replaced then we suggest you use the following:

--- 900838 Kit* bearing replacement (includes items 5 and item 6).

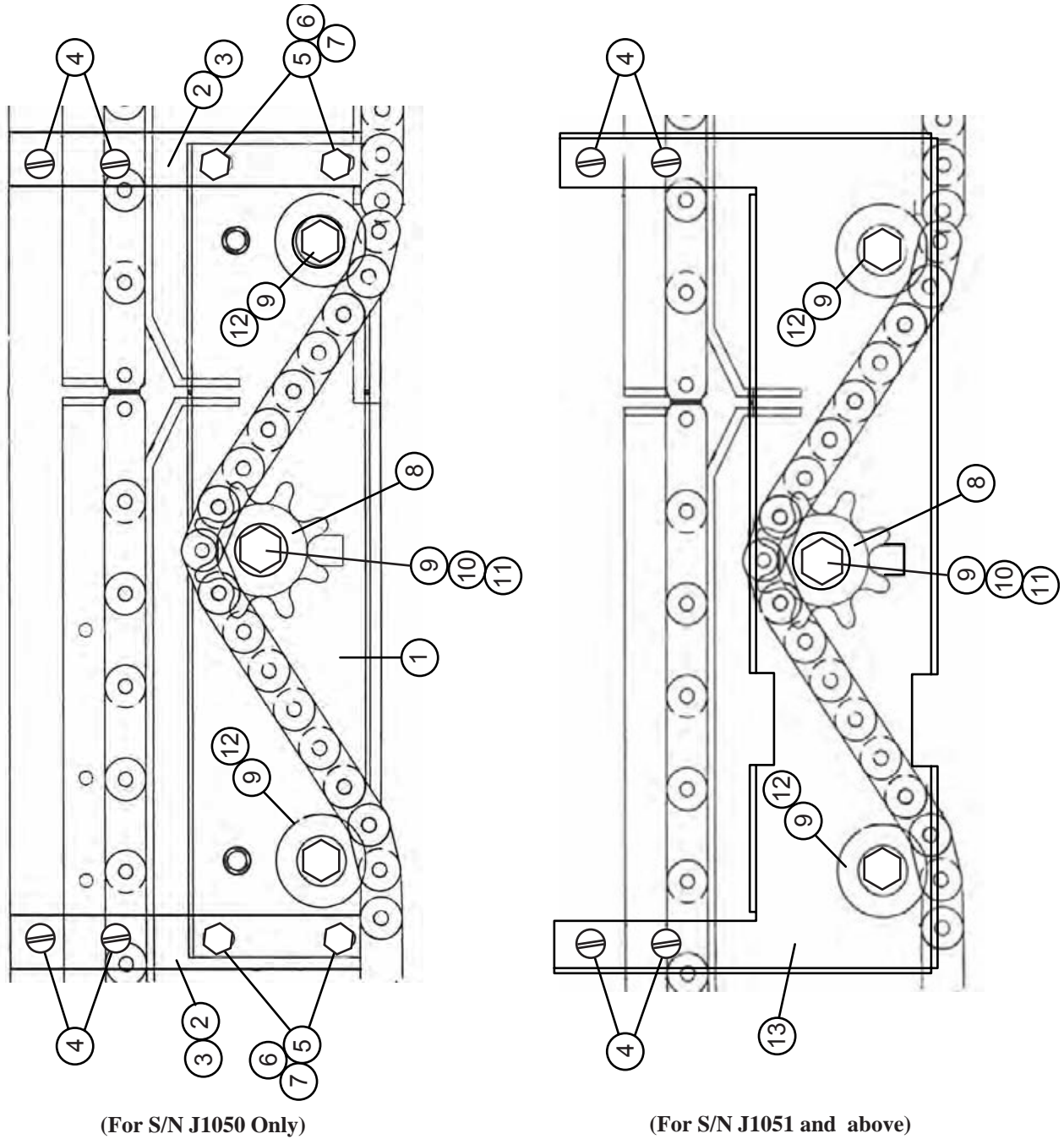
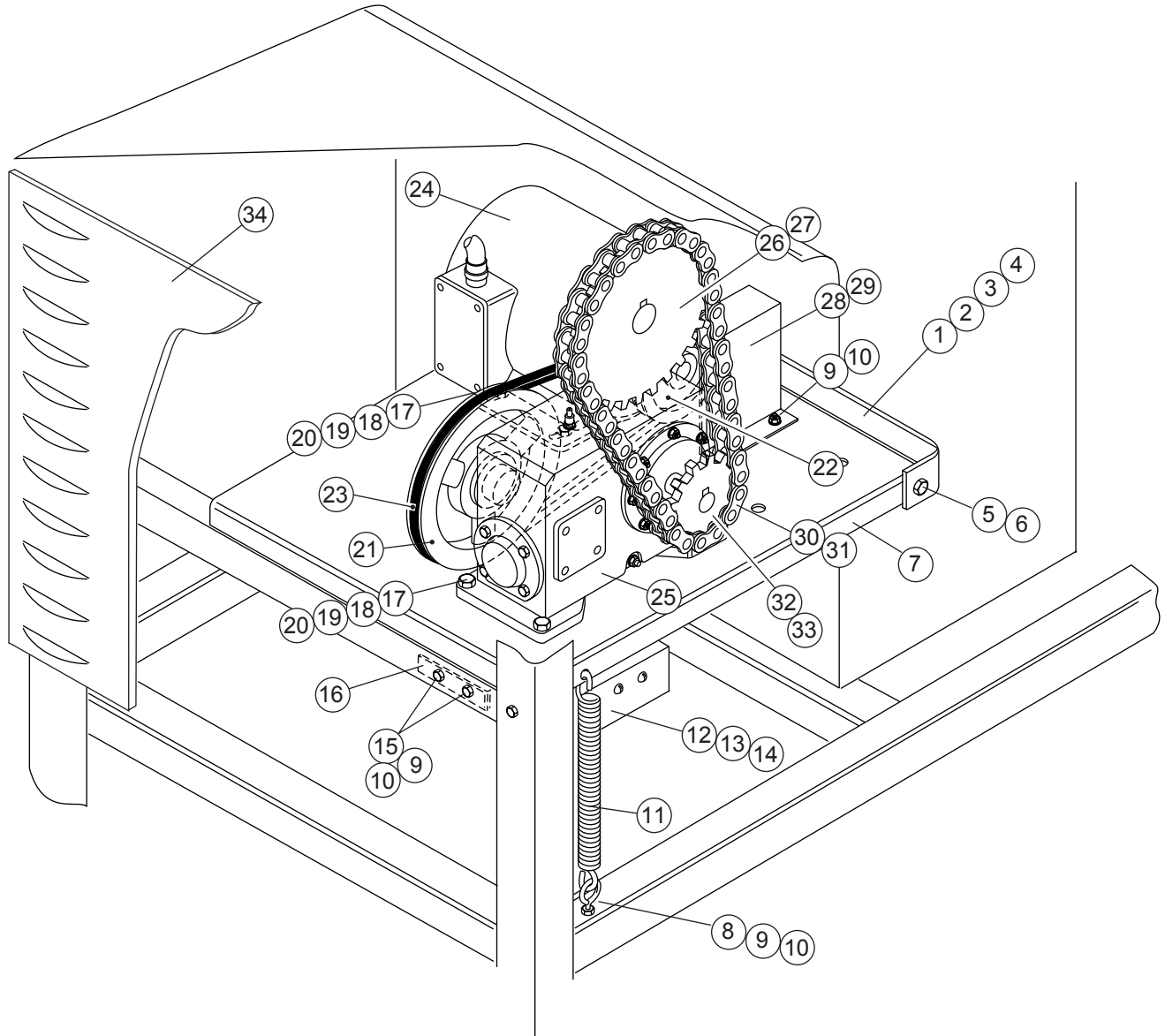

Figure 6.6a -
Conveyor chain take-up assembly
(For machines beginning with S/N J1050 and above)

CONVEYOR CHAIN TAKE-UP ASSEMBLY
(For machines beginning with S/N J1050 and above)

Fig. 6.6a Item No.	Part No.	Part Description	Qty.
1	325374	Chain tensioner.....	2
2	324328	Support, rear chain tensioner.....	2
3	325376	Support, front chain tensioner.....	2
4	100754	Screw (10-32 x 1/2"), slot flat.....	8
5	100735	Screw (1/4-20 x 3/4"), hex cap.....	8
6	106026	Washer, flat.....	8
7	106482	Washer, lock.....	8
8	205971	Sprocket, chain tensioner.....	2
9	113014	Bolt (3/8-16 x 1.5"), shoulder with hex socket.....	6
10	325373	Shim, tensioner.....	2
11	205969	T-nut (5/16-18).....	2
12	205970	Roller, chain tensioner.....	4
13	325567	Bracket, chain tensioner (Single Piece construction).....	1



**Figure 6.7 -
Conveyor drive assembly**

CONVEYOR DRIVE ASSEMBLY

Fig. 6.7 Item No.	Part No.	Part Description	Qty.
1	322737	Bracket, drive base	1
2	100073	Screw, 1/4-20 x 1/2"	4
3	100141	Nut, grip, 1/4-20	4
4	106026	Washer, flat 1/4"	4
5	100153	Bolt, 3/8-16 x 1" hex hd	2
6	100143	Nut, grip 3/8-16	2
7	322736	Base, drive	1
8	111095	Eyebolt, 1/4-20 x 1"	1
9	100141	Nut, 1/4-20 hex hd	6
10	106482	Washer, lock 1/4"	5
11	112709	Spring, extension	1
12	100352	Switch, micro	1
13	0508751	Screw, 10-32 x 1 1/2"	2
14	107966	Nut, lock 10-32	2
15	100738	Bolt, 1/4-20 x 1"	2
16	112701	Bracket, switch	1
17	100740	Screw, 5/16-18 x 1"	10
18	102376	Washer, flat 5/16"	10
19	106013	Washer, lock 5/16"	6
20	100154	Nut, 5/16-18 hex hd	6

RPM ▼	Item No. 21	Item No. 22	Item No. 23	Item No. 26	Item No. 32
Name ▶	<i>Sheave, Reducer</i>	<i>Sheave, Motor</i>	<i>V-Belt</i>	<i>Sprocket, Drive</i>	<i>Sprocket, Reducer</i>
250	P/N 112713 AK30	P/N 103162 AK25	P/N 100793 4L300	P/N 112609 50B23	P/N 113397 50B15
185	P/N 112603 AK41	P/N 103162 AK25	P/N 100795 4L320	P/N 112609 50B23	P/N 113397 50B15
135	P/N 113404 AK49	P/N 100442 AK22	P/N 100795 4L320	P/N 112609 50B23	P/N 113397 50B23
85	P/N 112604 AK56	P/N 113623 AK26	P/N 100799 4L350	P/N 112609 50B23	P/N 110164 50B11
60	P/N 112604 AK56	P/N 113067 AK20	P/N 100796 4L330	P/N 112609 50B23	P/N 112609 50B11

24	112590	Motor, drive 1/4 hp 440V/60/3ph	1
25	113398	Reducer, gear (L-R machine)	1
	113399	Reducer, gear (R-L machine)	1
27	108147	Key, 1/4" x 1/4" x 1 1/4"	1
28	322898	Guard, belt (R-L machine)	1
29	–	Guard, belt (L-R machine)	1
30	101149	Link, Master #50	1
31	112785	Chain, #50	A/R
33	104915	Key, 3/16" x 3/16" x 1 1/4"	1
34	325344	Panel, louvered end	1

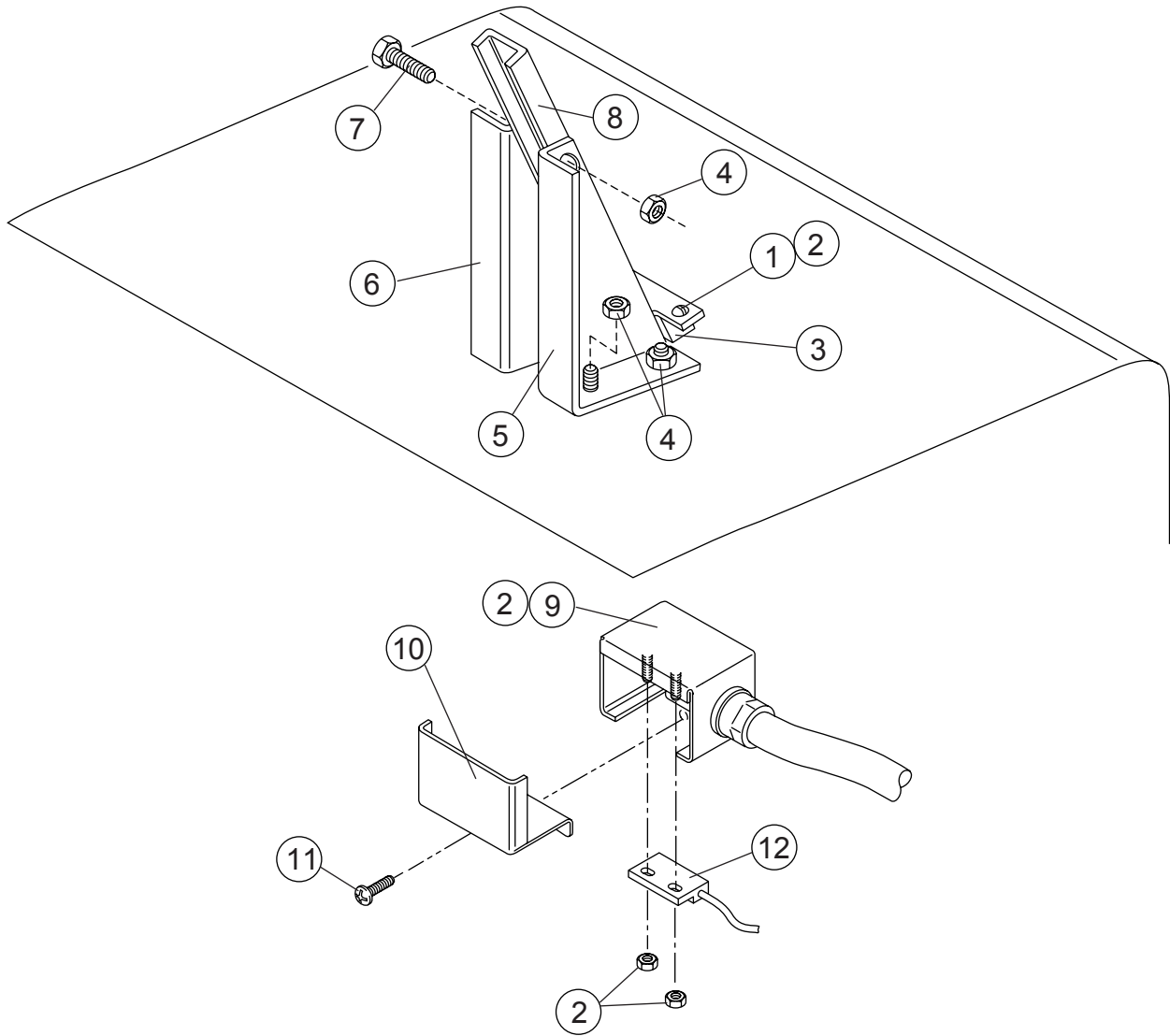

**Figure 6.8 -
Rinse saver assembly**

RINSE SAVER ASSEMBLY

Fig. 6.8 Item No.	Part No.	Part Description	Qty.
1	106382	Screw, 6-32 x 3/8"	2
2	108954	Nut, 6-32	8
3	111026	Magnet	1
4	107967	Nut, lock 1/4-20	5
5	322920-2	Side, rinse paddle bracket	1
6	322920-1	Side, rinse paddle bracket	1
7	106472	Screw, 1/4-20 x 1 1/4"	1
8	322919	Paddle, rinse assembly	1
9	322891	Box, switch	1
10	322892	Cover, switch box	1
11	100007	Screw, 10-32 x 3/8"	1
12	112659	Switch, magnetic reed	1

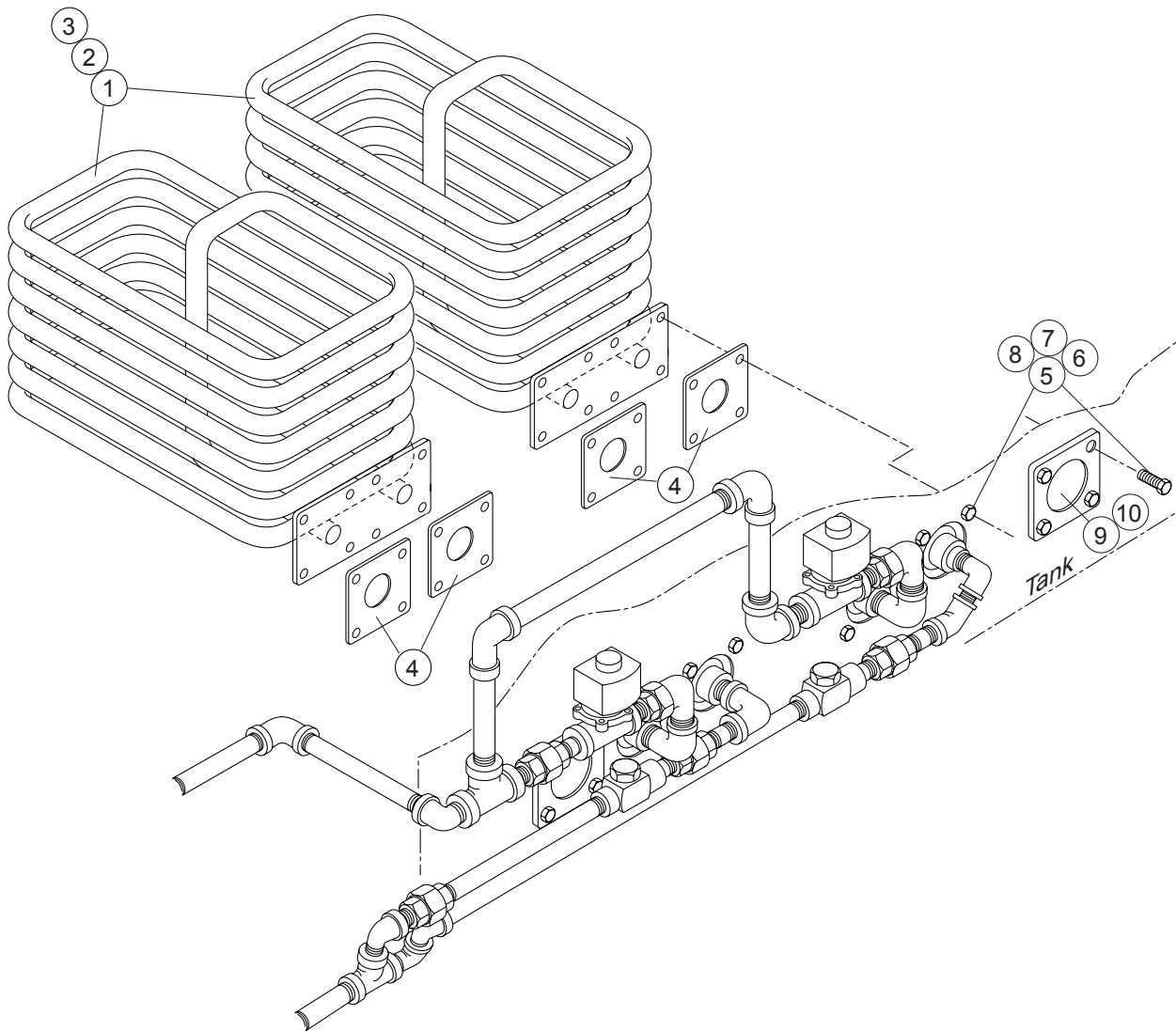

Figure 6.9-
Steam coil assembly

STEAM COIL ASSEMBLY

Fig. 6.9 Item No.	Part No.	Part Description	Qty.
1	323235	Coil steam (1 per tank)	1
2	B2850-1	Bracket, coil	1
3	B2850-2	Bracket, coil	1
4	108345	Gasket (2 per coil)	2
5	100740	Bolt, 5/16-18 x 1"	24
6	102376	Washer, flat 5/16"	48
7	106013	Washer, lock 5/16"	24
8	100154	Nut, 5/16-18 hex hd.....	24
9	109683	Plate, block-off	2
10	112257	O-ring	2

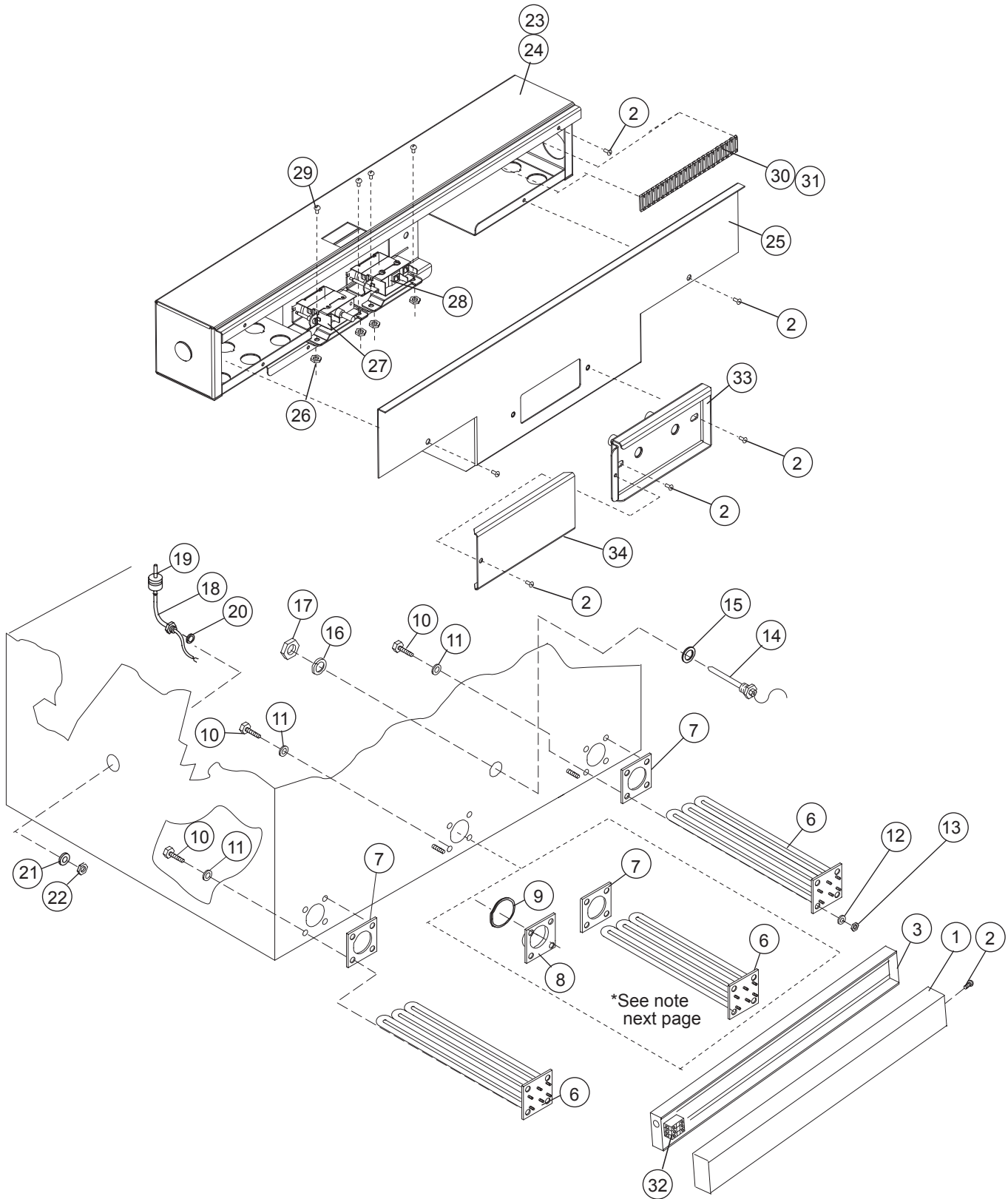

Figure 6.9a -
Electric Tank Heat
(For machines beginning with S/N J1050 through J1871)
Left-Right Installation Shown

ELECTRIC TANK HEAT
(For machines beginning with S/N J1050 through J1871)

Fig. 6.9a Item No.	Part No.	Part Description	Qty.
1	317165	Cover, heater box, metal	2
2	100007	Screw (10-32 x 3/8").....	8
3	317166	Heater box, metal	2
4	107033	Washer, flat	16
5	107967	Nut (1/4-20), grip with nylon insert	16
*6	107846	Heater Element-10KW (480V)	A/R
7	108345	Gasket, heater	5
8	109638	Flange, blockoff	1
9	112257	O-ring	1
10	100740	Bolt (5/16-18 x 1"), hex cap	24
11	102376	Washer, flat (5/16")	48
12	106013	Washer, lock (5/16") medium split	24
13	100154	Nut (5/16-18), hex finish	24
14	109069	Thermostat, with capillary	1
15	201041	Washer, flat (7/8" ID x 1/8")	1
16	109034	Gasket (1/2 NPT) plug	1
17	100547	Locknut (1 1/2 NPT)	1
18	111092	Switch, float	1
19	111151	C-clip	2
20	110750	Gasket, float switch	1
21	107589	Washer, lock (1/2")	1
22	104584	Nut, plain (1/2-13).....	1
23	328193	Wireway box, RH.....	1
24	328194	Wireway box, LH.....	1
25	328190	Wireway cover	2
26	108954	Nut (6-32), w/nylon insert.....	4
27	110561	Thermostat, high limit with reset	2
28	109069	Thermostat, with capillary	2
29	106382	Screw (6-32 x 3/8"), slot truss	4
30	113777	Block, Terminal, 18-Pole, Wash Tank.....	1
31	113778	Block, Terminal, 26-Pole, Rinse Tank.....	1
32	111833	Block, Terminal, 3P 175A	2
33	332634	Weldment, Thermostat Adjustment Guide	1
34	332635	Plate, Cover, Thermostat Adjustment	1

*Note:

Install Qty.1, P/N 109638, Flange Block-off and Qty.1 P/N 112257, O-ring in place of heater element.

Wash Tank Heat installations use Qty.2, P/N 107846 10kW heaters.

Rinse Tank Heat installations use Qty.3, P/N 107846 10kW heaters.

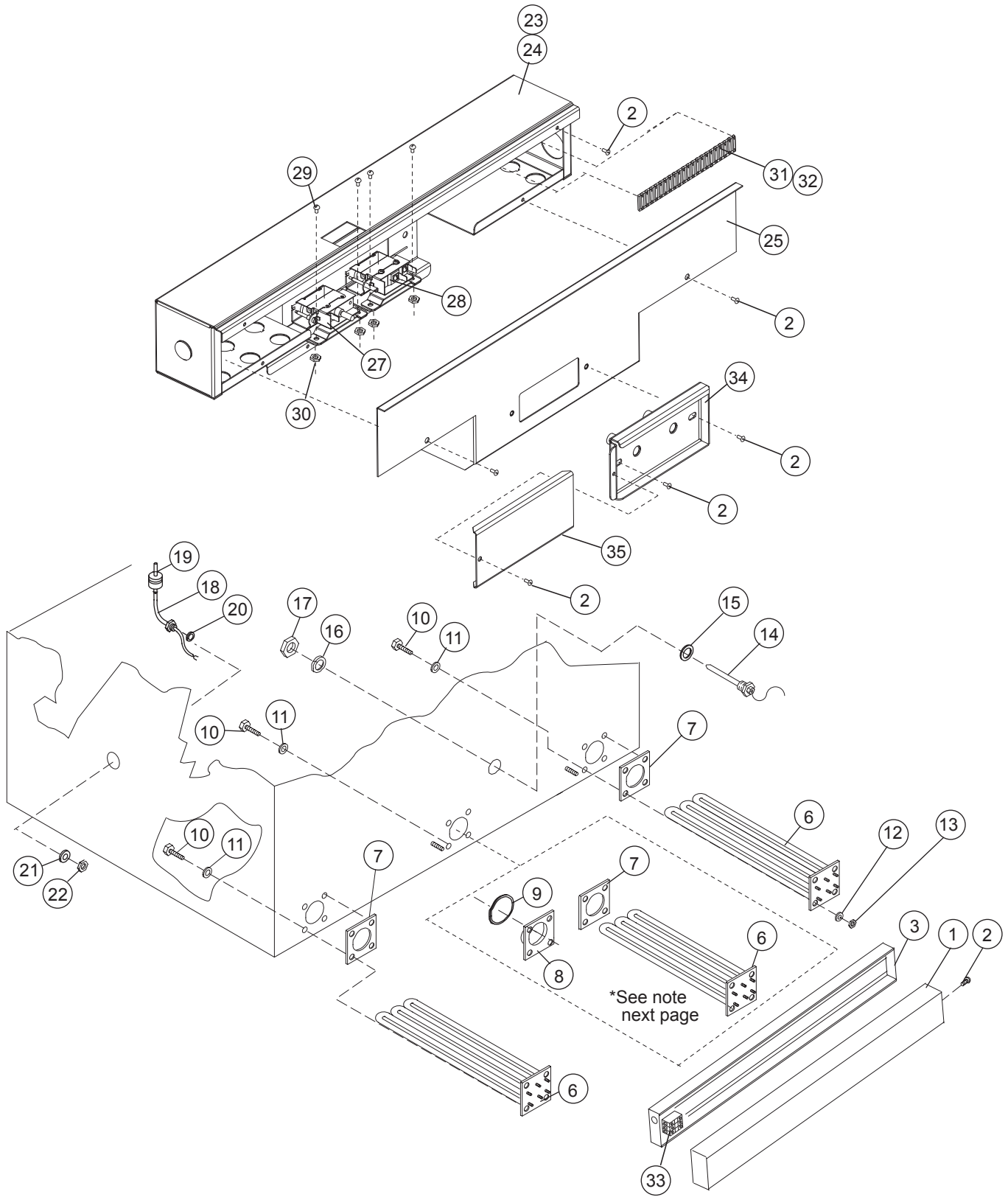

**Figure 6.9b -
Electric Tank Heat**
(For machines beginning with S/N J1872 and above)
Left-Right Installation Shown

ELECTRIC TANK HEAT
(For machines beginning with S/N J1872 and above)

Fig. 6.9b Item No.	Part No.	Part Description	Qty.
1	317165	Cover, heater box, metal	2
2	100007	Screw (10-32 x 3/8").....	8
3	317166	Heater box, metal	2
4	107033	Washer, flat	16
5	107967	Nut (1/4-20), grip with nylon insert	16
*6	107846	Heater Element-10KW (480V)	A/R
7	108345	Gasket, heater	5
8	109638	Flange, blockoff	1
9	112257	O-ring	1
10	100740	Bolt (5/16-18 x 1"), hex cap	24
11	102376	Washer, flat (5/16")	48
12	106013	Washer, lock (5/16") medium split	24
13	100154	Nut (5/16-18), hex finish	24
14	109069	Thermostat, with capillary	1
15	201041	Washer, flat (7/8" ID x 1/8")	1
16	109034	Gasket (1/2 NPT) plug	1
17	100547	Locknut (1 1/2 NPT)	1
18	111092	Switch, float	1
19	111151	C-clip	2
20	110750	Gasket, float switch	1
21	107589	Washer, lock (1/2")	1
22	104584	Nut, plain (1/2-13)	1
23	328193	Wireway box, RH.....	1
24	328194	Wireway box, LH.....	1
25	328190	Wireway cover	2
26	108954	Nut (6-32), w/nylon insert.....	4
27	110561	Thermostat, high limit with reset	2
28	109069	Thermostat, with capillary	2
29	106382	Screw (6-32 x 3/8"), slot truss.....	4
30	113777	Block, Terminal, 18-Pole, Wash Tank.....	1
31	113778	Block, Terminal, 26-Pole, Rinse Tank.....	1
32	111833	Block, Terminal, 3P 175A	2
33	332634	Weldment, Thermostat Adjustment Guide	1
34	332635	Plate, Cover, Thermostat Adjustment	1

*Note:

Install Qty.1, P/N 109638, Flange Block-off and Qty.1 P/N 112257, O-ring in place of heater element.

Wash Tank Heat installations use Qty.2, P/N 107846 10kW heaters.

Rinse Tank Heat installations use Qty.3, P/N 107846 10kW heaters.

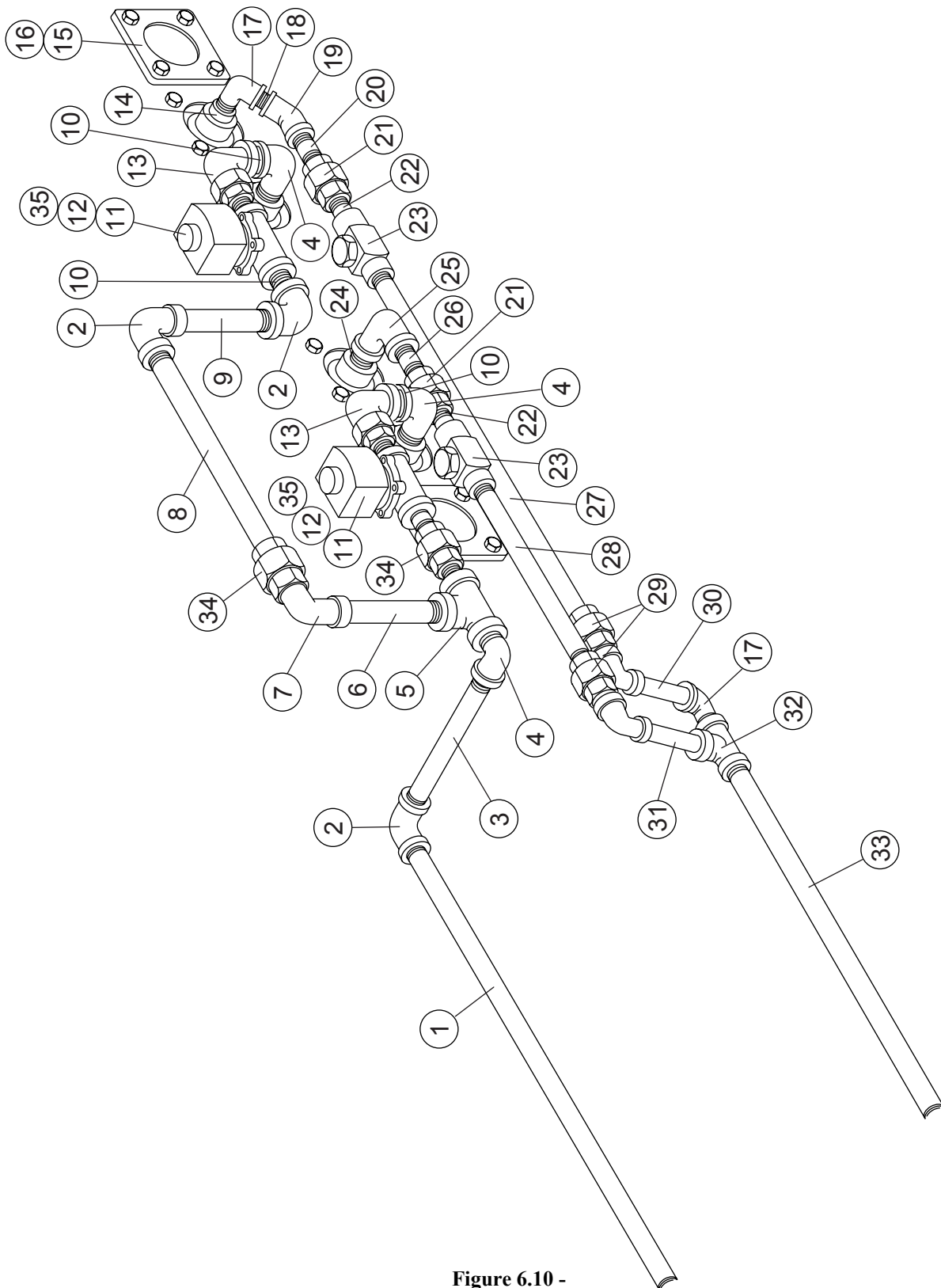

Figure 6.10 -
Tank steam piping with booster
(R-L machine shown)

**TANK STEAM PIPING WITH BOOSTER
(R-L MACHINE SHOWN)**

Fig. 6.10 Item No.	Part No.	Part Description	Qty.
1	Coml	Nipple, 3/4 NPT x 16, brass	1
2	Coml	Elbow, 3/4" NPT, brass	3
3	Coml	Nipple, 3/4" NPT x 7 1/2",brass	1
4	Coml	Street elbow, 3/4" NPT, brass	3
5	Coml	Tee, 3/4" NPT, brass	1
6	Coml	Nipple, 3/4" NPT x 5", brass	1
7	Coml	Union elbow, 3/4" NPT , female, brass	1
8	Coml	Nipple, 3/4" NPT x 10 1/2",brass	1
9	Coml	Nipple, 3/4" NPT x 5", brass	1
10	Coml	Nipple, close, 3/4" NPT, brass	5
11	109887	Valve solenoid steam 3/4" NPT	2
12	109903	Repair kit steam valve, 3/4"	
13	Coml	Union elbow, 3/4" NPT, male, brass	2
14	Coml	Bushing, reducing, 3/4" x 1/2", brass	1
15	109683	Flange block off	2
16	112257	O-ring	2
17	Coml	Street elbow, 1/2" NPT, brass	2
18	Coml	Nipple, close, 1/2" NPT, brass	1
19	Coml	Elbow, 45°, 1/2", brass	1
20	Coml	Nipple, 1/2" x 2", brass	1
21	Coml	Union, 1/2" NPT, brass	2
22	Coml	Nipple, close, 1/2", brass	2
23	111380	Steam trap, thermodynamic 1/2" SST	2
24	Coml	Nipple, 3/4" x 2", brasss	1
25	Coml	Elbow reducing, 3/4" x 1/2", 90°, brass	1
26	Coml	Nipple, 1/2" NPT x 4" long, brass	1
27	Coml	Nipple, 1/2" NPT x 19" long, brass	1
28	Coml	Nipple, 1/2" NPT x 10 1/4" long, brass	1
29	Coml	Union elbow, female, 1/2" NPT, brass	2
30	Coml	Nipple, 1/2" NPT x 3 3/4", brass	1
31	Coml	Nipple, 1/2" NPT x 5 1/2", brass	1
32	Coml	Tee reducing, 3/4" x 1/2" x 1/2", brass	1
33	Coml	Nipple, 3/4" NPT x 12" long, brass	1
34	Coml	Union, 3/4" NPT, brass	1
35	108516	Coil, solenoid valve, 3/4" 120v	1

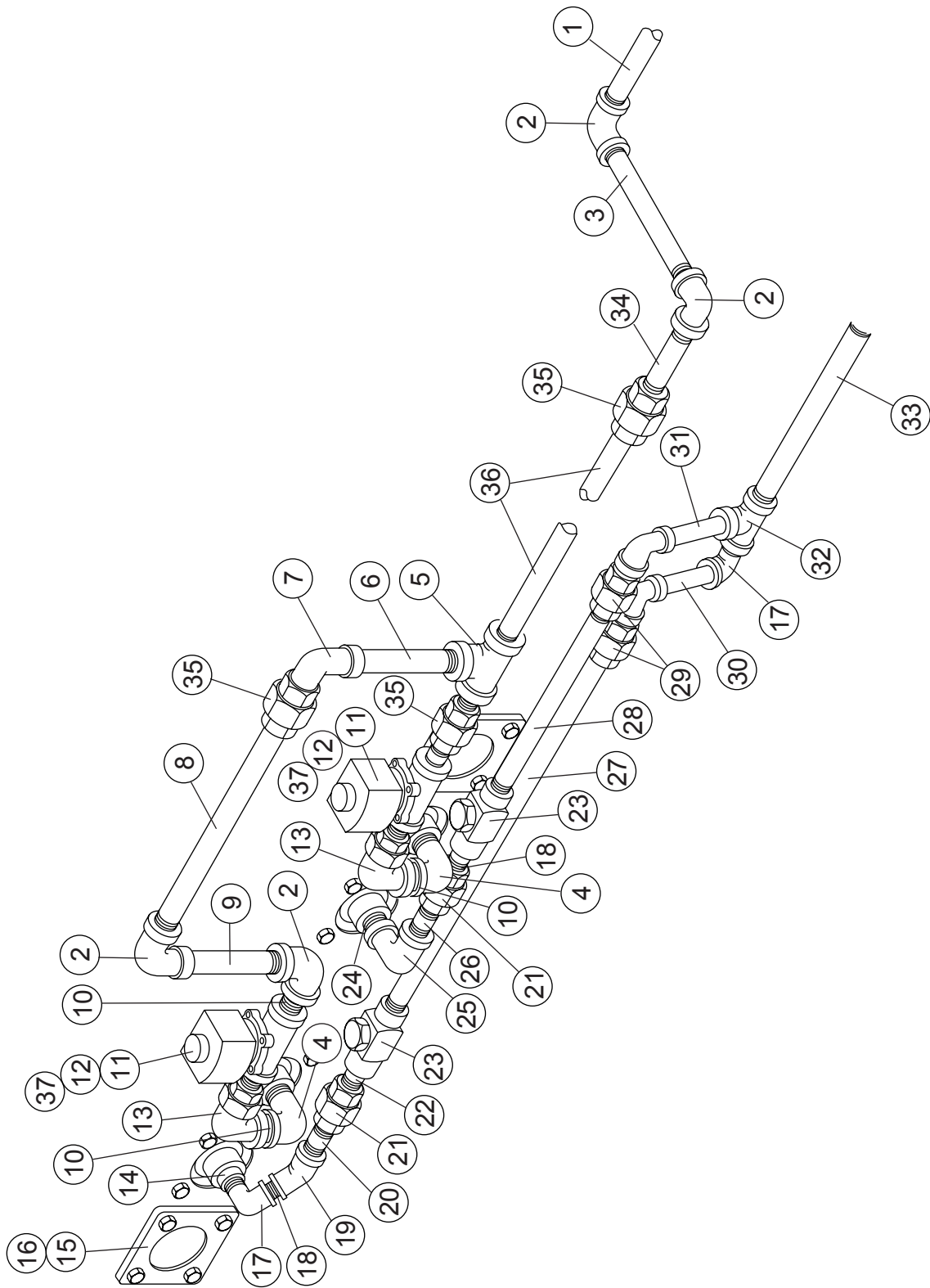

Figure 6.11 -
Tank steam piping with booster
(L-R machine shown)

**TANK STEAM PIPING WITH BOOSTER
(L-R MACHINE SHOWN)**

Fig. 6.11 Item No.	Part No.	Part Description	Qty.
1	Coml	Nipple, 3/4" NPT x 8-1/2" long, brass	1
2	Coml	Elbow, 3/4" NPT, brass	4
3	Coml	Nipple, 3/4"NPT x 8-1/2" long, brass	1
4	Coml	Street ell, 3/4" NPT, brass	2
5	Coml	Tee, 3/4" NPT, brass	1
6	Coml	Nipple, 3/4" NPT x 5" long, brass	1
7	Coml	Union ell, female, 3/4" NPT, brass	1
8	Coml	Nipple, 3/4" NPT x 9-1/4" long, brass	1
9	Coml	Nipple, 3/4" NPT x 5" long, brass	1
10	Coml	Nipple close, 3/4" NPT, brass.....	5
11	109887	Valve solenoid steam, 3/4" NPT	2
12	109903	Repair kit steam valve, 3/4"	
13	Coml	Union ell, male, 3/4" NPT, brass	2
14	Coml	Bushing reducing, 3/4" x 1/2" NPT, brass	1
15	109683	Flange, blockoff	2
16	112257	O-ring, flange blockoff.....	2
17	Coml	Street ell, 1/2" NPT, brass.....	2
18	Coml	Nipple close, 1/2" NPT, brass.....	1
19	Coml	Elbow, 45°, 1/2" NPT, brass	1
20	Coml	Nipple close, 1/2" NPT, brass	1
21	Coml	Union, 1/2" NPT, brass	2
22	Coml	Nipple, 1/2" NPT x 4" lg., brass	1
23	111380	Steam trap, thermodynamic, 1/2" NPT, SST	2
24	Coml	Nipple close, 3/4" NPT, brass	1
25	Coml	Elbow reducing, 3/4" x 1/2" NPT, brass	1
26	Coml	Nipple close, 1/2", brass.....	1
27	Coml	Nipple, 1/2" NPT x 13-3/4" lg., brass	1
28	Coml	Nipple, 1/2" NPT x 9" lg., brass	1
29	Coml	Union ell, female, 1/2", brass	2
30	Coml	Nipple, 1/2" NPT x 4-3/4" lg., brass	1
31	Coml	Nipple, 1/2" NPT x 5-3/4" lg., brass	1
32	Coml	Tee reducing, 3/4" x 1/2" x 1/2" NPT, brass.....	1
33	Coml	Nipple, 3/4" NPT x 12" lg., brass	1
34	Coml	Nipple, 3/4" NPT x 7-1/2" lg., brass	1
35	Coml	Union, 3/4", brass	1
36	Coml	Nipple, 3/4" x 23" lg., brass	1
37	108516	Coil, solenoid valve, 3/4" 120V	1

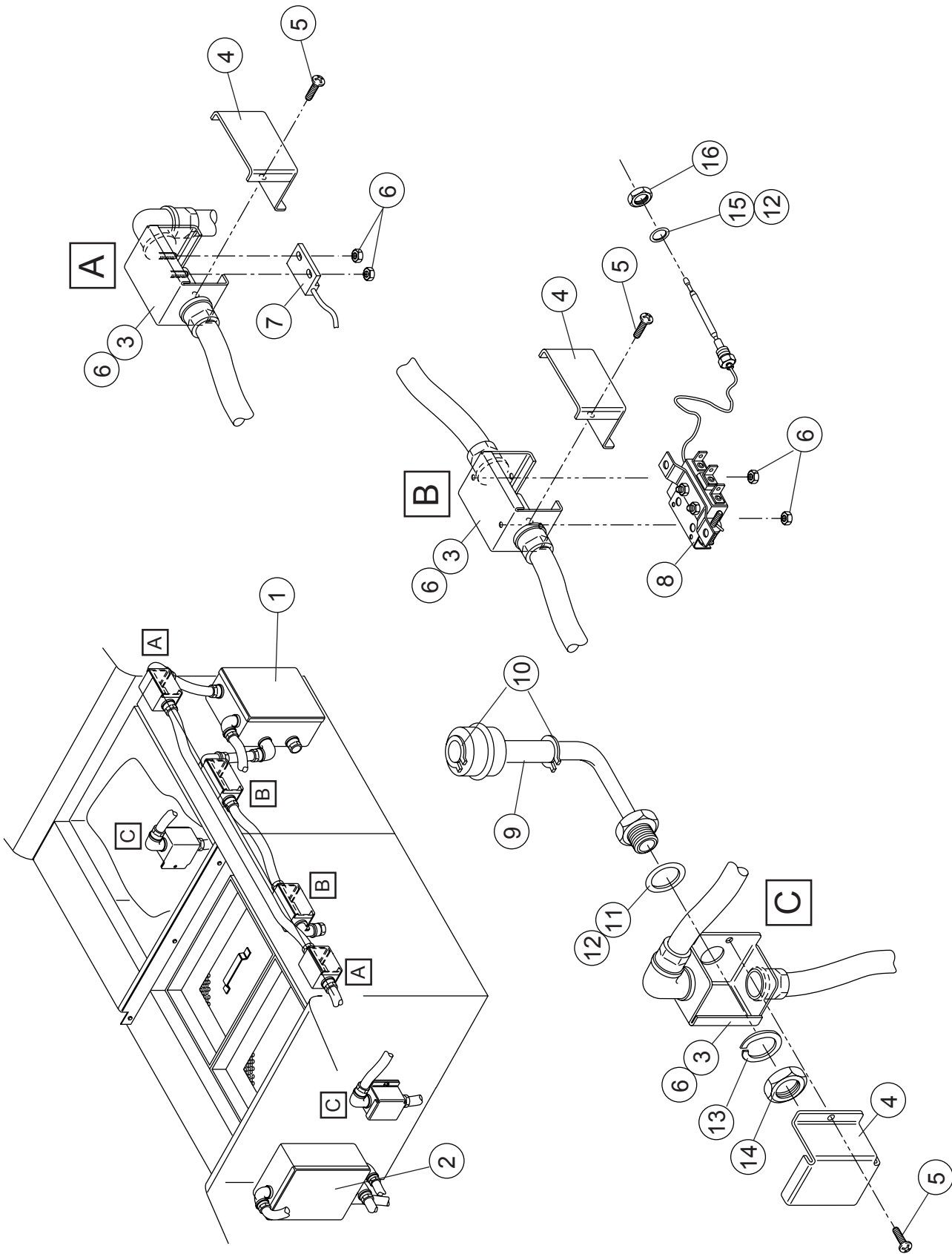

Figure 6.12 -
 Junction boxes, Float switches, Door switches, and Thermostats
 (Prior to S/N J1871)

**JUNCTION BOXES, FLOAT SWITCHES,
DOOR SWITCHES AND THERMOSTATS
(PRIOR TO S/N J1871)**

Fig. 6.12 Item No.	Part No.	Part Description	Qty.
1	100321	Box, electrical, 806 Hoffman	1
2	100309	Box, electrical, 404 Hoffman	1
3	322891	Box, switch	6
4	322892	Cover, switch box	6
5	100007	Screw, 10-32 x 3/8"	6
6	108954	Nut, 6-32	32
7	112659	Switch, magnetic reed	2
8	109069	Thermostat, 110-200°F	2
9	111092	Switch, float	2
10	111151	C-clip, float switch	4
11	100094	Washer, flat, 1/2"	2
12	104889	Putty, sealing compound 440	2
13	107589	Washer, lock, 1/2"	2
14	104584	Nut, plain, 1/2"-13 Hex hd	2
15	201041	Washer, 7/8" ID x 1/8" ThK	2
16	100547	Locknut, 1/2" SST	2

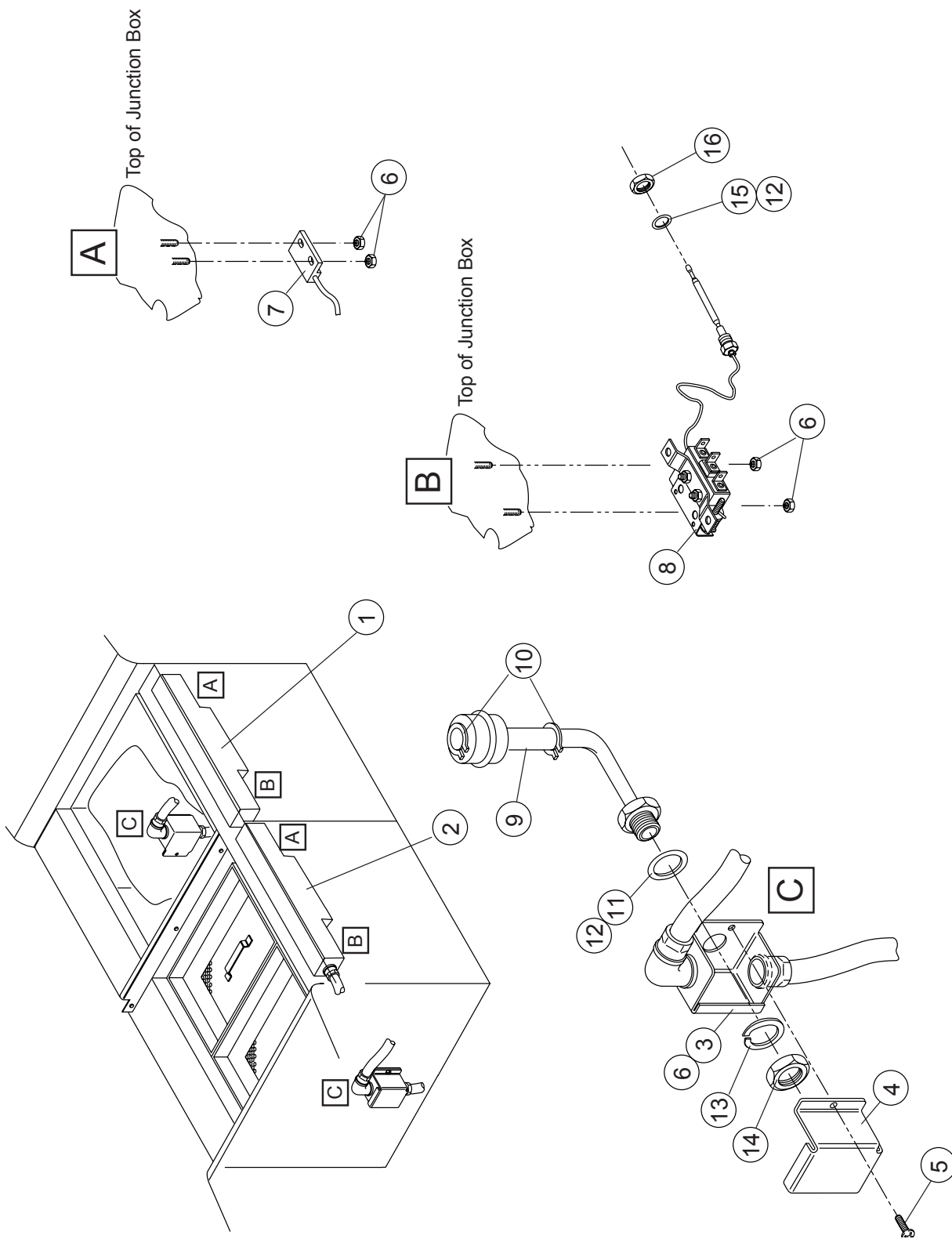

Figure 6.12a-
Junction boxes, Float switches, Door switches, and Thermostats
(For machines beginning with S/N J1872 and above)

**JUNCTION BOXES, FLOAT SWITCHES,
DOOR SWITCHES AND THERMOSTATS
(BEGINNING WITH S/N J1872 AND ABOVE)**

Fig. 6.12a Item No.	Part No.	Part Description	Qty.
1		Box, electrical, 806 HoffmanWash	1
2		Box, electrical, 404 Hoffman Rinse	1
3	322891	Box, switch	6
4	322892	Cover, switch box	6
5	100007	Screw, 10-32 x 3/8"	6
6	108954	Nut, 6-32	32
7	112659	Switch, magnetic reed	2
8	109069	Thermostat, 110-200°F	2
9	111092	Switch, float	2
10	111151	C-clip, float switch	4
11	100094	Washer, flat, 1/2"	2
12	104889	Putty, sealing compound 440	2
13	107589	Washer, lock, 1/2"	2
14	104584	Nut, plain, 1/2"-13 Hex hd	2
15	201041	Washer, 7/8" ID x 1/8" ThK	2
16	100547	Locknut, 1/2" SST	2

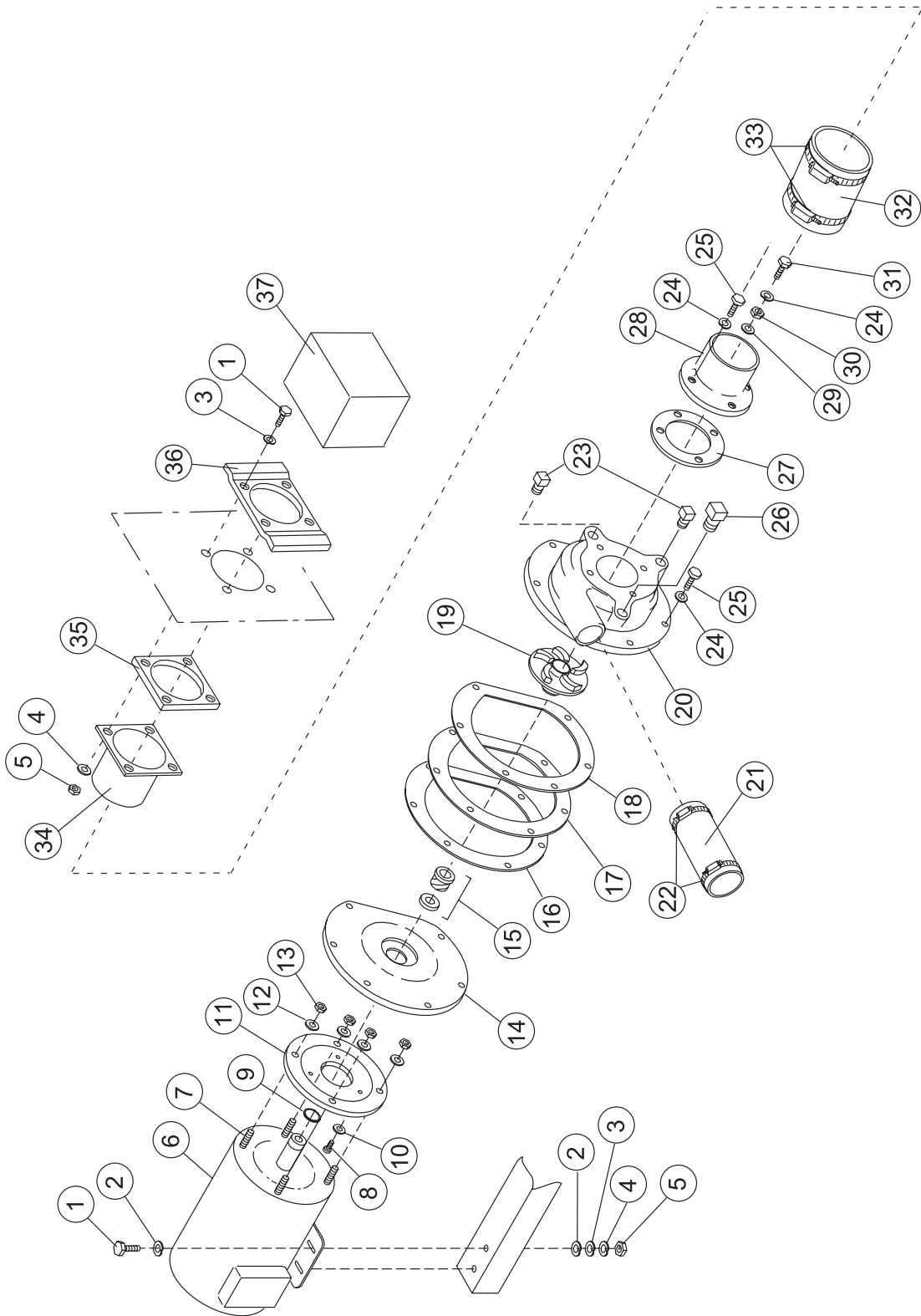

Figure 6.13 -
Pump assembly

PUMP ASSEMBLY

Fig. 6.13 Item No.	Part No.	Part Description	Qty.
1	100740	Bolt, 5/16-18 x 1" Hex hd	12
2	104619	Washer, flat	16
3	102376	Washer, flat, 5/16"	12
4	106013	Washer, lock, 5/16"	12
5	100154	Nut, 5/16-18 Hex hd	12
6	112591	Motor, pump 2HP MV/60/3	1
7	110734	Stud, motor	4
8	100754	Screw, 10-32 x 1/2" flat hd	3
9	109654	Slinger, water	1
10	110270	Washer, star countersunk	3
11	204460	Plate, backing	1
12	106407	Washer, lock	4
13	107690	Nut, jam, 3/8-16	4
14	111681	Flange, pump	1
15	111111	Seal, pump	1
16	111941	Gasket (.0085") (1 notch)	2
17	111942	Gasket (.015") (2 notches)	1
18	111943	Gasket (.032") (3 notches)	2
19	111756	Impeller, 2HP SST	1
20	111696	Volute, pump	1
21	112801	Hose, pump discharge	1
22	111964	Clamp, hose	2
23	102500	Plug, 1/4" NPT, Brass	2
24	106482	Washer, lock, 1/4"	11
25	100736	Bolt, 1/4-20 x 3/4" Hex hd	10
26	102504	Plug, 1/2" NPT, Brass	1
27	112338	Gasket Pump, Suction flange	1
28	112379	Flange, suction machined (Replaces 111841)	1
29	110248	Washer, flat	1
30	110247	Nut, jam, 7/16-20 Hex hd	1
31	100734	Bolt, 1/4-20 x 1/2" Hex hd	1
32	112800	Hose, pump suction	1
33	104203	Clamp, hose	2
34	307995	Flange, suction	1
35	104640	Gasket, pump suction	1
36	319743	Plate, pump suction	1
37	319742	Hood, pump suction	1
—	452331	Pump/Motor assy. Complete LH	1
		(Wash for L-R machine)	
		(Rinse for R-L machine)	
—	452332	Pump/Motor assy. Complete RH	1
		(Wash for R-L machine)	
		(Rinse for L-R machine)	
—	410269	Pump assy. Complete (Includes items 7-20, 23-31)	1
—	900737	Gasket kit (Includes items 16-18)	—
—	900184	Seal/Impeller kit (Includes 15-19)	—

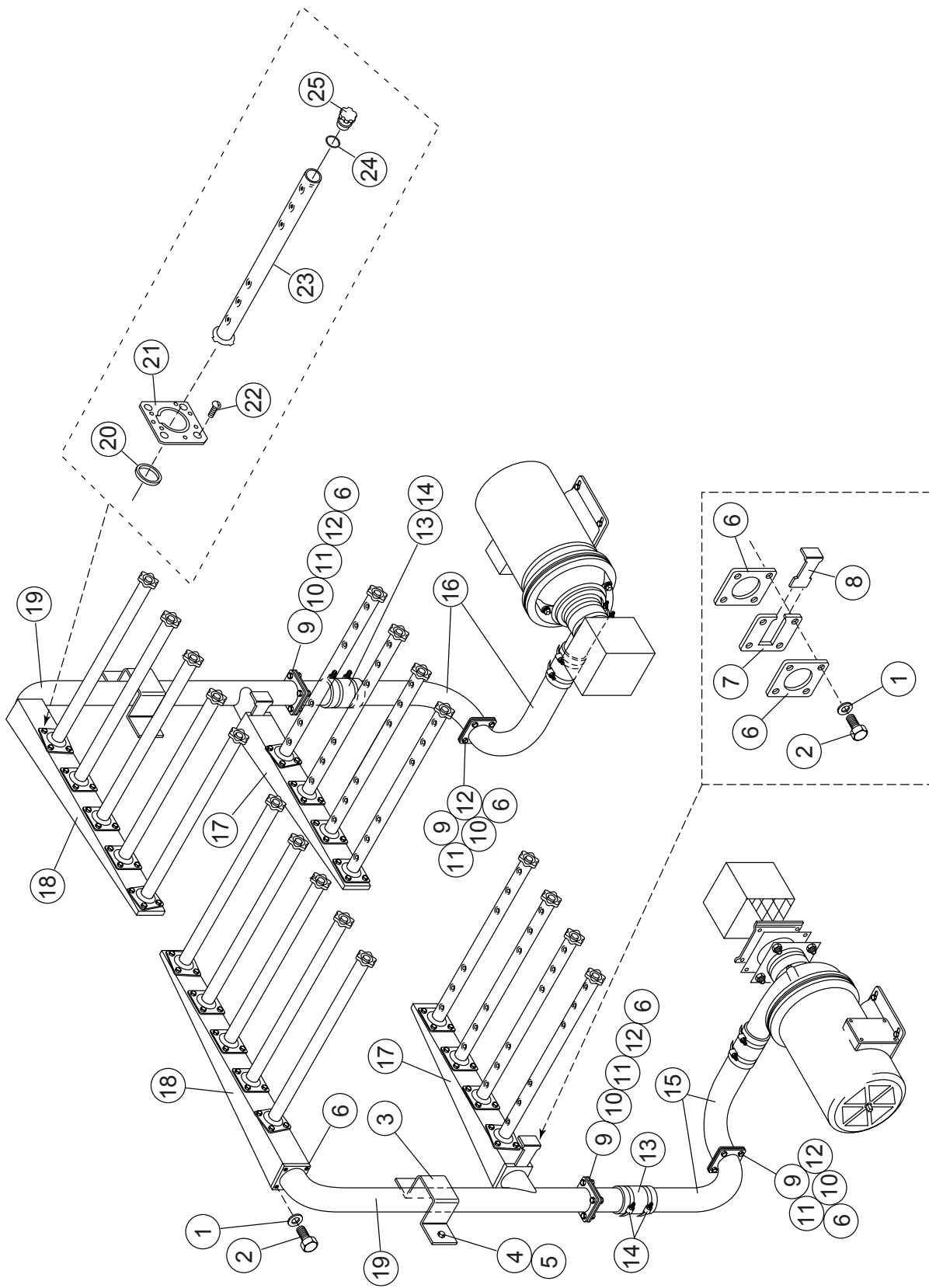

Figure 6.14 -
Wash spray system
(R-L machine shown)

**WASH SPRAY SYSTEM
(R-L MACHINE SHOWN)**

Fig. 6.14 Item No.	Part No.	Part Description	Qty.
1	106482	Washer, lock, 1/4"	16
2	100736	Bolt, 1/4-20 x 3/4" Hex hd	16
3	313212	Bracket, standpipe	2
4	100073	Screw, 1/4-20 x 1/2"	4
5	100141	Nut, grip, 1/4-20	4
6	111456	Gasket, manifold	10
7	316772	Plate, restrictor	2
8	316773	Slide, restrictor	2
9	100739	Bolt, 5/16-18 x 3/4" Hex hd	16
10	102376	Washer, flat, 5/16"	16
11	106013	Washer, lock, 5/16"	16
12	100154	Nut, plain, 5/16-18 Hex hd	16
13	112802	Hose, connecting	2
14	111964	Clamp, hose	4
15	323238	LH side tube	1
16	323239	RH side tube	1
17	317240	Manifold, 4-hole	2
18	410697	Manifold, 5-hole w/restrictor	2
19	322983	Standpipe	2
20	111505	O-ring, spraypipe	18
21	111454	Plate, locking	18
22	111478	Bolt, locking plate, 10-32 x 1/2"	56
23	321471	Spraypipe, debossed	18
24	104414	O-ring, end plug	18
25	112240	Plug, debossed spraypipe	18

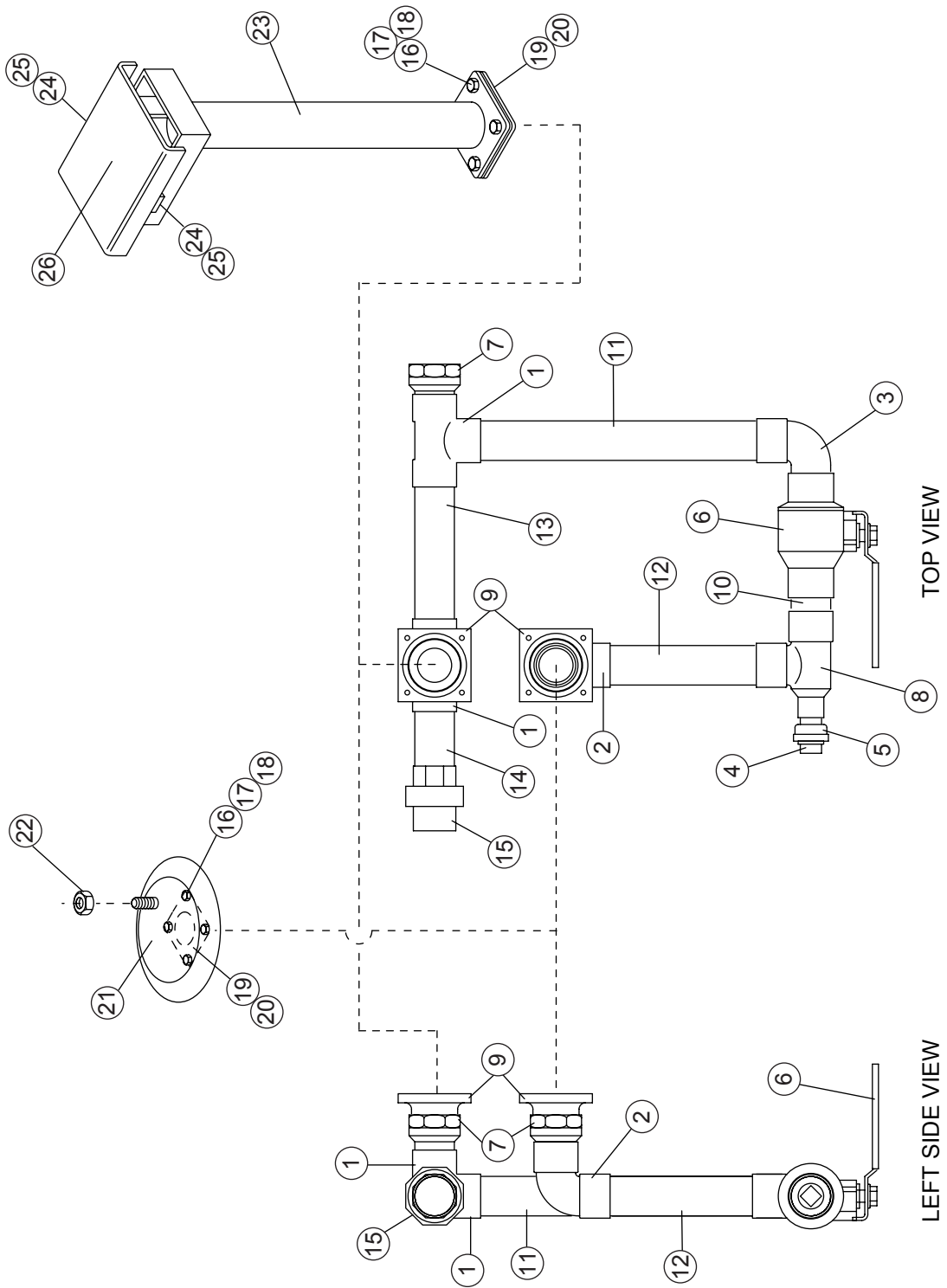

Figure 6.15 -
Drain and overflow assembly

DRAIN AND OVERFLOW ASSEMBLY

Fig. 6.15 Item No.	Part No.	Part Description	Qty.
1	112287	Tee 1-1/2" copper, solder connect	2
2	111353	Elbow, 1-1/2" copper, solder connect	1
3	109110	Elbow 1-1/2" copper x 1-1/2" FTG	1
4	102505	Plug 3/4" brass	1
5	109062	Adapter, 3/4" FTG, x 3/4" FPT copper	1
6	109072	Valve, ball 1-1/2" solder	1
7	113297	Adapter, 1-1/2" x FPT x 1-1/2" FTG copper	3
8	109111	Tee reducer 1-1/2" x 3/4" x 1-1/2" copper	1
9	206139	Flange, drain USN72 mod	2
10	202819	Tube 1-1/2" x 2-3/4" copper	1
11	206137	Tube 1-1/2" x 13-5/8" copper	1
12	206136	Tube 1-1/2" x 8-3/8" copper	1
13	206138	Tube 1-1/2" x 7-1/2" copper	1
14	205598	Tube 1-1/2" x 4-7/16" copper	1
15	109479	Union 1-1/2 copper, solder connect	1
16	100739	Bolt, 5/16-18 x 3/4" Hex hd	16
17	106013	Washer, lock, 5/16"	16
18	102376	Washer, flat, 5/16"	16
19	108345	Gasket	4
20	202191	Flange, drain	4
21	304816	Screen, drain	2
22	107967	Nut, grip, 1/4-20	2
23	323237	Assembly, overflow	2
24	107136	Bolt, 10-32 x 3/8" Hex hd	4
25	104985	Nut, 10-32	4
26	B2857	Cover assy.	2
—	325218	Assembly, drain	2

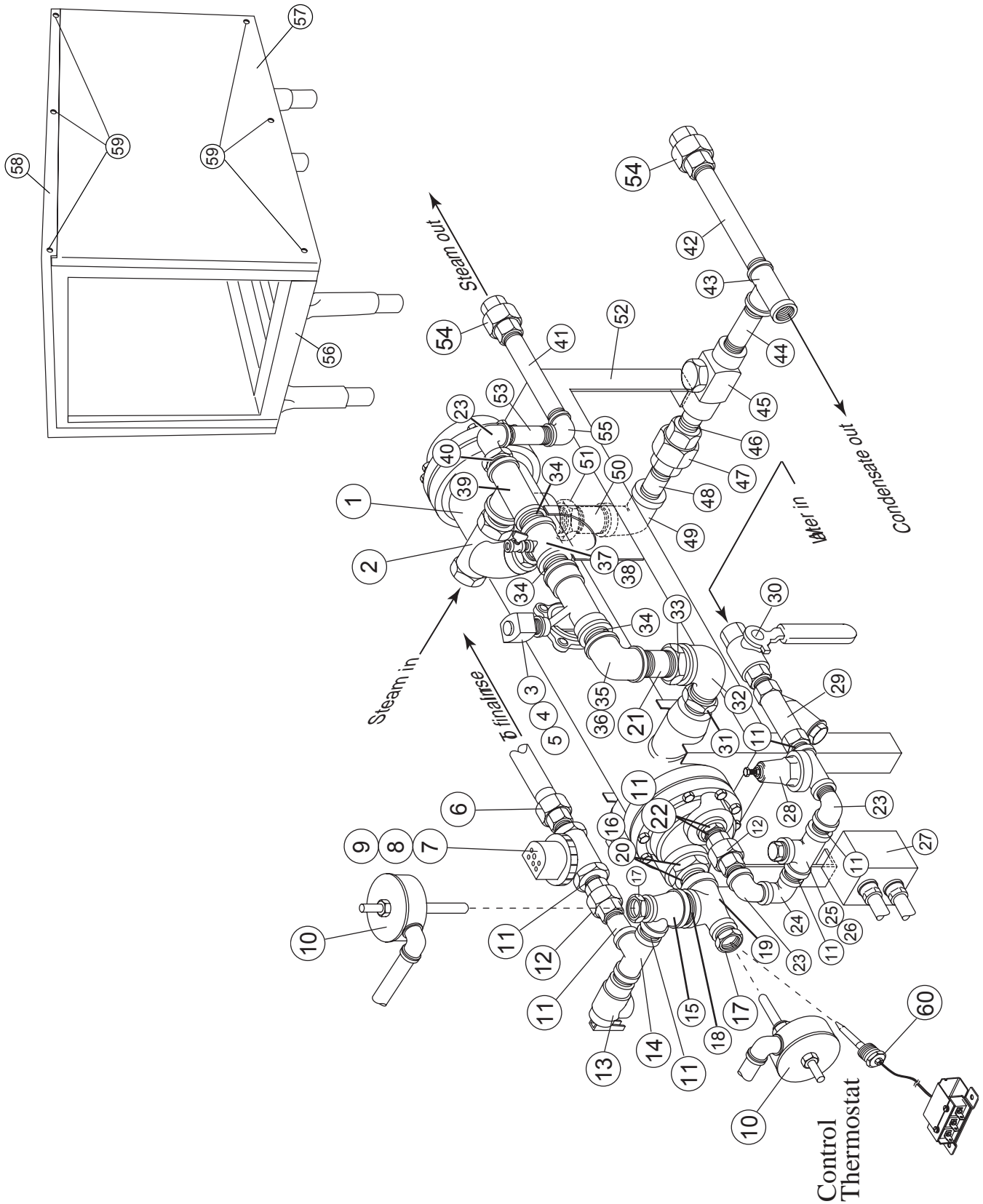

Figure 6.16 -
No. 260 Steam booster and Steam piping assembly
(R-L installation shown)

**NO. 260 STEAM BOOSTER AND STEAM PIPING ASSEMBLY
(R-L INSTALLATION SHOWN)**

Fig. 6.16 Item No.	Part No.	Part Description	Qty.
1	112309	Steam booster, #260 custom	1
2	101249	Line strainer, 1-1/2" brass (105749 plug, 3/4" brass not shown)	1
3	110005	Valve, solenoid, steam 1" NPT Asco	1
4	110007	Repair kit steam valve, 1" NPT Asco	1
5	110120	Coil, solenoid valve, 1" 120v	1
6	Coml	Union, sweat, 3/4" NPT x 3/4" C	1
7	109887	Valve, hot water, 3/4" NPT	1
8	109903	Repair kit, hot water valve, 3/4" NPT	1
9	108516	Coil, solenoid valve, 3/4", 120v	1
10	100128	Thermostat, female	2
11	Coml	Nipple, close, 3/4" NPT, Brass	9
12	Coml	Union, 3/4" NPT, Brass	2
13	104649	Relief valve, 3/4" NPT, 125psi	1
14	Coml	Tee, 3/4" NPT, Brass	1
15	Coml	Tee, reducing, 1-1/4" x 3/4" x 3/4", Brass	1
16	Coml	Nipple, close, 1-1/4" NPT, Brass	1
17	Coml	Bushing, reducing, 3/4" x 1/2" NPT, Brass	2
18	Coml	Nipple, close, 1-1/2", Brass	1
19	Coml	Tee, reducing, 1-1/4" x 3/4" x 1-1/4" NPT, Brass	1
20	Coml	Bushing, reducing, 2" x 1-1/4" NPT, Brass	1
21	Coml	Nipple, 1" NPT x 2-1/2", Brass	1
22	Coml	Bushing, reducing, 2" x 3/4" NPT, Brass	1
23	Coml	Street ell, 3/4" NPT, Brass	2
24	Coml	Elbow, 3/4" NPT, Brass	1
25	Coml	Tee, reducing, 3/4" x 3/4" x 1/2" Brass	1
26	Coml	Plug, 1/2" NPT, Brass	1
27	100309	Junction box	1
28	107550	Pressure regulating valve, 3/4"	1
29	110768	Line strainer, 3/4" NPT, Brass	1
30	104828	Ball valve, 3/4" NPT	1
31	100983	Bushing, reducing, 2" x 1-1/2", brass	1
32	107500	Street elbow, 1-1/2" x 90°, brass	1
33	100979	Bushing, reducing, 1-1/2" x 1", brass	1
34	105847	Nipple, close, 1" NPT, brass	3
35	105733	Elbow, 1" NPT, brass	1
36	105851	Union, 1" NPT, brass (not shown)	1
37	112358	Tee, reducing, 1" x 1" x 1/4", brass	1
38	100123	Petcock, gauge, 1/4" M x F	1
39	110196	Tee, reducing, 1" x 1" x 1-1/2" NPT, brass	1
40	Coml	Bushing reducing, 1" x 3/4" NPT, brass	1
41	Coml	Nipple, 3/4" NPT x 8-3/4" lg., brass	1
42	Coml	Nipple, 3/4" NPT x 7-1/2" lg., brass	1
43	Coml	Tee, reducing, 1" x 3/4" x 3/4" NPT, brass	1
44	Coml	Nipple, 1/2" NPT x 3-1/2" lg., brass	1
45	111380	Steam trap, thermodynamic, 1/2" NPT, SST	1
46	Coml	Nipple, close, 1/2", brass	1
47	Coml	Union, 1/2" NPT, brass	1
48	Coml	Nipple, close, 1/2", brass	1
49	Coml	Elbow, reducing, 3/4" x 1/2" NPT, brass	1
50	105811	Nipple, 3/4" x 3" long, brass	1
51	112341	Bushing, reducing, 2" x 3/4" NPT, brass	1
52	322813	Base weldment, 260 Bstr, Navy	1
53	Coml	Nipple, 3/4" x 4-1/2" lg., brass	1
54	Coml	Union, 3/4", brass	2
55	Coml	Elbow, 3/4" x 90, brass	1
56	325878	Base, stand	1
57	325881	Panel, front	1
58	325880	Panel, top	1
59	100007	Screw (10-32 x 3/8")	6
60	109069	Thermostat w/capillary (after S/N J1698)(Control Thermostat Only)	1

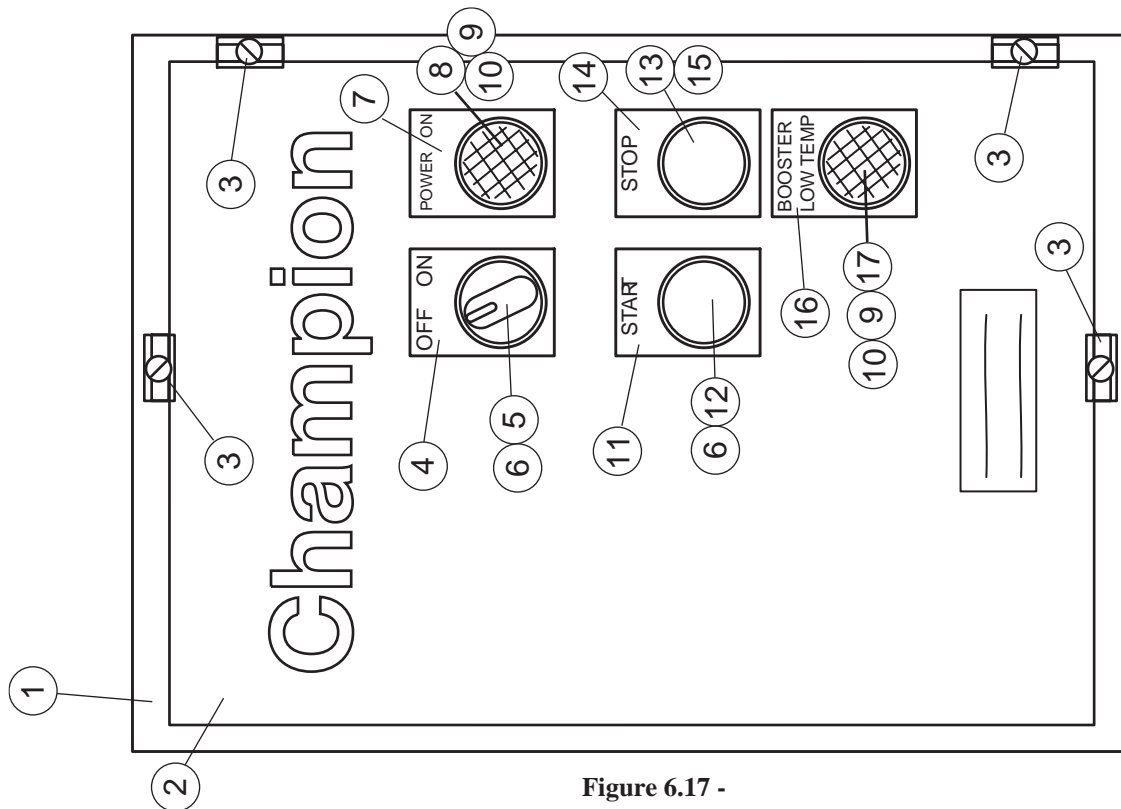
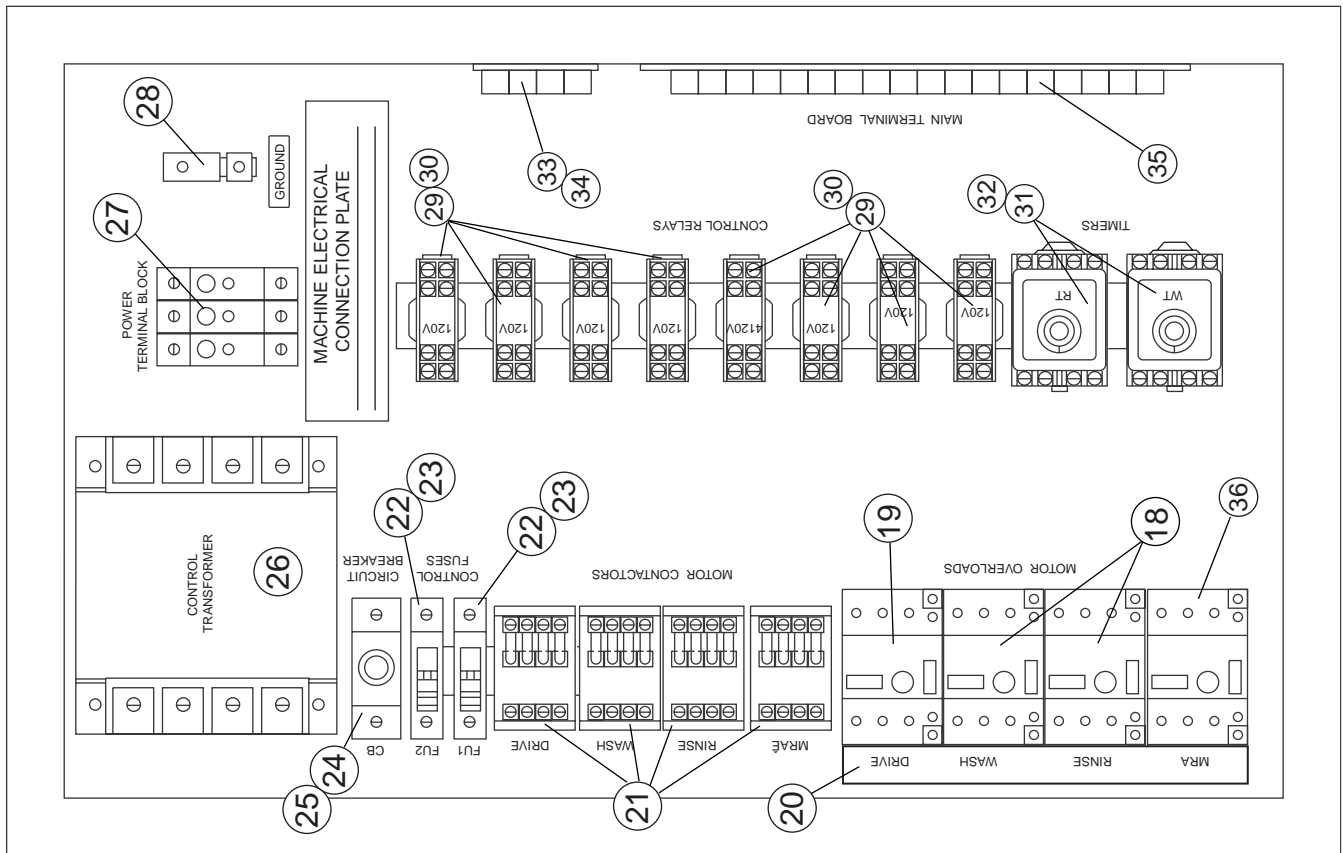

Figure 6.17 -
Steam Remote Control Cabinet
(For Machines Built Prior to J1050)

STEAM REMOTE CONTROL CABINET
(For Machines Built Prior to S/N J1050)

Fig. 6.17 Item No.	Part No.	Part Description	Qty.
1	322969	Cabinet, SST	1
2	322814	Lid, cabinet.....	1
3	107860	Clip, hold down assy.	4
*4	111802	Nameplate, Off-On (No Longer Available).....	1
*5	111691	Switch, selector, 2 position (No Longer Available)	1
(*) *6	111617	Block, contact, No	2
7	112694	Nameplate, Power On	1
8	112041	Lens, green pilot lite 64	1
9	111685	Block, lighted contact.....	2
10	111686	Bulb, 120v	2
**11	112822	Nameplate, Start (Replaces 107618)	1
~*12	111614	Pushbutton, green	1
***13	111616	Block, contact NC	2
**14	112823	Nameplate, Stop (Replaces 107617)	1
***15	111615	Pushbutton, red	1
16	112693	Nameplate, booster low temp	1
17	110980	Lens, red pilot lite 64	1
18	111627	Overload, mtr. (2.4-4.0A) wash / rinse	2
19	111624	Overload, mtr. (0.6-1.0A) drive	1
20	111671	Bus bar, 3-units (w/o MRAN 90)	1
—	110812	Bus bar, 4-units (with MRAN 90)	1
21	108122	Contractor, mtr. 12A.....	4
22	111153	Block, fuse 600v	2
23	111821	Fuse, 3A (ATDR-3)	2
24	106995	Circuit breaker, 5A	1
25	304326	Bracket, circuit breaker	1
26	107091	Transformer, 500va	1
27	111833	Block, terminal 185A, 3 pole 600v	1
28	103310	Lug, ground wire	1
29	111036	Socket, relay	8
30	111068	Relay, 2PDT 10A 120vac	8
31	112352	Socket, timer	2
32	112351	Timer, Omron H2C-8R	2
33	107171	Block, terminal (chemical dispensing).....	1
34	112296	Label, chemical dispensing signal.....	1
35	108607	Block, terminal 18 pt.....	1
36	111625	Overload, mtr., (1.0-1.6A) MRAN 90°	1
*	900848	Kit*On Off Switch (Includes 113670 Switch, 112821 Nameplate, 111617 Contact Block N.O) (Includes items 4-6)	1
**	900847	Kit*Start Switch Assy (Includes 111614 Pushbutton Green, 111617 Contact block N.O., 112822 Nameplate)(Includes items 6,11, 12) ...	1
***	900846	Kit*Stop Switch Assy (Includes 111615 Pushbutton Red, 111616 Contact Block N.C., 112823 Nameplate)(Includes items 13-15)	1

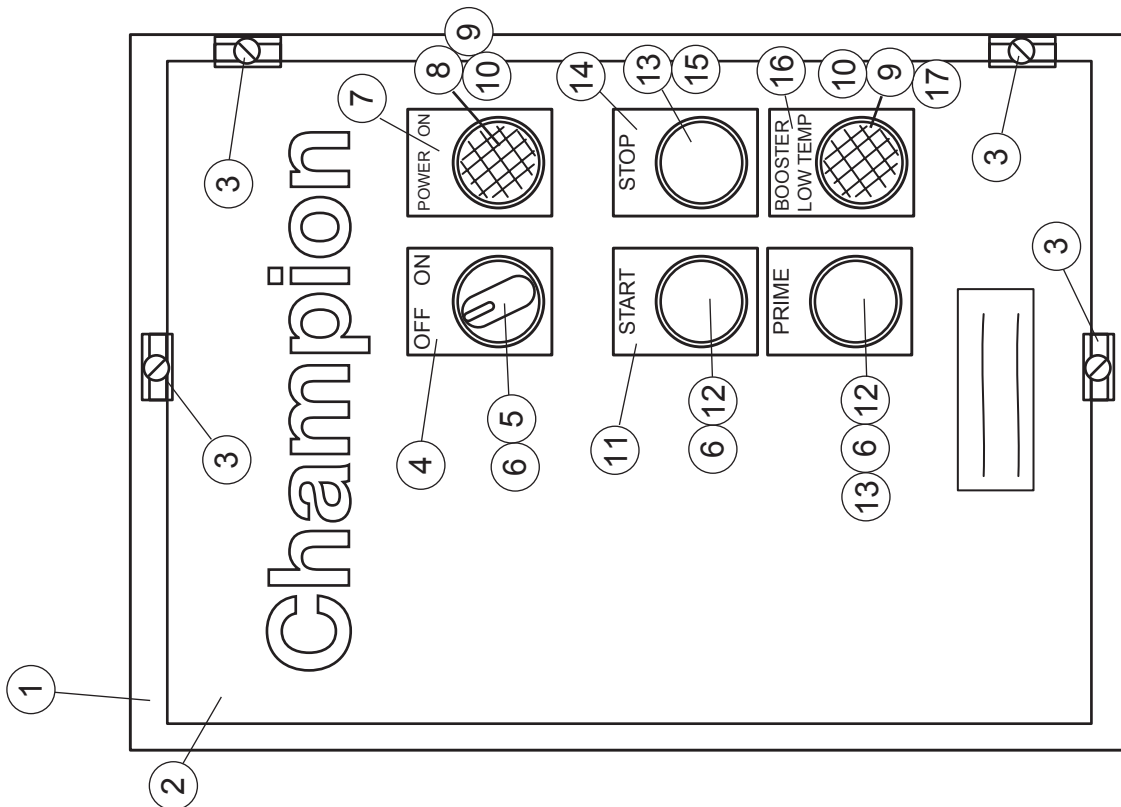
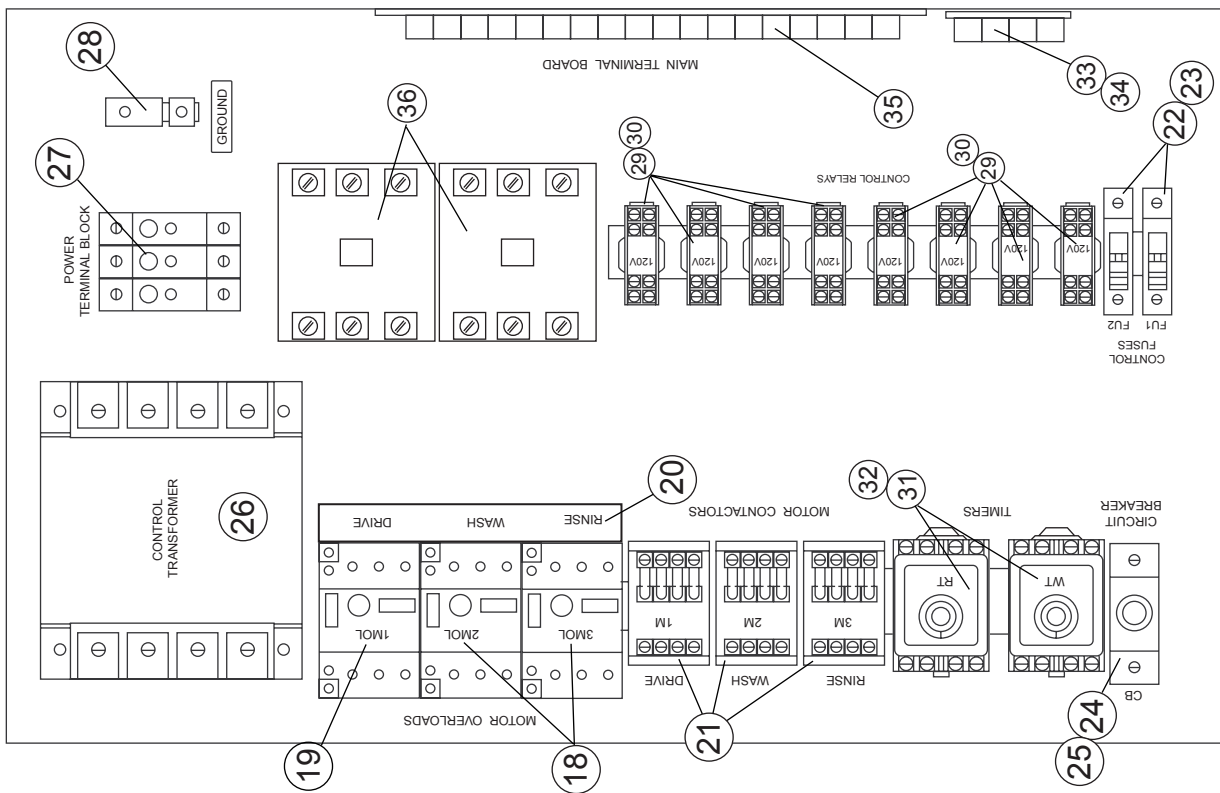

Figure 6.17a-
Electric Remote Control Cabinet
(For machines beginning with S/N J1050 and above)

ELECTRIC REMOTE CONTROL CABINET*(For Machines Beginning with S/N J1050 and up to J1080)*

Fig. 6.17a Item No.	Part No.	Part Description	Qty.
1	322969	Cabinet, SST	1
2	322814	Lid, cabinet	1
3	107860	Clip, hold down assy.	4
*4	111802	Nameplate, Off-On	1
*5	111691	Switch, selector, 2 position	1
(**) *6	111617	Block, contact, NO	3
7	112694	Nameplate, Power On	1
8	112041	Lens, green pilot lite	1
9	111685	Block, lighted contact	2
10	111686	Bulb, 120V	2
** 11	112822	Nameplate, Start (Replaces 107618)	1
** 12	111614	Pushbutton, green	2
*** 13	111616	Block, contact NC	3
*** 14	112833	Nameplate, Stop (Replaces 107617)	1
*** 15	111615	Pushbutton, red	1
16	112693	Nameplate, booster low temp	1
17	110980	Lens, red pilot lite	1
18	111627	Overload, mtr. (2.4-4.0A) wash/rinse	2
19	111624	Overload, mtr. (0.6-1.0A) drive	1
20	111671	Bus bar, 3-unit (w/o MRAN 90)	1
—	110812	Bus bar, 4-unit (With MRAN 90)	1
21	108122	Contactor, mtr. 12A	3
22	111153	Block, fuse 600v	2
23	111821	Fuse, 3A (ATDR-3)	2
24	106995	Breaker, circuit 5A	1
25	304326	Bracket, circuit breaker	1
26	107091	Transformer, 500va	1
27	111833	Block, terminal 185A, 3 pole 600V	1
28	103310	Lug, ground wire	1
29	111036	Socket, relay	8
30	111068	Relay, 2PDT 10A 120VAC	8
31	112352	Socket, timer	2
32	112351	Timer, omron H2C-8R	2
33	107171	Block, terminal (chemical dispensing)	1
34	112296	Label, chemical dispensing signal	1
35	108607	Block, terminal 18pt.	1
36	111827	Contactor, block 3 pole 60A	2
37	111625	Overload, mtr. (1.0-1.6A) MRAN 90°	1
*	900848	Kit* On Off Switch (Includes 112821 Nameplate, 113670 Switch, 111617 Contact Block N.O.) (Includes items 4-6)	1
**	900847	Kit*Start Switch Assy (Includes 111614 Pushbutton Green, 111617 Contact Block N.O., 112822 Nameplate)(Includes items 6,11,12)...	1
***	900846	Kit*Stop Switch Assy (Includes 111615 Pushbutton Red, 111616 Contact Block N.C.,112823 Nameplate)(Includes items 13-15)	1

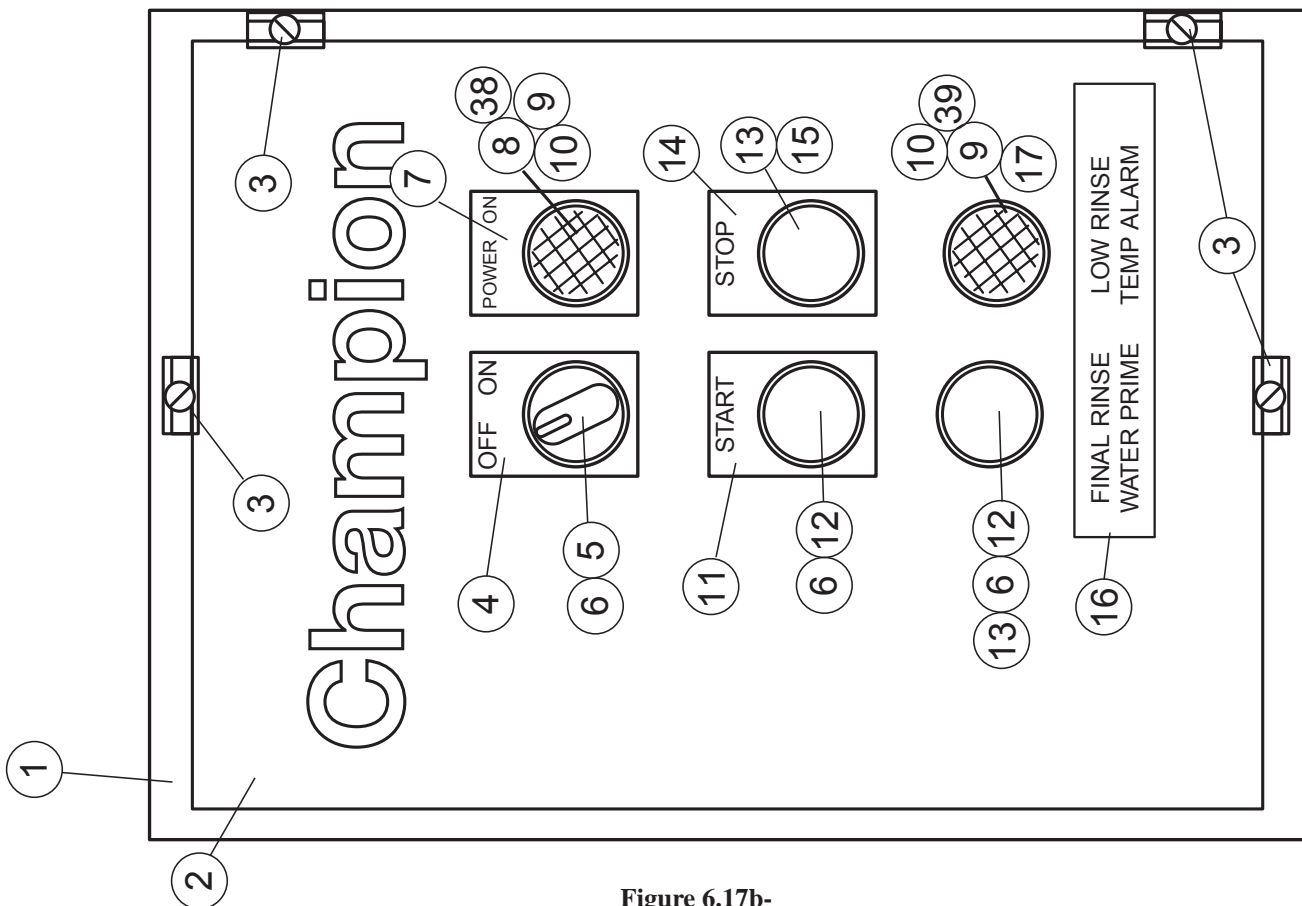
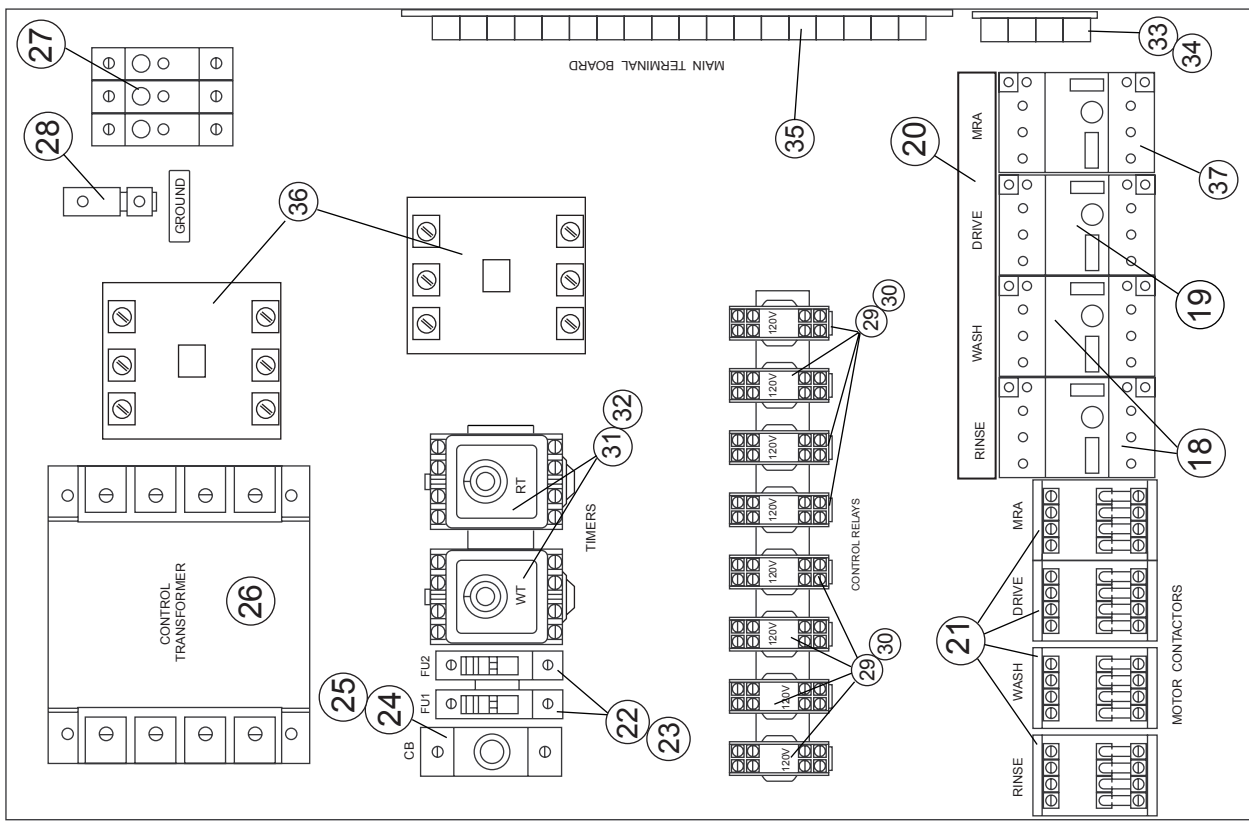
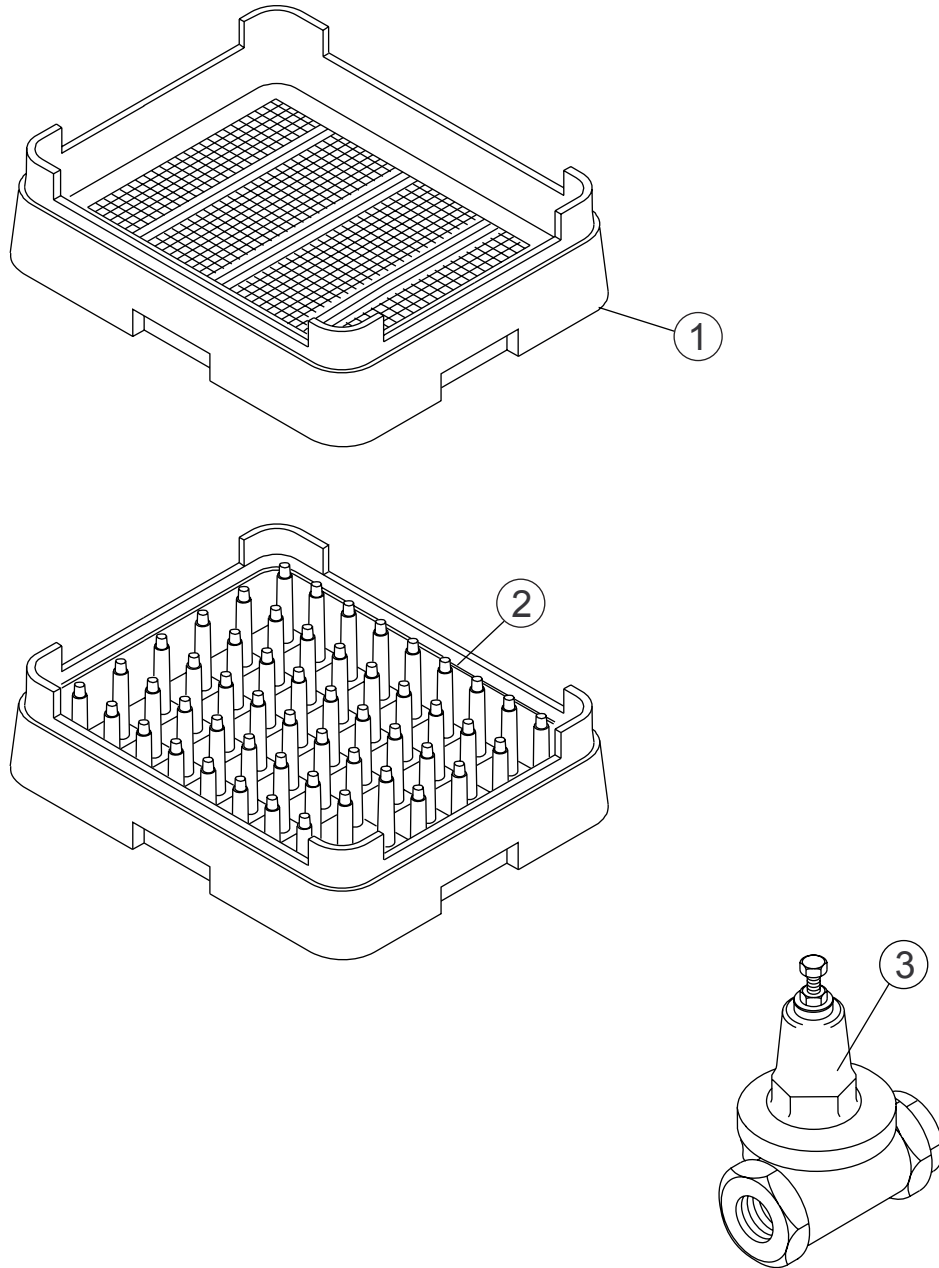

Figure 6.17b-
Steam or Electric Remote Control Cabinet
(For Machines Beginning with S/N J1080 and Above)

STEAM OR ELECTRIC REMOTE CONTROL CABINET*(For Machines Beginning with S/N J1080 and Above)*

Fig. 6.17b Item No.	Part No.	Part Description	Qty.
1	322969	Cabinet, SST	1
2	322814	Lid, cabinet	1
3	107860	Clip, hold down assy.	4
4	111802	Nameplate, Off-On	1
5	113670	Switch, selector, 2 position(Replaces 112814)(See Kits Below)	1
6	111617	Block, contact, NO (Replaces 112819) (See Kits Below)	3
7	112824	Nameplate, Power On 22MM (See Kits Below)	1
8	113751	Lens, green pilot lite (Replaces 112815) (See Kit Below)	1
9	112817	Lampholder 120V 22MM (See Kits Below)	2
10	112818	Bulb, 120V 22MM (See Kits Below)	2
11	112822	Nameplate, Start (See Kits Below)	1
12	111614	Pushbutton, green (Replaces 112812) (See Kits Below)	2
13	111615	Block, contact NC (Replaces 112820) (See Kits Below)	3
14	112823	Nameplate, Stop (See Kits Below)	1
15	111615	Pushbutton, red (Replaces 112811) (See Kits Below)	1
16	113195	Nameplate, Low temp alarm/prime (See Kits Below)	1
17	113753	Lens, red pilot lite (Replaces 112816) (See Kits Below)	1
18	111627	Overload, mtr. (2.4-4.0A) wash/rinse	2
19	111624	Overload, mtr. (0.6-1.0A) drive	1
20	111671	Bus bar, 3-unit (w/o MRAN 90)	1
—	110812	Bus bar, 4-unit (With MRAN 90)	1
21	108122	Contact, mtr. 12A	3
22	111153	Block, fuse 600v	2
23	111821	Fuse, 3A (ATDR-3)	2
24	106995	Breaker, circuit 5A	1
25	304326	Bracket, circuit breaker	1
26	107091	Transformer, 500va	1
27	111833	Block, terminal 185A, 3 pole 600V	1
28	103310	Lug, ground wire	1
29	111036	Socket, relay	8
30	111068	Relay, 2PDT 10A 120VAC	8
31	112352	Socket, timer	2
32	112351	Timer, omron H2C-8R	2
33	107171	Block, terminal (chemical dispensing)	1
34	112296	Label, chemical dispensing signal	1
35	108607	Block, terminal 18pt.	1
36	111827	Contact, block 3 pole 60A (Electric Heat Only)	2
37	111625	Overload, mtr. (1.0-1.6A) MRAN 90°	1
38	113752	Mounting base LED green	1
39	113754	Mounting base LED red	1
---	900848	Kit*On Off Switch Assy (Includes items 4-6)	A/R
---	900849	Kit*Light Assy Green (Includes items 7-10, 38)	A/R
---	900847	Kit*Start Switch Assy (Includes items 6, 11, 12)	A/R
---	900846	Kit*Stop Switch Assy (Includes items 13-15)	A/R
---	900851	Kit*Rinse Prime Button (Includes items 6, 12, 13)	A/R
---	900850	Kit*light Assy Red (Includes items 9, 10, 16, 17, 39)	A/R



**Figure 6.18-
Dishracks and PRV**

DISHRACKS AND PRV

Fig. 6.18 Item No.	Part No.	Part Description	Qty.
1	101273	Rack, flat bottom	1
2	101285	Rack, peg	1
3	107550	Valve, pressure reducing (PRV)	1

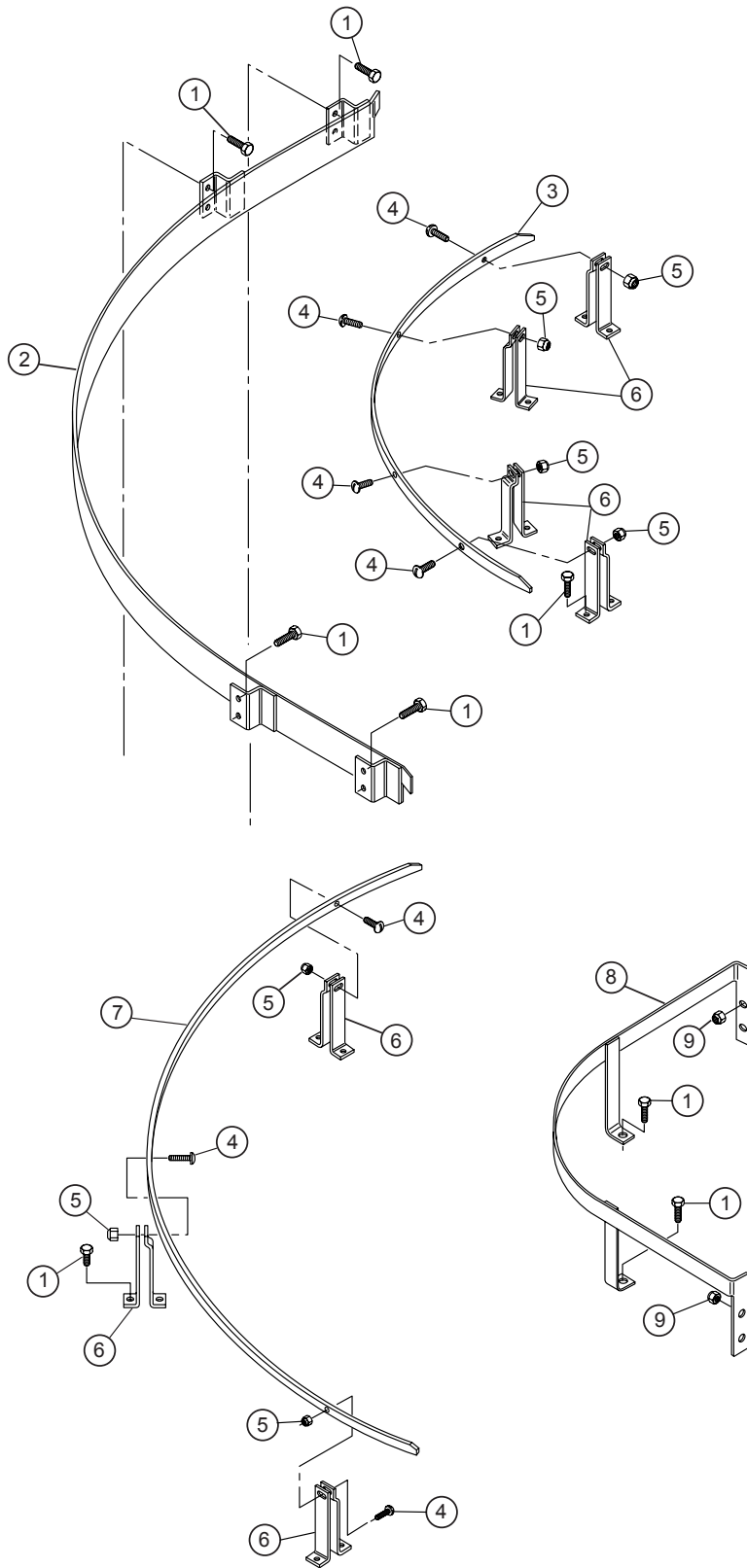

Figure 6.19-
MRAN 90° Guides

MRAN 90° GUIDES

Fig. 6.19 Item No.	Part No.	Part Description	Qty.
1	100735	Bolt (1/4" x 5/8") Hex hd	A/R
2	310180	Guide, rack advance	1
3	314640	Rack, support inner	1
4	111370	Screw (10-32 x 5/8") Hex hd	7
5	107966	Nut, grip (10-32)	7
6	314466	Rack, support	7
7	314641	Rack, support outer	1
8	314649	Rack, support inner	1
9	107967	Nut, grip (1/4-20 w/nylon insert)	A/R

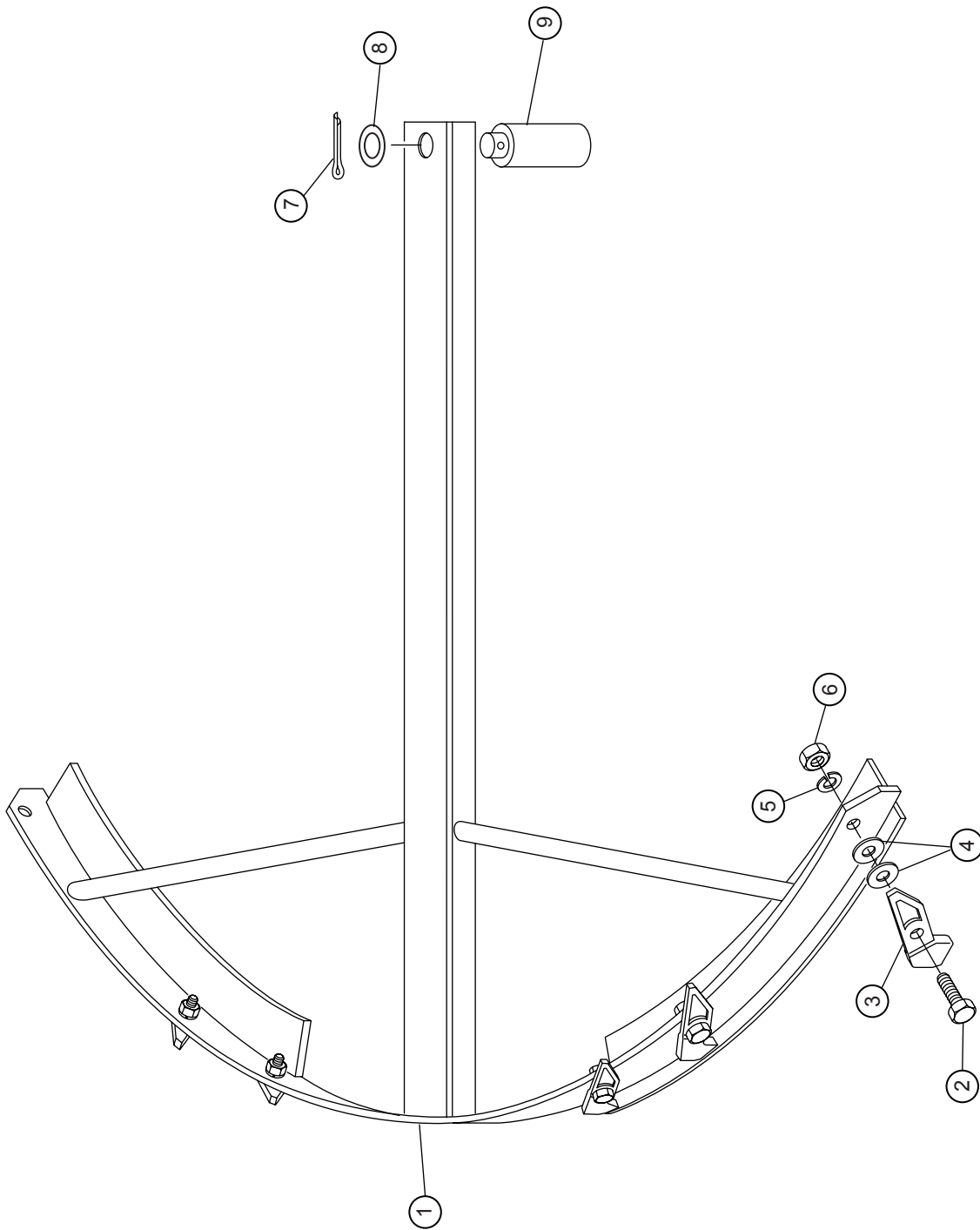

Figure 6.20-
MRAN 90° Pawl Bar

MRAN 90° PAWL BAR

Fig. 6.20 Item No.	Part No.	Part Description	Qty.
1	314605	Bar, pawl	1
2	110240	Bolt, pawl mounting	7
3	110236	Pawl, rack advance	7
4	102376	Washer (5/16" x 3/4" x 1/16")	7
5	106013	Washer, lock (5/16" split)	7
6	110553	Nut, 8mm SST	7
7	106560	Pin, cotter (1/8" x 1/-1/2")	1
8	320156	Washer (1-1/4" x 3/4" x 1/16")	1
9	111062	Shaft, pivot	1

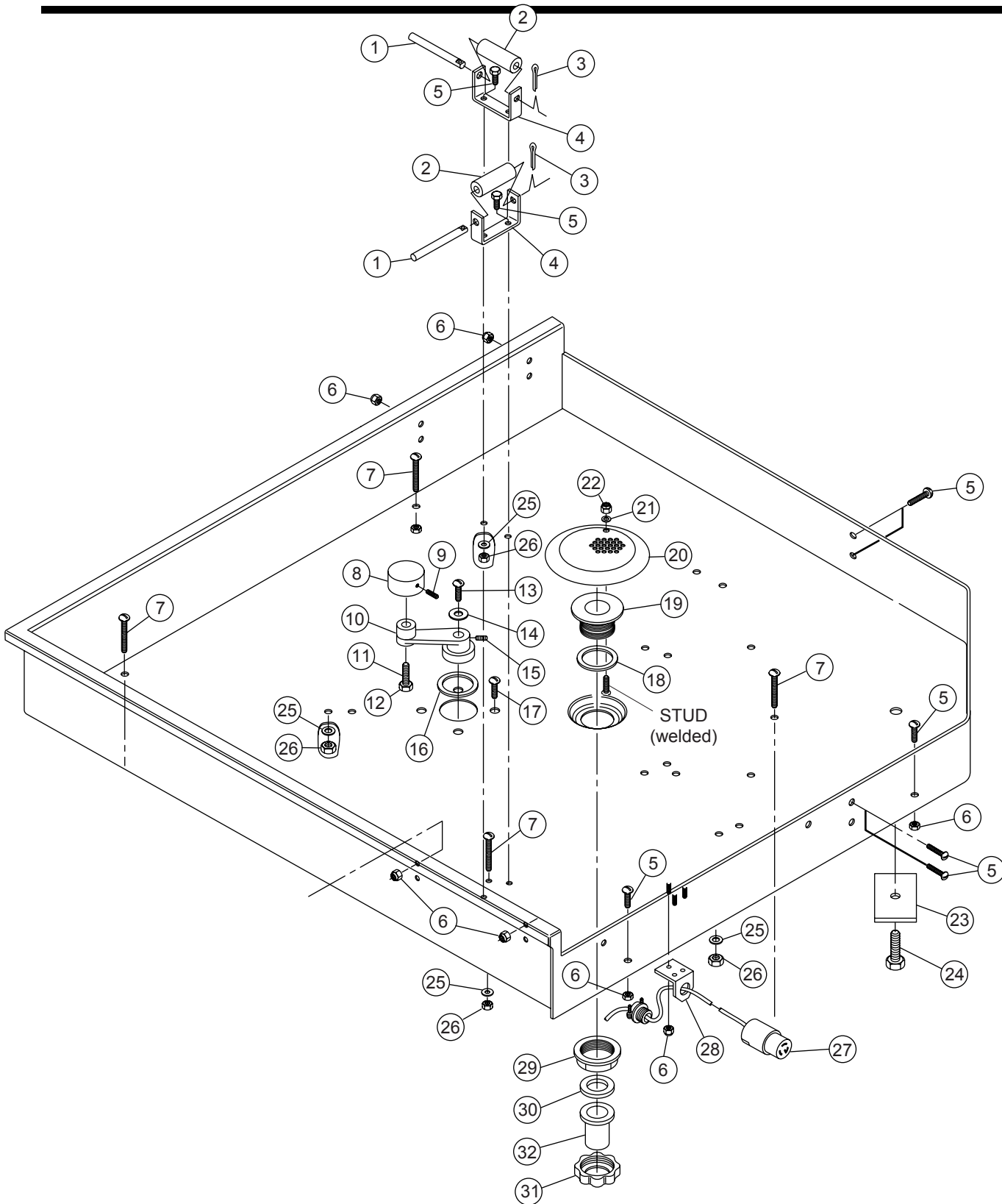

Figure 6.21-
MRAN 90° Table and Drain Assembly

MRAN 90° TABLE AND DRAIN ASSEMBLY

Fig. 6.21 Item No.	Part No.	Part Description	Qty.
1	202392	Pin, roller	2
2	106138	Roller, pawl bar	2
3	106558	Pin, cotter (1/8" x 3/4")	2
4	314352	Bracket, roller	2
5	100735	Bolt (1/4-20 x 5/8")	A/R
6	107967	Nut, grip (1/4-20 w/nylon insert)	A/R
7	107966	Nut, grip (10-32)	4
8	202381	Roller, crosshead	1
9	100769	Screw, set (3/8-16 x 3/4" dog point).....	1
10	202386	Crank	1
11	100868	Stud, roller	1
12	107089	Nut, jam 1/2-13	1
13	100007	Screw (10-32 x 3/8) Truss hd.	1
14	104925	Washer (1/4" x 1")	1
15	100771	Screw, set (1/4-20 x 1/4) Socket hd	1
16	103180	Ring, wiper	1
17	100153	Bolt (3/8-16 x 1") Hex hd.	4
18	107864	Washer, packing	1
19	107863	Outlet, waste	1
20	304816	Strainer, 6"	1
21	106482	Washer, lock 1/4" split.....	1
22	10003	Nut, plain 1/4-20 SST	1
23	314354	Stiffener, shaft	1
24	100747	Bolt (1/2-13 x 1")	1
25	106026	Washer (1/4" x 5/8" x 1/16") SST	A/R
26	100141	Nut, grip (1/4-20) SST	A/R
27	112145	Receptacle (Optional for roller table only)	1
28	320261	Bracket, cord (Optional for roller table only)	1
29	107865	Locknut	1
30	107866	Washer, packing	1
31	107867	Nut, outlet pipe	1
32	109283	Tailpiece, straight	1

* Please note that the direction of the crank arm should be clockwise when looking down from the top of the table.

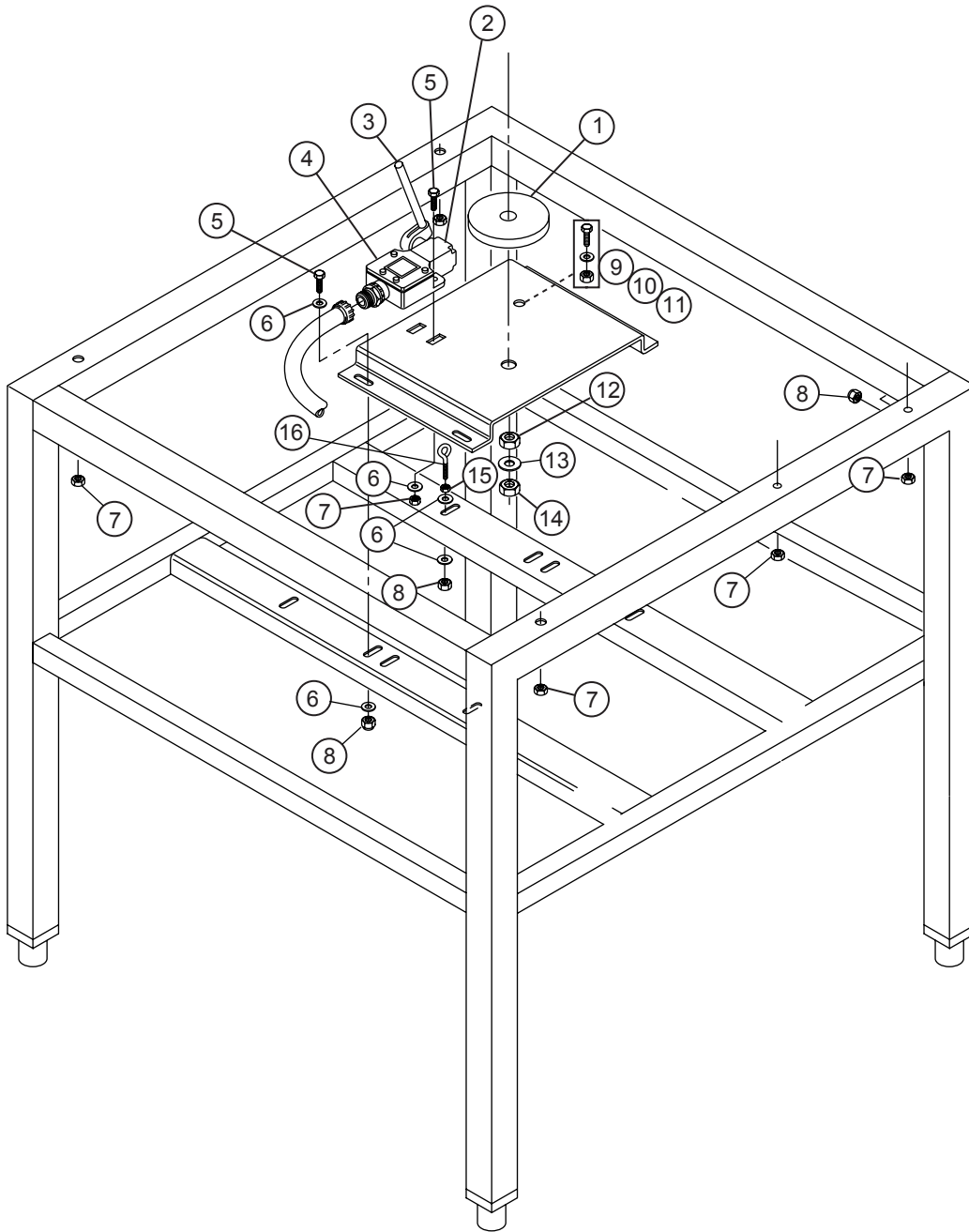

Figure 6.22-
MRAN 90° Base Assembly

MRAN 90° BASE ASSEMBLY

Fig. 6.22 Item No.	Part No.	Part Description	Qty.
1	111063	Plate, spacer	1
2	111075	Roller head, limit switch	1
3	111074	Lever rod, limit switch	1
4	107341	Switch, limit	1
5	100735	Bolt (1/4-20 x 5/8") Hex hd.	1
6	106026	Washer (1/4" x 5/8" x 1/16") SST	A/R
7	107967	Nut, grip (1/4-20) w/nylon insert	A/R
8	100141	Nut, grip (1/4-20) SST	A/R
9	111114	Bolt (3/8 -16 x 3-1/2") SST	1
10	106407	Washer, lock (3/8" split)	1
11	100141	Nut plain	1
12	104584	Nut, plain (1/2-13) Hex hd.	1
13	107589	Washer, lock (1/2 external)	1
14	107089	Nut, jam (1/2-13)	1
15	100003	Nut, plain (1/4-20) SST	1
16	111095	Bolt, eye (1/4-20 x 1")	1

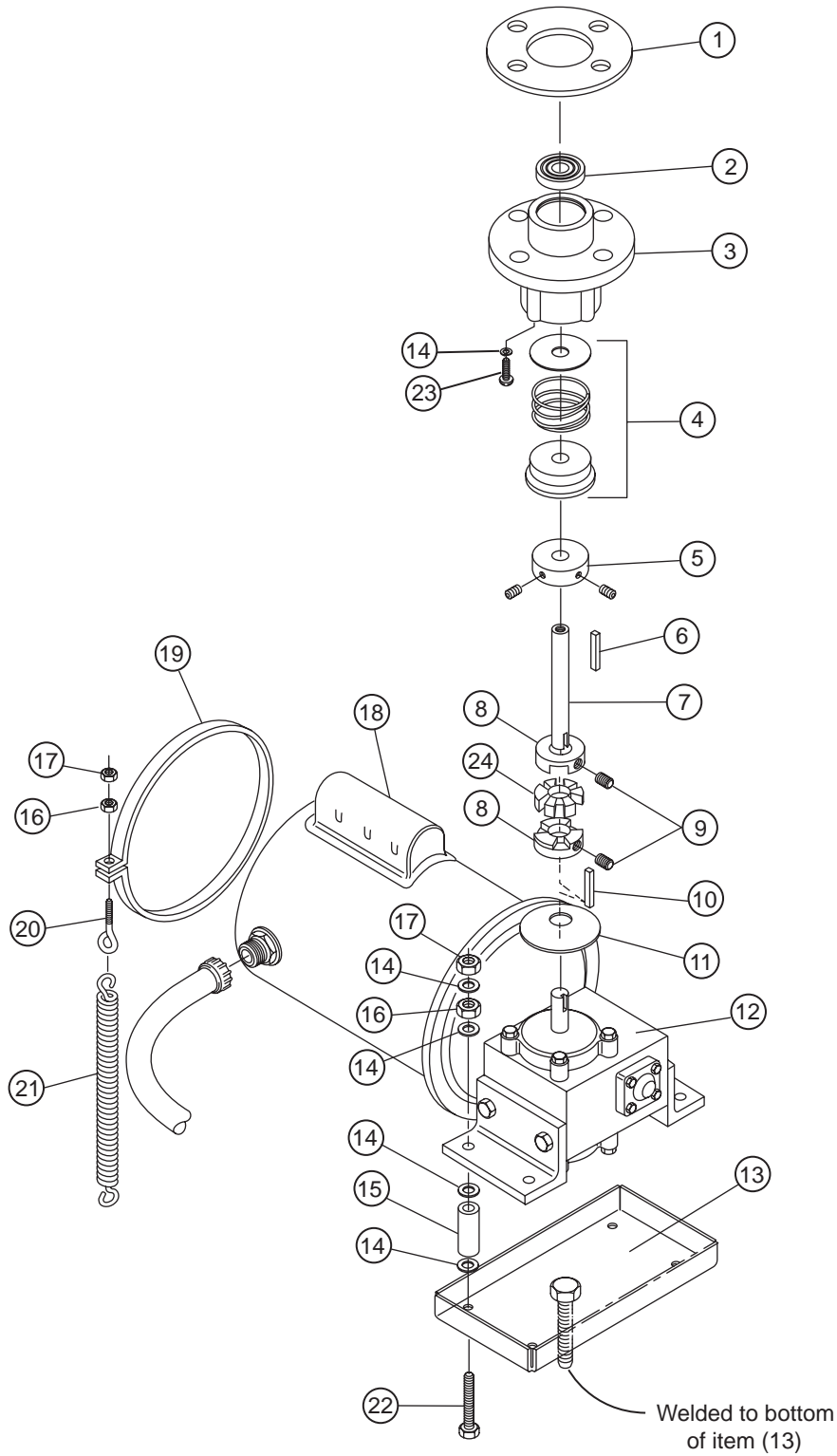

Figure 6.23-
MRAN 90° Drive and Motor Assembly

MRAN 90° DRIVE AND MOTOR ASSEMBLY

Fig. 6.23 Item No.	Part No.	Part Description	Qty.
1	108820	Gasket, bearing housing	1
2	102384	Bearing (comes with item 3)	1
3	B1074-1	Housing, bearing	1
4	102244	Seal assy	1
5	100382	Bearing (comes with set screws)	1
6	106619	Key (3/16" x 3/16" x 1")	1
7	111066	Shaft, rack advance	1
8	111603	Coupler, Shaft	2
9	100771	Screw, set (1/4-20 x 1/4") socket hd.	1
10	104916	Key (3/16" x 3/16" x 3/4")	1
11	100870	Slinger, water	1
12	110152	Reducer	1
13	314364	Base, reducer	1
14	106026	Washer	8
15	105296	Spacer, SST	4
16	100003	Nut, plain (1/4-20) SST	6
17	100141	Nut, grip (1/4-20) SST	6
18	112877	Motor (1/2 HP 115/208-240V/1HP)	1
19	325622	Clamp, motor	1
20	111095	Bolt, eye (1/4-20 x 1")	1
21	111076	Spring, motor return	1
22	106028	Bolt (1/4-20 x 2-1/2") Hex Hd.	4
23	104923	Screw (1/4-20 x 3/8") Round Hd.	4
24	111605	Coupling, spider	1

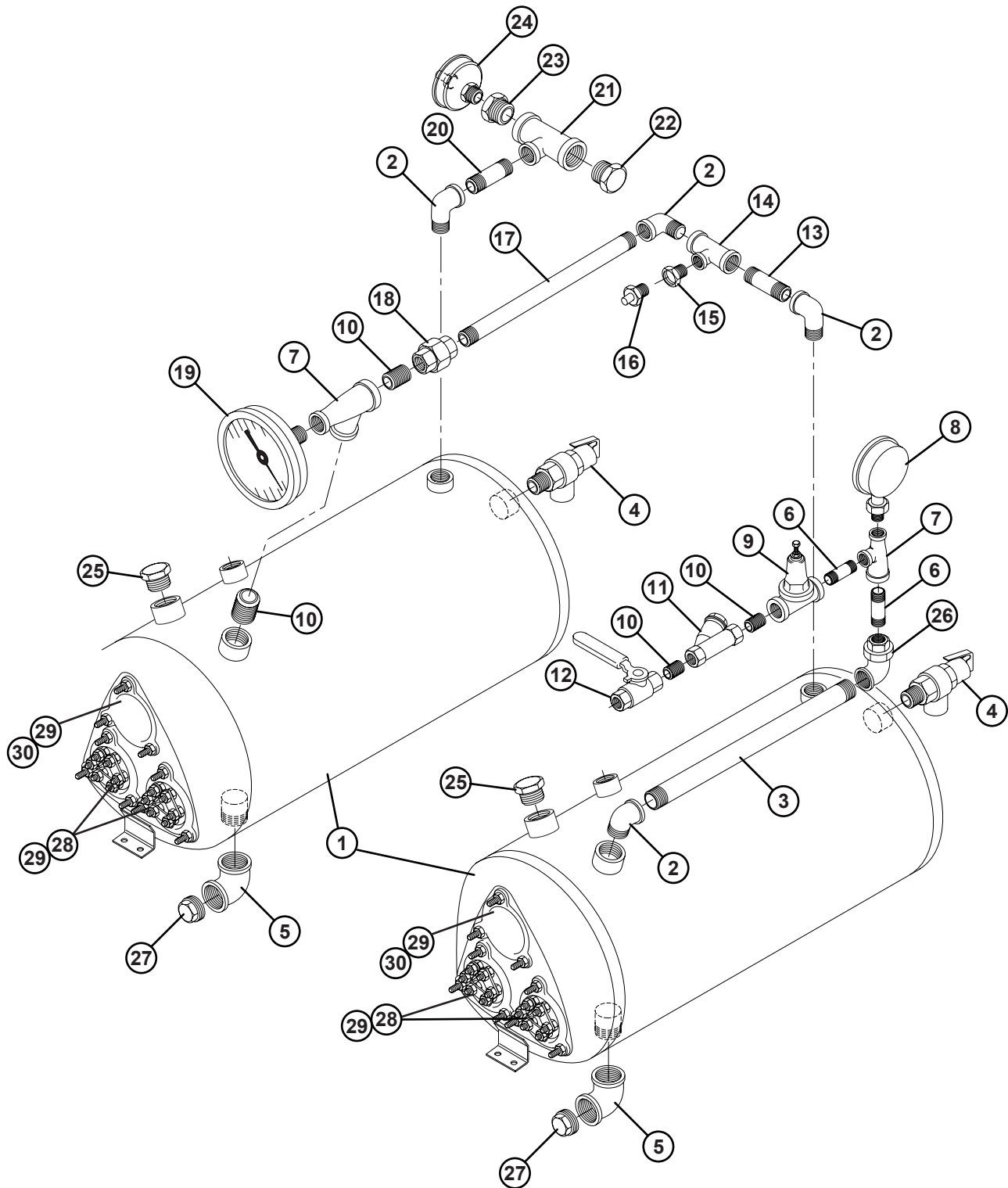

Figure 6.24-
CH-60 Electric Booster Piping
(For USS Ramage Only)

CH-60 ELECTRIC BOOSTER PIPING

Fig. 6.24 Item No.	Part No.	Part Description	Qty.
1	325508	Cannister, booster	2
2	102444	Elbow, street 3/4" x 90° brass	4
3	101582	Nipple, 3/4" x 18-1/2" brass	1
4	113201	Valve, 3/4" relief	2
5	102443	Elbow, 3/4" x 90° SST	2
6	102651	Nipple, 3/4" x 2" brass	2
7	102525	Tee, reducer 3/4" x 1/2" x 3/4" brass	2
8	107828	Gauge, Pressure temperature	2
9	107550	Valve, pressure reducing 3/4"	1
10	100184	Nipple, 3/4" close brass	4
11	110768	Strainer, line 3/4" brass	1
12	104828	Valve, ball 3/4" brass	1
13	102489	Nipple, 3/4" x 2-1/2" brass	1
14	102526	Tee, reducer 3/4" x 3/4" x 1/2"	2
15	102390	Bushing, reducer 1/2" x 3/8" brass	1
16	113170	Probe, water level	1
17	102676	Nipple, 3/4" x 10-1/2" brass	1
18	100571	Union, 3/4 NPT brass	1
19	104682	Thermometer 1/2" NPT stem	1
20	102653	Nipple 3/4" x 4" brass	1
21	102535	Tee, reducer 1" x 1" x 3/4" brass	1
22	102396	Bushing, reducer 1" x 3/4" brass	1
23	102394	Bushing, reducer 1" x 1/2" brass	1
24	100128	Thermostat	1
25	102392	Bushing, reducer 3/4" x 1/2" brass	1
26	106911	Union, elbow 3/4" x 90° Female brass	1
27	102506	Plug 3/4" NPT SST	2
*28	112595	Heater, 15KW 440V/60 /3	4
29	109985	O-ring	6
*30	109458	Plate, blockoff	2
* Mounting hardware:			
—	100003	Nut, plain (1/4-20) SST	3
—	106482	Washer, lock (1/4" split)	3

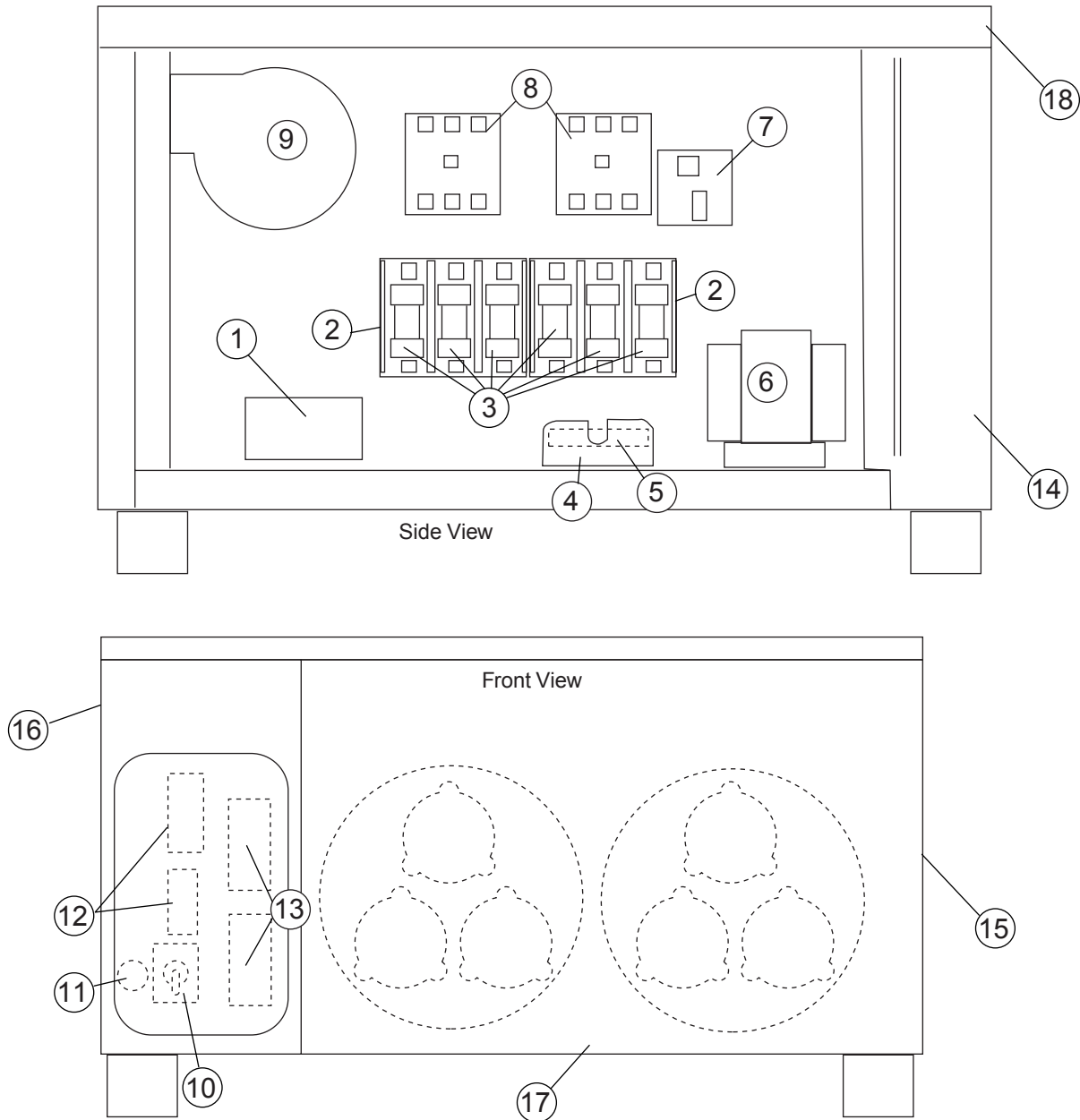
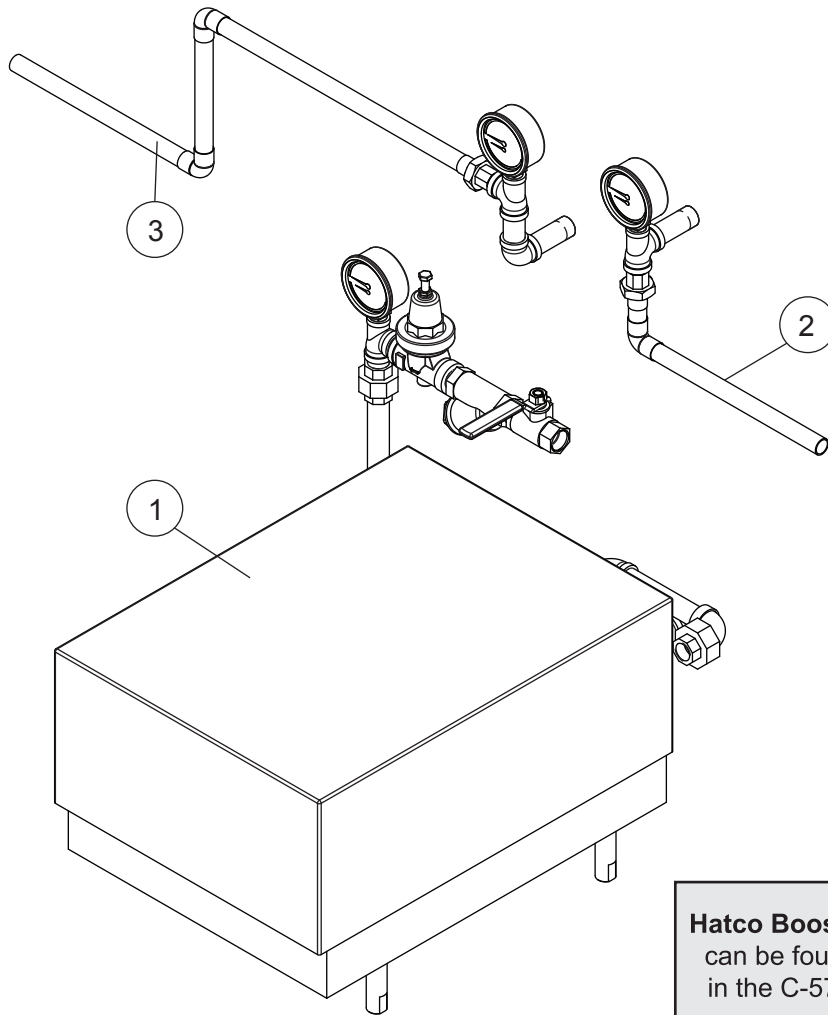

Figure 6.25-
CH-60 Electric Booster Control Cabinet
(For USS Damage Only)

CH-60 ELECTRIC BOOSTER CONTROL CABINET

Fig. 6.25 Item No.	Part No.	Part Description	Qty.
1	111833	Block, terminal 185A 3 pole	1
2	180171	Block., fuse 600V, 60A	2
3	180175	Fuse, type J 50A	6
4	112424	Block, fuse	1
5	112887	Fuse, ATDR 1/2A Time delay	2
6	109064	Transformer	1
7	113186	Board, water level control	1
8	111827	Contactora, 60FLA	2
9	112083	Fan, blower	1
10	107351	Switch, toggle DPDT	1
11	106364	Light, pilot green 120V	1
12	109069	Thermostat, control	2
13	110561	Thermostat, high limit	2
14	325511	Panel, corner post	1
15	325512	Panel, RH side	1
16	325513	Panel LH side	1
17	325514	Panel Front	1
18	325523	Panel Top	1



Hatco Booster Replacement Parts List
 can be found at the end of this manual
 in the C-57 Conversion Kit Instructions.

Item No.	Part No.	Description	Qty.
1	453403	Hatco C57 - MODIFIED BOOSTER	1
2	601902	PIPING - C57 STANDARD LR OUTLET	1
3	601903	PIPING - C57 STANDARD RL OUTLET	1

Figure 6.26-
C57 Electric Booster
(For Machines Beginning with S/N J08122570 and Above)

PART 7:

**ELECTRICAL
SCHEMATICS**

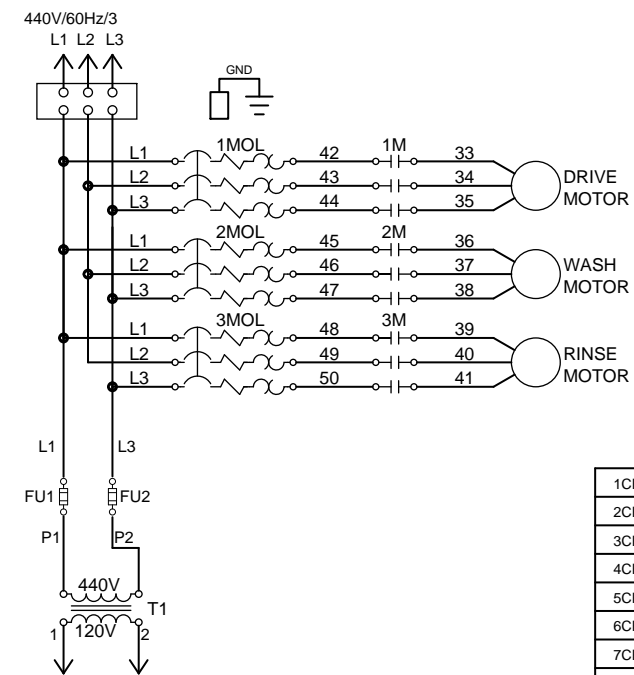
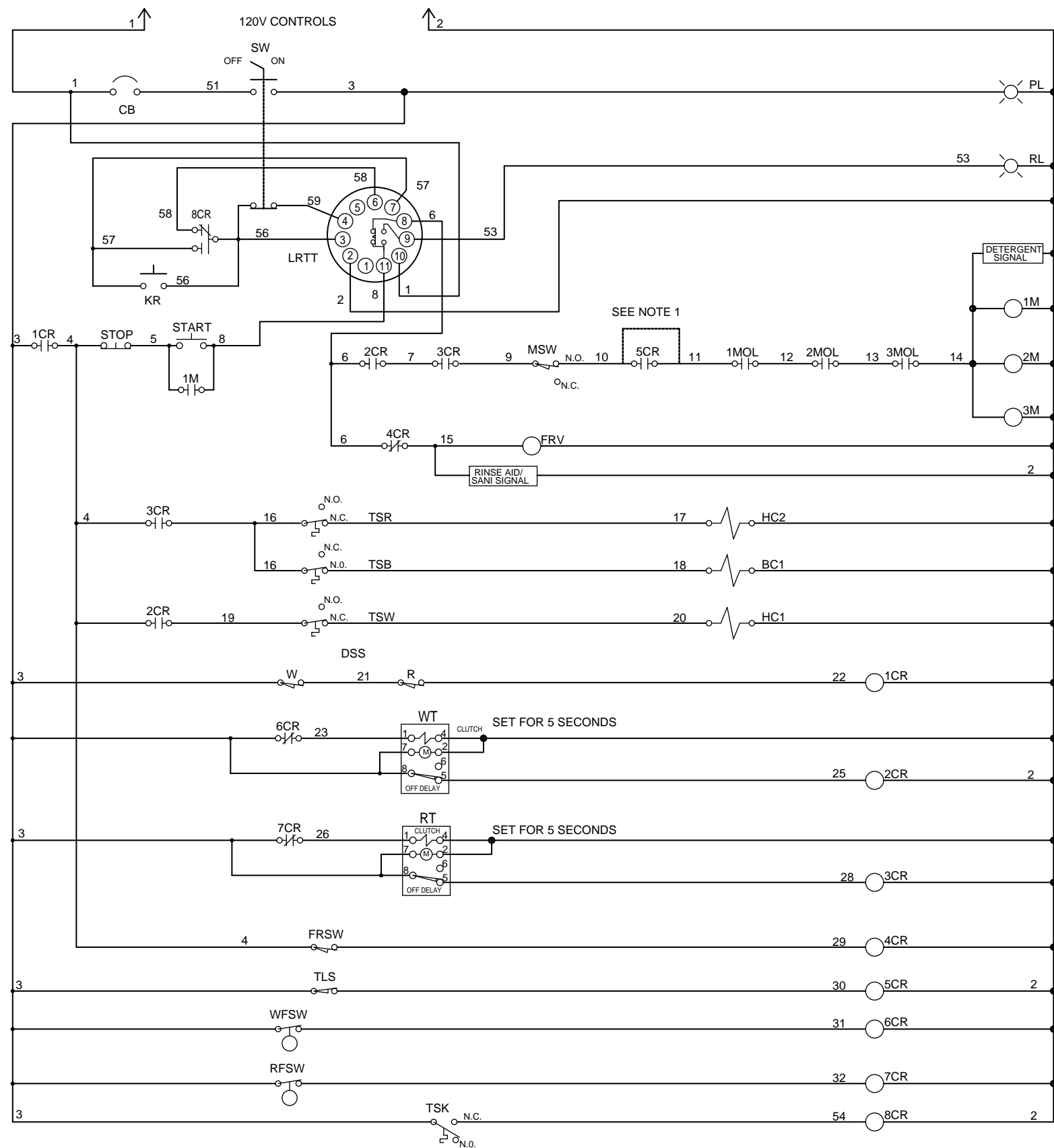

1CR	DOOR SAFETY SWITCH HOLD-IN RELAY
2CR	WASH TANK FLOAT HOLD-IN RELAY
3CR	RINSE TANK FLOAT HOLD-IN RELAY
4CR	FINAL RINSE SWITCH RELAY
5CR	TABLE LIMIT SWITCH RELAY
6CR	WASH TANK FLOAT SWITCH RELAY
7CR	RINSE TANK FLOAT SWITCH RELAY
8CR	LOW TEMP RELAY
1M	DRIVE CONTACTOR
1MOL	DRIVE MOTOR OVERLOAD
2M	WASH CONTACTOR
2MOL	WASH MOTOR OVERLOAD
3M	RINSE CONTACTOR
3MOL	RINSE MOTOR OVERLOAD
BC1	BOOSTER STEAM SOLENOID VALVE
CB	CIRCUIT BREAKER
DSS	DOOR SAFETY SWITCH
FRSW	FINAL RINSE SWITCH
FRV	FINAL RINSE FILL VALVE
FU-	FUSE-TRANSFORMER
HC1	WASH TANK STEAM SOLENOID VALVE
HC2	RINSE TANK STEAM SOLENOID VALVE
KR	KEYED RESET SWITCH
LRTT	LOW RINSE TEMPERATURE TIMER
MSW	MOTOR STOP SWITCH
PL	POWER ON LIGHT
RFSW	RINSE TANK FLOAT SWITCH
R	RINSE TANK DOOR SAFETY SWITCH
RL	RESET LIGHT
RT	RINSE TANK FLOAT TIMER
SW	POWER SWITCH
T1	440V-120V TRANSFORMER
TKL	LOW TEMP INDICATOR LIGHT
TLS	TABLE LIMIT SWITCH
TSK	BOOSTER THERMOSTAT
TSR	RINSE TANK THERMOSTAT
TSW	WASH TANK THERMOSTAT
W	WASH TANK DOOR SAFETY SWITCH
WFSW	WASH TANK FLOAT SWITCH
WT	WASH TANK FLOAT TIMER

NOTES
 1. REMOVE JUMPER ACROSS N.O. 5CR CONTACT WHEN TABLE LIMIT SWITCH IS USED.

DIAGRAM STATE
 POWER OFF
 DOORS CLOSED
 TANKS EMPTY
 END OF CYCLE

CUSTOMER TO SUPPLY RATED VOLTAGE/PHASE/HZ, AS SPECIFIED PER ORDER, TO DISCONNECT SWITCH. ALL POWER SUPPLIED TO EACH CONNECTION POINT MUST COMPLY WITH ALL LOCAL ELECTRIC CODES.			
DR.BY	J.NEWTON	SCALE	
DATE	30OCT97	SHEET	1 OF 1

REV.	DESCRIPTION	DATE	BY
D	ADDED LOW RINSE TEMPERATURE TIMER	21APRIL98	JCN

REV.	DESCRIPTION	DATE	BY

Champion
 The Dishwashing Machine Specialists

USN-72 STEAM		
B	701541	REV. D

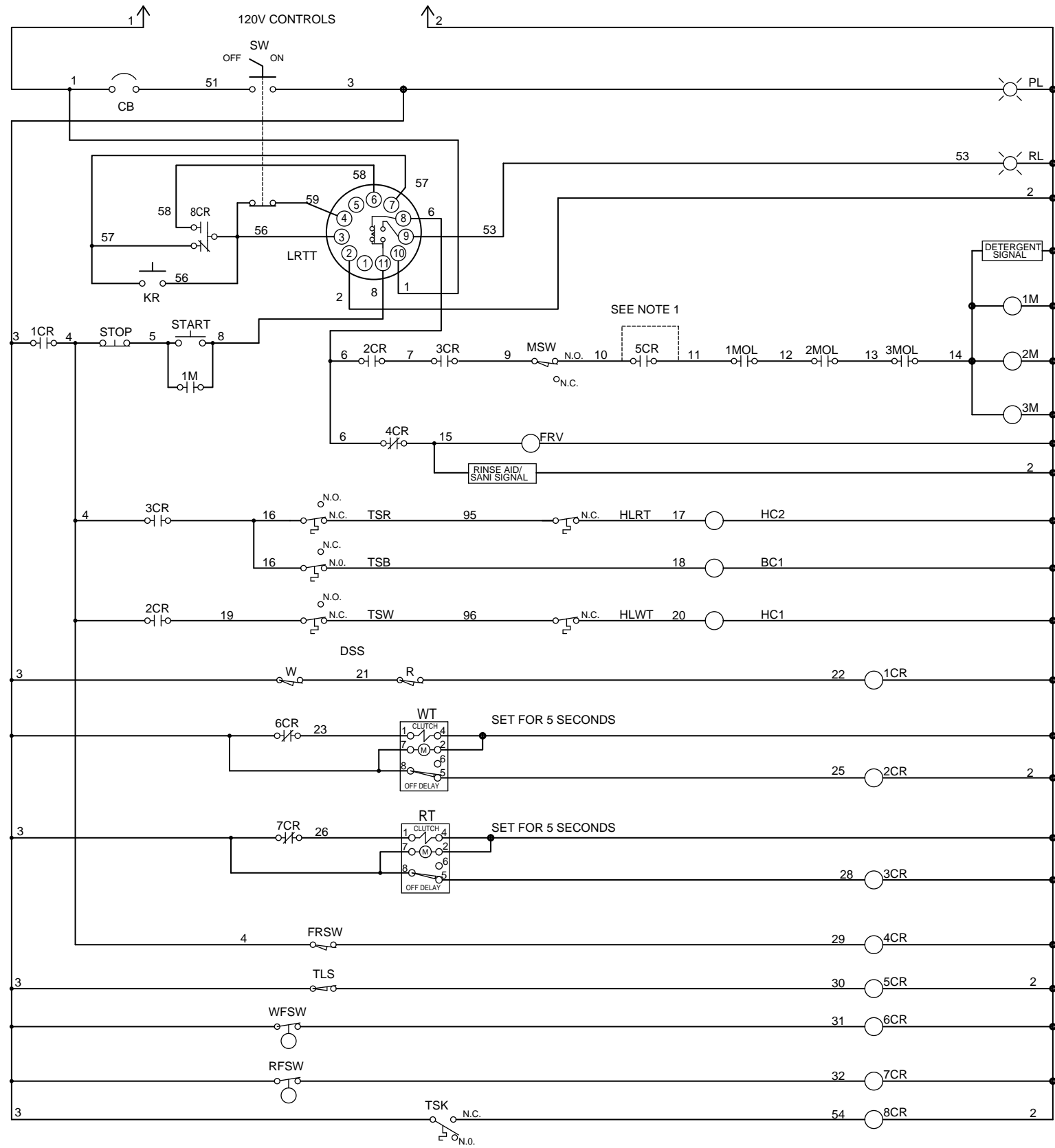

TO CUSTOMER
DISCONNECT SWITCH
FUSED FOR 15A MAX. AT
440/60/3.

!!!!!! WARNING !!!!
MULTIPLE POWER SOURCES ARE PRESENT
IN THIS CABINET. DISCONNECT ALL POWER
SOURCES PRIOR TO SERVICING.

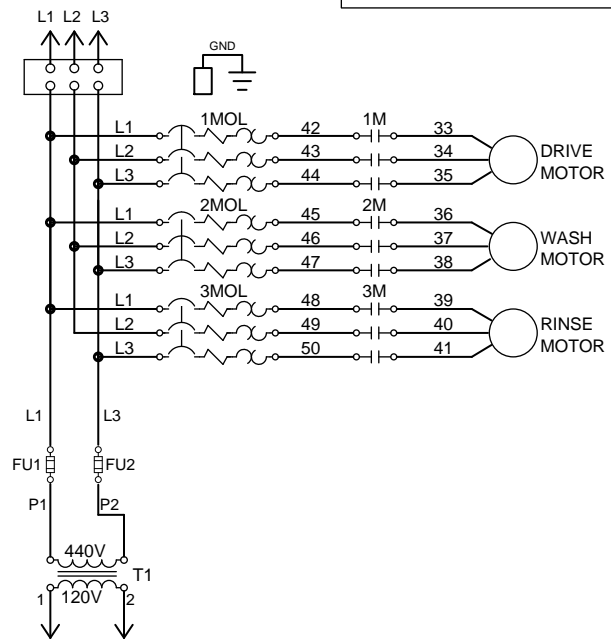

TO CUSTOMER
DISCONNECT SWITCH
FUSED FOR 35A MAX. AT
440/60/3.

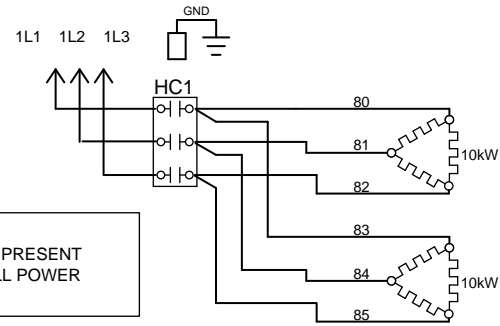

!!!!!! WARNING !!!!
MULTIPLE POWER SOURCES ARE PRESENT
IN THIS CABINET. DISCONNECT ALL POWER
SOURCES PRIOR TO SERVICING.

TO CUSTOMER
DISCONNECT SWITCH
FUSED FOR 50A MAX. AT
440/60/3.

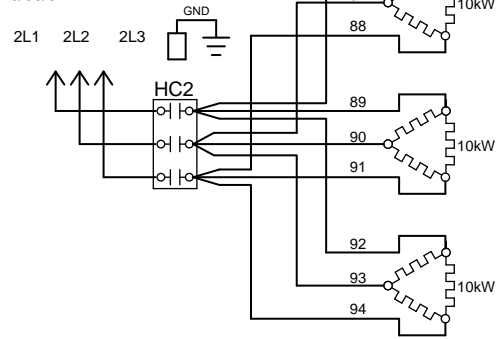

1CR	DOOR SAFETY SWITCH HOLD-IN RELAY
2CR	WASH TANK FLOAT HOLD-IN RELAY
3CR	RINSE TANK FLOAT HOLD-IN RELAY
4CR	FINAL RINSE SWITCH RELAY
5CR	TABLE LIMIT SWITCH RELAY
6CR	WASH TANK FLOAT SWITCH RELAY
7CR	RINSE TANK FLOAT SWITCH RELAY
8CR	LOW TEMP RELAY
1M	DRIVE CONTACTOR
1MOL	DRIVE MOTOR OVERLOAD
2M	WASH CONTACTOR
2MOL	WASH MOTOR OVERLOAD
3M	RINSE CONTACTOR
3MOL	RINSE MOTOR OVERLOAD
BC1	BOOSTER HEATER CONTACTOR
CB	CIRCUIT BREAKER
DSS	DOOR SAFETY SWITCH
FRSW	FINAL RINSE SWITCH
FRV	FINAL RINSE FILL VALVE
FU-	FUSE-TRANSFORMER
HC1	WASH TANK HEAT CONTACTOR
HC2	RINSE TANK HEAT CONTACTOR
HLRT	HIGH LIMIT RINSE TANK
HLWT	HIGH LIMIT WASH TANK
KR	KEYED RESET SWITCH
LRTT	LOW RINSE TEMPERATURE TIMER
MSW	MOTOR STOP SWITCH
PL	POWER ON LIGHT
RFSW	RINSE TANK FLOAT SWITCH
R	RINSE TANK DOOR SAFETY SWITCH
RL	RESET LIGHT
RT	RINSE TANK FLOAT TIMER
SW	POWER SWITCH
T1	440V:120V TRANSFORMER
TKL	LOW TEMP INDICATOR LIGHT
TLS	TABLE LIMIT SWITCH
TSB	BOOSTER THERMOSTAT
TSK	LOW TEMPERATURE CUT-OFF THERMOSTAT
TSR	RINSE TANK THERMOSTAT
TSW	WASH TANK THERMOSTAT
W	WASH TANK DOOR SAFETY SWITCH
WFSW	WASH TANK FLOAT SWITCH
WT	WASH TANK FLOAT TIMER

NOTES
1. REMOVE JUMPER ACROSS N.O. 5CR
CONTACT WHEN TABLE LIMIT SWITCH IS
USED.

DIAGRAM STATE
POWER OFF
DOORS CLOSED
TANKS EMPTY
END OF CYCLE

CUSTOMER TO SUPPLY RATED VOLTAGE/PHASE/Hz, AS SPECIFIED PER ORDER. TO DISCONNECT SWITCH, ALL POWER SUPPLIED TO EACH CONNECTION POINT MUST COMPLY WITH ALL LOCAL ELECTRIC CODES.			
DR.BY	J.NEWTON	SCALE	
DATE	18MAY98	SHEET	1 OF 1

REV.	DESCRIPTION	DATE	BY

REV.	DESCRIPTION	DATE	BY

Champion The Dishwashing Machine Specialists		USN-72 ELECTRIC	
		REV.	

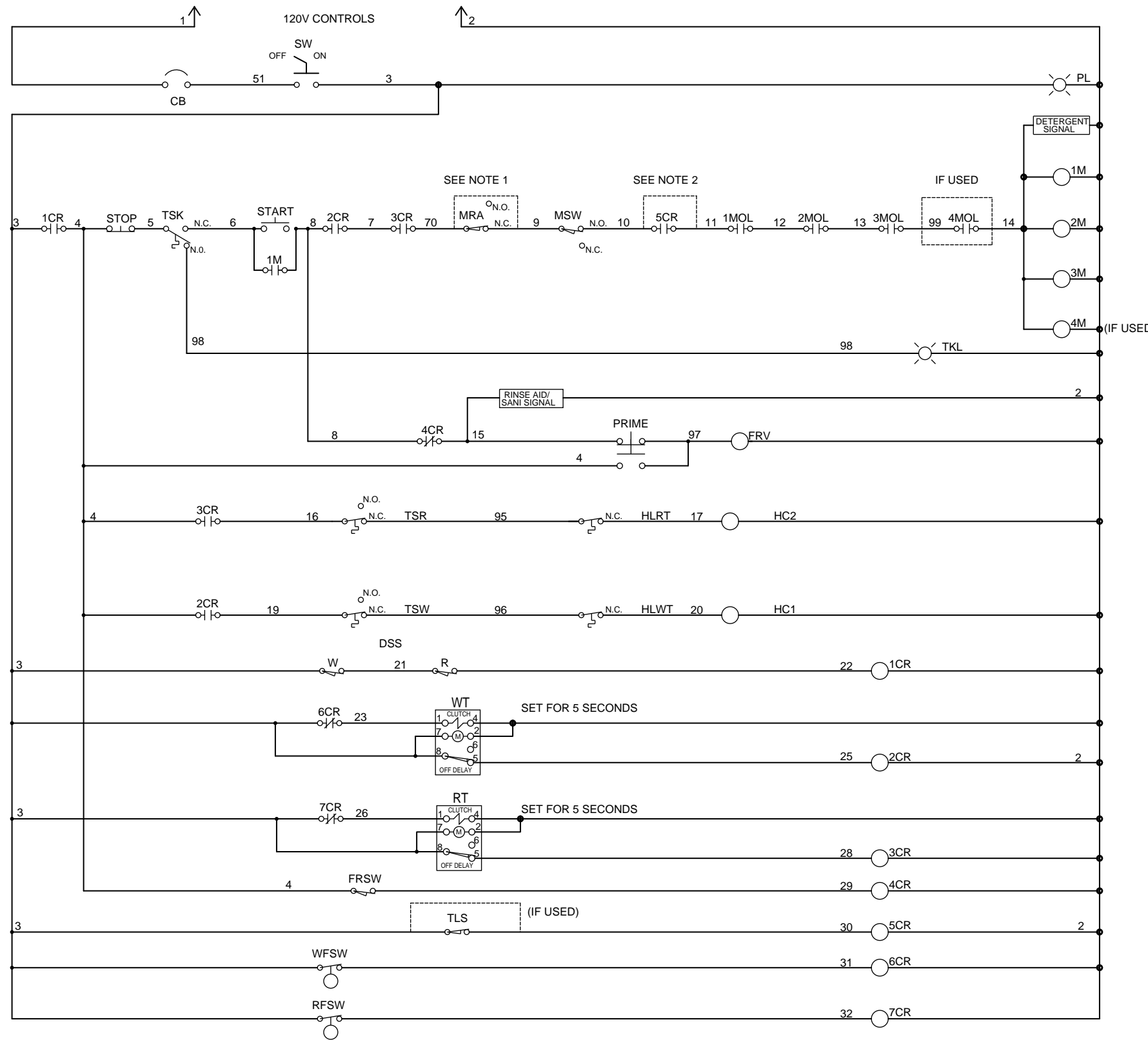

TO CUSTOMER DISCONNECT SWITCH FUSED FOR 50A MAX. AT 440/60/3.

!!!!!! WARNING !!!!
MULTIPLE POWER SOURCES ARE PRESENT IN THIS CABINET. DISCONNECT ALL POWER SOURCES PRIOR TO SERVICING.

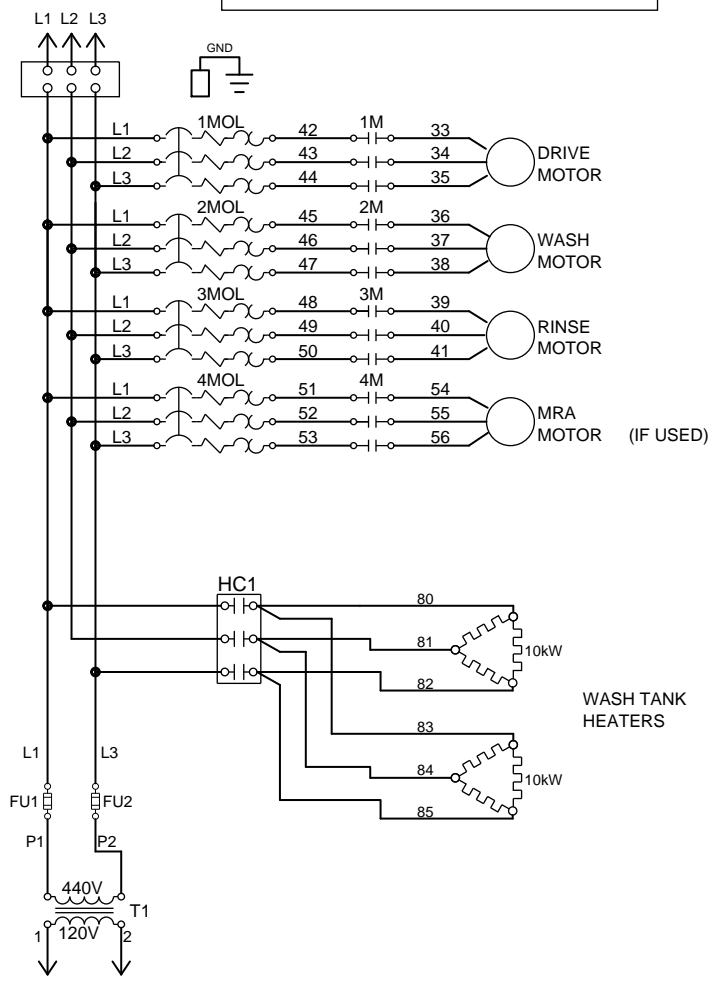

!!!!!! WARNING !!!!
MULTIPLE POWER SOURCES ARE PRESENT IN THIS CABINET. DISCONNECT ALL POWER SOURCES PRIOR TO SERVICING.

TO CUSTOMER DISCONNECT SWITCH FUSED FOR 50A MAX. AT 440/60/3.

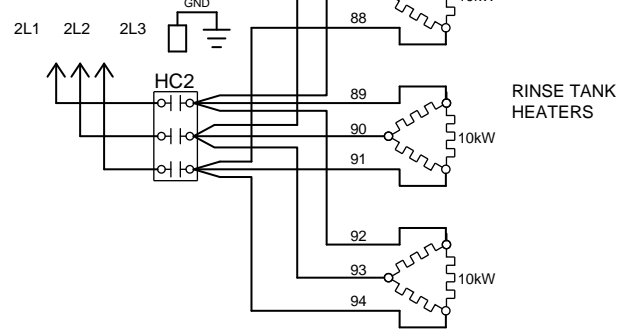

1CR	DOOR SAFETY SWITCH HOLD-IN RELAY
2CR	WASH TANK FLOAT HOLD-IN RELAY
3CR	RINSE TANK FLOAT HOLD-IN RELAY
4CR	FINAL RINSE SWITCH RELAY
5CR	TABLE LIMIT SWITCH RELAY
6CR	WASH TANK FLOAT SWITCH RELAY
7CR	RINSE TANK FLOAT SWITCH RELAY
1M	DRIVE CONTACTOR
1MOL	DRIVE MOTOR OVERLOAD
2M	WASH CONTACTOR
2MOL	WASH MOTOR OVERLOAD
3M	RINSE CONTACTOR
3MOL	RINSE MOTOR OVERLOAD
4M	MRA CONTACTOR
4MOL	MRA MOTOR OVERLOAD
BC1	BOOSTER HEATER CONTACTOR
CB	CIRCUIT BREAKER
DSS	DOOR SAFETY SWITCH
FRSW	FINAL RINSE SWITCH
FRV	FINAL RINSE FILL VALVE
FU-	FUSE-TRANSFORMER
HC1	WASH TANK HEAT CONTACTOR
HC2	RINSE TANK HEAT CONTACTOR
HLRT	HIGH LIMIT RINSE TANK
HLWT	HIGH LIMIT WASH TANK
KR	KEYED RESET SWITCH
LRTT	LOW RINSE TEMPERATURE TIMER
MSW	MOTOR STOP SWITCH
MRA	MACHINE RACK ADVANCE LIMIT SWITCH
PL	POWER ON LIGHT
RFSW	RINSE TANK FLOAT SWITCH
R	RINSE TANK DOOR SAFETY SWITCH
RL	RESET LIGHT
RT	RINSE TANK FLOAT TIMER
SW	POWER SWITCH
T1	440V:120V TRANSFORMER
TKL	LOW TEMP INDICATOR LIGHT
TLS	TABLE LIMIT SWITCH
TSB	BOOSTER THERMOSTAT
TSK	LOW TEMPERATURE CUT-OFF THERMOSTAT
TSR	RINSE TANK THERMOSTAT
TSW	WASH TANK THERMOSTAT
W	WASH TANK DOOR SAFETY SWITCH
WFSW	WASH TANK FLOAT SWITCH
WT	WASH TANK FLOAT TIMER

NOTES

1. REMOVE JUMPER ACROSS WIRES 70 AND 9 WHEN RACK ADVANCE TABLE IS USED.
2. REMOVE JUMPER ACROSS N.O. 5CR CONTACT WHEN TABLE LIMIT SWITCH IS USED.

DIAGRAM STATE
POWER OFF
DOORS CLOSED
TANKS EMPTY
END OF CYCLE

CUSTOMER TO SUPPLY RATED VOLTAGE/PHASE/Hz, AS SPECIFIED PER ORDER, TO DISCONNECT SWITCH. ALL POWER SUPPLIED TO EACH CONNECTION POINT MUST COMPLY WITH ALL LOCAL ELECTRIC CODES.

DR.BY	J.NEWTON	SCALE	
DATE	23MAR00	SHEET	1 OF 1

REV.	DESCRIPTION	DATE	BY
A	TANK HEAT ADDED TO MOTORS AND CONTROL CIRCUIT	6JUNE00	JCN
B	MRA TO BE NC IN NORMAL POSITION	16OCT00	JCN

REV.	DESCRIPTION	DATE	BY

Champion
The Dishwashing Machine Specialists

USN-72 ELECTRIC
B 701697 REV. B

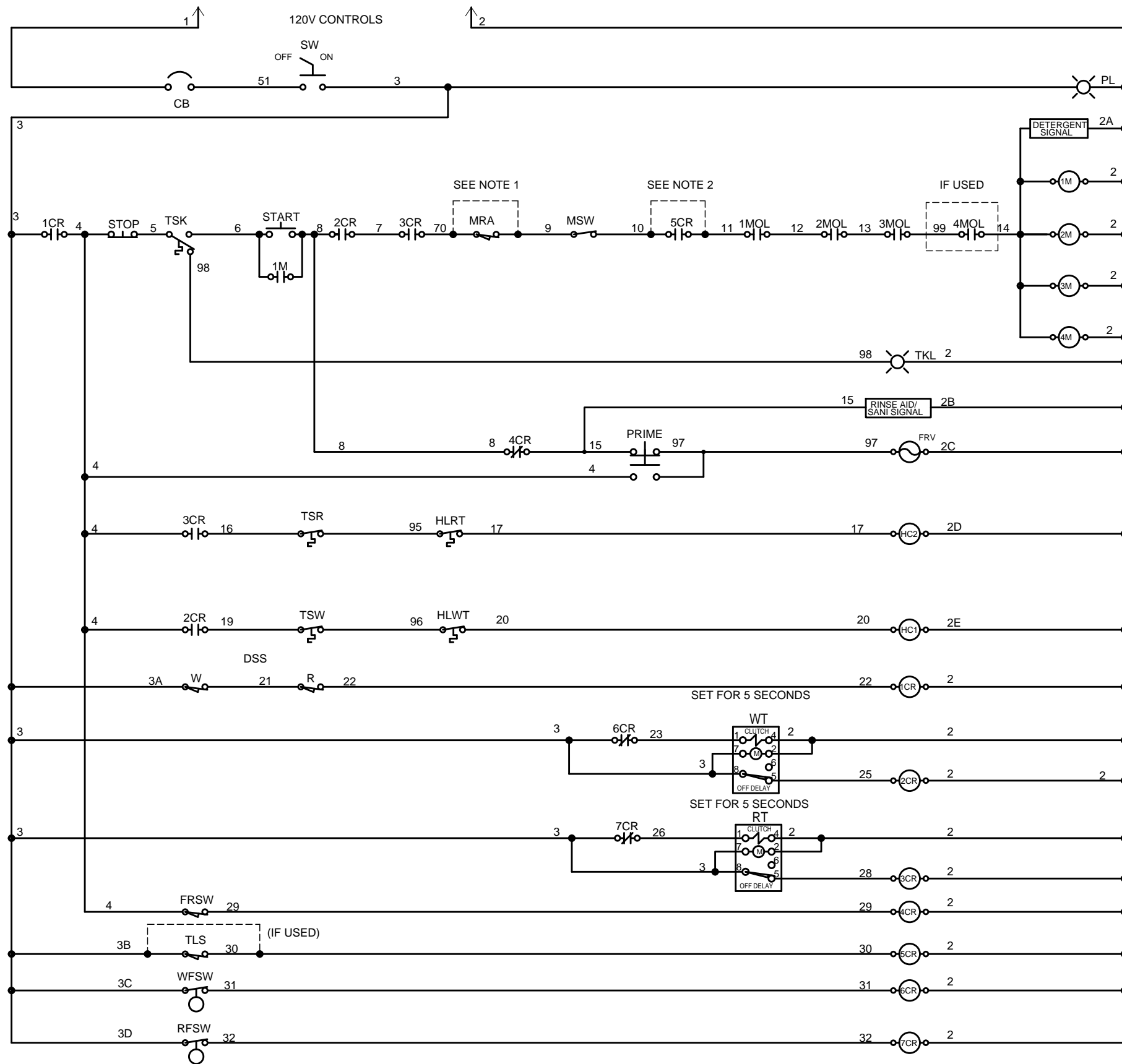

TO CUSTOMER DISCONNECT SWITCH FUSED FOR 50A MAX. AT 440/60/3.

!!!!!! WARNING !!!!!
MULTIPLE POWER SOURCES ARE PRESENT IN THIS CABINET. DISCONNECT ALL POWER SOURCES PRIOR TO SERVICING.

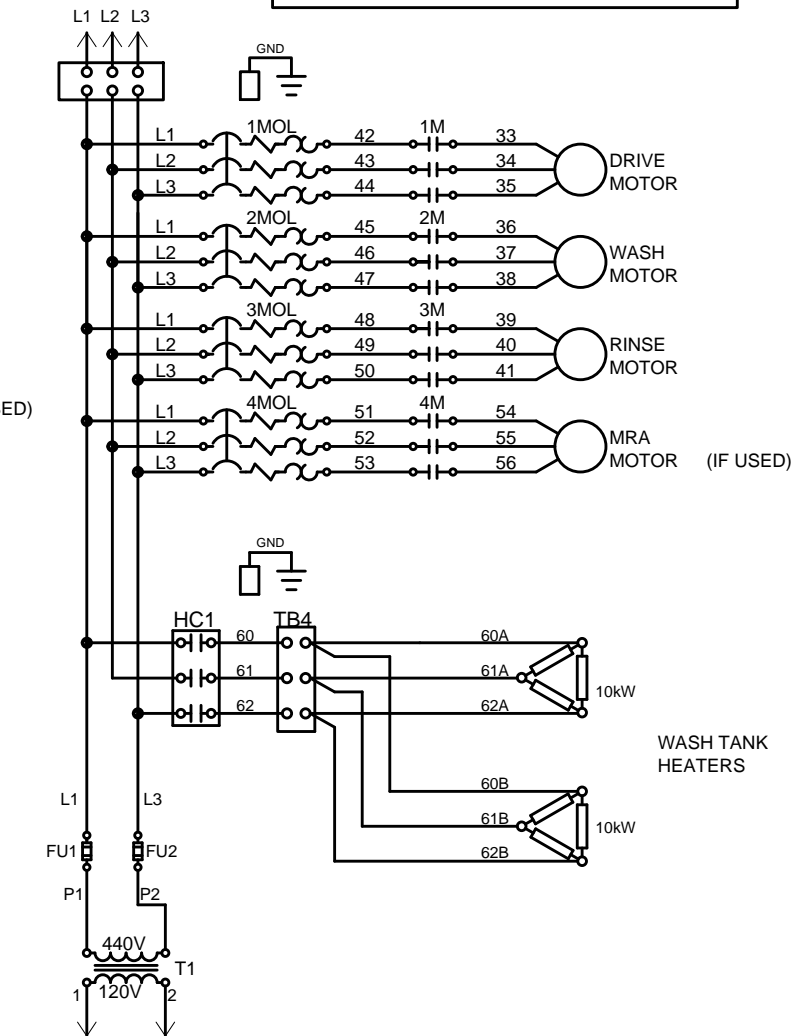

!!!!!! WARNING !!!!!
MULTIPLE POWER SOURCES ARE PRESENT IN THIS CABINET. DISCONNECT ALL POWER SOURCES PRIOR TO SERVICING.

TO CUSTOMER DISCONNECT SWITCH FUSED FOR 50A MAX. AT 440/60/3.

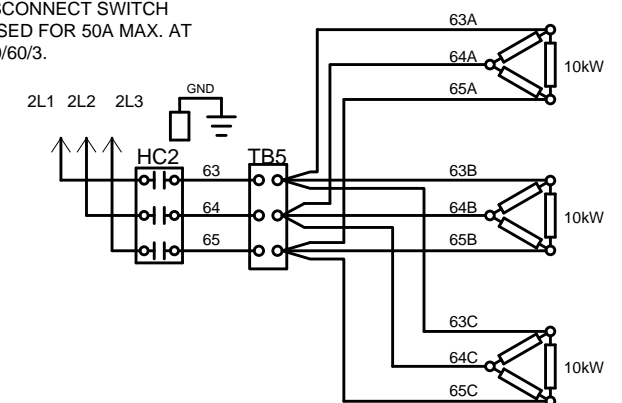

DIAGRAM STATE
POWER OFF
DOORS CLOSED
TANKS EMPTY
END OF CYCLE

* PARTS LOCATED IN CONTROL PANEL

1CR	* DOOR SAFETY SWITCH HOLD-IN RELAY
2CR	* WASH TANK FLOAT HOLD-IN RELAY
3CR	* RINSE TANK FLOAT HOLD-IN RELAY
4CR	* FINAL RINSE SWITCH RELAY
5CR	* TABLE LIMIT SWITCH RELAY
6CR	* WASH TANK FLOAT SWITCH RELAY
7CR	* RINSE TANK FLOAT SWITCH RELAY
1M	* DRIVE CONTACTOR
1MOL	* DRIVE MOTOR OVERLOAD
2M	* WASH CONTACTOR
2MOL	* WASH MOTOR OVERLOAD
3M	* RINSE CONTACTOR
3MOL	* RINSE MOTOR OVERLOAD
4M	* MRA CONTACTOR
4MOL	* MRA MOTOR OVERLOAD
BC1	* BOOSTER HEATER CONTACTOR
CB	* CIRCUIT BREAKER
DSS	* DOOR SAFETY SWITCH
FRSW	* FINAL RINSE SWITCH
FRV	* FINAL RINSE FILL VALVE
FU-	* FUSE-TRANSFORMER
HC1	* WASH TANK HEAT CONTACTOR
HC2	* RINSE TANK HEAT CONTACTOR
HLRT	* HIGH LIMIT RINSE TANK
HLWT	* HIGH LIMIT WASH TANK
MSW	* MOTOR STOP SWITCH
MRA	* MACHINE RACK ADVANCE LIMIT SWITCH
PL	* POWER ON LIGHT
RFSW	* RINSE TANK FLOAT SWITCH
R	* RINSE TANK DOOR SAFETY SWITCH
RT	* RINSE TANK FLOAT TIMER
SW	* POWER SWITCH
T1	* 440V:120V TRANSFORMER
TB6	* WASH HEATER TERMINAL BLOCK
TB7	* RINSE HEATER TERMINAL BLOCK
TKL	* LOW TEMP INDICATOR LIGHT
TLS	* TABLE LIMIT SWITCH
TSB	* BOOSTER THERMOSTAT
TSK	* LOW TEMPERATURE CUT-OFF THERMOSTAT
TSR	* RINSE TANK THERMOSTAT
TSW	* WASH TANK THERMOSTAT
W	* WASH TANK DOOR SAFETY SWITCH
WFSW	* WASH TANK FLOAT SWITCH
WT	* WASH TANK FLOAT TIMER

- NOTES
1. REMOVE JUMPER ACROSS WIRES 70 AND 9 WHEN RACK ADVANCE TABLE IS USED.
 2. REMOVE JUMPER ACROSS N.O. 5CR CONTACT WHEN TABLE LIMIT SWITCH IS USED.

CUSTOMER TO SUPPLY RATED VOLTAGE/PHASE/Hz, AS SPECIFIED PER ORDER, TO DISCONNECT SWITCH. ALL POWER SUPPLIED TO EACH CONNECTION POINT MUST COMPLY WITH ALL LOCAL ELECTRIC CODES.

DR. BY	J. NEWTON	SCALE	
DATE	23MAR00	SHEET	1 OF 1

REV.	DESCRIPTION	DATE	BY
A	TANK HEAT ADDED TO MOTORS AND CONTROL CIRCUIT	6JUNE00	JCN
B	MRA TO BE NC IN NORMAL POSITION	18OCT00	JCN
C	CHANGED WIRE NUMBERS TO MATCH TERMINAL BLOCKS	06OCT03	JAM

REV.	DESCRIPTION	DATE	BY

Champion

The Dishwashing Machine Specialists

USN-72

ELECTRIC

B 701697

REV. **C**

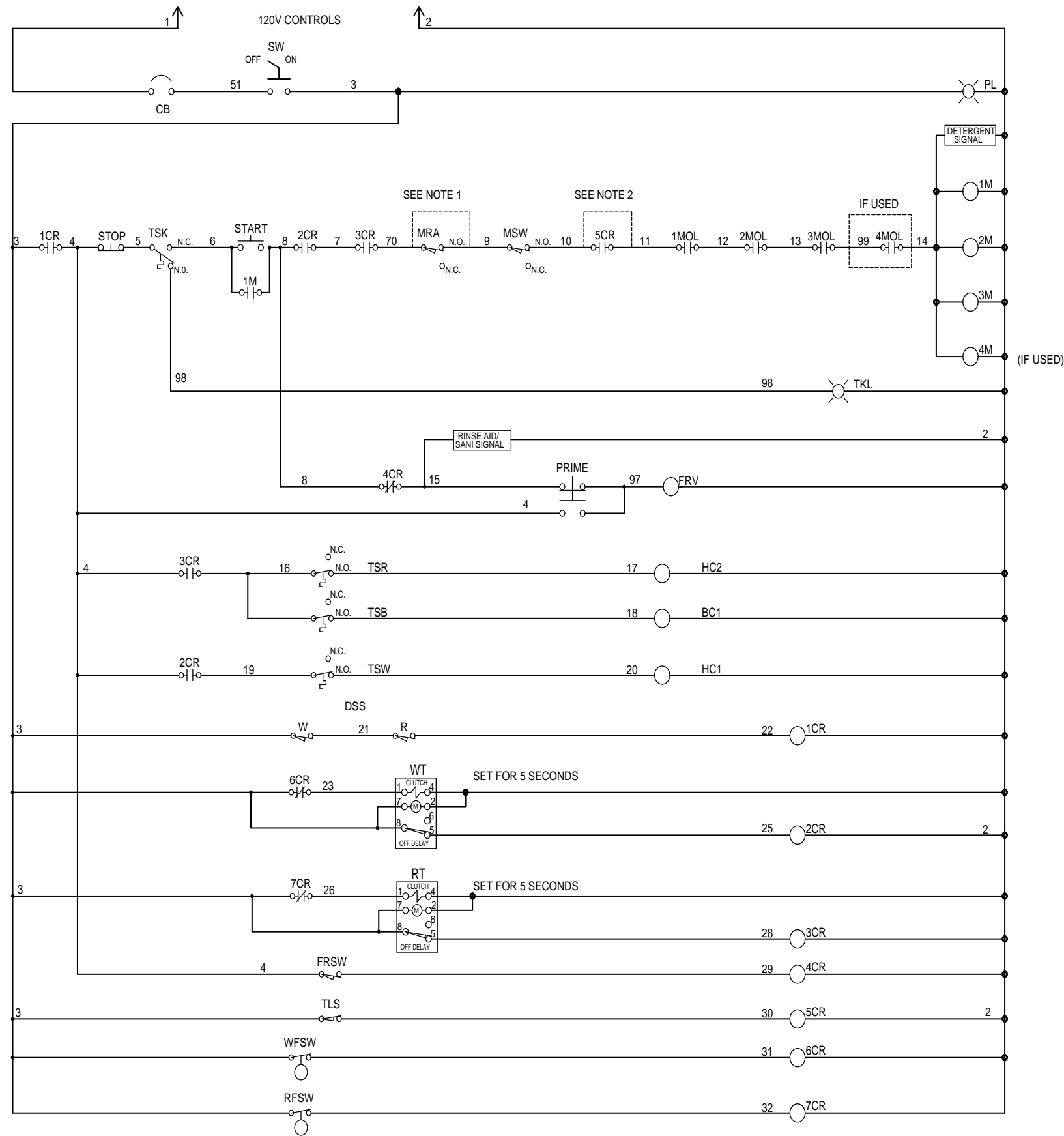

TO CUSTOMER
DISCONNECT SWITCH
FUSED FOR 15A MAX. AT
440/60/3.

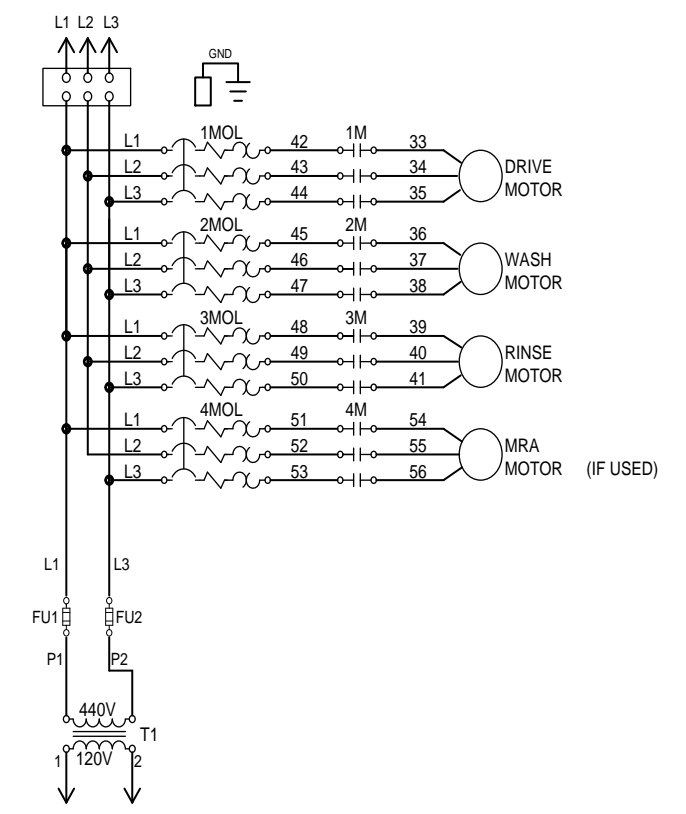

1CR	DOOR SAFETY SWITCH HOLD-IN RELAY	HC1	WASH TANK HEAT STEAM VALVE
2CR	WASH TANK FLOAT HOLD-IN RELAY	HC2	RINSE TANK HEAT STEAM VALVE
3CR	RINSE TANK FLOAT HOLD-IN RELAY	MRA	MRA MOTOR STOP SWITCH (IF USED)
4CR	FINAL RINSE SWITCH RELAY	MSW	MOTOR STOP SWITCH
5CR	TABLE LIMIT SWITCH RELAY	PL	POWER ON LIGHT
6CR	WASH TANK FLOAT SWITCH RELAY	RFSW	RINSE TANK FLOAT SWITCH
7CR	RINSE TANK FLOAT SWITCH RELAY	R	RINSE TANK DOOR SAFETY SWITCH
1M	DRIVE CONTACTOR	RT	RINSE TANK FLOAT TIMER
1MOL	DRIVE MOTOR OVERLOAD	SW	POWER SWITCH
2M	WASH CONTACTOR	T1	440V:120V TRANSFORMER
2MOL	WASH MOTOR OVERLOAD	TKL	LOW TEMP INDICATOR LIGHT
3M	RINSE CONTACTOR	TLS	TABLE LIMIT SWITCH (IF USED)
3MOL	RINSE MOTOR OVERLOAD	TSB	BOOSTER THERMOSTAT
4M	MRA MOTOR CONTACTOR (IF USED)	TSK	LOW TEMPERATURE CUT-OFF THERMOSTAT
4MOL	MRA MOTOR OVERLOAD (IF USED)	TSR	RINSE TANK THERMOSTAT
BC1	BOOSTER HEATER STEAM VALVE	TSW	WASH TANK THERMOSTAT
CB	CIRCUIT BREAKER	W	WASH TANK DOOR SAFETY SWITCH
DSS	DOOR SAFETY SWITCH	WFSW	WASH TANK FLOAT SWITCH
FRSW	FINAL RINSE SWITCH	WT	WASH TANK FLOAT TIMER
FRV	FINAL RINSE VALVE		
FU-	FUSE-TRANSFORMER		

NOTES

1. REMOVE JUMPER ACROSS WIRES 70 AND 9 WHEN RACK ADVANCE TABLE IS USED.
2. REMOVE JUMPER ACROSS N.O. 5CR CONTACT WHEN TABLE LIMIT SWITCH IS USED.

DIAGRAM STATE
POWER OFF
DOORS CLOSED
TANKS EMPTY
END OF CYCLE

CUSTOMER TO SUPPLY RATED VOLTAGE/PHASE/Hz, AS SPECIFIED PER ORDER, TO DISCONNECT SWITCH. ALL POWER SUPPLIED TO EACH CONNECTION POINT MUST COMPLY WITH ALL LOCAL ELECTRIC CODES.

DR. BY	J. NEWTON	SCALE	
DATE	12JUNE00	SHEET	1 OF 1

REV.	DESCRIPTION	DATE	BY
A	REVISED THERMOSTAT CONTACT LOGIC	13JULY00	JCN

REV.	DESCRIPTION	DATE	BY

Champion
The Dishwashing Machine Specialists

USN-72 STEAM
B 701700 REV. A

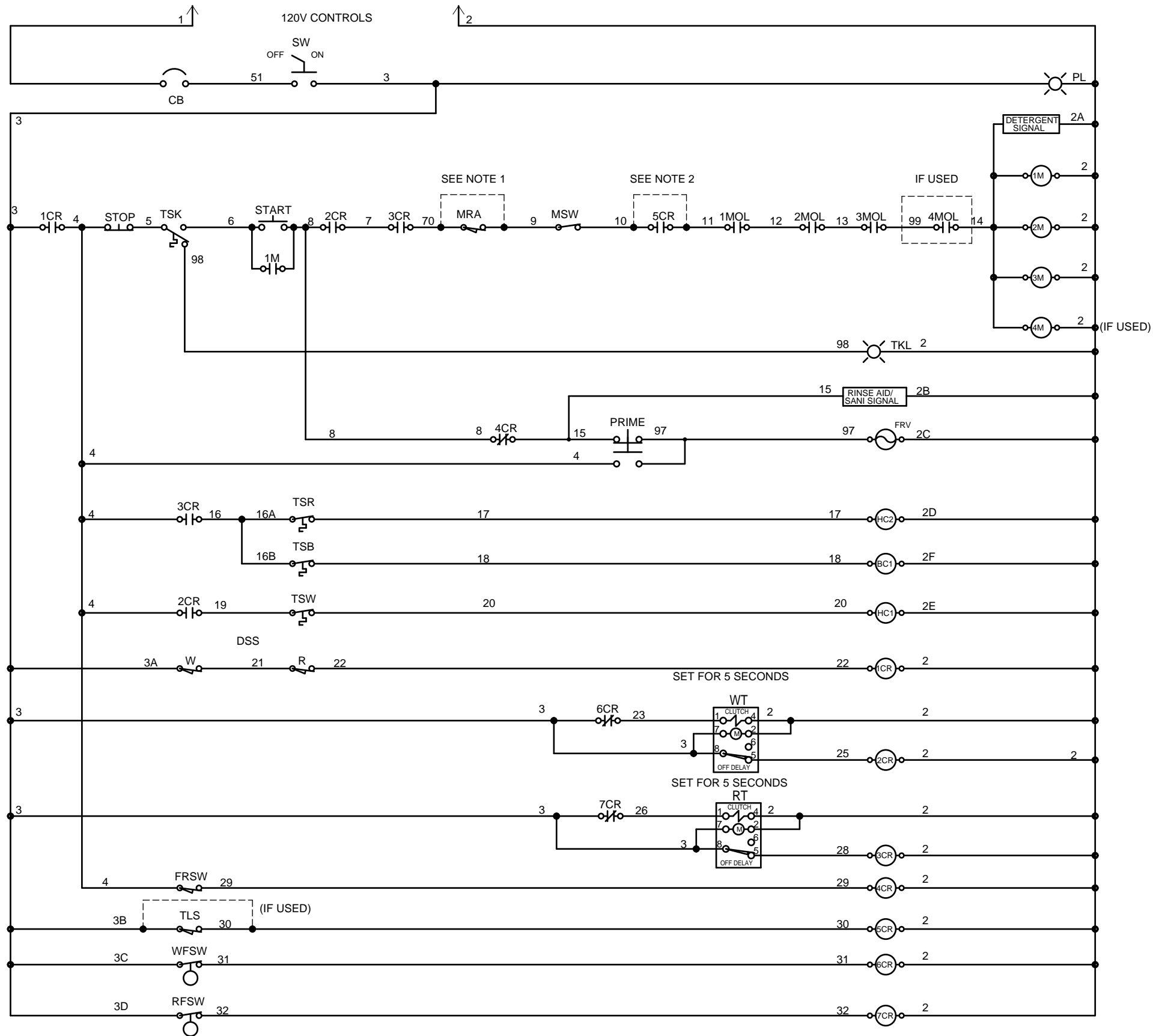

TO CUSTOMER
DISCONNECT SWITCH
FUSED FOR 15A MAX. AT
440/60/3.

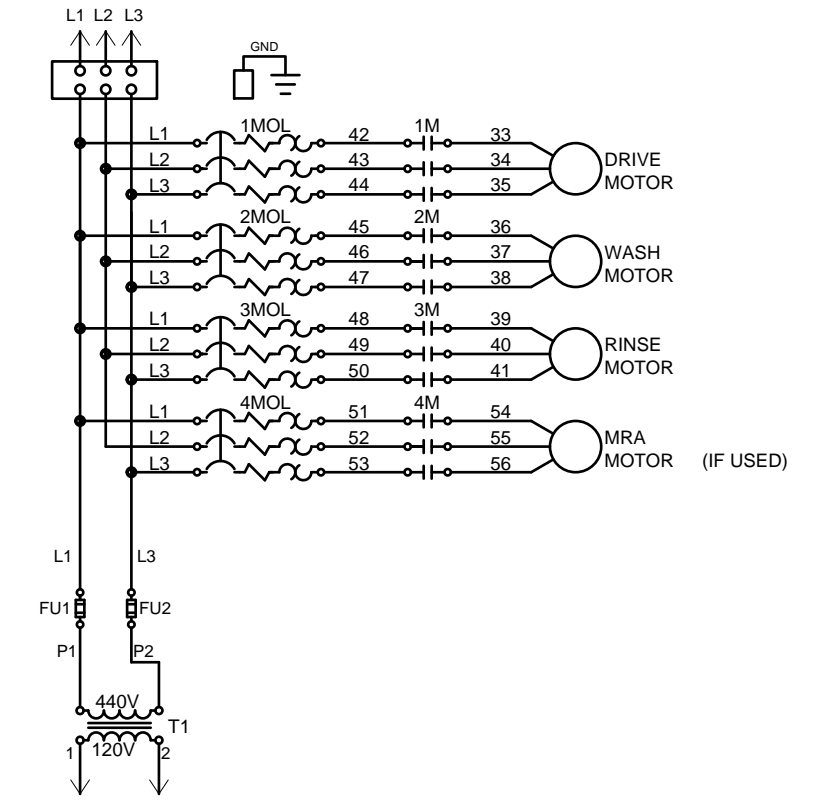

1CR	DOOR SAFETY SWITCH HOLD-IN RELAY	HC1	WASH TANK HEAT STEAM VALVE
2CR	WASH TANK FLOAT HOLD-IN RELAY	HC2	RINSE TANK HEAT STEAM VALVE
3CR	RINSE TANK FLOAT HOLD-IN RELAY	MRA	MRA MOTOR STOP SWITCH (IF USED)
4CR	FINAL RINSE SWITCH RELAY	MSW	MOTOR STOP SWITCH
5CR	TABLE LIMIT SWITCH RELAY	PL	POWER ON LIGHT
6CR	WASH TANK FLOAT SWITCH RELAY	RFSW	RINSE TANK FLOAT SWITCH
7CR	RINSE TANK FLOAT SWITCH RELAY	R	RINSE TANK DOOR SAFETY SWITCH
1M	DRIVE CONTACTOR	RT	RINSE TANK FLOAT TIMER
1MOL	DRIVE MOTOR OVERLOAD	SW	POWER SWITCH
2M	WASH CONTACTOR	T1	440V:120V TRANSFORMER
2MOL	WASH MOTOR OVERLOAD	TKL	LOW TEMP INDICATOR LIGHT
3M	RINSE CONTACTOR	TLS	TABLE LIMIT SWITCH (IF USED)
3MOL	RINSE MOTOR OVERLOAD	TSB	BOOSTER THERMOSTAT
4M	MRA MOTOR CONTACTOR (IF USED)	TSK	LOW TEMPERATURE CUT-OFF THERMOSTAT
4MOL	MRA MOTOR OVERLOAD (IF USED)	TSR	RINSE TANK THERMOSTAT
BC1	BOOSTER HEATER STEAM VALVE	TSW	WASH TANK THERMOSTAT
CB	CIRCUIT BREAKER	W	WASH TANK DOOR SAFETY SWITCH
DSS	DOOR SAFETY SWITCH	WFSW	WASH TANK FLOAT SWITCH
FRSW	FINAL RINSE SWITCH	WT	WASH TANK FLOAT TIMER
FRV	FINAL RINSE VALVE		
FU	FUSE-TRANSFORMER		

NOTES

1. REMOVE JUMPER ACROSS WIRES 70 AND 9 WHEN RACK ADVANCE TABLE IS USED.

2. REMOVE JUMPER ACROSS N.O. 5CR CONTACT WHEN TABLE LIMIT SWITCH IS USED.

DIAGRAM STATE
POWER OFF
DOORS CLOSED
TANKS EMPTY
END OF CYCLE

CUSTOMER TO SUPPLY RATED VOLTAGE/PHASE/Hz, AS SPECIFIED PER ORDER, TO DISCONNECT SWITCH. ALL POWER SUPPLIED TO EACH CONNECTION POINT MUST COMPLY WITH ALL LOCAL ELECTRIC CODES.			
DR. BY	J. NEWTON	SCALE	
DATE	12JUNE00	SHEET	1 OF 1

REV.	DESCRIPTION	DATE	BY
A	REVISED THERMOSTAT CONTACT LOGIC	13JULY00	JCN
B	REVISED SYMBOLS AND WIRE NUMBERS	23OCT03	JAM

REV.	DESCRIPTION	DATE	BY

Champion
The Dishwashing Machine Specialists

USN-72 STEAM		
B	701700	REV. B

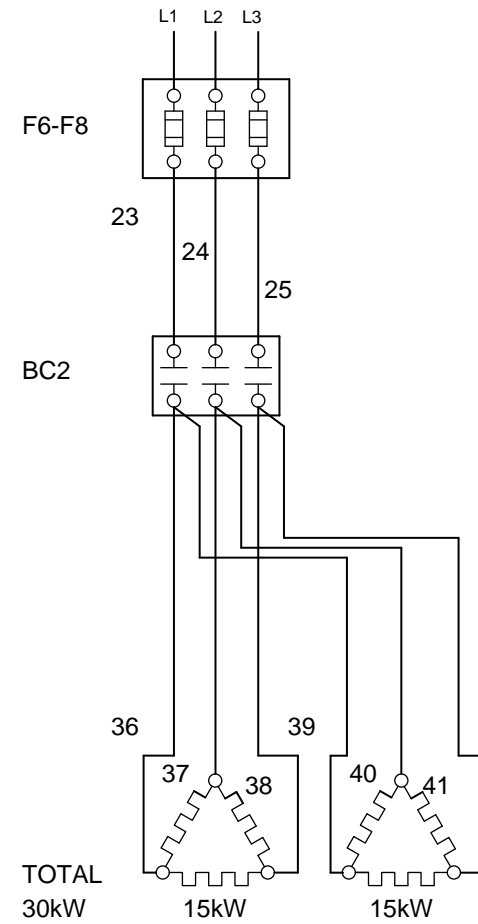
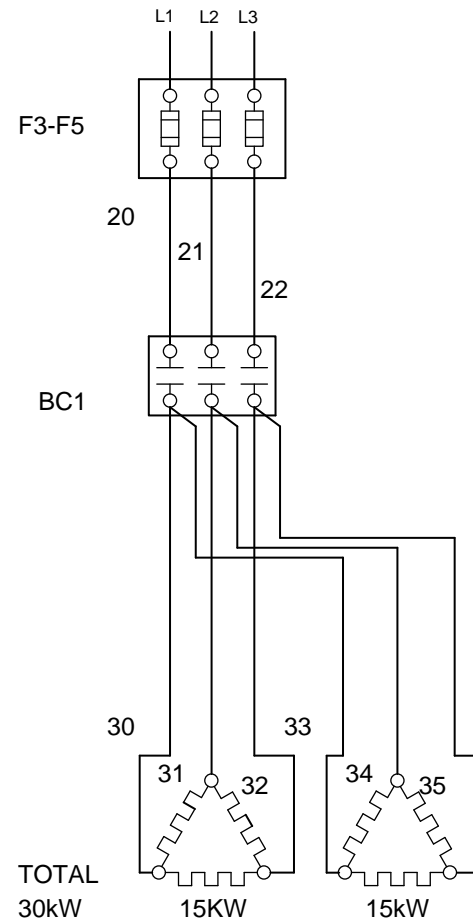
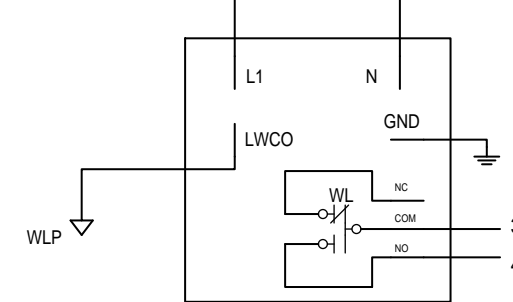
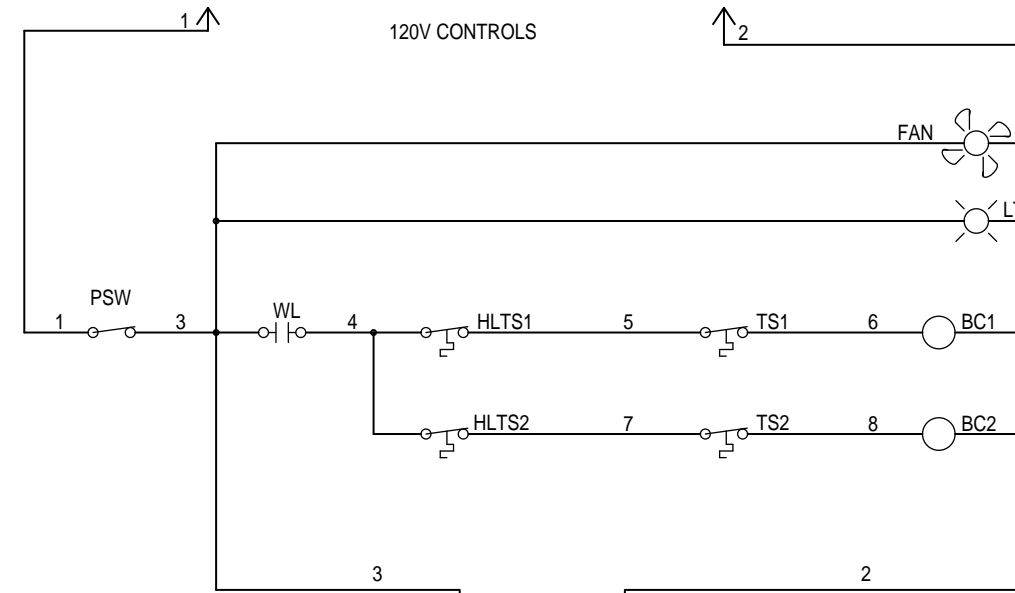
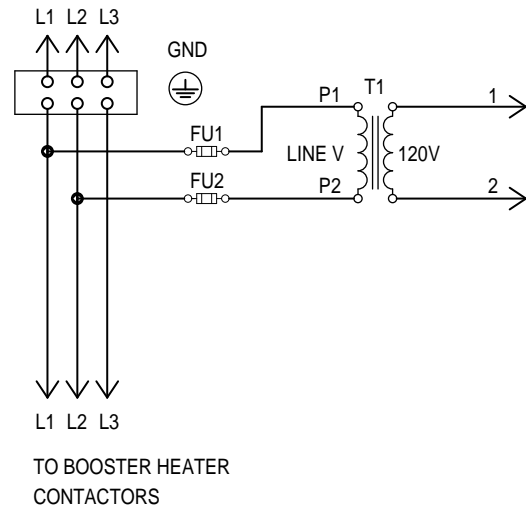

BC_	BOOSTER CONTACTOR
FU_	FUSE
HLTS_	HIGH LIMIT THERMOSTAT
LT	POWER ON LIGHT
LWCO	LOW WATER CUT-OUT PROBE
PSW	POWER SWITCH
TS_	THERMOSTAT
WL	WATER LEVEL BOARD N.O. CONTACT
WLP	WATER LEVEL PROBE

CUSTOMER TO SUPPLY RATED VOLTAGE/PHASE/Hz, AS SPECIFIED PER ORDER, TO DISCONNECT SWITCH. ALL POWER SUPPLIED TO EACH CONNECTION POINT MUST COMPLY WITH ALL LOCAL ELECTRIC CODES.			
DR. BY	J. NEWTON	SCALE	
DATE	5JUNE00	SHEET	1 OF 1

REV.	DESCRIPTION	DATE	BY
A	ADDED WIRES 3 & 4 REF TO WL CONTROL BOARD	20JULY00	JCN
B	REMOVED BC3 REFERENCES	17AUG00	JCN
C	ADDED COOLING FAN TO CABINET	18OCT00	JCN

 The Dishwashing Machine Specialists	CH-60 NAVY 60 KW BOOSTER-2 CANISTER	
	B	701709
	REV. C	

STEAM HEAT MODELS

CONNECTION #1
CUSTOMER SUPPLIED
440/60/3
15A AT 90°C
MIN. WIRE RATING

MAIN CONTROL
CABINET REMOTELY
LOCATED

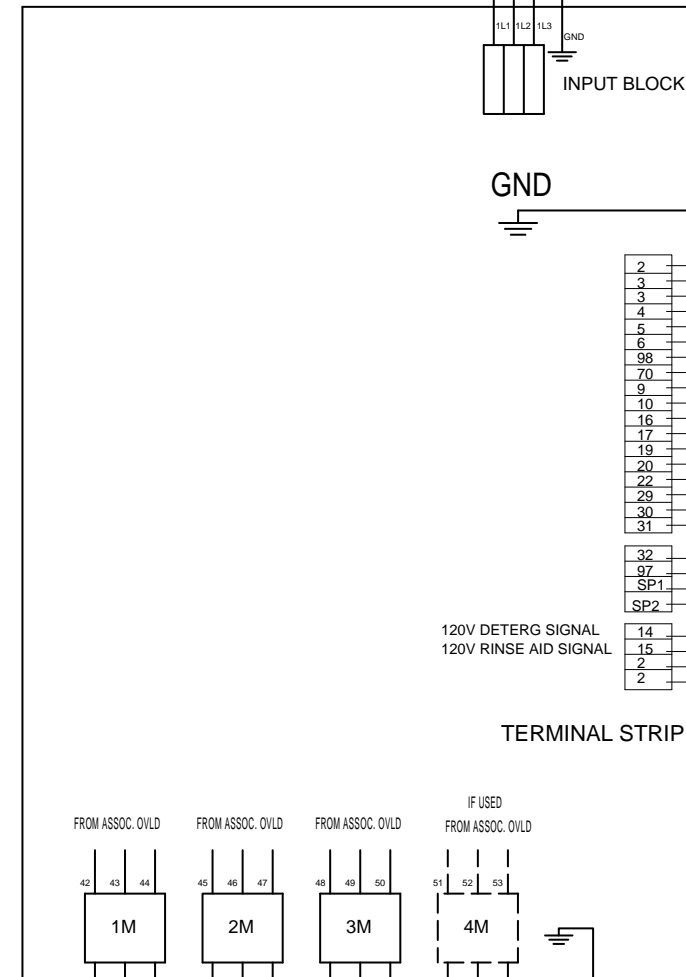

15A AT 90°C
MIN. WIRE RATING

3 - WHITE WIRES
NUMBERED 2 FOR 120V
NEUTRAL

1 - GREEN FOR GROUND

20 - WIRES FOR
CONTROL CIRCUIT
NUMBERED 3, 3, 4, 5, 6,
98, 9, 10, 16, 17, 19, 20,
22, 29, 30, 31, 32, 97, SP1,
SP2, 14, AND 15.

ADD ONE CONTROL
WIRE NUMBERED 70 FOR
MODELS WITH OPTIONAL
MRA TABLE

15A AT 90°C
MIN. WIRE RATING

3 - GREEN WIRES FOR
GROUND

9 - WIRES FOR MOTOR
WIRING NUMBERED 33-
41

ADD 3 MOTOR WIRES
NUMBERED 54-56 AND 1
GREEN WIRE FOR
MODELS WITH OPTIONAL
MRA TABLE

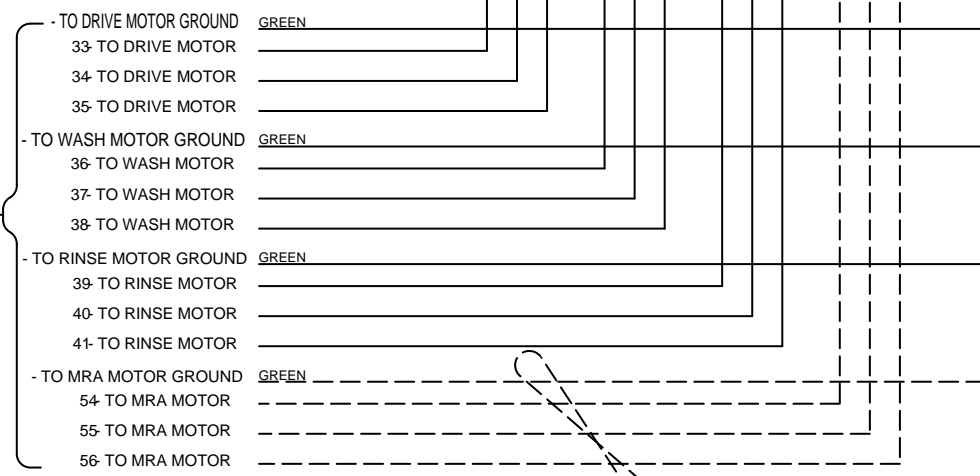

CUSTOMER TO SUPPLY RATED VOLTAGE/PHASE/Hz, AS SPECIFIED PER ORDER, TO DISCONNECT SWITCH. ALL POWER SUPPLIED TO EACH CONNECTION POINT MUST COMPLY WITH ALL LOCAL ELECTRIC CODES.			
DR. BY	J. NEWTON	SCALE	NONE
DATE	5MAR01	SHEET	1 OF 1

REV.	DESCRIPTION	DATE	BY

REV.	DESCRIPTION	DATE	BY

Champion
The Dishwashing Machine Specialists

USN-72 STEAM WIRING INTERCONNECTIONS		
B	B701728	REV.

STEAM HEAT MODELS

CONNECTION #1
CUSTOMER SUPPLIED
440/60/3
15A AT 90°C
MIN. WIRE RATING

MAIN CONTROL
CABINET REMOTELY
LOCATED

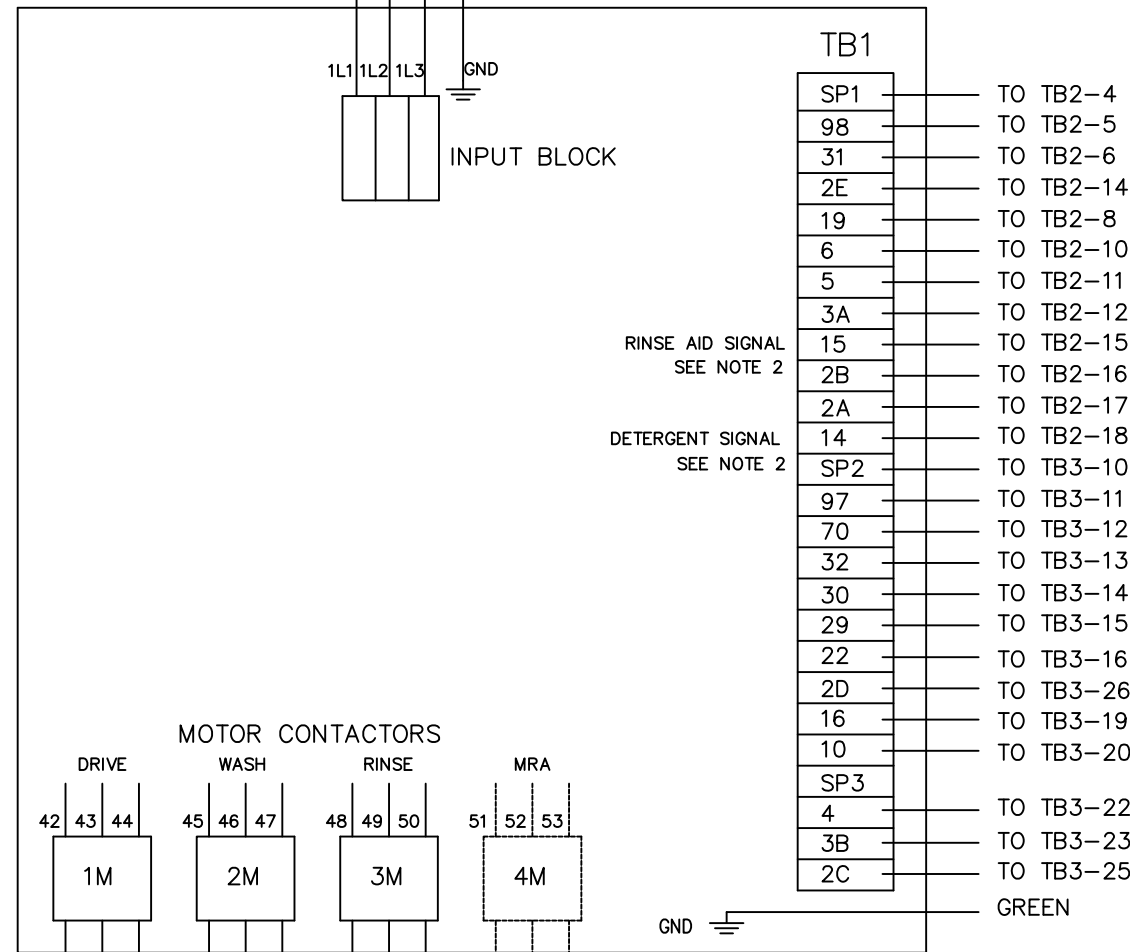

TO TB2
SEE NOTE 1

TO TB3
SEE NOTE 1

TB2 AND TB3 LOCATED IN WIREWAYS ON FRONT OF TANKS

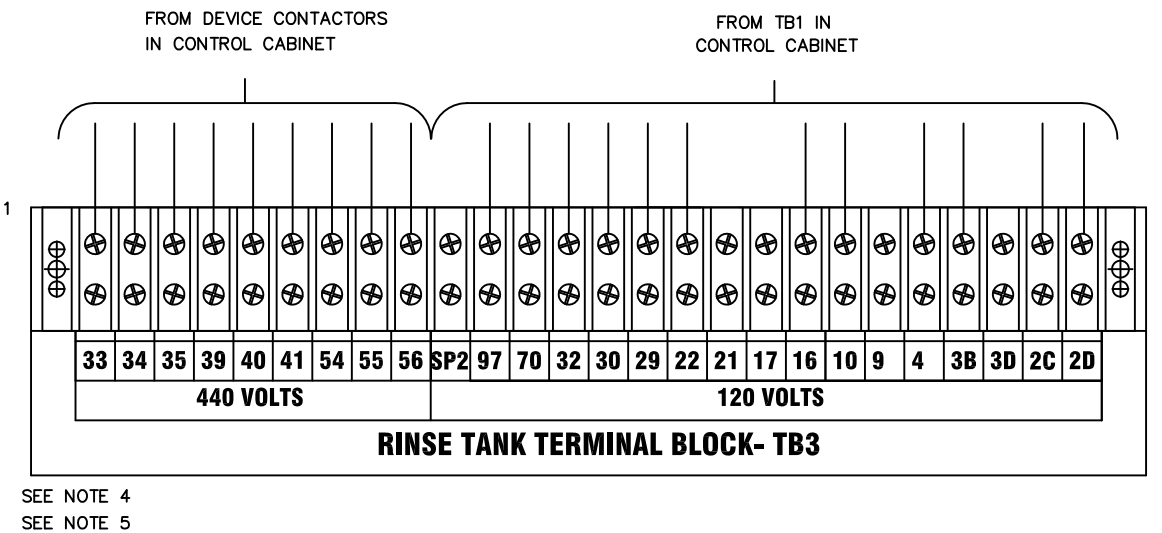
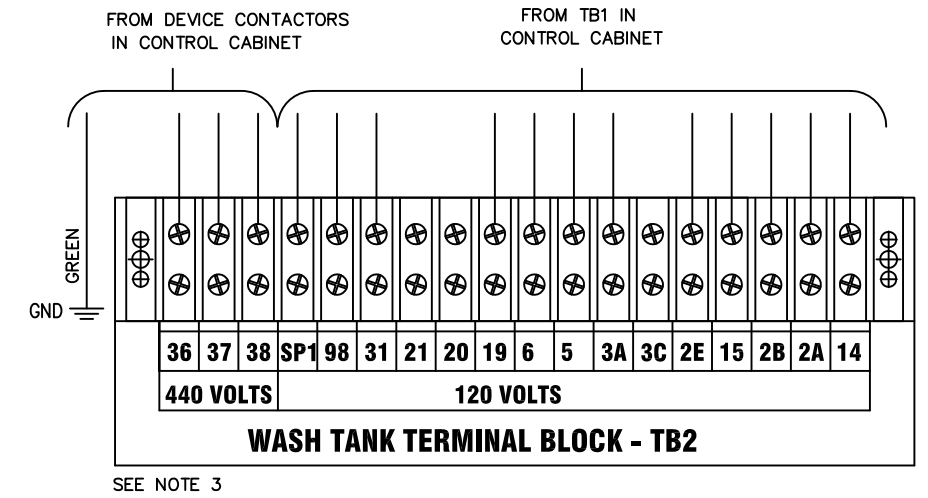

15A AT 90°C
MIN. WIRE RATING

9 - WIRES FOR MOTOR
WIRING NUMBERED 33-41
ADD 3 MOTOR WIRES
NUMBERED 54-56 FOR
MODELS WITH OPTIONAL
MRA TABLE. SEE
TERMINAL BLOCK TB-2
AND TB-3 DETAIL AT
RIGHT.

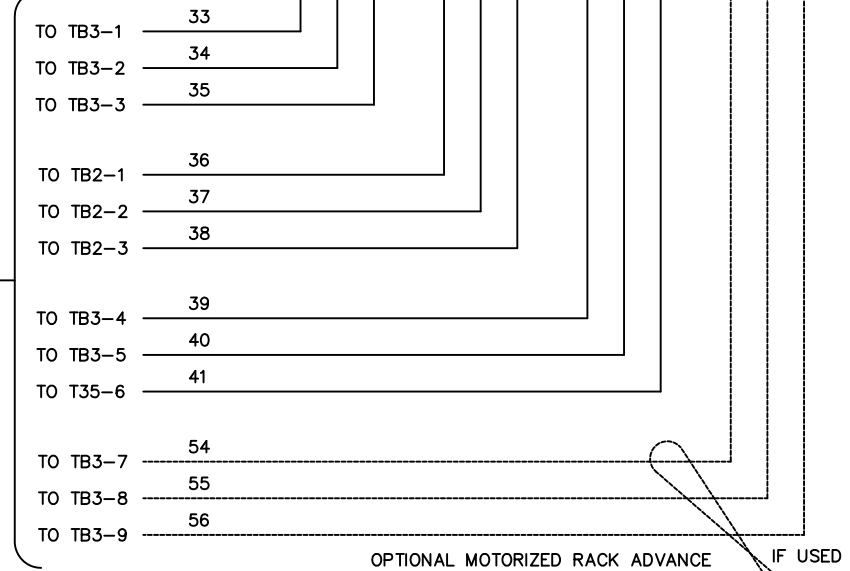

NOTES:

1. MAXIMUM INRUSH CURRENT 2.5 AMPS ON ANY ONE CONDUCTOR. MAXIMUM CONSTANT CURRENT 1 AMP ON ANY ONE CONDUCTOR.
2. MAXIMUM ALLOWABLE CURRENT 1 AMP AT 120V.
3. JUMPER BETWEEN TB2-12 AND TB2-13.
4. JUMPER BETWEEN TB3-23 AND TB3-24.
5. AFTER ASSEMBLY CONNECT WIRE #21 BETWEEN TB2-7 AND TB3-17.

CUSTOMER TO SUPPLY RATED VOLTAGE /PHASE/Hz, AS SPECIFIED PER ORDER TO DISCONNECT SWITCH. ALL POWER SUPPLIED TO EACH CONNECTION POINT MUST COMPLY WITH ALL LOCAL ELECTRIC CODES.			
DR.BY	J.MCALLISTER	SCALE	NONE
DATE	23OCT03	SHEET	1 OF 1

REV.	DESCRIPTION	DATE	BY
A	COMPLETE REVISION TO SHOW TERMINAL BLOCK WIRING CONNECTIONS	23OCT03	JAM

REV.	DESCRIPTION	DATE	BY

Champion
The Dishwashing Machine Specialists

USN-72 STEAM
WIRING INTERCONNECTIONS
REV. A

B 701728

ELECTRIC HEAT MODELS

SUPPLY CONNECTION #2
CUSTOMER SUPPLIED
440/60/3
50A AT 90°C
MIN. WIRE RATING

SUPPLY CONNECTION #1
CUSTOMER SUPPLIED
440/60/3
45A AT 90°C
MIN. WIRE RATING

TB2 AND TB3 LOCATED IN WIREWAYS ON FRONT OF TANKS

MAIN CONTROL CABINET REMOTELY LOCATED

50A AT 90°C
MIN. WIRE RATING
3 - WIRES FOR RINSE TANK HEATER WIRING NUMBERED 63, 64, 65 SEE TERMINAL BLOCK TB-5 DETAIL AT RIGHT.

35A AT 90°C
MIN. WIRE RATING
3 - WIRES FOR WASH TANK HEATER WIRING NUMBERED 60, 61, 62. SEE TERMINAL BLOCK TB-4 DETAIL AT RIGHT.

15A AT 90°C
MIN. WIRE RATING
9 - WIRES FOR MOTOR WIRING NUMBERED 33-41 ADD 3 MOTOR WIRES NUMBERED 54-56 FOR MODELS WITH OPTIONAL MRA TABLE. SEE TERMINAL BLOCK TB-2 AND TB-3 DETAIL AT RIGHT.

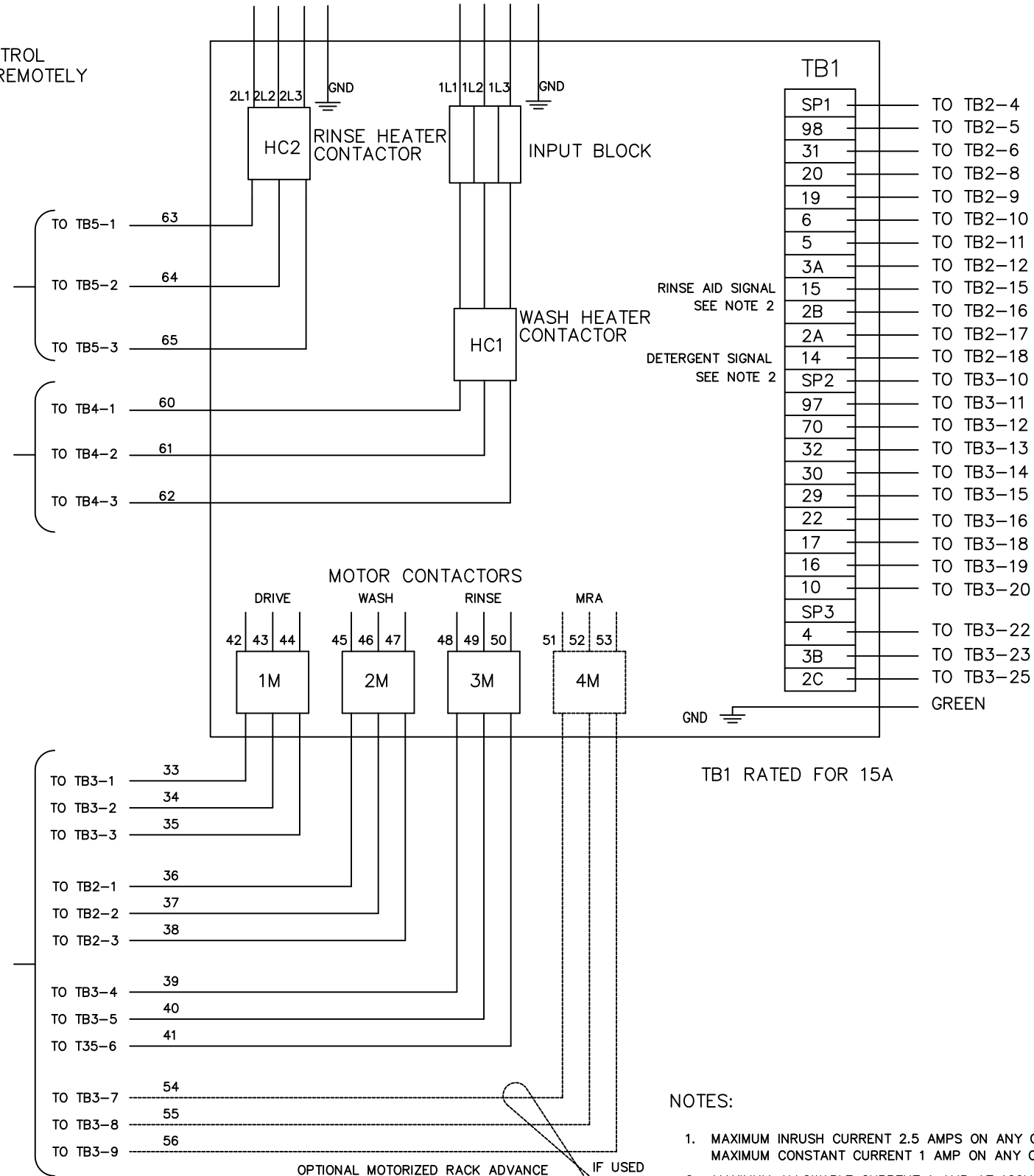

TB1 RATED FOR 15A

NOTES:

1. MAXIMUM INRUSH CURRENT 2.5 AMPS ON ANY ONE CONDUCTOR. MAXIMUM CONSTANT CURRENT 1 AMP ON ANY ONE CONDUCTOR.
2. MAXIMUM ALLOWABLE CURRENT 1 AMP AT 120V.
3. JUMPER BETWEEN TB2-12 AND TB2-13.
4. JUMPER BETWEEN TB3-23 AND TB3-24.
5. AFTER ASSEMBLY CONNECT WIRE #21 BETWEEN TB2-7 AND TB3-17.

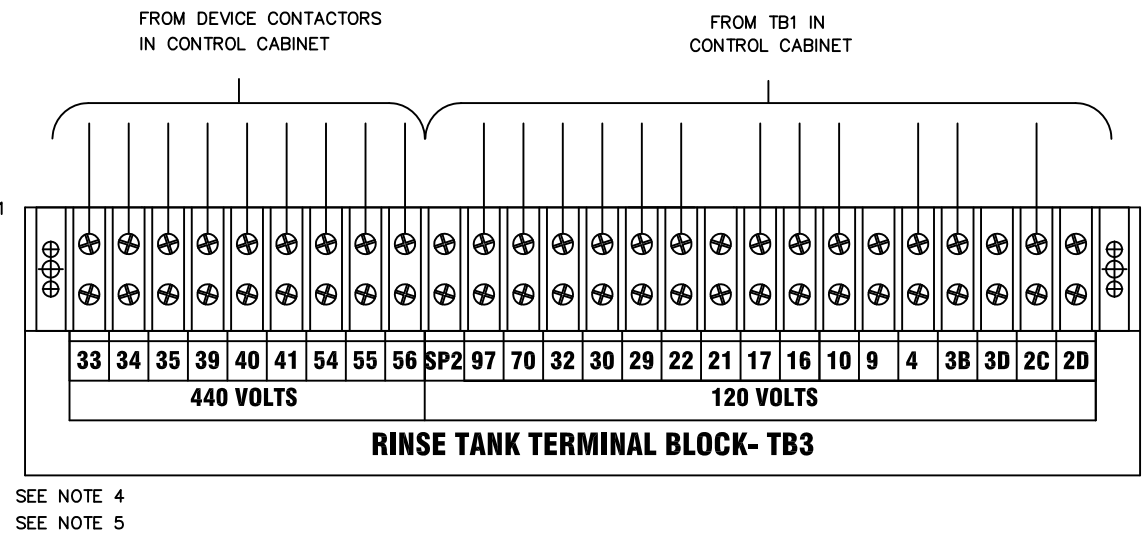
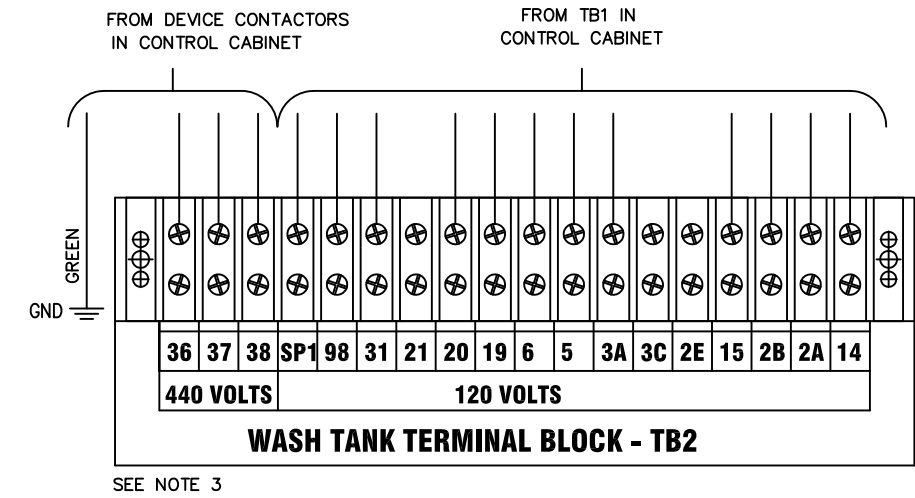

TB4 AND TB5 LOCATED IN JUNCTION BOXES FOR TANK HEATERS

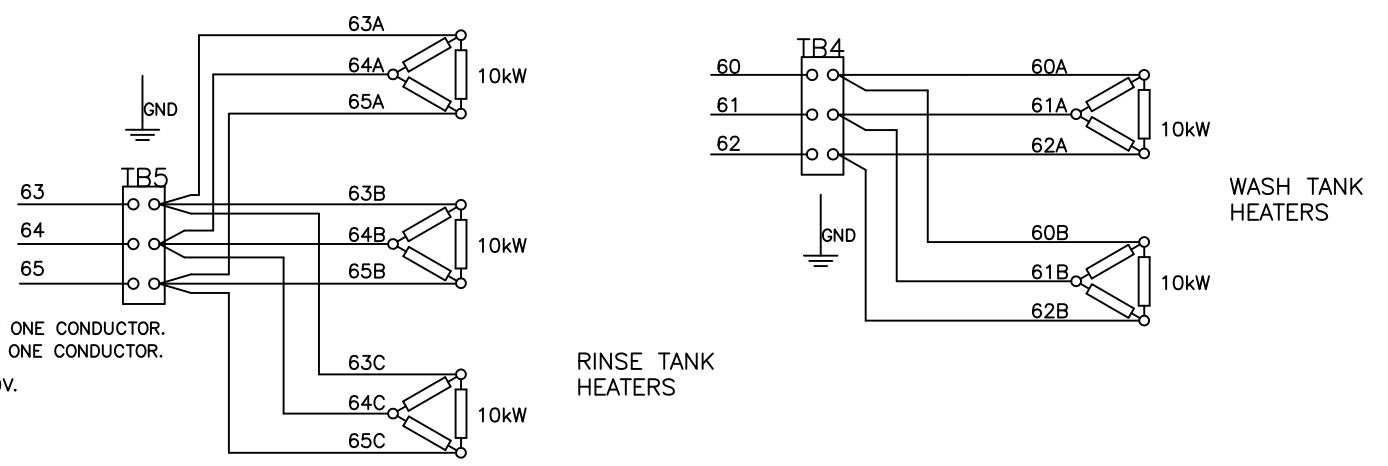

CUSTOMER TO SUPPLY RATED VOLTAGE /PHASE/Hz, AS SPECIFIED PER ORDER, TO DISCONNECT SWITCH. ALL POWER SUPPLIED TO EACH CONNECTION POINT MUST COMPLY WITH ALL LOCAL ELECTRIC CODES.			
DR. BY	J.MCALLISTER	SCALE	NONE
DATE	7OCT03	SHEET	1 OF 1

REV.	DESCRIPTION	DATE	BY
A	REMOVE THRD ELEC CONNECTION. ADD NOTE & TB2 / TB3 DETAIL. RESIZE FOR BETTER CLARITY	9 SEPT 03	MJM
B	COMPLETE REVISION TO SHOW TERMINAL BLOCK WIRING CONNECTIONS	7OCT03	JAM

REV.	DESCRIPTION	DATE	BY

Champion
The Dishwashing Machine Specialists

USN-72 ELECTRIC WIRING INTERCONNECTIONS
B 701729 REV. B

NOTE: THIS DRAWING FOR DETERMINATION OF WIRE SIZE AND QUANTITY OF WIRES FOR INTERCONNECTION PURPOSES ONLY. NOT INTENDED TO BE AN ACCURATE DEPICTION OF COMPONENT POSITION IN CONTROL CABINET.

ALL MOTOR AND HEATER WIRES FROM THE DISHMACHINE WILL WIRE DIRECTLY TO THE CONTROLLING CONTACTOR FOR THAT DEVICE.

ELECTRICAL SUPPLY CONNECTION #1 WILL WIRE TO THE INPUT POWER TERMINAL BLOCK.

50 AMP ELECTRICAL SERVICE FOR CONNECTION # 2 WILL WIRE DIRECTLY TO THE INPUT SIDE OF CONTACTOR.

WIRES LABELED "SP1" AND "SP2" ARE SPARE WIRES AND ARE INTENDED TO TERMINATE AT THE TERMINAL STRIP.

ELECTRIC HEAT MODELS

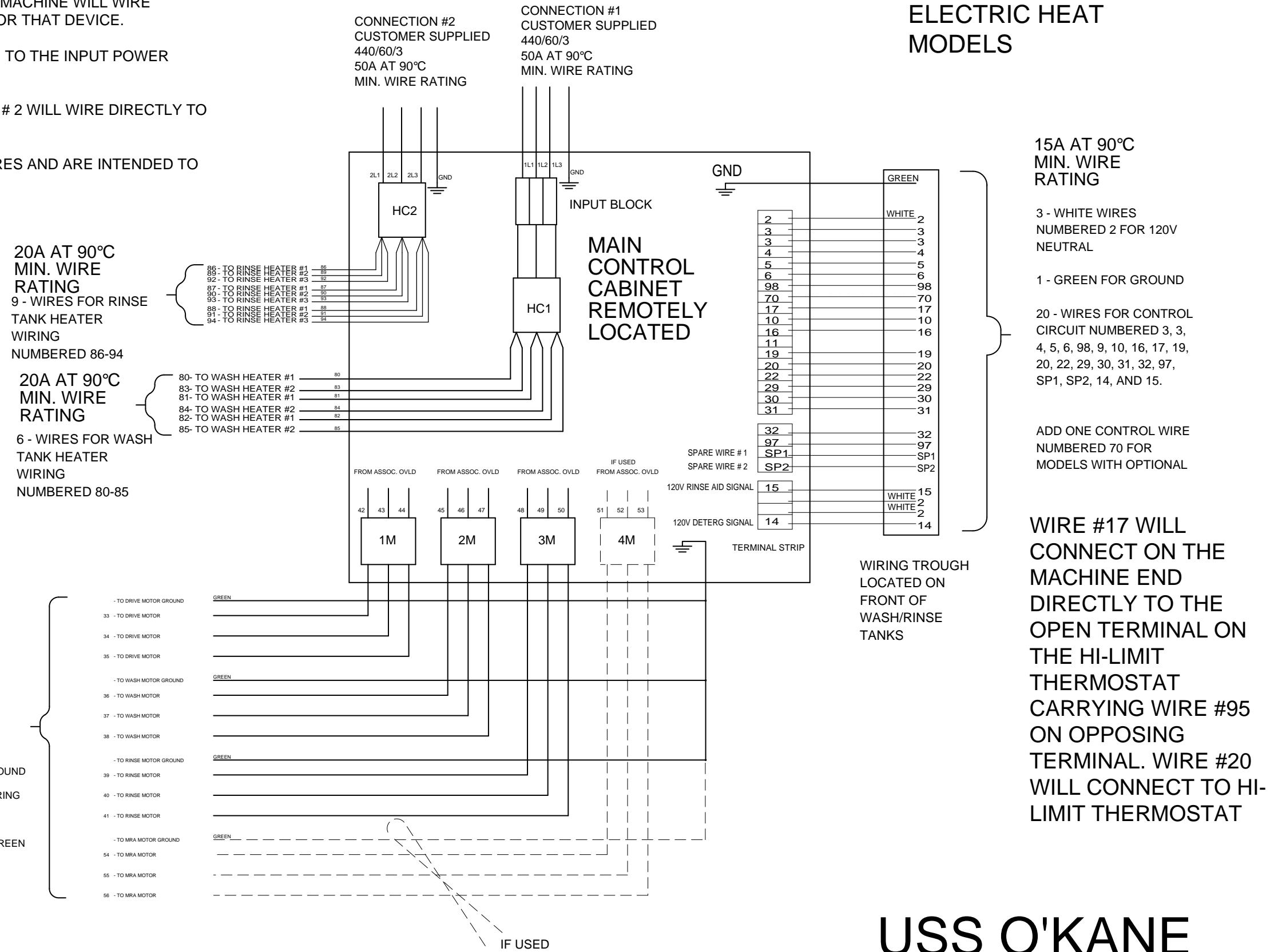

USS O'KANE

CUSTOMER TO SUPPLY RATED VOLTAGE/PHASE/Hz, AS SPECIFIED PER ORDER TO DISCONNECT SWITCH. ALL POWER SUPPLIED TO EACH CONNECTION POINT MUST COMPLY WITH ALL LOCAL ELECTRIC CODES.			
DR. BY	J. NEWTON	SCALE	NONE
DATE	5MAR01	SHEET	1 OF 1

REV.	DESCRIPTION	DATE	BY

REV.	DESCRIPTION	DATE	BY

Champion
The Dishwashing Machine Specialists

USN-72 ELECTRIC WIRING INTERCONNECTIONS		
B	B701729 - 1	REV.

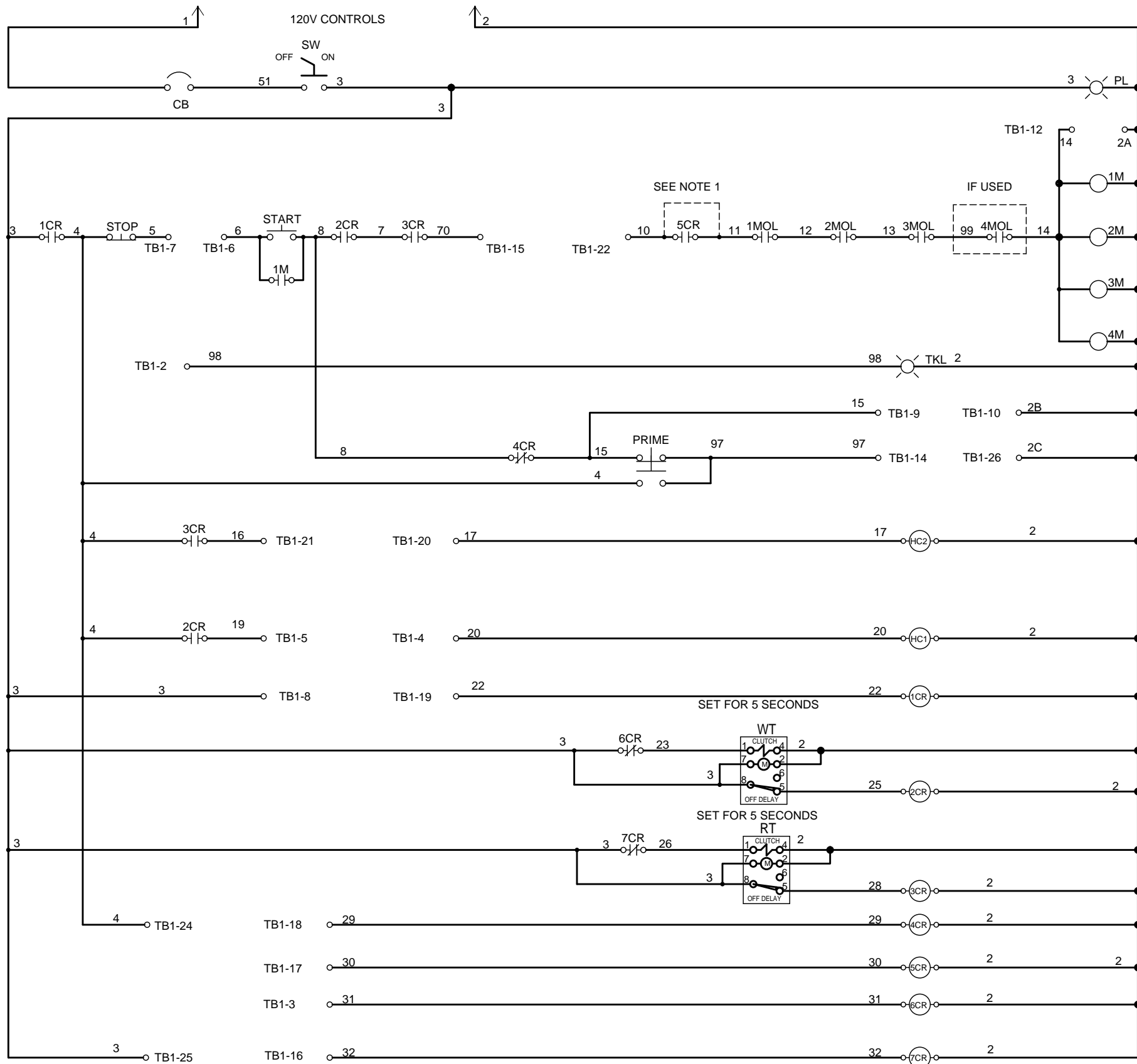

TO CUSTOMER DISCONNECT SWITCH FUSED FOR 45A MAX. AT 440/60/3.

!!!!!! WARNING !!!!
MULTIPLE POWER SOURCES ARE PRESENT IN THIS CABINET. DISCONNECT ALL POWER SOURCES PRIOR TO SERVICING.

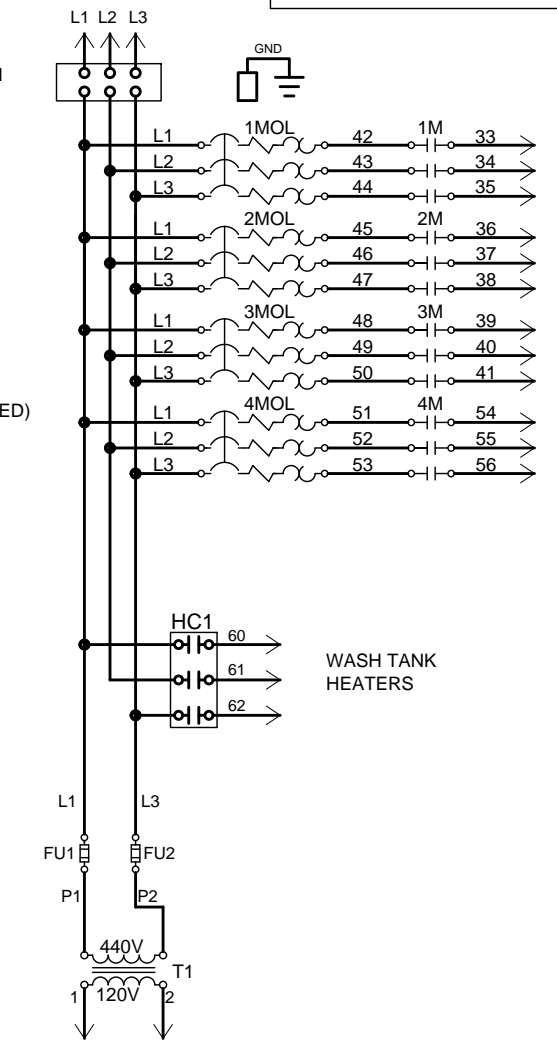

TO CUSTOMER DISCONNECT SWITCH FUSED FOR 50A MAX. AT 440/60/3.

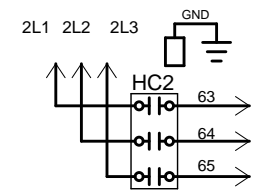

PARTS LOCATED IN CONTROL PANEL	
1CR	DOOR SAFETY SWITCH HOLD-IN RELAY
2CR	WASH TANK FLOAT HOLD-IN RELAY
3CR	RINSE TANK FLOAT HOLD-IN RELAY
4CR	FINAL RINSE SWITCH RELAY
5CR	TABLE LIMIT SWITCH RELAY
6CR	WASH TANK FLOAT SWITCH RELAY
7CR	RINSE TANK SWITCH RELAY
1M	DRIVE CONTACTOR
1MOL	DRIVE MOTOR OVERLOAD
2M	WASH CONTACTOR
2MOL	WASH MOTOR OVERLOAD
3M	RINSE CONTACTOR
3MOL	RINSE MOTOR OVERLOAD
4M	MRA CONTACTOR
4MOL	MRA MOTOR OVERLOAD
BC1	BOOSTER HEATER CONTACTOR
CB	CIRCUIT BREAKER
DSS	DOOR SAFETY SWITCH
FRSW	FINAL RINSE SWITCH
FRV	FINAL RINSE FILL VALVE
FU	FUSE-TRANSFORMER
HC1	WASH TANK HEAT CONTACTOR
HC2	RINSE TANK HEAT CONTACTOR
HLRT	HIGH LIMIT RINSE TANK
HLWT	HIGH LIMIT WASH TANK
MSW	MOTOR STOP SWITCH
MRA	MACHINE RACK ADVANCE LIMIT SWITCH
PL	POWER ON LIGHT
RFSW	RINSE TANK FLOAT SWITCH
R	RINSE TANK DOOR SAFETY SWITCH
RT	RINSE TANK FLOAT TIMER
SW	POWER SWITCH
T1	440V:120V TRANSFORMER
TB6	WASH HEATER TERMINAL BLOCK
TB7	RINSE HEATER TERMINAL BLOCK
TKL	LOW TEMP INDICATOR LIGHT
TLS	TABLE LIMIT SWITCH
TSB	BOOSTER THERMOSTAT
TSK	LOW TEMPERATURE CUT-OFF THERMOSTAT
TSR	RINSE TANK THERMOSTAT
TSW	WASH TANK THERMOSTAT
W	WASH TANK DOOR SAFETY SWITCH
WFSW	WASH TANK FLOAT SWITCH
WT	WASH TANK FLOAT TIMER

NOTES
1. REMOVE JUMPER ACROSS N.O. 5CR CONTACT WHEN TABLE LIMIT SWITCH IS USED.

!!!!!! WARNING !!!!
MULTIPLE POWER SOURCES ARE PRESENT IN THIS CABINET. DISCONNECT ALL POWER SOURCES PRIOR TO SERVICING.

DIAGRAM STATE
POWER OFF
DOORS CLOSED
TANKS EMPTY
END OF CYCLE

CUSTOMER TO SUPPLY RATED VOLTAGE/PHASE/HZ, AS SPECIFIED PER ORDER TO DISCONNECT SWITCH. ALL POWER SUPPLIED TO EACH CONNECTION POINT MUST COMPLY WITH ALL LOCAL ELECTRIC CODES.			
DR. BY	J.MCALLISTER	SCALE	
DATE	16OCT03	SHEET	1 OF 1

REV.	DESCRIPTION	DATE	BY

REV.	DESCRIPTION	DATE	BY

Champion
The Dishwashing Machine Specialists

USN-72, ELECTRIC PANEL WIRING DIAGRAM
B **701829** REV.

!!!!!! WARNING !!!!!
 MULTIPLE POWER SOURCES ARE PRESENT
 IN THIS CABINET. DISCONNECT ALL POWER
 SOURCES PRIOR TO SERVICING.

* PARTS LOCATED IN CONTROL PANEL

1CR	* DOOR SAFETY SWITCH HOLD-IN RELAY
2CR	* WASH TANK FLOAT HOLD-IN RELAY
3CR	* RINSE TANK FLOAT HOLD-IN RELAY
4CR	* FINAL RINSE SWITCH RELAY
5CR	* TABLE LIMIT SWITCH RELAY
6CR	* WASH TANK FLOAT SWITCH RELAY
7CR	* RINSE TANK FLOAT SWITCH RELAY
1M	* DRIVE CONTACTOR
1MOL	* DRIVE MOTOR OVERLOAD
2M	* WASH CONTACTOR
2MOL	* WASH MOTOR OVERLOAD
3M	* RINSE CONTACTOR
3MOL	* RINSE MOTOR OVERLOAD
4M	* MRA CONTACTOR
4MOL	* MRA MOTOR OVERLOAD
BC1	* BOOSTER HEATER CONTACTOR
CB	* CIRCUIT BREAKER
DSS	* DOOR SAFETY SWITCH
FRSW	* FINAL RINSE SWITCH
FRV	* FINAL RINSE FILL VALVE
FU-	* FUSE-TRANSFORMER
HC1	* WASH TANK HEAT CONTACTOR
HC2	* RINSE TANK HEAT CONTACTOR
HLRT	* HIGH LIMIT RINSE TANK
HLWT	* HIGH LIMIT WASH TANK
MSW	* MOTOR STOP SWITCH
MRA	* MACHINE RACK ADVANCE LIMIT SWITCH
PL	* POWER ON LIGHT
RFSW	* RINSE TANK FLOAT SWITCH
R	* RINSE TANK DOOR SAFETY SWITCH
RT	* RINSE TANK FLOAT TIMER
SW	* POWER SWITCH
T1	* 440V:120V TRANSFORMER
TB6	* WASH HEATER TERMINAL BLOCK
TB7	* RINSE HEATER TERMINAL BLOCK
TKL	* LOW TEMP INDICATOR LIGHT
TLS	* TABLE LIMIT SWITCH
TSB	* BOOSTER THERMOSTAT
TSK	* LOW TEMPERATURE CUT-OFF THERMOSTAT
TSR	* RINSE TANK THERMOSTAT
TSW	* WASH TANK THERMOSTAT
W	* WASH TANK DOOR SAFETY SWITCH
WFSW	* WASH TANK FLOAT SWITCH
WT	* WASH TANK FLOAT TIMER

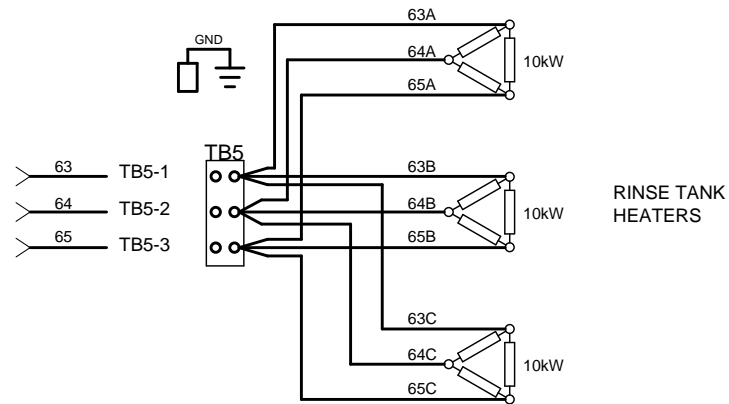
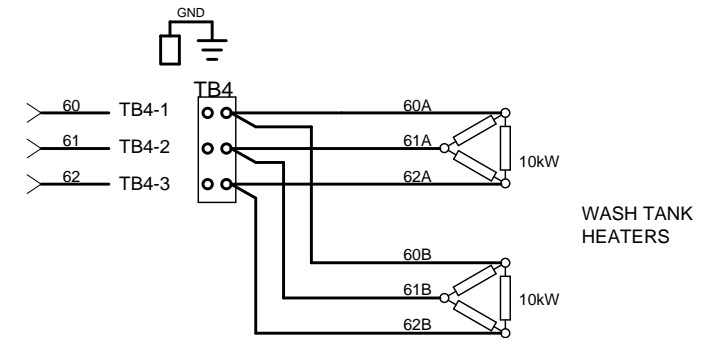
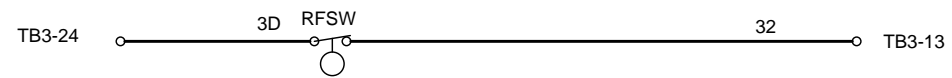
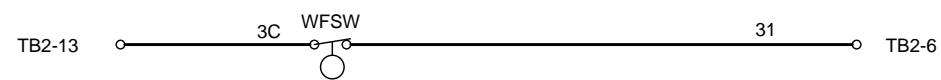
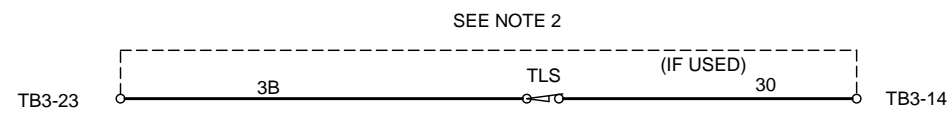
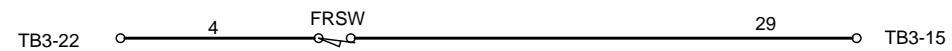
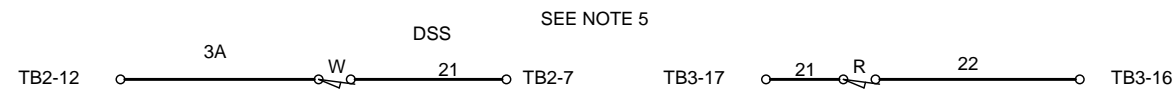
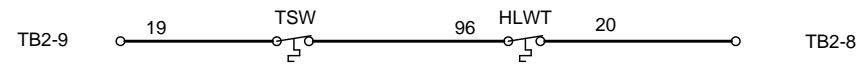
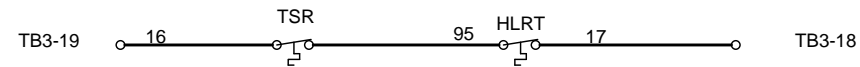
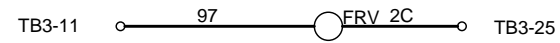
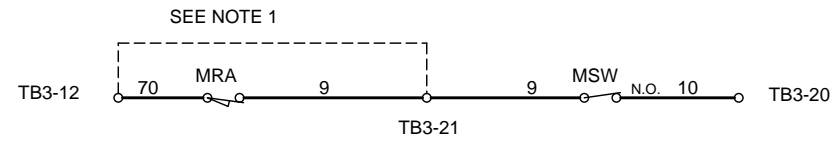
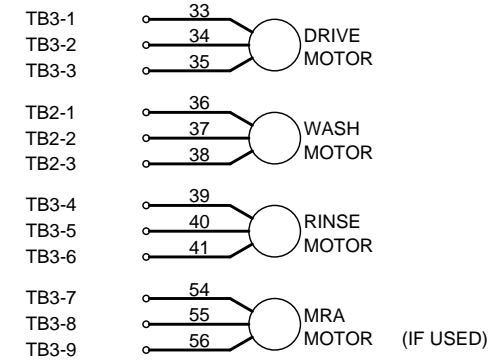
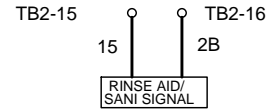
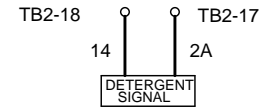
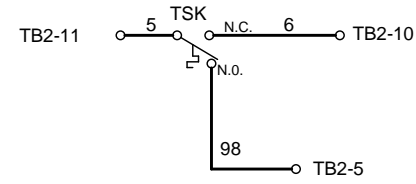

NOTES

1. REMOVE JUMPER ACROSS WIRES 70 AND 9 WHEN RACK ADVANCE TABLE IS USED.
2. REMOVE JUMPER BETWEEN TB3-23 AND TB3-14 WHEN TABLE LIMIT SWITCH IS USED.
3. INSTALL JUMPERS BETWEEN TB3-23 AND TB3-24.
4. INSTALL JUMPER BETWEEN TB2-12 AND TB2-13.
5. AFTER ASSEMBLY INSTALL WIRE #21 BETWEEN TB2-7 AND TB3-17.

DIAGRAM STATE
 POWER OFF
 DOORS CLOSED
 TANKS EMPTY
 END OF CYCLE

CUSTOMER TO SUPPLY RATED VOLTAGE/PHASE/Hz, AS SPECIFIED PER ORDER. TO DISCONNECT SWITCH. ALL POWER SUPPLIED TO EACH CONNECTION POINT MUST COMPLY WITH ALL LOCAL ELECTRIC CODES.			
DR. BY	J.MCALLISTER	SCALE	
DATE	23OCT03	SHEET	1 OF 1

REV.	DESCRIPTION	DATE	BY

REV.	DESCRIPTION	DATE	BY

Champion The Dishwashing Machine Specialists	USN-72, ELECTRIC MACHINE WIRING DIAGRAM	
	B 701830	REV.

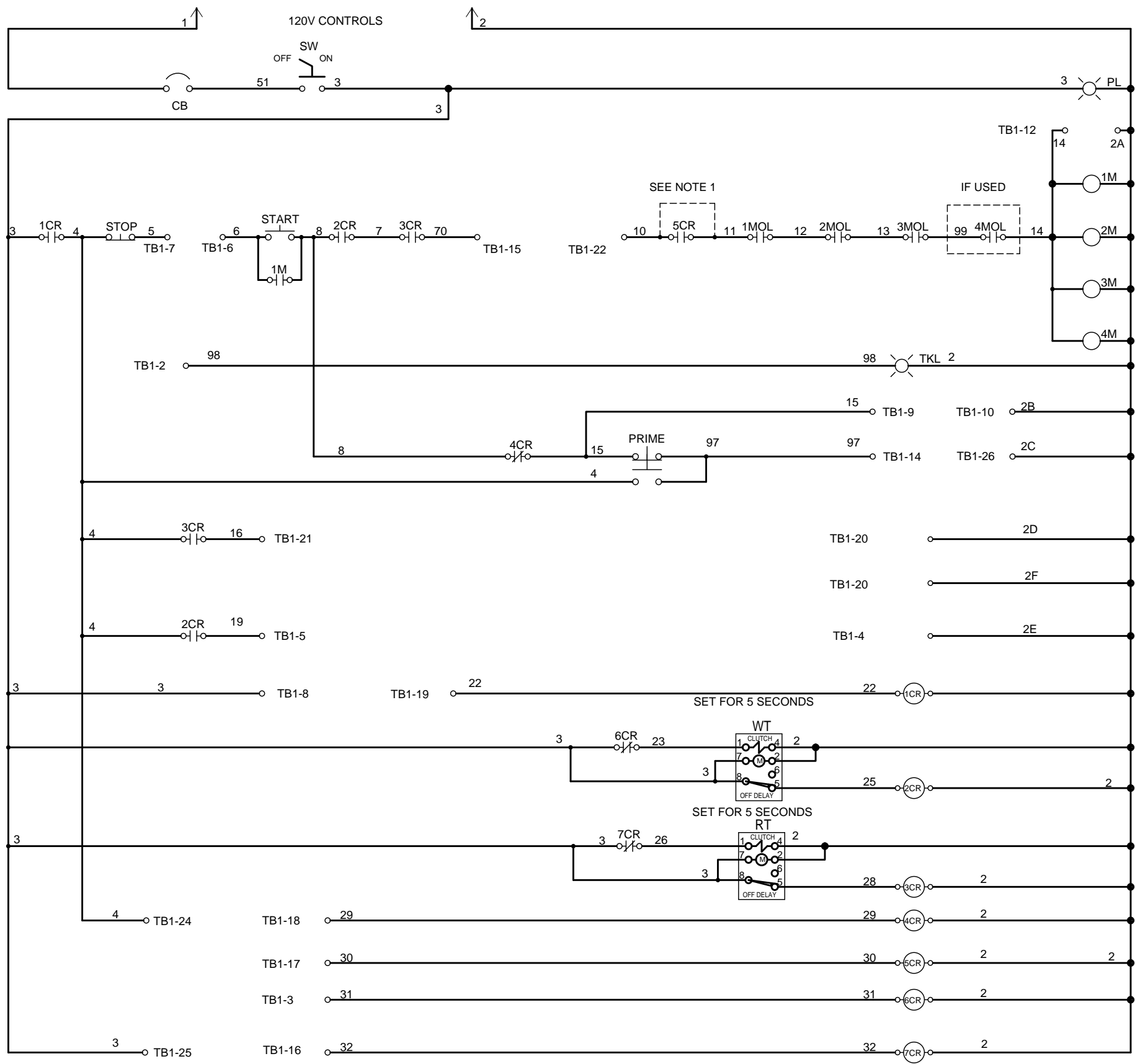

TO CUSTOMER
DISCONNECT SWITCH
FUSED FOR 15A MAX. AT
440/60/3.

!!!!!! WARNING !!!!
MULTIPLE POWER SOURCES ARE PRESENT
IN THIS CABINET. DISCONNECT ALL POWER
SOURCES PRIOR TO SERVICING.

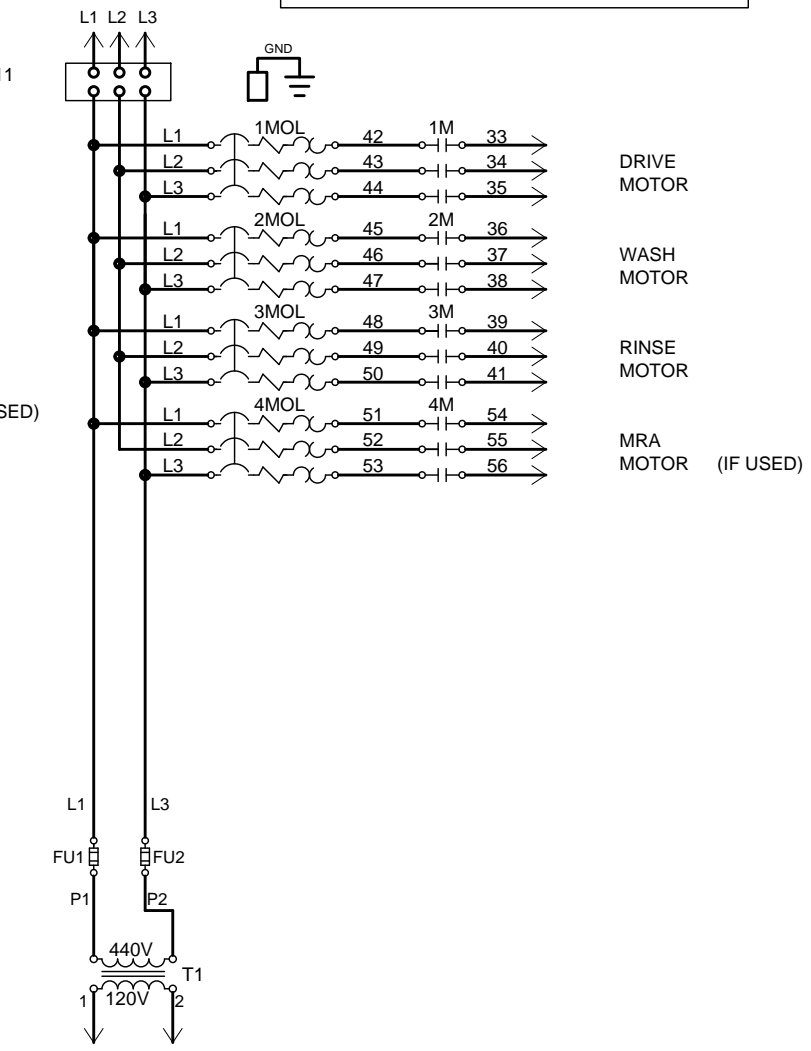

* PARTS LOCATED IN CONTROL PANEL

1CR	DOOR SAFETY SWITCH HOLD-IN RELAY
2CR	WASH TANK FLOAT HOLD-IN RELAY
3CR	RINSE TANK FLOAT HOLD-IN RELAY
4CR	FINAL RINSE SWITCH RELAY
5CR	TABLE LIMIT SWITCH RELAY
6CR	WASH TANK FLOAT SWITCH RELAY
7CR	RINSE TANK FLOAT SWITCH RELAY
1M	DRIVE CONTACTOR
1MOL	DRIVE MOTOR OVERLOAD
2M	WASH CONTACTOR
2MOL	WASH MOTOR OVERLOAD
3M	RINSE CONTACTOR
3MOL	RINSE MOTOR OVERLOAD
4M	MRA CONTACTOR
4MOL	MRA MOTOR OVERLOAD
BC1	BOOSTER HEATER CONTACTOR
CB	CIRCUIT BREAKER
DSS	DOOR SAFETY SWITCH
FRSW	FINAL RINSE SWITCH
FRV	FINAL RINSE FILL VALVE
FU-	FUSE-TRANSFORMER
HC1	WASH TANK HEAT CONTACTOR
HC2	RINSE TANK HEAT CONTACTOR
HLRT	HIGH LIMIT RINSE TANK
HLWT	HIGH LIMIT WASH TANK
MSW	MOTOR STOP SWITCH
MRA	MACHINE RACK ADVANCE LIMIT SWITCH
PL	POWER ON LIGHT
RFSW	RINSE TANK FLOAT SWITCH
R	RINSE TANK DOOR SAFETY SWITCH
RT	RINSE TANK FLOAT TIMER
SW	POWER SWITCH
T1	440V-120V TRANSFORMER
TB6	WASH HEATER TERMINAL BLOCK
TB7	RINSE HEATER TERMINAL BLOCK
TKL	LOW TEMP INDICATOR LIGHT
TLS	TABLE LIMIT SWITCH
TSB	BOOSTER THERMOSTAT
TSK	LOW TEMPERATURE CUT-OFF THERMOSTAT
TSR	RINSE TANK THERMOSTAT
TSW	WASH TANK THERMOSTAT
W	WASH TANK DOOR SAFETY SWITCH
WFSW	WASH TANK FLOAT SWITCH
WT	WASH TANK FLOAT TIMER

NOTES
1. REMOVE JUMPER ACROSS N.O. 5CR CONTACT WHEN TABLE LIMIT SWITCH IS USED.

!!!!!! WARNING !!!!
MULTIPLE POWER SOURCES ARE PRESENT
IN THIS CABINET. DISCONNECT ALL POWER
SOURCES PRIOR TO SERVICING.

DIAGRAM STATE
POWER OFF
DOORS CLOSED
TANKS EMPTY
END OF CYCLE

CUSTOMER TO SUPPLY RATED VOLTAGE/PHASE/Hz, AS SPECIFIED PER ORDER. TO DISCONNECT SWITCH. ALL POWER SUPPLIED TO EACH CONNECTION POINT MUST COMPLY WITH ALL LOCAL ELECTRIC CODES.			
DR.BY	J.MCALLISTER	SCALE	
DATE	23OCT03	SHEET	1 OF 1

REV.	DESCRIPTION	DATE	BY

REV.	DESCRIPTION	DATE	BY

Champion The Dishwashing Machine Specialists	USN-72, STEAM PANEL WIRING DIAGRAM	
	B 701832	REV.

!!!!!! WARNING !!!!!
 MULTIPLE POWER SOURCES ARE PRESENT
 IN THIS CABINET. DISCONNECT ALL POWER
 SOURCES PRIOR TO SERVICING.

* PARTS LOCATED IN CONTROL PANEL

1CR	DOOR SAFETY SWITCH HOLD-IN RELAY
2CR	WASH TANK FLOAT HOLD-IN RELAY
3CR	RINSE TANK FLOAT HOLD-IN RELAY
4CR	FINAL RINSE SWITCH RELAY
5CR	TABLE LIMIT SWITCH RELAY
6CR	WASH TANK FLOAT SWITCH RELAY
7CR	RINSE TANK FLOAT SWITCH RELAY
1M	DRIVE CONTACTOR
1MOL	DRIVE MOTOR OVERLOAD
2M	WASH CONTACTOR
2MOL	WASH MOTOR OVERLOAD
3M	RINSE CONTACTOR
3MOL	RINSE MOTOR OVERLOAD
4M	MRA CONTACTOR
4MOL	MRA MOTOR OVERLOAD
BC1	BOOSTER HEATER CONTACTOR
CB	CIRCUIT BREAKER
DSS	DOOR SAFETY SWITCH
FRSW	FINAL RINSE SWITCH
FRV	FINAL RINSE FILL VALVE
FU	FUSE-TRANSFORMER
HC1	WASH TANK HEAT CONTACTOR
HC2	RINSE TANK HEAT CONTACTOR
HLRT	HIGH LIMIT RINSE TANK
HLWT	HIGH LIMIT WASH TANK
MSW	MOTOR STOP SWITCH
MRA	MACHINE RACK ADVANCE LIMIT SWITCH
PL	POWER ON LIGHT
RFSW	RINSE TANK FLOAT SWITCH
R	RINSE TANK DOOR SAFETY SWITCH
RT	RINSE TANK FLOAT TIMER
SW	POWER SWITCH
T1	440V:120V TRANSFORMER
TB6	WASH HEATER TERMINAL BLOCK
TB7	RINSE HEATER TERMINAL BLOCK
TKL	LOW TEMP INDICATOR LIGHT
TLS	TABLE LIMIT SWITCH
TSB	BOOSTER THERMOSTAT
TSK	LOW TEMPERATURE CUT-OFF THERMOSTAT
TSR	RINSE TANK THERMOSTAT
TSW	WASH TANK THERMOSTAT
W	WASH TANK DOOR SAFETY SWITCH
WFSW	WASH TANK FLOAT SWITCH
WT	WASH TANK FLOAT TIMER

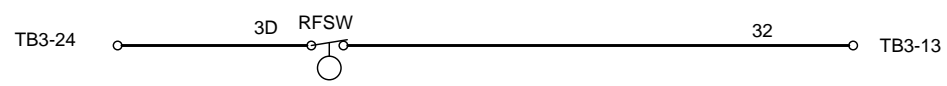
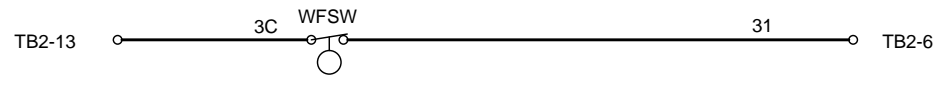
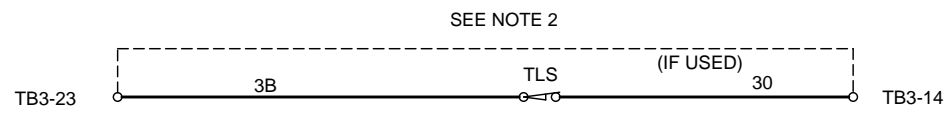
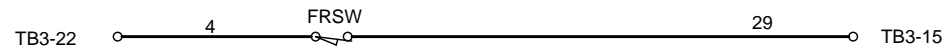
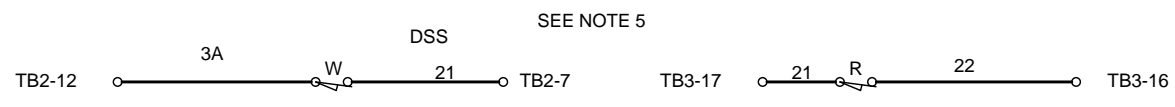
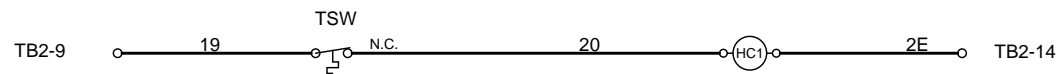
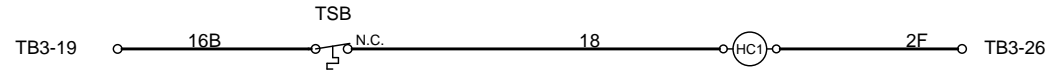
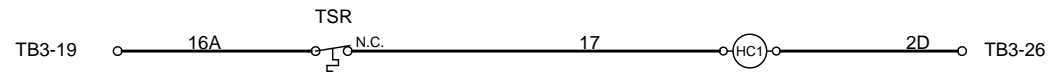
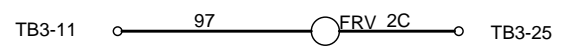
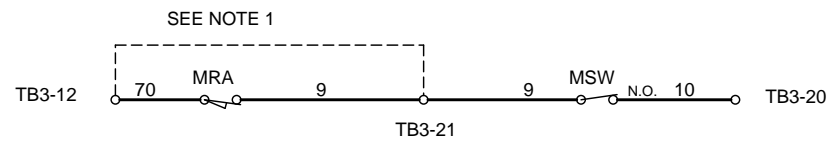
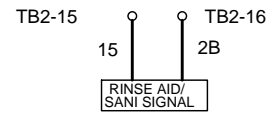
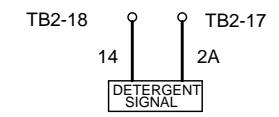
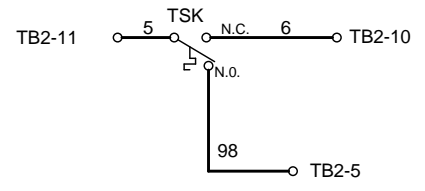
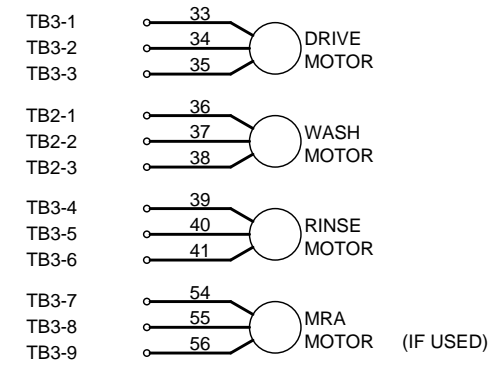

- NOTES
- REMOVE JUMPER ACROSS WIRES 70 AND 9 WHEN RACK ADVANCE TABLE IS USED.
 - REMOVE JUMPER BETWEEN TB3-23 AND TB3-14 WHEN TABLE LIMIT SWITCH IS USED.
 - INSTALL JUMPERS BETWEEN TB3-23 AND TB3-24.
 - INSTALL JUMPER BETWEEN TB2-12 AND TB2-13.
 - AFTER ASSEMBLY INSTALL WIRE #21 BETWEEN TB2-7 AND TB3-17.

DIAGRAM STATE
 POWER OFF
 DOORS CLOSED
 TANKS EMPTY
 END OF CYCLE

CUSTOMER TO SUPPLY RATED VOLTAGE/PHASE/Hz, AS SPECIFIED PER ORDER, TO DISCONNECT SWITCH. ALL POWER SUPPLIED TO EACH CONNECTION POINT MUST COMPLY WITH ALL LOCAL ELECTRIC CODES.			
DR. BY	J.MCALLISTER	SCALE	
DATE	23OCT03	SHEET	1 OF 1

REV.	DESCRIPTION	DATE	BY

REV.	DESCRIPTION	DATE	BY

Champion The Dishwashing Machine Specialists	USN-72, STEAM MACHINE WIRING DIAGRAM	
	B 701833	REV.

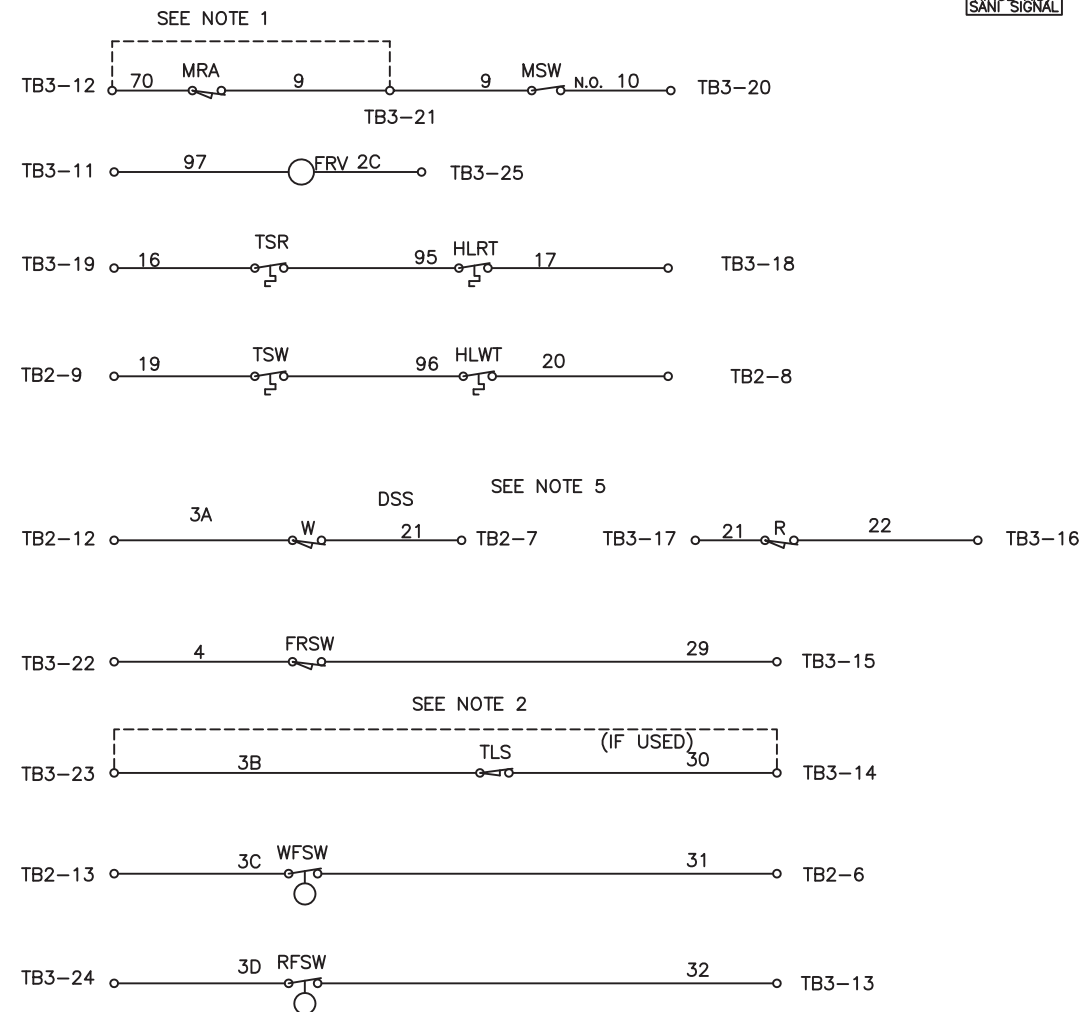
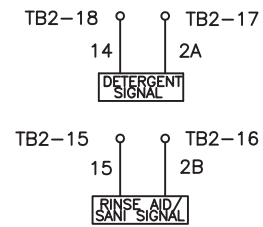
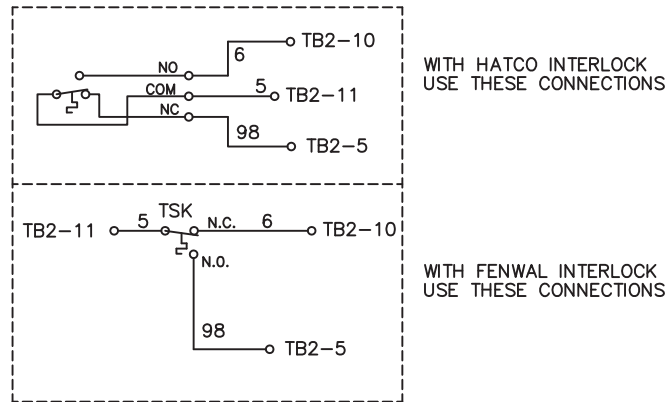

!!!!!! WARNING !!!!!
MULTIPLE POWER SOURCES ARE PRESENT
IN THIS CABINET. DISCONNECT ALL POWER
SOURCES PRIOR TO SERVICING.

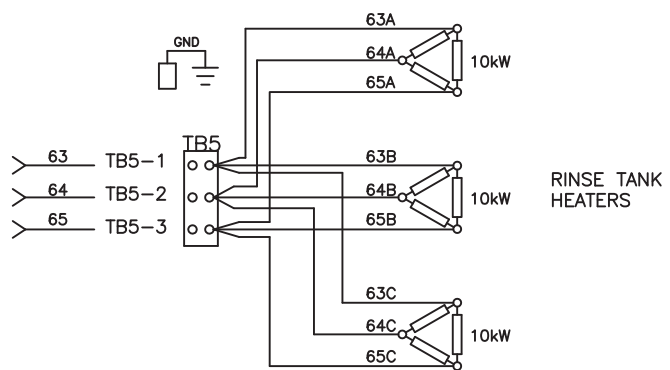
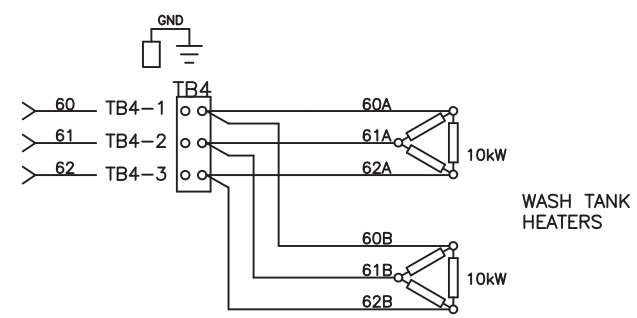
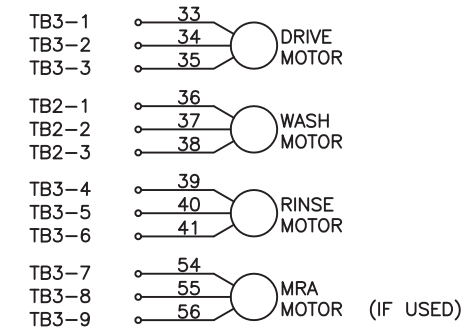

* PARTS LOCATED IN CONTROL PANEL

1CR	* DOOR SAFETY SWITCH HOLD-IN RELAY
2CR	* WASH TANK FLOAT HOLD-IN RELAY
3CR	* RINSE TANK FLOAT HOLD-IN RELAY
4CR	* FINAL RINSE SWITCH RELAY
5CR	* TABLE LIMIT SWITCH RELAY
6CR	* WASH TANK FLOAT SWITCH RELAY
7CR	* RINSE TANK FLOAT SWITCH RELAY
1M	* DRIVE CONTACTOR
1MOL	* DRIVE MOTOR OVERLOAD
2M	* WASH CONTACTOR
2MOL	* WASH MOTOR OVERLOAD
3M	* RINSE CONTACTOR
3MOL	* RINSE MOTOR OVERLOAD
4M	* MRA CONTACTOR
4MOL	* MRA MOTOR OVERLOAD
BC1	* BOOSTER HEATER CONTACTOR
CB	* CIRCUIT BREAKER
DSS	* DOOR SAFETY SWITCH
FRSW	* FINAL RINSE SWITCH
FRV	* FINAL RINSE FILL VALVE
FU-	* FUSE-TRANSFORMER
HC1	* WASH TANK HEAT CONTACTOR
HC2	* RINSE TANK HEAT CONTACTOR
HLRT	* HIGH LIMIT RINSE TANK
HLWT	* HIGH LIMIT WASH TANK
MSW	* MOTOR STOP SWITCH
MRA	* MACHINE RACK ADVANCE LIMIT SWITCH
PL	* POWER ON LIGHT
RFSW	* RINSE TANK FLOAT SWITCH
R	* RINSE TANK DOOR SAFETY SWITCH
RT	* RINSE TANK FLOAT TIMER
SW	* POWER SWITCH
T1	* 440V:120V TRANSFORMER
TB6	* WASH HEATER TERMINAL BLOCK
TB7	* RINSE HEATER TERMINAL BLOCK
TKL	* LOW TEMP INDICATOR LIGHT
TLS	* TABLE LIMIT SWITCH
TSB	* BOOSTER THERMOSTAT
TSK	* LOW TEMPERATURE CUT-OFF THERMOSTAT
TSR	* RINSE TANK THERMOSTAT
TSW	* WASH TANK THERMOSTAT
W	* WASH TANK DOOR SAFETY SWITCH
WFSW	* WASH TANK FLOAT SWITCH
WT	* WASH TANK FLOAT TIMER

- NOTES
1. REMOVE JUMPER ACROSS WIRES 70 AND 9 WHEN RACK ADVANCE TABLE IS USED.
 2. REMOVE JUMPER BETWEEN TB3-23 AND TB3-14 WHEN TABLE LIMIT SWITCH IS USED.
 3. INSTALL JUMPERS BETWEEN TB3-23 AND TB3-24.
 4. INSTALL JUMPER BETWEEN TB2-12 AND TB2-13.
 5. AFTER ASSEMBLY INSTALL WIRE #21 BETWEEN TB2-7 AND TB3-17.

DIAGRAM STATE
POWER OFF
DOORS CLOSED
TANKS EMPTY
END OF CYCLE

C-57 Modified Booster Assembly
Beginning with S/N J08122570 and Above

CUSTOMER TO SUPPLY RATED VOLTAGE/PHASE/Hz, AS SPECIFIED PER ORDER TO DISCONNECT SWITCH. ALL POWER SUPPLIED TO EACH CONNECTION POINT MUST COMPLY WITH ALL LOCAL ELECTRIC CODES.

DR. BY	J.MCALLISTER	SCALE	
DATE	23OCT03	SHEET	1 OF 1

REV.	DESCRIPTION	DATE	BY
A	ADDED CONNECTIONS FOR HATCO BOOSTER HIGH LIMIT	05JAN09	JAM

REV.	DESCRIPTION	DATE	BY

Champion
The Dishwashing Machine Specialists

USN-72, ELECTRIC MACHINE WIRING DIAGRAM

B	701830	REV. A
---	--------	--------

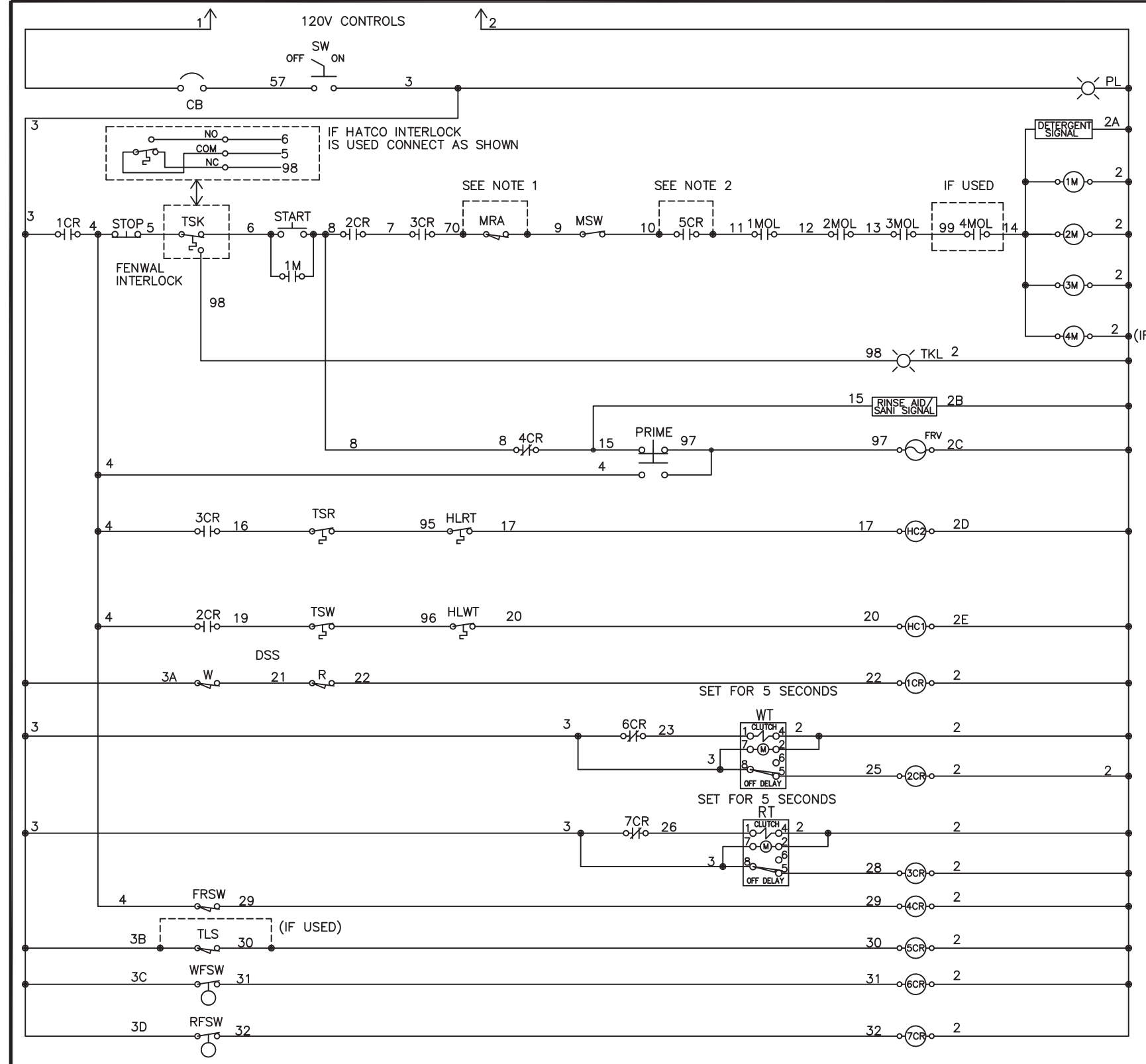

TO CUSTOMER DISCONNECT SWITCH FUSED FOR 50A MAX. AT 440/60/3.

!!!!!! WARNING !!!!!
MULTIPLE POWER SOURCES ARE PRESENT IN THIS CABINET. DISCONNECT ALL POWER SOURCES PRIOR TO SERVICING.

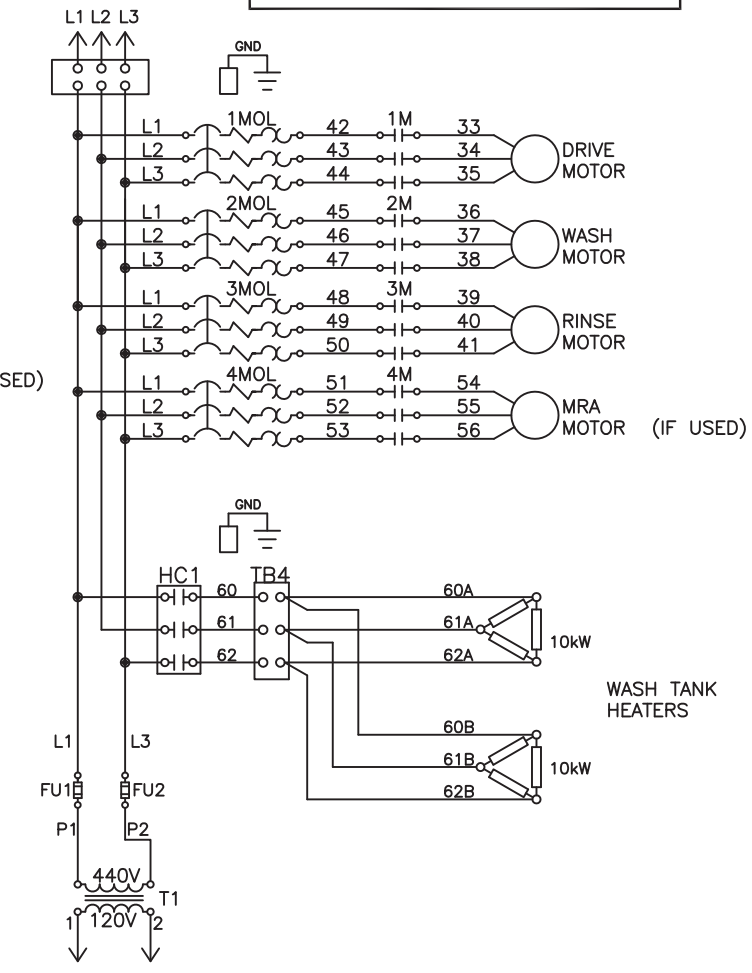

!!!!!! WARNING !!!!!
MULTIPLE POWER SOURCES ARE PRESENT IN THIS CABINET. DISCONNECT ALL POWER SOURCES PRIOR TO SERVICING.

TO CUSTOMER DISCONNECT SWITCH FUSED FOR 50A MAX. AT 440/60/3.

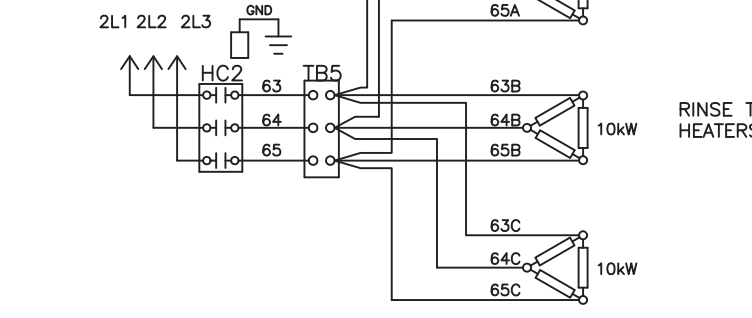

* PARTS LOCATED IN CONTROL PANEL

1CR	* DOOR SAFETY SWITCH HOLD-IN RELAY
2CR	* WASH TANK FLOAT HOLD-IN RELAY
3CR	* RINSE TANK FLOAT HOLD-IN RELAY
4CR	* FINAL RINSE SWITCH RELAY
5CR	* TABLE LIMIT SWITCH RELAY
6CR	* WASH TANK FLOAT SWITCH RELAY
7CR	* RINSE TANK FLOAT SWITCH RELAY
1M	* DRIVE CONTACTOR
1MOL	* DRIVE MOTOR OVERLOAD
2M	* WASH CONTACTOR
2MOL	* WASH MOTOR OVERLOAD
3M	* RINSE CONTACTOR
3MOL	* RINSE MOTOR OVERLOAD
4M	* MRA CONTACTOR
4MOL	* MRA MOTOR OVERLOAD
BC1	* BOOSTER HEATER CONTACTOR
CB	* CIRCUIT BREAKER
DSS	* DOOR SAFETY SWITCH
FRSW	* FINAL RINSE SWITCH
FRV	* FINAL RINSE FILL VALVE
FU-	* FUSE-TRANSFORMER
HC1	* WASH TANK HEAT CONTACTOR
HC2	* RINSE TANK HEAT CONTACTOR
HLRT	* HIGH LIMIT RINSE TANK
HLWT	* HIGH LIMIT WASH TANK
MSW	* MOTOR STOP SWITCH
MRA	* MACHINE RACK ADVANCE LIMIT SWITCH
PL	* POWER ON LIGHT
RFSW	* RINSE TANK FLOAT SWITCH
R	* RINSE TANK DOOR SAFETY SWITCH
RT	* RINSE TANK FLOAT TIMER
SW	* POWER SWITCH
T1	* 440V-120V TRANSFORMER
TB6	* WASH HEATER TERMINAL BLOCK
TB7	* RINSE HEATER TERMINAL BLOCK
TKL	* LOW TEMP INDICATOR LIGHT
TLS	* TABLE LIMIT SWITCH
TSB	* BOOSTER THERMOSTAT
TSK	* LOW TEMPERATURE CUT-OFF THERMOSTAT
TSR	* RINSE TANK THERMOSTAT
TSW	* WASH TANK THERMOSTAT
W	* WASH TANK DOOR SAFETY SWITCH
WFSW	* WASH TANK FLOAT SWITCH
WT	* WASH TANK FLOAT TIMER

- NOTES
1. REMOVE JUMPER ACROSS WIRES 70 AND 9 WHEN RACK ADVANCE TABLE IS USED.
 2. REMOVE JUMPER ACROSS N.O. 5CR CONTACT WHEN TABLE LIMIT SWITCH IS USED.

DIAGRAM STATE
POWER OFF
DOORS CLOSED
TANKS EMPTY
END OF CYCLE

C-57 Modified Booster Assembly
Beginning with S/N J08122570 and Above

CUSTOMER TO SUPPLY RATED VOLTAGE/PHASE/Hz, AS SPECIFIED PER ORDER. TO DISCONNECT SWITCH, ALL POWER SUPPLIED TO EACH CONNECTION POINT MUST COMPLY WITH ALL LOCAL ELECTRIC CODES.

DR. BY J MCALLISTER SCALE

DATE 14NOV08 SHEET 1 OF 1

REV.	DESCRIPTION	DATE	BY

REV.	DESCRIPTION	DATE	BY

Champion
The Dishwashing Machine Specialists

USN-72 ELECTRIC WITH HATCO INTERLOCK

B 702067 REV. 0

APPENDIXES

Service Bulletin:

Replacing Fenwal Thermostat P/N 100128 with Stemco Thermostat P/N 109069

USN72 Booster Conversion Instructions - Kit P/N 453393

Field Replacement of Champion Booster Model CH-60 Booster with Hatco C57 Booster

Hatco Model C57 Booster Service Parts

Form No. CXRP-0609 excerpted and used by permission

Contact:

Hatco Corporation P.O. Box 340500 Milwaukee, WI 53234-0500 USA for complete documentation.

Table Limit Switch Installation Instructions for Kit 418404

Form No. 900948

Champion[®]

The Dishwashing Machine Specialists

P.O. Box 4146
Winston-Salem, NC 27115
Tel: 336-661-1556
Fax: 336-661-1660
Tel: 800-858-4477

SERVICE BULLETIN

Stemco Thermostat Replacement

Navy Steam Boosters

Stemco Replaces Fenwall

January 20, 2003

REPLACING FENWAL THERMOSTAT P/N 100128 WITH STEMCO THERMOSTAT P/N 109069

For all Navy machines that are purchased with steam heated boosters. This notification is for the replacement of the thermostat in those boosters. To ensure that the thermostat is placed properly into the booster tank, please follow the diagram listed below. When replacing the the thermostat use part number 109069.

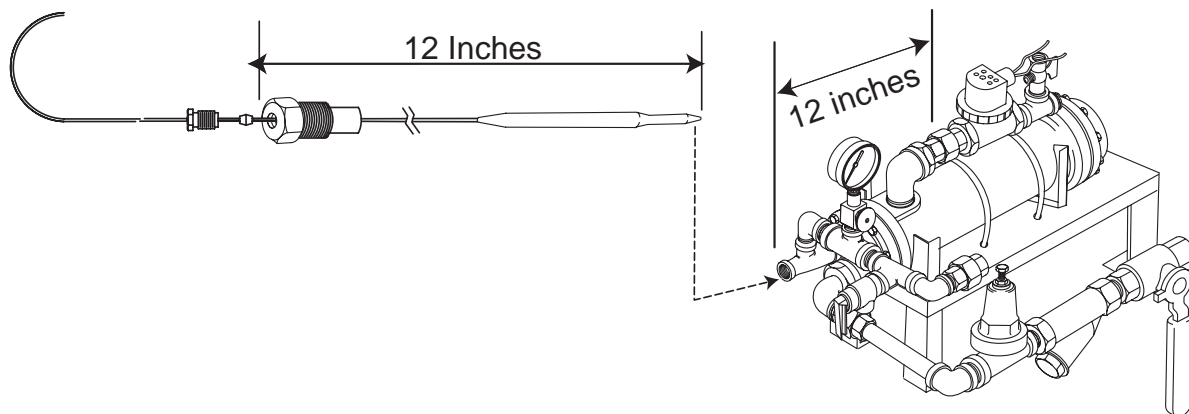

1. Mark off the measurement of 12 inches from the end of the bulb. This will be at the end of the 1/2" nut that mounts inside of the tee.
2. Insert the thermostat bulb 12 inches into the booster. Ensure that the bulb is inside one of the copper water tubes and not coiled up inside of the head. Place plumbers putty on the 1/2" nut. Tighten down the 1/2" nut inside of the tee.
3. Push the remaining capillary tube to the marking and tighten down the compression nut so as to lock down the furrell on the capillary. The thermostat replacement is now complete.

USN72 Booster Conversion Instructions

Field Replacement of Champion Booster Model CH-60
with the C57 Modified per application

Booster Conversion Kit Part No. 453393

Refer to the illustrations on the following pages to replace the existing CH-60 booster assembly with the booster assembly shipped in the Conversion Kit P/N 453393.

Contents

Safety Instructions	2
C57 Modified Utility Connections	3
Removing the Champion CH-60 Booster Assembly	4
Mounting the C57 Modified Booster Assembly	5
Parts List for the C57 Modified Left to Right Installation	6
Parts List for the C57 Modified Right to Left Installation	8
C57 Modified Electrical Connections	10
C57 Modified Operating Instructions.....	12
C57 Replacement Parts List	13
C57 Adjusting Thermostat Set-point	20
Electrical Schematics.....	23

Safety Instructions

IMPORTANT:

Plan the route used to transport the main booster assembly.

Make sure that all passageways and hatches provide the needed clearances to avoid damage to the main booster assembly.

NOTE:

The installation will require parts and materials that are not supplied by the factory, such as pipe sealing, water-proofing materials, and Type LSTSGU-3 Cable. Make sure that any materials are approved by your facility before the installation.

NOTE:

Observe all safety regulations and procedures when moving and placing the machine.

CAUTION:

To prevent damage to the machine, do not lift the machine by any of its piping or electrical conduit.



WARNING!

Electric shock may cause death or serious injury.

Do not work on energized circuits. Turn off all main power service disconnects, lock them out and place a tag on the switch and/or breaker to indicate that work is being performed on the circuit.

WARNING!

Death or serious injury may result if safety devices are not working.

NEVER operate the machine unless all safety devices are in good working condition and all safety covers are in place on the machine.

ATTENTION!

Utility connections must be performed by authorized installers who will follow all electrical, plumbing, sanitary, safety procedures and regulations.

C57 Modified Utility Connections

Refer to the Utility Diagrams below and familiarize yourself with the C57 Modified utility locations before removing the existing Champion CH-60 booster.

Utilities	
1	Hot water inlet 3/4" NPT 120°F/49°C for 60°F/33°C rise booster 20-25 PSI/137.8-173.8 kPa minimum flowing pressure measured at the booster.
2	Hot water outlet 3/4" NPT 180°F/82°C for 60°F/33°C rise booster 20-25 PSI/137.8-173.8 kPa minimum flowing pressure measured at the dishwasher.
3	Hot water temperature/pressure relief valve 3/4" NPT
4	Electrical connections Main power, 450VAC/60/3PH

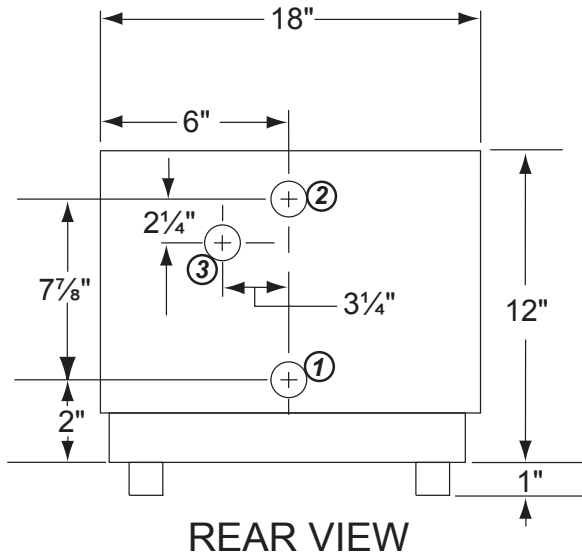
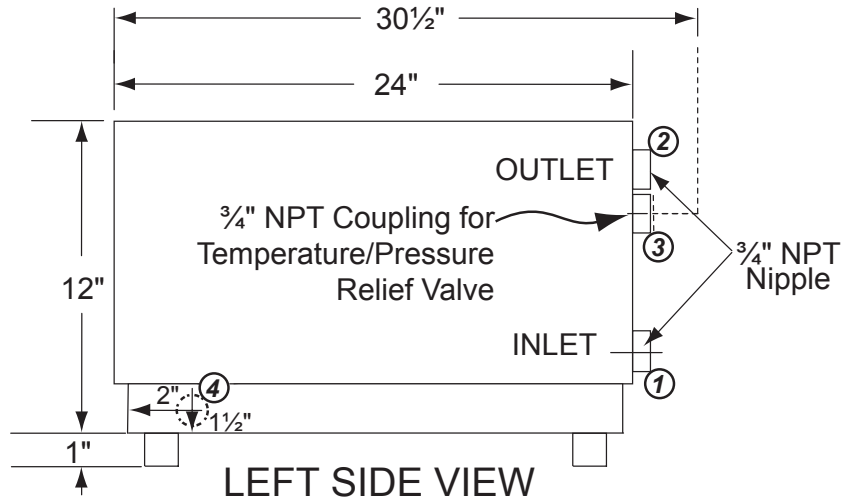

*Electrical Knock-outs
on the Lower Right-Side and the
Right bottom of the Booster*

Removing the Champion CH-60 Booster Assembly from the Top of the Dishwasher

1. Disconnect the plumbing from the existing booster
2. Retain the plumbing until the conversion is complete.
3. Disconnect the main power from the booster.
4. New sealtite and cable type LSTSGU-3 will be required by installing activities to convert the Fenwall High Limit Thermostat.
5. Disconnect the sealtite conduit and wires from the Fenwall High Limit Thermostat.
6. New sealtite and cable type LSTSGU-3 will be required by installing activities in order to rewire the control wiring to the C57 Modified booster.
7. Check the top interior of the dishwasher and locate the 4 bolts holding the CH60 booster to the top exterior of the machine.
8. Remove the bolts and carefully remove the CH-60 booster assembly from the top of the dishwasher.



Disconnect Existing plumbing from the CH-60 booster.

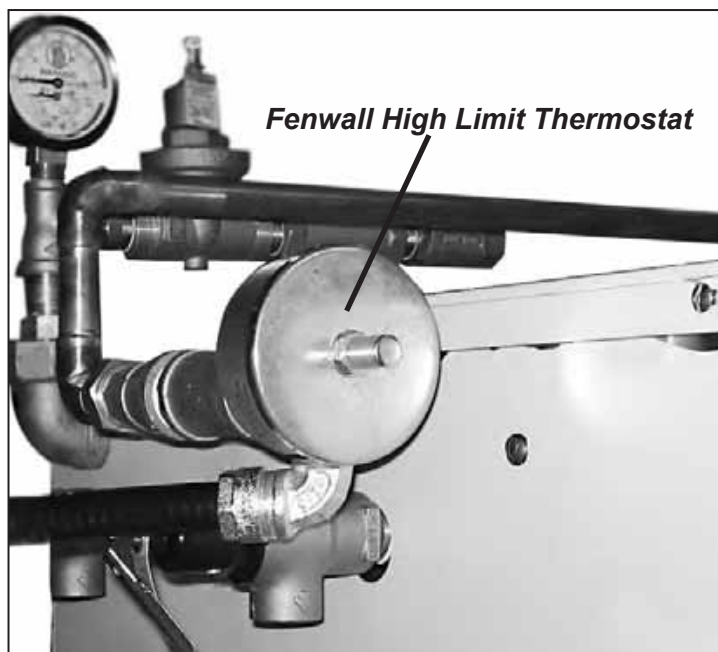

Disconnect Existing Wiring from the CH-60 booster.

Mounting the C57 Modified Booster Assembly to the Top of Dishwasher

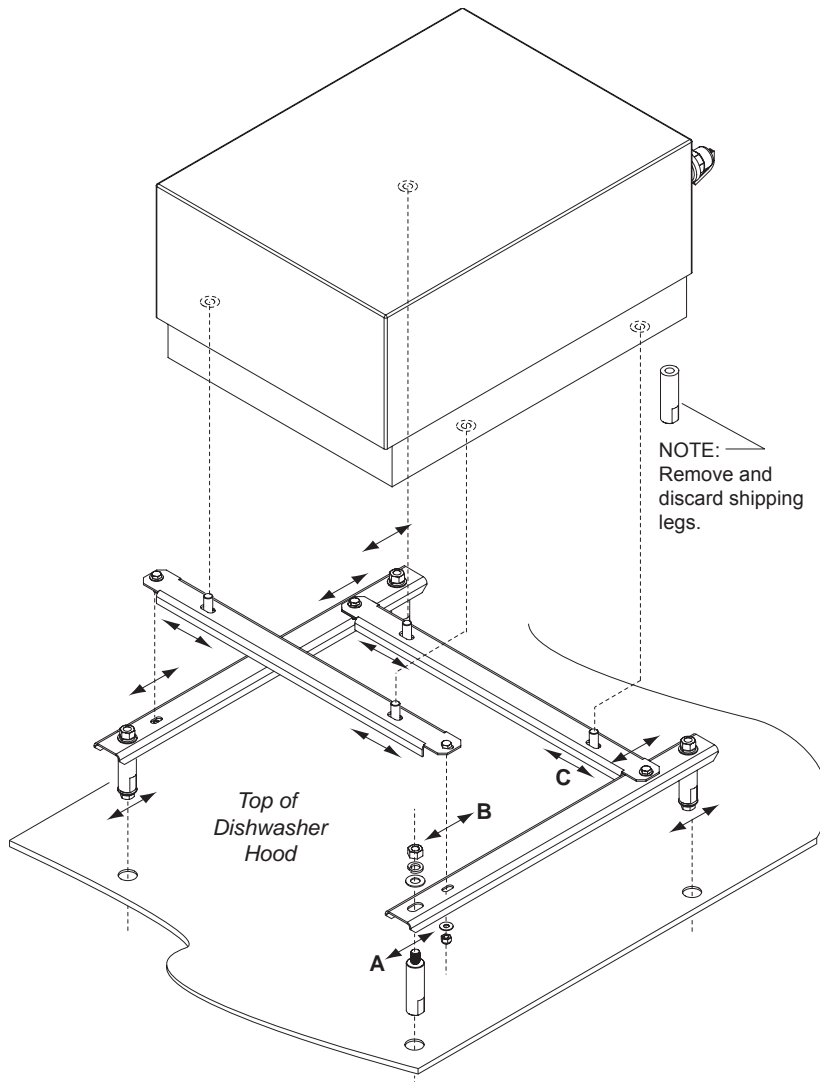

1. The booster is mounted to the top of dishwasher using 4 channels and hardware contained in the Kit.
2. The side channels are attached to the booster.
3. The front/rear channels are attached to the side channels.
4. Slots in the channels allow adjustments to be made when the channels are assembled. These slots are labeled A, B, and C in the illustration to the left.
5. The standoffs are attached to the side channels and are bolted to existing holes in the top of the dishwasher.

Parts List for the C57 Modified Left to Right Installation

Refer to the parts list below and the illustration on the next page to identify the components and assembly for the Left to Right Installation of the booster.

Item No.	Part No.	Description	Qty.
1	601902	PIPING, C57 STANDARD LR OUTLET	1
2	453403	HATCO C57 - MODIFIED BOOSTER	1
3	332668	CHANNEL, FRONT/REAR, BOOSTER SUPPORT	2
4	104584	HEX, PLAIN NUT, 1/2-13, SST	4
5	107589	WASHER, LOCK, 1/2 SPLIT, SST	12
6	104882	WASHER, FLAT, .531 X 1.062 X .062 SST	12
7	206921	STAND-OFF, BOOSTER SUPPORT, USN72	4
8	100747	BOLT, HEX HD., 1/2-13 X 1" SST	8
9	109009	HEX, GRIP NUT, 5/16-18 SST W/NYLON INSERT	4
10	102376	WASHER, FLAT, 5/16 X 3/4" X .05", SST	8
11	100740	BOLT, HEX HD., 5/16-18 X 1", SST	4
12	332667	CHANNEL, SIDE, BOOSTER SUPPORT, USN72	2

Parts List for the C57 Modified Left to Right Installation

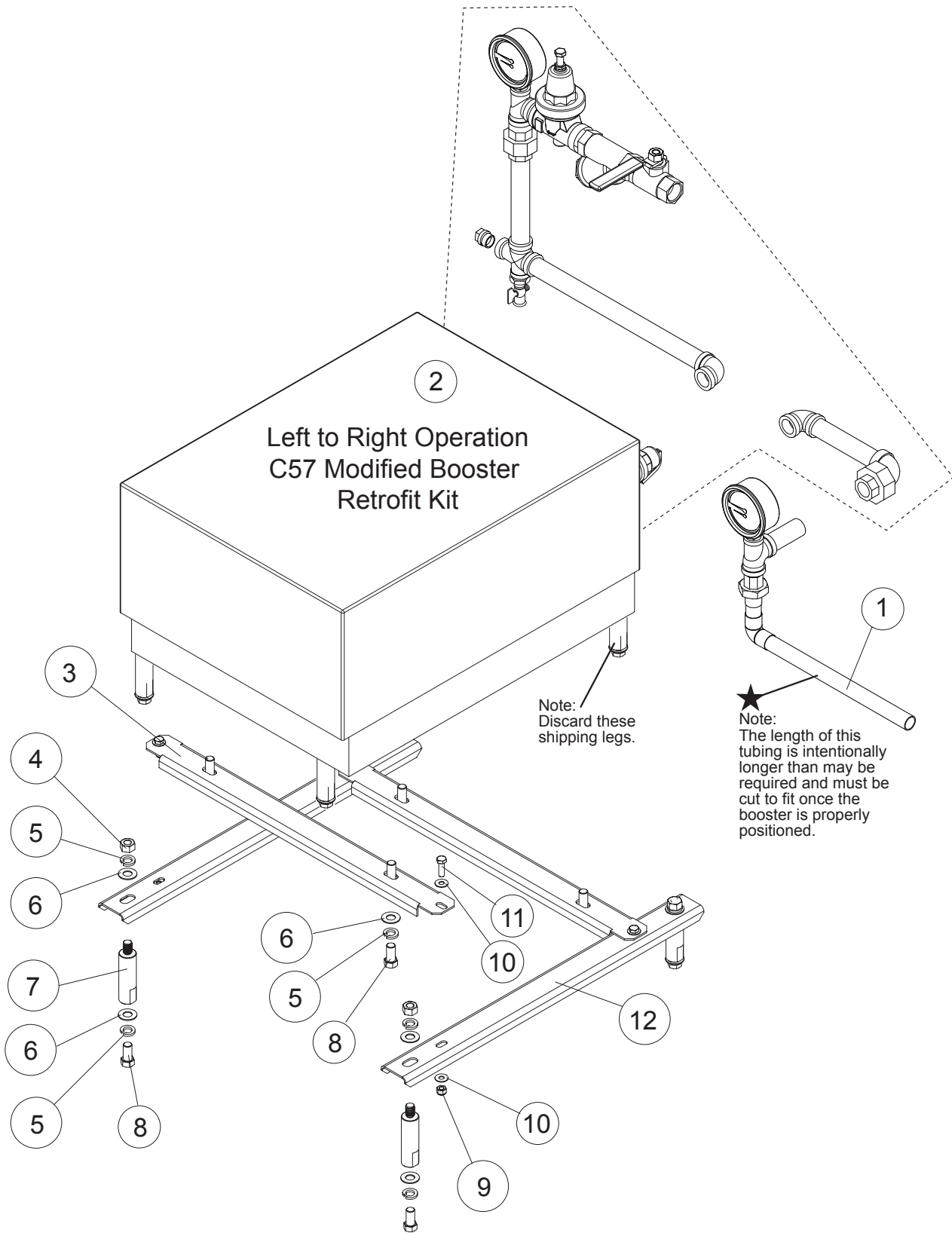

Parts List for the C57 Modified Right to Left Installation

Refer to the parts list below and the illustration on the next page to identify the components and assembly for the Right to Left Installation of the booster.

Item No.	Part No.	Description	Qty.
1	601903	PIPING, C57 STANDARD RL OUTLET	1
2	453403	HATCO C57 - MODIFIED BOOSTER	1
3	332668	CHANNEL, FRONT/REAR, BOOSTER SUPPORT	2
4	104584	HEX, PLAIN NUT, 1/2-13, SST	4
5	107589	WASHER, LOCK, 1/2 SPLIT, SST	12
6	104882	WASHER, FLAT, .531 X 1.062 X .062 SST	12
7	206921	STAND-OFF, BOOSTER SUPPORT, USN72	4
8	100747	BOLT, HEX HD., 1/2-13 X 1" SST	8
9	109009	HEX, GRIP NUT, 5/16-18 SST W/NYLON INSERT	4
10	102376	WASHER, FLAT, 5/16 X 3/4" X .05", SST	8
11	100740	BOLT, HEX HD., 5/16-18 X 1", SST	4
12	332667	CHANNEL, SIDE, BOOSTER SUPPORT, USN72	2

Parts List for the C57 Modified Right to Left Installation

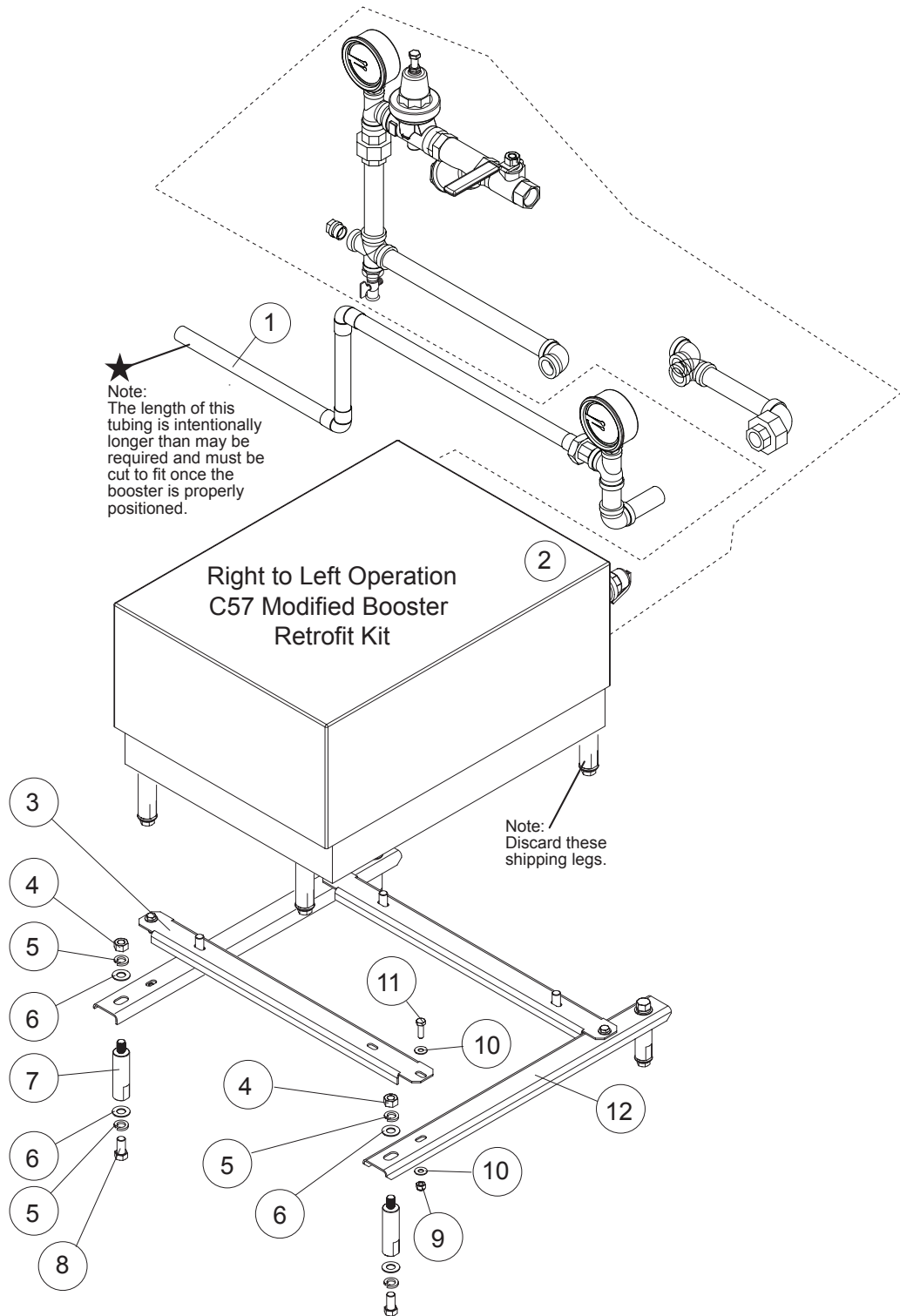

C57 Modified Electrical Connections

1. Electrical Connections are made inside the booster cabinet.
2. To open the cabinet remove 2 retaining screws on the sides of the cabinet.
3. Remove the retaining screw on the booster front access panel.
4. The front access panel is hinged on the bottom. Pull the panel forward and down to access the electrical connections.



Remove the side retaining screws

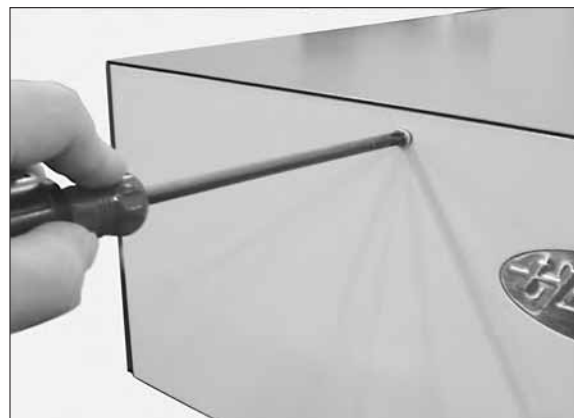

Remove the front retaining screw



Pull the front access panel forward

C57 Modified Electrical Connections

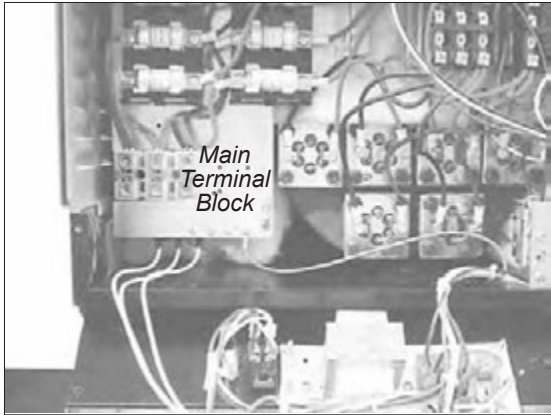

The main terminal block is located on the left-side of the booster cabinet interior.

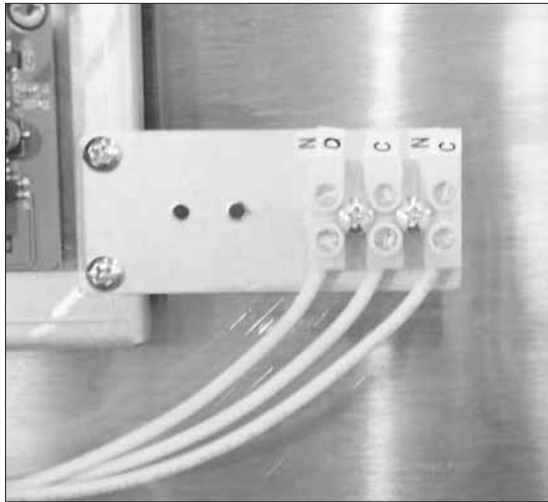

The Low temperature interlock block is located on the right-side of the booster cabinet interior.

1. Refer to the Installation & Operation Manual for the electrical specifications for the C57 Modified booster and connect the incoming power service at the main terminal block located on the left-side of booster cabinet.
2. Refer to the wiring diagram at the bottom of this page and connect the Low Temperature Interlock wires that were previously removed from the Champion CH-60 booster.
3. The Low Temperature Interlock connection block is located on the right-side of the booster cabinet.
4. Close the booster cabinet and refer to the Installation and Operating Manual for the C57 Modified booster.

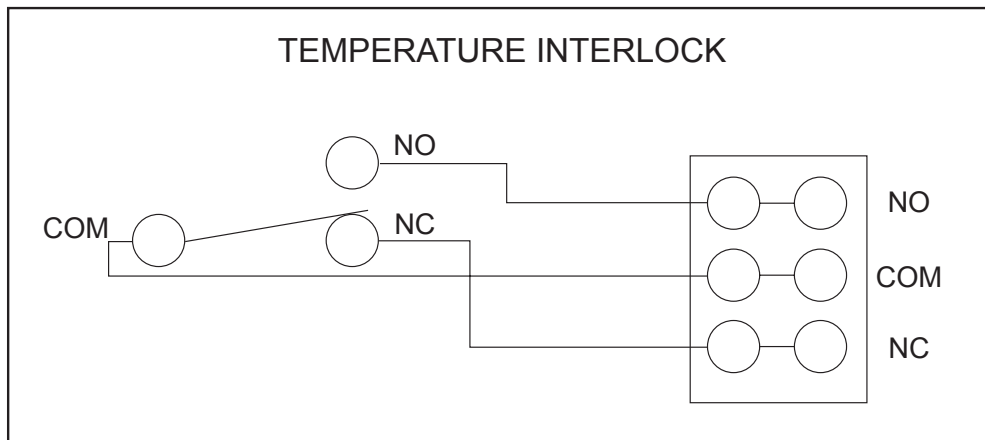

Low Temperature Interlock Switch Wiring Diagram

C57 Modified Operating Instructions

Installation and Operating Instructions published by the Hatco Corporation for the C57 Modified Booster are included in the Booster Assembly Kit. These instructions apply to more than one Booster Model. When referencing these instructions make sure that you are using the C57 version.



Electric Booster Water Heaters

Imperial "S"

Compact "C"

Mini-Compact "MC"

Series

Installation & Operating Manual

I&W #07.05.001.00

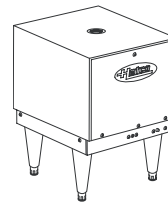
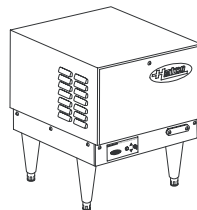
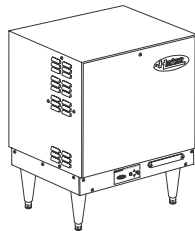

This manual contains important safety information concerning the maintenance, use and operation of this product. Failure to follow the instructions contained in this manual may result in serious injury. If you're unable to understand the contents of this manual, please bring it to the attention of your supervisor. Do not operate this equipment unless you have read and understood the contents of this manual.

Este manual contiene importante información sobre seguridad concerniente al mantenimiento, uso y operación de este producto. Cualquier falla en el seguimiento de las instrucciones contenidas en este manual puede resultar en un serio daño. Si usted no puede entender el contenido de este manual por favor pregunte a su supervisor. No opere este equipo al menos que haya leído y comprendido el contenido de este manual.



COMPACT BOOSTER Electric Water Heaters

C Series

C-57

The following pages are excerpted from
Hatco Form No. CXRP-0609, June 2009 and reprinted with permission.

Champion Industries, Inc. makes no claim or certification as to the accuracy of the information contained herein and is not responsible for errors, omissions, or updates.

Changes, revisions, and updates are the sole responsibility of Hatco Corporation and are available upon request from:

Hatco Corporation
P.O. Box 340500
Milwaukee, WI 53234-0500 U.S.A.

Toll-free: 1 (800) 558-0507
Tel: 1 (414) 671-6350
Parts &
Service Fax: 1 (800) 690-2966
Int'l Fax: 1 (414) 671-3976

REPLACEMENT PARTS LIST

**HATCO COMPACT ELECTRIC BOOSTER HEATER
C SERIES 4KW-58KW**

Model Designation
 C-XX C = Compact
 X = Kilowatts

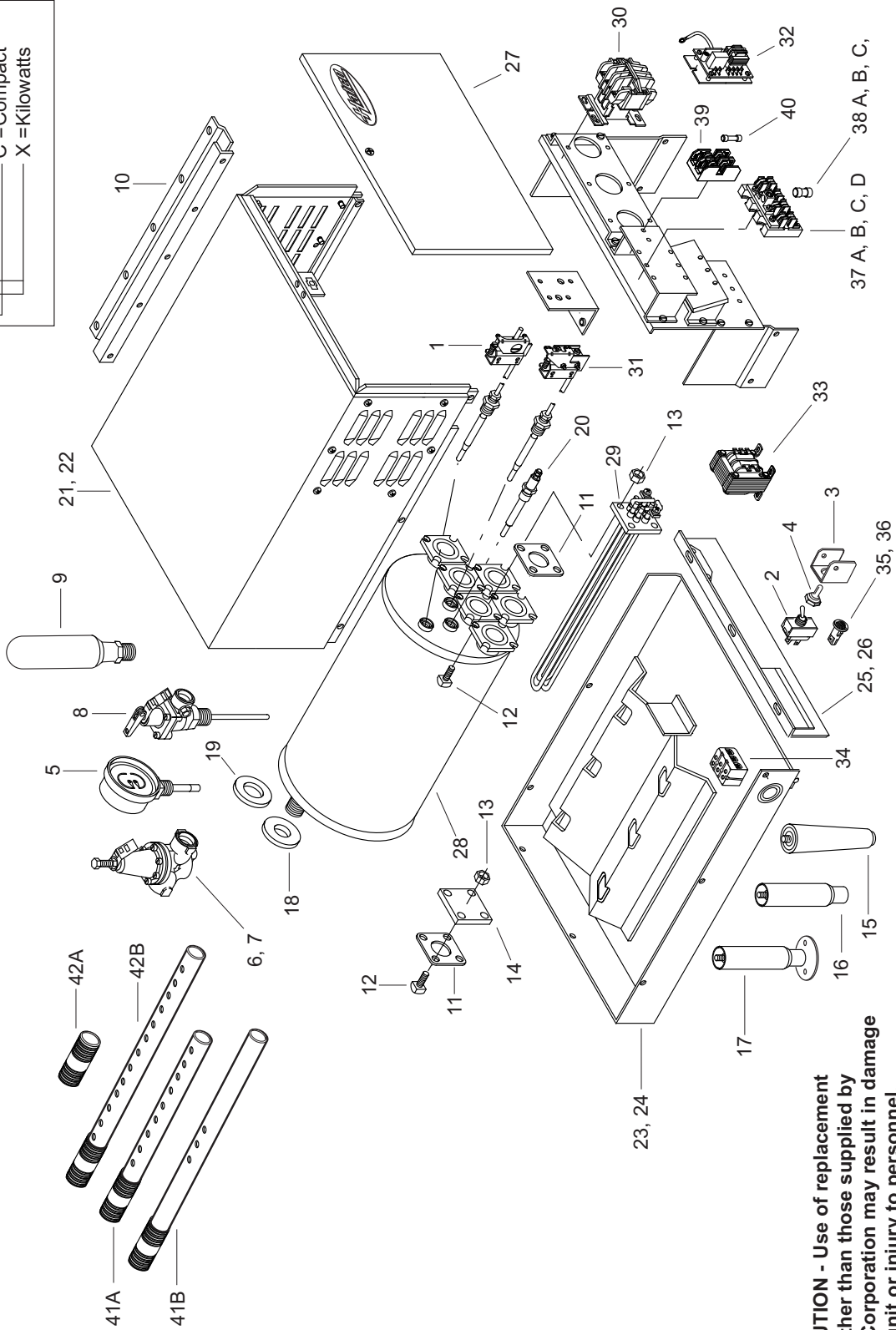

⚠ CAUTION - Use of replacement parts other than those supplied by Hatco Corporation may result in damage to the unit or injury to personnel.

**COMPACT BOOSTER
SHEET METAL BODY PARTS**

ITEM	DESCRIPTION	4KW-18KW	24KW-58KW
21	Jacket, Painted	R04.01.032.00	R04.01.220.00
22	Jacket, S.S. (Optional)	R04.01.034.00	R04.01.254.00
23	Base, Painted	R04.01.020P.00	R04.01.201P.00
24	Base, S.S. (Optional)	R04.01.022.00	R04.01.251.00
25	Base, Front, Painted	R04.01.033.00	R04.01.233.00
26	Base, Front, S.S. (Optional)	R04.01.035.00	R04.01.255.00
27	Front Cover, S.S.	R04.01.036.00	R04.01.221.00

NOTE: Part numbers listed for sheet metal body parts apply only to units manufactured during or after October 1996. Consult factory with model and serial number for units manufactured before October 1996.

**PARTS COMMON TO ALL
COMPACT BOOSTER MODELS
4KW-58KW**

ITEM	DESCRIPTION	PART NO.	QTY.
1	High Limit, Thermostat	02.16.116.00	1
2	On/Off Toggle Switch	R02.19.008A.00	1
3	Guard, Toggle Switch	04.01.038.00	1
4	Toggle Switch Boot, Rubber	02.20.040.00	1
5	Temperature/Pressure Gauge	03.01.003.00	2
6	Pressure Reducing Valve, Iron	03.02.004.00	1
7	Pressure Reducing Valve, Brass (Optional)	03.02.015.00	1
8	Temperature/Pressure Relief Valve	03.02.022.00	1
9	Shock Absorber (Optional)	03.40.057.00	1
10	Booster Slide Bracket Set	R04.20.030.00	1
11	Gasket, Heating Element	02.11.012.00	1-6
12	Bolt, Element Mounting	05.04.022.00	4-24
13	Nut, Element Mounting	05.04.028.00	4-24
14	Blank Element Flange with Gasket and Hardware	R02.11.013.00	1
15	Leg, Plastic	05.30.069.00*	4
16	Leg, S.S. (Optional)	05.30.070.00*	4
17	Deck Mount Legs, S.S. (Optional)	05.30.073.00*	4
18	Ring Seal, In/Out Pipe	05.06.006.00	2
19	Ring Seal, Relief Valve	05.06.017.00	1
20	Probe, Low Water Cut Off	02.40.001.00	1

* 4-18KW units manufactured with serial number 1021059907 or lower use part number 05.30.008.00 for the plastic leg, 04.01.013.00 for the S.S. leg and 04.01.014.00 for the S.S. deck mount leg. 24-58KW units manufactured with serial number 1017179907 or lower use part number 05.30.008.00 for the plastic leg, 4.01.013.00 for the S.S. leg and 04.01.014.00 for the S.S. deck mount leg.

NOTE: S.S. is an abbreviation for stainless steel.

PARTS SPECIFIC TO MODEL C-57

ITEM	DESCRIPTION	208V		240V		480V		208V		240V		480V		208V		240V	
		Single Phase	Three Phase	Single Phase	Three Phase	Single Phase	Three Phase	Single Phase	Three Phase	Single Phase	Three Phase	Single Phase	Three Phase	Single Phase	Three Phase	Single Phase	Three Phase
28	Tank with Gaskets	---	R01.02.031.00	---	R01.02.031.00	---	R01.02.031.00	---	R01.02.031.00	---	R01.02.031.00	---	R01.02.031.00	---	R01.02.031.00	---	R01.02.031.00
29	Heating Element with Gasket Quantity	---	R02.04.731.00 6	---	R02.04.733.00 6	---	R02.04.735.00 6	---	R02.04.731.00 6	---	R02.04.733.00 6	---	R02.04.735.00 6	---	R02.04.731.00 6	---	R02.04.731.00 6
30	Contacto Quantity	---	02.01.017.00 3	---	02.01.017.00 3	---	02.01.015.00 2	---	02.01.017.00 3	---	02.01.017.00 3	---	02.01.015.00 2	---	02.01.018.00 3	---	02.01.018.00 3
31	Thermostat Control	---	02.16.003.00	---	02.16.003.00	---	02.16.003.00	---	02.16.003.00	---	02.16.003.00	---	02.16.003.00	---	02.16.003.00	---	02.16.003.00
32	Low Water Cut Off Board	---	R02.01.210.00	---	R02.01.210.00	---	R02.01.210.00	---	R02.01.210.00	---	R02.01.210.00	---	R02.01.210.00	---	R02.01.210.00	---	R02.01.210.00
33	Transformer, Step Down	---	02.17.004.00	---	02.17.004.00	---	02.17.004.00	---	02.17.004.00	---	02.17.004.00	---	02.17.004.00	---	---	---	---
34	Terminal Block	---	---	---	---	---	02.15.021.00	---	---	---	---	---	02.15.021.00	---	---	---	02.15.021.00
35	Indicator Light, Red	---	02.19.154.00	---	02.19.154.00	---	02.19.154.00	---	02.19.154.00	---	02.19.154.00	---	02.19.154.00	---	02.19.151.00	---	02.19.151.00
36	Indicator Light, Green	---	---	---	---	---	---	---	---	---	---	---	---	---	---	---	02.19.150.00
37A	Power Fuse Block Quantity	---	02.41.020.00 2	---	02.41.020.00 2	---	02.41.020.00	---	02.41.020.00	---	02.41.020.00	---	02.41.020.00	---	---	---	---
37B	Power Fuse Block Quantity	---	02.41.022.00 1	---	02.41.022.00 1	---	02.41.022.00	---	02.41.022.00	---	02.41.022.00	---	02.41.022.00	---	---	---	---
37C	Power Fuse Block Quantity	---	---	---	---	---	02.41.030.00	---	---	---	02.41.030.00	---	02.41.030.00	---	---	---	---
37D	Power Fuse Block Quantity	---	---	---	---	---	---	---	---	---	---	---	---	---	---	---	---
38A	Power Fuse (2 Pack) (60 Amp) Quantity	---	R02.03.033.02 6	---	R02.03.033.02 6	---	---	---	---	---	---	---	---	---	---	---	---
38B	Power Fuse (2 Pack) (50 Amp) Quantity	---	---	---	---	---	---	---	R02.03.032.02 6	---	---	---	---	---	---	---	---
38C	Power Fuse (2 Pack) (50 Amp) Quantity	---	---	---	---	---	---	---	---	---	R02.03.012.02 3	---	---	---	---	---	---
39	Control Fuse Block	---	02.03.022.00	---	02.03.022.00	---	02.03.022.00	---	02.03.022.00	---	02.03.022.00	---	02.03.022.00	---	02.03.022.00	---	02.03.022.00
40	Control Fuse (2 Pack)	---	R02.03.014.02	---	R02.03.014.02	---	R02.03.014.02	---	R02.03.014.02	---	R02.03.014.02	---	R02.03.014.02	---	R02.03.014.02	---	R02.03.014.02
41A	Tube, Inlet Water	---	---	---	---	---	---	---	---	---	---	---	---	---	---	---	---
41B	Tube, Inlet Water	---	03.30.007.00	---	03.30.007.00	---	03.30.007.00	---	03.30.007.00	---	03.30.007.00	---	03.30.007.00	---	03.30.007.00	---	03.30.007.00
42A	Nipple, Outlet Water	---	---	---	---	---	---	---	---	---	---	---	---	---	---	---	---
42B	Tube, Outlet Water	---	03.30.009.00	---	03.30.009.00	---	03.30.009.00	---	03.30.009.00	---	03.30.009.00	---	03.30.009.00	---	03.30.009.00	---	03.30.009.00
	Electrical Diagram	---	10-01-437A	---	10-01-437A	---	10-01-434A	---	10-01-437A	---	10-01-434A	---	10-01-437A	---	10-01-438A	---	10-01-438A

Shaded area reflects export models only.

PARTS SPECIFIC TO MODEL C-57										
ITEM	DESCRIPTION	240V Three Phase	380V Three Phase	415V Three Phase	480V Three Phase	600V Three Phase	380-400V CE 3 Wire	400-415V CE 3 Wire	380-400V CE 4 Wire	400-415V CE 4 Wire
28	Tank with Gaskets	R01.02.031.00	R01.02.031.00	R01.02.031.00	R01.02.031.00	R01.02.031.00	---	---	---	---
29	Heating Element with Gasket Quantity	R02.04.733.00 6	R02.04.732.00 6	R02.04.733.00 6	R02.04.735.00 6	R02.04.734.00 6	---	---	---	---
30	Contactors Quantity	02.01.018.00 3	02.01.016.00 2	02.01.016.00 2	02.01.016.00 2	02.01.016.00 1	---	---	---	---
31	Thermostat Control	02.16.003.00	02.16.003.00	02.16.003.00	02.16.003.00	02.16.003.00	---	---	---	---
32	Low Water Cut Off Board	R02.01.210.00	R02.01.210.00	R02.01.210.00	R02.01.210.00	R02.01.210.00	---	---	---	---
33	Transformer, Step Down	---	R02.17.003.00	R02.17.059.00	R02.17.059.00	02.17.059.00	---	---	---	---
34	Terminal Block	02.15.021.00	02.15.021.00	02.15.021.00	02.15.021.00	02.15.021.00	---	---	---	---
35	Indicator Light, Red	02.19.151.00	02.19.151.00	02.19.151.00	02.19.151.00	02.19.151.00	---	---	---	---
36	Indicator Light, Green	02.19.150.00	02.19.150.00	02.19.150.00	02.19.150.00	02.19.150.00	---	---	---	---
37A	Power Fuse Block Quantity	---	---	---	---	---	---	---	---	---
37B	Power Fuse Block Quantity	---	---	---	---	---	---	---	---	---
37C	Power Fuse Block Quantity	---	---	---	---	---	---	---	---	---
37D	Power Fuse Block Quantity	---	---	---	---	---	---	---	---	---
38A	Power Fuse (2 Pack) Quantity	---	---	---	---	---	---	---	---	---
38B	Power Fuse (2 Pack) Quantity	---	---	---	---	---	---	---	---	---
38C	Power Fuse (2 Pack) Quantity	---	---	---	---	---	---	---	---	---
39	Control Fuse Block	02.03.022.00	02.03.022.00	02.03.022.00	02.03.022.00	02.03.022.00	---	---	---	---
40	Control Fuse (2 Pack)	R02.03.014.02	R02.03.005A.02	R02.03.005A.02	R02.03.005A.02	R02.03.005A.02	---	---	---	---
41A	Tube, Inlet Water	---	---	---	---	---	---	---	---	---
41B	Tube, Inlet Water	03.30.007.00	03.30.007.00	03.30.007.00	03.30.007.00	03.30.007.00	---	---	---	---
42A	Nipple, Outlet Water	---	---	---	---	---	---	---	---	---
42B	Tube, Outlet Water	03.30.009.00	03.30.009.00	03.30.009.00	03.30.009.00	03.30.009.00	---	---	---	---
	Electrical Diagram	10-01-438A	10-01-439A	10-01-439A	10-01-435A	10-01-439A	---	---	---	---

Shaded area reflects export models only.

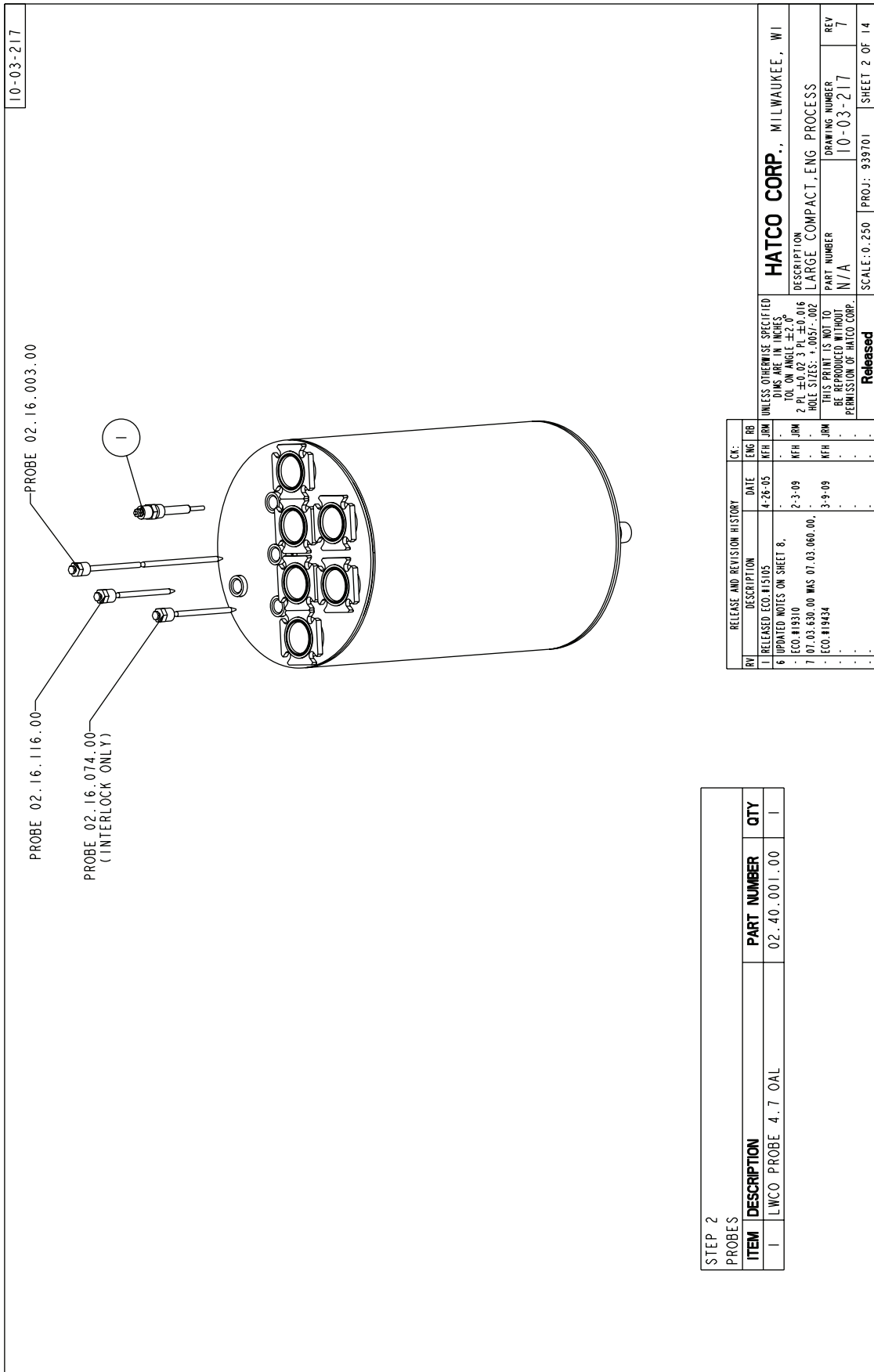

10-03-217

PROBE 02.16.116.00

PROBE 02.16.074.00
(INTERLOCK ONLY)

1

ITEM	DESCRIPTION	PART NUMBER	QTY
1	LWCO PROBE 4.7 OAL	02.40.001.00	1

RV	DESCRIPTION	DATE	ENG	RB
1	RELEASED ECO #15105	4-28-05	MFH	JRM
6	UPDATED NOTES ON SHEET 8, ECO #19310	2-3-09	MFH	JRM
7	07.03.630.00 WAS 07.03.060.00, ECO #19434	3-9-09	MFH	JRM

RELEASE AND REVISION HISTORY	CK:
UNLESS OTHERWISE SPECIFIED DIMENSIONS ARE IN INCHES TOLERANCES: 2 PL ±0.02 3 PL ±0.016 HOLE SIZES: +.005/- .002	ENG RB
THIS PRINT IS NOT TO BE REPRODUCED WITHOUT PERMISSION OF HATCO CORP.	MFH JRM
Released	

HATCO CORP., MILWAUKEE, WI
DESCRIPTION LARGE COMPACT, ENG PROCESS
PART NUMBER N/A
DRAWING NUMBER 10-03-217
REV 7
SCALE: 0.250
PROJ: 939701
SHEET 2 OF 14

10-03-217

NOTE:
 USE ON TEMPERATURE INTERLOCK ONLY
 02.16.074.00
 05.04.007.00 2PCS

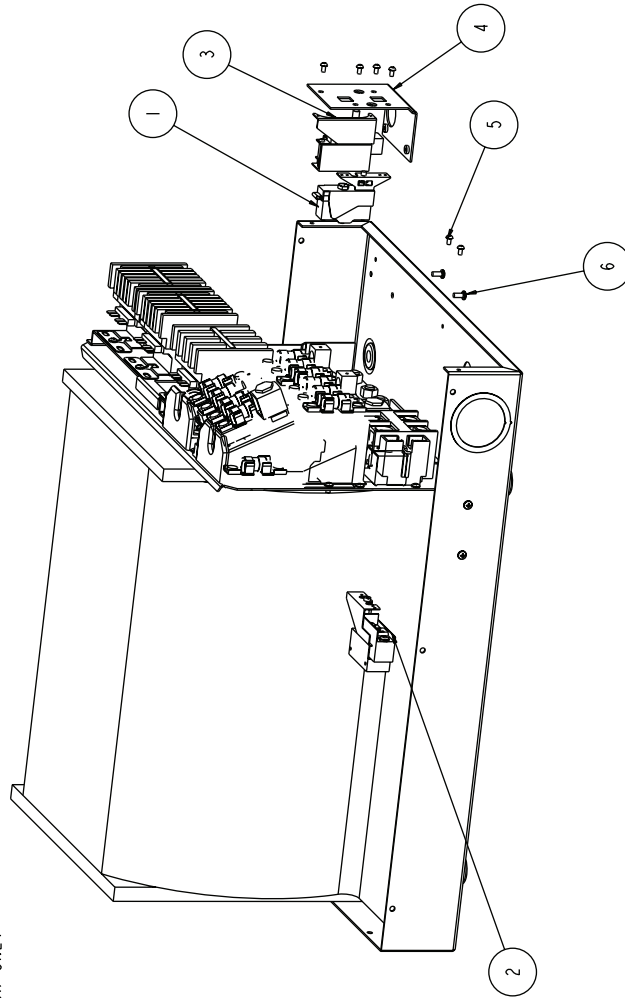

STEP 7
 T-STATS

ITEM	DESCRIPTION	PART NUMBER	QTY
1	T-STAT, CONTROL, MECHANICAL WET, 112°F. - 192°F.	02.16.003.00	1
2	T-STAT, CONTROL, MECHANICAL, WET, 180°F, INTRLK	02.16.074.00	1
3	T-STAT, HI LIMIT, BOOSTERS	02.16.116.00	1
4	THERM HI-LMT MOUNTING BRACKET LG & SM CM	04.01.284.00	1
5	SC PLT 6-32X.250 RD PH MACH ZNC	05.04.007.00	6
6	SC PLT 8-32X3/8 PH PAN ROLOK	05.04.010.00	2

RV	DESCRIPTION	DATE	ENG	BR
1	RELEASED ECO.#15105	4-28-05	MFH	JRM
6	UPDATED NOTES ON SHEET 8, ECO.#19310	2-3-09	MFH	JRM
7	07.03.630.00 WAS 07.03.060.00, ECO.#19434	3-9-09	MFH	JRM

UNLESS OTHERWISE SPECIFIED
 DIMENSIONS ARE IN INCHES
 TOLERANCES UNLESS NOTED
 2 PL ±0.02 3 PL ±0.016
 HOLE SIZES ±.005/- .002
 THIS PRINT IS NOT TO
 BE REPRODUCED WITHOUT
 PERMISSION OF HATCO CORP.

HATCO CORP., MILWAUKEE, WI
 DESCRIPTION
 LARGE COMPACT, ENG PROCESS
 PART NUMBER
 N/A
 DRAWING NUMBER
 10-03-217
 REV
 7
 SCALE: 0.250 | PROJ.: 939701 | SHEET 7 OF 14

ADJUSTING THERMOSTAT SET-POINT

GENERAL

⚠ WARNING

To avoid any injury or damage to the booster heater turn the power OFF at the disconnect switch/circuit breaker and allow to cool before performing any maintenance or adjustments.

THERMOSTAT

Thermostat Adjustment

The thermostat is factory calibrated to produce temperatures of 185°-190°F (85°-88°C). If adjustment or recalibration is required use the following procedure. (See Figures 18 and 19.)

NOTE: Low Temperature Dishmachines require the thermostat(s) to be adjusted to 140°-150°F (60°-66°C).

1. Remove the access cover.

To **lower** the temperature setpoint, turn the outer adjustment screw counterclockwise.

To **raise** the temperature setpoint, turn the outer adjustment screw clockwise.

NOTE: 1/6 turn of the outer screw equals 12°F (6.7°C).

If recalibration is necessary, with the outer screw at high stop turn inner adjustment screw clockwise to raise the set point.

NOTE: 1/6 turn of the inner screw equals 8°F (4.4°C).

HIGH TEMPERA TURE LIMIT SAFETY SWITCH

All Hatco Electric Booster Water Heaters are equipped with a manually reset high temperature limit safety switch. If the temperature of the water in the heater exceeds 210°F (99°C) the safety switch will shut off the power. The switch must be manually reset by pushing the red button.

If the high temperature limit safety switch needs to be reset use the following procedure (See Figures 18 and 20.):

1. Remove access cover.
2. Push red reset button.
3. If tripping repeats, call an Authorized Service Agent.

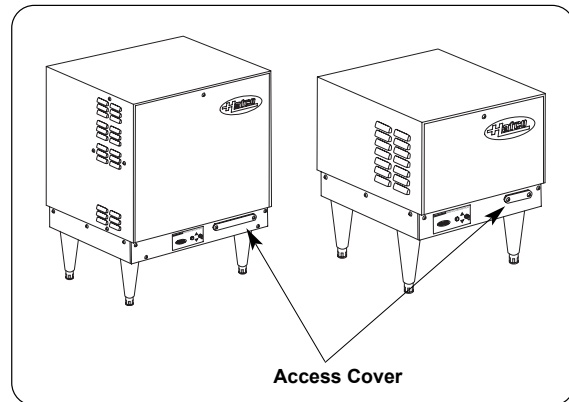

Figure 18. Access Cover for Thermostat(s) and High Temperature Limit Safety Switch

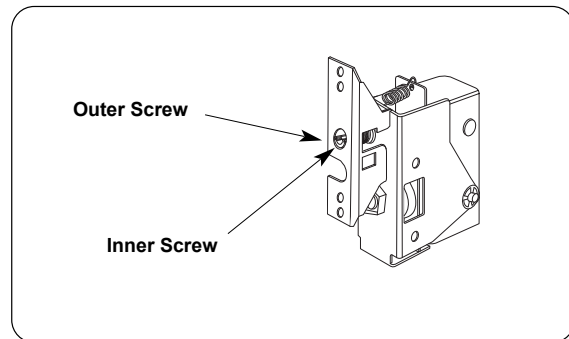

Figure 19. Thermostat Adjustment

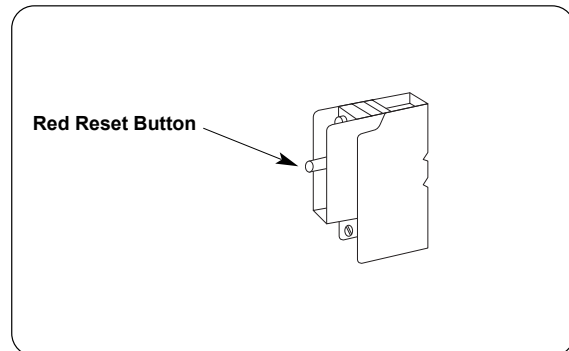

Figure 20. High Temperature Limit Safety Switch

HATCO AUTHORIZED PARTS DISTRIBUTORS

ALABAMA

Jones McLeod Appl. Svc.
Birmingham 205-251-0159

ARIZONA

Service Solutions Group
Phoenix 602-234-2443

Byassee Equipment Co.
Phoenix 602-252-0402

CALIFORNIA

Industrial Electric
Commercial Parts & Service, Inc.
Huntington Beach 714-379-7100

Chapman Appl. Service
San Diego 619-298-7106

P & D Appliance
Commercial Parts & Service, Inc.
S. San Francisco 650-635-1900

COLORADO

Hawkins Commercial Appliance
Englewood 303-781-5548

FLORIDA

Whaley Foodservice Repair
Jacksonville 904-725-7800

Nass Service Co., Inc.
Orlando 407-425-2681

B.G.S.I.
Pompano Beach 954-971-0456

Comm. Appliance Service
Tampa 813-663-0313

GEORGIA

TWC Services
Smyrna 770-438-9797

Heritage Service Group
Norcross 866-388-9837

Southeastern Rest. Svc.
Norcross 770-446-6177

HAWAII

Burney's Comm. Service, Inc.
Honolulu 808-848-1466

Food Equip Parts & Service
Honolulu 808-847-4871

ILLINOIS

Parts Town
Lombard 708-865-7278

Eichenauer Elec. Service
Decatur 217-429-4229

Midwest Elec. Appl. Service
Elmhurst 630-279-8000

Cone's Repair Service
Moline 309-797-5323

INDIANA

GCS Service
Indianapolis 317-545-9655

IOWA

Electric Motor Service Co.
Davenport 319-323-1823

Goodwin Tucker Group
Des Moines 515-262-9308

KENTUCKY

Service Solutions Group
Lexington 859-254-8854

Service Solutions Group
Louisville 502-451-5411

LOUISIANA

Chandlers Parts & Service
Baton Rouge 225-272-6620

MARYLAND

Electric Motor Service
Baltimore 410-467-8080

GCS Service
Silver Spring 301-585-7550

MASSACHUSETTS

Ace Service Co., Inc.
Needham 781-449-4220

MICHIGAN

Bildons Appliance Service
Detroit 248-478-3320

Commercial Kitchen Service
Bay City 517-893-4561

Midwest Food Equip. Service
Grandville 616-261-2000

MINNESOTA

GCS Service
Plymouth 800-345-4221

MISSOURI

General Parts
Kansas City 816-421-5400

Commercial Kitchen Services
St. Louis 314-890-0700

Kaemmerlen Parts & Service
St. Louis 314-535-2222

NEBRASKA

Anderson Electric
Omaha 402-341-1414

NEVADA

Burney's Commercial
Las Vegas 702-736-0006

Hi. Tech Commercial Service
N. Las Vegas 702-649-4616

NEW JERSEY

Jay Hill Repair
Fairfield 973-575-9145

Service Plus
Flanders 973-691-6300

NEW YORK

Acme American Repairs, Inc.
Brooklyn 718-456-6544

Alpro Service Co.
Brooklyn 718-386-2515

Appliance Installation
Buffalo 716-884-7425

Duffy's Equipment Services, Inc.
Buffalo 800-836-1014

3Wire Northern
Plattsburgh 800-634-5005

Duffy's Equipment Services, Inc.
Sauquoit 800-836-1014

J.B. Brady, Inc.
Syracuse 315-422-9271

NORTH CAROLINA

Authorized Appliance
Charlotte 704-377-4501

OHIO

Akron/Canton Comm. Svc. Inc.
Akron 330-753-6635

Service Solutions Group
Cincinnati 513-772-6600

Commercial Parts and Service
Columbus 614-221-0057

Electrical Appl. Repair Service
Independence 216-459-8700

E. A. Wichman Co.
Toledo 419-385-9121

OKLAHOMA

Hagar Rest. Service, Inc.
Oklahoma City 405-235-2184

Krueger, Inc.
Oklahoma City 405-528-8883

OREGON

Ron's Service, Inc.
Portland 503-624-0890

PENNSYLVANIA

Elmer Schultz Services
Philadelphia 215-627-5401

FAST Comm. Appl. Service
Philadelphia 215-288-4800

Appliance Installation & Service
Pittsburgh 412-809-0244

K & D Service Co.
Harrisburg 717-236-9039

Electric Repair Co.
Reading 610-376-5444

RHODE ISLAND

Marshall Electric Co.
Providence 401-331-1163

SOUTH CAROLINA

Whaley Foodservice Repair
W. Columbia 803-791-4420

TENNESSEE

Camp Electric
Memphis 901-527-7543

TEXAS

GCS Service
Fort Worth 800-433-1804

Armstrong Repair Service
Houston 713-666-7100

Cooking Equipment Specialist
Mesquite 972-686-6666

Commercial Kitchen Repair Co.
San Antonio 210-735-2811

UTAH

La Monica's Rest. Equip. Service
Murray 801-263-3221

VIRGINIA

Daubers
Norfolk 757-855-4097

Daubers
Springfield 703-866-3600

WASHINGTON

3Wire Restaurant Appliance
Seattle 866-770-2022

WISCONSIN

A.S.C., Inc.
Madison 608-246-3160

A.S.C., Inc.
Milwaukee 414-543-6460

CANADA

ALBERTA

Key Food Equipment Service
Edmonton 780-438-1690

BRITISH COLUMBIA

Key Food Equipment Service
Vancouver 604-433-4484

Key Food Equipment Service
Victoria 250-920-4888

MANITOBA

Air Rite, Inc.
Winnipeg 204-895-2300

NEW BRUNSWICK

EMR Services, Ltd.
Moncton 506-855-4228

ONTARIO

R.G. Henderson Ltd.
Toronto 416-422-5580

Choquette - CKS, Inc.
Ottawa 613-739-8458

QUÉBEC

Choquette - CKS, Inc.
Montreal 514-722-2000

Choquette - CKS, Inc.
Québec City 418-681-3944

UNITED KINGDOM

Marren Group
Northants +44(0)1933 666233



***This Page
Intentionally
Left Blank***

Table Limit Switch (TLS) Installation Instructions for Service Kit P/N 418404

NOTE:

These instructions pertain to USN72 Rack Conveyor Dishwashers.

! ATTENTION !

This Kit will not work if the distance between the backsplash and the wall is less than 1-7/8" [48mm].
See Section 1: Checking Wall Clearance before beginning the TLS installation.

Introduction: A table limit switch (TLS) should be installed on the dishwasher unload dish table to prevent dishwasher conveyor jams if dish racks accumulate as they exit the dishwasher. The TLS shuts down the dishwasher conveyor drive until dish racks are removed.

Section 1: Check Wall Clearance

Before beginning the installation, measure the distance from the wall to the dish table backsplash. The minimum clearance is 1-7/8" [48mm]. See Fig. 1 below.

This kit will not work if the proper clearance is unavailable.

Fig. 1 -
Check wall to backsplash clearance

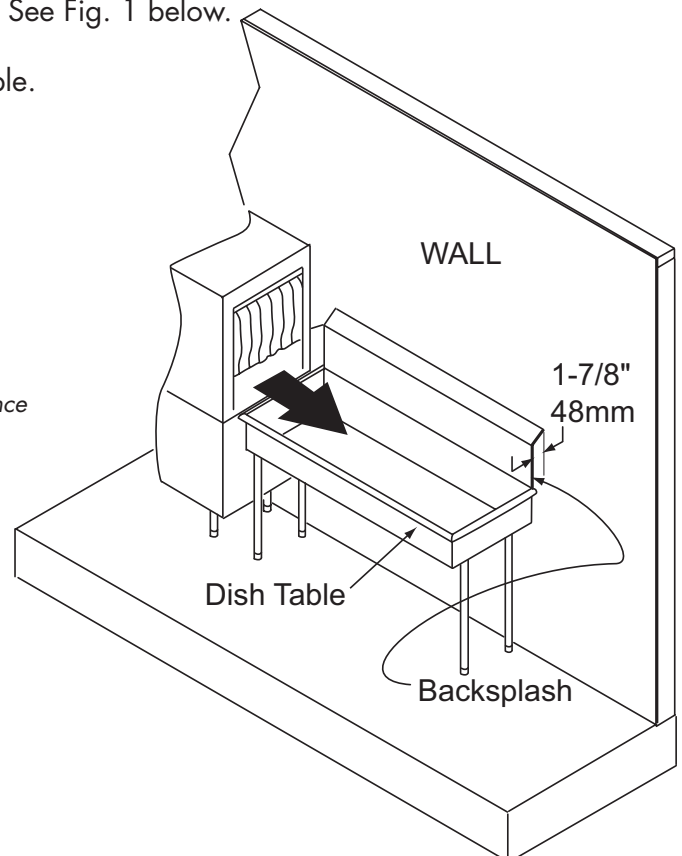

Section 2: Parts and Special Tools

Kit Contents: This kit contains the following parts.

<u>Qty.</u>	<u>P/N</u>	<u>Description</u>
1	330764	Bracket, Table Limit Switch
1	114247	TLS Body w/contact block
1	114248	TLS Actuator 90° Head
1	114249	TLS Clamp and Rod
1	114250	TLS Sealtite Gland, 1/2"
1	114251	TLS Nylon Rod, 6mm x 12" Lg.
2	114004	Screw, 10-32 x 1/4" Slotted Hex Hd.
2	100007	Screw, 10-32 x 3/8" Truss Hd.
1	111167	Paper Template for marking holes
1	900947	Instruction Sheet

Note:

Contact your parts supplier if any parts are missing from this kit.

Additional Parts and Special Tools Needed:

<u>Qty.</u>	<u>P/N</u>	<u>Description</u>
A/R*		Flexible nonmetallic liquid tight 1/2" conduit
A/R*		#14 gauge wire (2 conductors)
A/R*		Cable ties
4		#6 stud size spade terminals
1		Straight 1/2" liquid tight conduit fitting
1		Elbow, 90° 1/2" liquid tight conduit fitting
1		7/8" Knock-out punch capable of cutting stainless steel

* Exact lengths and quantities depend on length of dish table and conduit routing.

Section 3: Drilling and Cutting the Dish Table

1. Refer to Fig. 2, *Paper Drilling Template*, below.
2. Fold the paper template, included in the kit, along the dotted line and place the template on the inside bottom end of the dish table with the printed side visible.
3. Mark and drill the holes according to the direction of operation for your dishwasher (L to R or R to L dishwasher operation). See Fig. 3, *TLS Orientation*, below.
4. Mark and cut a 7/8" hole using a knock-out punch in the appropriate location.

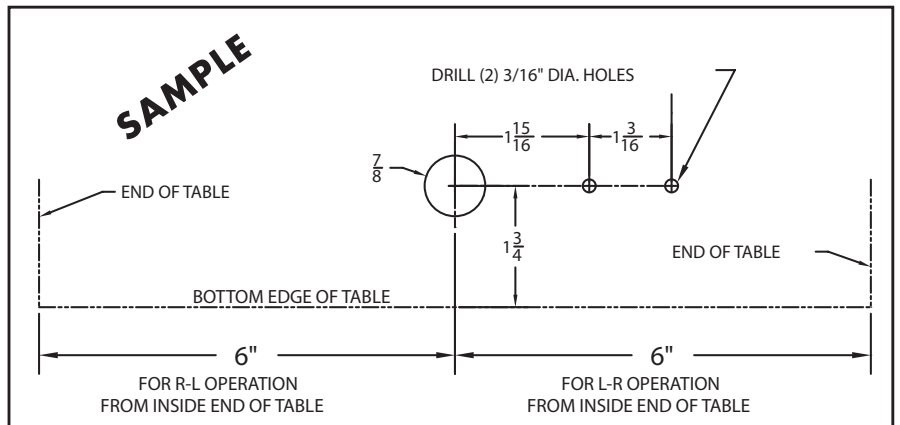

Fig. 2 -
Paper Drilling Template

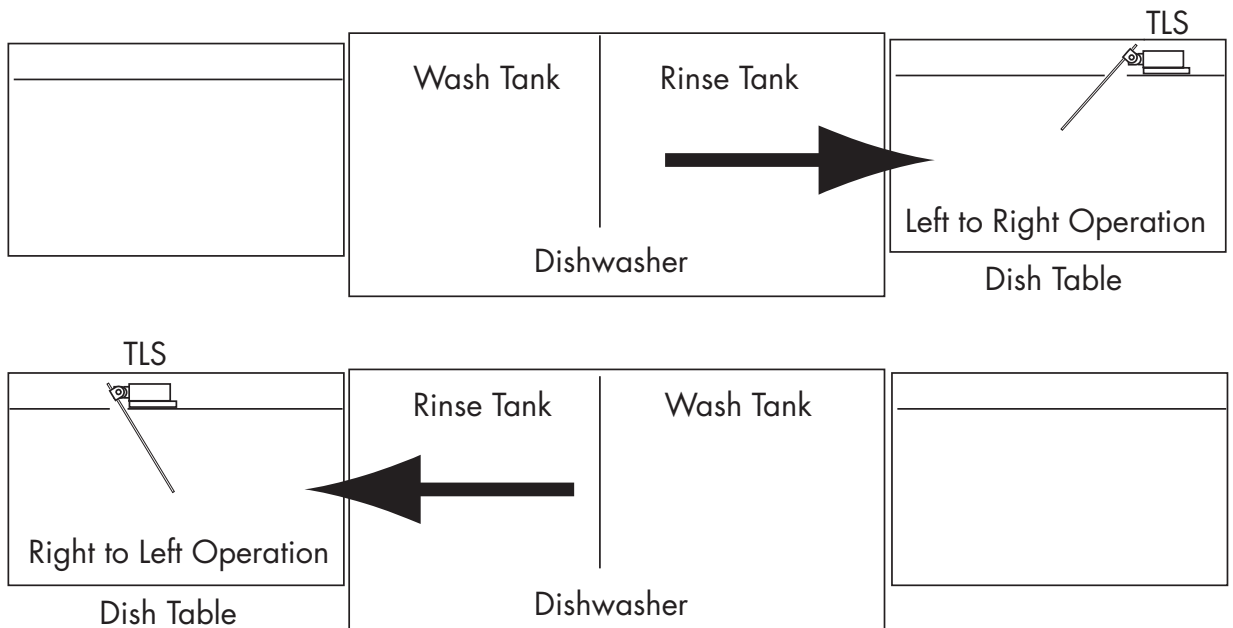

Fig. 3 -
TLS Orientation
(Drawing Not to Scale)

Section 4: Assembling the Table Limit Switch

1. Refer to Fig. 4, *TLS and Mounting Bracket*, below.

Part (A) is the switch body, Part (B) is the actuator head/nylon rod installed on the switch body, and Part (C) is the bracket which mounts the TLS assembly to the back of the dish table. The long screws attach the TLS to the bracket and the short screws mount the bracket to the dish table.

Refer to Fig. 5, *Assembling the TLS* below.

To assemble the TLS:

- a. Remove Screw (A) and remove the TLS cover.
- b. With a flat blade screwdriver, gently pull the Retaining Clip (B) forward.
- c. Insert the Actuator Head (C) into the switch body then push the retaining clip back into place to hold the actuator.
- d. Screw the Clamp with Nylon Rod (D) to the actuator head.

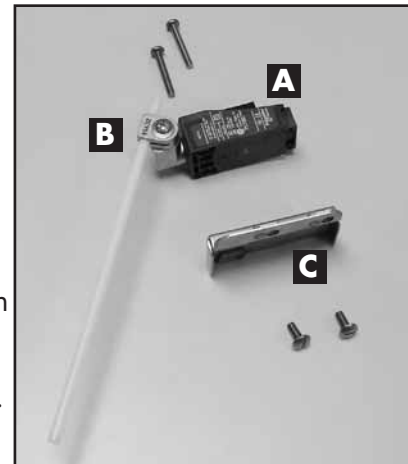

Fig. 4 -
TLS and Mounting Bracket

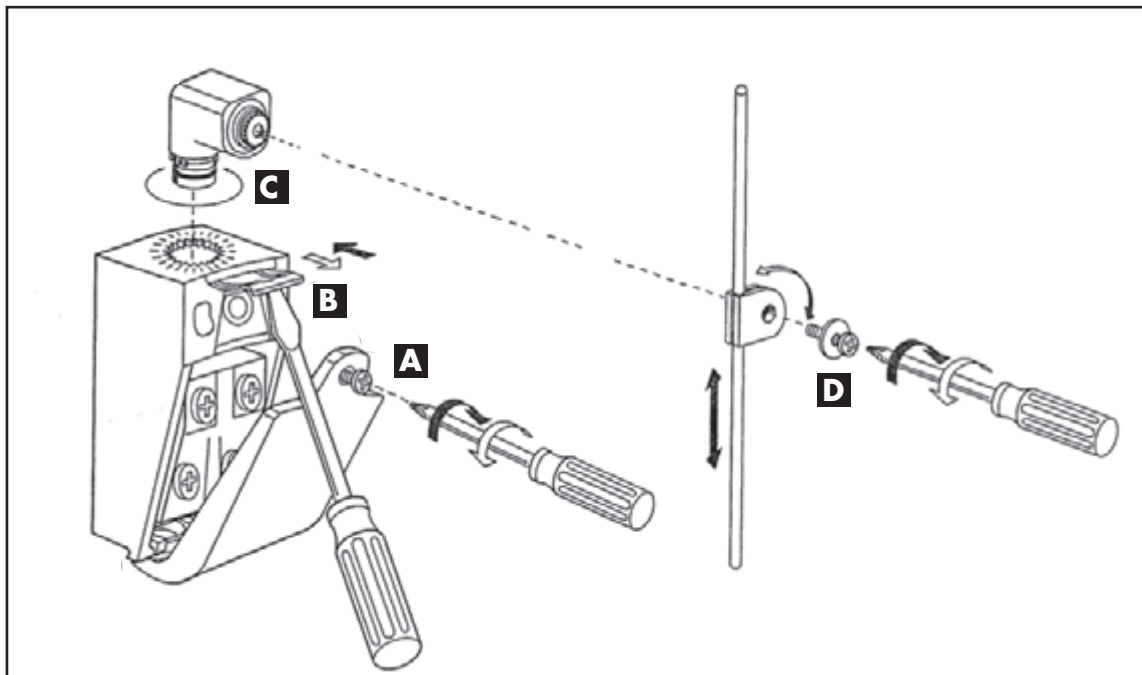

Fig. 5 -
Assembling the TLS

Section 4: Assembling the Table Limit Switch *(continued)*

2. Refer to Fig. 6, *Installing the TLS Conduit Adapter*, below.
Part (A), which is included in the kit is the TLS Conduit Adapter. The adapter fits into the bottom of the TLS Part (B).
3. Part (C), is a liquid tight 1/2" elbow. It is not included in the kit and must be supplied by the installer.
4. To assemble the adapter, thread Part (C) into Part (A), then insert Part (A) into the TLS body.
5. Final assembly is performed after the electrical wiring is connected to the switch.

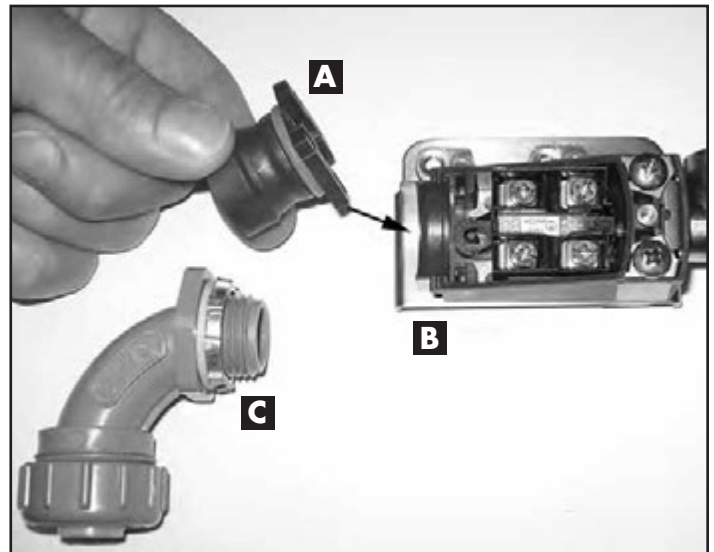

Fig. 6 -
Installing the TLS Conduit Adapter



WARNING:

Electrocution or serious injury may result when working on an energized circuit.

Disconnect power at the main breaker or service disconnect switch before working on the circuit.

Lock-out and tag the breaker to indicate that work is being performed on the circuit.

Section 5: Wiring Between the TLS and the Dishwasher.

1. Disconnect power to the dishwasher at the main service disconnect switch and tag the circuit to indicate that work is being performed on the circuit. All wiring and connections must be performed in accordance with local electrical codes or in the absence of local codes, the National Electrical Code.
2. Refer to Fig. 7, *TLS Conduit Routing*, below.
Flexible liquid tight conduit and two wire conductors must be run between the TLS and the Rinse Tank Terminal Block located in the rinse tank junction box on the front of the rinse tank. The heavy black lines represent the conduit routing between the TLS and rinse tank junction box.
3. Conduit, connectors, terminals and cable ties are not included in the kit.
4. The length of conduit and wire runs are determined by the installation dimensions.

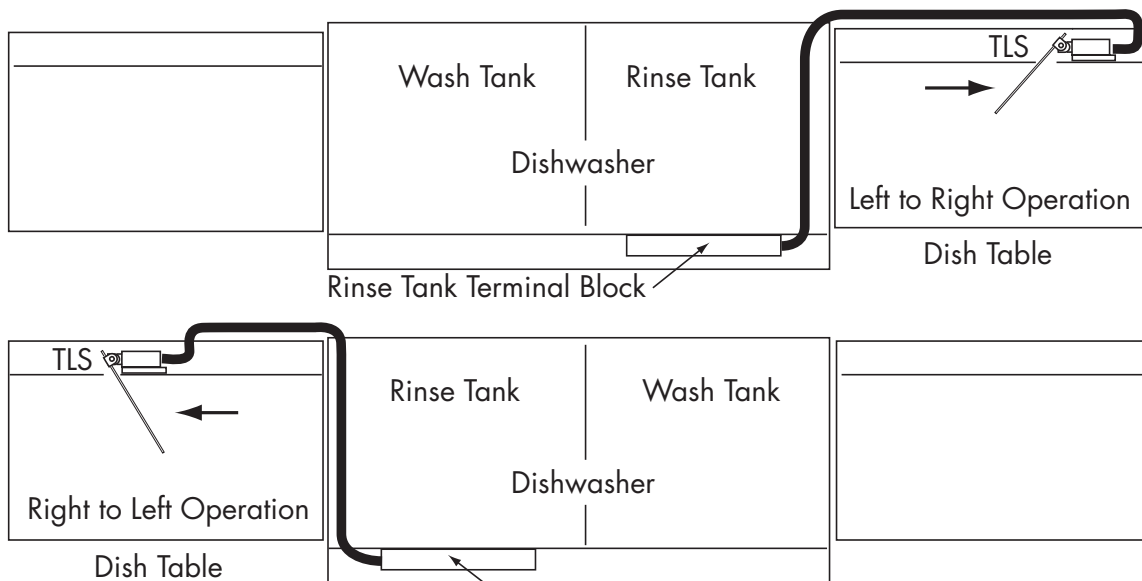

Fig. 7 -
TLS Conduit Routing
(Drawing Not to Scale)

Section 6: TLS and Dishwasher Electrical Connections

1. Open the dishwasher remote control cabinet.
2. Refer to Fig. 8 below. Locate the relay marked 5CR and remove the jumper wire connected to the relay socket.
3. Close the remote control cabinet.
4. Refer to Fig. 9 below. Remove the rinse tank front panel (A) and locate the junction box on the front of the tank.
5. Remove the junction box cover (B).

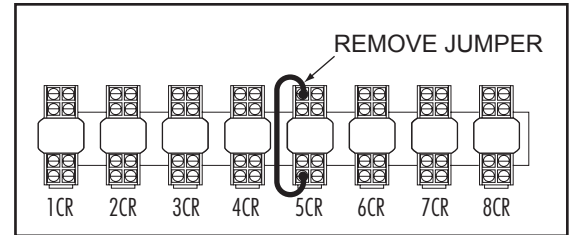

Fig. 8 -
Remove Jumper from 5CR relay located in the remote control cabinet.

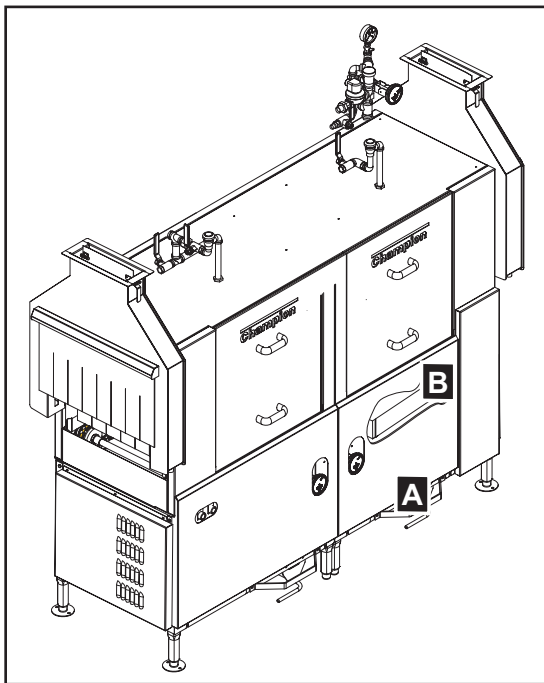

Fig. 9 -
Connect Wires Between TLS and the Terminal Block in the Control Cabinet.

6. Refer to Fig. 10 below. Connect one wire from TLS terminal 21 to Rinse Terminal Block terminal 30. It does not matter which wire. Connect the other wire from TLS terminal 22 to Rinse Terminal Block TB3 terminal 3B.
7. Close the junction box, replace the rinse tank front panel. See the next page for testing procedures.

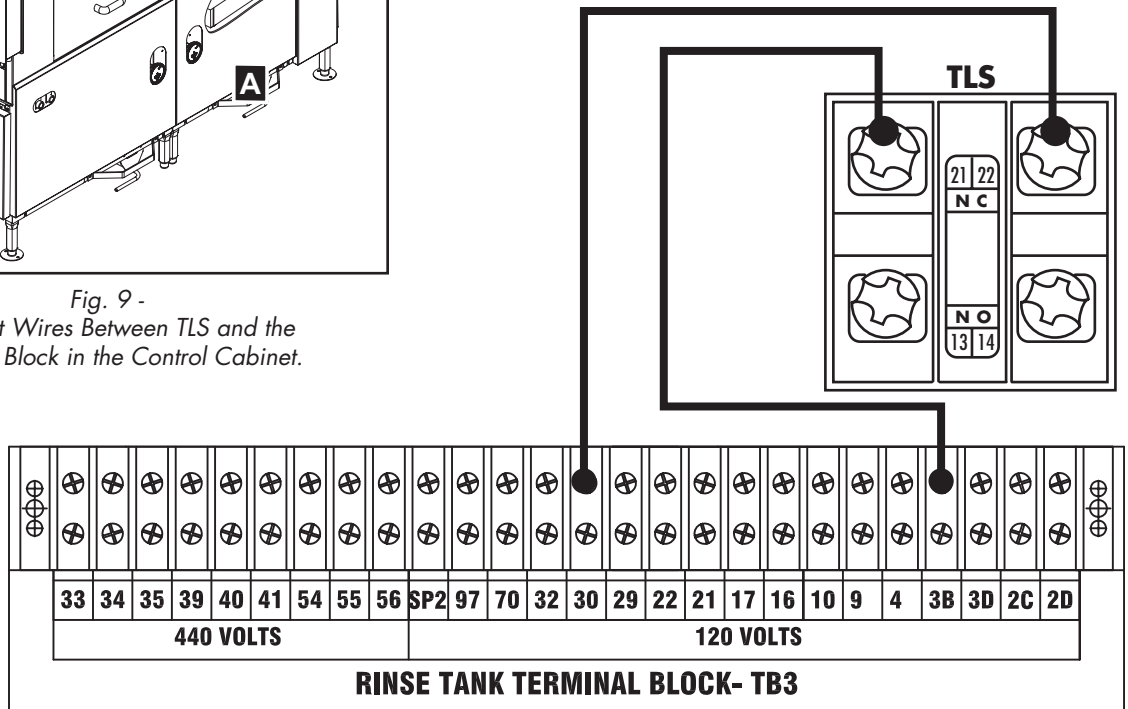
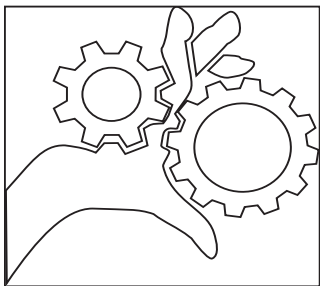

Fig. 10 -
Connect Wires between the TLS and the Rinse Tank Terminal Block.



WARNING:

Moving Conveyor Parts may cause INJURY OR DEATH. Keep hands and clothing clear of the conveyor when the conveyor is moving.

USE EXTREME CAUTION WHEN THE CONVEYOR IS MOVING.

Section 7: Testing the Table Limit Switch (TLS) Operation.

1. Reconnect power to the dishwasher at the main service disconnect switch.
2. Turn the dishwasher power switch ON. The dishwasher will fill with water.
3. Press the Start push button switch. The conveyor will run.
4. Insert a dish rack into the dishwasher.
5. When the first rack exits the machine, slide the rack towards the end of the dish table until it activates the TLS rod.
6. The dishwasher conveyor should stop BEFORE the TLS rod reaches the end of its travel in the 7/8" hole.
7. Readjust the TLS rod position until the switch operates as described step 6 above. The positioning is a trial-and-error adjustment.
8. Insert 4 dish racks into the dishwasher and check the operation of the TLS. The conveyor should stop whenever the TLS is activated. The dishwasher conveyor should restart when the TLS is deactivated.
9. If the TLS is adjusted correctly and the dishwasher conveyor does not stop, then check the TLS circuit, correct any problems and re-test the TLS operation.