

Champion[®]

The Dishwashing Machine Specialists

Project _____

Item No. _____

Quantity _____

STANDARD FEATURES

- Heavy-duty stainless steel construction
- Front-loading, split door design
- External rinse hose and spray gun
- Self-contained water heater
- Moisture resistant control gauges
- Recirculating wash water
- Adjustable wash and rinse cycles
- Easy to remove filter basket
- Digital control and information system
- Fresh water sanitizing rinse
- Versatile racking system
- User friendly, push-button operation

MODEL SD-20

Pot, Pan and Utensil Washer



MODEL SD-20 WASHER

OPTIONS

Tank Heat

Steam

Gas

Additional Lift Door and Split Door Models:

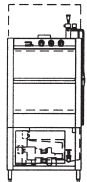

SD-10

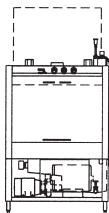

LD-20

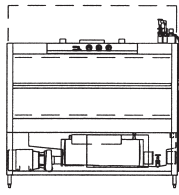

SD-36

Champion Industries, Inc.
 P. O. Box 4149, Winston-Salem, NC 27115
 Tel: 336/661-1556 Fax: 336/661-1979
 2674 N. Service Road,
 Jordan Station, Ontario, Canada L0R 1S0
 Tel: 800/263-5798 Fax: 905/562-4618

www.championindustries.com

MODEL SD-20

Pot, Pan and
Utensil Washer

Champion[®]

The Dishwashing Machine Specialists

Dimensions shown in inches

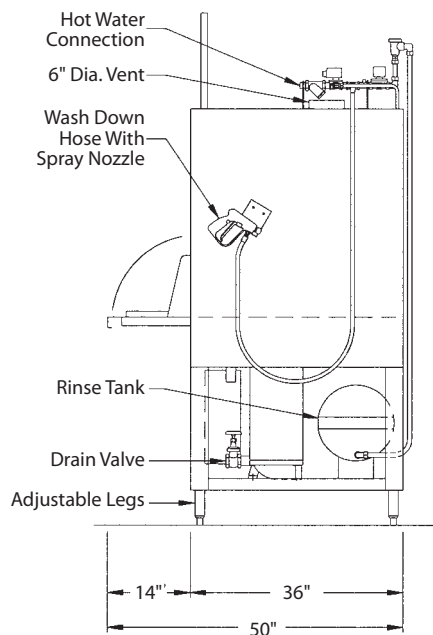
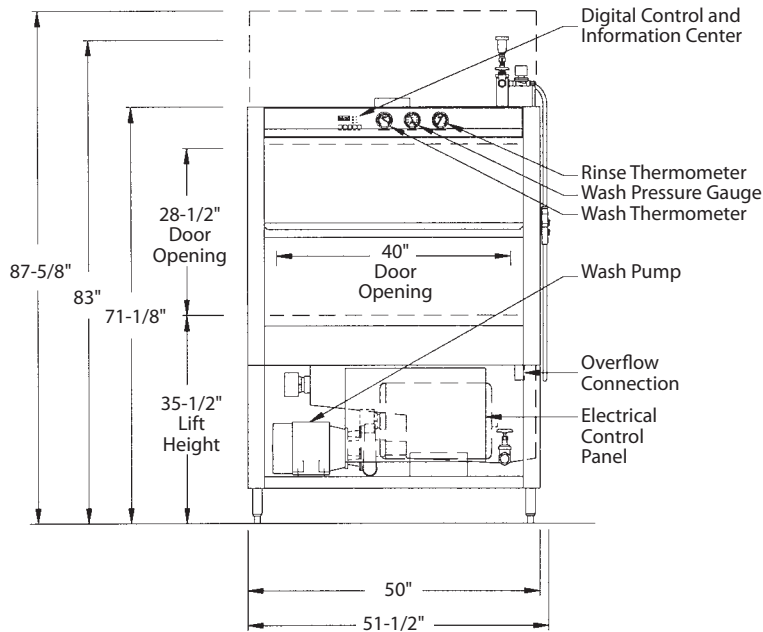

SPECIFICATIONS

Machine Construction

12, 14, & 16 gauge stainless steel. All seams Heliarc welded.

Door

Stainless steel split door design. The top half rises while the lower half folds down to provide a space saving drain table.

Spray Arm Assembly

Stainless steel spray arm assemblies, with stainless steel jets and quick-release mechanism for easy cleaning and reassembly.

Filter

Perforated, removable, stainless steel basket.

Water Pump

7-1/2 Hp, 208/240 or 440/480 volt, 1 phase or 3 phase, 60 cycle with output of 120 gallons per minute at 35 to 45 P.S.I.

Digital Control & Information Center

12 volt control circuit with push pad operation of "power on," "stop" and "short, medium or long wash cycles." A digital display indicates "time remaining" for each cycle. LED's indicate wash, rinse and unload functions. A buzzer is also included to provide an audible indication of time to unload. Pre-programmed circuit board allows the push pad to be used as a "diagnostic center" by displaying "error codes" for ease of troubleshooting.

Gauges

Special moisture resistant design, measures wash temperature, rinse temperature and wash jet pressure.

Wash Tank

Stainless steel with electric infrared, gas, steam or steam coil heating, thermostatically controlled, low-water protected, sloped to drain with a 36-gallon capacity (27 gallons if infrared gas heated)

Rinse Tank

Stainless steel with electric, infrared gas or steam coil heating to provide 180°F/190°F hot sanitizing rinse. Uses 5 gallons per 27-second cycle.

Racks

Stainless steel rod, built to match specific washing requirements.

Due to an ongoing value analysis program at Champion, specifications contained in this catalog are subject to change without notice.

Champion Industries, Inc., P. O. Box 4149, Winston-Salem, NC 27115 • 336/661-1556 • Fax: 336/661-1979 • www.championindustries.com
2674 N. Service Road, Jordan Station, Ontario, Canada L0R 1S0 • 800/263-5798 • Fax: 905/562-4618

Washer	Automatic washing machine designed to wash all pots, pans and utensils commonly used in baking and cooking operations.
Cabinet	50" wide x 36" deep x 71-1/8" high. Overall height with door open: 87-5/8". Door opening: 40" wide x 28-1/2" high. Constructed of 12, 14 & 16 gauge, type 304 #3 finish, stainless steel. All seams tig-welded, cleaned and polished.
Door	Front-loading, split door design for easy loading and unloading. The top half of the door system rises while the lower half folds down to create a space saving drain table. Door is interlocked with proximity switch to prevent machine operation while door is open. Door construction: 16 gauge, type 304 #3 finish, stainless steel.
Recirculating Wash Tank	Heated by 12kW total 208/240, 480 or optional 575 volt electric immersion heaters, thermostatically controlled 150°F wash temperature and low water protection system. 36 gallons (27 gallons if infrared heated), 14 gauge stainless steel, sloped to drain. Infrared gas and steam heating options available.
Wash Tank Filter	Perforated, stainless steel basket type, double filter system for increased effectiveness and easy cleaning without emptying wash tank.
Wash Tank Fill Valve	Size 1/2" brass material, solenoid type, automatic.
Wash Tank Drain Valve	Size 1-1/4" brass material, gate type for manual or electrically operated ball valve for automatic option.
Wash Pump	7-1/2 hp, 208/240, 480 or optional 575 volt, 3 phase, 60 cycle. Close coupled; 120 gallons per minute at 35 to 45 psi, mounted on 12 gauge stainless steel formed channel base.
Spray Arm Assemblies	Water driven, stainless steel spray arm assemblies, with stainless steeljets and quick-release mechanism for easy cleaning and reassembly.
Sanitizing Rinse Tank	Stainless steel, 10 gallon capacity, with 12kW total 208/240, 480 or optional 575 volt electric booster heater to provide 180°-190°F hot sanitizing rinse. Uses 5 gallons per 27 second cycle. Infrared gas and steam coil heating options available.
Rinse Supply Valve	Size 3/4" brass material, solenoid type, automatic.
Final Rinse Piping	Type 304 stainless steel tubing with brass compression fittings and brass or optional stainless steel full cone rinse jets.
Control & Information Center	12 volt control circuit with push pad operation of "Power On," "Stop" and "Short, Medium or Long Wash Cycles." A digital display indicates "Time Remaining" for each cycle. LED's indicated wash, rinse and unload functions. A buzzer is also included to provide an audible indication when the machine is ready to unload. A pre-programmed circuit board allows the push pad to be used as a "Diagnostic Center" by displaying "Error Codes" for ease of troubleshooting. Moisture resistant gauges measure Wash Temperature, Wash Pressure and Rinse Temperature.
External Rinse Hose	Externally mounted rinse hose with spray gun for easy cleaning and maintenance of machine.
Steam Exhaust Vent	Steam exhaust vent 6-3/4" I.D., consisting of 16 gauge rolled collar for PVC pipe connection bolted to the top of the machine. Machine pre-wired with control timer for the addition of a fan.



The Dishwashing Machine Specialists

SPECIFICATIONS MODEL SD-20 POT, PAN & UTENSIL WASHER

Optional Exhaust Fan

Draft inducer fan side mounted on exhaust duct to extract excess steam after final rinse cycle. 300 CFM @ .05" static pressure. 1/10 Hp, 110 volt motor, 1550 RPM.

Racks

Customized to hold your specific items. Standard bakery racks include utensil basket with (2) hold-down lids and (2) bun/sheet pans insert designed to hold (10) pans, constructed of stainless steel rod, mig-welded.

Connections

Water Inlet: 120°F, 3/4" NPT
Water Drain and Overflow: 1-1/4" NPT
Electrical: Two point connection (except 575 volt) through knock out on electrical enclosure.
Steam Heating Option: 1/2" NPT
Natural or Propane Gas Heating Option: 1/2" NPT

Weight

Crated: 1,100 lbs. Uncrated: 850 lbs.
NOTE: All weights are approximate. Weights will vary depending on the number of options included with the machine.

Services

120 Volt -1 phase, 5 running amps, 15 amp service, plus one of the following:

Elec. Spec.	Running Amps		
	Electric Wash Electric Booster	Steam Wash ¹ Steam Booster	Infrared Gas Wash ² Infrared Gas Booster
208 Volt 3 phase	86	19	19
240 Volt 3 phase	79	18	18
480 Volt 3 phase	40	9	9

¹ Steam Supply: Consumption: 95 lbs./hr. @ 15 psi minimum

² Gas Supply: Consumption: 90,000 BTU/hr. @ 1/2 lb. pressure maximum

Certifications

UL and UL Sanitation Listed (all). CUL Listed (electric and steam only).

