

# Champion®

The Dishwashing Machine Specialists

Project \_\_\_\_\_

Item No. \_\_\_\_\_

Quantity \_\_\_\_\_

## STANDARD FEATURES

- **ENERGY STAR® Qualified**
- *Exclusive DualRinse Technology*
- Dual-pawl cradle drive system
- One-piece cast stainless steel upper & lower spray arm assemblies
- Internal removable scrap basket and two-piece scrap screen
- Standard vertical opening accommodates 18" x 26" sheet pans
- Wide 26" leakproof doors, internally-fitted
- Anti-jam conveyor drive system
- Energy Sentinel (Idle pump shut-off)
- Convenient top-mounted controls
- Automatic tank fill
- Common utility connections
- Door safety switch
- Door activated drain closure
- Enclosure panels (front and sides)
- Splash shields
- Low-water tank heat protection
- Rinse-saver device
- Stainless steel heavy-gauge construction, including base and feet
- Electric tank heat
- Wash pump 2 Hp motor
- Stainless steel pump and impeller
- Single-point electrical connection

*The DualRinse feature offers the  
**Lowest Water/Utility/Chemical Consumption**  
while circulating a generous  
300+ gallons of water for  
**Consistently Good Results***

## DualRinse™ MODEL 44 DR

44" Single Tank  
High Temperature Rack  
Conveyor Dishwashing Machine with  
*Dual Stage Rinse*



Shown with Vent Cowl  
and Damper Option

## SPECIFIER STATEMENT

Specified unit will be Champion Model 44 DR high temperature dual rinse rack conveyor dishwashing machine. Constructed of Type 304 stainless steel and measuring 44" long with 20-3/4" vertical opening. Features top mounted control cabinet; upper and lower one-piece stainless steel spray arm assemblies, removable internal scrap basket with two-piece scrap screen. Large 26" wash door with front access and double-hook safety latch. Anti-jam conveyor drive system.

1 year parts and labor warranty.



**E-SERIES**

**DualRinse™**

Champion Industries, Inc.  
2674 N. Service Road,  
Jordan Station, Ontario, Canada L0R 1S0  
Tel: 905/562-4195 Fax: 905/562-4618

Champion Industries, Inc.  
P. O. Box 4149, Winston-Salem, NC 27115  
Tel: 336/661-1556 Fax: 336/661-1979  
[www.championindustries.com](http://www.championindustries.com)

# Champion<sup>®</sup>

The Dishwashing Machine Specialists

## MODEL 44 DR

44" Single Tank  
High Temperature Rack  
Conveyor Dishwashing Machine with  
**Dual Stage Rinse**

### EFFICIENT NEW SPRAY SYSTEM DESIGN

To make the E-Series more efficient and more forgiving we designed a new spray arm system that includes:

- Wall-of-water spray pattern via stainless steel fluted directional spray jets for quick and efficient washing
- Easily removable spray arm assembly for ease of cleaning
- Stainless steel pump housing and impeller
- Larger tanks hold more water for better washing results



Wall-of-Water Spray Pattern



One-Piece Cast Stainless Steel Spray Assembly

### INTEGRATED BOOSTER HEATER

As well as the E-Series performs, we created a way to make it perform even better. The electric booster heater may be optional, but it is an exceptional value — engineered within the E-Series footprint to offer a variety of advantages over other booster designs, such as:

- Inter-plumbed and inter-wired
- One control shuts off washer and booster
- 12 kW for 40°F rise
- 22 kW for 70°F rise
- Conductive heat transfer to wash tank
- Stainless steel booster heater lasts the life of the machine
- Integrated design saves floor space



Large Heating Element



Stainless Steel Built-in Nested Booster



Two-Piece Scrap Screen



Built-in Scrap Basket

### LESS IS MORE WITH CHAMPION'S DUAL RINSE MODEL 44 DR

Check our NSF listings and you'll see the 44 DR offers the lowest water consumption in its class with less than .54 US gallons per rack. Water consumption this low means energy savings too. Our 40°F rise booster only requires 12 kW and 70°F rise is only 22 kW.

What the numbers don't show you is the advantage that our Dual Rinse technology provides by making sure all wares are fully rinsed with more than 300 gallons per hour while actual fresh water consumption is only 112 gallons per hour.

# MODEL 44 DR

44" Single Tank  
High Temperature Rack  
Conveyor Dishwashing Machine with  
**Dual Stage Rinse**

**Champion**<sup>®</sup>  
The Dishwashing Machine Specialists

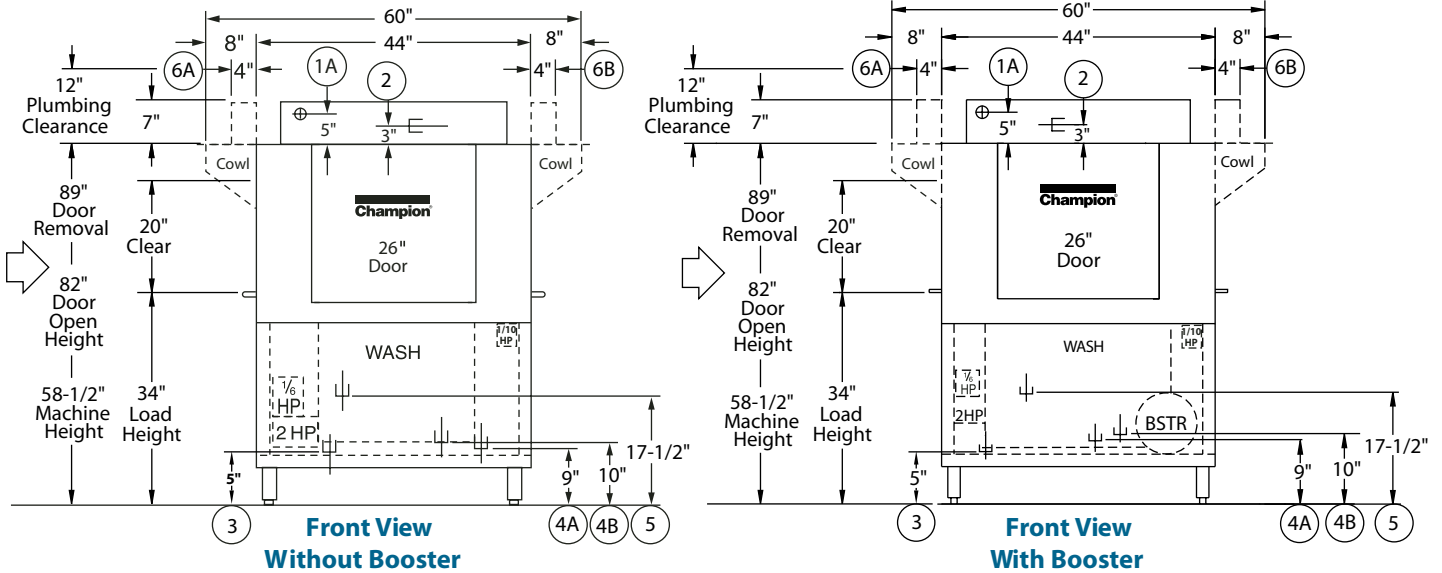

Left-to-Right Operation

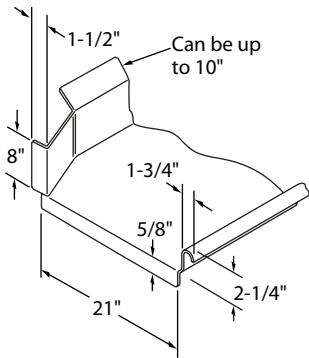

**Suggested Table Construction**

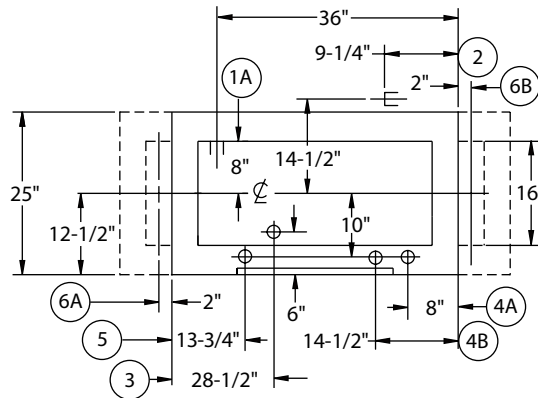

**Plan View**

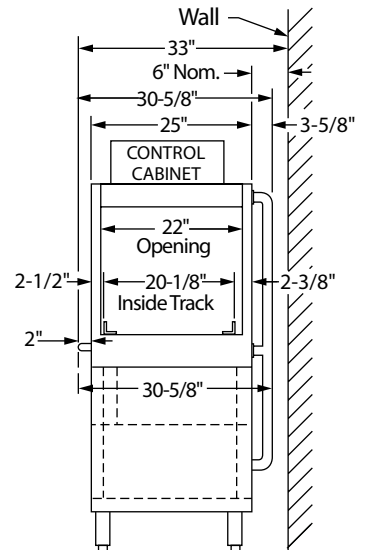

**End View**

# MODEL 44 DR

44" Single Tank  
High-Temperature Rack  
Conveyor Dishwashing Machine with  
**Dual Stage Rinse**

# Champion®

The Dishwashing Machine Specialists

Dimensions shown in inches

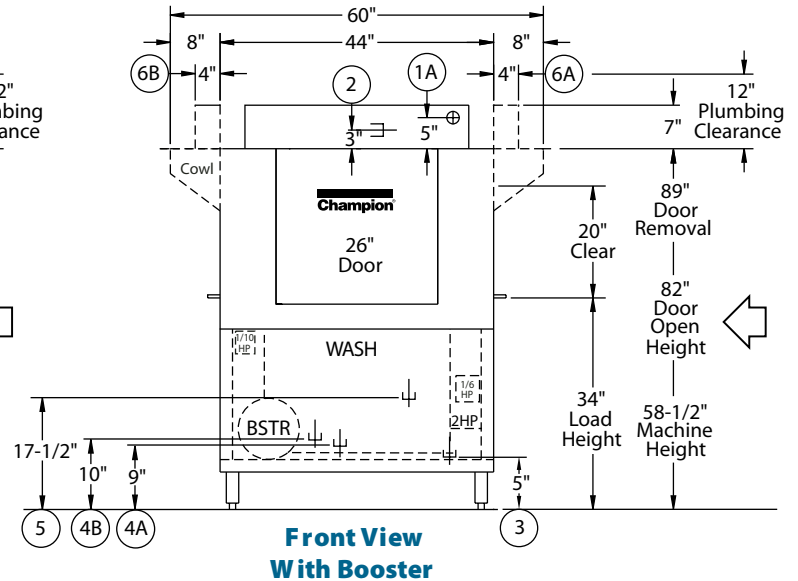
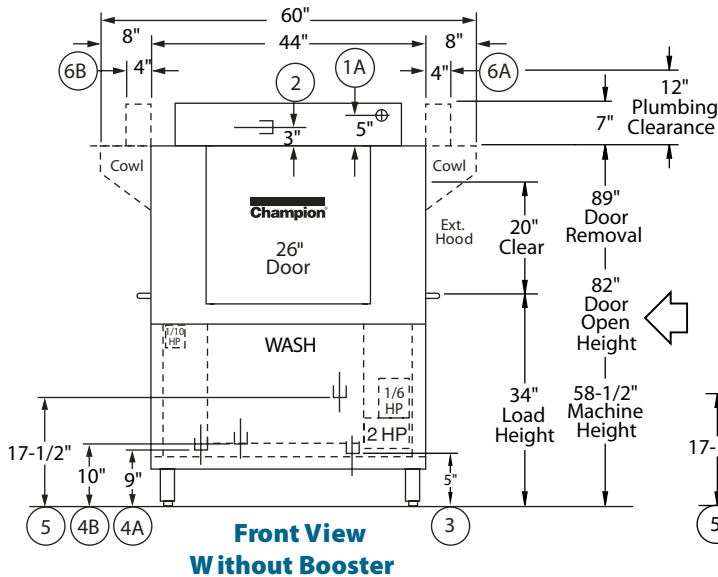

**Right-to-Left Operation**

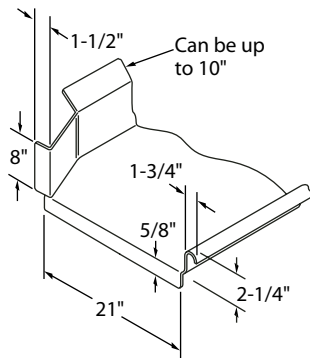

**Suggested Table Construction**

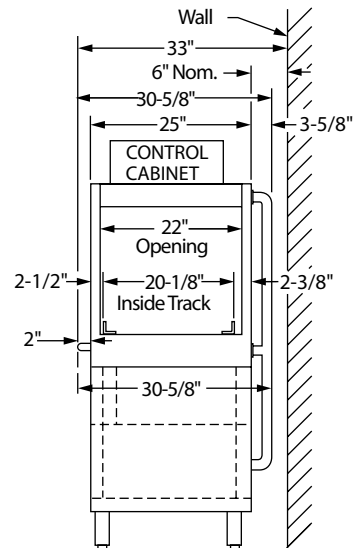
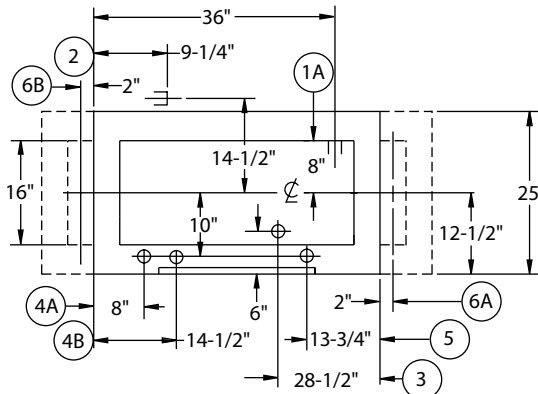

# MODEL 44 DR

44" Single Tank  
High Temperature Rack  
Conveyor Dishwashing Machine with  
**Dual Stage Rinse**

**Champion**<sup>®</sup>  
The Dishwashing Machine Specialists

Volume crated: **130 cu. ft.**  
Shipping weight crated: **600 lbs.**

Dimensions shown in inches

Utilities	
<b>1 Electrical Connection</b>	<b>A</b> Machine Only (see Table A) Machine & Booster (see Table B)
<b>2 Hot Water</b>	3/4" NPT 180°F/82°C min. hot water connection. (Machine without booster.) 3/4" NPT 140°F/60°C min. hot water connection. (40°F/34°C rise booster) 3/4" NPT 110°F/49°C min. hot water connection. (70°F/39°C rise booster) Flow pressure 20-22 psi.
<b>3 Drain</b>	1-1/2" NPT machine connection. Maximum flow 15 gpm.
<b>4 Steam</b>	<b>A</b> 3/4" NPT machine connection. Flow pressure 15-30 PSI. (Steam coil) <b>B</b> 3/4" NPT machine connection. Flow pressure 15-30 PSI. (Steam injector)
<b>5 Condensate</b> (no back pressure)	1/2" NPT machine return to boiler
<b>6 Vents</b>	<b>A</b> Load end: 200 CFM @ 1/4" S.P. <b>B</b> Unload end: 400 CFM @ 1/4" S.P. (With blower-dryer increase room ventilation by 600 CFM.)

**TABLE B - Machine & Booster Connection**

40°F/22°C Rise – 12 kW Machine and Electric built-in booster				
Elec. Specs.	Rated Amps	Minimum Supply Ckt. Conductor Ampacity	Maximum Overcurrent Protective Device	
208/60/1	169	225	225	
240/60/1	148	200	200	
208/60/3	104	150	150	
240/60/3	91	125	125	
480/60/3	46	60	60	
575/60/3	37	50	50	

70°F/39°C Rise – 22 kW Machine and Electric built-in booster				
Elec. Specs.	Rated Amps	Minimum Supply Ckt. Conductor Ampacity	Maximum Overcurrent Protective Device	
208/60/1	217	300	45	
240/60/1	190	250	250	
208/60/3	131	175	175	
240/60/3	115	150	150	
480/60/3	58	80	80	
575/60/3	47	60	60	

**TABLE A - Machine Connection**

Machine Only				Machine and steam built-in booster			
Elec. Specs.	Rated Amps	Minimum Supply Ckt. Conductor Ampacity	Maximum Overcurrent Protective Device	Elec. Specs.	Rated Amps	Minimum Supply Ckt. Conductor Ampacity	Maximum Overcurrent Protective Device
208/60/1	111	150	150	208/60/1	33	45	45
240/60/1	98	125	125	240/60/1	30	40	40
208/60/3	70	90	90	208/60/3	25	35	35
240/60/3	62	80	80	240/60/3	22	30	30
480/60/3	31	40	40	480/60/3	12	15	15
575/60/3	24	35	35	575/60/3	9	15	15

## SPECIFICATIONS

### Capacity

Racks per hr. (NSF rated)	208
Wash tank (US gal.)	21
Conveyor speed (ft./min.)	5.8

### Motor Horsepower

Drive	1/6
Wash 2	
Dual Rinse	1/10

### Heating

Wash Tank, electric (kW)	15
Dual Rinse Tank electric (kW)	3

Tank heat, steam (lbs./hr. required at 15 PSI flow pressure)	75
Electric booster (built-in) (kW supplied for 40°F rise)	12
Electric booster (kW supplied for 70°F rise)	22
Steam booster (lbs./hr. required for 40°F rise)	60
Steam booster (lbs./hr. required for 70°F rise)	106

### Water Consumption

US Gal. per hr. (max. use)	112
US Gal. per rack	.54

### Venting

Load end (minimum CFM)	200
Unload end (minimum CFM)	400

### Standard 20" x 20" rack complement

Peg	2
Flat	1

**Warning:** Plumbing and electrical connections should be made by qualified personnel who will observe all the applicable plumbing, sanitary, safety codes and the National Electrical Code.

**Note:** Water Hammer Arrestor (meeting ASSE-1010 standard or equivalent) to be supplied (by others) in common water supply line at service connection.

**Plumbing Notes:** Because of the variation in house-supplied steam and water pressures, steam and water pressure regulating valves (PRVs) may be needed. (Water PRV is standard on machines with booster.) The PRVs can either be purchased from Champion or obtained locally.

**Venting Notes:** Fabricated duct size: 3-7/8" x 15-7/8" (Outside dimensions)

Due to an ongoing value analysis program at Champion, specifications contained in this catalog are subject to change without notice.

Champion Industries, Inc., P. O. Box 4149, Winston-Salem, NC 27115 • 336/661-1556 • Fax: 336/661-1979 • www.championindustries.com  
2674 N. Service Road, Jordan Station, Ontario, Canada L0R 1S0 • 905/562-4195 • Fax: 905/562-4618

# MODEL 44 DR

44" Single Tank  
High Temperature Rack  
Conveyor Dishwashing Machine with  
**Dual Stage Rinse**

# Champion<sup>®</sup>

The Dishwashing Machine Specialists

## OPTIONS & ACCESSORIES

- Tank heat: choice of steam coil, steam injector, hot water coil
- Blower-dryer with 60" hood, table, legs and pawl bar assembly
- Booster Heaters  
(completely interplumbed, controls are interwired)
  - Steam: 40°F - 70°F rise
  - Electric: 12 kW (40°F rise) (built-in only)
  - Electric: 22 kW (70°F rise) (built-in only)
- Cantilever sideloader (with or without hood) for 90° load operation
- Extended pawl bar (extended drive unit) for use with load tabling
- 90° Motorized rack curve (unload)
- 180° Motorized rack curve (unload)
- Racks: peg or flat racks (specify type)
- Roller conveyor table (mobile or stationary)
- Steam pressure regulating valve (unmounted)
- Table limit switch, unmounted (recommended on all rack conveyor installations)
- Vent cowl, stainless steel with 7" stack and locking damper
- Extended vent hood, stainless steel with 7" stack and locking damper
- Water pressure regulating valve (unmounted) (standard with booster)
- Vent fan control
- Two-point electrical connection
- Water hammer kit
- Drain temp kit
- Vertical clearance through machine: 24" (instead of standard 20") for larger ware

**Model MRC 180**  
180° Motorized  
Rack Curve  
*(Must be ordered with Roller  
Conveyor Table)*



**Model MRC 90**  
90° Motorized  
Rack Curve  
*(Must be ordered with  
Roller Conveyor Table)*



**Cantilever  
Sideloader**  
*(No hood)*

**Model RCT 64  
or RCT 84**  
Roller  
Conveyor Table



Due to an ongoing value analysis program at Champion, specifications contained in this catalog are subject to change without notice.  
'USGBC' and related logo is a trademark owned by the U.S. Green Building Council and is used by permission.

Champion Industries, Inc., P. O. Box 4149, Winston-Salem, NC 27115 • 336/661-1556 • Fax: 336/661-1979 • www.championindustries.com  
2674 N. Service Road, Jordan Station, Ontario, Canada L0R 1S0 • 905/562-4195 • Fax: 905/562-4618