

Champion®

Operation and Cleaning Manual



EUCCW8
(shown with Optional Blower Dryer)

PRO SERIES Upright Conveyor Dishwashers

Models		
EUCC4	EUCC6	EUCC8
EUCCW4	EUCCW6	EUCCW8



championindustries.com

Issue Date: 11.30.20

Manual P/N 117171 rev. -

For machines beginning with S/N J20094452 and above

3765 Champion Boulevard
Winston-Salem, NC 27105
(336) 661-1556 Fax: (336) 661-1660
Toll-free: 1 (800) 858-4477

2674 N. Service Road, Jordan Station
Ontario, Canada L0R 1S0
(905) 562-4195 Fax: (905) 562-4618
Toll-free: 1 (800) 263-5798

Printed in the USA



National Service Department

In Canada:

Toll-free: (800) 263-5798
Tel: (905) 562-4195
Fax: (905) 562-4618
email: service@moyerdiebellimited.com

In the USA:

Toll-free: (800) 858-4477
Tel: (336) 661-1556
Fax: (336) 661-1660
email: service@championindustries.com

ATTENTION

The model no., serial no., voltage, Hz and phase are needed to identify your machine and to answer questions.

The machine data plate is located on the side of the top mounted control cabinet.

Please have this information ready if you call for service assistance.

Operation CODES

The Operation of the dishwasher must comply with all local electrical, plumbing, health and safety codes or in the absence of local codes, installed in accordance with the applicable requirements in the National Electrical Code, NFPA 70, Canadian Electrical Code (CEC), Part 1, CSA C22.1; and the Standard for Ventilation Control and Fire Protection of Commercial Cooking Operations, NFPA 96.



NOTE:

Only qualified personnel familiar with the Operation of food service equipment should attempt the Operation of this machine. Damage or problems associated with improper Operation will not be covered by the dishwasher limited warranty.



Two ways to REGISTER YOUR PRODUCT and ACTIVATE YOUR WARRANTY.

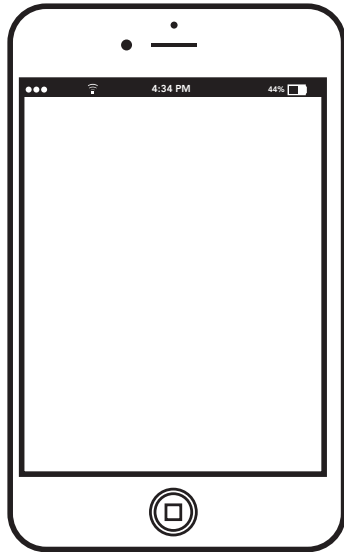

- Use your mobile phone or computer to go to our website at www.championindustries.com and register your product.

or

- Use the fax form on the next page.

PRODUCT REGISTRATION BY FAX

COMPLETE THIS FORM AND FAX TO:

(336) 661-1660 in the USA

1-(800) 204-0109 in Canada

PRODUCT REGISTRATION CARD

Model

Serial #

Date of Installation: ___/___/___

Company Name: _____

Address: _____
(Street) State/Province Zip/Postal Code

Telephone #: () _____ --- _____

Contact: _____

Installation Company: _____

Address: _____

Telephone #: _____

Contact: _____

FAILURE TO REGISTER YOUR PRODUCT MAY VOID YOUR WARRANTY

IMPORTANT IMPORTANT

Revision History

Specifications are subject to change based on continual product improvement. Dishwasher owners may request a manual by calling 1(800) 858-4477 in the USA and 1(800) 263-5798 in Canada.

Revision Date	Revised Pages	Serial Number Effectivity	Description
11.30.20	All	J20094452	Released First Edition

**This Page
Intentionally
Left Blank**

LIMITED WARRANTY

Champion Industries (herein referred to as "The Company"), 3765 Champion Blvd., Winston-Salem, North Carolina 27105, and 2674 N. Service Road, Jordan Station, Ontario, Canada, L0R 1S0, warrants machines, and parts, as set out below.

Warranty of Machines: The Company warrants all new machines of its manufacture bearing the name "Champion and installed within the United States and Canada to be free from defects in material and workmanship for a period of one (1) year after the date of Operation or fifteen (15) months after the date of shipment by The Company, whichever occurs first. [See below for special provisions relating to glasswashers.] Warranty registration must be submitted to The Company within ten (10) days after Operation either online at Champion Industries website (<http://www.championindustries.com/warranty-registration>) or by the fax form at the front of this manual. The Company will not assume any responsibility for extra costs for Operation in any area where there are jurisdictional problems with local trades or unions.

If a defect in workmanship or material is found to exist within the warranty period, The Company, at its election, will either repair or replace the defective part or accept return of the machine for full credit; provided; however, as to glasswashers, The Company's obligation with respect to labor associated with any repairs shall end (a) 120 days after shipment, or (b) 90 days after Operation, whichever occurs first. In the event that The Company elects to repair, the labor and work to be performed in connection with the warranty shall be done during regular working hours by a Champion authorized service technician. Defective parts become the property of The Company. Use of replacement parts not authorized by The Company will relieve The Company of all further liability in connection with its warranty. In no event will The Company's warranty obligation exceed The Company's charge for the machine. The following are not covered by The Company's warranty:

- a. Lighting of gas pilots or burners.
- b. Cleaning of gas lines.
- c. Replacement of fuses or resetting of overload breakers.
- d. Adjustment of thermostats.
- e. Adjustment of clutches.
- f. Opening or closing of utility supply valves or switching of electrical supply current.
- g. Cleaning of valves, strainers, screens, nozzles, or spray pipes.
- h. Performance of regular maintenance and cleaning as outlined in the operator's guide.
- i. Damages resulting from water conditions, accidents, alterations, improper use, abuse, tampering, improper Operation, or failure to follow maintenance and operation procedures.
- j. Wear on Pulper cutter blocks, pulse vanes, and auger brush.

Examples of the defects not covered by warranty include, but are not limited to: (1) Damage to the exterior or interior finish as a result of the above, (2) Use with utility service other than that designated on the rating plate, (3) Improper connection to utility service, (4) Inadequate or excessive water pressure, (5) Corrosion from chemicals dispensed in excess of recommended concentrations, (6) Failure of electrical components due to connection of chemical dispensing equipment installed by others, (7) Leaks or damage resulting from such leaks caused by the installer, including those at machine table connections or by connection of chemical dispensing equipment installed by others, (8) Failure to comply with local building codes, (9) Damage caused by labor dispute.

Warranty of Parts: The Company warrants all new machine parts produced or authorized by The Company to be free from defects in material and workmanship for a period of 90 days from date of invoice. If any defect in material and workmanship is found to exist within the warranty period The Company will replace the defective part without charge.

DISCLAIMER OF WARRANTIES AND LIMITATIONS OF LIABILITY. THE COMPANY'S WARRANTY IS ONLY TO THE EXTENT REFLECTED ABOVE. THE COMPANY'S MAKE NO OTHER WARRANTIES, EXPRESS OR IMPLIED, INCLUDING, BUT NOT LIMITED, TO ANY WARRANTY OF MERCHANTABILITY, OR FITNESS OF PURPOSE. THE COMPANY SHALL NOT BE LIABLE FOR INCIDENTAL OR CONSEQUENTIAL DAMAGES. THE REMEDIES SET OUT ABOVE ARE THE EXCLUSIVE REMEDIES FOR ANY DEFECTS FOUND TO EXIST IN THE COMPANY'S DISHWASHING MACHINES AND THE COMPANY'S PARTS, AND ALL OTHER REMEDIES ARE EXCLUDED, INCLUDING ANY LIABILITY FOR INCIDENTALS OR CONSEQUENTIAL DAMAGES.

The Company does not authorize any other person, including persons who deal in Champion dishwashing machines to change this warranty or create any other obligation in connection with Champion dishwashing machines.

TABLE OF CONTENTS

Revision History	i
Limited Warranty	xii
INITIAL SET-UP	1
Check the Machine.....	1
ASSEMBLING THE MACHINE	2
Check Conveyor Belt.....	2
Install Lower Spray Arms	3
Install Upper Spray Arms.....	4
Check Auxiliary Rinse Arms.....	5
Check Tank Interiors	5
Install Scrap Basket and Screens	6
Install Curtains	7
OPERATION.....	8
Loading and Unloading Wares.....	8
Tank Operating Temperature	9
Final Rinse Pressure Gauge	9
Control Cabinet.....	9
Operator Instructions	10
Faults	14
Machine Status Screen	20
Machine Setup and Test for Supervisors with Password 7777	23
CLEANING	25
Autoclean	25
At the End of the Day	28
Deliming	30

INITIAL SET-UP

Check the Machine

- Make sure all panels are properly installed.
- Remove protective plastic film from the machine exterior.
- Open doors and ensure they operate smoothly.
- Check the conveyor belt for tape debris. Check belt condition.
- Make sure the conveyor stop shelf moves freely back and forth.
- Check the interior of the machine and remove foreign material.
- Make sure the pump strainers, scrap screens, and scrap baskets are installed.
- Vent stack adjustment handles face the front of the machine.
- Open water supply and steam valves (if equipped). Check for leaks.
- Make sure the building drains are unobstructed.
- Make sure dishwasher area is clean, especially underneath the machine.



NOTE:

The dishwasher is equipped with automatic electric drain valves. The valves are open when power is off and closed when the power is on.

ASSEMBLING THE MACHINE

- Flight-type dishwashers come in a number of sizes and configurations. A basic design is shown below (Fig. 1).
- The machine is comprised of sections: Load and prewash tank, Wash/Rinse which includes the wash and power rinse tank, Auxiliary rinse tank which includes the final rinse piping, and the Unload section.
- The sections have a number of components that require installation before running the machine.

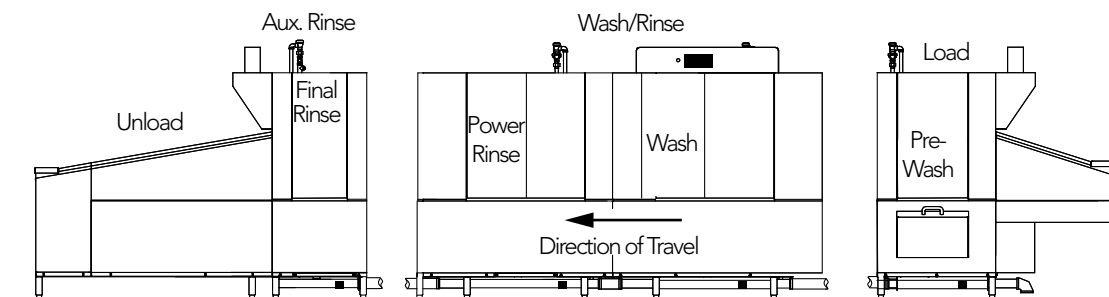

Fig. 1 -

ASSEMBLING THE MACHINE

- Follow the instructions below to check and assemble the machine as needed.

CHECK CONVEYOR BELT:

- Make sure the conveyor shut-off shelf moves freely and the photo-eyes are clear. (Fig. 2).

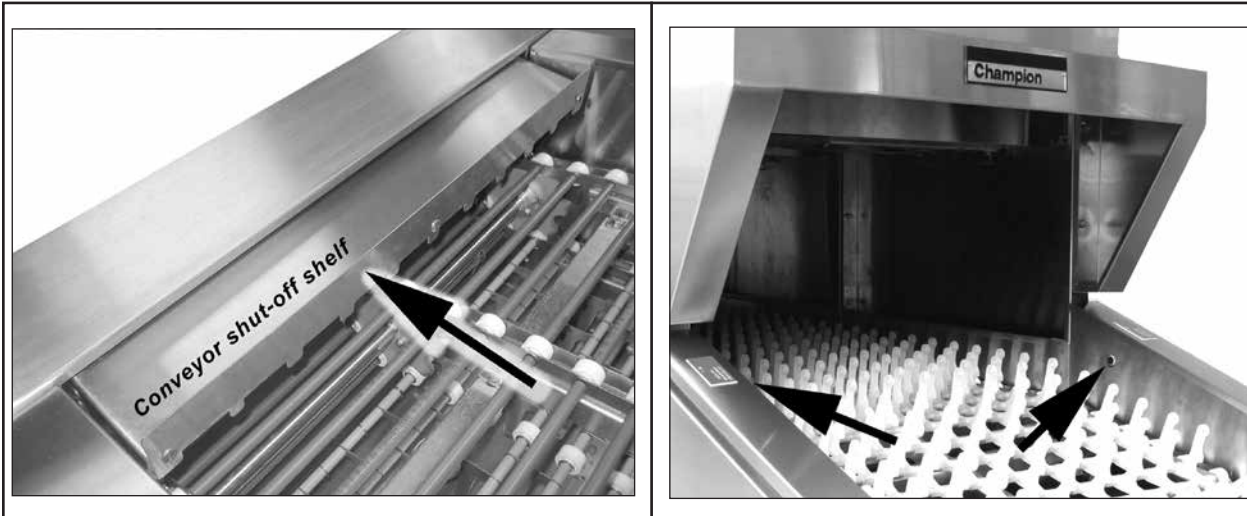

Fig. 2

OPEN DOORS

- Lift to open the right door first, then lift the second door to open (Fig. 3 and 4).



Fig. 3



Fig. 4



CAUTION:

Do not place hands above the top of the doors to close.



Fig. 5

INSTALL LOWER SPRAY ARMS

- Insert and slide the spray arm on its bracket until it engages the manifold at the back of the tank wall (Fig. 6).



Fig. 6

- Push the front of the spray arm down to lock the rod into the brackets.

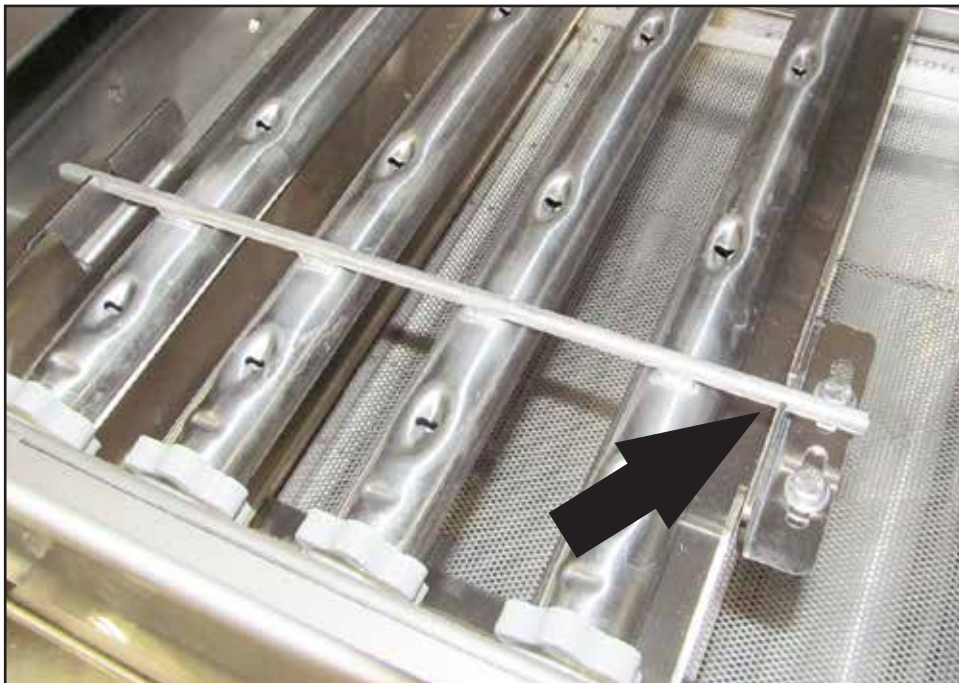

Fig. 7

INSTALL UPPER SPRAY ARMS

- Insert and slide the spray arm on its guides until it engages the manifold at the rear wall of the tank. (Fig. 8).
- Secure the arm in slots using the locking mechanisms. Firm upward pressure on the arm will lock it in place (Fig. 9).



Fig. 8

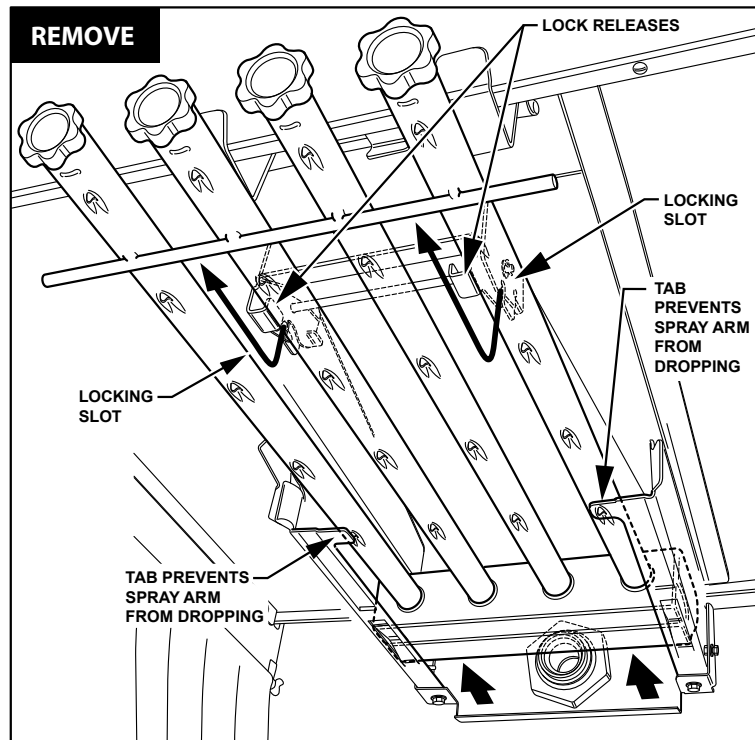
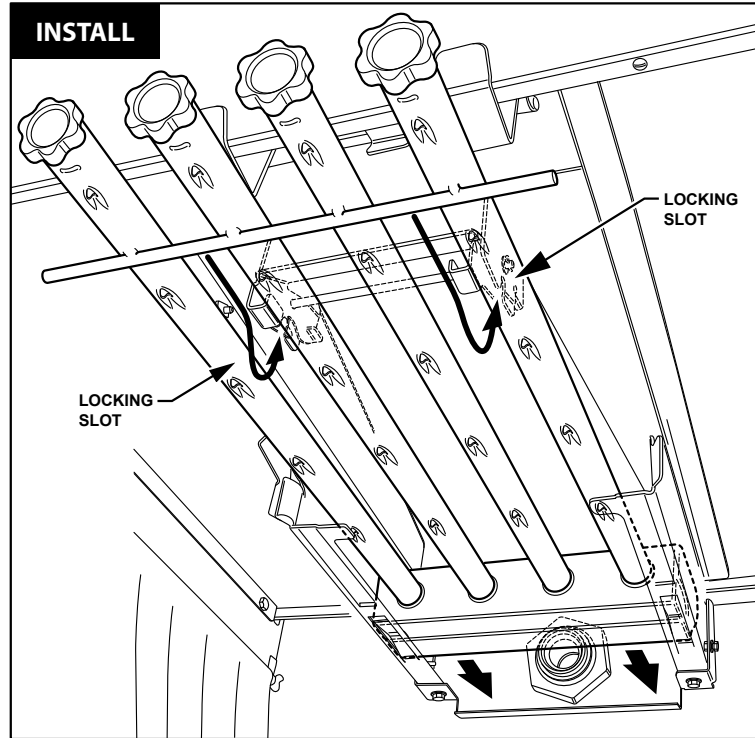

Fig. 9

CHECK AUXILIARY RINSE ARMS

- Make sure the removable upper and lower auxiliary rinse arms are securely in place (Fig. 10). The final rinse arms are not removable.



Fig. 10

CHECK TANK INTERIORS

- Remove the scrap screens if installed and check the bottom of the tanks for debris.
- Make sure the pump suction strainers are installed.
- Make sure the floats move freely.



Fig. 11

INSTALL SCRAP BASKET AND SCREENS

- Install the scrap basket in the prewash tank and other tanks if equipped. Make sure the scrap basket screen fits over the edge of the scrap basket (Fig. 12).

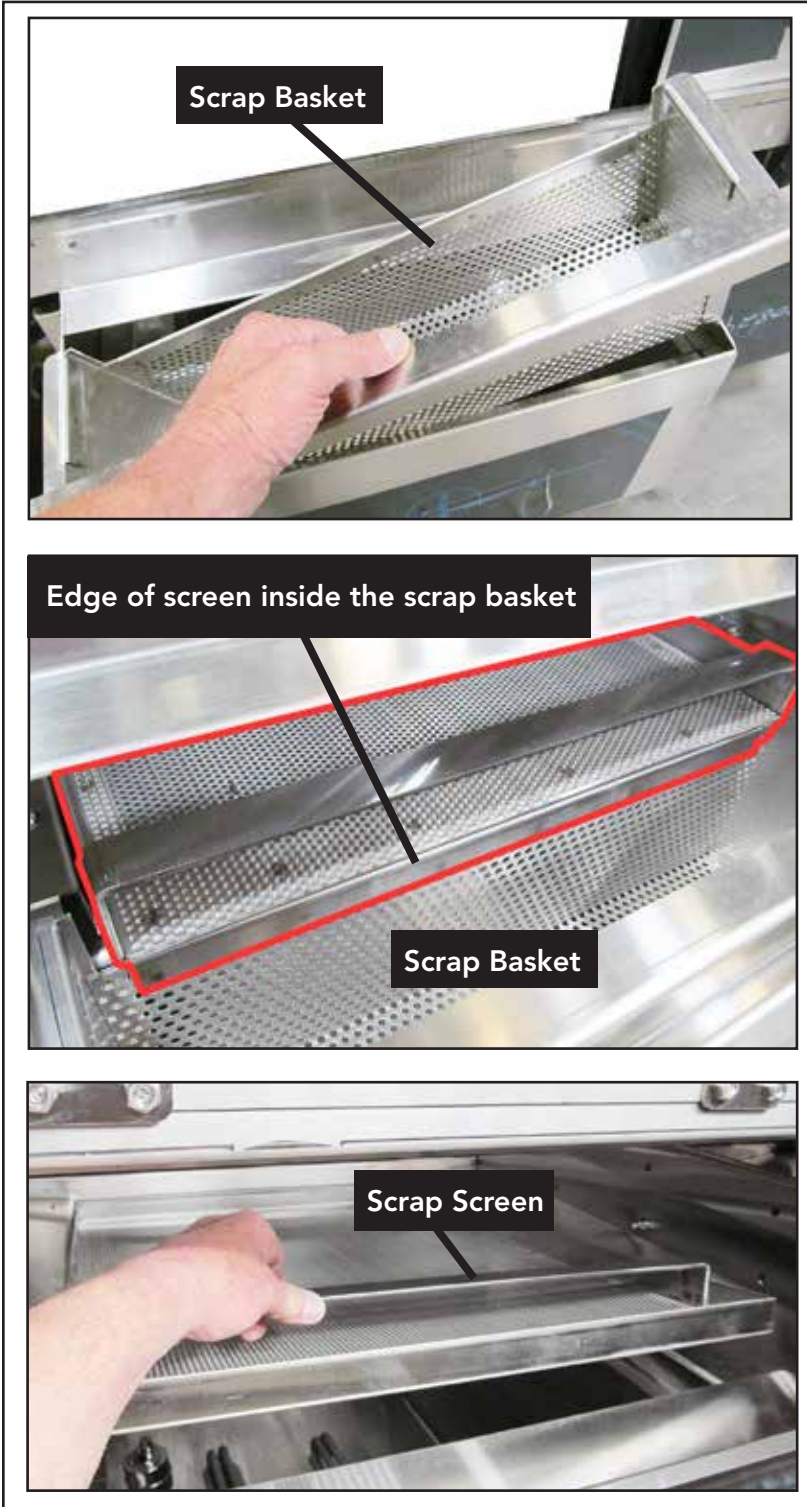

Fig. 12

INSTALL CURTAINS

- Labels applied to the machine identify the location and size for curtains (Fig. 13).
- Hang the curtain rods on the hooks inside the machine (Fig. 14a).
- Make sure the short flaps face the machine load end (Fig. 14b).

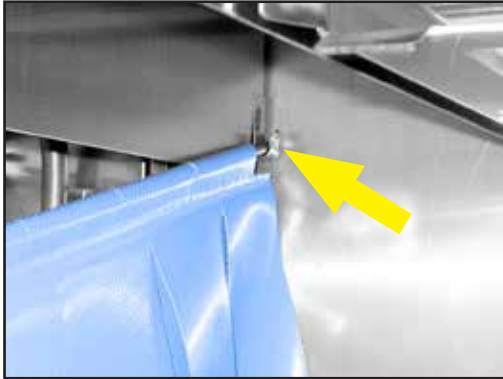

Fig. 14a



Fig. 14b



Fig. 13

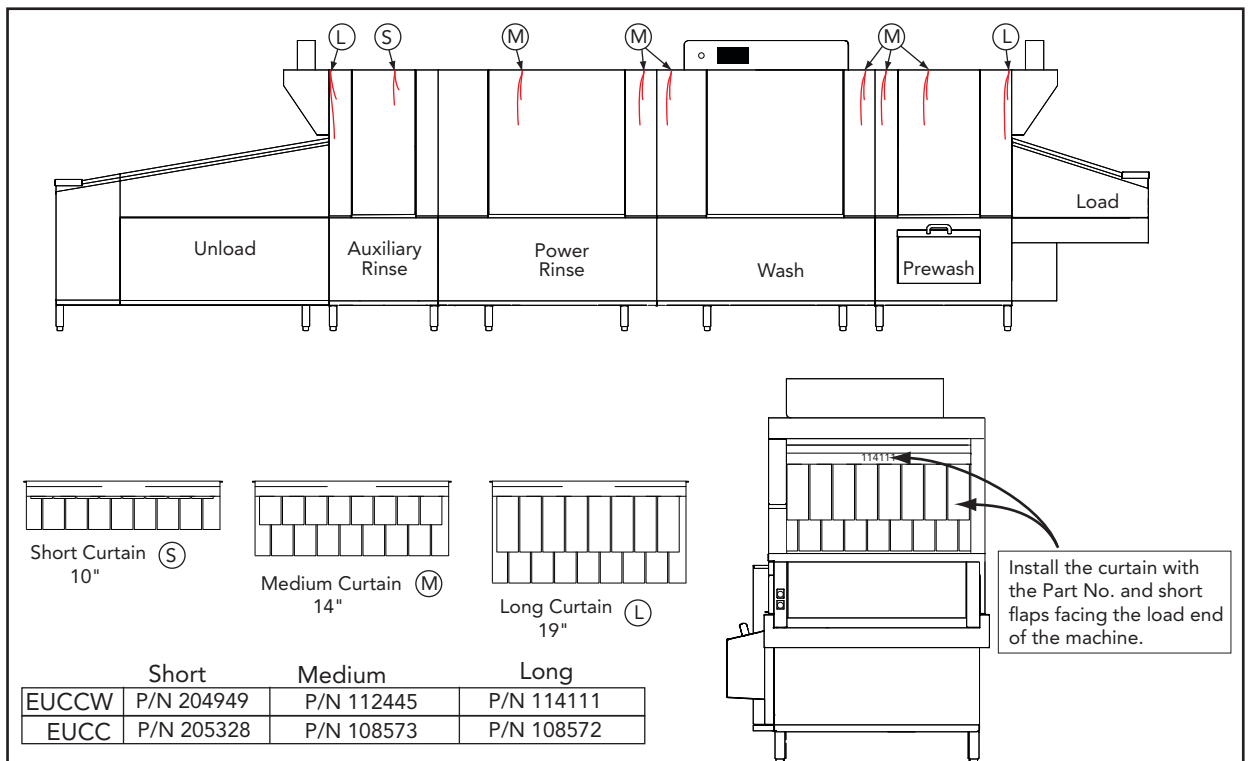
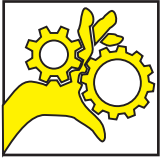

Fig. 15

LOADING WARES



CAUTION:

A moving conveyor belt can cause serious injury. Use extreme caution when loads wares on a moving conveyor belt. Stop the machine when clearing jams or cleaning the machine.



CAUTION: Make sure large wares will pass through the dishwasher without striking internal components such as spray arms, rinse piping or other components.

- Scrap and rinse large food particles, napkins, and other soils before loading.
- Pots, pans, and bake sheets may require manual scrubbing prior to loading.
- Never use steel wool to scrub wares. Doing so will cause rust in the machine.
- Place plates, saucers, and trays at a backward angle on the belts. Cups and bowls should be placed upside down.
- Bake sheets should be loaded longwise on the belt if possible. If not, then angle them perpendicularly on the belt. **NEVER** place a back sheet flat.
- Place pots and pans upside down.
- Silverware and utensils must be placed in a single layer in a dish rack and the dish rack should then be placed on the belt.



CAUTION: The dishwasher is designed to wash dishes and other wares. **NEVER** place floor mats, mops, scrub pads, or any other foreign object into the machine.

UNLOADING WARES

- Remove wares from the belt as they exit the machine. Be careful, dishes may be hot.
- The conveyor stops if wares push the shut-off shelf to the off position. Pumps still run.
- - a. Wares contact the shut-off shelf.
 - b. Shut-off shelf moves to the off position. Remove wares.
 - c. Move the shut-off shelf back to the on position.
 - d. Conveyor will resume operation.



Fig. 16

TANK OPERATING TEMPERATURES

The chart below illustrates the necessary tank temperature ranges for proper cleaning and sanitization. Typical incoming water temperatures are between 110°F/43.3°C and 140°F/60°C.

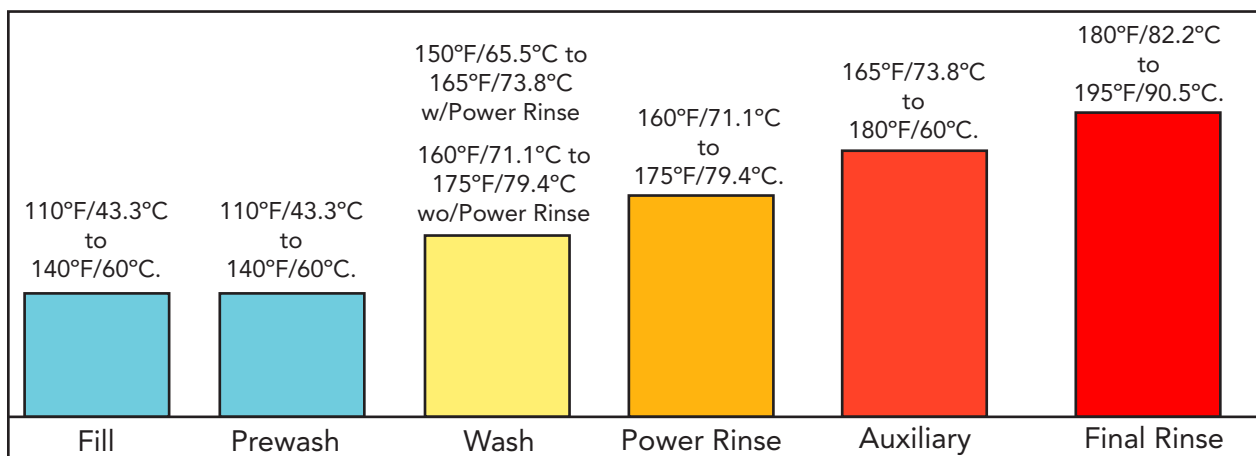

Chart 1

FINAL RINSE PRESSURE GAUGE

The final rinse pressure gauge is located at the top of the dishwasher above the final rinse section of the machine. The gauge should read a flowing pressure of 10 or 20 PSI during the final rinse.



Fig. 17

CONTROL CABINET

The control cabinet has operator controls on the front of the control cabinet.

- a) A green ON/OFF push button switch.
- b) AN HMI digital touchscreen display to display machine operation and provide user input.

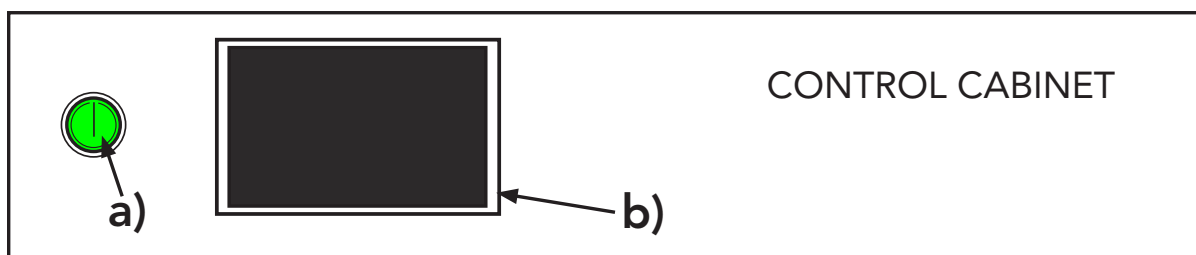

Fig. 18

HMI controls continued on next page.

OPERATOR INSTRUCTIONS



NOTE:

The following instructions apply to all models. Your machine may be configured differently; however, the operation of the machine will be the same.

DIGITAL TOUCHSCREEN DISPLAY, (HMI)

The HMI touchscreen display allows the operator to push to:

- Control the operation of the machine with touchscreen buttons.
- Monitor machine operation and fault conditions.
- Troubleshoot and resolve machine faults.
- Perform maintenance functions such as Delime and AutoClean.

INITIAL START

1. Turn on power and water to the machine.
2. Press the green on/off push button. The button illuminates (Fig. 18, page 9).
3. The 'Booting' screen appears indicating the program is loading (Fig. 19).

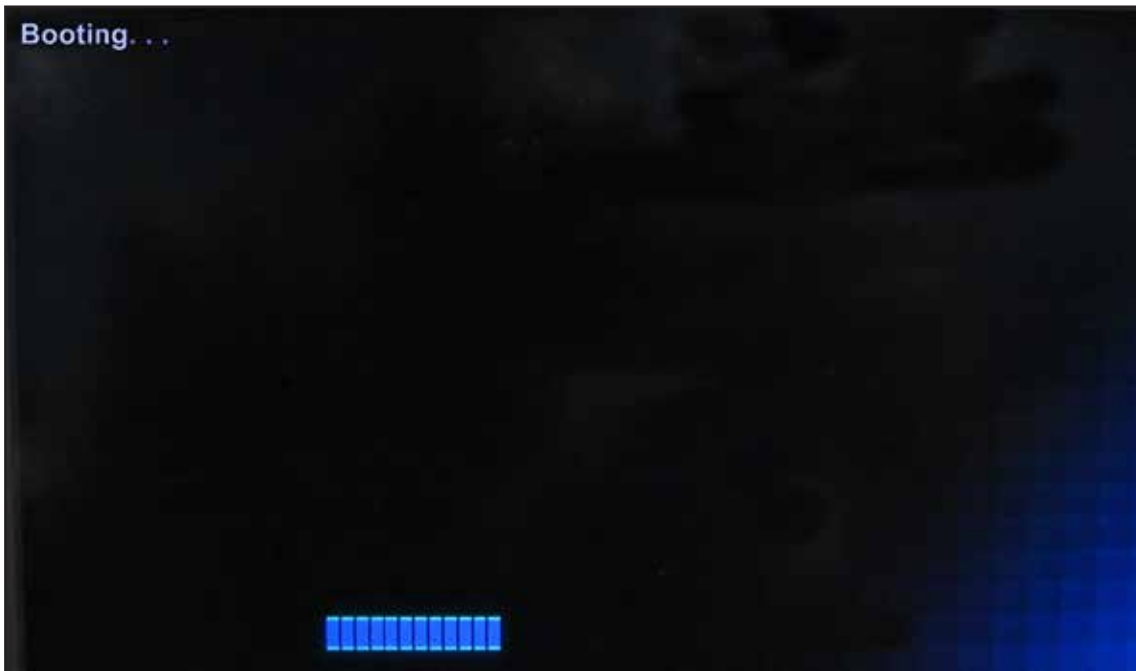

Fig. 19 - Program boot screen

4. The initial 'HOME' screen appears showing the machine tanks, data fields, and, touchscreen "action" buttons (Fig. 20). Data fields and buttons change as the machine operates.

MACHINE FILLING

- The "MACHINE FILLING" is the first operation screen, (Fig. 20). Refer to the screen icon legend for the descriptions and functions of the screen icons.



Fig. 20 - MACHINE FILLING.

SCREEN ICON LEGEND

Icon	Description	Function
<p>1</p>	<p>Status Bar - located at top of screen. Color changes with function.</p>	<p>Blue = "Machine Filling". Black = "Press Start to Run" or screen names. Green = "Machine Running". Yellow = Critical/Warning Fault an operator can resolve. Red = Fatal fault, operator may bypass or it will need a service agent to resolve.</p>
<p>2</p>	<p>Machine Sections - located in the center of the 'Home' screen. The name of the section appears above the icon.</p>	<p>Displays operation details of the section including: current tank temperature, tank water level, filling or draining info, heater status, pump status, and fault indicator.</p>
<p>3</p>	<p>FILLING - appears above the tank.</p>	<p>FILLING - indicates the fill valve for the tank is open and the tank is filling with water.</p>
<p>4</p>	<p>Tank Water Temperature - located at top of section field. Displays current temperature.</p>	<p>Displays current tank water temperature for each section and the final rinse temperature. Can be set to °F or °C. The final rinse temperature only displays when it is on.</p>
<p>5</p>	<p>Final Rinse Spray - located in final rinse section at the end of the machine section display.</p>	<p>Indicates the final rinse spray is off. FINAL RINSE OFF appears above the icon; The temperature field is blank. The spray icon shows the final rinse is on. The temperature field displays above the icon.</p>

Table 1 - Screen icon legend

PRESS START TO RUN

6. PRESS START TO RUN appears once the tanks are full. Press the START button to begin operation. The conveyor begins to run and pumps will start when dishes enter the machine.



Fig. 21 - PRESS START TO RUN

SCREEN ICON LEGEND (continued)







Icon	Description	Function
6 Start 	START Button - Push to start machine conveyor. Located in the bottom left corner of the screen.	The START button appears once the tanks are full of water. Press the button and the conveyor will begin to run.
(Empty)  (Lower Float made)  7 (Full) Upper Float made) 	Tanks with Water Levels - located at the bottom of the Machine Sections (see #2 above). The tanks are shown as white cyclinders. The water levels are shown in blue.	Blue water levels blink on and off as the tank fills or drains. The displays indirectly show that fill valves, floats, and tank heaters in correlation with other icons are performing properly. In addition, the water level data indirectly helps to evaluate a number of fault conditions.
8 Pump Off 	Pump Icon - is located next to the water tank icon.	The empty pump icon indicates the wash pump is not running.
9 Pump On 	Pump Icon - is located next to the water tank icon.	The pump vanes icon indicates the wash pump is running.

Table 1 - Screen icon legend (continued)

MACHINE RUNNING

7. MACHINE RUNNING appears once the start button is pressed. The conveyor begins to run and pumps will start when dishes enter the machine and break the photoeye beam.
8. The machine continues to run until the Stop button is pressed, the power switch is pressed or the machine enters a fault condition.



Fig. 22 - MACHINE RUNNING

SCREEN ICON LEGEND (continued)

Icon	Description	Function
10	Conveyor Icon - Located at the bottom of the screen.	The blue conveyor icon appears when the green start button is pressed. Blue means the conveyor is running normally.
11	STOP Button - Located in the bottom left corner of the screen.	Stops the conveyor and pumps until Green start button is pressed.
12 Heater ON Heater OFF	Tank Heater Status Icons - Located above the pump icon (see #6).	The tank heater icon will come on (RED) when the lower float is satisfied and remain on until the tank reaches its set point. The tank icon turns (GRAY).
13	"GEARS" located next to Green Start and Red Stop buttons.	The Gears button accesses status screens. These screens are used by the operator and service agent to resolve a fault event.
14	"DELIME" located next to Green Start/Red Stop buttons.	The delime icon appears when the preset operating time is reached. Press the button and follow delimiting instructions shown.
15	"PM" for Preventive Maintenance "TOOLS" icon is located next to Green Start/Red Stop buttons.	The PM icon appears when the preset operating time is reached. If DELIME is shown the "TOOLS" icon appears after the delime procedure is complete.

Table 1 - Screen icon legend (continued)

FAULTS

Faults describe conditions where the machine may experience problems. Many problems can be handled by the operator using the built-in troubleshooting guides in the system. A service repair number is always provided for the operator to call for service support. There are three basic classes of faults. They are listed below:

- FATAL faults stop machine operation until the problem is fixed.
- CRITICAL or warning faults can be resolved by the operator.
- Alerts indicating that a Deliming or Preventive Maintenance function is due.

FATAL FAULT EXAMPLE

"DOOR OPEN" is an example of a FATAL FAULT. It is a fatal fault because the machine will not run until the fault is fixed.

Screen 1: A red bar appears at the top of the Main screen with "DOOR OPEN" in the status bar. The green start button is gone. A red door has appeared. The operator is prompted to touch the red door icon.



Screen 2: The section where the problem occurs is highlighted in red. Press the "Tools" icon to troubleshoot or the phone to get the service agent phone number. Note the number "BD-8". The service agent may ask for this number to help troubleshoot.



Screen 3: Shows the troubleshooting procedure. Following the steps on this screen will help the operator to resolve the fault.



Screen 4: Shows the Main screen after a successful correction to the Door Open fault. The door icon has disappeared, the operator has pushed the green start button to restart the machine, and "MACHINE RUNNING" now appears in the green status bar at the top of the Main screen.



NOTE: Many fault resolutions follow the same pattern as above. In each case, the operator has the option to press the Phone icon to call a service agent.

CRITICAL FAULT EXAMPLE

Critical Faults can be acknowledged by the operator in a troubleshooting screen. This allows the machine to operate with a error condition.

"MACHINE FILL TIME EXCEEDED" is a critical fault.

Screen 1: The top status bar is red with the name of the fault in it. In addition, a blinking yellow triangle appears in the wash section telling the operator this is the location of the fault. The green start button has disappeared and the wash heater icon is grey.

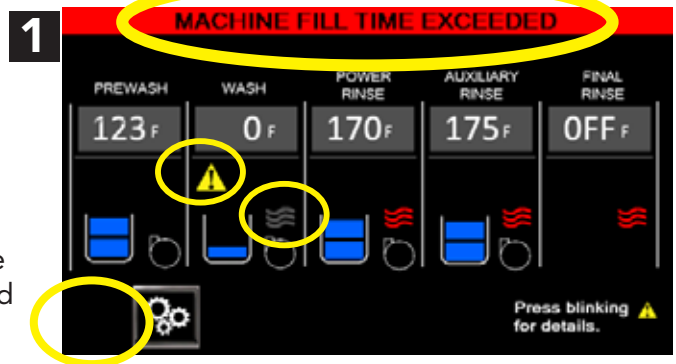

Screen 2: The operator may be able to resolve this fault using the built-in troubleshooting menus. Note the prompt in the lower right corner and the blinking yellow triangle in the wash section. Press the yellow triangle to access troubleshooting.

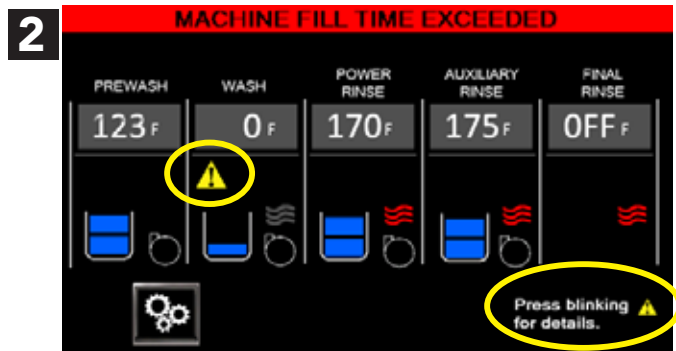

Screen 3: There are more troubleshooting screens in addition to Screen 3 but the process is the same. Follow the instructions provided and press the acknowledge icon to return the machine to operation. Press the Phone Icon if a service agent is required. Note the code W1-9-2 in the upper right corner of the screen. The service agent may request the code.

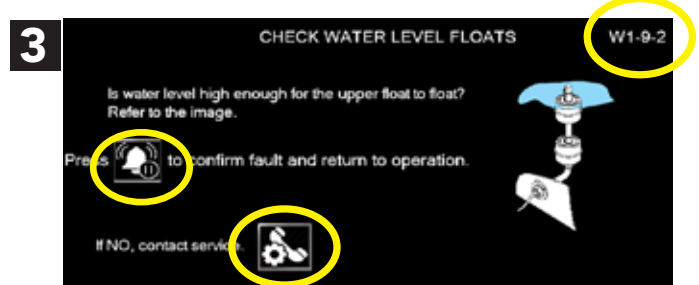

← Acknowledge Icon



← Call Service Icon

Screen 4: With the fault acknowledged, the fault status bar has turned yellow, PRESS START TO RUN has appeared and the green run button has returned. The yellow triangle is still visible to remind the operator the machine is operating with a fault. The operator should call service and have this problem fixed as soon as possible.



Faults

FAULTS (continued)

PHOTOEYE FAULT BYPASS

The photoeye located at the load end of the machine detects dishes as they enter the machine.

Scenario 1: PHOTOEYE BLOCKED ON POWER UP: If the photoeye is blocked when the green power button is pressed, the machine detects and displays the photoeye fault. The fault may be bypassed using the troubleshooting menu. The photoeyes should be cleaned and any dishes removed that may be blocking the beam. Turning the power off and immediately back on may reset the fault alarm.

Screen 1: PHOTOEYE FAULT appears in the red status bar at the top of the screen. The green start button does not appear. The yellow triangle appears at the bottom of the screen. Press the yellow triangle to access the troubleshooting menu.

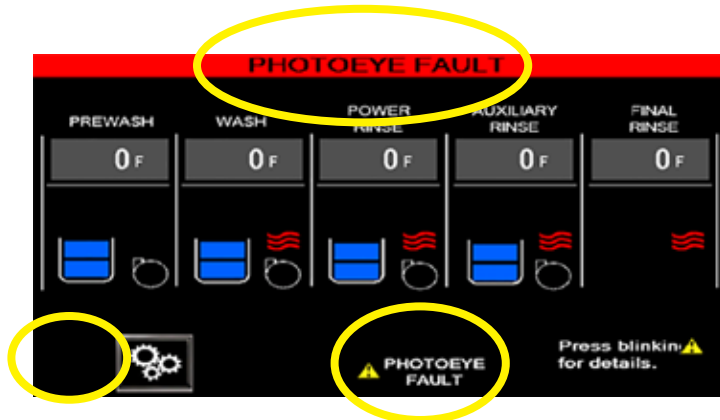

Screen 2: PHOTOEYE FAULT changes to a yellow status bar. A blinking red dot identifies the location of the fault. Follow the troubleshooting instructions and acknowledge the fault to restore machine operation.

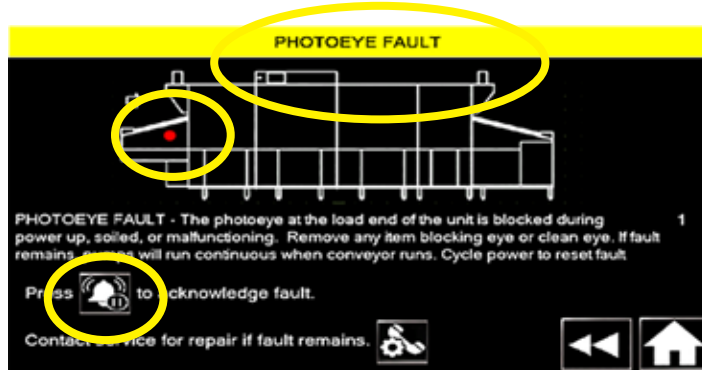

Screen 3: PRESS START TO RUN appears with PHOTOEYE BYPASSED in the yellow lower status bar indicating the machine will run with a photoeye fault. Photoeye Fault with a yellow triangle is displayed at the bottom of the screen to alert the machine is running with a fault.

Note:

The pumps will run when the conveyor is started and stop when the conveyor stops

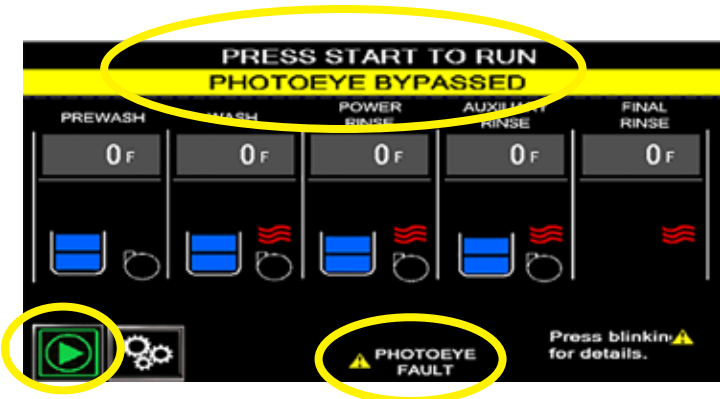

Scenario 2: PHOTOEYE FAILS WHILE MACHINE IS RUNNING

1

Screen 1: PHOTOEYE FAULT appears in the red status bar to the top of the screen. The green start button does not appear. The yellow triangle appears at the bottom of the screen.

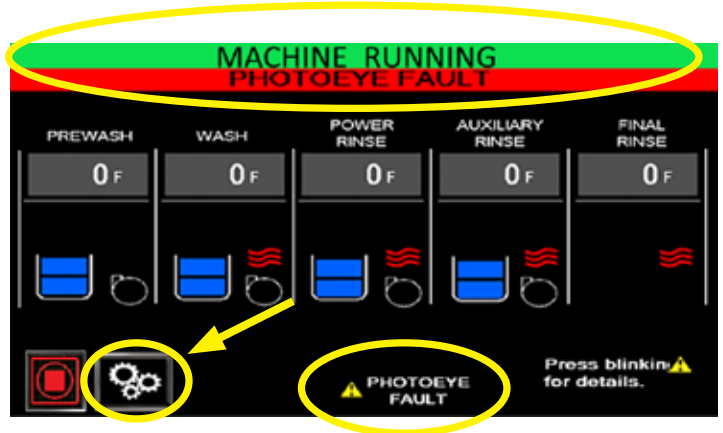

Screen 2: MACHINE STATUS SCREEN
Press the "Gears" button at the bottom of the screen to access the Machine Status Screen.



← Gears accesses Machine Status Screen

2

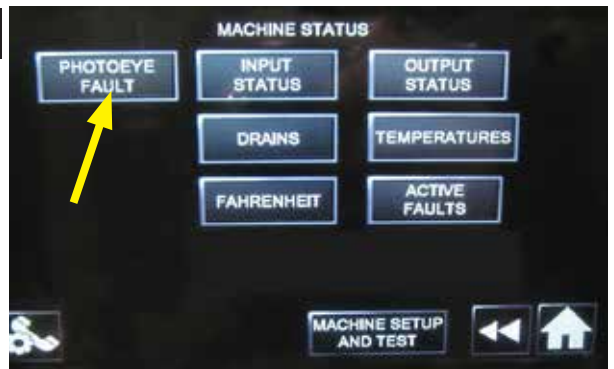

Screen: 3 PHOTOEYE FAULT BYPASSED
Press the "PHOTOEYE FAULT" button to bypass the fault. Photoeye fault changes to PHOTOEYE BYPASSED. Press the HOME button to return to the MAIN screen and resume operation under a fault condition.

3

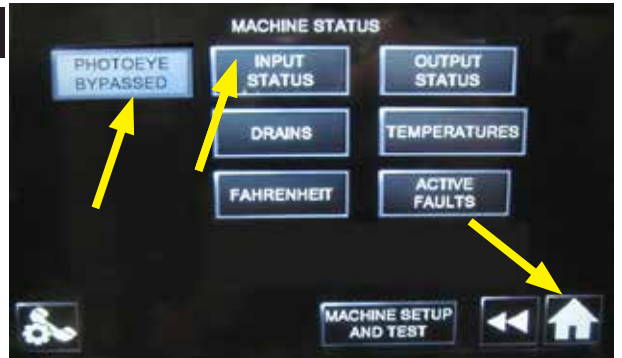

Screen:4
PHOTOEYE BYPASSED
The status bar displays "Machine Running" in a green bar and "Photoeye Bypassed" in a yellow bar.

4

The conveyor, pumps, and final rinse will run constantly until the machine is stopped.



FAULT STATUS BARS

Common status bars that appear at the top of the MAIN screen are shown in Table 1.

DOOR OPEN	CONVEYOR JAMMED	FILL TIME EXCEEDED
CONVEYOR FULL	DRAIN TIME EXCEEDED	WATER LEVEL FLOAT FAULT
THERMISTOR FAULT	PHOTOEYE FAULT	
PHOTOEYE BYPASSED	TANK LEAKING	
HEATER FAULT	TEMP CHECK	

Table 2 - Fault status bars

FAULT ICONS

Refer to the Fault Icon Legend on the next two pages for the descriptions of the icons.

FAULT ICON LEGEND







Icon	Description	Function
1 	Blinking Triangle - Icon appears when fault has occurred.	Icon blinks in the area of fault such as, in a tank icon, or the conveyor belt. PRESS BLINKING FOR DETAILS prompts the operator to press the fault alarm icon to enable the troubleshooting instructions.
2 	Gears - Appears in the lower left corner of the HMI screen. The icon blinks when there is a machine fault, solid when machine operation is normal.	Blinking gears icon prompts the operator to press the icon to enable instructions. Pressing the icon may also be used to access the Machine Status screen for fault info.
3 	Acknowledge Fault - located in the fault menus.	Used for Critical faults that do not prevent machine operation. Press the button to confirm the fault has occurred. Home screen will reappear. Resume operation.
4 	Troubleshooting - located in the fault troubleshooting menus. Preventive Maintenance "PM".	Press the button to access step-by-step troubleshooting procedures. Icon also alerts when preventive maintenance is due.
5 	Call for Service - located in the fault troubleshooting menus.	Press the button to access the service agent's phone number. The machine serial number is displayed as well.
6 	"Screen Back" - A navigation button located in the fault menus and other information sections.	Press the button to go back one screen in the instructions.

Table 3 - Fault icon legend

FAULT ICON LEGEND (continued)











Icon	Description	Function
7 	"Screen Forward" - A navigation button located in the fault menus and other information sections.	Press the button to go forward one page in the instructions.
8 	"HOME" or Main Screen - located in the lower right corner of fault menus and other information sections.	Press the button to return to the main operating screen.
9 	DOOR OPEN - located in the machine section where the fault has occurred.	Fatal fault that will prevent machine operation if not resolved. Press the door icon to access the troubleshooting menu. Press Icon #5 above to call service for repair.
10 	Yellow Conveyor Belt - Icon appears at bottom center of the main screen.	Denotes the conveyor belt is full. The fault is caused by dishes pushing the conveyor shut-off shelf to the off position. Conveyor stops, the pumps continue to run.
11 	Red Conveyor Belt (CONVEYOR JAM) - Icon appears at bottom center of the main screen. "Conveyor Jam" appears in the center of the icon.	Fatal flaw that stops the operation of the machine until the fault is corrected. Machine power should be turned off and the machine inspected for anything that may be jamming the machine. The anti-jam mechanism should also be inspected.
12 	Photoeye Fault - located at the bottom center of the main operating screen.	Critical fault where the conveyor photoeye was blocked when the machine was turned on resulting in the conveyor and pumps running continuously.
13 	Conveyor Drive Fault - located at the bottom center of the main operating screen.	Fatal Fault where the conveyor drive, (VFD), has failed. The machine will not run until the fault is resolved.
14 	Thermistor Fault - Four red XXXX located on the main operating screen in the the tank temperature field.	Critical fault of a thermistor in a wash tank or booster tank heater. The dishwasher will continue to run after the fault is acknowledged in the troubleshooting menu.
15 	Backup Battery Failure - Screen appears on HMI when PLC battery is low.	Critical fault when the PLC battery is running low. Contact service as soon as possible to have the battery replaced. Press the Home button to return to normal operation.
16 	System Fault - Appears on the HMI when a fatal error occurs.	Fatal flaw. Machine will not operate due to system failure. Service agent must be called to repair.

Table 3 - Fault icon legend (continued)

MACHINE STATUS SCREEN

- The Machine Status Screen gives the operator operation and troubleshooting data. However, this information is most often used by the service agent.

- The Status screen is accessed by pressing the "GEARS" button on the MAIN screen



← Gears access
Machine Status Screen

- **PERFORM DELIME NOW** and **PERFORM AUTOCLEAN NOW** are enabled when the machine is idle. The buttons disappear when the machine is running.
- Refer to page 17 for the **PHOTOEYE FAULT** operation.

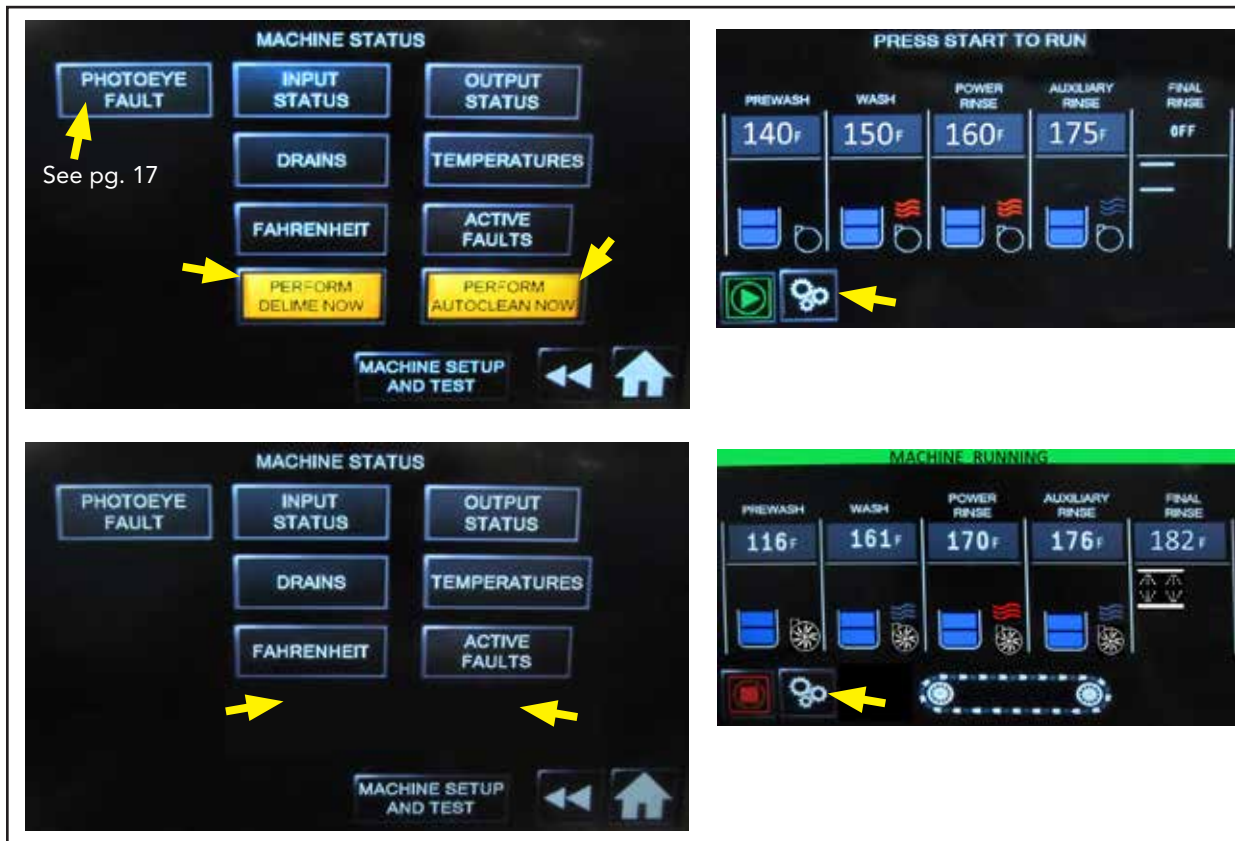

Fig. 23 - MACHINE STATUS SCREEN

Input Status - Used by service technicians

Displays the PLC inputs. Red means the input is open, green closed.

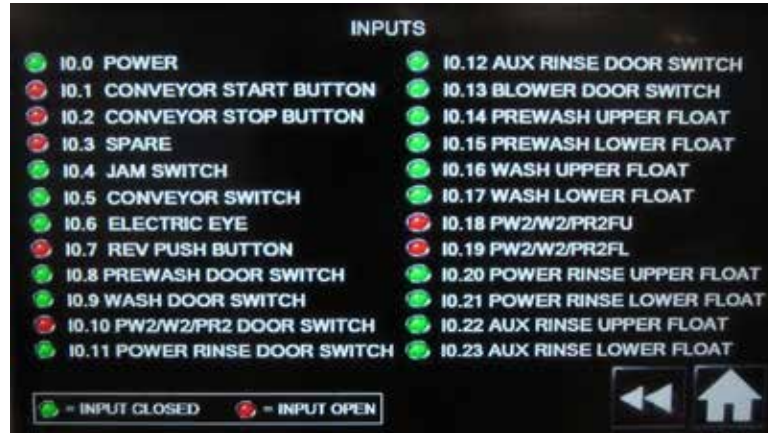

Fig. 24 - Inputs

Output Status - Used by service technicians.

Displays the PLC outputs. Red means deenergized, green energized.

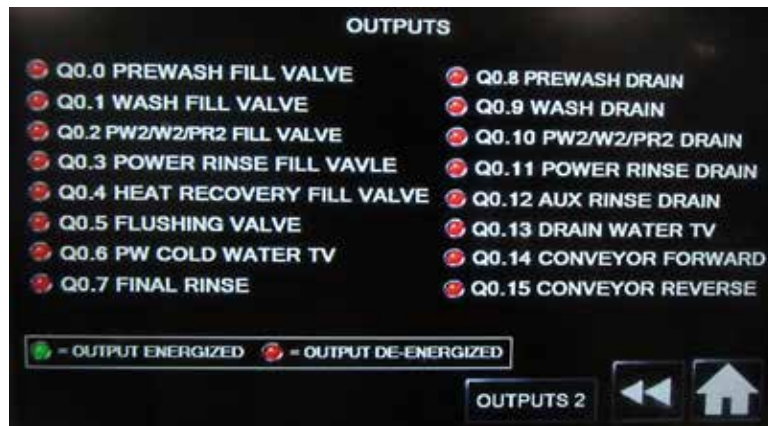

Fig. 25 - Outputs

Drain Status - Selecting drains stops the machine if running and opens all of the machine drains. Pressing HOME closes the drains.

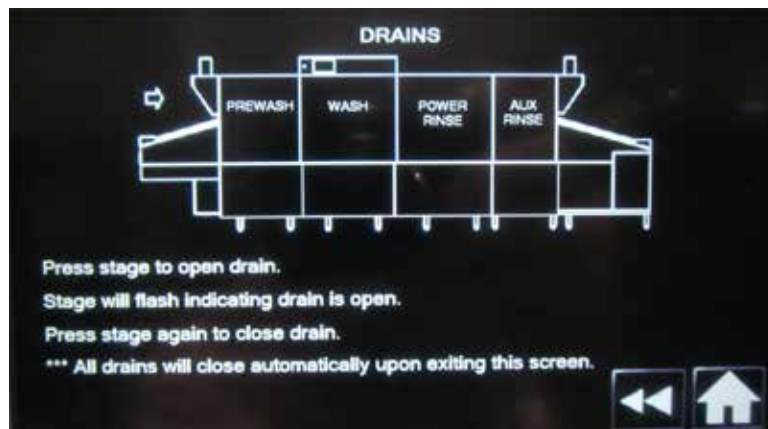

Fig. 26 - Drains

MACHINE STATUS SCREEN (continued)

Fahrenheit - Press the Fahrenheit button to change the temperature units from Fahrenheit °F to Celsius °C.



Fig. 27 - Fahrenheit/Celsius

Temperatures - current incoming water, tank, and final rinse temperatures displayed.



Fig. 28 - Temperatures

Active Faults - Active faults is a troubleshooting tool that displays a number of fault conditions occurring with the machine. Green circles indicate no faults. Red circles indicate a fault.

- The red colored circle on Final Rinse indicating a a Heat Check fault.
- Wash 1 is experiencing two faults simultaneously, i.e., a Fill Time Exceeded and a Float Switch fault.
- These displays provide the service agent with valuable data to resolve faults.



Fig. 28 - Active Faults

MACHINE SETUP AND TEST for Supervisors with Password 7777.

- This menu is reserved for supervisors needing to test/change a limited number of machine parameters.



Fig. 29 - Machine Setup and Test

- Press the "Machine Setup and Test" to access the password screen
- Press the "ENTER PASSWORD" block. The keypad appears.
- Press 7777 and ENT.



Fig. 30 - Enter 7777

- Press the "Machine Setup and Test" to access the password screen
- Press the "ENTER PASSWORD" field to bring up the keypad.
- Press 7777 and ENT.
- The Supervisor set-up screen appears.



Fig. 31 - Supervisor Machine Setup and Test Menu Screen

continued on next page

MACHINE SETUP AND TEST for Supervisors with Password 7777.

Machine Speed - changes conveyor belt speed.



Fig. 32 - Machine Speed

Service Phone # - Phone no. appears throughout the programs.

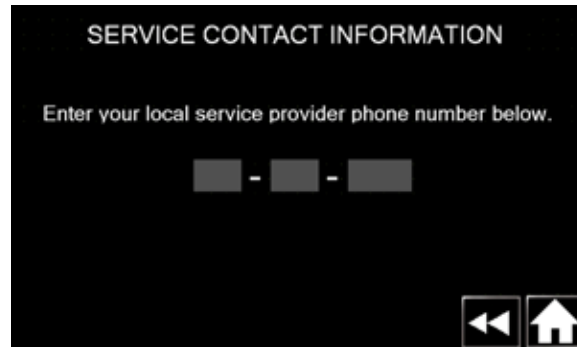



Fig. 33 - Enter Phone Number

Delime Setup - Turns delime on or off. Sets time interval between delimes. Sets operation. Activates flashing  symbol to alert operator Delime is due.

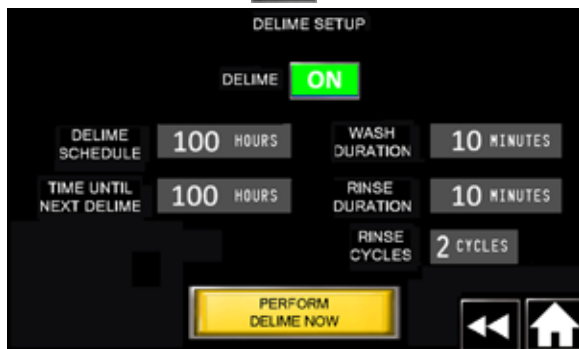



Fig. 34 - Delime Setup

CLEANING

AUTOCLEAN - is an interim automatic feature to perform a quick clean at the end of a shift or 8 hours of continuous operation, whichever occurs first.

 **CAUTION:** The autoclean feature is not a substitute for the extensive cleaning required at the end of the day.

To perform an autoclean operation:

- 1 Make sure the machine is idle, then press the "Gears" icon.



- 2 Press the "PERFORM AUTOCLEAN NOW" button.

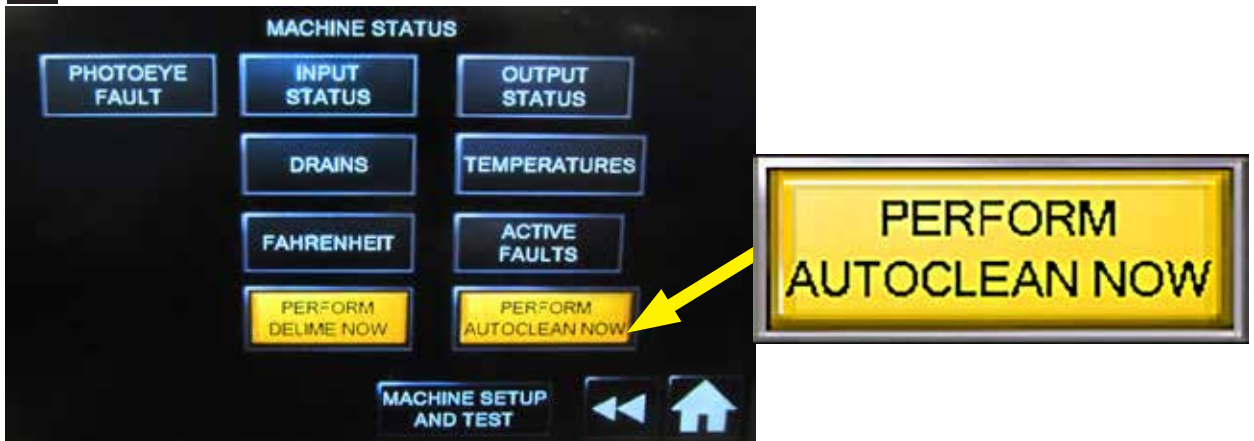

continued on next page

Cleaning

CLEANING - AUTOCLEAN (continued)

Follow the Autoclean instructions below:

- 3** Press YES to begin Autoclean. Press NO to return to the MAIN operator screen.

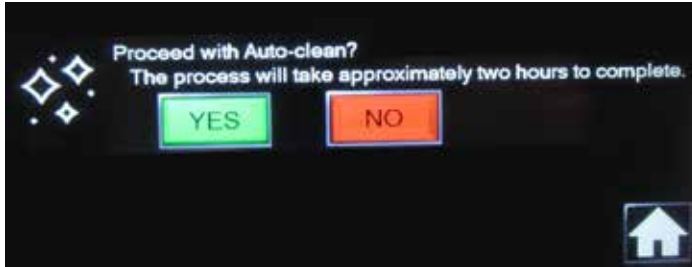

- 4** Machine drains automatically. Press and Hold the red button for 3 seconds to cancel the Autoclean process. The screen will return to the MAIN screen.

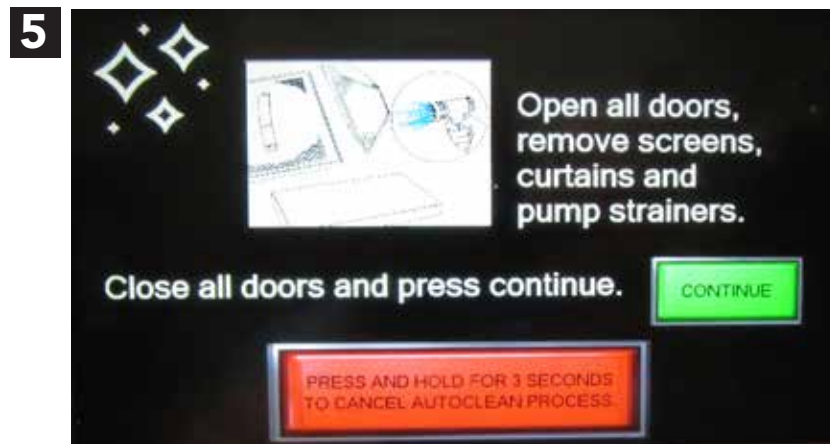

6 Machine fills.



7 This screen appears if a door is opened while machine is filling.



8 The "Cleaning in Process" appears with the "Time remaining" counter to indicate the elapsed cleaning time in 4, 2 and 1 minute intervals.

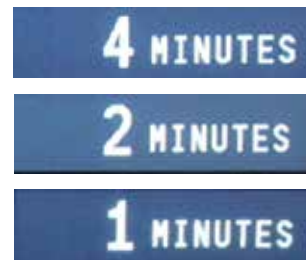
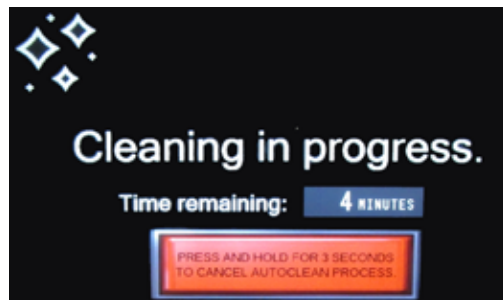

9 Operator is prompted to reassemble the machine when Autoclean is complete.

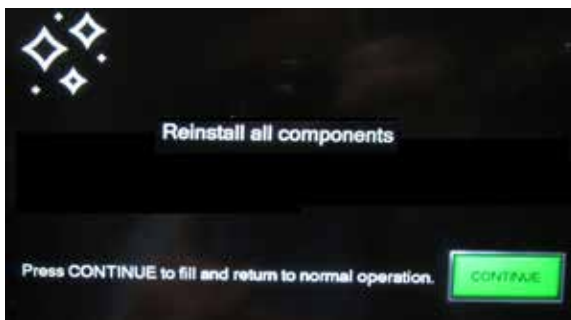

10 The machine returns to normal operation at the end of the Autoclean process. The Machine Filling is displayed.



CLEANING - AT THE END OF THE DAY

THE MACHINE REQUIRES THE OPERATOR TO THOROUGHLY CLEAN THE MACHINE AT THE END OF DAY.



WARNING:

Never clean the machine with a steel brush or scouring pad.
Steel leaves rust deposits on machine surfaces.

Perform the procedure below to manually clean the machine:

- Push the green power button to turn the machine off. Machine will drain.
- Remove the curtains and clean with mild detergent in a sink. Flush with fresh water and set aside.
- Remove the upper and lower spray arms, remove the end plugs and flush arms with fresh water in a sink. Make sure the end plug o-rings are in good condition (Fig. 35).
- Remove the scrap screens and baskets. Take care that debris does not fall into machine when removing. Flush and back flush in a sink.
- Remove the pump suction strainers, clean in a sink (Fig. 36).
- Inspect and clean the auxiliary and final rinse nozzles. Use a staple to clean the auxiliary nozzles and a paper clip for the final rinse arms (Fig. 37).
- Spray the conveyor belt and machine interior with fresh water.
- Clean the floats and make sure they move freely.
- Clean the electric heating elements, or steam coils as equipped. Lightly scrub scale from the heating elements using a Scotch-brite™ or comparable scrub pad.
- Clean the exterior of the machine with a mild detergent and soft cloth.
- Reassemble the machine and leave doors open to aid in overnight drying.

**This Page
Intentionally
Left Blank**

DELIMING



WARNING:

Consult the chemical representative's recommendations when using delimiting chemicals. Wear protective clothing, goggles and face shield when handling chemicals.

NOTE: The delime setup parameters are set at the factory but may be changed by the supervisor if desired (see pages 23-24). Delimiting time is between 4-6 hours.

- The Main screen will display the delime icon when it is time to delime the machine. This icon will continue to appear until the operator performs the delime procedure (Fig. 35).
- Press the Delime icon to begin the delime procedure.

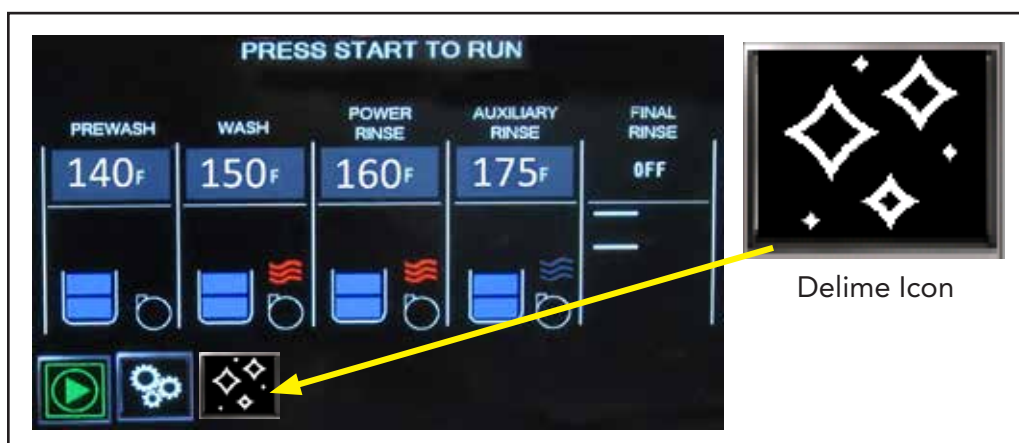

Fig. 35 - Automatic delime message.

- The operator can manually begin a delimiting from the Machine Status screen if the machine is idle (Fig. 36). Press the GEARS icon to access the Machine Status screen.
- Press the "PERFORM DELIME NOW" to begin the delime procedure.

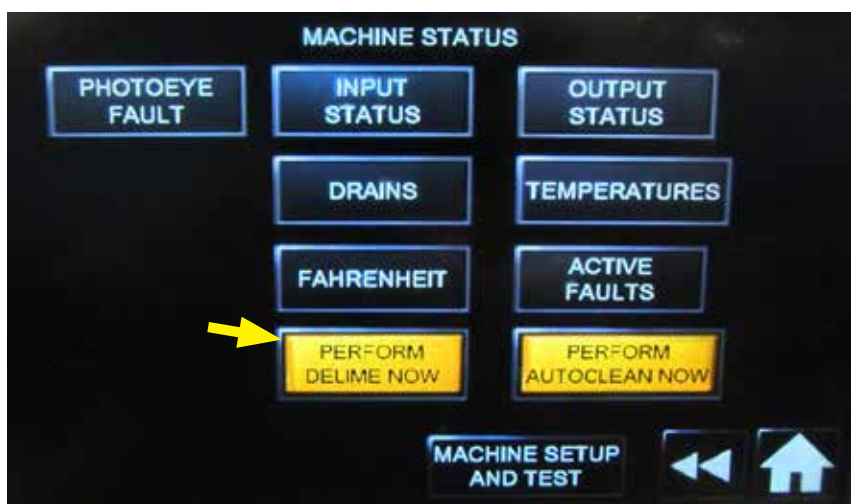
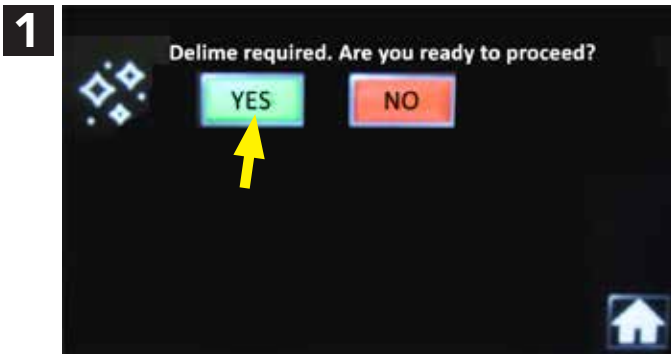

Fig. 36 - Perform delime now.

- Press NO to cancel and return to the Main screen and continue normal operation. The Delime icon will continue to be displayed until the deliming is performed.
- Press YES to continue the delime procedure.



- Press and hold the red button for 3 seconds to cancel deliming, otherwise, the machine drains completely.



- Open all doors. Deliming will not begin if all doors are not opened.
- Follow the instructions.
- Press the CONTINUE button.



Deliming

DELIMING (continued)

- CLOSE DOORS TO FILL will appear if a door is open. Make sure doors are closed.
- Machine will fill.



- Open the doors and add the delime chemical in accordance with the chemical supplier's instructions. Press continue. Close the doors to begin the process.
- The pumps will run for a preset time set at the factory.
- **NOTE:** Deliming can not be cancelled after the chemicals are added to the machine.

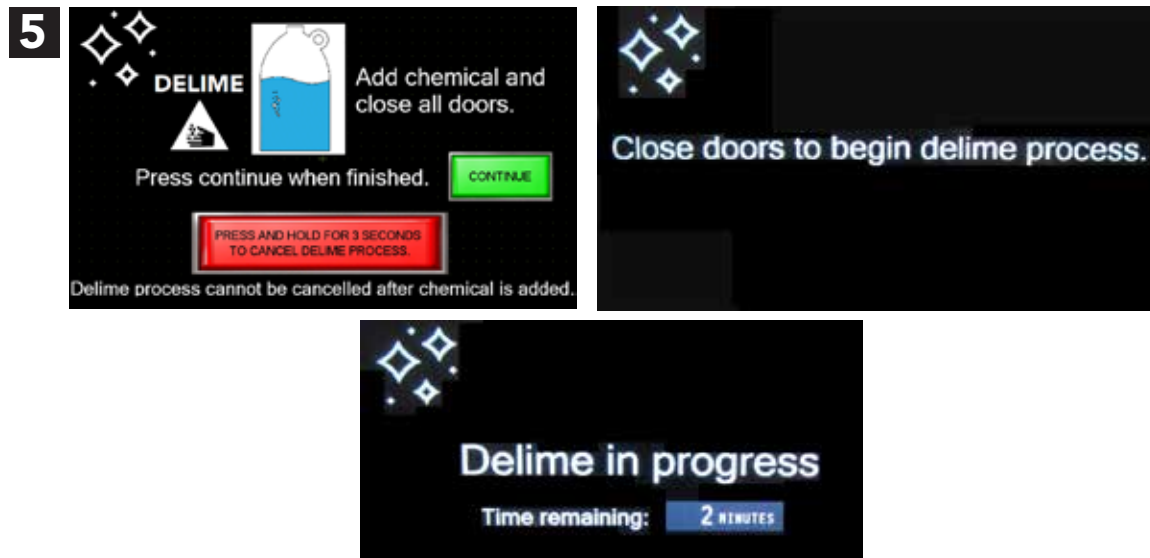

- The machine will drain, fill, and rinse for the programmed cycles and times until the deliming process is complete.
- The screens below appear during the deliming.

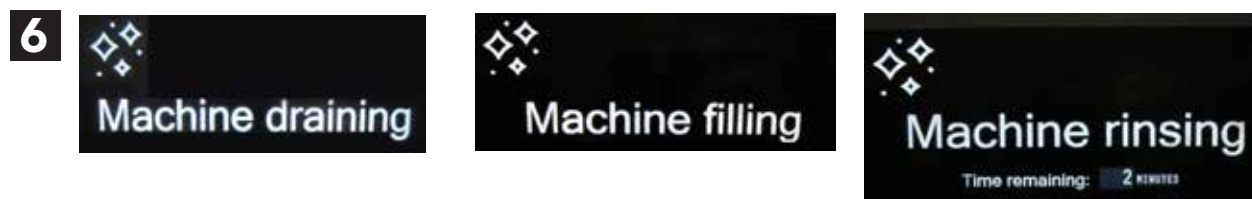

- A power loss does not cancel the deliming process. The machine remembers where the process was stopped and will resume when the CONTINUE button is pressed.

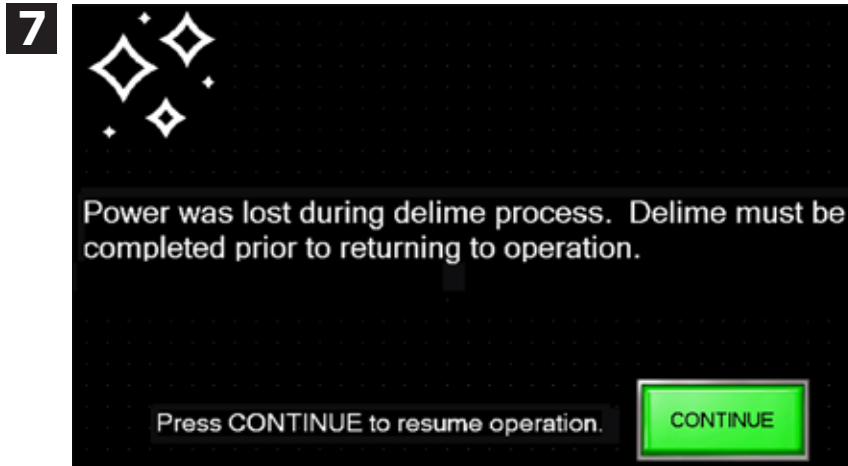

- DELIME COMPLETE displays when the process is complete.
- Open the doors and reinstall components.
- Press CONTINUE to return to normal operation.

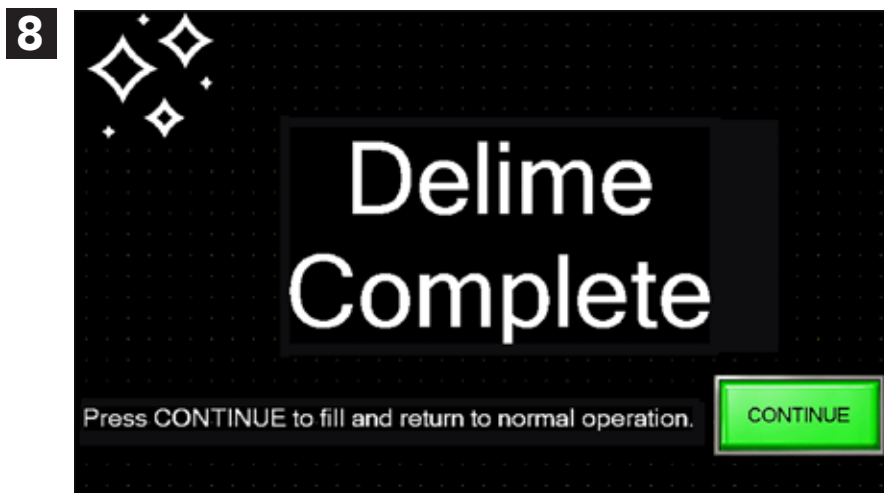

**This Page
Intentionally
Left Blank**