

# Champion®

## Installation/Operation Manual



*EUCCW-8 / EUCC-8*



*EUCCW-6 / EUCC-6*



*EUCCW-4 / EUCC-4*

### Eseries High Temperature Upright Conveyor Dishwasher

Models:

**EUCCW** 29" wide conveyor with a 4', 6', or 8' center section

**EUCC** 24" wide conveyor with a 4', 6', or 8' center section



[championindustries.com](http://championindustries.com)

Issue Date: 12.2.25

**Manual P/N 114254 rev. M**

For machines beginning with S/N J10012728 and above

3765 Champion Boulevard,  
Winston-Salem, NC 27105  
336/661-1556 Fax: 336/661-1660  
Toll-free: 800.858.4477

2674 N. Service Road, Jordan Station  
Ontario, Canada L0R 1S0  
905/562-4195 Fax: 905/562-4618  
Toll-free: 800.263.5798

Printed in USA

T

## National Service Department

In Canada:

Toll-free: 1(800) 263-5798

Tel: (905) 562-4195

Fax: (905) 562-4618

In the USA:

Toll-free: 1(800) 858-4477

Tel: (336) 661-1556

Fax: (336) 661-1660

## INSTALLATION DISCLAIMER

### CAUTION:

Plumbing and electrical connections should be made by qualified personnel who will observe all the applicable plumbing, sanitary, and safety codes and the National Electrical Code.

### Note:

Water Hammer Arrestor (meeting **ASSE-1010** standard or equivalent) to be supplied (by others) in common water supply line at service connection.

### Plumbing Notes:

Because of the variation in house-supplied steam and water pressures, steam and water pressure regulating valves, (PRVs) may be needed. (Water PRV is standard on machines with booster). The PRVs can either be purchased from Champion or obtained locally.

Champion does not endorse using on-demand (tankless) water heating systems, as well as PEX and other plumbing materials that may limit water flow as these could impair machine performance. For optimal results, we recommend using appropriately sized conventional hot water tanks and standard copper water supply lines that adhere to our specifications. Not following these recommendations may void the manufacturer's warranty. Water hardness of 3 grains/US Gal. (0.83 Imp. Gal.) - 5.3 Mg/L or less.

### Venting Notes:

Fabricated duct size: 3-7/8" x 23-7/8" (outside dimensions).

### Note:

Freezing air must not be allowed to be drawn down into the heat recovery coil when building vent fan is off if direct vent ducting is connected to the machine.

### Optional Drain Tempering:

1/2" NPT cold water connection required. 1/2" NPT drain connection from back flow preventer to house drain, (FIELD INSTALLED and PLUMBED).



# REGISTER YOUR PRODUCT AND ACTIVATE YOUR WARRANTY

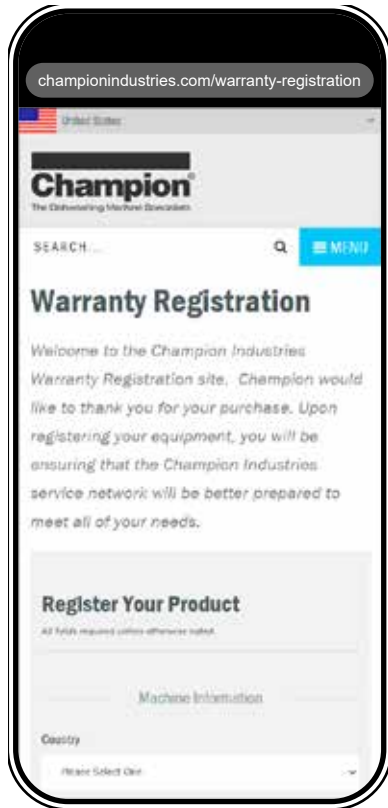

ENGLISH



FRANÇAIS CANADIEN

- Use your mobile device and scan the QR code above to connect to <https://www.championindustries.com/warranty-registration> and complete the registration form.

**or**

- Enter <https://www.championindustries.com/warranty-registration> into your browser and complete the registration form.

**or**

- FAX the form on page ii or mail the form in a stamped self-addressed envelope to the appropriate address listed below:

WARRANTY REGISTRATION  
Champion Industries  
3765 Champion Boulevard  
Winston-Salem, NC 27105, USA

WARRANTY REGISTRATION  
Champion Industries  
2674 N. Service Road, Jordan Station  
Ontario, Canada L0R 1S0

# PRODUCT REGISTRATION BY FAX

COMPLETE THIS FORM AND FAX TO:

(905) 562-4618 in Canada  
(336) 661-1660 in the USA

## PRODUCT REGISTRATION

Model:

Serial Number:

Installation Date : \_\_\_/\_\_\_/\_\_\_

Company Name: \_\_\_\_\_

Address: \_\_\_\_\_ (Street) \_\_\_\_\_ State/Province Zip/Postal Code

Telephone: ( ) \_\_\_\_\_ --- \_\_\_\_\_

Contact: \_\_\_\_\_

Installation Company: \_\_\_\_\_

Address: \_\_\_\_\_

Telephone: \_\_\_\_\_

Contact: \_\_\_\_\_

**FAILURE TO REGISTER YOUR PRODUCT MAY VOID THE WARRANTY**

**IMPORTANT IMPORTANT**

## Revision History

<b>Revision Date</b>	<b>Revised Pages</b>	<b>Serial Number Effectivity</b>	<b>Revision Description</b>
3.16.07	All	J2089	Issue of First Edition
3.22.07	All	J2089	Revised Parts Format
7.27.07	All	J2089	Added 575VAC Parts
11.18.08	All	J08102541	Added Digital Display
10.5.09	All	-----	Changed P/N's for Clutch
12.6.09	63-71	J09062644 Gasket	Added Standpipe
1.6.10	181,183	J09062644	Corrected P/N's 45, 46, 47
2.10.10	92,94,102	J09062644	Changed 1/4" plug to 1/8" plug for rinse injector
2.10.10	176-183	J10012728	Updated P/N's and added new control cabinet layout
8.10.10	114,116,120 124, 128,130	J10012728	Changed 1" Steam to P/N 114800
8.25.10	104-105, 108-109	J09062644	3/4" solenoid valve changed to 1/2"
8.25.10	166-170	-----	Added EUCC belts
8.25.10	204-208	J09062644	Added swing-out doors
5.2.11	194, 198	J08102541	Corrected Item 35 P/N from 111980 to 114505
2.28.17	30-33	J11062899	Changed clutch to anti-jam switch design added VFD drive.
5.6.19	211-220	J11062899	Updated parts lists and electrical schematics
8.21.19	190, 194,198	All	Changed Items 21,22 from P/N 112351 & 112352 to P/N 114640 & P/N 114641
5.11.20	89	All	Changed Item 24 to P/N 113604
12.2.25	47-220	All	Deleted Parts and Schematics. Replaced by manual, "FLT Parts_117990.pdf"

Dear Owner:

Thank-you for choosing our dishwasher.

We appreciate your business.

This manual covers two models:

EUCCW      Electric high temperature flight-type conveyor dishwasher with built-in  
EUCC      electric booster in 40° F/22° C rise or an optional 70° F/39° C rise booster.

EUCCW      Steam high temperature flight-type conveyor dishwasher with built-in  
EUCC      steam booster in 40° F/22° C rise or an optional 70° F/39° C rise booster.

*The installation, and initial start-up of your dishwasher must be performed by qualified electricians, plumbers, and authorized service technicians trained in commercial dishwashers.*

*Defects and repairs caused by unauthorized installers will not be covered by the dishwasher warranty.*

# **Table of Contents**

## **E series Upright Conveyor Dishwashers**

Revision History	iii
Limited Warranty	iv
<b>Operating Instructions</b>	<b>1</b>
Construction	
How to Operate your Dishwasher	
Cleaning and Maintenance	
Troubleshooting	
<b>Installation</b>	<b>21</b>
The plumbing and electrical connection diagram, (P&E).	
Unpack and Place	
Order of Assembly	
Section Assembly	
Water Connection	
Drain Connection	
Electrical Connection	
Ventilation	
Initial Start-up	

## LIMITED WARRANTY

Champion Industries, Bi-Line Systems (herein referred to as ("The Companies"), 3765 Champion Blvd., Winston-Salem, North Carolina, 27105) warrants machines and parts, as set out below:

**WARRANTY OF MACHINES:** The Companies warrant all new machines of its manufacture bearing the name Champion or Bi-Line and installed within the United States to be free from defects in material and workmanship for a period of one (1) year from the date of installation or fifteen (15) months from the date of shipment by The Companies, whichever occurs first. This Limited Warranty does not cover products shipped outside of the United States. The warranty registration card must be returned to The Companies within ten (10) days after installation or registered online at [www.championindustries.com/warranty-registration](http://www.championindustries.com/warranty-registration) for the United States. If the online warranty is not sent to The Companies within fifteen (15) days, then the warranty will expire after fifteen (15) months from the date of shipment. The Companies will not assume any responsibility for additional installation costs in any area with jurisdictional problems with local trades or unions. The Companies reserve the right to repair or replace a defective part or the entire machine, if a defect in workmanship or material is identified within the warranty period. Alternatively, The Companies may elect to accept the return of the machine for a full credit. In the event The Companies elect to repair, then the labor and work performed in connection with the warranty shall be done by The Companies' authorized service agent during regular working hours and at regular labor rates. Overtime charges are the responsibility of the equipment purchaser. Warranty travel is to be covered up to fifty (50) miles from the authorized service technician's servicing office. If travel exceeds fifty (50) miles, the end user will be responsible for any additional travel expense. Service calls initiated under warranty and found not to contain any defects in materials or workmanship, will not be covered by The Companies' warranty. Defective parts become the property of The Companies. Use of non-OEM replacement parts, not authorized by The Companies, will relieve The Companies of all further liability in connection with its warranty. In no event, will The Companies' warranty obligation exceed the charge for the machine. Machines that come with a factory-paid start-up will be limited to one (1) authorized service call for start-up. Installation problems or delays, of any kind, will not be covered by The Companies' warranty and will be the sole responsibility of the equipment purchaser.

### THE WARRANTY DOES NOT COVER:

- a. Chemical tubing, O-rings, or curtains.
- b. Vacuum breakers.
- c. Adjustments to structural or mechanical components covered by recommended maintenance procedures.
- d. Replacement of fuses, resetting of overload breakers, or high-limit thermostats.
- e. Adjustments of thermostats or other temperature controlling devices.
- f. Adjustments of clutches.
- g. Adjustments of water pressure(s).
- h. Adjustments of factory chemical pumps and settings.
- i. Opening or closing of utility supply valves or switching of electrical supply current.
- j. Cleaning of valves, strainers, screens, nozzles, or spray pipes.
- k. Regular maintenance and cleaning as outlined in the operator's guide.
- l. Damages resulting from water conditions, accidents, alterations, improper use, abuse, tampering, improper installation, under or over voltage conditions, power surges, inadequate wiring, outdoor use, or failure to follow maintenance and operation procedures.
- m. Pulper cutter blocks, pulse vanes, and auger brush due to wear and tear.
- n. Damages due to improper storage.
- o. Special installations or applications, including remote locations, are limited in coverage by this warranty.
- p. Any installation that requires additional work and/or travel to gain access to a machine for service is the sole responsibility of the equipment purchaser.

### THE FOLLOWING DEFECTS ARE NOT COVERED BY THE WARRANTY:

- Damage to the exterior or interior finish.
- Damage caused by improper connection to utility service other than that designated on the rating plate.
- Inadequate or excessive water pressure.
- Corrosion due to foreign materials, improper water supplies, improper chemicals, or chemicals dispensed in excess of recommended concentrations.
- Failure of components due to the connection of third-party chemical dispensing equipment installed by others.
- Leaks and damage due to the use of non-specified water quality.
- Leaks and damage caused by the installer, including machine table connections.
- Leaks or damage caused by chemical dispensing equipment connections installed by others.
- Failure to comply with all local building codes.
- Damage caused by labor dispute.

**WARRANTY OF PARTS:** The Companies warrant all new machine parts produced or authorized by The Companies to be free from defects in material and workmanship for a period of ninety (90) days from the date of invoice. If any parts defect in material and workmanship is found to exist within the warranty period, then The Companies will refund the cost of the defective part.

### DISCLAIMER OF WARRANTIES AND LIMITATIONS

**OF LIABILITY.** THE COMPANIES' WARRANTY IS ONLY TO THE EXTENT REFLECTED ABOVE. THE COMPANIES MAKE NO OTHER WARRANTIES, EXPRESS OR IMPLIED, INCLUDING, BUT NOT LIMITED TO ANY WARRANTY OF MERCHANTABILITY OR FITNESS OF PURPOSE. THE COMPANIES SHALL NOT BE LIABLE FOR INCIDENTAL OR CONSEQUENTIAL DAMAGES. THE REMEDIES SET OUT ABOVE ARE THE EXCLUSIVE REMEDIES FOR ANY DEFECTS FOUND TO EXIST IN MACHINES AND PARTS OF THE COMPANIES. ALL OTHER REMEDIES ARE EXCLUDED, INCLUDING ANY LIABILITY FOR INCIDENTALS OR CONSEQUENTIAL DAMAGES.

*Champion Industries or Bi-Line Systems does not authorize any other person, including persons who deal in Champion Industries or Bi-Line Systems machines, to change this warranty or create any other obligation in connection with Champion Industries or Bi-Line Systems machines.*

## **Operating Instructions**

### **IMPORTANT**

**Please read the steps below before you operate your dishwasher.**

1. Make sure the dishwasher was properly installed and tested prior to operation.
2. Read the operating instructions completely before you operate your dishwasher for the first time.
3. Keep these instructions available for quick reference.
4. Contact your supervisor immediately if you have questions about the dishwasher.
5. Contact your local authorized Champion service agency for technical support.
6. Our National Service Department provides 24 hour support 365 days a year with a Toll-free number in the United States.

**USA National Service**  
**M-F • 8 AM - 5PM EST**  
**Toll-free: 1 (800) 858-4477**

*In the USA, a factory technician will return your call after-hours and during holidays.*

***or***

**Canadian National Service**  
**M-F • 8:30 AM - 4:30PM EST**  
**Toll-free: 1 (800) 263-5798**

## **Operating Instructions**

### *Dishwasher Construction*

1. The Upright Conveyor dishwasher, (also called the flight-type conveyor), is assembled as a single unit from sections or modules.
2. This basic design is then customized to the customer's specifications.
3. The information presented below explains the basic construction of the upright conveyor dishwasher. It does not cover custom-built innovations.
4. Study the diagrams on the next page, then continue reading below.

#### **Dishwasher Sections:**

Five sections make up the basic assembly. The sections are:

Load, Prewash, Wash, Rinse, Final rinse, Unload

#### **Dishwasher Views:**

Plan View

Elevation

Side View

# Operating Instructions

## All Models

The diagrams below are an example, your machine may be different.

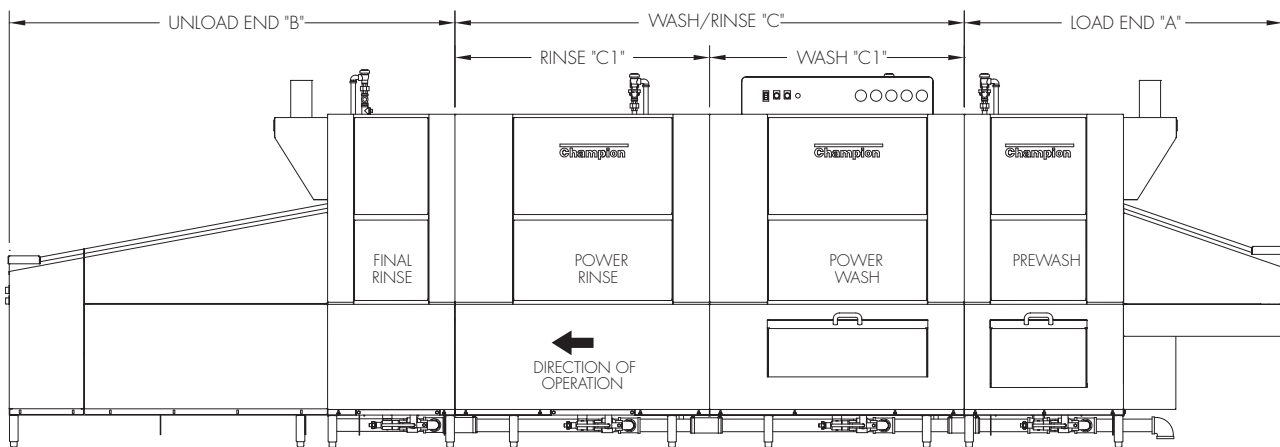
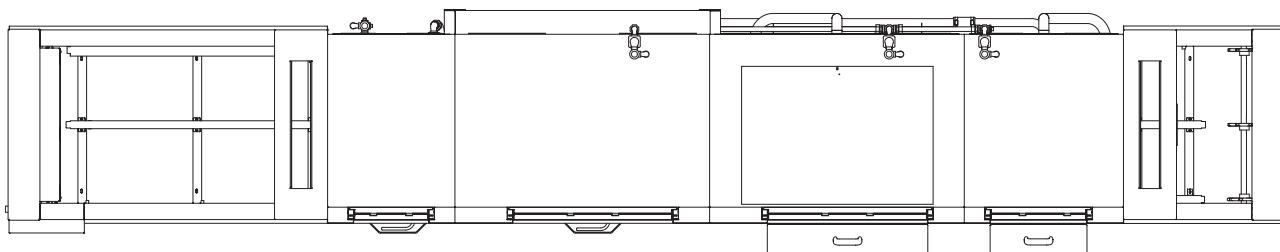

## Operating Instructions

**DO NOT flip the *dishwasher* power switch "ON" until you check the items below.**

1. Check that the following utilities are connected:  
to the dishwasher and ready for use:
  - Electrical service
  - Hot water supply
  - Drain
  - Ventilation
2. Check the chemical connections and chemical containers are installed and ready for operation, (*Consult your chemical supplier for instructions*).
3. Check the interior of the dishwasher for foreign objects and remove.
4. Turn on the water supply to the dishwasher.
5. Turn on the main power switch at the building service disconnect switch.

## Operating Instructions

1. Close all drains.

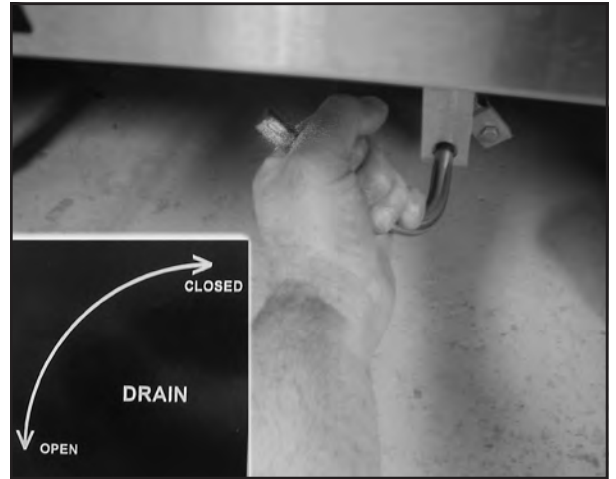

2. Make sure floats, overflows, drain screens, and pump screens are clean and in place.

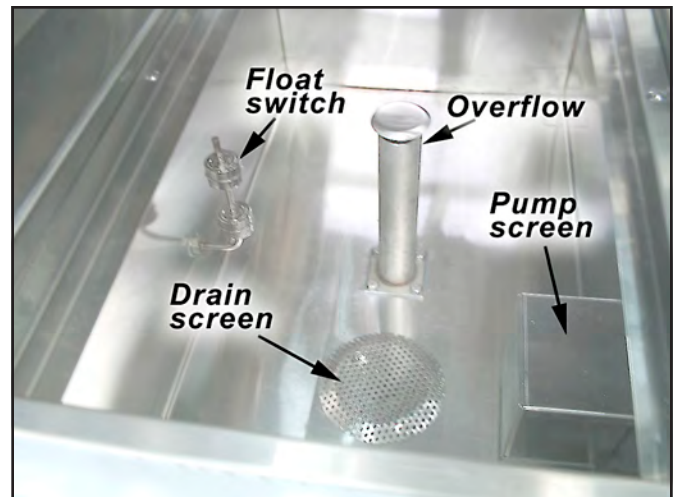

3. Always slide the pump screens up and lift out.

4. Check the bottom to make absolutely sure they are clean.  
Replace in reverse order

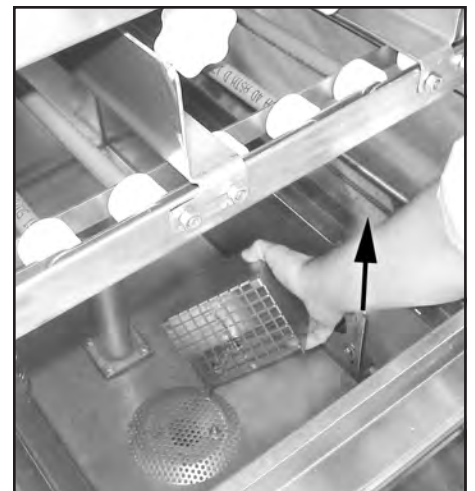

## Operating Instructions

1. Place the curtains in the dishwasher making sure the short flaps face the load end of the machine.
2. To install the curtains: Locate the curtain hooks in each section.
3. Place the curtain rod in the rear hook, then lift the opposite end of the curtain rod and place it in the front hook.
4. Place the 19" long curtains at each end of the dishwasher.
5. Place the 14" center curtains in each section.
6. Place the 10" final rinse curtain between the final rinse and auxiliary rinse pipes.

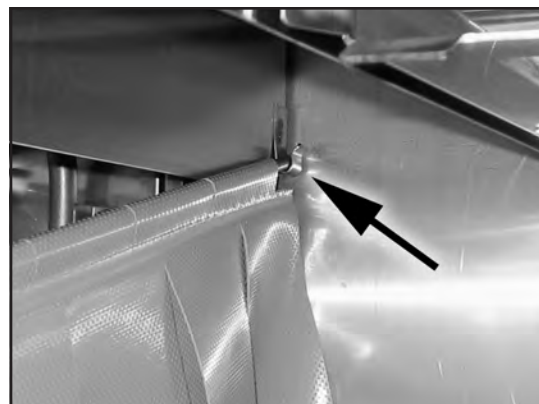

## Operating Instructions

7. Check the upper and lower wash arm manifold o-rings to make sure they are in place and in good condition.
8. Install the upper wash arm assemblies.
9. Install the lower wash arm assemblies.
10. Make sure all wash arm assemblies are locked in place.
11. The auxiliary rinse section is equipped with an upper and lower rinse arm.

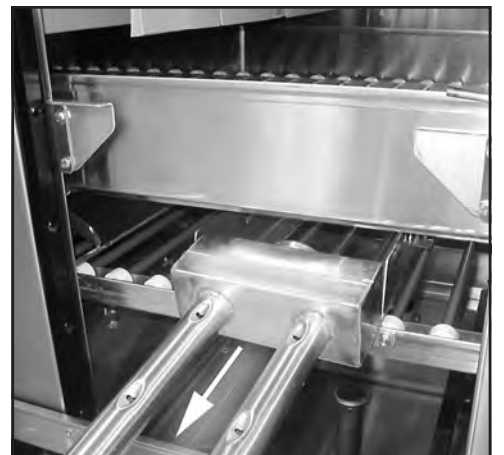
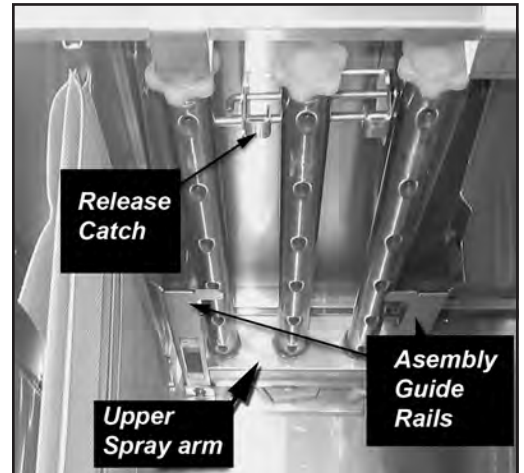

Refer to the illustrations on the next page for a more detailed view of the spray arms.

# Operating Instructions

TO INSTALL UPPER SPRAY ARM:

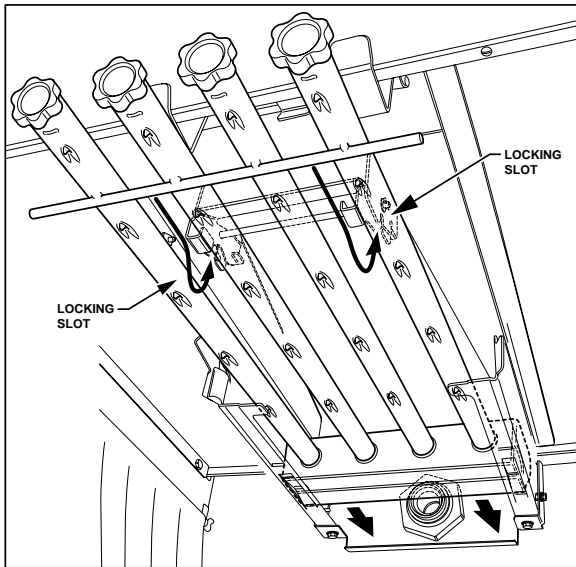

TO REMOVE UPPER SPRAY ARM:

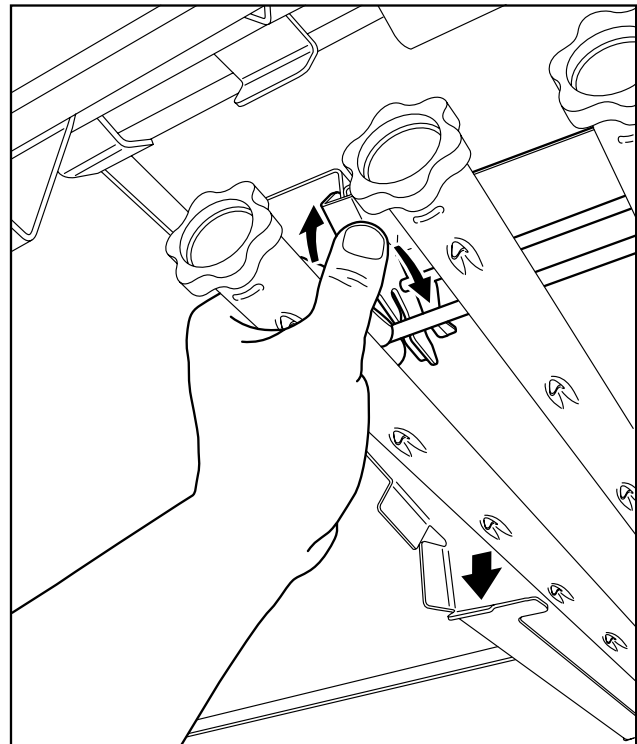
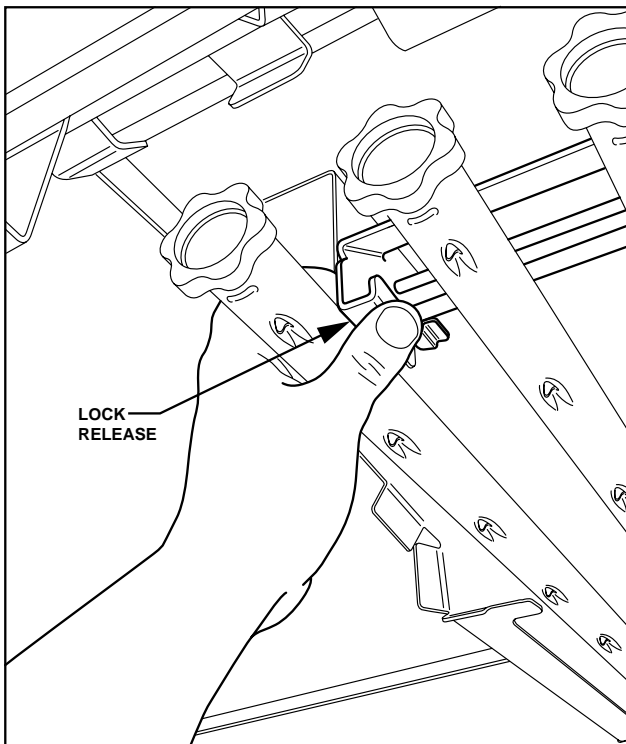
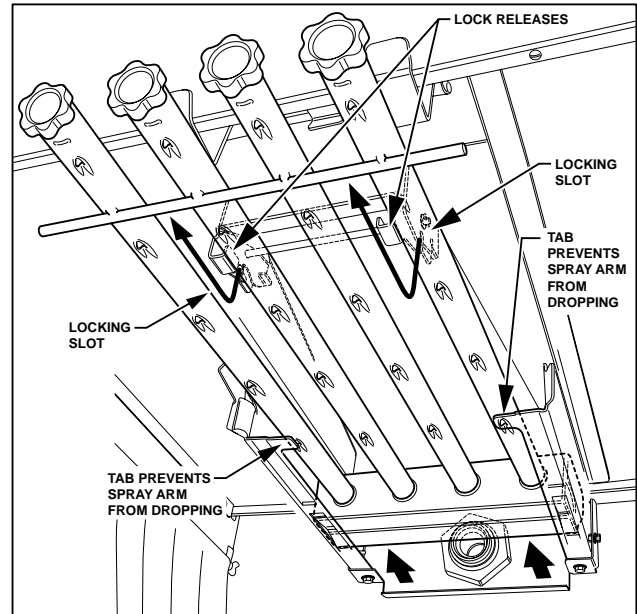

## Operating Instructions

12. There are 2 removable auxiliary rinse spray pipes in the auxiliary rinse section.

13. Make sure the upper and lower auxiliary rinse spray pipe gaskets are in place.



14. Position the spray pipe so the rinse nozzle points toward 10 o'clock.

15. Push the rinse pipe forward.

16. Turn the auxiliary rinse pipe 1/4 turn clockwise to lock it in place.

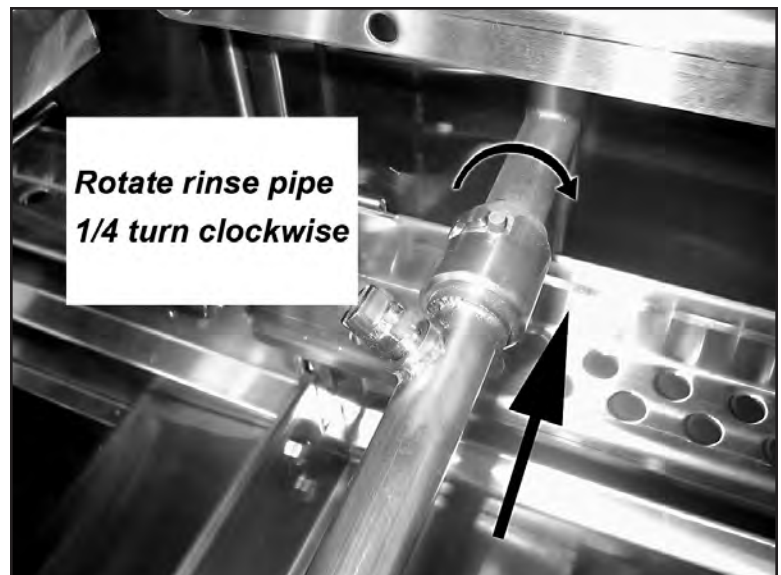

**Note:**

The final rinse pipes are permanently installed and do not require assembly.

## Operating Instructions

17. Install the scrap screens.



18. Install the scrap baskets if applicable.

19. Make sure the screens are fully seated to the rear of the dishwasher and interlocked into the scrap basket.



## Operating Instructions

20. Close all doors.

21. Lift the door up slightly, then push the door catch back toward the inside of the dishwasher.

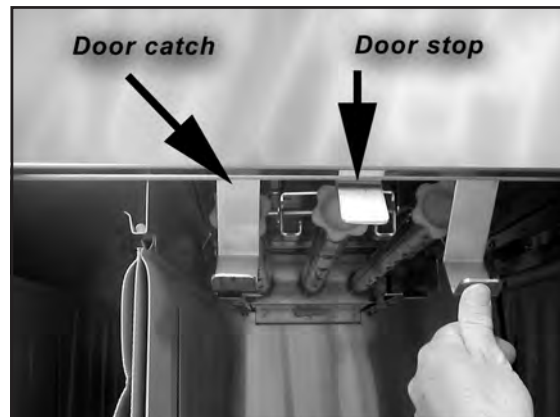

22. Slowly lower the door. The door catch remains disengage

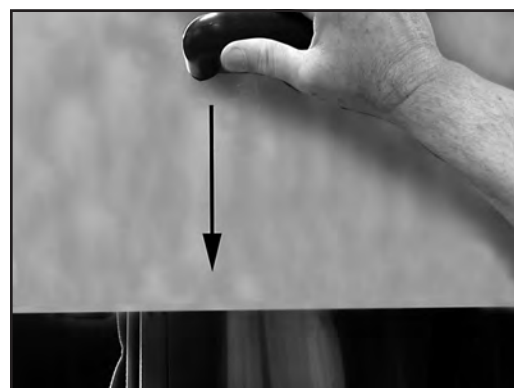

23. There are 2 half-size Econo-rinse doors. The operator lifts the upper door which hooks in place. Next, he lifts the lower door which hooks in front of the upper door. To lower the doors, the operator releases the lower door hook and closes the door then releases the upper door hook to close the upper door.



## Operating Instructions

24. Flip the dishwasher power switch up.
25. The dishwasher automatically fills with water.
26. The tank heat comes on as soon as the tanks are full.
27. Wait for 15-20 minutes to allow the wash and rinse tanks to reach operating temperature.



The wash tanks, auxiliary rinse, and final rinse water temperatures are displayed on digital displays located on the right-side of the control panel. The displays are labeled according to the tank or rinse water section that is being monitored. The illustrations above and below show the arrangement for a Right-to-Left dishwasher. The arrangement would be reversed for a Left-to-Right machine.

The minimum temperatures shown below must be maintained when the dishwasher is washing wares. A longer wait time or corrective measures should be taken immediately to maintain the temperatures.

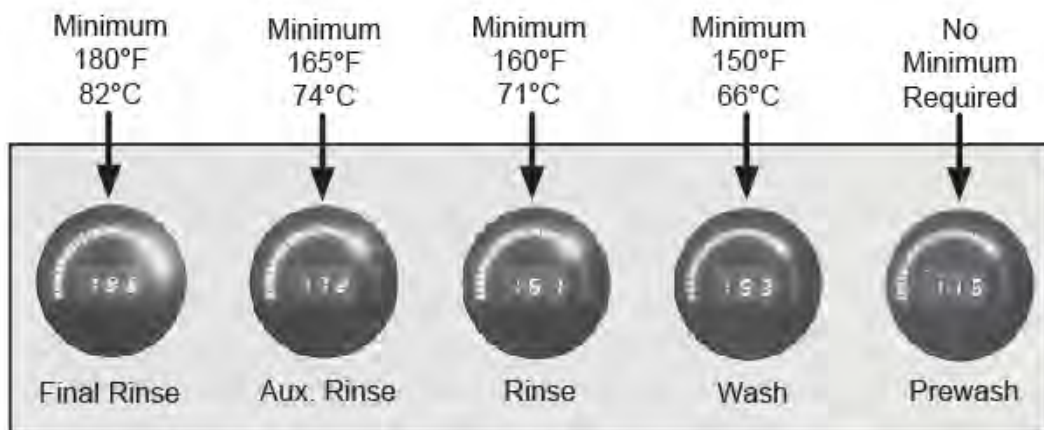

***The prewash tank is not heated so its temperature may be lower than the wash tank. This is okay.***

***The final rinse temperature is checked when the dishwasher conveyor belt and wash pumps are running during normal operation.***

## Operating Instructions

28. Push the **GREEN START BUTTON** to start the conveyor belt.

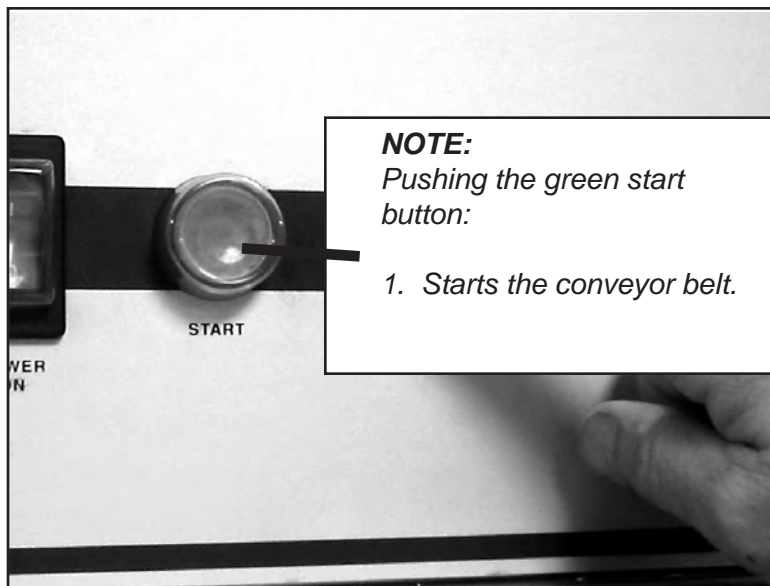

29. Push the **RED STOP BUTTON** to stop the conveyor belt.

The wash pumps stop.  
Tank heaters continue to operate.

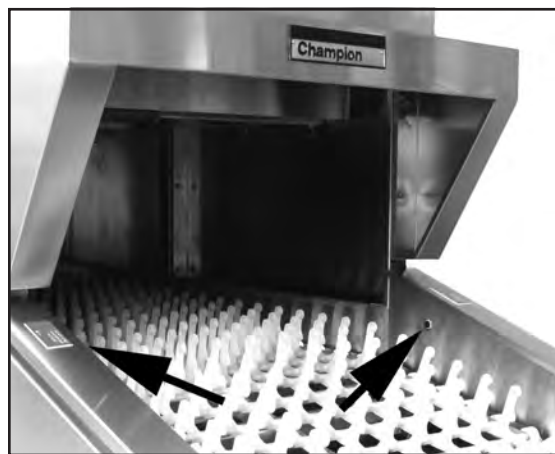

30. Push the **GREEN START BUTTON** to re-start the conveyor belt.

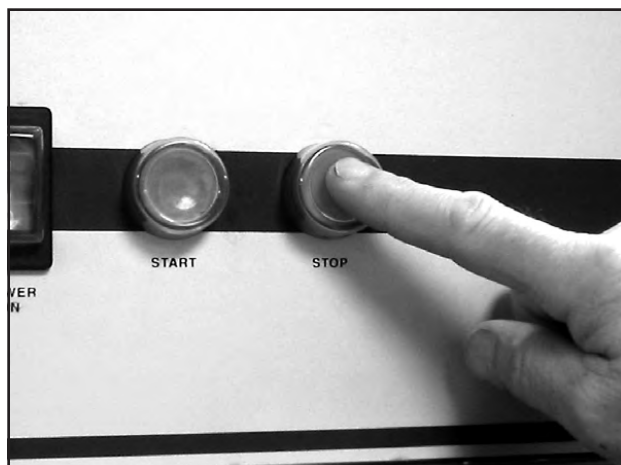

## Operating Instructions

31. Your dishwasher is equipped with start-stop stations. The load station is standard equipment; the unload station is an option.

These stations work exactly as the control cabinet start and stop buttons.

Start-stop stations make it possible for the person loading the wares on the conveyor belt to start and stop the dishwasher as needed.



*Load-end Start-Stop Station*

The person unloading the wares also has the ability to start and stop the dishwasher using the optional unload start-stop station (if it is installed .)

32. Push the GREEN START BUTTON to start the conveyor belt.
33. Push the RED STOP BUTTON to stop the conveyor belt.



*Optional Unload-end Start-Stop Station*

## Operating Instructions

34. An important safety feature designed to stop the conveyor belt during operation is the shut-off shelf.

This device is located at the very end of the unload section.

35. The shut-off shelf moves backward when wares contact it as the belt moves forward.
36. The shut-off shelf stops the conveyor belt. It also turns the blower dryer heat off (if equipped).

The wash pumps continue to operate when the shut-off moves backward to stop the conveyor belt.

37. The unload person may now remove the wares from their end of the dishwasher.
38. The conveyor belt begins moving again when the person moves the shut-off shelf back to its original position.

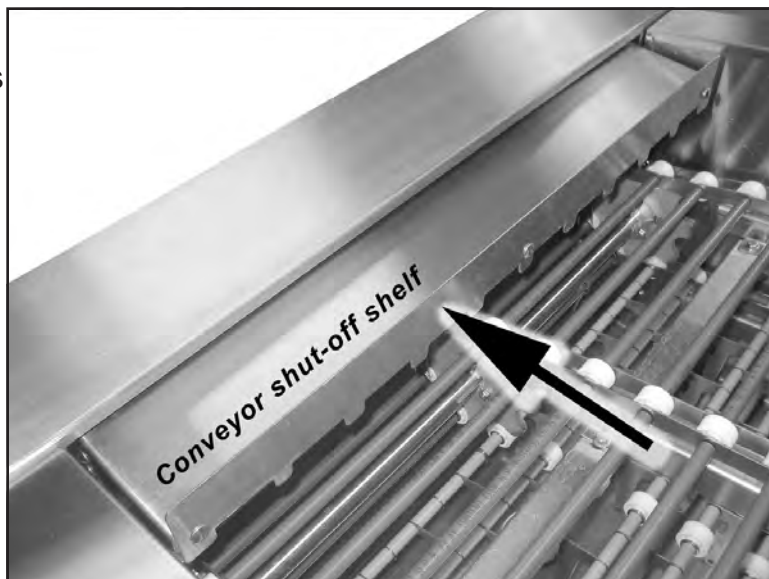

*Shut-off shelf in the RUN position*



*Shut-off shelf in the STOP position*

## ***Operating Instructions***

### ***Daily Maintenance***

1. Keep your dishwasher and the surrounding area clean.

After each meal period or every 2 hours of operation, whichever occurs first and at the end of the day.

Turn POWER OFF

Drain the dishwasher

Remove and clean the curtains

Flush the inside of the machine from top to bottom and all hidden places

Remove and clean scrap screens and baskets flushing with fresh water

Clean drain screens and pump screens

Wipe the exterior of the dishwasher with a soft cloth DO NOT HOSE WITH WATER

Leave doors open so the dishwasher may better dry overnight

2. Immediately report loose, broken or missing parts to your supervisor.
3. Check drains for flow restrictions.
4. Check the dishwasher for leaks.
5. Operate the dishwasher as explained in this manual.

### ***Monthly Maintenance***

1. Inspect pump hoses, door linkage, springs, and exterior of dishwasher for wear.
2. Inspect the wash arm bearings and O-rings.
3. Check the condition of scrap screens and dishracks for damage.
4. Check the toggle switches and indicator lights for damage.
5. Check the wash pump motor for loud bearings and leaking pump seal.

### ***Annual Maintenance***

Call your authorized service agent or local service representative and schedule a complete inspection of your dishwasher by our trained professionals.

***Schedule*** your annual maintenance when you can give the service agent unrestricted access to the dishwasher for at least 2 to 3 hours.

# ***Troubleshooting***

# Troubleshooting

On occasion your machine may not operate as expected. Use the checklist below before you decide that a mechanical or electrical failure has occurred.

**Checklist**

1. Are the main disconnect switches, breakers, or motor overloads turned ON?
2. Are the main water and steam supplies turned ON?
3. Are the drain valves closed?
4. Are the spray pipes and rinse nozzles clean?
5. Are the spray pipes in the proper locations?
6. Are the pump intakes clean?
7. Are the scrap screens clean and in place?
8. Are the thermostats correctly adjusted?
9. Are the high limit temperature thermostats reset?
10. Are the doors fully closed?
11. Are the conveyor shut-off and drive assemblies in operating condition?
12. Are the chemical supplies adequately filled?

If a problem still exists after verifying the checklist, refer to the following

CONDITION	CAUSE	SOLUTION
Conveyor will not run	Door not closed .....	Make sure doors are fully closed
	Door safety switch faulty .....	Contact your service agency
	Start switch faulty .....	Contact your service agency
	Main switch OFF .....	Check disconnect
	Control panel power switch OFF .....	Flip switch ON
	Conveyor shut-off shelf operated.....	Move shelf toward tunnel of machine
	Motor overload protector tripped .....	Reset overload in control cabinet
	Green start button not pressed .....	Press green start button

# Troubleshooting

CONDITION	CAUSE	SOLUTION
A single pump will not run	Motor overload tripped ..... Defective motor	Reset overload in control cabinet Contact your service agency
Low or no water	Main water supply is turned off ..... Drain valves are open..... Doors are not fully closed ..... Faulty fill valve ..... Stuck or defective float switch..... Cross-flow piping misadjusted/ clogged ..... Clogged strainer at supply connection ..... PRV misadjusted or defective.....	Turn on house water supply Close all drain valves Close doors Contact your service agency Free float /Contact service agency Adjust cross-flow setting/Clean piping Clean strainer screen Readjust pressure setting or replace PRV
Continuous water filling	Stuck or defective float switch.....  Fill valve will not close..... Drain valves open.....	Free float/Contact service agency  Clean valve,repair or replace valve Close drain valves
Wash/Rinse tank temperature low	Incoming water temp. at machine low.....  Defective thermometer ..... Defective thermostat ..... Defective electric heater element ..... Low steam pressure or volume ..... Defective steam trap..... Defective solenoid valve .....	Raise incoming temperatureis low 140°F minimum for 40°F rise booster 110°F minimum for 70°F rise booster 180° F minimum without booster Check or replace Readjust setting or replace Check or replace Check steam supply pressure Check or replace Check or replace
Prewash tank temperature is too high (Optional Cold Water thermostat Only)	Incoming cold water temperature too high..... Defective cold water thermostat .....	Lower incoming water temperature to maximum of 65°F Check or replace
Insufficient pumped spray pressure	Clogged pump intake screen ..... Clogged spray pipe..... Scrap screen full ..... Low water level in tank Pump motor rotation incorrect ..... Defective pump seal .....	Clean Clean Must be kept clean and in place Check drain valves Reverse wires L1 and L2 in control cabinet Contact service agency
Insufficient final rinse or no final rinse	Faulty pressure reducing valve (PRV) ..... Improper setting on PRV ..... Clogged rinse nozzle or pipe ..... Improper water line size..... Clogged "Y" strainer.....	Clean or replace Set Flow pressure to 20-22 PSI Clean Installer must change to proper size Clean or replace

# Troubleshooting

CONDITION	CAUSE	SOLUTION
Low final rinse temperature	Low incoming water temperature .....	Raise incoming water temperature 140°F for 40°F rise booster 110°F for 70°F rise booster 180°F without booster
	Defective thermometer .....	Check or replace
	Defective thermostat .....	Recalibrate or replace
	High limit thermostat tripped .....	Reset or replace
Poor washing results	Low steam pressure.....	Check steam supply pressure
	Detergent dispenser not operating .....	Contact the chemical supplier
	Detergent supplied not strong enough .....	Contact the chemical supplier
	Wash water temperature too low	See Condition "Wash/Rinse tank water temperature too low"
	Spray pipes clogged .....	Clean
	Improperly scrapped dishes .....	Check scrapping procedures
	Ware improperly loaded on conveyor .....	Stagger ware on belt
	Maintenance not performed as required .....	See Maintenance Schedule
	Electric elements/steam coils have .... lime build-up .....	Clean and delime Contact the chemical supplier
	Poor drying results	Excessive humidity in warewashing area .....
Improperly stacked dishes after washing .....		Check unloading procedures
Insufficient rinse-aid .....		Contact chemical supplier
Final rinse temperature too low .....		See Condition "Final Rinse temperature too low"

# Installation Instructions

## Plumbing and Electrical Diagram, (P & E)

1. The dishwasher P&E is a documented drawing that contains the critical data for the proper construction and utility connections for the dishwasher.
2. The P&E was reviewed and approved by all authorized persons prior to shipment.
3. The sample diagram below illustrates the format and presentation of the data necessary to connect the dishwasher.

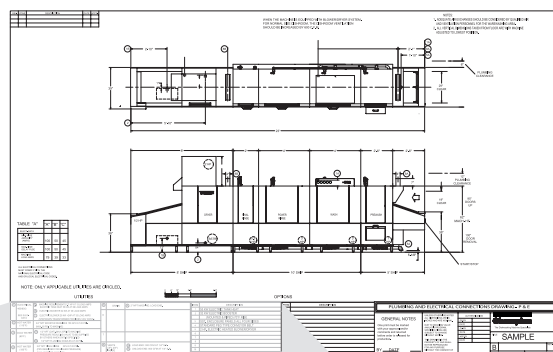

### UTILITIES

ITEM	DESCRIPTION	ITEM	DESCRIPTION
1	55 KW ELECTRIC TANK HEAT	1	55 KW ELECTRIC TANK HEAT
2	32 KW ELECTRIC BOOSTER (MOUNTED & PIPED) 70°F RISE	2	32 KW ELECTRIC BOOSTER (MOUNTED & PIPED) 70°F RISE
3	SST. ENCLOSURE PANELS ALL FOUR SIDES	3	SST. ENCLOSURE PANELS ALL FOUR SIDES
4	STANDARD PEG TYPE CONVEYOR BELT	4	STANDARD PEG TYPE CONVEYOR BELT
5	2 HP. ELECTRIC HEATED BLOWER/DRYER	5	2 HP. ELECTRIC HEATED BLOWER/DRYER
6		6	
7		7	
8		8	
9		9	
10		10	
11		11	

  

ITEM	DESCRIPTION	ITEM	DESCRIPTION
①	ELECTRICAL 460/60/3  SEE ELEC. DATA	Ⓐ	MACHINE REQUIREMENTS 7.7 HP AT 13 LOAD AMPS ELECTRIC TANK HEAT 55 KW AT 66 LOAD AMPS Ⓑ ELECTRIC BOOSTER 32 KW AT 39 LOAD AMPS Ⓒ ELECTRIC BLOWER 25 KW +2HP AT 33 LOAD AMPS (STEPDOWN TRANSFORMER PROVIDES 120V CONT.)
②	HOT WATER (110°F)		3/4" NPT BOOSTER REQUIRES 158 GPH AT 20 PSI. (MAX. 60 PSI. TO MACHINE)
③	COLD WATER (65°F)		A. 1/2" NPT (CWT),(MAX 25PSI) TO MACHINE PRESSURE REDUCING VALVE TO BE SUPPLIED BY OTHERS WHEN CWT IS SPECIFIED B. 1/2" NPT FLUSHING NOZZLES AT 20 PSI.
④	HOT WATER (180°F)		3/4" NPT FINAL RINSE GPH AT 20 PSI. (PRV REQUIRED FOR HIGHER PRESSURE) (MAX. 60 PSI TO MACHINE)
⑤	DRAIN	Ⓐ	2" NPT MACHINE: LOAD END.
6			
7			
⑧	VENTS (3"X 23") INSIDE	Ⓐ	LOAD END: 300 CFM AT 1/4" S.P.
		Ⓑ	UNLOAD END: 800 CFM AT 1/4" S.P.

***This Page  
Intentionally  
Left Blank***

# Installation Instructions

1. The illustrations below are an example machine, your machine may be different.

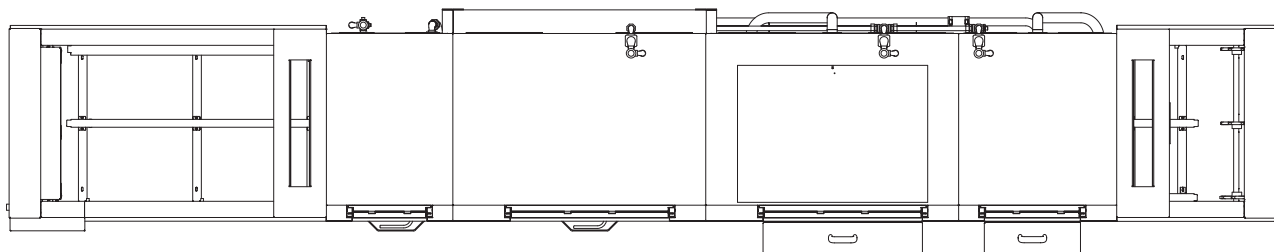

Plan View  
(machine viewed from above)

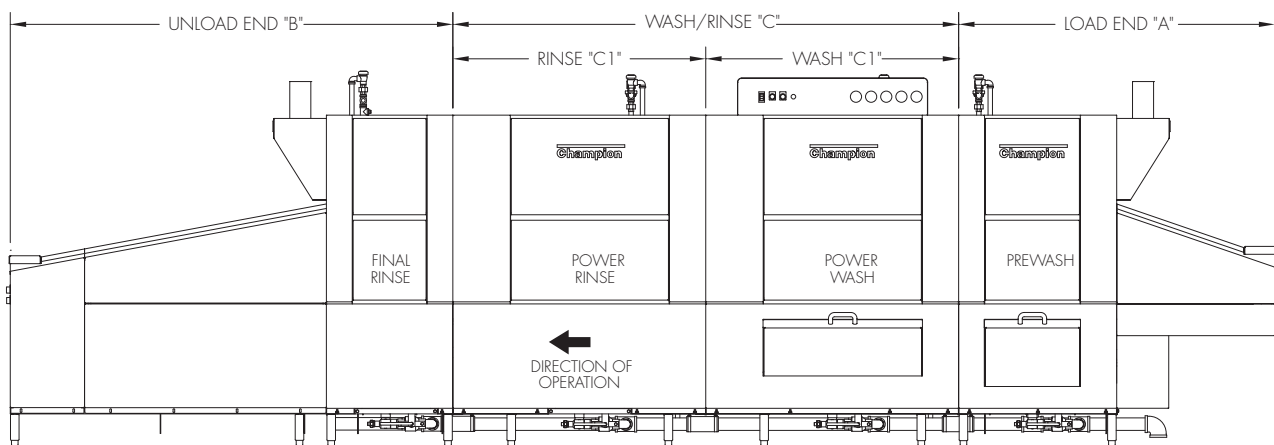

Elevation View  
(machine viewed from front)

# Installation Instructions

## Unpack and Place

### Unpack and place

1. Upright conveyor dishwashers ship in sections. Each section comes wrapped in a protective covering and secured to a wooden pallet. Labels note the total number of sections shipped, such as 1 of 4.

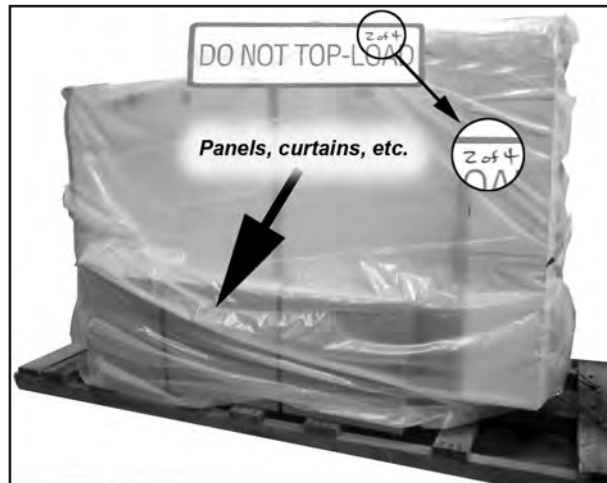

2. Check the shipment for damage immediately upon receipt. Save all packing materials and pallets, then contact a supervisor, the equipment dealer, and the factory to report the damage.
3. Fasteners, curtains, panels and other pieces are packing in cardboard boxes and secured to the wash/rinse section of the machine. Inventory these parts and report shortages to a supervisor, then store the parts in a secure location.

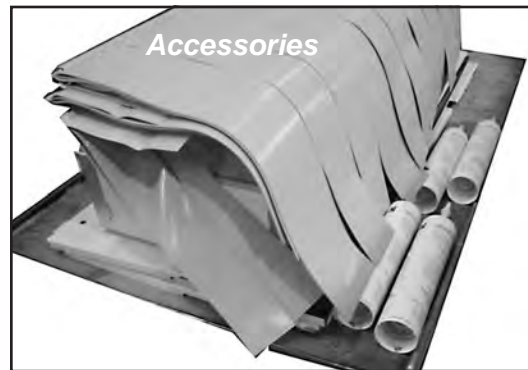

**CAUTION:**  
Standard 36" doorways often measure less than 35" in width.  
Shipping pallets measure 48" wide.

## Installation Instructions

Unpack and Place

4. Inspect the route that sections must travel if the shipment was not delivered to the dishwashing room. Measure all passageways and doors before moving the dishwasher.

**IMPORTANT**  
Check the utilities early  
Incorrect voltage, hot water supply,  
or steam piping may delay the  
completion of the installation

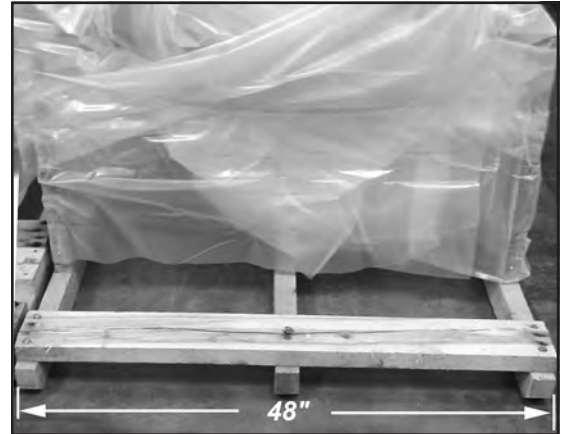

5. Piping on the rear wall of the dishwasher may be removed to allow the dishwasher to pass through narrow openings if necessary.
6. Compare the location of the site utilities with the **Plumbing and Electrical Connection Diagram, (P&E).**

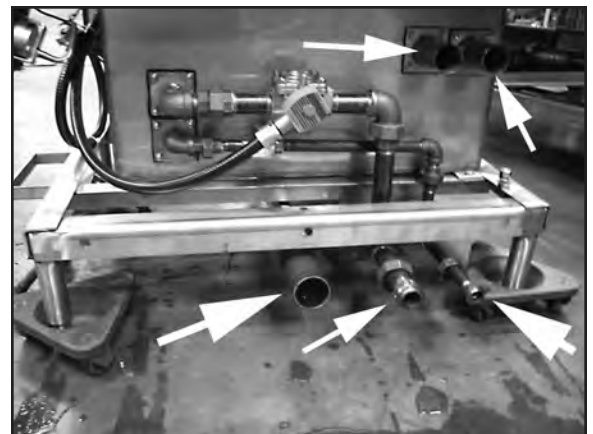

**CAUTION**  
Use extreme care when lifting  
a section off its pallet to prevent  
damage to the dishwasher.



## **Installation Instructions**

### *Order of Assembly*

7. Next, compare the site utilities with the utility connections on the dishwasher.

**The utility locations and ratings of the must match the dishwasher when it is re-assembled in its permanent location.**

**Contact a supervisor immediately if a utility location does not match the dishwasher.**

8. Check floor stability. Flooring must support the weight of the dishwasher without bowing when weight is applied.  
Tiled floors may fracture if loads are dropped on or drug across its surface.
9. Move the palletted sections near their permanent locations. Remove protective coverings, shipping straps, brackets and palletized accessories.
10. Inspect the underside of each section, (below the base) and note the position of piping, valves, and other components that may be in the way
11. Carefully lift each section off the pallet. Screw the adjustable bullet-feet in as far as possible, then lower the section to the finished floor.

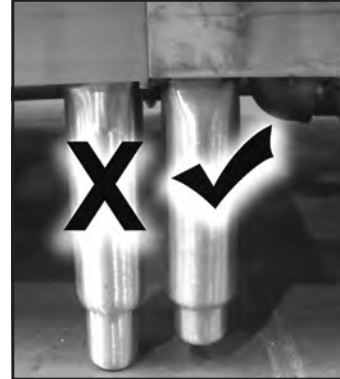

# Installation Instructions

## Order of Assembly

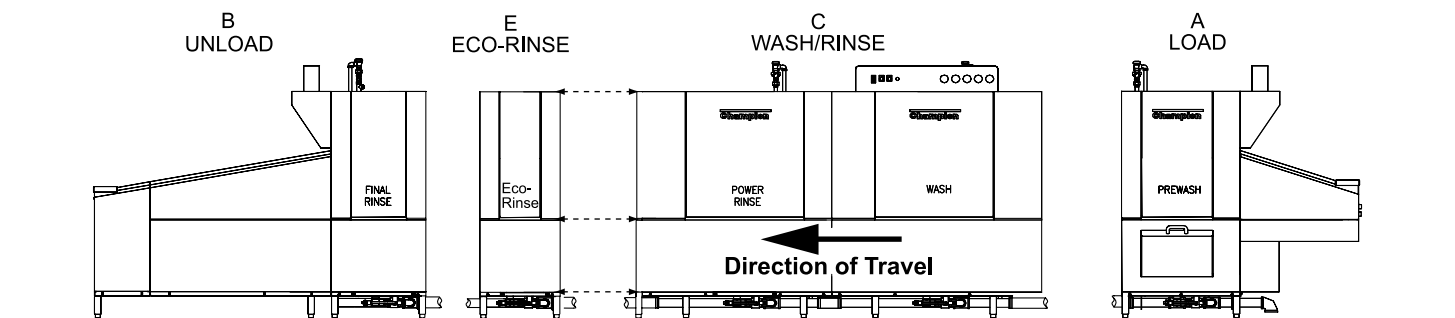

12. The illustration above shows the correct placement of the sections.
13. The recommended spacing between sections is 2 feet. Of course, the size of your dishroom dictates the actual section spacing.
14. Study the illustration above. Note that each section name also contains a designated letter, (A, B, C, E).
15. The illustrated dishwasher is a right-to-left, (R-L) configuration which indicates that soiled wares enter on the right and exit on the left. A left-to-right, (L-R), dishwasher is the reverse of a R-L dishwasher.
16. The "E" or Eco-rinse section is an option and may not be a part of your installation. The dashed lines between the "C" and "E" sections indicate that the "E" section usually ships as part of "C" section.
17. The "C" section ships as a single assy in 4, 6, or 8 ft. lengths.
18. The Order of Assembly should start with the "C" section; however, it is okay to start with the "B" section if the plumber is ready to make the hot water and steam connections.

## Installation Instructions

### Section Assembly

19. Remove the shipping braces from the sections.
20. Identify the location of piping between the sections.
21. Check the height of each section and determine which section is the highest due to floor variations.
22. Set the "C" section and adjust to its minimum height.
23. Level the "C" section side to side and front to back in several places with a bubble level.
24. The remaining sections are leveled in relation to "C" section. Do not adjust the "C" section too high.
25. Apply a 1/4" bead of FOOD GRADE sealant to the foam gaskets on each section.

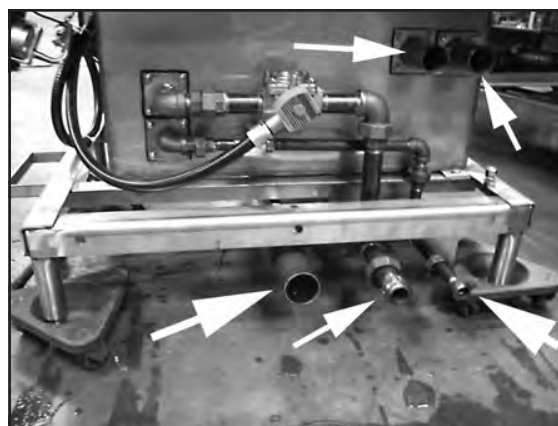

**APPROVED SEALANT WAS SUPPLIED IN THE HARDWARE KIT.**

**DO NOT SUBSTITUTE ANOTHER TYPE OF SEALANT.**

26. Move the next section close to the "C". Adjust the feet of this section to align the 20 bolt holes around the hood.
27. Slide the connecting hoses and clamps on drain pipes and cross-flow pipes. Do not tighten at this time.
28. Level each section side to side and front to back making sure the section connecting bolt holes align.

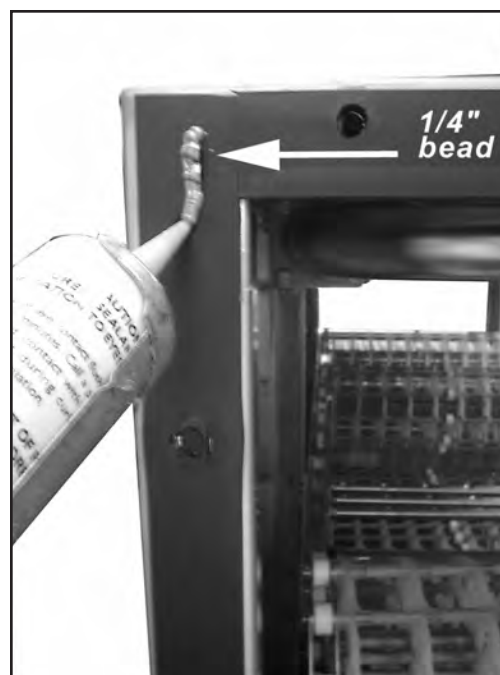

# Installation Instructions

## Section Assembly

- 29. Make sure the sections are adjusted to the same height.
- 30. Check the alignment of the conveyor tracks inside the machine and adjust tracks if necessary. Tracks should align if the sections are level.
- 31. Bolt all the HOOD sections together with twenty (20), 5/16-18 X 3/4" bolts, lockwashers and nuts included in the hardware kit.
- 32. Tighten the hood bolts in a cross-pattern to pull the sections together.
- 33. Silicon sealant should squeeze out of the section joints.
- 34. Apply a 1/2" bead of Foodgrade sealant in the bottom of the clip.
- 35. Invert the clip and slide it over the section joint
- 36. Bolt the clip securely in place.

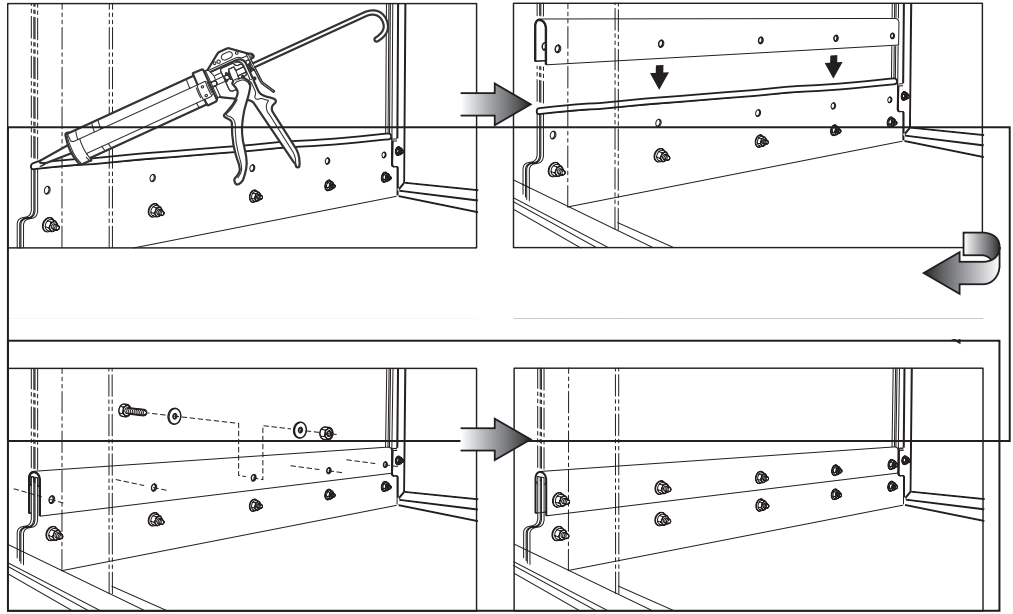
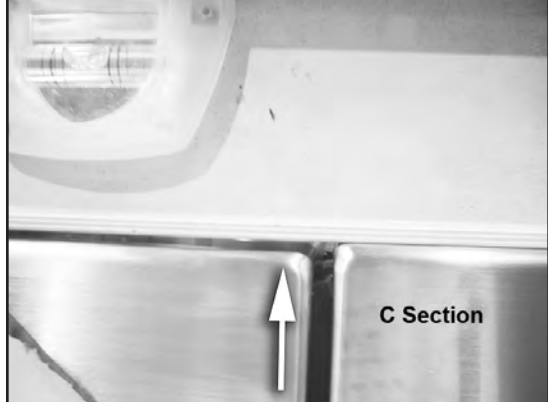

## Installation Instructions

### Conveyor Belt Installation

Beginning with S/N J11062899 and above

1. Remove the key from the conveyor drive sprocket.
2. Start at the unload end of the machine and pull the conveyor belt around the end sprockets until approximately 1.5 feet/76.2 cm of belt rests on the upper track of the dishwasher.
3. Pull a section of belt to the next section along the upper track into the unload end.
4. Join the belt sections together by feeding a conveyor rod through the links, spacers, and rollers. Install a cotter pin on each end of the rod to secure the assembly.
5. Use an assembled rod section on the belt as a guide for the placement of the spacers, etc., continue this procedure until the conveyor belt is assembled in a complete loop.

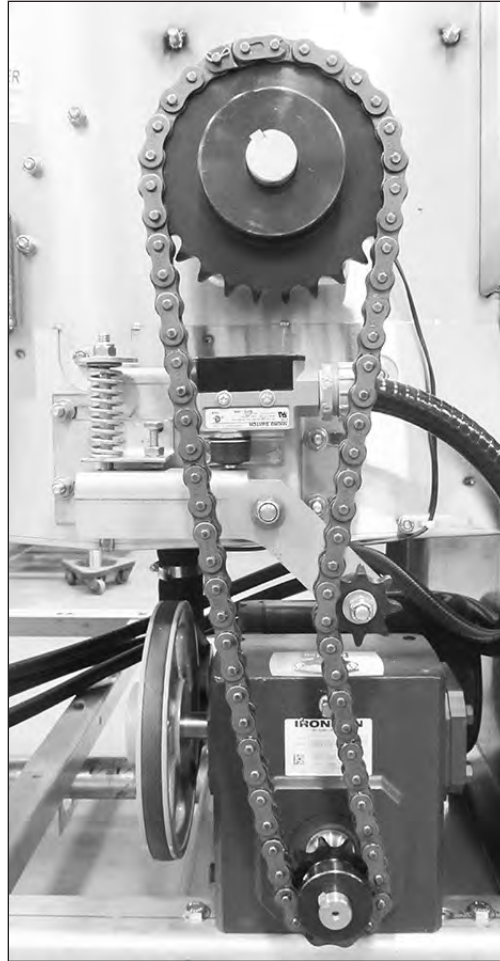

*Connect the conveyor belt sections with a rod, spacers, and washers included in the hardware kit.*

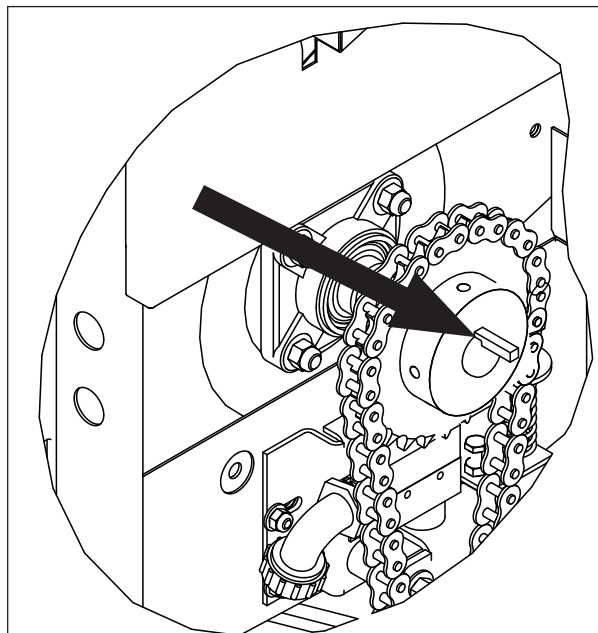

*Remove the key from the conveyor drive sprocket.*

## Conveyor Belt Installation

The take-up assemblies are located on either side of the load end conveyor shaft as shown in **(A)**.

Adjust the conveyor belt tension at the load end. Loosen the adjusting bolt locknuts then turn the adjusting bolts CW to tighten the belt.

Make sure the belt tension is even on both sides.

Check the slack of the lower portion of the belt. The lower belt must not sag.

Continue to adjust belt tension as you manually remove lower belt slack until the lower slack is minimized.

Check the belt tension by lifting the upper conveyor belt at the load end of the dishwasher as shown in **(B)**.

The proper belt tension is achieved when the top of the conveyor belt rods are even with the top of the belt access hole as shown in **(C)**.

**DO NOT OVERTIGHTEN THE BELT.**

Tighten the adjusting bolt locknuts on each take-up assembly to hold the belt adjustment.

Check that the conveyor belt tracks evenly on all of the conveyor drive sprockets during operation and adjust the take-up assemblies as required as shown in **(D)**.

Proper tracking requires that the rollers seat evenly in the conveyor belt drive sprockets. The metal links on the conveyor belt must not rub the sides of the belt sprockets as shown in **(E)**.

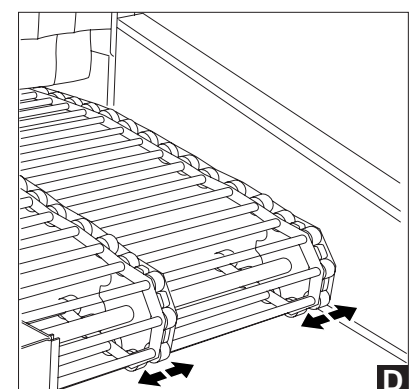
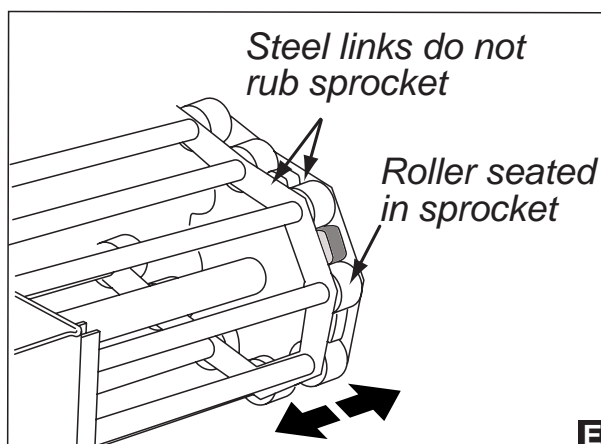
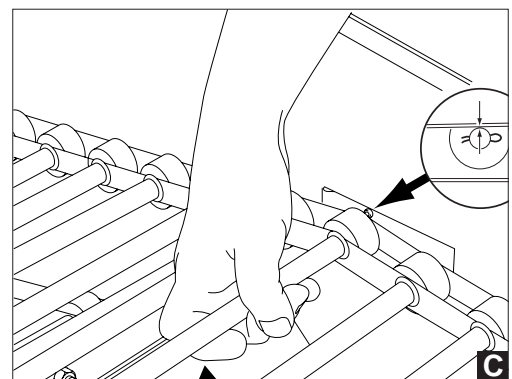
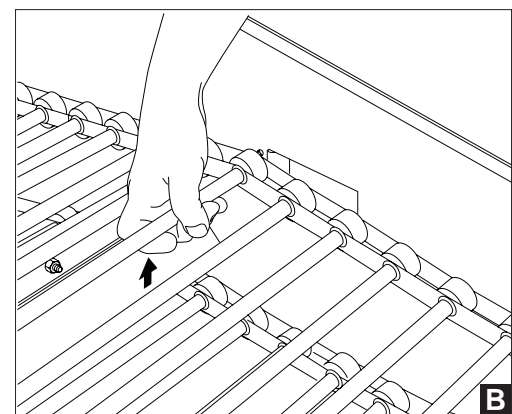
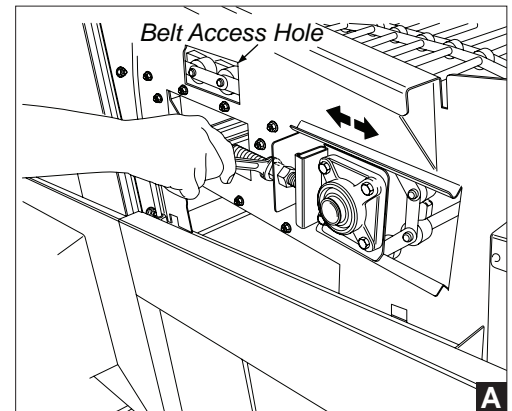

## **Installation Instructions**

### **Conveyor Drive**

Beginning with S/N J11062899 and above

There are two conveyor drive designs.

The first is the standard drive comprised of a gear box, drive belt motor and chain connected to the conveyor drive shaft.

The second design is variable speed solid-state electronic speed control, a variable speed motor and a chain connected to the conveyor drive shaft.

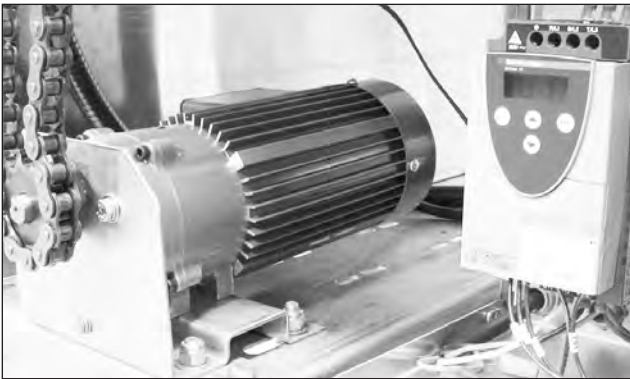

*Variable Frequency Drive (VFD) Conveyor Drive Motor*

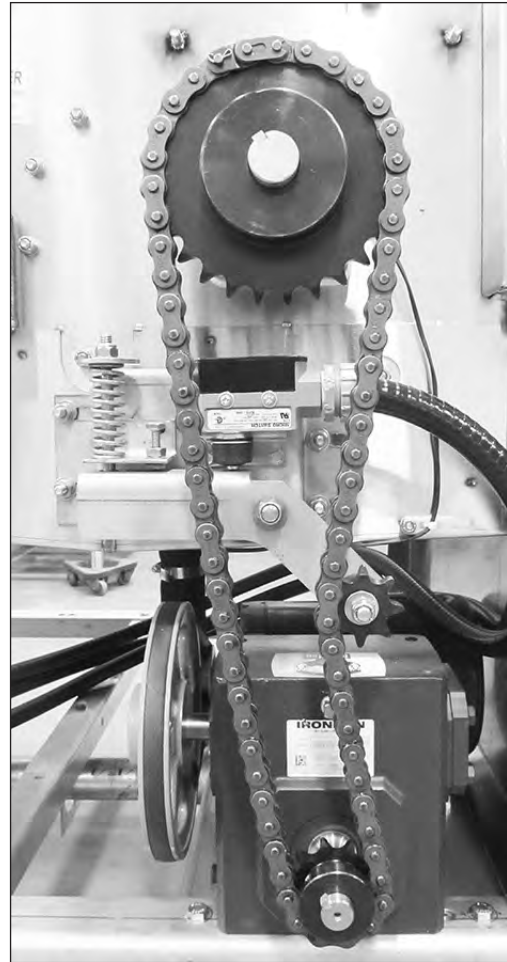

*Standard Single Speed Conveyor Drive*

The conveyor drive is equipped with anti-jam protection and a reversing switch if an object becomes jammed in the conveyor. This anti-jam mechanism shuts the conveyor drive off to prevent damage to the conveyor belt. The anti-jam switch is adjusted at the factory and should not require adjustment.

#### ***Anti-jam Swith Operation***

The anti-jam switch assembly consists of a base mounting bracket, a limit switch with a mounting bracket, and a spring loaded tensioner arm with a sprocket. A reverse jog switch button is always used in conjunction with the anti-jam switch. The tensioner arm with the sprocket is positioned on the drive side of the drive chain.

When a jam occurs, the drive chain tightens, causing it to straighten changing the position of the sprocket attached to the tensioner arm. When the sprocket position changes, the tensioner arm rotates away from the button on the anti-jam switch causing it to open.

When the switch opens, all power to drive motor is disconnected stopping the forward motion of the conveyor. The drive will not work in the forward direction as long as the anti-jam switch is in the open position.

## Reverse Jog Switch Operation

The Single Speed Reverse Jog operates under the following conditions:

- When the power is on and the anti-jam switch is open due to a conveyor jam.
- When the power is on and the conveyor was stopped via the "STOP". The "START" switch must be pressed to restart the forward motion of the conveyor.
- If the reverse jog switch is pressed while the conveyor is moving forward, the forward motion will stop as long as the switch is pressed. Releasing the switch will restart the belt forward motion.
- If the conveyor is stopped by the shut-off shelf, the "STOP" must be pressed before the reverse switch will work.

The VFD Reverse Jog operates under the following conditions:

- When the VFD is powered on regardless if the machine power is off.
- If the button is pressed when the conveyor is moving forward, the conveyor will run in reverse as long as the button is pressed; releasing the button returns the forward motion of the belt.
- When the anti-jam switch is open and the reverse button is pressed, the conveyor will run in reverse as long as the button is pressed. Releasing the button stops the conveyor. The START button must be pressed to restart the conveyor.
- The reverse button will work if the belt was stopped by the shut-off shelf.



Reverse Jog Switch

### Anti-Jam Switch Adjustments

The anti-jam switch has three adjustments. Refer to the letters in the photo at right:

- The base mounting bracket has horizontal slots for positioning the tensioner arm sprocket against the drive chain. This is a factory setting and should not require changing.
- The limit switch bracket has vertical slots to adjust the switch up and down. Raising the switch reduces the switch reaction time, lowering it increases the reaction time.
- The tensioner arm spring sets the amount of force required to operate the jam switch. The tighter the spring the more load it takes to operate the switch and stop the conveyor.

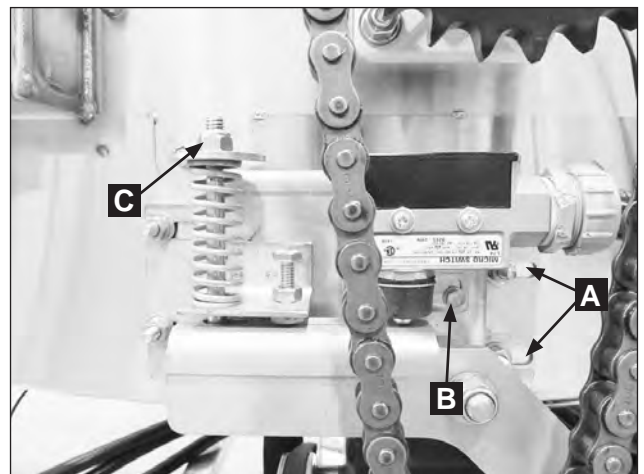

Anti-jam Switch

## Installation Instructions

### Section Assembly

21. The Installation Supervisor must inspect the position, level and proper connection of the piping connections.

22. Steam supply and condensate unions must be tight.

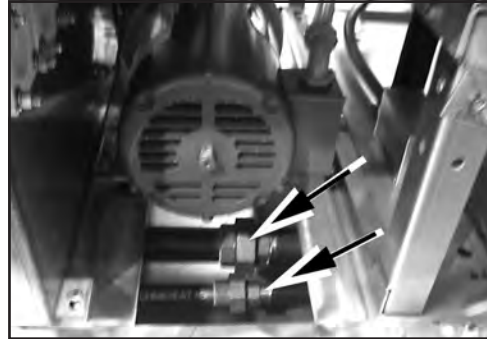

23. Drain piping must be checked.

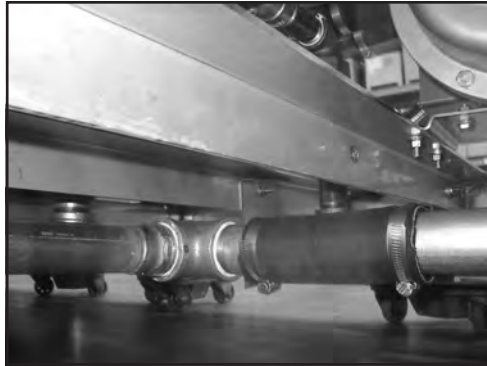

24. Cross-flow hoses must be inspected and clamps tightened.

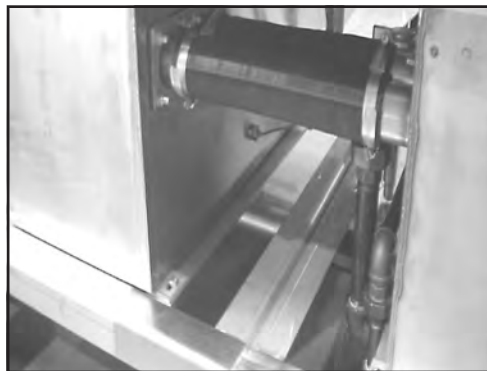

25. Flushing nozzle piping on the load end must be inspected.

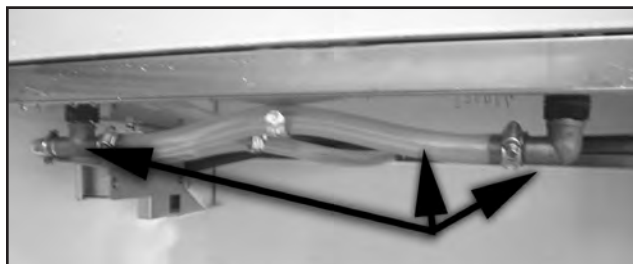

# Installation Instructions

## Section Assembly

26. Check and tighten the fill piping compression fittings.
27. Make sure solenoid coils are positioned correctly on the valve assemblies.
28. Vent stacks must be placed on the hood with vent handles facing the front of the dishwasher.
29. Panels must be rechecked for missing parts, and the location numbers checked with the numbers located on the dishwasher.
30. Tanks must be checked for debris and metal tailings must be vacuumed out of the machine.
31. Curtains must be installed. Install the curtains. Long curtains hang in hooks on each end of the machine. Short curtains hang in hooks on the inside of the machine.
32. Scrap screens, scrap baskets must be checked and installed in the dishwasher.

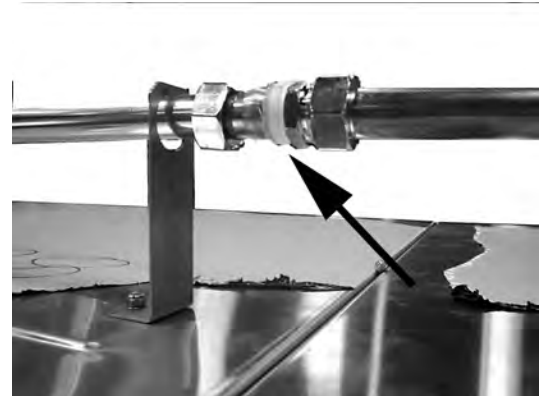

## **Installation Instructions**

### **Optional Blower Dryer Assembly**

1. The blower dryer comes in electric or steam.
2. It ships on a separate pallet.  
The vent cowl and mounting hardware are included in the accessories box and hardware kit.
3. Lift the blower dryer off the pallet with a forklift and place on the end of the unload section.  
  
If a forklift is not available, then four (4) men are needed to lift and install the unit manually.
4. Bolt the blower dryer in place using the 5/16-18 X 3/4" bolts, flat washers, and lock washers from the hardware kit.
5. Fasten the vent cowl on the discharge end of the blower dryer using the 1/4-20 plain nuts, flat washers, and lock washers from the hardware kit.
6. Connect the flex-tite conduit to the junction box located at the rear of the dishwasher.
7. Match wire numbers in the junction box and connect with wire nuts.
8. Close the junction box.
9. Install the cowl to the end of the blower dryer.

**REFER TO THE BLOWER-  
DRYER SERVICE MANUAL  
P/N 114316**

**SHIPPED WITH THE  
BLOWER-DRYER  
ASSEMBLY**

**FOR COMPLETE  
INSTALLATION  
INSTRUCTIONS.**



# Installation Instructions

## Connect the dishwasher internal electric wiring

1. Wires, flex-tite, and some components were disconnected and pulled back to each section, then junction boxes were closed.
2. Open all junction boxes, identify the flex-tite conduit connections, (A) roll-out wire bundles, (B), and match wire numbers attached on wires, (C).
3. Connect the flex-tite conduit to their associated junction boxes.
4. Connect matching wires using the supplied wire nut connectors, (D) included in the hardware kit.
5. Connect #2 and any white wires together. All of these wires are neutral returns.
6. Close all junction boxes.

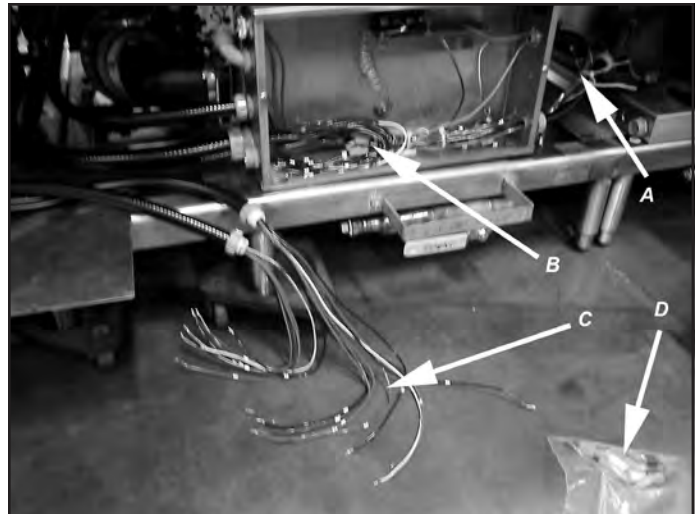

## **Installation Instructions**

### *Section Assembly - Seal Joint Sections*

1. Section joints must be sealed with foodgrade silicon sealant.
2. Mask the joint edges with a quick-release masking tape.
3. Apply a 1/8" bead of Foodgrade silicon sealant. Apply moderate pressure on the gun to ensure the sealant fills the joint.
4. Wait 45-seconds for the sealant to firm slightly. Then wipe the joint with a damp cloth.

Do not wait longer than 1 minute for the sealant to firm. The sealant will not wipe correctly.

5. If the sealant dries longer than 1 minute, DO NOT try to wipe the joint. Allow the sealant 30 minutes to dry, then cut the sealant out of the joint and begin again.
6. Wait 10-seconds after wiping the joint, then remove the masking tape.

7. Continue sealing the joints.  
DO NOT SEAL more than one joint at a time. The sealant will dry faster than you can work the joint.

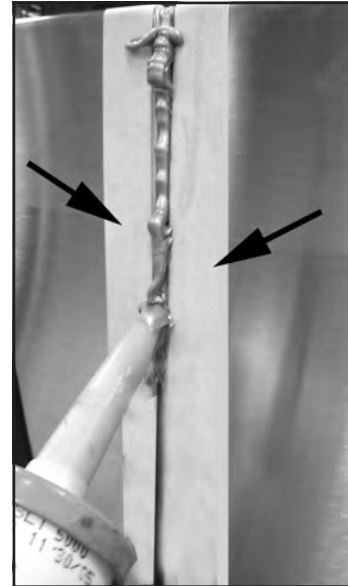

## **Installation Instructions**

### *Section Assembly - Seal Joint Sections*

8. Study the photos on the right. The top photo shows a correctly sealed joint.

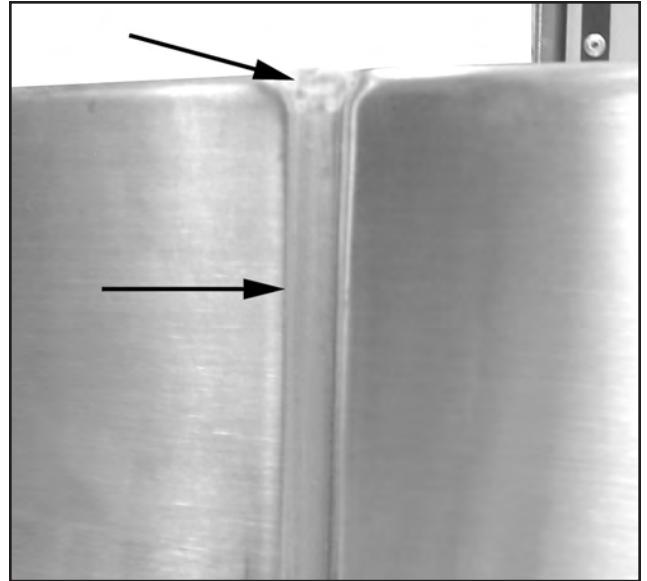

9. The stainless steel must be wiped with Isopropyl alcohol to remove dust, oil film, and other contaminants.

10. Note that the joint is filled presenting an even transition between sections.

11. The sealant is applied past the top radius of the joint presenting a uniform fill.

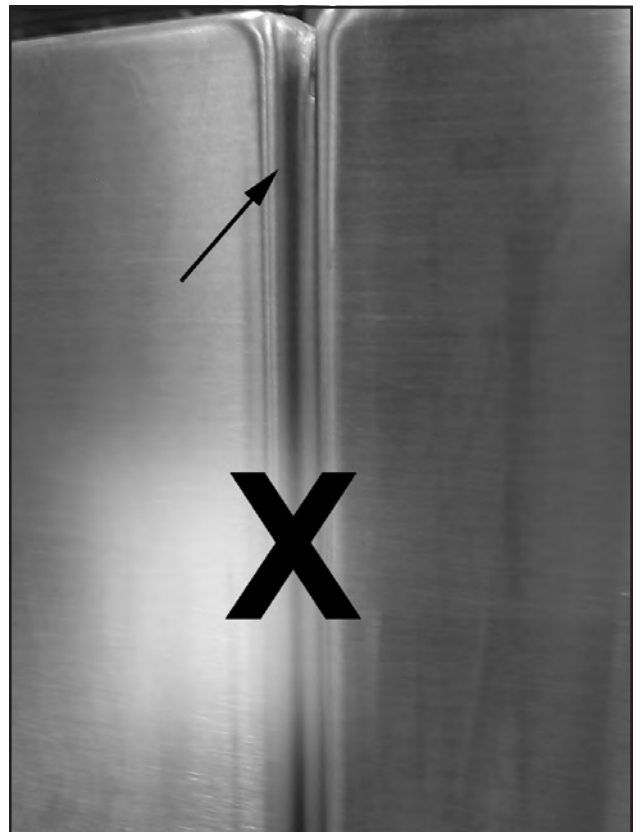

12. Study the lower sealed joint. This joint did not have enough sealant applied and therefore presents a crevasse where soils may be trapped.

13. Practice this procedure on a hidden joint if you experience problems with the procedure.

## Installation Instructions

### Supply Connections - Main Incoming Power

The Main incoming power to the dishwasher is made at the top of machine in the control cabinet.

The electrician must connect the power supply in accordance with the data stamped on the Machine Electrical Connection Plate.

This data is the ultimate authority and is not superseded by any other data supplied in print, or conveyed verbally.

**WARNING:**

Electrical and grounding connections must comply with the National Electrical Code and/or Local Electrical Codes.

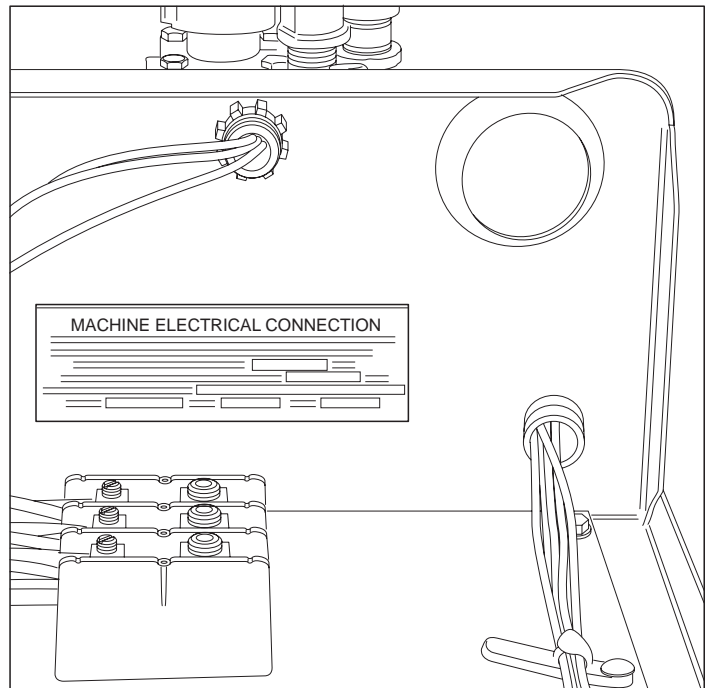

**WARNING:**

When working on the dishwasher, disconnect the electric service and place a tag at the disconnect switch to indicate work is being done on that circuit.

**Note:**

A qualified electrician must compare the electrical power supply with the machine electrical specifications stamped on the MACHINE ELECTRICAL CONNECTION PLATE located inside the control cabinet before connecting to the incoming service at a fused disconnect switch.

## **Installation Instructions**

### **Supply Connections - Water and Steam**

#### **IMPORTANT**

**Main utility supply connections must be performed by licenced tradesmen who abide by local building, health and sanitation codes or national codes in the absence of local codes.**

**THE MAIN INCOMING HOT WATER AND STEAM SUPPLY CONNECTIONS ARE MADE IN THE LOWER PART OF "D" SECTION**



**Hot water connection**

**ATTENTION INSTALLERS AND SUPERVISORS**

**REFER TO THE PLUMBING & ELECTRICAL CONNECTION DIAGRAM FOR THE LOCATION AND SIZE OF ALL UTILITIES.**



**Steam and condensate connection**

**BUILDING VENTILATION CONNECTIONS ARE MADE AT THE TOP OF THE "A" AND "D" SECTIONS.**

**BUILDING VENTS MUST ALIGN WITH THE DISHWASHER CENTER-LINE AND MATCH THE SIZE OF THE DISHWASHER VENT DUCTS.**

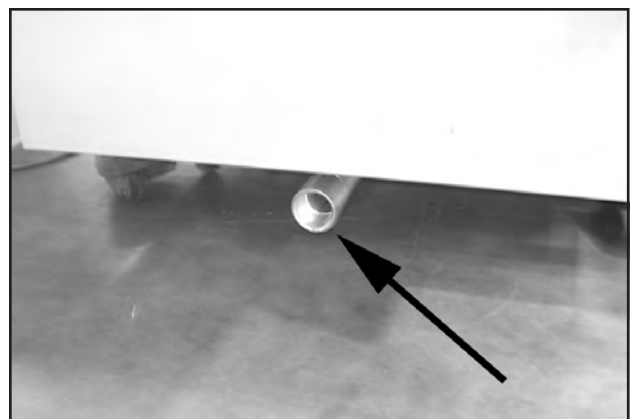

**Drain Connection**

# Installation Instructions

## Supply Connections - Chemical Dispensers

Chemical dispensing systems are supplied by others.

A connection point for detergent, and rinse-aid signals is provided in the in the top-mounted control cabinet.

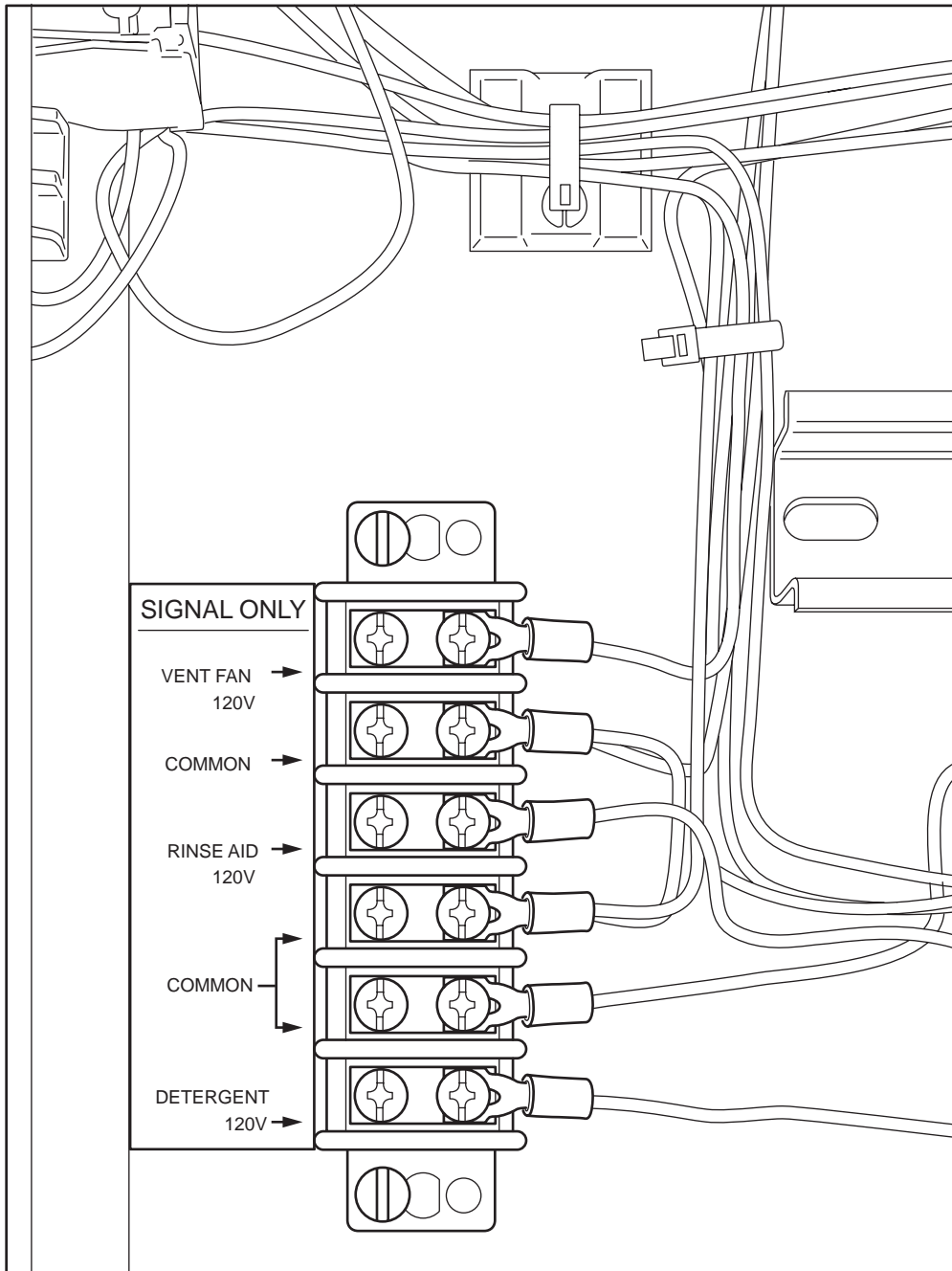

# **Installation Instructions**

## **Initial Start-up**

Perform the following checks and adjustments before placing the machine into service.

- Check the interior of the machine and remove any foreign material.
- Check the exterior of the machine — make sure that the conveyor belt is free of tape and foreign material.

### **Baffles –**

Tank baffles redirect the flow of water from the spray arm systems back into the tanks. This prevents water loss and keeps the wash, rinse, and final rinse water in the proper tank. Check the baffles — make sure that they are installed and positioned correctly.

Close the tank drain valves along the lower front of the machine.

Open the water supply valves. Check for leaks and take corrective action as required.

Open the steam supply valves (if applicable). Check for leaks and take corrective action if required.

Turn the main power on at the breaker panel or fused disconnect switch.

Machine main power

Electric booster main power (if applicable)

Flip the Power Switch on the front of the Control Cabinet to the "ON" position.

The Red power on light will illuminate.

The machine will begin to fill with water.

Allow the machine to completely fill with water.

The water will shut off automatically.

Check for leaks and take corrective action if required.

Monitor the tank thermometers for the proper temperature reading.

Allow sufficient time for the tank heat to reach operating temperature.

Move the conveyor shut-off shelf located at the end of the unload section toward the machine. This resets the automatic conveyor stop system.

When an object on the conveyor contacts the shut-off shelf, the conveyor stops.

Press the GREEN start button on the front of the control cabinet.

## ***Installation Instructions***

### ***Initial Start-up***

Check the direction of rotation of the conveyor belt by observing the direction arrow decal on the large conveyor drive sprocket. The sprocket is located on the side of the unload section.

If rotation direction is incorrect, reverse wires L1 and L2 on the disconnect switch side of the main electrical connection terminal block located inside the control cabinet.

Each temperature gauge is marked with its proper operating range.

Check the Energy Sentinel (idle pump shut-off) by placing a tray or dish on the moving conveyor belt.

The pumps will start as the object enters the tunnel of the machine.

The optional econo-rinse pump starts with the final rinse.

Check pump motor rotation, CW when viewed from the rear of motor.

Check the final rinse temperature as the object enters the final rinse area.

The Final rinse temperature must be 180-195°F.

Adjust the temperature of the incoming water supply if necessary.

Adjust the booster thermostat setting if necessary.

Check the Final rinse water pressure as the object enters the final rinse area.

The final rinse pressure must be 20-22 PSI.

Adjust the Pressure Reducing Valve setting if necessary.

Check that the pumps and final rinse shut-off before the object reaches the conveyor shut-off shelf.

Check that the conveyor belt stops when the object pushes the conveyor shut-off shelf.

Move the shut-off shelf toward the tunnel of the machine. The conveyor belt will start moving again.

Push the RED stop button. The conveyor belt will stop moving.

Flip the power switch on the control cabinet to OFF. The red power light will go out.

Open all the drain valves and check that the house drains can handle the flow.

Remove any protective film from the stainless steel and install the side panels and chain guard.

Check the curtains for correct placement in the machine.

Be sure the short flaps of the Long Curtains face the load end of the machine.

Check the spray pipes.

Be sure the spray pipe gasket is installed on the end of spray pipe before installing.

Spray pipes are installed by inserting the pipe into the coupler and turning 1/4 turn clockwise.

Check the scrap screens.

Install any scrap basket covers.

Check that the conveyor shut-off shelf is pushed toward the machine tunnel.

Close the drain valves, located under the base of each tank.

When the drain handle is horizontal, the valve is open.

When the valve handle is vertical, the valve is closed

Check the detergent and rinse aid supplies (supplied by others).

***This Page  
Intentionally  
Left Blank***



