

Champion®

The Dishwashing Machine Specialists

Project _____
Item No. _____
Quantity _____

DH6000T HOOD-TYPE

STANDARD FEATURES

- **Factory Authorized Startup**
- **HMI – Operator Touch Screen Interface**
- **On-board Service Diagnostics**
- **Field Convertible – Single to three, or three to single phase**
- **Sleep Mode – All internal heaters shut off after 4 hours idle**
- Built-in booster configured to ensure 180° rinse
- Field convertible from straight to corner operation
- Dual NSF listed as both a dishwasher and potwasher
- Rinse Sentry – ensures 180°F final rinse
- Auto start – starts unit when hood is closed
- Single point electrical connection
- High efficiency 2 HP pump
- Self draining pump
- Automatic tank fill
- Automatic drain valve – drains wash tank when power is off
- PRV (Mounted Pressure Reducing Valve)
- 4 selectable cycles
- Vent fan control
- 27" [686mm] extended clearance

OPTIONS & ACCESSORIES

- NEW** Built in detergent and rinse aid pumps
- Two point electrical connection (field installed)
- Drain Water Tempering Kit (unmounted)
- Door interlock – locks door closed during the vent fan cycle
- Single phase option
- Racks
 - Peg
 - Flat
 - Sheet Pan rack
- Corner operation splash baffle
- NEW** Champion ION scale prevention system (unmounted)

DH6000T

DH6000T High Temperature Hood-type Dishwashing Machine



Photo is for general visual representation only. Please refer to specifications for the latest detailed product information.

SPECIFIER STATEMENT

Specified unit will be Champion model DH6000T high temperature, high-hood type dishwashing machine.

Features, electronic controls, Rinse Sentry, Auto start, interchangeable stainless steel wash and rinse arms, up to 60 racks/hr, 0.73 US gals [2.76 liters, 0.61 imp. gals]/rack.

1 year parts and labor warranty.

Champion Industries, Inc.
3765 Champion Blvd., Winston-Salem, NC 27105
Tel: 336/661-1556 Fax: 336/661-1979
www.championindustries.com

Champion®

The Dishwashing Machine Specialists

DH6000T

DH6000T High Temperature Hood-type Dishwashing Machine

Shipping weight crated: 300 lbs.

Dimensions shown in inches and [mm]

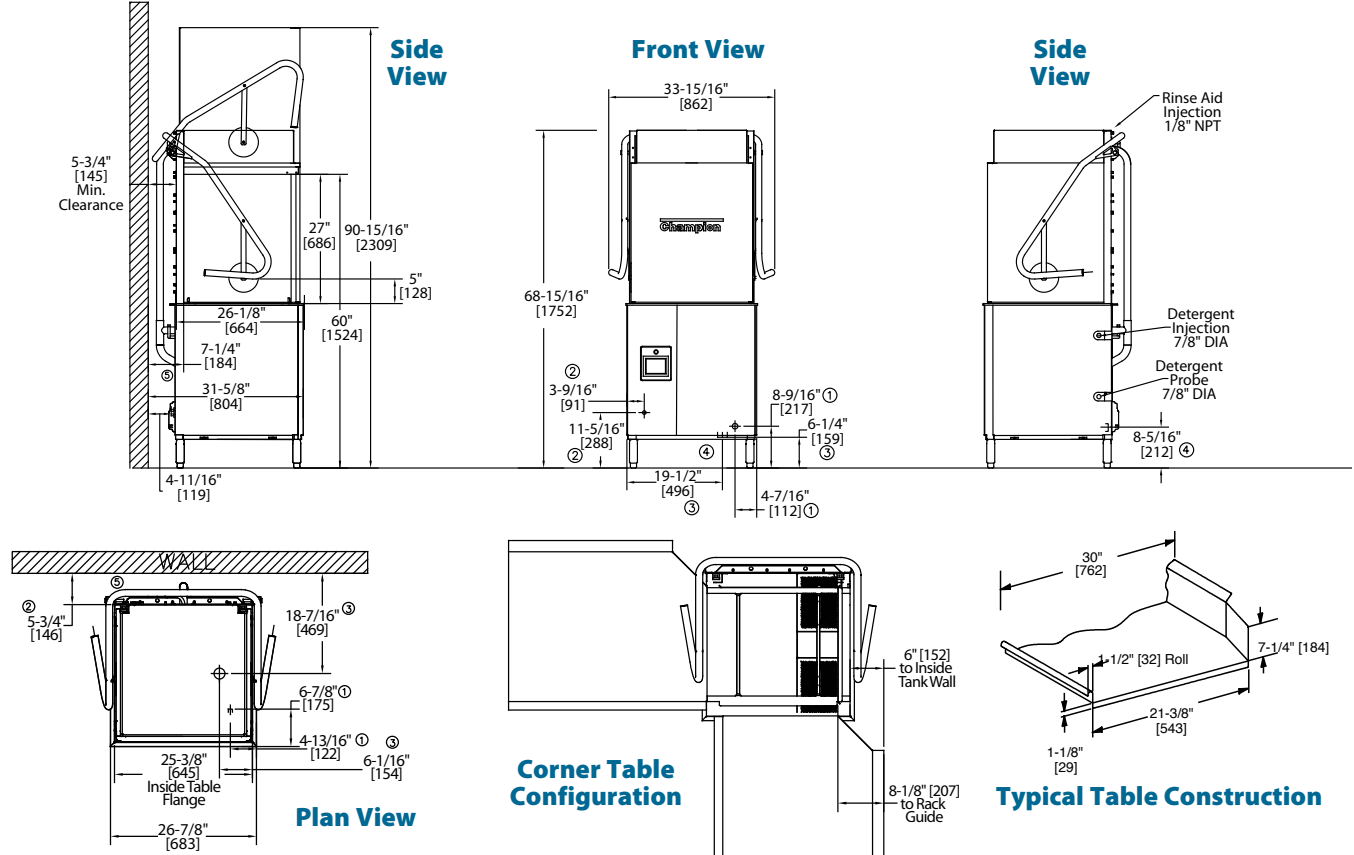

UTILITIES	
1	Electrical Machine Connection (See Electrical Box)
2	Hot Water 3/4" NPT Hot Water 110° - 140°F 20-22 PSI Flow Pressure
3	Drain 1.5" OD Connection; 15 GPM Max Flow (Drain water tempering height 5")
4	Drain Water Tempering 1/2" Cold water line with customer supplied cut-off valve (optional)
5	Integrated Detergent System Detergent bottle supply connections (optional)

Warning: Plumbing, electrical connections should be made by qualified personnel who will observe all the applicable plumbing, sanitary and safety codes and the National Electrical Code.

Note: Optional Drain Tempering: 1/2" NPT cold water connection required. 1/2" NPT drain connection from back flow preventer to house drain. (FIELD INSTALLED and PLUMBED).

Due to an ongoing value analysis program at Champion, specifications contained in this catalog are subject to change without notice.

Champion Industries, Inc.,
3765 Champion Blvd., NC 27105
336/661-1556 • Fax: 336/661-1979
ChampionIndustries.com

Machine & Built-in Booster (Standard)			
Voltage	Rated Amps	Minimum Supply Circuit Ampacity	Maximum Overcurrent Protective Device
208-240/60/1	77-68	100	100
208-240/60/3	46-41	60	60
480/60/3	20	30	30

Machine Only (two point electrical connection or no built-in booster)			
Voltage	Rated Amps	Minimum Supply Circuit Ampacity	Maximum Overcurrent Protective Device
208-240/60/1	38-34	50	50
208-240/60/3	25-23	30	30
480/60/3	11	15	15

Booster Only (two point electrical connection)			
Voltage	Rated Amps	Minimum Supply Circuit Ampacity	Maximum Overcurrent Protective Device
208-240/60/1	39-34	50	50
208-240/60/3	21-18	25	25
480/60/3	9	15	15

Note: Water Hammer Arrestor (meeting ASSE-1010 standard or equivalent) to be supplied (by others) in common water supply line at service connection.

SPECIFICATIONS				
Capacities				
Racks per hr. (NSF rated)	60			
Wash tank (gal.)	10			
Motor horsepower				
	2 HP			
Water consumption				
Gal. per hr. (max. use)	39			
Gal. per rack	0.73			
Temperature °F				
Wash	150			
Rinse	180			
Heating				
Tank heat, electric	5.2 kW			
Electric Booster	7.5 kW			
	Dish-washer Mode	Pot & Pan Mode		
Selectable cycle times in minutes	1	2	4	6
Time cycles in seconds				
Wash	36	94	214	334
Rinse	8	10	10	10
Sanitary Dwell	16	16	16	16
Total	60	120	240	360