

# Champion®

## Installation/Operation with Service Replacement Parts

Beginning with Serial No. J2089 and above



*EUCCW-8 / EUCC-8*



*EUCCW-6 / EUCC-6*



*EUCCW-4 / EUCC-4*

### Eseries High Temperature Upright Conveyor Dishwasher

Models:

**EUCCW** 29" wide conveyor with a 4', 6', or 8' center section

**EUCC** 24" wide conveyor with a 4', 6', or 8' center section



[www.championindustries.com](http://www.championindustries.com)

Issue Date: 5.6.19

**Manual P/N 114254 rev. J**

For machines beginning with S/N J2089 and above

3765 Champion Boulevard,  
Winston-Salem, NC 27105  
336/661-1556 Fax: 336/661-1660  
Toll-free: 800.858.4477

2674 N. Service Road, Jordan Station  
Ontario, Canada L0R 1S0  
905/562-4195 Fax: 905/562-4618  
Toll-free: 800.263.5798

Printed in USA



**ATTENTION:**

The dishwasher model no., serial no., voltage, Hz and phase are needed to identify your machine and to answer questions.

Please have this information on-hand if you call for service assistance.



For all models:

The data plate mounts to one side of the top-mounted control cabinet.

**National Service Department**

**In Canada:**

Toll-free: 800/ 263-5798  
Tel: 905/ 562-4195  
Fax: 905/ 562-4618  
email: [service@moyerdiebellimited.com](mailto:service@moyerdiebellimited.com)

**In the USA:**

Toll-free: 800/ 858-4477  
Tel: 336/ 661-1556  
Fax: 336/ 661-1660  
email: [service@championindustries.com](mailto:service@championindustries.com)

# **Two ways to REGISTER YOUR PRODUCT and ACTIVATE YOUR WARRANTY.**

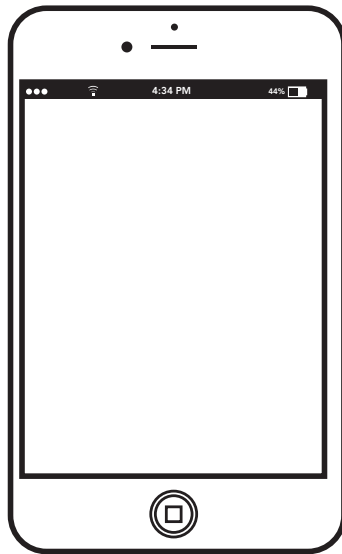

- Use your mobile or computer to go to our website at [www.championindustries.com](http://www.championindustries.com) and register your product there.
- Use the fax form on the next page.

# PRODUCT REGISTRATION BY FAX

**COMPLETE THIS FORM AND FAX TO:**

**(336) 661-1660 in the USA**

**1-(800) 204-0109 in Canada**

## PRODUCT REGISTRATION CARD

Model
-------

Serial #
----------

Date of Installation: \_\_\_/\_\_\_/\_\_\_

Company Name: \_\_\_\_\_

Address: \_\_\_\_\_  
(Street) Province Postal Code

Telephone #: ( ) \_\_\_\_\_ --- \_\_\_\_\_

Contact: \_\_\_\_\_

Installation Company: \_\_\_\_\_

Address: \_\_\_\_\_

Telephone #: \_\_\_\_\_

Contact: \_\_\_\_\_

**FAILURE TO REGISTER YOUR PRODUCT MAY VOID YOUR WARRANTY**

**IMPORTANT IMPORTANT**



## Revision History

<b>Revision Date</b>	<b>Revised Pages</b>	<b>Serial Number Effectivity</b>	<b>Revision Description</b>
3.16.07	All	J2089	Issue of First Edition
3.22.07	All	J2089	Revised Parts Format
7.27.07	All	J2089	Added 575VAC Parts
11.18.08	All	J08102541	Added Digital Display
10.5.09	All	-----	Changed P/N's for Clutch
12.6.09	63-71	J09062644	Added Standpipe Gasket
1.6.10	181,183	J09062644	Corrected P/N's 45, 46, 47
2.10.10	92,94,102	J09062644	Changed 1/4" plug to 1/8" plug for rinse injector
2.10.10	176-183	J10012728	Updated P/N's and added new control cabinet layout
8.10.10	114,116,120 124, 128,130	J10012728	Changed 1" Steam to P/N 114800
8.25.10	104-105, 108-109	J09062644	3/4" solenoid valve changed to 1/2"
8.25.10	166-170	-----	Added EUCC belts
8.25.10	204-208	J09062644	Added swing-out doors
5.2.11	194, 198	J08102541	Corrected Item 35 P/N from 111980 to 114505
2.28.17	30-33	J11062899	Changed clutch to anti-jam switch design added VFD drive.
	211-220	J11062899	Updated parts lists and electrical schematics
5.6.19	12	-----	Updated thermometer photo.
	190-198	All	Updated fuse blocks and J type fuse to T

Dear Owner:

Thank-you for choosing our dishwasher.

We appreciate your business.

This manual covers two models:

EUCCW      Electric high temperature flight-type conveyor dishwasher with built-in  
EUCC      electric booster in 40° F/22° C rise or an optional 70° F/39° C rise booster.

EUCCW      Steam high temperature flight-type conveyor dishwasher with built-in  
EUCC      steam booster in 40° F/22° C rise or an optional 70° F/39° C rise booster.

*The installation, and initial start-up of your dishwasher must be performed by qualified electricians, plumbers, and authorized service technicians trained in commercial dishwashers.*

*Defects and repairs caused by unauthorized installers will not be covered by the dishwasher warranty.*

# **Table of Contents**

## **E series Upright Conveyor Dishwashers**

Revision History _____	<i>i</i>
Limited Warranty _____	<i>iv</i>
<b>Operating Instructions</b> _____	<b>1</b>
Construction	
How to Operate your Dishwasher	
Cleaning and Maintenance	
Troubleshooting	
<b>Installation</b> _____	<b>21</b>
The plumbing and electrical connection diagram, (P&E).	
Unpack and Place	
Order of Assembly	
Section Assembly	
Water Connection	
Drain Connection	
Electrical Connection	
Ventilation	
Initial Start-up	
<b>Service Replacement Parts</b> _____	<b>47</b>
<b>Electrical Schematics</b> _____	<b>217</b>

## LIMITED WARRANTY

Champion Industries Inc. (herein referred to as Champion), 3765 Champion Blvd, Winston-Salem, North Carolina 27105, and P.O. Box 301, 2674 N. Service Road, Jordan Station, Canada, L0R 1S0, warrants machines, and parts, as set out below.

**Warranty of Machines:** Champion warrants all new machines of its manufacture bearing the name "Champion" and installed within the United States and Canada to be free from defects in material and workmanship for a period of one (1) year after the date of installation or fifteen (15) months after the date of shipment by Champion, whichever occurs first. [See below for special provisions relating to glasswashers.] The warranty registration card must be returned to Champion within ten (10) days after installation. If warranty card is not returned to Champion within such period, the warranty will expire after one year from the date of shipment.

Champion will not assume any responsibility for extra costs for installation in any area where there are jurisdictional problems with local trades or unions.

If a defect in workmanship or material is found to exist within the warranty period, Champion, at its election, will either repair or replace the defective machine or accept return of the machine for full credit; provided; however, as to glasswashers, Champion's obligation with respect to labor associated with any repairs shall end (a) 120 days after shipment, or (b) 90 days after installation, whichever occurs first. In the event that Champion elects to repair, the labor and work to be performed in connection with the warranty shall be done during regular working hours by a Champion authorized service technician. Defective parts become the property of Champion. Use of replacement parts not authorized by Champion will relieve Champion of all further liability in connection with its warranty. In no event will Champion's warranty obligation exceed Champion's charge for the machine. The following are not covered by Champion's warranty:

- a. Lighting of gas pilots or burners.
- b. Cleaning of gas lines.
- c. Replacement of fuses or resetting of overload breakers.
- d. Adjustment of thermostats.
- e. Adjustment of clutches.
- f. Opening or closing of utility supply valves or switching of electrical supply current.
- g. Cleaning of valves, strainers, screens, nozzles, or spray pipes.
- h. Performance of regular maintenance and cleaning as outlined in operator's guide.
- i. Damages resulting from water conditions, accidents, alterations, improper use, abuse, tampering, improper installation, or failure to follow maintenance and operation procedures.
- j. Wear on Pulper cutter blocks, pulse vanes, and auger brush.

*Examples of the defects not covered by warranty include, but are not limited to:* (1) Damage to the exterior or interior finish as a result of the above, (2) Use with utility service other than that designated on the rating plate, (3) Improper connection to utility service, (4) Inadequate or excessive water pressure, (5) Corrosion from chemicals dispensed in excess of recommended concentrations, (6) Failure of electrical components due to connection of chemical dispensing equipment installed by others, (7) Leaks or damage resulting from such leaks caused by the installer, including those at machine table connections or by connection of chemical dispensing equipment installed by others, (8) Failure to comply with local building codes, (9) Damage caused by labor dispute.

**Warranty of Parts:** Champion warrants all new machine parts produced or authorized by Champion to be free from defects in material and workmanship for a period of 90 days from date of invoice. If any defect in material and workmanship is found to exist within the warranty period Champion will replace the defective part without charge.

**DISCLAIMER OF WARRANTIES AND LIMITATIONS OF LIABILITY. CHAMPION'S WARRANTY IS ONLY TO THE EXTENT REFLECTED ABOVE. CHAMPION MAKES NO OTHER WARRANTIES, EXPRESS OR IMPLIED, INCLUDING, BUT NOT LIMITED, TO ANY WARRANTY OF MERCHANTABILITY, OR FITNESS OF PURPOSE. CHAMPION SHALL NOT BE LIABLE FOR INCIDENTAL OR CONSEQUENTIAL DAMAGES. THE REMEDIES SET OUT ABOVE ARE THE EXCLUSIVE REMEDIES FOR ANY DEFECTS FOUND TO EXIST IN CHAMPION DISHWASHING MACHINES AND CHAMPION PARTS, AND ALL OTHER REMEDIES ARE EXCLUDED, INCLUDING ANY LIABILITY FOR INCIDENTALS OR CONSEQUENTIAL DAMAGES.**

Champion does not authorize any other person, including persons who deal in Champion dishwashing machines to change this warranty or create any other obligation in connection with Champion Dishwashing Machines.

## **Operating Instructions**

### **IMPORTANT**

**Please read the steps below before you operate your dishwasher.**

1. Make sure the dishwasher was properly installed and tested prior to operation.
2. Read the operating instructions completely before you operate your dishwasher for the first time.
3. Keep these instructions available for quick reference.
4. Contact your supervisor immediately if you have questions about the dishwasher.
5. Contact your local authorized Champion service agency for technical support.
6. Our National Service Department provides 24 hour support 365 days a year with a Toll-free number in the United States.

**USA National Service**  
**M-F • 8 AM - 5PM EST**  
**Toll-free: 1 (800) 858-44772**

*In the USA, a factory technician will return your call after-hours and during holidays.*

**or**

**Canadian National Service**  
**M-F • 8:30 AM - 4:30PM EST**  
**Toll-free: 1 (800) 263-5798**

## **Operating Instructions**

### *Dishwasher Construction*

1. The Upright Conveyor dishwasher, (also called the flight-type conveyor), is assembled as a single unit from sections or modules.
2. This basic design is then customized to the customer's specifications.
3. The information presented below explains the basic construction of the upright conveyor dishwasher. It does not cover custom-built innovations.
4. Study the diagrams on the next page, then continue reading below.

#### **Dishwasher Sections:**

Five sections make up the basic assembly. The sections are:

Load, Prewash, Wash, Rinse, Final rinse, Unload

#### **Dishwasher Views:**

Plan View

Elevation

Side View

# Operating Instructions

## All Models

The diagrams below are an example, your machine may be different.

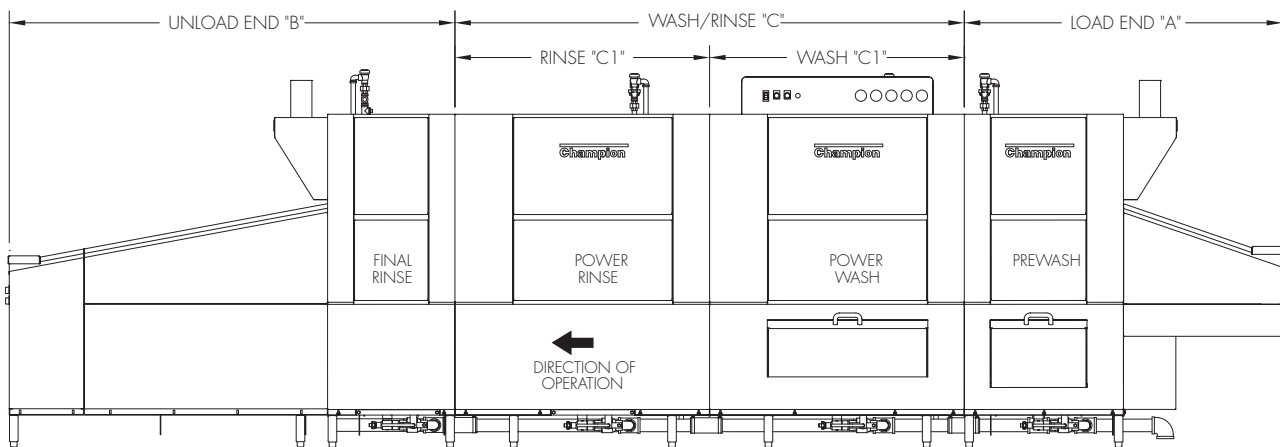
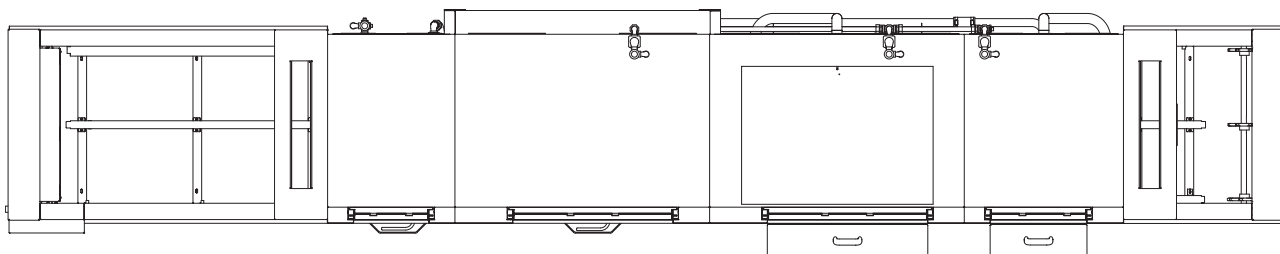

## Operating Instructions

**DO NOT flip the *dishwasher* power switch "ON" until you check the items below.**

1. Check that the following utilities are connected:  
to the dishwasher and ready for use:
  - Electrical service
  - Hot water supply
  - Drain
  - Ventilation
2. Check the chemical connections and chemical containers are installed and ready for operation, (*Consult your chemical supplier for instructions*).
3. Check the interior of the dishwasher for foreign objects and remove.
4. Turn on the water supply to the dishwasher.
5. Turn on the main power switch at the building service disconnect switch.



## Operating Instructions

1. Close all drains.



2. Make sure floats, overflows, drain screens, and pump screens are clean and in place.

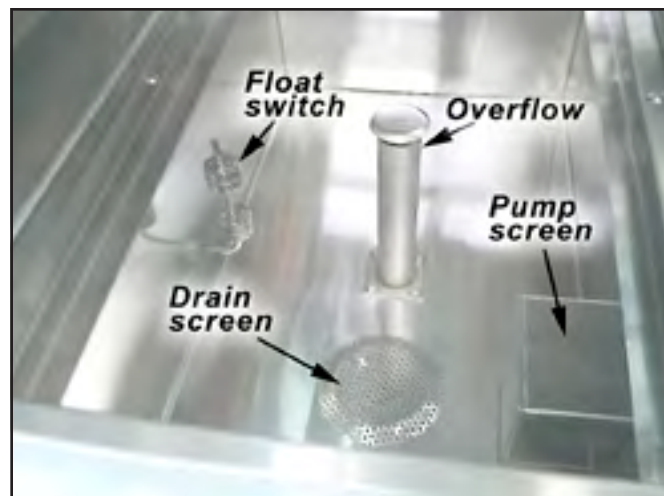

3. Always slide the pump screens up and lift out.

4. Check the bottom to make absolutely sure they are clean.  
Replace in reverse order



## ***Operating Instructions***

1. Place the curtains in the dishwasher making sure the short flaps face the load end of the machine.
2. To install the curtains: Locate the curtain hooks in each section.
3. Place the curtain rod in the rear hook, then lift the opposite end of the curtain rod and place it in the front hook.
4. Place the 19" long curtains at each end of the dishwasher.
5. Place the 14" center curtains in each section.
6. Place the 10" final rinse curtain between the final rinse and auxiliary rinse pipes.

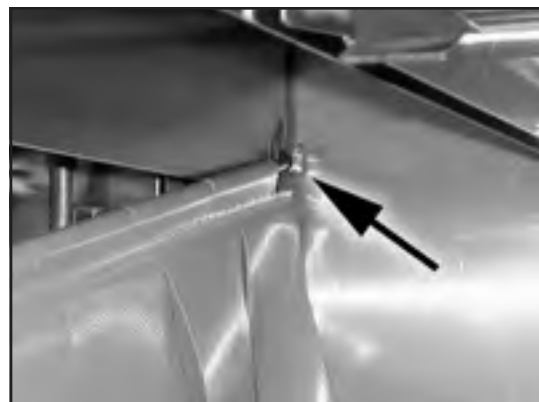

## Operating Instructions

7. Check the upper and lower wash arm manifold o-rings to make sure they are in place and in good condition.



8. Install the upper wash arm assemblies.

9. Install the lower wash arm assemblies.

10. Make sure all wash arm assemblies are locked in place.

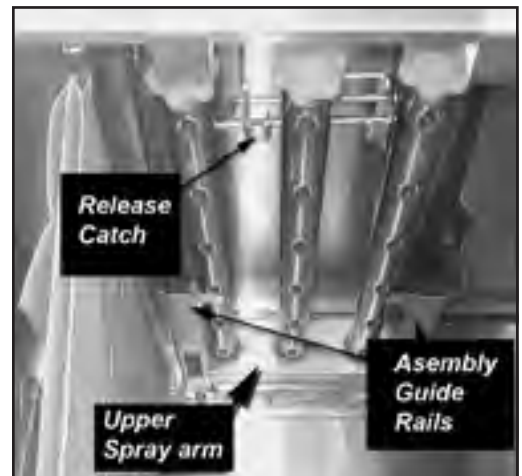

11. The auxiliary rinse section is equipped with an upper and lower rinse arm.



Refer to the illustrations on the next page for a more detailed view of the spray arms.

# Operating Instructions

TO INSTALL UPPER SPRAY ARM:

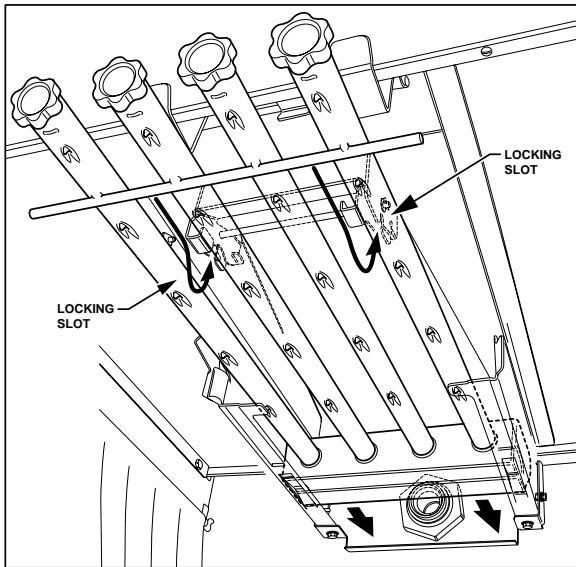

TO REMOVE UPPER SPRAY ARM:

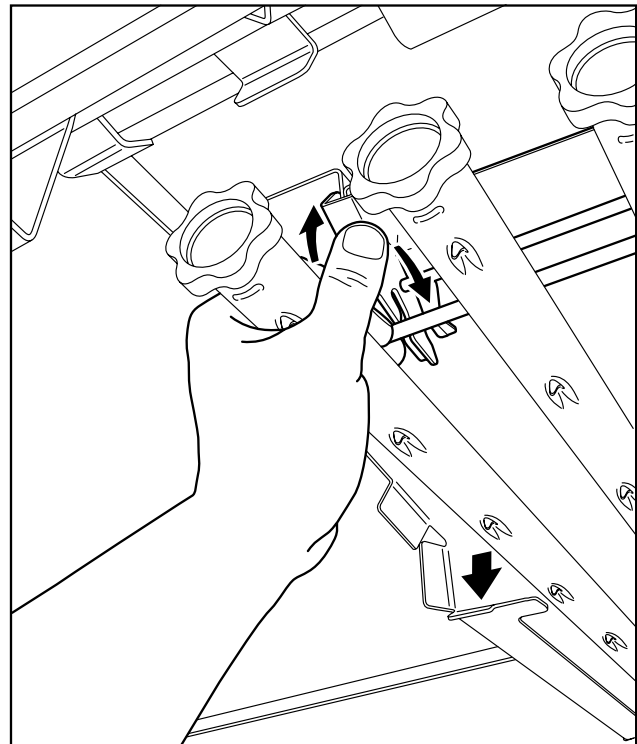
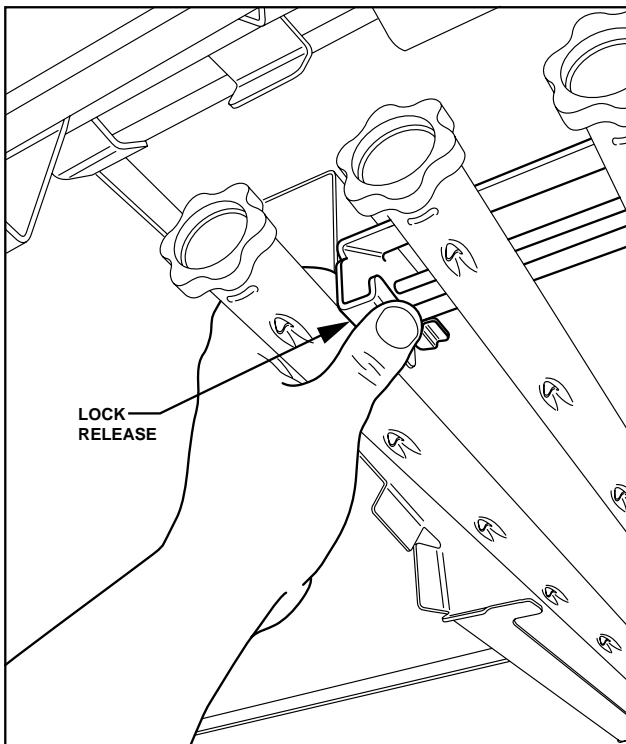
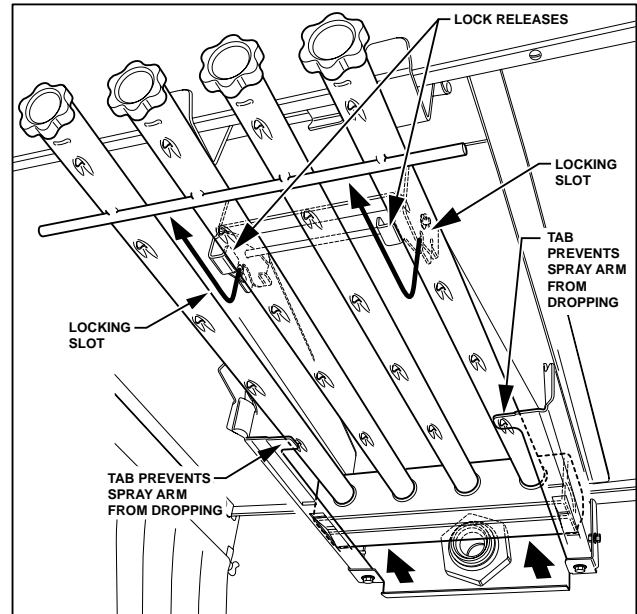

## Operating Instructions

12. There are 2 removable auxiliary rinse spray pipes in the auxiliary rinse section.

13. Make sure the upper and lower auxiliary rinse spray pipe gaskets are in place.



14. Position the spray pipe so the rinse nozzle points toward 10 o'clock.

15. Push the rinse pipe forward.

16. Turn the auxiliary rinse pipe 1/4 turn clockwise to lock it in place.



**Note:**

The final rinse pipes are permanently installed and do not require assembly.

## Operating Instructions

17. Install the scrap screens.



18. Install the scrap baskets if applicable.

19. Make sure the screens are fully seated to the rear of the dishwasher and interlocked into the scrap basket.



## Operating Instructions

20. Close all doors.

21. Lift the door up slightly, then push the door catch back toward the inside of the dishwasher.

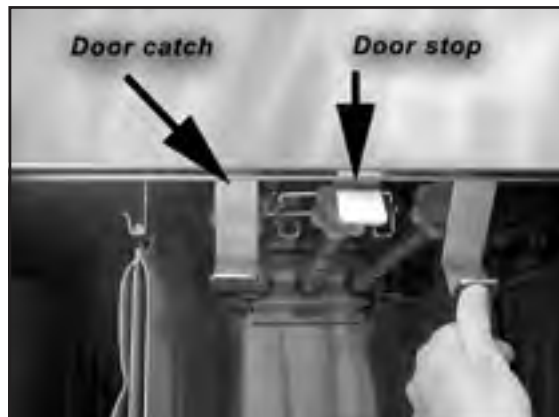

22. Slowly lower the door. The door catch remains disengage

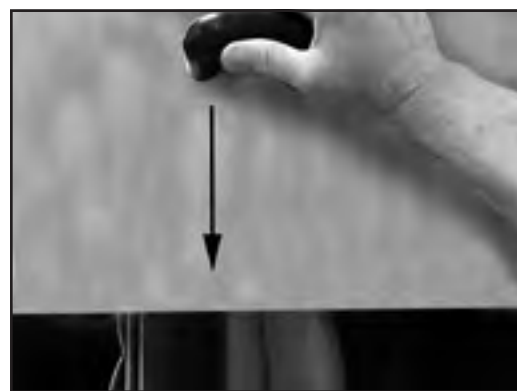

23. There are 2 half-size Econo-rinse doors. The operator lifts the upper door which hooks in place. Next, he lifts the lower door which hooks in front of the upper door. To lower the doors, the operator releases the lower door hook and closes the door then releases the upper door hook to close the upper door.





## Operating Instructions

24. Flip the dishwasher power switch up.
25. The dishwasher automatically fills with water.
26. The tank heat comes on as soon as the tanks are full.
27. Wait for 15-20 minutes to allow the wash and rinse tanks to reach operating temperature.



The wash tanks, auxiliary rinse, and final rinse water temperatures are displayed on digital displays located on the right-side of the control panel. The displays are labeled according to the tank or rinse water section that is being monitored. The illustrations above and below show the arrangement for a Right-to-Left dishwasher. The arrangement would be reversed for a Left-to-Right machine.

The minimum temperatures shown below must be maintained when the dishwasher is washing wares. A longer wait time or corrective measures should be taken immediately to maintain the temperatures.

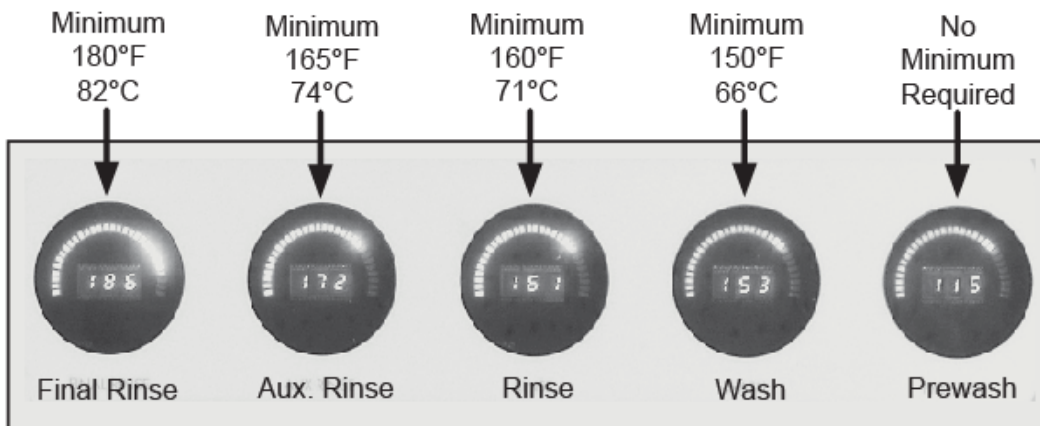

***The prewash tank is not heated so its temperature may be lower than the wash tank. This is okay.***

***The final rinse temperature is checked when the dishwasher conveyor belt and wash pumps are running during normal operation.***



## Operating Instructions

28. Push the **GREEN START BUTTON** to start the conveyor belt.

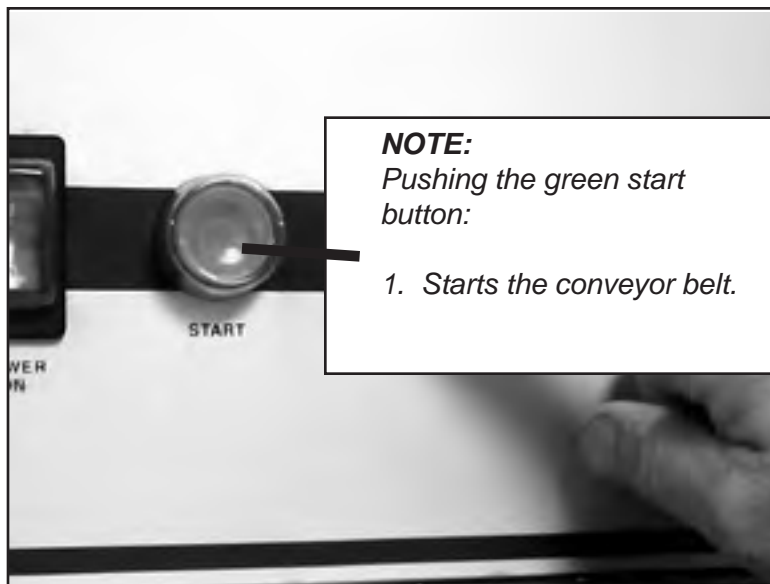

29. Push the **RED STOP BUTTON** to stop the conveyor belt.

The wash pumps stop.  
Tank heaters continue to operate.

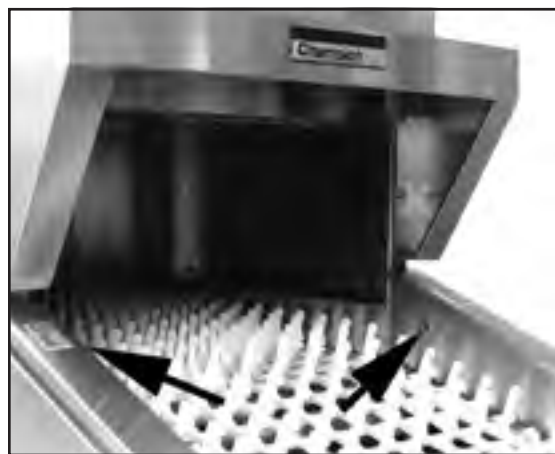

30. Push the **GREEN START BUTTON** to re-start the conveyor belt.



## Operating Instructions

31. Your dishwasher is equipped with start-stop stations. The load station is standard equipment; the unload station is an option.

These stations work exactly as the control cabinet start and stop buttons.

Start-stop stations make it possible for the person loading the wares on the conveyor belt to start and stop the dishwasher as needed.



*Load-end Start-Stop Station*

The person unloading the wares also has the ability to start and stop the dishwasher using the optional unload start-stop station (if it is installed .)

32. Push the GREEN START BUTTON to start the conveyor belt.
33. Push the RED STOP BUTTON to stop the conveyor belt.



*Optional Unload-end Start-Stop Station*

## Operating Instructions

34. An important safety feature designed to stop the conveyor belt during operation is the shut-off shelf.

This device is located at the very end of the unload section.

35. The shut-off shelf moves backward when wares contact it as the belt moves forward.
36. The shut-off shelf stops the conveyor belt. It also turns the blower dryer heat off (if equipped).

The wash pumps continue to operate when the shut-off moves backward to stop the conveyor belt.

37. The unload person may now remove the wares from their end of the dishwasher.
38. The conveyor belt begins moving again when the person moves the shut-off shelf back to its original position.

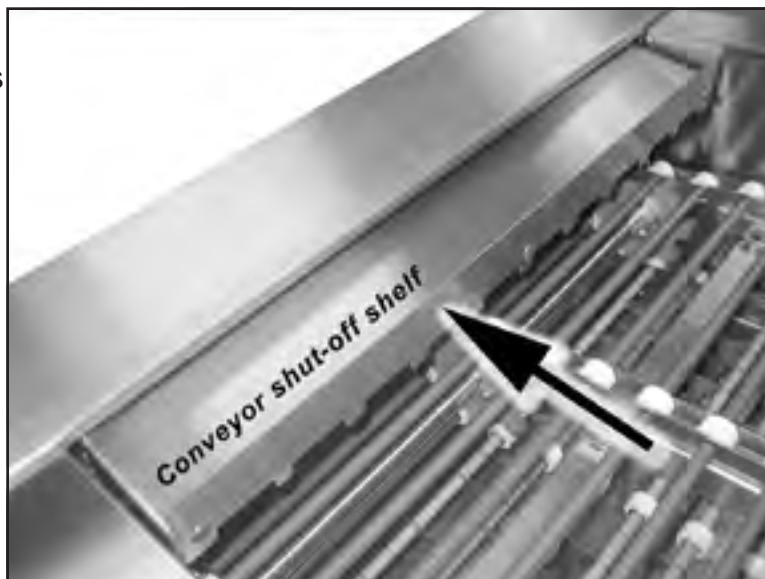

*Shut-off shelf in the RUN position*



*Shut-off shelf in the STOP position*

## ***Operating Instructions***

### ***Daily Maintenance***

1. Keep your dishwasher and the surrounding area clean.

After each meal period or every 2 hours of operation, whichever occurs first and at the end of the day.

Turn POWER OFF

Drain the dishwasher

Remove and clean the curtains

Flush the inside of the machine from top to bottom and all hidden places

Remove and clean scrap screens and baskets flushing with fresh water

Clean drain screens and pump screens

Wipe the exterior of the dishwasher with a soft cloth DO NOT HOSE WITH WATER

Leave doors open so the dishwasher may better dry overnight

2. Immediately report loose, broken or missing parts to your supervisor.
3. Check drains for flow restrictions.
4. Check the dishwasher for leaks.
5. Operate the dishwasher as explained in this manual.

### ***Monthly Maintenance***

1. Inspect pump hoses, door linkage, springs, and exterior of dishwasher for wear.
2. Inspect the wash arm bearings and O-rings.
3. Check the condition of scrap screens and dishracks for damage.
4. Check the toggle switches and indicator lights for damage.
5. Check the wash pump motor for loud bearings and leaking pump seal.

### ***Annual Maintenance***

Call your authorized service agent or local service representative and schedule a complete inspection of your dishwasher by our trained professionals.

***Schedule*** your annual maintenance when you can give the service agent unrestricted access to the dishwasher for at least 2 to 3 hours.

# ***Troubleshooting***

# Troubleshooting

On occasion your machine may not operate as expected. Use the checklist below before you decide that a mechanical or electrical failure has occurred.

**Checklist**

1. Are the main disconnect switches, breakers, or motor overloads turned ON?
2. Are the main water and steam supplies turned ON?
3. Are the drain valves closed?
4. Are the spray pipes and rinse nozzles clean?
5. Are the spray pipes in the proper locations?
6. Are the pump intakes clean?
7. Are the scrap screens clean and in place?
8. Are the thermostats correctly adjusted?
9. Are the high limit temperature thermostats reset?
10. Are the doors fully closed?
11. Are the conveyor shut-off and drive assemblies in operating condition?
12. Are the chemical supplies adequately filled?

If a problem still exists after verifying the checklist, refer to the following

CONDITION	CAUSE	SOLUTION
Conveyor will not run	Door not closed .....	Make sure doors are fully closed
	Door safety switch faulty .....	Contact your service agency
	Start switch faulty .....	Contact your service agency
	Main switch OFF .....	Check disconnect
	Control panel power switch OFF .....	Flip switch ON
	Conveyor shut-off shelf operated.....	Move shelf toward tunnel of machine
	Motor overload protector tripped .....	Reset overload in control cabinet
	Green start button not pressed .....	Press green start button

# Troubleshooting

CONDITION	CAUSE	SOLUTION
A single pump will not run	Motor overload tripped ..... Defective motor	Reset overload in control cabinet Contact your service agency
Low or no water	Main water supply is turned off ..... Drain valves are open..... Doors are not fully closed ..... Faulty fill valve ..... Stuck or defective float switch..... Cross-flow piping misadjusted/ clogged ..... Clogged strainer at supply connection ..... PRV misadjusted or defective.....	Turn on house water supply Close all drain valves Close doors Contact your service agency Free float /Contact service agency Adjust cross-flow setting/Clean piping Clean strainer screen Readjust pressure setting or replace PRV
Continuous water filling	Stuck or defective float switch.....  Fill valve will not close..... Drain valves open.....	Free float/Contact service agency  Clean valve,repair or replace valve Close drain valves
Wash/Rinse tank temperature low	Incoming water temp. at machine low.....  Defective thermometer ..... Defective thermostat ..... Defective electric heater element ..... Low steam pressure or volume ..... Defective steam trap..... Defective solenoid valve .....	Raise incoming temperatureis low 140°F minimum for 40°F rise booster 110°F minimum for 70°F rise booster 180° F minimum without booster Check or replace Readjust setting or replace Check or replace Check steam supply pressure Check or replace Check or replace
Prewash tank temperature is too high (Optional Cold Water thermostat Only)	Incoming cold water temperature too high..... Defective cold water thermostat .....	Lower incoming water temperature to maximum of 65°F Check or replace
Insufficient pumped spray pressure	Clogged pump intake screen ..... Clogged spray pipe..... Scrap screen full ..... Low water level in tank Pump motor rotation incorrect ..... Defective pump seal .....	Clean Clean Must be kept clean and in place Check drain valves Reverse wires L1 and L2 in control cabinet Contact service agency
Insufficient final rinse or no final rinse	Faulty pressure reducing valve (PRV) ..... Improper setting on PRV ..... Clogged rinse nozzle or pipe ..... Improper water line size..... Clogged "Y" strainer.....	Clean or replace Set Flow pressure to 20-22 PSI Clean Installer must change to proper size Clean or replace

## Troubleshooting

CONDITION	CAUSE	SOLUTION
Low final rinse temperature	Low incoming water temperature .....	Raise incoming water temperature 140°F for 40°F rise booster 110°F for 70°F rise booster 180°F without booster
	Defective thermometer .....	Check or replace
	Defective thermostat .....	Recalibrate or replace
	High limit thermostat tripped .....	Reset or replace
Poor washing results	Low steam pressure.....	Check steam supply pressure
	Detergent dispenser not operating .....	Contact the chemical supplier
	Detergent supplied not strong enough .....	Contact the chemical supplier
	Wash water temperature too low	See Condition "Wash/Rinse tank water temperature too low"
	Spray pipes clogged .....	Clean
	Improperly scrapped dishes .....	Check scrapping procedures
	Ware improperly loaded on conveyor .....	Stagger ware on belt
	Maintenance not performed as required .....	See Maintenance Schedule
	Electric elements/steam coils have .... lime build-up .....	Clean and delime Contact the chemical supplier
	Poor drying results	Excessive humidity in warewashing area .....
Improperly stacked dishes after washing .....		Check unloading procedures
Insufficient rinse-aid .....		Contact chemical supplier
Final rinse temperature too low .....		See Condition "Final Rinse temperature too low"



# Installation Instructions

## Plumbing and Electrical Diagram, (P & E)

1. The dishwasher P&E is a documented drawing that contains the critical data for the proper construction and utility connections for the dishwasher.
2. The P&E was reviewed and approved by all authorized persons prior to shipment.
3. The sample diagram below illustrates the format and presentation of the data necessary to connect the dishwasher.

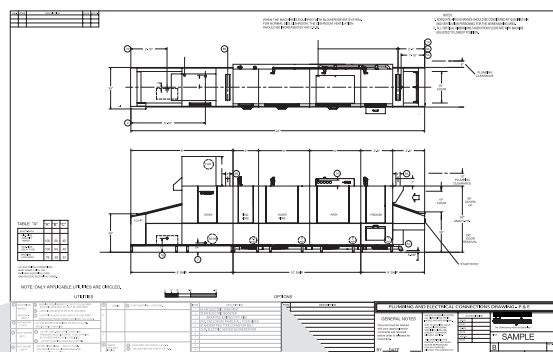

### UTILITIES

ITEM	DESCRIPTION	ITEM	DESCRIPTION
1	55 KW ELECTRIC TANK HEAT	1	55 KW ELECTRIC TANK HEAT
2	32 KW ELECTRIC BOOSTER (MOUNTED & PIPED) 70°F RISE	2	32 KW ELECTRIC BOOSTER (MOUNTED & PIPED) 70°F RISE
3	SST. ENCLOSURE PANELS ALL FOUR SIDES	3	SST. ENCLOSURE PANELS ALL FOUR SIDES
4	STANDARD PEG TYPE CONVEYOR BELT	4	STANDARD PEG TYPE CONVEYOR BELT
5	2 HP. ELECTRIC HEATED BLOWER/DRYER	5	2 HP. ELECTRIC HEATED BLOWER/DRYER
6		6	
7		7	
8		8	
9		9	
10		10	
11		11	

  

①	ELECTRICAL 460/60/3  SEE ELEC. DATA	②	HOT WATER (110°F)	③	COLD WATER (65°F)	④	HOT WATER (180°F)
①	(A) MACHINE REQUIREMENTS 7.7 HP AT 13 LOAD AMPS ELECTRIC TANK HEAT 55 KW AT 66 LOAD AMPS (B) ELECTRIC BOOSTER 32 KW AT 39 LOAD AMPS (C) ELECTRIC BLOWER 25 KW +2HP AT 33 LOAD AMPS (STEPDOWN TRANSFORMER PROVIDES 120V CONT.)	②	3/4" NPT BOOSTER REQUIRES 158 GPH AT 20 PSI. (MAX. 60 PSI. TO MACHINE)	③	A. 1/2" NPT (CWT),(MAX 25PSI) TO MACHINE PRESSURE REDUCING VALVE TO BE SUPPLIED BY OTHERS WHEN CWT IS SPECIFIED B. 1/2" NPT FLUSHING NOZZLES AT 20 PSI.	④	3/4" NPT FINAL RINSE GPH AT 20 PSI. (PRV REQUIRED FOR HIGHER PRESSURE) (MAX. 60 PSI TO MACHINE)
⑤	DRAIN	⑥		⑦		⑧	VENTS (3"X 23") INSIDE
						(A)	LOAD END: 300 CFM AT 1/4" S.P.
						(B)	UNLOAD END: 800 CFM AT 1/4" S.P.

***This Page  
Intentionally  
Left Blank***

# Installation Instructions

1. The illustrations below are an example machine, your machine may be different.

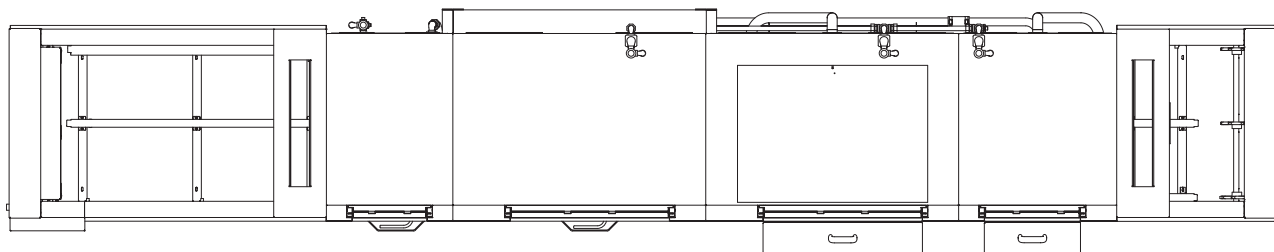

Plan View  
(machine viewed from above)

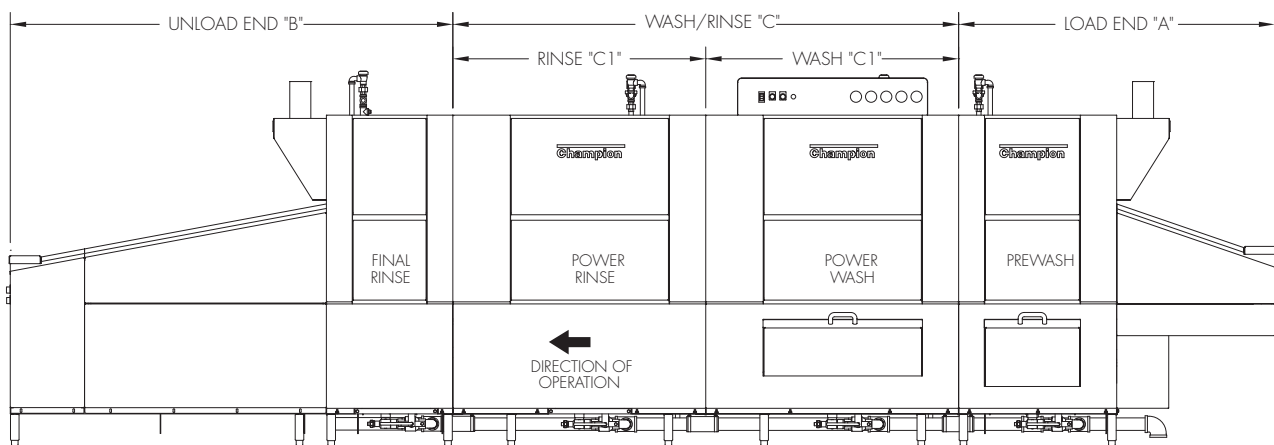

Elevation View  
(machine viewed from front)

## Installation Instructions

### Unpack and Place

#### Unpack and place

1. Upright conveyor dishwashers ship in sections. Each section comes wrapped in a protective covering and secured to a wooden pallet. Labels note the total number of sections shipped, such as 1 of 4.



2. Check the shipment for damage immediately upon receipt. Save all packing materials and pallets, then contact a supervisor, the equipment dealer, and the factory to report the damage.
3. Fasteners, curtains, panels and other pieces are packing in cardboard boxes and secured to the wash/rinse section of the machine. Inventory these parts and report shortages to a supervisor, then store the parts in a secure location.



**CAUTION:**  
Standard 36" doorways often measure less than 35" in width.  
Shipping pallets measure 48" wide.

## Installation Instructions

Unpack and Place

4. Inspect the route that sections must travel if the shipment was not delivered to the dishwashing room. Measure all passageways and doors before moving the dishwasher.

**IMPORTANT**  
Check the utilities early  
Incorrect voltage, hot water supply,  
or steam piping may delay the  
completion of the installation

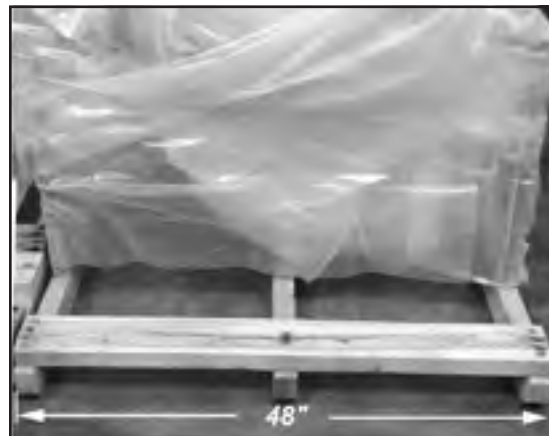

5. Piping on the rear wall of the dishwasher may be removed to allow the dishwasher to pass through narrow openings if necessary.
6. Compare the location of the site utilities with the **Plumbing and Electrical Connection Diagram, (P&E).**

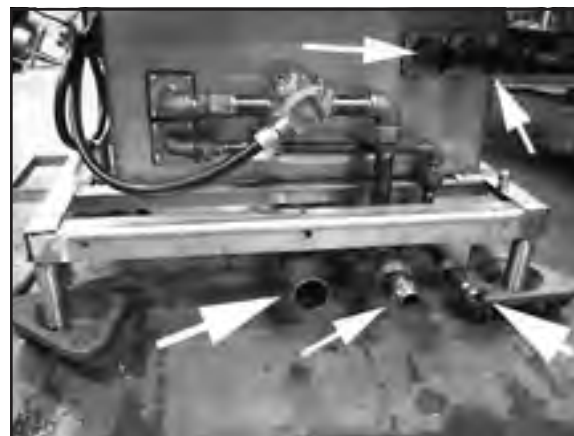

**CAUTION**  
Use extreme care when lifting  
a section off its pallet to prevent  
damage to the dishwasher.



## **Installation Instructions**

### *Order of Assembly*

7. Next, compare the site utilities with the utility connections on the dishwasher.

**The utility locations and ratings of the must match the dishwasher when it is re-assembled in its permanent location.**

**Contact a supervisor immediately if a utility location does not match the dishwasher.**

8. Check floor stability. Flooring must support the weight of the dishwasher without bowing when weight is applied.  
Tiled floors may fracture if loads are dropped on or drug across its surface.
9. Move the palletized sections near their permanent locations. Remove protective coverings, shipping straps, brackets and palletized accessories.
10. Inspect the underside of each section, (below the base) and note the position of piping, valves, and other components that may be in the way
11. Carefully lift each section off the pallet. Screw the adjustable bullet-feet in as far as possible, then lower the section to the finished floor.



# Installation Instructions

## Order of Assembly

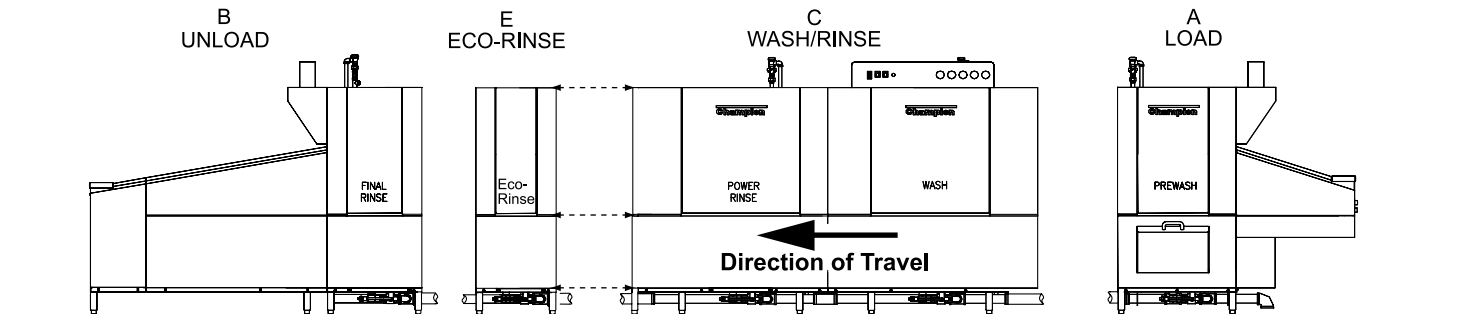

12. The illustration above shows the correct placement of the sections.
13. The recommended spacing between sections is 2 feet. Of course, the size of your dishroom dictates the actual section spacing.
14. Study the illustration above. Note that each section name also contains a designated letter, (A, B, C, E).
15. The illustrated dishwasher is a right-to-left, (R-L) configuration which indicates that soiled wares enter on the right and exit on the left. A left-to-right, (L-R), dishwasher is the reverse of a R-L dishwasher.
16. The "E" or Eco-rinse section is an option and may not be a part of your installation. The dashed lines between the "C" and "E" sections indicate that the "E" section usually ships as part of "C" section.
17. The "C" section ships as a single assy in 4, 6, or 8 ft. lengths.
18. The Order of Assembly should start with the "C" section; however, it is okay to start with the "B" section if the plumber is ready to make the hot water and steam connections.

## **Installation Instructions**

### **Section Assembly**

19. Remove the shipping braces from the sections.
20. Identify the location of piping between the sections.
21. Check the height of each section and determine which section is the highest due to floor variations.
22. Set the "C" section and adjust to its minimum height.
23. Level the "C" section side to side and front to back in several places with a bubble level.
24. The remaining sections are leveled in relation to "C" section. Do not adjust the "C" section too high.
25. Apply a 1/4" bead of FOOD GRADE sealant to the foam gaskets on each section.

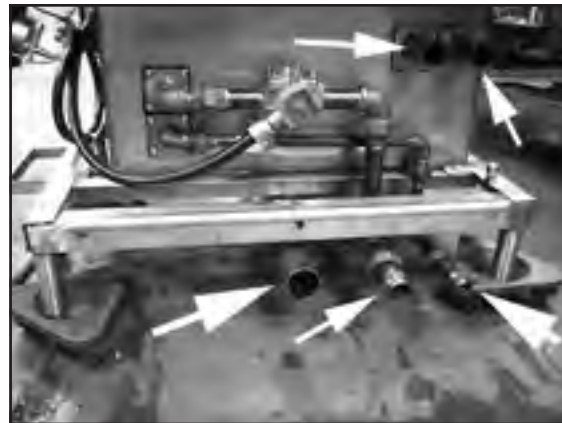

**APPROVED SEALANT WAS SUPPLIED IN THE HARDWARE KIT.**

**DO NOT SUBSTITUTE ANOTHER TYPE OF SEALANT.**

26. Move the next section close to the "C". Adjust the feet of this section to align the 20 bolt holes around the hood.
27. Slide the connecting hoses and clamps on drain pipes and cross-flow pipes. Do not tighten at this time.
28. Level each section side to side and front to back making sure the section connecting bolt holes align.





## Installation Instructions

### Section Assembly

29. Make sure the sections are adjusted to the same height.
30. Check the alignment of the conveyor tracks inside the machine and adjust tracks if necessary. Tracks should align if the sections are level.
31. Bolt all the HOOD sections together with twenty (20), 5/16-18 X 3/4" bolts, lockwashers and nuts included in the hardware kit.
32. Tighten the hood bolts in a cross-pattern to pull the sections together.
33. Silicon sealant should squeeze out of the section joints.
34. Apply a 1/2" bead of Foodgrade sealant in the bottom of the clip.
35. Invert the clip and slide it over the section joint
36. Bolt the clip securely in place.

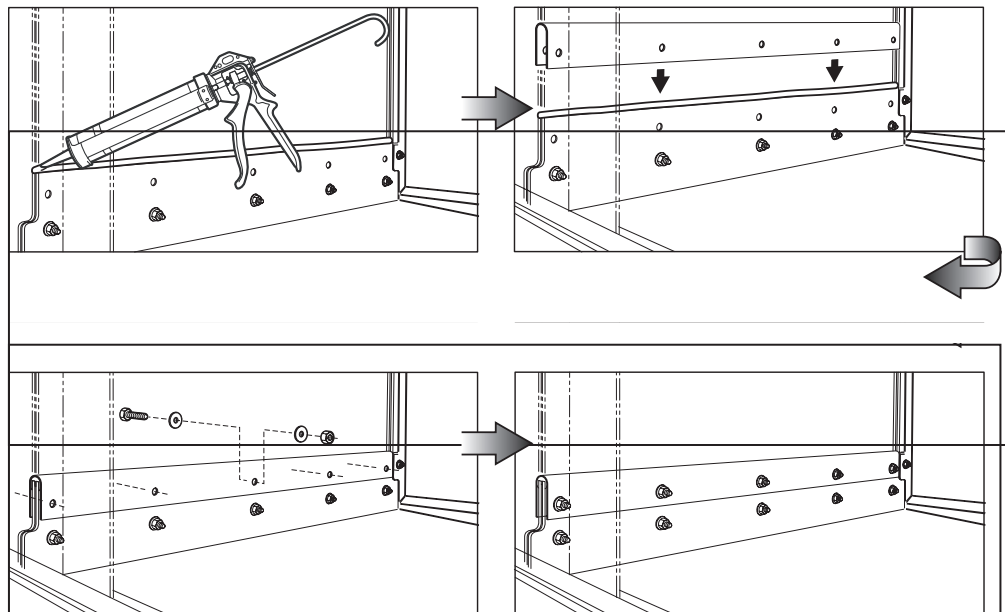

## Installation Instructions

### Conveyor Belt Installation

Beginning with S/N J11062899 and above

1. Remove the key from the conveyor drive sprocket.
2. Start at the unload end of the machine and pull the conveyor belt around the end sprockets until approximately 1.5 feet/76.2 cm of belt rests on the upper track of the dishwasher.
3. Pull a section of belt to the next section along the upper track into the unload end.
4. Join the belt sections together by feeding a conveyor rod through the links, spacers, and rollers. Install a cotter pin on each end of the rod to secure the assembly.
5. Use an assembled rod section on the belt as a guide for the placement of the spacers, etc., continue this procedure until the conveyor belt is assembled in a complete loop.



*Connect the conveyor belt sections with a rod, spacers, and washers included in the hardware kit.*

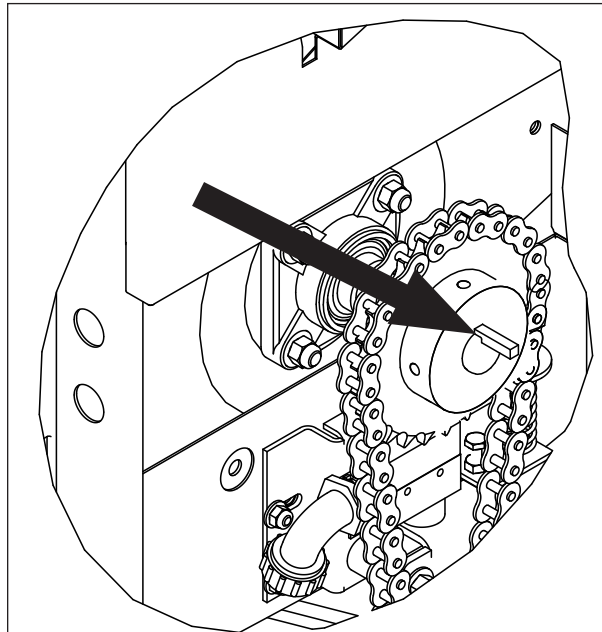

*Remove the key from the conveyor drive sprocket.*

## Conveyor Belt Installation

The take-up assemblies are located on either side of the load end conveyor shaft as shown in **(A)**.

Adjust the conveyor belt tension at the load end. Loosen the adjusting bolt locknuts then turn the adjusting bolts CW to tighten the belt.

Make sure the belt tension is even on both sides.

Check the slack of the lower portion of the belt. The lower belt must not sag.

Continue to adjust belt tension as you manually remove lower belt slack until the lower slack is minimized.

Check the belt tension by lifting the upper conveyor belt at the load end of the dishwasher as shown in **(B)**.

The proper belt tension is achieved when the top of the conveyor belt rods are even with the top of the belt access hole as shown in **(C)**.

**DO NOT OVERTIGHTEN THE BELT.**

Tighten the adjusting bolt locknuts on each take-up assembly to hold the belt adjustment.

Check that the conveyor belt tracks evenly on all of the conveyor drive sprockets during operation and adjust the take-up assemblies as required as shown in **(D)**.

Proper tracking requires that the rollers seat evenly in the conveyor belt drive sprockets. The metal links on the conveyor belt must not rub the sides of the belt sprockets as shown in **(E)**.

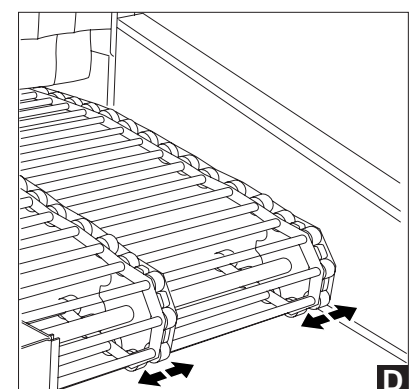
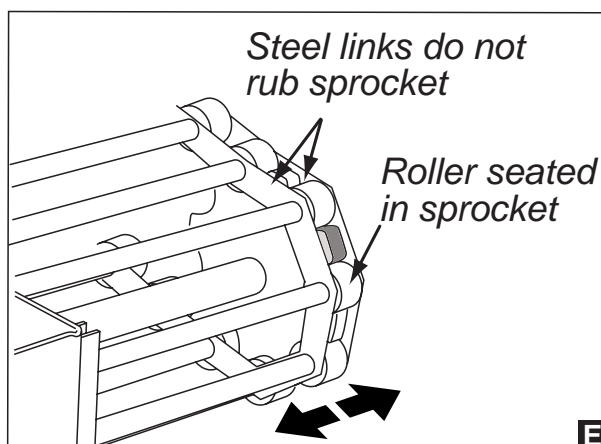
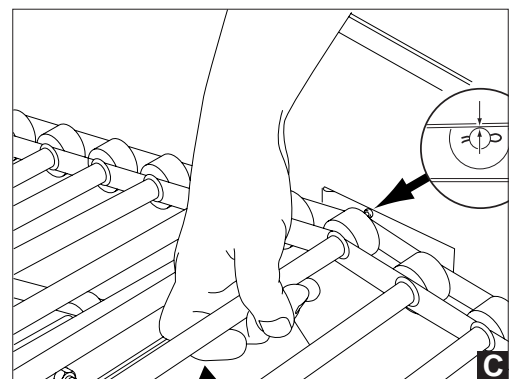
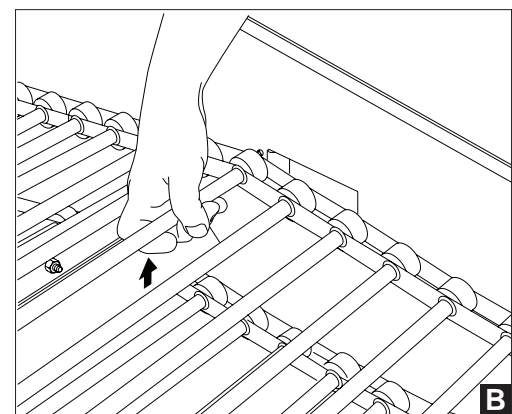
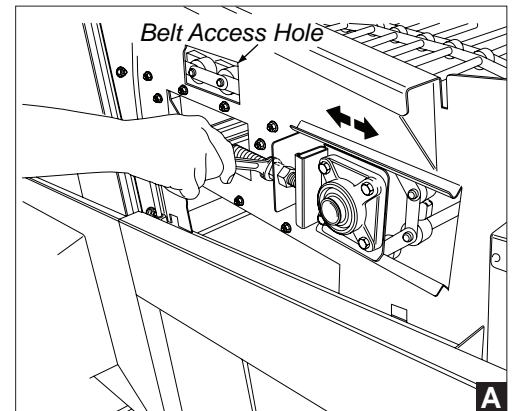

## ***Installation Instructions***

### ***Conveyor Drive***

Beginning with S/N J11062899 and above

There are two conveyor drive designs.

The first is the standard drive comprised of a gear box, drive belt motor and chain connected to the conveyor drive shaft.

The second design is variable speed solid-state electronic speed control, a variable speed motor and a chain connected to the conveyor drive shaft.



*Variable Frequency Drive (VFD) Conveyor Drive Motor*



*Standard Single Speed Conveyor Drive*

The conveyor drive is equipped with anti-jam protection and a reversing switch if an object becomes jammed in the conveyor. This anti-jam mechanism shuts the conveyor drive off to prevent damage to the conveyor belt. The anti-jam switch is adjusted at the factory and should not require adjustment.

#### ***Anti-jam Switch Operation***

The anti-jam switch assembly consists of a base mounting bracket, a limit switch with a mounting bracket, and a spring loaded tensioner arm with a sprocket. A reverse jog switch button is always used in conjunction with the anti-jam switch. The tensioner arm with the sprocket is positioned on the drive side of the drive chain.

When a jam occurs, the drive chain tightens, causing it to straighten changing the position of the sprocket attached to the tensioner arm. When the sprocket position changes, the tensioner arm rotates away from the button on the anti-jam switch causing it to open.

When the switch opens, all power to drive motor is disconnected stopping the forward motion of the conveyor. The drive will not work in the forward direction as long as the anti-jam switch is in the open position.

## Reverse Jog Switch Operation

The Single Speed Reverse Jog operates under the following conditions:

- When the power is on and the anti-jam switch is open due to a conveyor jam.
- When the power is on and the conveyor was stopped via the "STOP". The "START" switch must be pressed to restart the forward motion of the conveyor.
- If the reverse jog switch is pressed while the conveyor is moving forward, the forward motion will stop as long as the switch is pressed. Releasing the switch will restart the belt forward motion.
- If the conveyor is stopped by the shut-off shelf, the "STOP" must be pressed before the reverse switch will work.

The VFD Reverse Jog operates under the following conditions:

- When the VFD is powered on regardless if the machine power is off.
- If the button is pressed when the conveyor is moving forward, the conveyor will run in reverse as long as the button is pressed; releasing the button returns the forward motion of the belt.
- When the anti-jam switch is open and the reverse button is pressed, the conveyor will run in reverse as long as the button is pressed. Releasing the button stops the conveyor. The START button must be pressed to restart the conveyor.
- The reverse button will work if the belt was stopped by the shut-off shelf.



Reverse Jog Switch

### Anti-Jam Switch Adjustments

The anti-jam switch has three adjustments. Refer to the letters in the photo at right:

- The base mounting bracket has horizontal slots for positioning the tensioner arm sprocket against the drive chain. This is a factory setting and should not require changing.
- The limit switch bracket has vertical slots to adjust the switch up and down. Raising the switch reduces the switch reaction time, lowering it increases the reaction time.
- The tensioner arm spring sets the amount of force required to operate the jam switch. The tighter the spring the more load it takes to operate the switch and stop the conveyor.

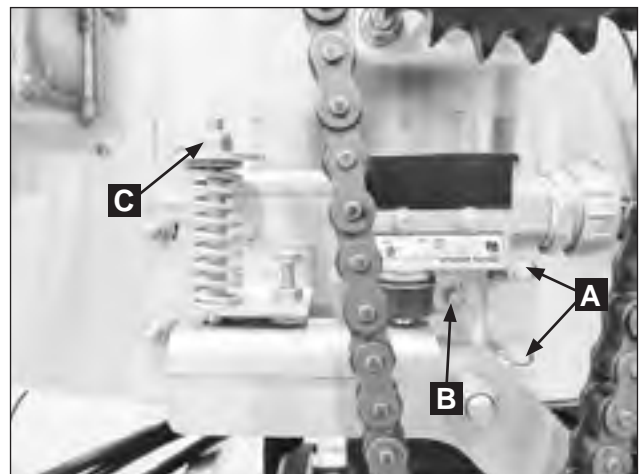

Anti-jam Switch



## **Installation Instructions**

### *Section Assembly*

21. The Installation Supervisor must inspect the position, level and proper connection of the piping connections.

22. Steam supply and condensate unions must be tight.



23. Drain piping must be checked.

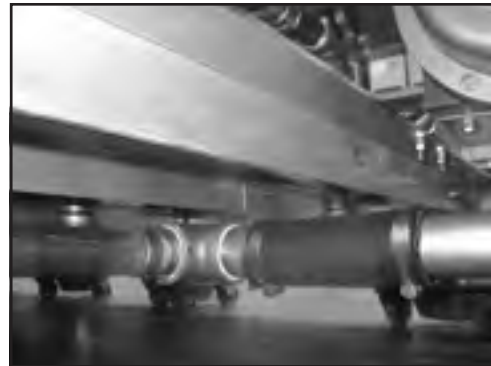

24. Cross-flow hoses must be inspected and clamps tightened.



25. Flushing nozzle piping on the load end must be inspected.

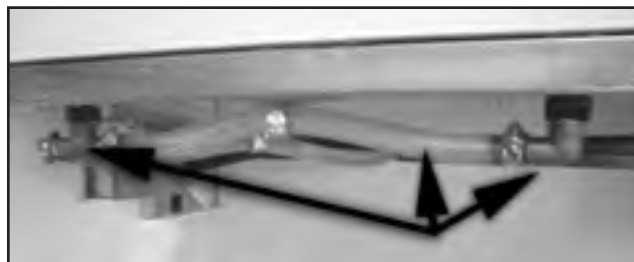

# Installation Instructions

## Section Assembly

26. Check and tighten the fill piping compression fittings.
27. Make sure solenoid coils are positioned correctly on the valve assemblies.
28. Vent stacks must be placed on the hood with vent handles facing the front of the dishwasher.
29. Panels must be rechecked for missing parts, and the location numbers checked with the numbers located on the dishwasher.
30. Tanks must be checked for debris and metal tailings must be vacuumed out of the machine.
31. Curtains must be installed. Install the curtains. Long curtains hang in hooks on each end of the machine. Short curtains hang in hooks on the inside of the machine.
32. Scrap screens, scrap baskets must be checked and installed in the dishwasher.



## **Installation Instructions**

### **Optional Blower Dryer Assembly**

1. The blower dryer comes in electric or steam.
2. It ships on a separate pallet.  
The vent cowl and mounting hardware are included in the accessories box and hardware kit.
3. Lift the blower dryer off the pallet with a forklift and place on the end of the unload section.  
  
If a forklift is not available, then four (4) men are needed to lift and install the unit manually.
4. Bolt the blower dryer in place using the 5/16-18 X 3/4" bolts, flat washers, and lock washers from the hardware kit.
5. Fasten the vent cowl on the discharge end of the blower dryer using the 1/4-20 plain nuts, flat washers, and lock washers from the hardware kit.
6. Connect the flex-tite conduit to the junction box located at the rear of the dishwasher.
7. Match wire numbers in the junction box and connect with wire nuts.
8. Close the junction box.
9. Install the cowl to the end of the blower dryer.

**REFER TO THE BLOWER-  
DRYER SERVICE MANUAL  
P/N 114316**

**SHIPPED WITH THE  
BLOWER-DRYER  
ASSEMBLY**

**FOR COMPLETE  
INSTALLATION  
INSTRUCTIONS.**





# Installation Instructions

## Connect the dishwasher internal electric wiring

1. Wires, flex-tite, and some components were disconnected and pulled back to each section, then junction boxes were closed.
2. Open all junction boxes, identify the flex-tite conduit connections, (A) roll-out wire bundles, (B), and match wire numbers attached on wires, (C).
3. Connect the flex-tite conduit to their associated junction boxes.
4. Connect matching wires using the supplied wire nut connectors, (D) included in the hardware kit.
5. Connect #2 and any white wires together. All of these wires are neutral returns.
6. Close all junction boxes.

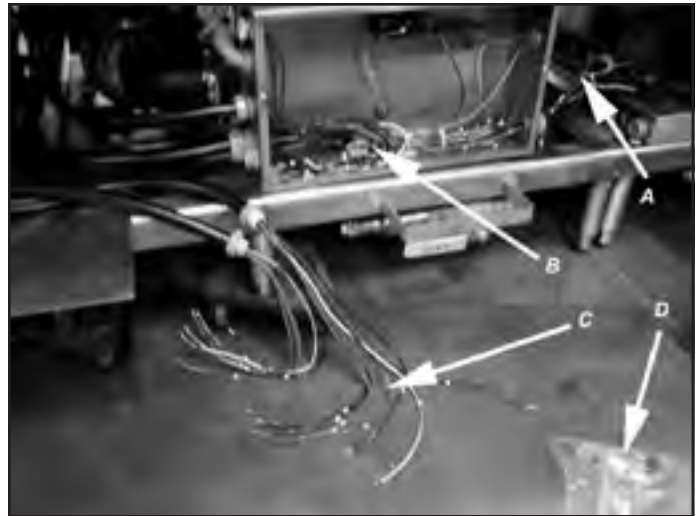

## **Installation Instructions**

### *Section Assembly - Seal Joint Sections*

1. Section joints must be sealed with foodgrade silicon sealant.
2. Mask the joint edges with a quick-release masking tape.
3. Apply a 1/8" bead of Foodgrade silicon sealant. Apply moderate pressure on the gun to ensure the sealant fills the joint.
4. Wait 45-seconds for the sealant to firm slightly. Then wipe the joint with a damp cloth.

Do not wait longer than 1 minute for the sealant to firm. The sealant will not wipe correctly.

5. If the sealant dries longer than 1 minute, DO NOT try to wipe the joint. Allow the sealant 30 minutes to dry, then cut the sealant out of the joint and begin again.
6. Wait 10-seconds after wiping the joint, then remove the masking tape.
7. Continue sealing the joints.  
  
DO NOT SEAL more than one joint at a time. The sealant will dry faster than you can work the joint.

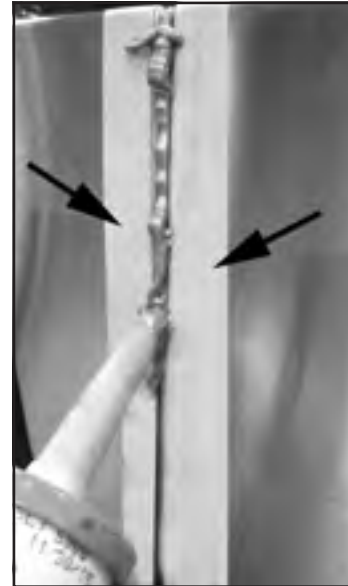

## **Installation Instructions**

### *Section Assembly - Seal Joint Sections*

8. Study the photos on the right. The top photo shows a correctly sealed joint.

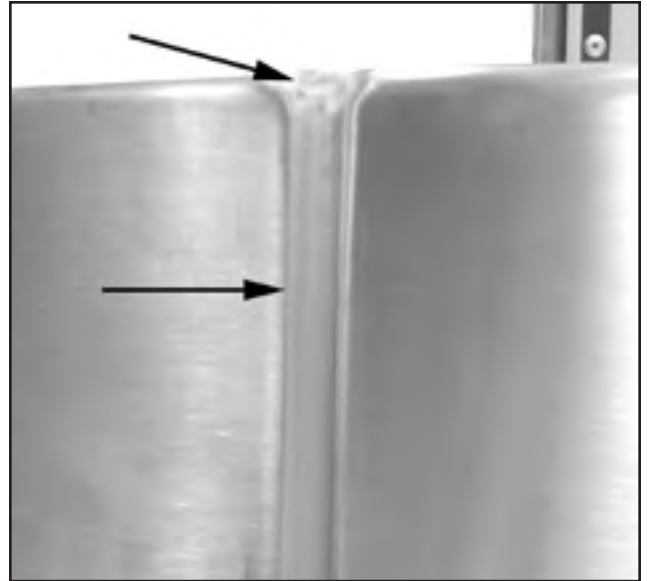

9. The stainless steel must be wiped with Isopropyl alcohol to remove dust, oil film, and other contaminants.

10. Note that the joint is filled presenting an even transition between sections.

11. The sealant is applied past the top radius of the joint presenting a uniform fill.

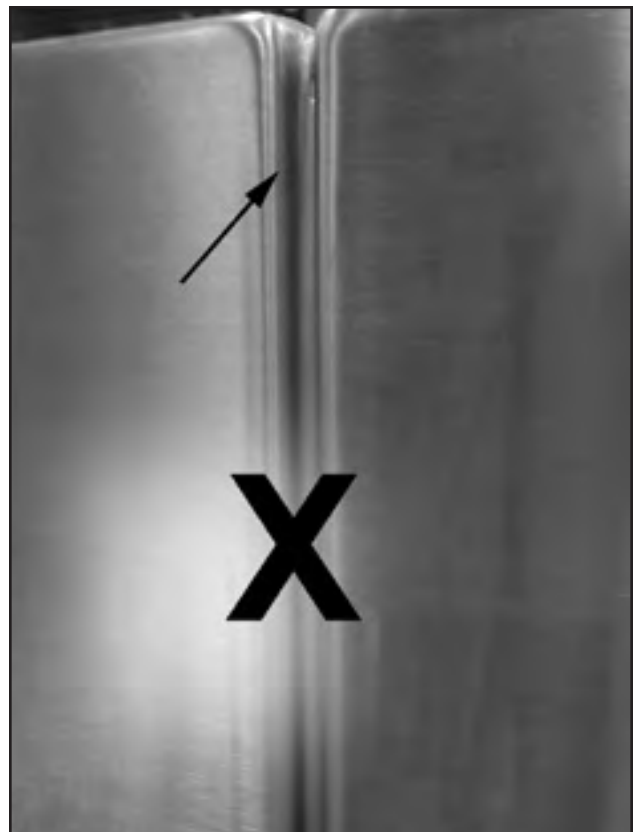

- 12.. Study the lower sealed joint. This joint did not have enough sealant applied and therefore presents a crevasse where soils may be trapped.

13. Practice this procedure on a hidden joint if you experience problems with the procedure.

## Installation Instructions

### Supply Connections - Main Incoming Power

The Main incoming power to the dishwasher is made at the top of machine in the control cabinet.

The electrician must connect the power supply in accordance with the data stamped on the Machine Electrical Connection Plate.

This data is the ultimate authority and is not superseded by any other data supplied in print, or conveyed verbally.

**WARNING:**

Electrical and grounding connections must comply with the National Electrical Code and/or Local Electrical Codes.

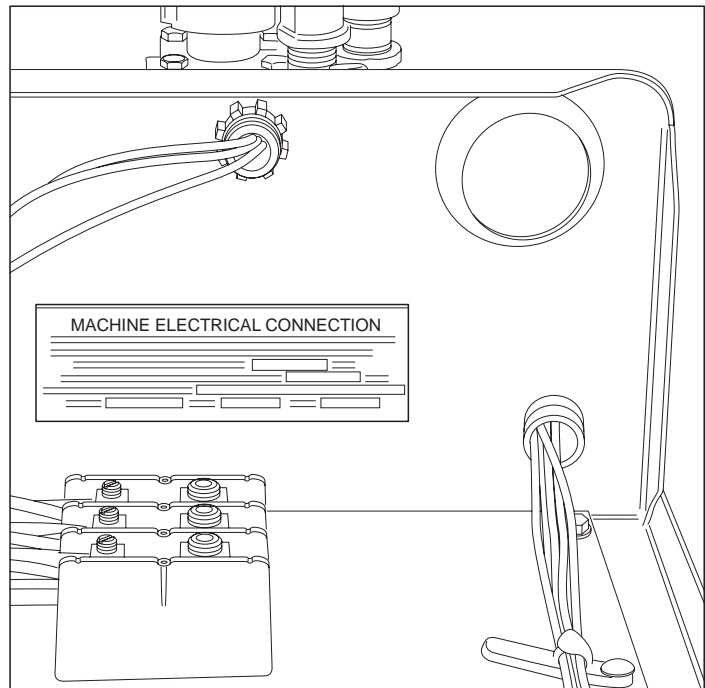

**WARNING:**

When working on the dishwasher, disconnect the electric service and place a tag at the disconnect switch to indicate work is being done on that circuit.

**Note:**

A qualified electrician must compare the electrical power supply with the machine electrical specifications stamped on the MACHINE ELECTRICAL CONNECTION PLATE located inside the control cabinet before connecting to the incoming service at a fused disconnect switch.

## **Installation Instructions**

### *Supply Connections - Water and Steam*

**IMPORTANT**

*Main utility supply connections must be performed by licenced tradesmen who abide by local building, health and sanitation codes or national codes in the absence of local codes.*

**THE MAIN INCOMING HOT WATER AND STEAM SUPPLY CONNECTIONS ARE MADE IN THE LOWER PART OF "D" SECTION**



**Hot water connection**

**ATTENTION INSTALLERS AND SUPERVISORS**

**REFER TO THE PLUMBING & ELECTRICAL CONNECTION DIAGRAM FOR THE LOCATION AND SIZE OF ALL UTILITIES.**



**Steam and condensate connection**

**BUILDING VENTILATION CONNECTIONS ARE MADE AT THE TOP OF THE "A" AND "D" SECTIONS.**

**BUILDING VENTS MUST ALIGN WITH THE DISHWASHER CENTER-LINE AND MATCH THE SIZE OF THE DISHWASHER VENT DUCTS.**

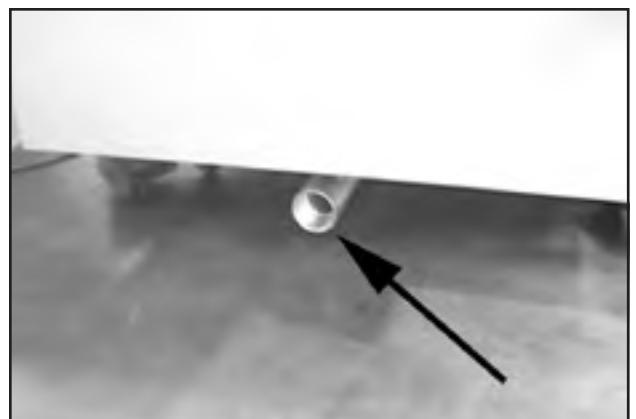

**Drain Connection**

# Installation Instructions

## Supply Connections - Chemical Dispensers

Chemical dispensing systems are supplied by others.

A connection point for detergent, and rinse-aid signals is provided in the in the top-mounted control cabinet.

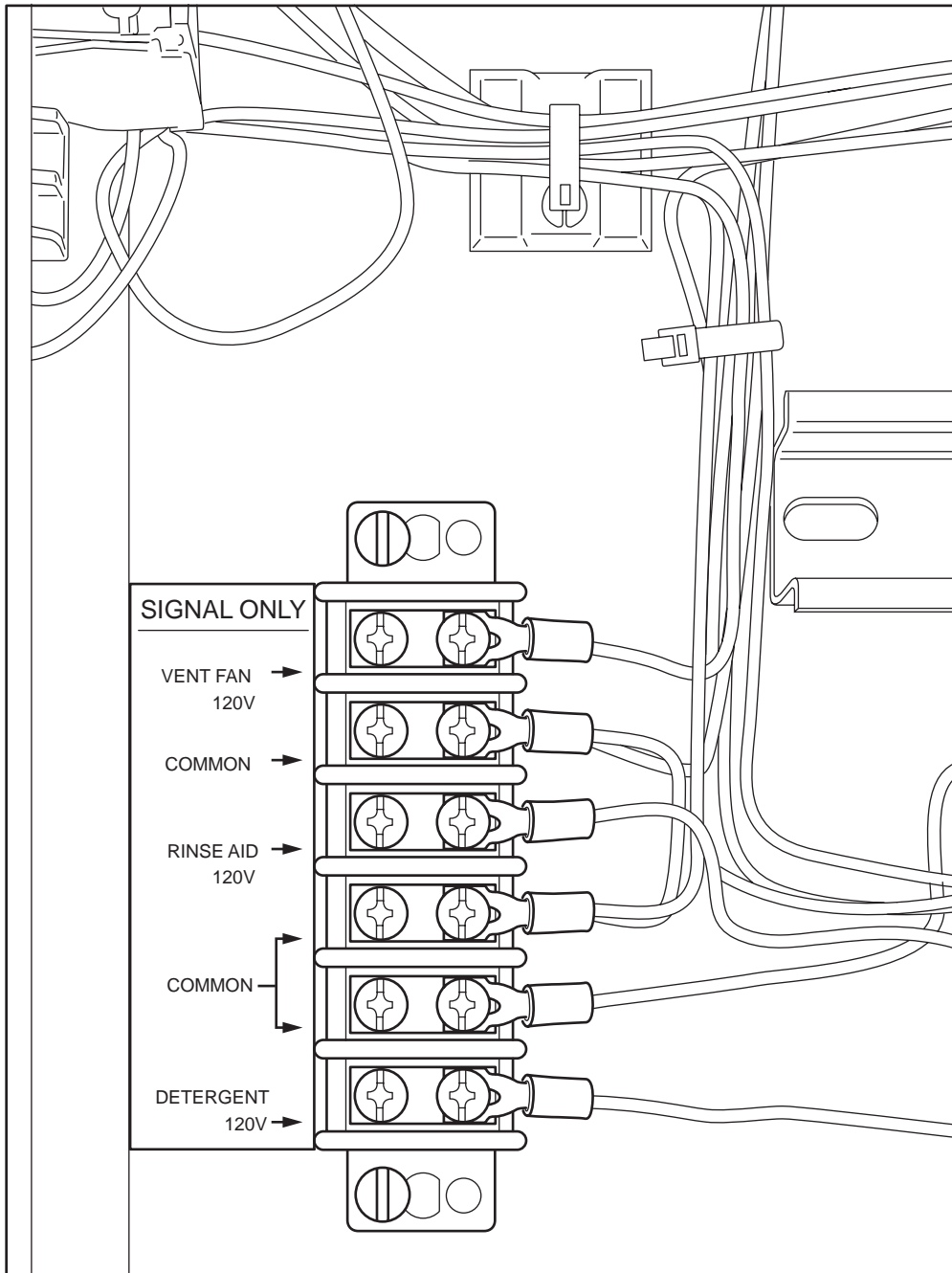

# **Installation Instructions**

## **Initial Start-up**

Perform the following checks and adjustments before placing the machine into service.

- Check the interior of the machine and remove any foreign material.
- Check the exterior of the machine — make sure that the conveyor belt is free of tape and foreign material.

### **Baffles –**

Tank baffles redirect the flow of water from the spray arm systems back into the tanks. This prevents water loss and keeps the wash, rinse, and final rinse water in the proper tank. Check the baffles — make sure that they are installed and positioned correctly.

Close the tank drain valves along the lower front of the machine.

Open the water supply valves. Check for leaks and take corrective action as required.

Open the steam supply valves (if applicable). Check for leaks and take corrective action if required.

Turn the main power on at the breaker panel or fused disconnect switch.

Machine main power

Electric booster main power (if applicable)

Flip the Power Switch on the front of the Control Cabinet to the "ON" position.

The Red power on light will illuminate.

The machine will begin to fill with water.

Allow the machine to completely fill with water.

The water will shut off automatically.

Check for leaks and take corrective action if required.

Monitor the tank thermometers for the proper temperature reading.

Allow sufficient time for the tank heat to reach operating temperature.

Move the conveyor shut-off shelf located at the end of the unload section toward the machine. This resets the automatic conveyor stop system.

When an object on the conveyor contacts the shut-off shelf, the conveyor stops.

Press the GREEN start button on the front of the control cabinet.

## ***Installation Instructions***

### ***Initial Start-up***

Check the direction of rotation of the conveyor belt by observing the direction arrow decal on the large conveyor drive sprocket. The sprocket is located on the side of the unload section.

If rotation direction is incorrect, reverse wires L1 and L2 on the disconnect switch side of the main electrical connection terminal block located inside the control cabinet.

Each temperature gauge is marked with its proper operating range.

Check the Energy Sentinel (idle pump shut-off) by placing a tray or dish on the moving conveyor belt.

The pumps will start as the object enters the tunnel of the machine.

The optional econo-rinse pump starts with the final rinse.

Check pump motor rotation, CW when viewed from the rear of motor.



Check the final rinse temperature as the object enters the final rinse area.

The Final rinse temperature must be 180-195°F.

Adjust the temperature of the incoming water supply if necessary.

Adjust the booster thermostat setting if necessary.

Check the Final rinse water pressure as the object enters the final rinse area.

The final rinse pressure must be 20-22 PSI.

Adjust the Pressure Reducing Valve setting if necessary.

Check that the pumps and final rinse shut-off before the object reaches the conveyor shut-off shelf.

Check that the conveyor belt stops when the object pushes the conveyor shut-off shelf.

Move the shut-off shelf toward the tunnel of the machine. The conveyor belt will start moving again.

Push the RED stop button. The conveyor belt will stop moving.

Flip the power switch on the control cabinet to OFF. The red power light will go out.

Open all the drain valves and check that the house drains can handle the flow.

Remove any protective film from the stainless steel and install the side panels and chain guard.

Check the curtains for correct placement in the machine.

Be sure the short flaps of the Long Curtains face the load end of the machine.

Check the spray pipes.

Be sure the spray pipe gasket is installed on the end of spray pipe before installing.

Spray pipes are installed by inserting the pipe into the coupler and turning 1/4 turn clockwise.

Check the scrap screens.

Install any scrap basket covers.

Check that the conveyor shut-off shelf is pushed toward the machine tunnel.

Close the drain valves, located under the base of each tank.

When the drain handle is horizontal, the valve is open.

When the valve handle is vertical, the valve is closed

Check the detergent and rinse aid supplies (supplied by others).

***This Page  
Intentionally  
Left Blank***

# Service Replacement Parts

<u>Illustration</u>	<u>Page</u>
Pump/Motor Assembly.....	48
3HP, C3/C4 Pump Installation.....	50
1HP, B-30 Prewash Right-Left Pump Installation.....	52
1HP, B-30 Prewash Left-Right Pump Installation.....	54
3HP, B-30 Prewash Left-Right Pump Installation.....	56
3HP, B-30 Prewash Right-Left Pump Installation.....	58
Auxiliary Rinse Right-Left Pump Installation.....	60
C8 Wash/Rinse Wash System Installation.....	62
1HP 30" Prewash Right-Left Wash System Installation.....	64
1HP 30" Prewash Left-Right Wash System Installation.....	66
C4 Single Tank Wash System Installation.....	68
C6 Wash/Rinse Wash System Installation.....	70
C4 Wash without Scrap Basket Electric Tank Heat Installation.....	72
C4 Rinse without Scrap Basket Electric Tank Heat Installation.....	74
C4 Wash with Scrap Basket Electric Tank Heat Installation.....	76
C4 Rinse with Scrap Basket Electric Tank Heat Installation.....	78
Auxiliary Rinse Tank Heat Installation.....	80
Electric Booster Element Configurations.....	82-87
Electric Booster Installation.....	88
Float Switches.....	90
Final Rinse Installation EUCC8/EUCCW8.....	92
Final Rinse Installation C4/C6 EUCC/EUCCW.....	94
Auxiliary Rinse Installation EUCC/EUCCW.....	96
Cold Water Fill Piping Sub-assembly.....	100
Electric Booster Fill Piping (Prior to S/N J10012728).....	102
Electric Booster Fill Piping (Beginning with S/N J10012728 and above).....	104
Fill Piping - No Booster (Prior to S/N J10012728).....	106
Fill Piping - No Booster (Beginning with S/N J10012728 and above).....	108
#120-1 Steam Booster Installation RL.....	110
#120-1 Steam Booster Assembly RL 40-70°F.....	112
#120-1 Steam Booster Installation LR.....	116
#120-1 Steam Booster Assembly LR 40-70°F.....	118
Steam Coil Heat Installation C4 Wash, Rinse 15-30 PSI.....	122
Steam Coil Heat Installation C3 Wash, Rinse 15-30 PSI.....	124
Steam Coil Heat Installation Auxiliary, 15-30 PSI.....	128
Steam Injector Heat Installation C4/C8, 15-30 PSI.....	132
Steam Injector Heat Installation Auxiliary Rinse RL.....	136
Drain Installation B-30 Prewash RL.....	138
Drain Installation B-30 Prewash LR.....	140
Drain Installation C4 Wash, Rinse.....	142
Drain Installation Auxiliary LR.....	144
Drain Installation D5 Unload.....	146
Drain Installation B4 Prewash RL.....	148
Drain Installation B4 Prewash LR.....	150
Drain Installation C3 Wash, Rinse.....	152
Electric Eyes, Start-Stop Station, Flushing Nozzles.....	154
Idle Shaft Assembly.....	156
Drive Assembly, Prior to S/N J11062899.....	158
EUCCW Peg Belt and Peg Belt with Upper Rod Conveyor Belts.....	160
EUCCW Flat and Insulated Conveyor Belts.....	162
EUCCW Stainless Steel Conveyor Belt.....	164
EUCC Peg Belt and Peg Belt with Upper Rod Conveyor Belts.....	166
EUCC Flat and Insulated Tray Belts.....	168
EUCC Stainless Steel Conveyor Belt.....	170
Vent Cowl Installation.....	172
Curtain Locations.....	174-185
Tank Baffles EUCC/EUCCW.....	186
Control Cabinet (From S/N J2098 up to J08102541).....	188
Control Cabinet (From S/N J08012541 up to J10012728).....	192
Control Cabinet (Beginning with S/N J10012728 and above).....	196
Standard 30" Door Assembly.....	200
Split Door Assembly.....	202
Swing-out Door Assembly - B-30 R-L/E2 L-R.....	204
Swing-out Door Assembly - E2 R-L/ B-30 L-R.....	206
Swing-out Door Assembly - C4.....	208
Scrap Screens.....	210
Conveyor Shut-off Shelf.....	211
Drive Assembly, Beginning with S/N J11062899 and above.....	212
L-R Anti-jam and Tensioner Assembly.....	213
R-L Anti-jam and Tensioner Assembly.....	214
Reverse Jog Switch Assembly.....	215
Hot Water Coil for C3, EUCCW.....	216

Pump/Motor Assembly

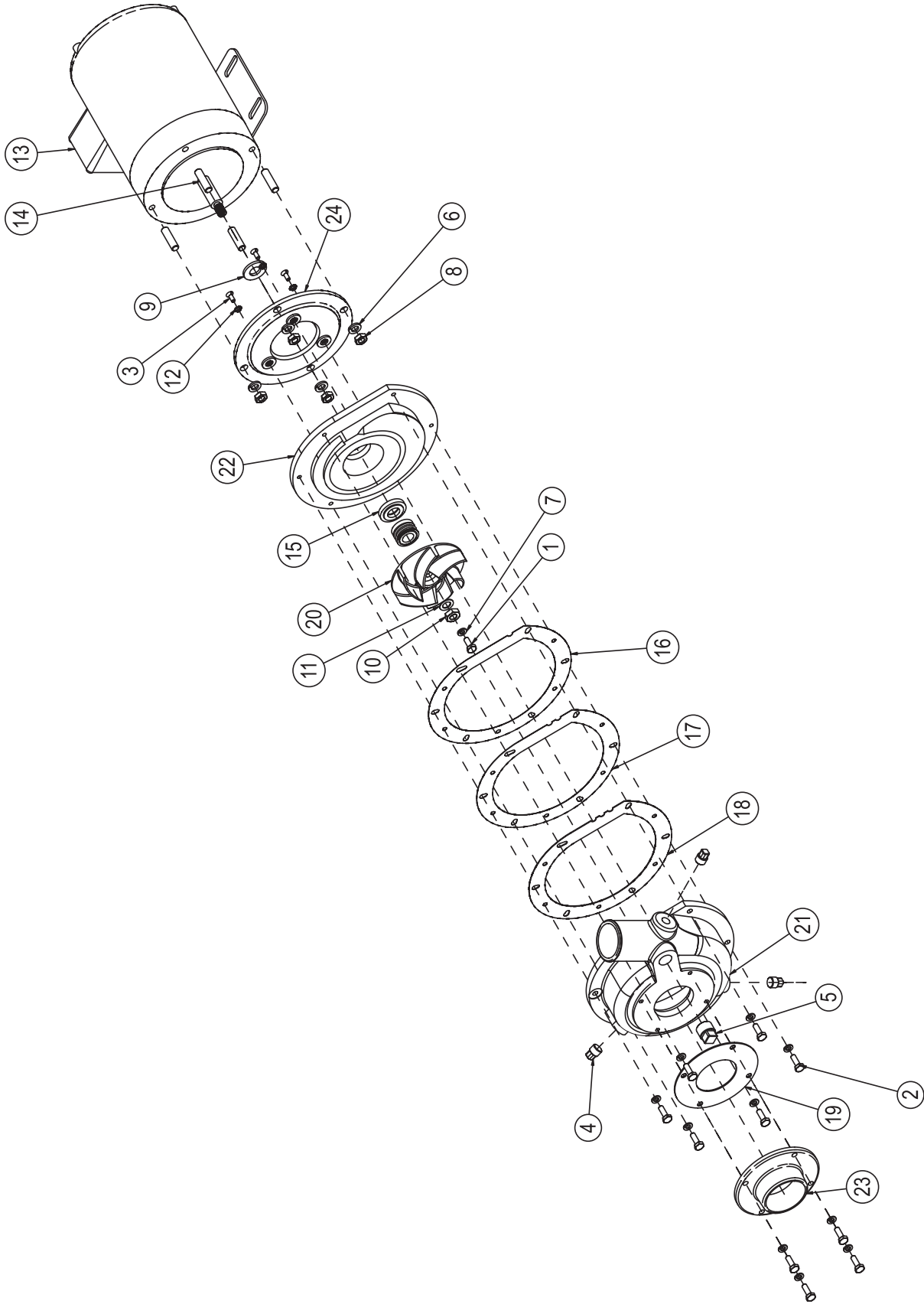

Item No.	Part No.	Description	Qty.
1	100735	HEX HEAD,1/4-20 X 5/8 SST	1
2	100736	HEX HEAD,1/4-20 X 3/4 SST	10
3	100754	SCREW,FLAT HEAD,10-32 X 1/2 SST	3
4	102500	PLUG,1/4"NPT SQ.HEAD,BRASS	3
5	102504	PLUG,1/2"NPT SQ.HEAD,BRASS	1
6	106407	WASHER,LOCK,3/8 SPLIT,SST	4
7	106482	WASHER,LOCK,1/4 SPLIT,SST	11
8	107690	HEX PLAIN JAM NUT,3/8-16 SST	4
9	109654	SLINGER, JET PUMP	1
10	110247	HEX PLAIN JAM NUT,7/16-14 SST	1
11	110248	WASHER,FLAT,.440x.750x.043 SST	1
12	110270	WASHER,LOCK,CSK EXTERNAL TOOTH,#10	3
13	110424	MOTOR,3HP 3PH, MV JET PUMP	1
14	110734	STUD,3/8-16 X 1 3/8 LG.SST,PUMP	4
15	111111	SEAL ASSY,CI PUMP	1
16	111941	GASKET,PUMP VOLUTE,.0085 THICK	1
17	111942	GASKET,PUMP VOLUTE,.015 THICK	1
18	111943	GASKET,PUMP VOLUTE,.032 THICK	1
19	112338	GASKET,PUMP SUCTION FLANGE	1
20	113120	IMPELLER,3HP SST,MACHINED B4 /C3 / C4 EUCCW	1
---	---	IMPELLER,3HP SST,MACHINED B4 / C4 EUCC	1
---	113119	IMPELLER,3HP SST,MACHINED C3 EUCC	1
21	113634	VOLUTE,JET PUMP,SST	1
22	113635	FLANGE,JET PUMP,SST	1
23	113636	SUCTION FLANGE	1
24	204460	BACKING PLATE,NG JET PUMP	1
	113263	MOTOR, 3HP, 575V/60/3	

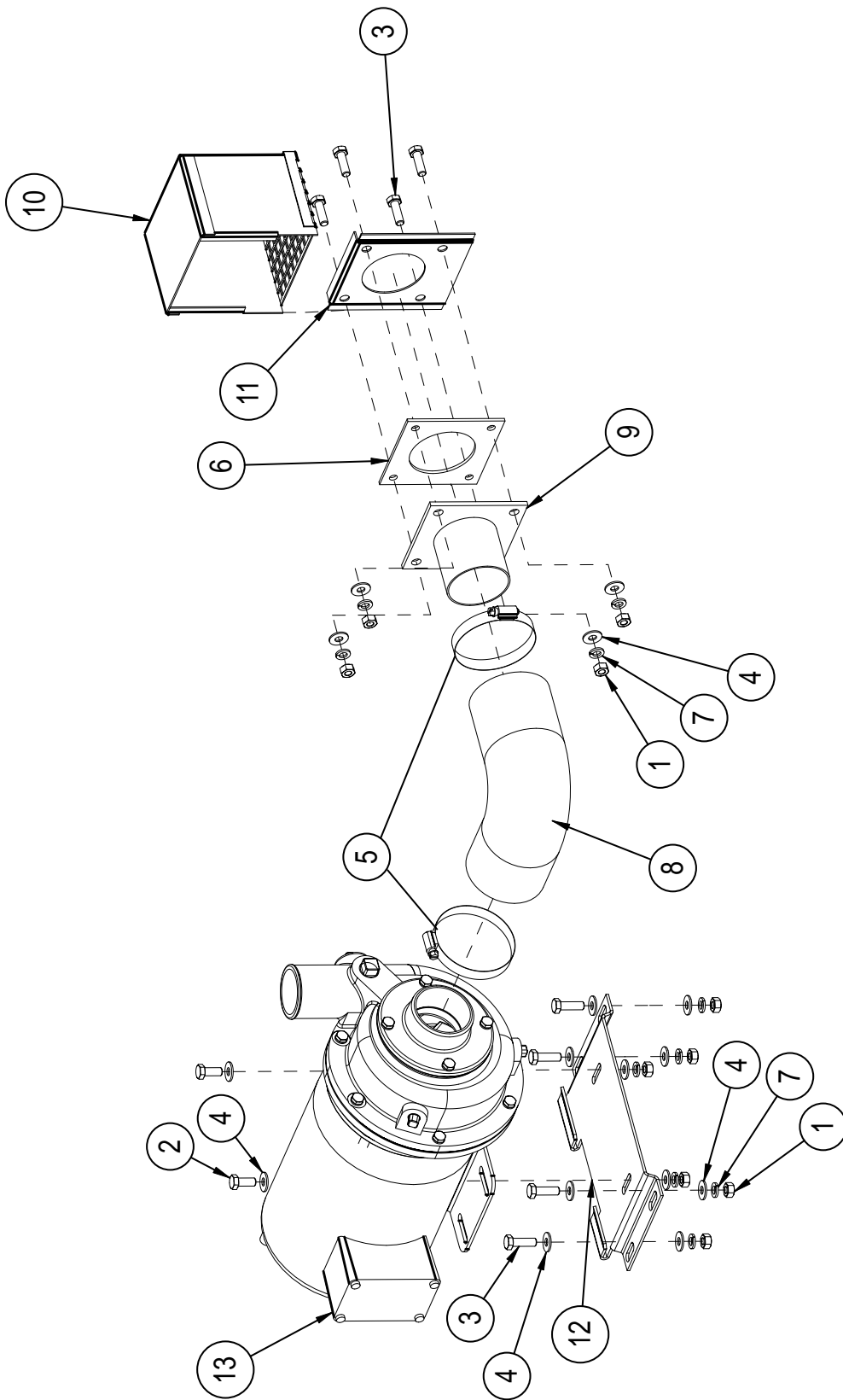

Item No.	Part No.	Description	Qty.
1	100154	HEX PLAIN NUT,5/16-18 SST	10
2	100739	HEX HEAD,5/16-18 X 3/4 SST	2
3	100740	HEX HEAD,5/16-18 X 1 SS T	8
4	102376	WASHER,FLAT,5/16 x 3/4 x.06 SST	16
5	104203	CLAMP,HOSE,M52,71/95,SST GEAR TYPE	2
6	104640	GASKET,PUMP SUCTION RACK/CC/UC	1
7	106013	WASHER,LOCK,5/16 SPLIT,SST	10
8	110372	HOSE,PUMP SUCTION,UC	1
9	313300	FLANGE WELD,PUMP SUCTION,UC	1
10	319742	HOOD WELDMENT,PUMP SUCTION,UC	1
11	319743	PLATE,PUMP SUCTION HOOD	1
12	320918	SUPPORT,PUMP MOTOR,C3 NUCCW	1
13	405923	PUMP ASSY,3HP MV 3PH, UC B4 / C3 / C4 EUCCW	1
---	---	PUMP ASSY,3HP MV 3PH, UC B4 / C4 EUCC	1
---	405922	PUMP ASSY,3HP MV 3PH, UC C3 EUCC	1
	415920	PUMP ASSY, 3HP, 575/60/3 LH, UC B4/C3 EUCCW	
	415921	PUMP ASSY, 3HP, 575/60/3 RH, UC B4/C4 EUCC	

# 1HP, B-30 Prewash Right-Left Pump Installation

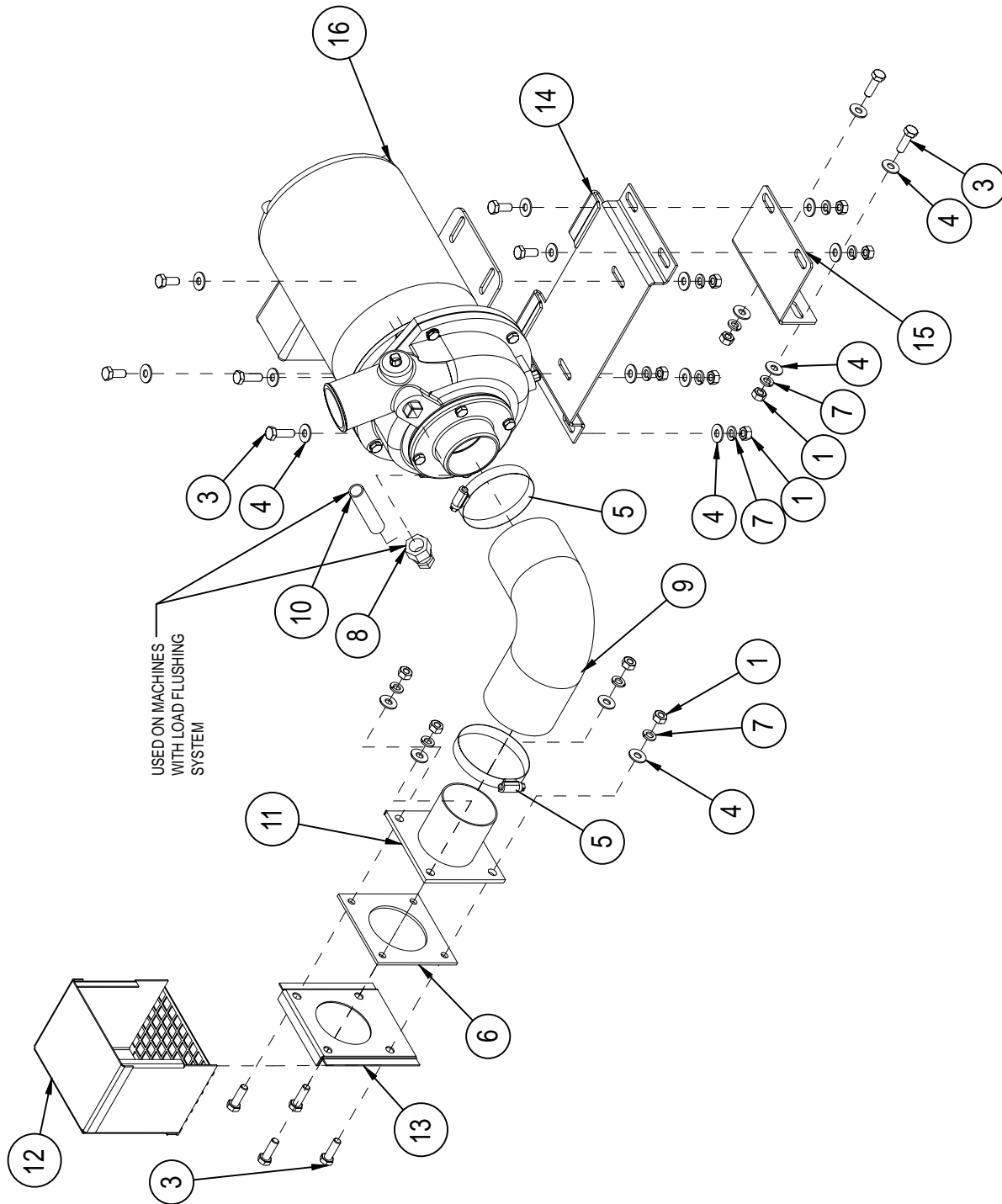



1HP, B-30 Prewash Right-Left Pump Installation

Item No.	Part No.	Description	Qty.
1	100154	HEX PLAIN NUT,5/16-18 SST	12
2	100739	HEX HEAD,5/16-18 X 3/4 SST	4
3	100740	HEX HEAD,5/16-18 X 1 SST	8
4	102376	WASHER,FLAT,5/16x3/4x.06 SST	20
5	104203	CLAMP,HOSE,SST GEAR TYPE	2
6	104640	GASKET,PUMP SUCTION RACK/CC/UC	1
7	106013	WASHER,LOCK,5/16 SPLIT,SST	12
8	109926	FITTING,COMPRESSION,5/8OD X 1/2"MNPT,ELL,BRASS	1
9	110372	HOSE,PUMP SUCTION,UC	1
10	205192	TUBE,1/2"COPPER X 3.00"LG	1
11	313300	FLANGE WELD,PUMP SUCTION,UC	1
12	319742	HOOD WELDMENT,PUMP SUCTION,UC	1
13	319743	PLATE,PUMP SUCTION HOOD	1
14	322150	SUPPORT,PUMP MOTOR,B2 NUCCW	1
15	329618	BRACKET,PUMP SUPPORT,B-30 W/A3	1
16	405919-120	PUMP ASSY,1HP MV 3PH	1
	415917	PUMP ASSY, 1HP, 575/60/3, UC	

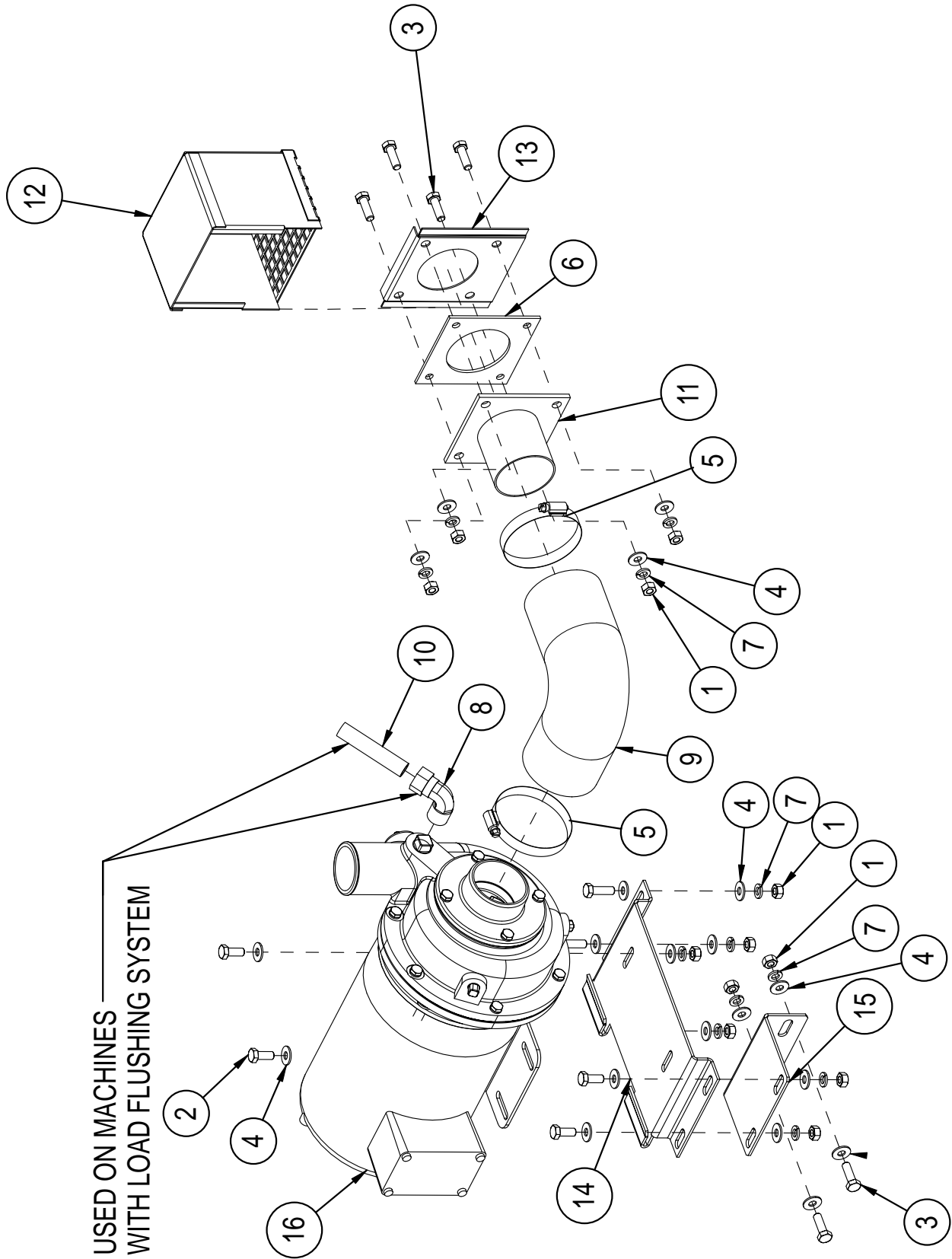

1HP, B-30 Prewash Left-Right Pump Installation

Item No.	Part No.	Description	Qty.
1	100154	HEX PLAIN NUT,5/16-18 SST	12
2	100739	HEX HEAD,5/16-18 X 3/4 SST	4
3	100740	HEX HEAD,5/16-18 X 1 SST	8
4	102376	WASHER,FLAT,5/16x3/4x.06 SST	20
5	104203	CLAMP,HOSE,M52,71/95,SST GEAR TYPE	2
6	104640	GASKET,PUMP SUCTION RACK/CC/UC	1
7	106013	WASHER,LOCK,5/16 SPLIT,SST	12
8	109926	FITTING,COMPRESSION,5/8OD X 1/2"MNPT,ELL,BRASS	1
9	110372	HOSE,PUMP SUCTION,UC	1
10	205192	TUBE,1/2"COPPER X 3.00"LG	1
11	313300	FLANGE WELD,PUMP SUCTION,UC	1
12	319742	HOOD WELDMENT,PUMP SUCTION,UC	1
13	319743	PLATE,PUMP SUCTION HOOD	1
14	322150	SUPPORT,PUMP MOTOR,B2 NUCCW	1
15	329618	BRACKET,PUMP SUPPORT,B-30 W/A3	1
16	405919	PUMP ASSY,1HP MV 3PH, UC	1
	415917	PUMP ASSY, 1HP, 575/60/3	

3HP, B-30 Prewash Left-Right Pump Installation

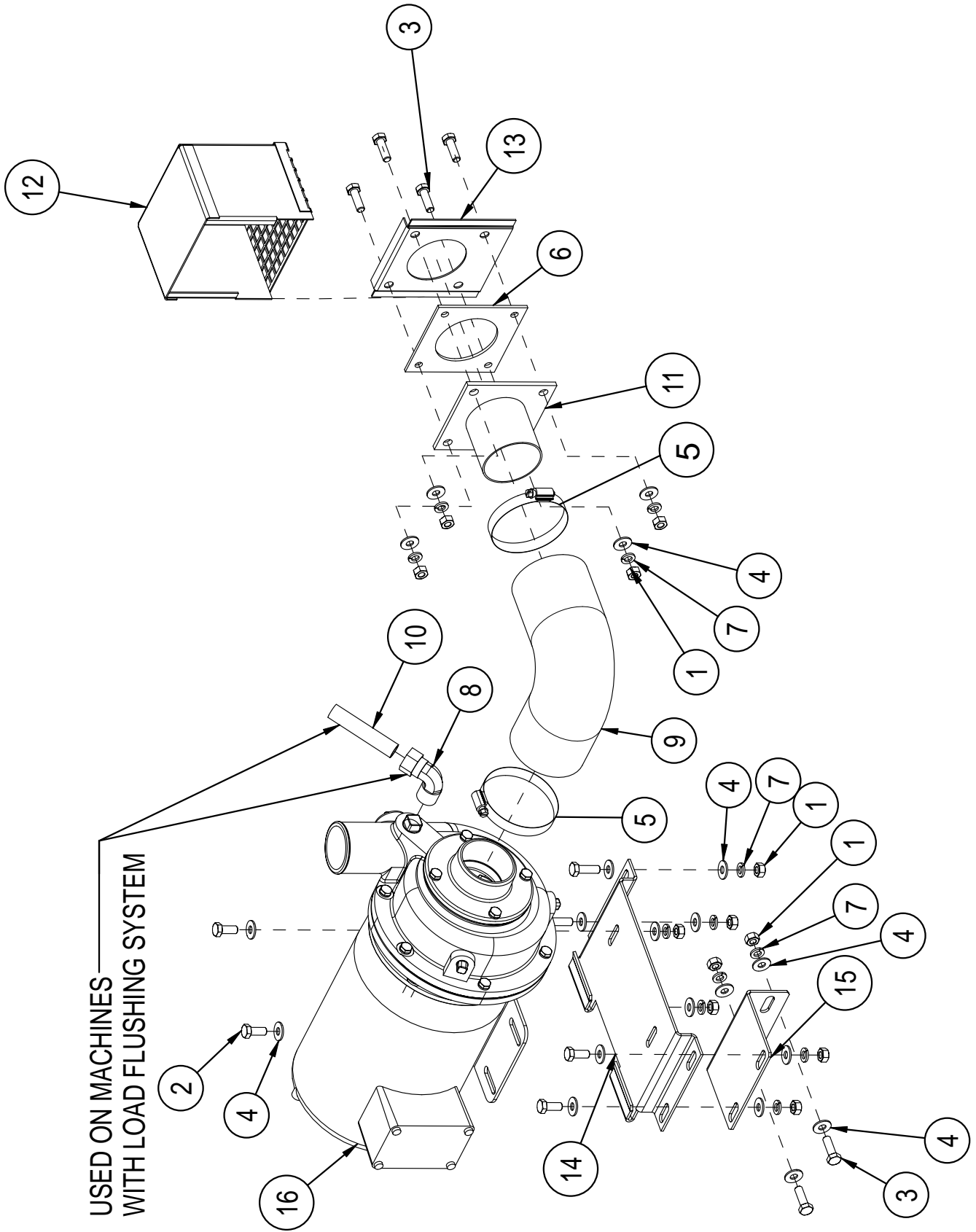

3HP, B-30 Prewash Left-Right Pump Installation

Item No.	Part No.	Description	Qty.
1	100154	HEX PLAIN NUT,5/16-18 SST	12
2	100739	HEX HEAD,5/16-18 X 3/4 SST	4
3	100740	HEX HEAD,5/16-18 X 1 SST	8
4	102376	WASHER,FLAT,5/16x3/4x.06 SST	20
5	104203	CLAMP,HOSE,M52,71/95,SST GEAR TYPE	2
6	104640	GASKET,PUMP SUCTION RACK/CC/UC	1
7	106013	WASHER,LOCK,5/16 SPLIT,SST	12
8	109926	FITTING,COMPRESSION,5/8OD X 1/2"MNPT,ELL,BRASS	1
9	110372	HOSE,PUMP SUCTION,UC	1
10	205192	TUBE,1/2"COPPER X 3.00"LG	1
11	313300	FLANGE WELD,PUMP SUCTION,UC	1
12	319742	HOOD WELDMENT,PUMP SUCTION,UC	1
13	319743	PLATE,PUMP SUCTION HOOD	1
14	322150	SUPPORT,PUMP MOTOR,B2 NUCCW	1
15	329618	BRACKET,PUMP SUPPORT,B-30 W/A3	1
16	405923	PUMP ASSY,3HP MV 3PH, UC	1
	415920	PUMP ASSY, 3HP, 575/60/3 LH, UC B4/C3 EUCCW	
	415921	PUMP ASSY, 3HP, 575/60/3 RH, UC B4/C3 EUCC	

3HP, B-30 Prewash Right-Left Pump Installation

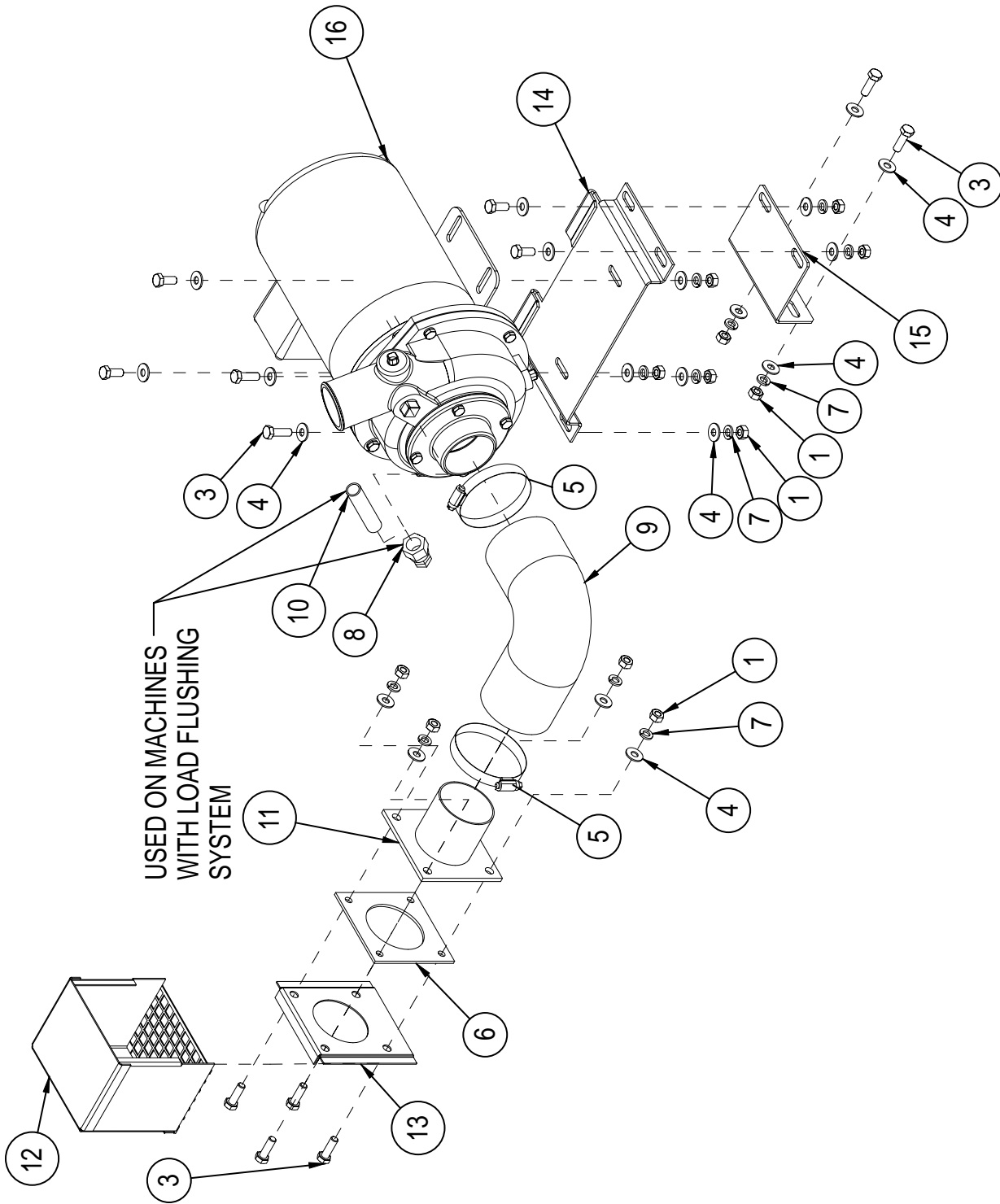

3HP, B-30 Prewash Right-Left Pump Installation

Item No.	Part No.	Description	Qty.
1	100154	HEX PLAIN NUT,5/16-18 SST	12
2	100739	HEX HEAD,5/16-18 X 3/4 SST	4
3	100740	HEX HEAD,5/16-18 X 1 SST	8
4	102376	WASHER,FLAT,5/16x3/4x.06 SST	20
5	104203	CLAMP,HOSE,M52,71/95,SST GEAR TYPE	2
6	104640	GASKET,PUMP SUCTION RACK/CC/UC	1
7	106013	WASHER,LOCK,5/16 SPLIT,SST	12
8	109926	FITTING,COMPRESSION,5/8OD X 1/2"MNPT,ELL,BRASS	1
9	110372	HOSE,PUMP SUCTION,UC	1
10	205192	TUBE,1/2"COPPER X 3.00"LG	1
11	313300	FLANGE WELD,PUMP SUCTION,UC	1
12	319742	HOOD WELDMENT,PUMP SUCTION,UC	1
13	319743	PLATE,PUMP SUCTION HOOD	1
14	322150	SUPPORT,PUMP MOTOR,B2 NUCCW	1
15	329618	BRACKET,PUMP SUPPORT,B-30 W/A3	1
16	405923-120	PUMP ASSY,3HP MV 3PH, UC	1
	405920	PUMP ASSY, 3HP, 575/60/3 LH, UC B4/C3 EUCCW	
	405921	PUMP ASSY, 3HP, 575/60/3 RH, UC B4/C3 EUCCW	

Auxiliary Rinse Right-Left Pump Installation

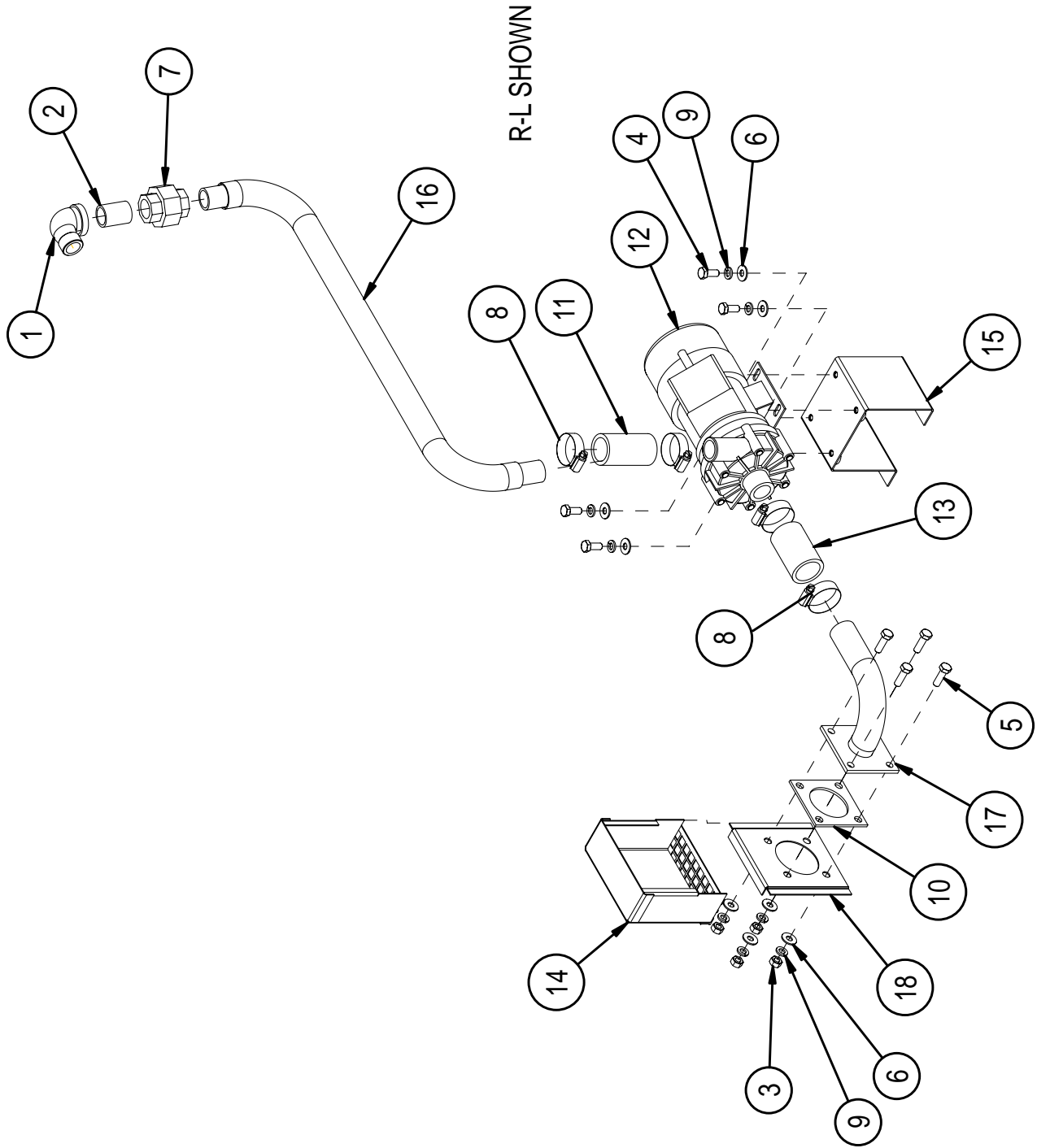



Item No.	Part No.	Description	Qty.
1	100023	STREET ELBOW,3/4"NPT X 90,SST	1
2	100051	NIPPLE,3/4"NPT X CLOSE,SST	1
3	100154	HEX PLAIN NUT,5/16-18 SST	4
4	100739	HEX HEAD,5/16-18 X 3/4 SST	4
5	100740	HEX HEAD,5/16-18 X 1 SST	4
6	102376	WASHER,FLAT,5/16x3/4x.06 SST	8
7	102554	UNION,3/4"NPT, SST	1
8	105993	CLAMP,HOSE,M20,19/44,SST GEAR TYPE	4
9	106013	WASHER,LOCK,5/16 SPLIT,SST	8
10	108345	GASKET,HEATER/STANDPIPE	1
11	114020	HOSE, 1 1/8"ID x 2 3/4" x 3/16" WALL	1
12	114199	PUMP ASSY AUXILIARY	1
---	0509303	KIT, PUMP BODY	1
---	0510222	KIT, SEAL AND GASKET	1
---	180413	IMPELLER	1
13	206643	HOSE,1.250 ID X 2.500 LG.EPDM	1
14	322832	HOOD WELDMENT,PUMP SUCTION,E2	1
15	329791	BASE DECK WELD,PUMP,E2	1
16	329796	TUBE WELDMENT,E2 PUMP DISCHARGE EUCCW	1
---	330750	TUBE WELDMENT,E2 PUMP DISCHARGE EUCC	1
17	329797	FLANGE WELD,E2 PUMP SUCTION	1
18	329798	PLATE,PUMP SUCTION HOOD,E2	1
	111744	MOTOR, AUXILIARY, 1/4 HP, 575/60/3	
	452611	PUMP ASSY, AUXILIARY, 1/4 HP, 575/60/3	

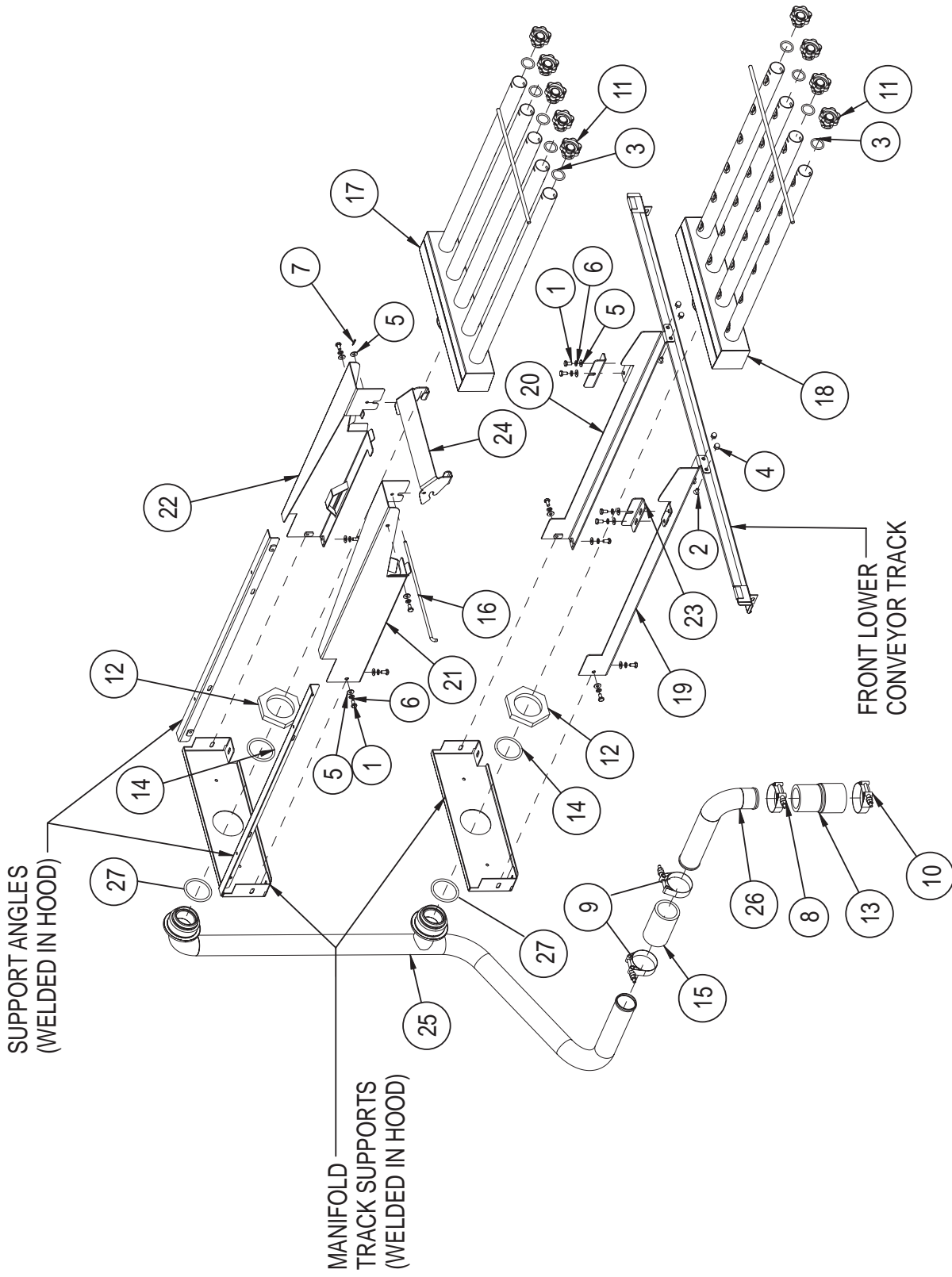

Item No.	Part No.	Description	Qty.
1	100734	HEX HEAD,1/4-20 X 1/2 SST	14
2	100755	SCREW,FLAT HEAD,1/4-20 X 1/2 SST	4
3	104414	O-RING,1 X 1 1/4 X 1/8	9
4	106014	HEX ACORN PLAIN NUT,1/4-20 SST	4
5	106026	WASHER,FLAT,1/4x5/8x.06 SST	15
6	106482	WASHER,LOCK,1/4 SPLIT,SST	14
7	108875	COTTER PIN,3/32 X 1/2 UNEVEN	1
8	110858	HOSE CLAMP,HIGH PRESSURE,0256	1
9	111780	HOSE CLAMP,HIGH PRESSURE,0238	2
10	111964	HOSE CLAMP,HIGH PRESSURE,0275	1
11	112240	PLUG, DEBOSSSED SPRAYPIPE	9
12	113911	LOCKNUT,2 1/2" , NPSL, SST	2
13	113984	HOSE, DISCHARGE MOLDED E	1
14	114096	O-RING,2.225x.210 DIA.	2
15	202146	HOSE,1.875 ID X 5.375 LG.EPDM	1
16	206552	ROD, LATCH PIVOT,5 HOLE MANIFOLD	1
17	329659	MANIFOLD WELDMENT,5 HOLE,UPPER EUCCW	1
---	330632	MANIFOLD WELDMENT,5 HOLE,UPPER EUCC	1
18	329662	MANIFOLD WELDMENT,4 HOLE,LOWER EUCCW	1
---	330633	MANIFOLD WELDMENT,4 HOLE,LOWER EUCC	1
19	329669	TRACK WELDMENT, LH LOWER, MANIFOLD EUCCW	1
---	330644	TRACK WELDMENT, LH LOWER, MANIFOLD EUCC	1
20	329670	TRACK WELDMENT, RH LOWER, MANIFOLD EUCCW	1
---	330645	TRACK WELDMENT, RH LOWER, MANIFOLD EUCC	1
21	329672	TRACK WELDMENT, LH UPPER, MANIFOLD EUCCW	1
---	330641	TRACK WELDMENT, LH UPPER, MANIFOLD EUCC	1
22	329673	TRACK WELDMENT, RH UPPER, MANIFOLD EUCCW	1
---	330642	TRACK WELDMENT, RH UPPER, MANIFOLD EUCC	1
23	329674	BRACKET, LOWER MANIFOLD LATCH	2
24	329704	LATCH DEVP, UPPER MANIFOLD,5 HOLE	1
25	330680	STANDPIPE WELDMENT, C4	1
26	330838	TUBE, PUMP DISCHARGE, WELDMENT EUCCW	1
---	330639	TUBE, PUMP DISCHARGE, WELDMENT EUCC	1
27	114692	GASKET, STANDPIPE	2

1HP 30" Prewash Right-Left Wash System Installation

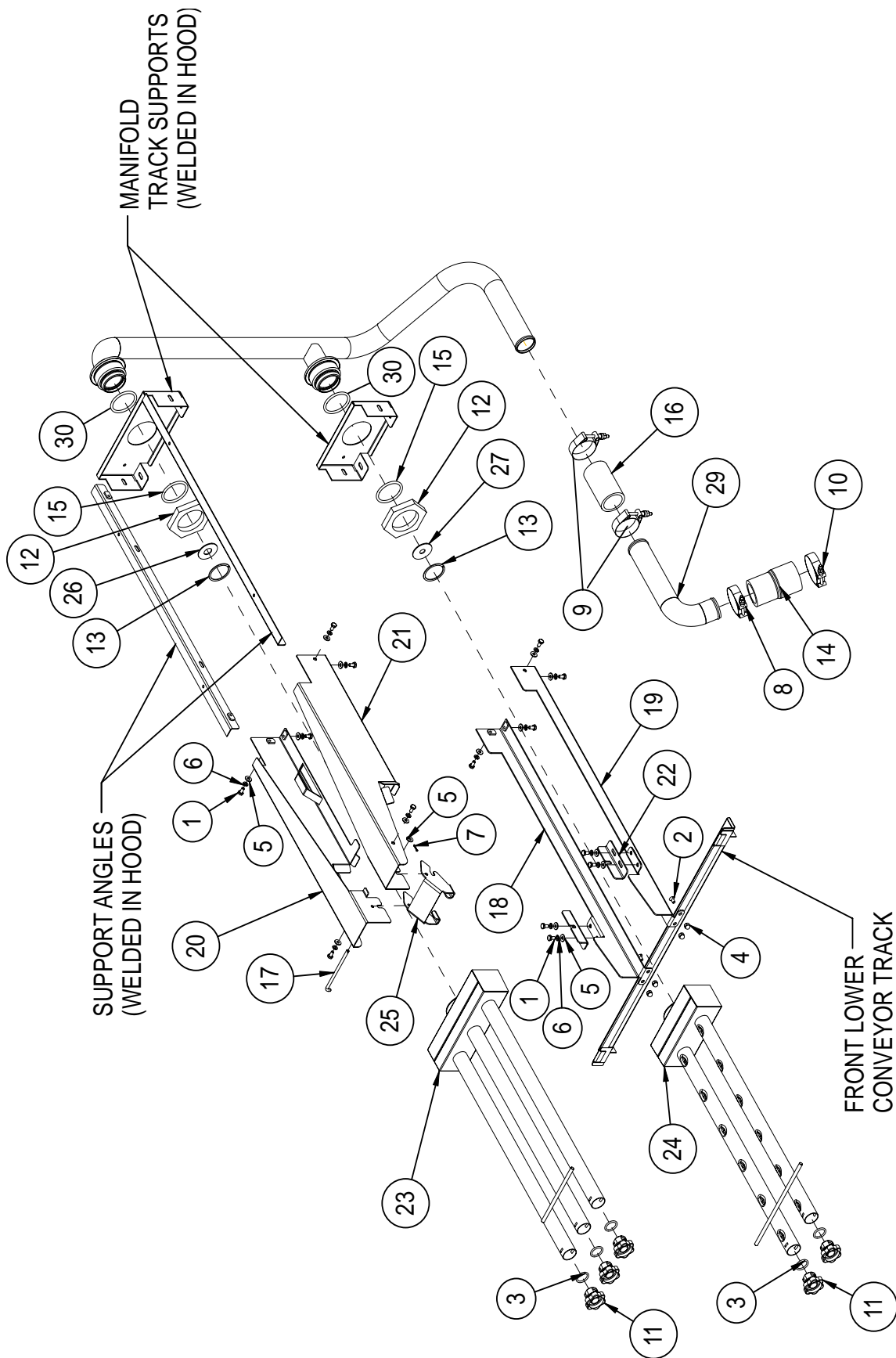

1HP 30" Prewash Right-Left Wash System Installation

Item No.	Part No.	Description	Qty.
1	100734	HEX HEAD,1/4-20 X 1/2 SST	14
2	100755	SCREW,FLAT HEAD,1/4-20 X 1/2 SST	4
3	104414	O-RING,1 X 1 1/4 X 1/8	5
4	106014	HEX ACORN PLAIN NUT,1/4-20 SST	4
5	106026	WASHER,FLAT,1/4x5/8x.06 SST	15
6	106482	WASHER,LOCK,1/4 SPLIT,SST	14
7	108875	COTTER PIN,3/32 X 1/2 UNEVEN	1
8	110858	HOSE CLAMP,HIGH PRESSURE,0256	1
9	111780	HOSE CLAMP,HIGH PRESSURE,0238	2
10	111964	HOSE CLAMP,HIGH PRESSURE,0275	1
11	112240	PLUG, DEBOSSSED SPRAYPIPE	5
12	113911	LOCKNUT,2 1/2" , NPSL, SST	2
13	113912	RETAINING RING, INTERNAL, 2" BORE	2
14	113984	HOSE, DISCHARGE MOLDED E	1
15	114096	O-RING,2.225x.210 DIA.	2
16	202146	HOSE,1.875 ID X 5.375 LG.EPDM	1
17	206553	ROD, LATCH PIVOT,3 HOLE MANIFOLD	1
18	329669	TRACK WELDMENT, LH LOWER, MANIFOLD EUCCW	1
---	330644	TRACK WELDMENT, LH LOWER, MANIFOLD EUCC	1
19	329670	TRACK WELDMENT, RH LOWER, MANIFOLD EUCCW	1
---	330645	TRACK WELDMENT, RH LOWER, MANIFOLD EUCC	1
20	329672	TRACK WELDMENT, LH UPPER, MANIFOLD EUCCW	1
---	330641	TRACK WELDMENT, LH UPPER, MANIFOLD EUCC	1
21	329673	TRACK WELDMENT, RH UPPER, MANIFOLD EUCCW	1
---	330642	TRACK WELDMENT, RH UPPER, MANIFOLD EUCC	1
22	329674	BRACKET, LOWER MANIFOLD LATCH	2
23	329696	MANIFOLD WELDMENT,3 HOLE,UPPER EUCCW	1
---	330637	MANIFOLD WELDMENT,3 HOLE,UPPER EUCC	1
24	329699	MANIFOLD WELDMENT,2 HOLE,LOWER EUCCW	1
---	330638	MANIFOLD WELDMENT,2 HOLE,LOWER EUCC	1
25	329705	LATCH DEVP, UPPER MANIFOLD,3 HOLE	1
26	330308	MANIFOLD RESTRICTOR, 0.781" ID	1
27	330309	MANIFOLD RESTRICTOR, 0.531" ID	1
28	330698	STANDPIPE WELDMENT,B-30 RL	1
29	330838	TUBE, PUMP DISCHARGE, WELDMENT EUCCW	1
---	330679	TUBE, PUMP DISCHARGE, WELDMENT EUCC	1
30	114692	GASKET, STANDPIPE	2

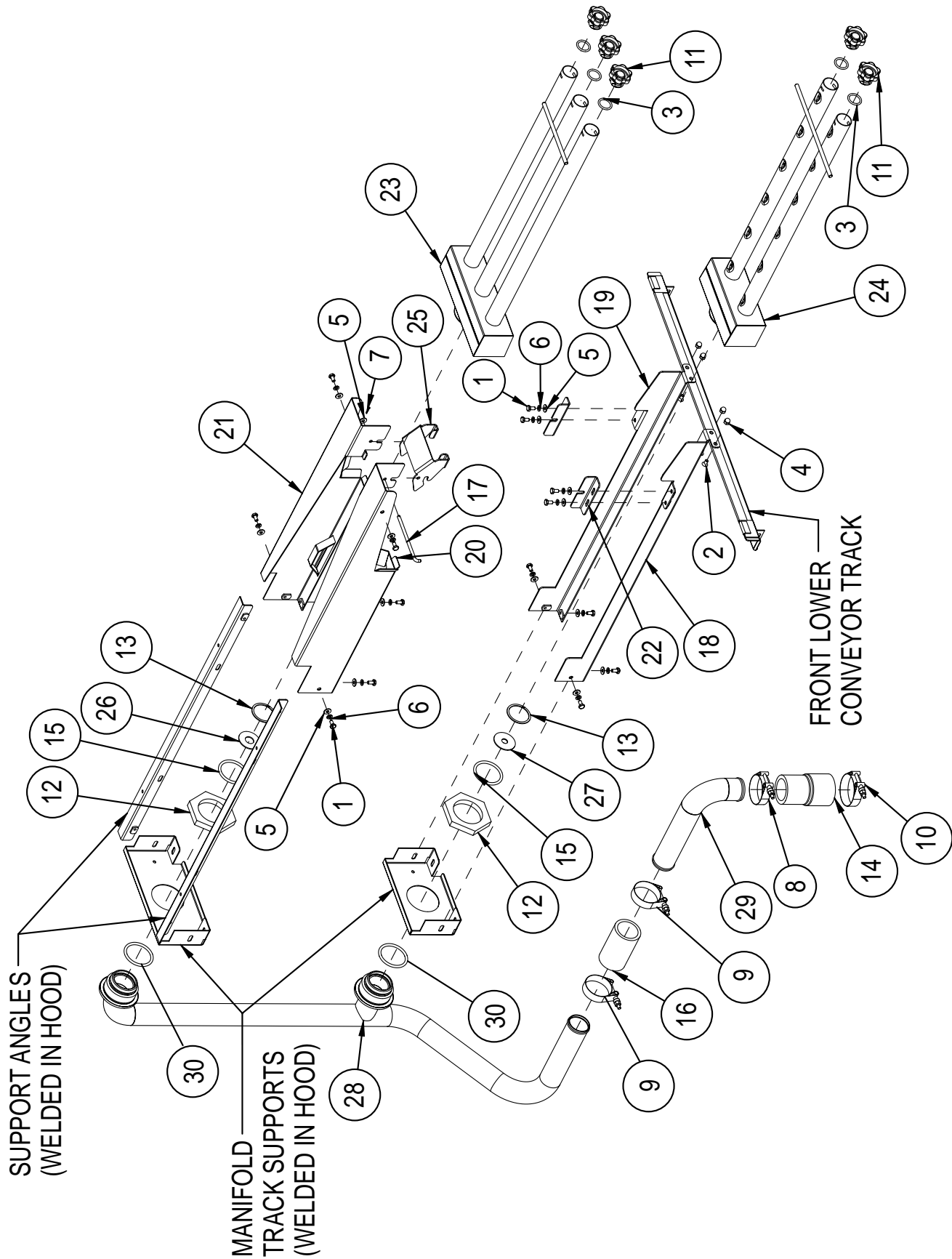

1HP 30" Prewash Left-Right Wash System Installation

Item No.	Part No.	Description	Qty.
1	100734	CAP SCREW,HEX HEAD,1/4-20 X 1/2 SST	14
2	100755	SCREW,FLAT HEAD,1/4-20 X 1/2 SST	4
3	104414	O-RING,1 X 1 1/4 X 1/8	5
4	106014	HEX ACORN PLAIN NUT,1/4-20 SST	4
5	106026	WASHER,FLAT,1/4x5/8x.06 SST	15
6	106482	WASHER,LOCK,1/4 SPLIT,SST	14
7	108875	COTTER PIN,3/32 X 1/2 UNEVEN	1
8	110858	HOSE CLAMP,HIGH PRESSURE,0256	1
9	111780	HOSE CLAMP,HIGH PRESSURE,0238	2
10	111964	HOSE CLAMP,HIGH PRESSURE,0275	1
11	112240	PLUG, DEBOSSSED SPRAYPIPE	5
12	113911	LOCKNUT,2 1/2" , NPSL, SST	2
13	113912	RETAINING RING, INTERNAL, 2" BORE	2
14	113984	HOSE, DISCHARGE MOLDED E	1
15	114096	O-RING,2.225x.210 DIA.	2
16	202146	HOSE,1.875 ID X 5.375 LG.EPDM	1
17	206553	ROD, LATCH PIVOT,3 HOLE MANIFOLD	1
18	329669	TRACK WELDMENT, LH LOWER, MANIFOLD EUCCW	1
---	329669	TRACK WELDMENT, LH LOWER, MANIFOLD EUCC	1
19	330642	TRACK WELDMENT, RH LOWER, MANIFOLD EUCCW	1
---	329670	TRACK WELDMENT, RH LOWER, MANIFOLD EUCC	1
20	329672	TRACK WELDMENT, LH UPPER, MANIFOLD EUCCW	1
---	330645	TRACK WELDMENT, LH UPPER, MANIFOLD EUCC	1
21	329673	TRACK WELDMENT, RH UPPER, MANIFOLD EUCCW	1
---	330641	TRACK WELDMENT, RH UPPER, MANIFOLD EUCC	1
22	329674	BRACKET, LOWER MANIFOLD LATCH	2
23	329696	MANIFOLD WELDMENT,3 HOLE,UPPER EUCCW	1
---	330637	MANIFOLD WELDMENT,3 HOLE,UPPER EUCC	1
24	329699	MANIFOLD WELDMENT,2 HOLE,LOWER EUCCW	1
---	330638	MANIFOLD WELDMENT,2 HOLE,LOWER EUCC	1
25	329705	LATCH DEVP, UPPER MANIFOLD,3 HOLE	1
26	330308	MANIFOLD RESTRICTOR, 0.781" ID	1
27	330309	MANIFOLD RESTRICTOR, 0.531" ID	1
28	330699	STANDPIPE WELDMENT,B-30 LR	1
29	330838	TUBE, PUMP DISCHARGE, WELDMENT EUCCW	1
---	330639	TUBE, PUMP DISCHARGE, WELDMENT EUCC	1
30	114692	GASKET, STANDPIPE	2

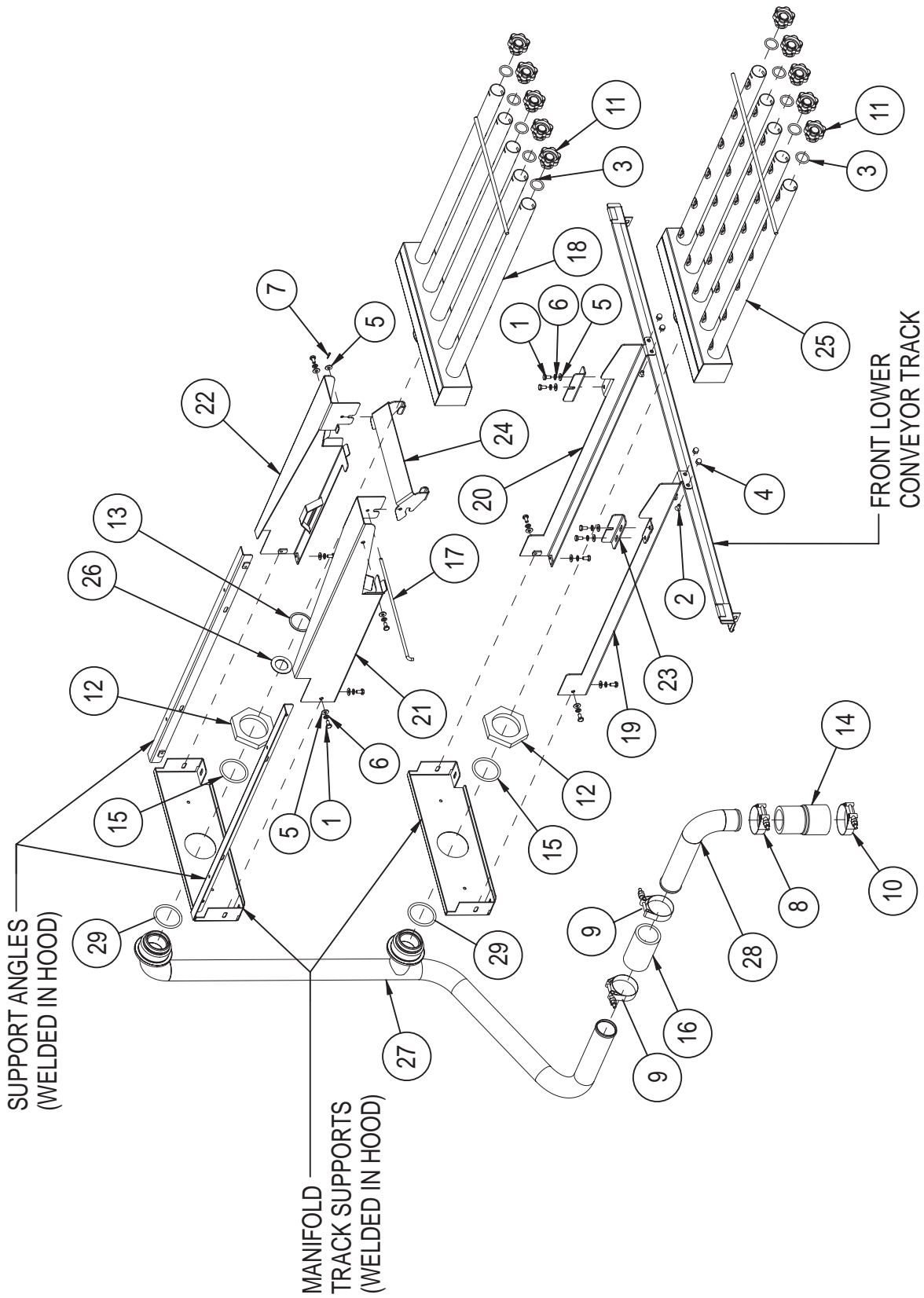



Item No.	Part No.	Description	Qty.
1	100734	HEX HEAD,1/4-20 X 1/2 SST	14
2	100755	SCREW,FLAT HEAD,1/4-20 X 1/2 SST	4
3	104414	O-RING,1 X 1 1/4 X 1/8	10
4	106014	HEX ACORN PLAIN NUT,1/4-20 SST	4
5	106026	WASHER,FLAT,1/4x5/8x.06 SST	15
6	106482	WASHER,LOCK,1/4 SPLIT,SST	14
7	108875	COTTER PIN,3/32 X 1/2 UNEVEN	1
8	110858	HOSE CLAMP,HIGH PRESSURE,0256	1
9	111780	HOSE CLAMP,HIGH PRESSURE,0238	2
10	111964	HOSE CLAMP,HIGH PRESSURE,0275	1
11	112240	PLUG, DEBOSSSED SPRAYPIPE	10
12	113911	LOCKNUT,2 1/2" , NPSL, SST	2
13	113912	RETAINING RING, INTERNAL, 2" BORE	1
14	113984	HOSE, DISCHARGE MOLDED E	1
15	114096	O-RING,2.225x.210 DIA.	2
16	202146	HOSE,1.875 ID X 5.375 LG.EPDM	1
17	206552	ROD, LATCH PIVOT,5 HOLE MANIFOLD	1
18	329659	MANIFOLD WELDMENT,5 HOLE,UPPER EUCCW	1
---	329659	MANIFOLD WELDMENT,5 HOLE,UPPER EUCC	1
19	329669	TRACK WELDMENT, LH LOWER, MANIFOLD EUCCW	1
---	330632	TRACK WELDMENT, LH LOWER, MANIFOLD EUCC	1
20	329670	TRACK WELDMENT, RH LOWER, MANIFOLD EUCCW	1
---	330644	TRACK WELDMENT, RH LOWER, MANIFOLD EUCC	1
21	329672	TRACK WELDMENT, LH UPPER, MANIFOLD EUCCW	1
---	330641	TRACK WELDMENT, LH UPPER, MANIFOLD EUCC	1
22	329673	TRACK WELDMENT, RH UPPER, MANIFOLD EUCCW	1
---	330642	TRACK WELDMENT, RH UPPER, MANIFOLD EUCC	1
23	329674	BRACKET, LOWER MANIFOLD LATCH	2
24	329704	LATCH DEVP, UPPER MANIFOLD,5 HOLE	1
25	330467	MANIFOLD WELDMENT,5 HOLE,LOWER- EUCCW	1
---	330467	MANIFOLD WELDMENT,5 HOLE,LOWER- EUCC	1
26	330468	MANIFOLD RESTRICTOR, 1.188" ID	1
27	330680	STANDPIPE WELDMENT, C4	1
28	330838	TUBE, PUMP DISCHARGE, WELDMENT EUCCW	1
---	330838	TUBE, PUMP DISCHARGE, WELDMENT EUCC	1
29	114692	GASKET, STANDPIPE	2

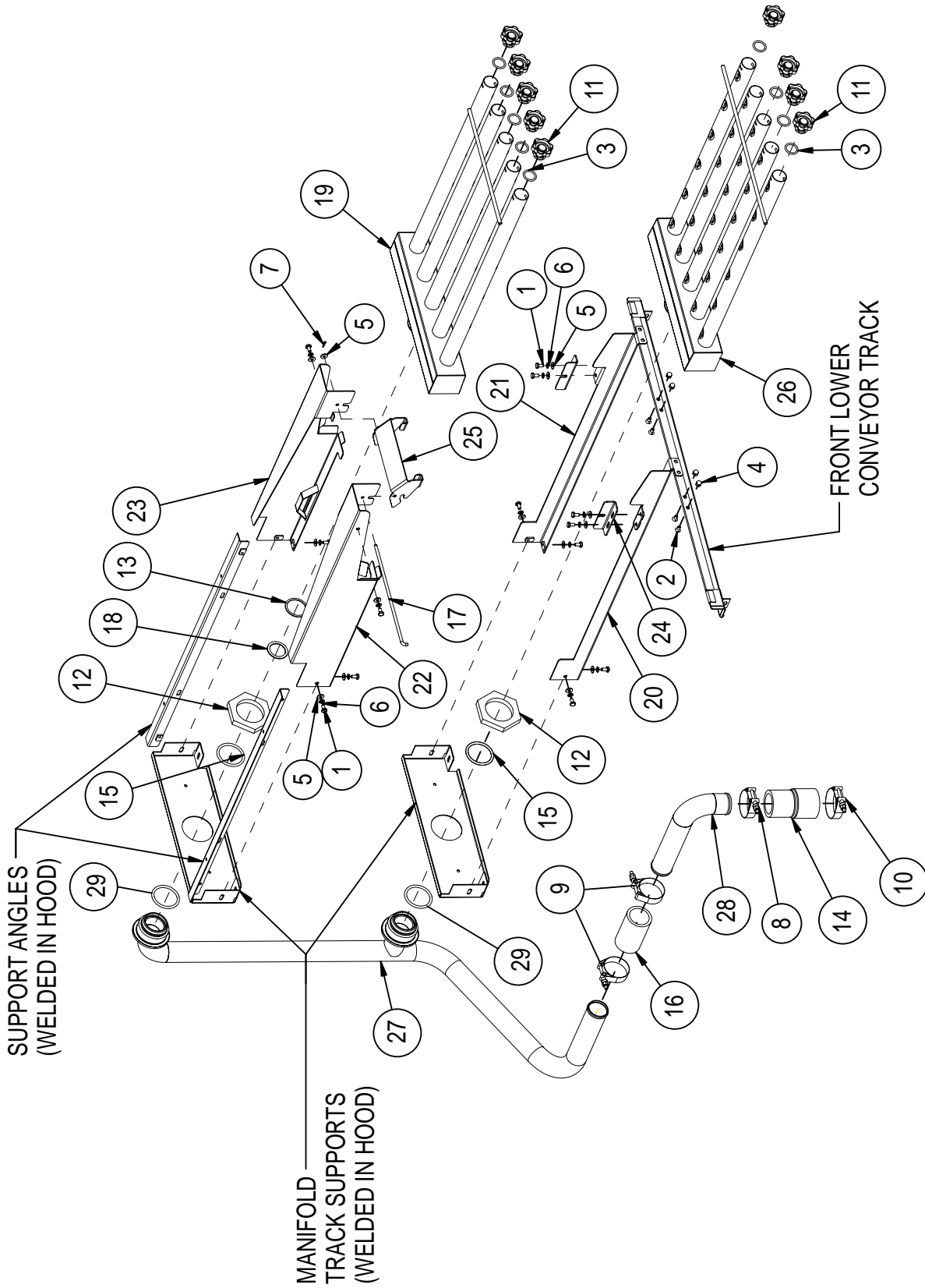

Item No.	Part No.	Description	Qty.
1	100734	HEX HEAD,1/4-20 X 1/2 SST	14
2	100755	SCREW,FLAT HEAD,1/4-20 X 1/2 SST	4
3	104414	O-RING,1 X 1 1/4 X 1/8	9
4	106014	HEX ACORN PLAIN NUT,1/4-20 SST	4
5	106026	WASHER,FLAT,1/4 x 5/8 x .06 SST	15
6	106482	WASHER,LOCK,1/4 SPLIT,SST	14
7	108875	COTTER PIN,3/32 X 1/2 UNEVEN	1
8	110858	HOSE CLAMP,HIGH PRESSURE,0256	1
9	111780	HOSE CLAMP,HIGH PRESSURE,0238	2
10	111964	HOSE CLAMP,HIGH PRESSURE,0275	1
11	112240	PLUG, DEBOSSSED SPRAYPIPE	9
12	113911	LOCKNUT,2 1/2" , NPSL, SST	2
13	113912	RETAINING RING, INTERNAL, 2" BORE	1
14	113984	HOSE, DISCHARGE MOLDED E	1
15	114096	O-RING,2.225x.210 DIA.	2
16	202146	HOSE,1.875 ID X 5.375 LG.EPDM	1
17	206552	ROD, LATCH PIVOT,5 HOLE MANIFOLD	1
18	328861	MANIFOLD RESTRICTOR, 1.5" ID	1
19	329659	MANIFOLD WELDMENT,5 HOLE,UPPER	1
20	329669	TRACK WELDMENT, LH LOWER, MANIFOLD EUCCW	1
21	329670	TRACK WELDMENT, RH LOWER, MANIFOLD EUCCW	1
22	329672	TRACK WELDMENT, LH UPPER, MANIFOLD EUCCW	1
23	329673	TRACK WELDMENT, RH UPPER, MANIFOLD EUCCW	1
24	329674	BRACKET, LOWER MANIFOLD LATCH	2
25	330186	LATCH DEVP, UPPER MANIFOLD,4 HOLE	1
26	330467	MANIFOLD WELDMENT,5 HOLE,LOWER EUCCW	1
27	330680	STANDPIPE WELDMENT, C4	1
28	330838	TUBE, PUMP DISCHARGE, WELDMENT EUCCW	1
---	330639	TUBE, PUMP DISCHARGE, WELDMENT EUCC	1
29	114692	GASKET, STANDPIPE	2

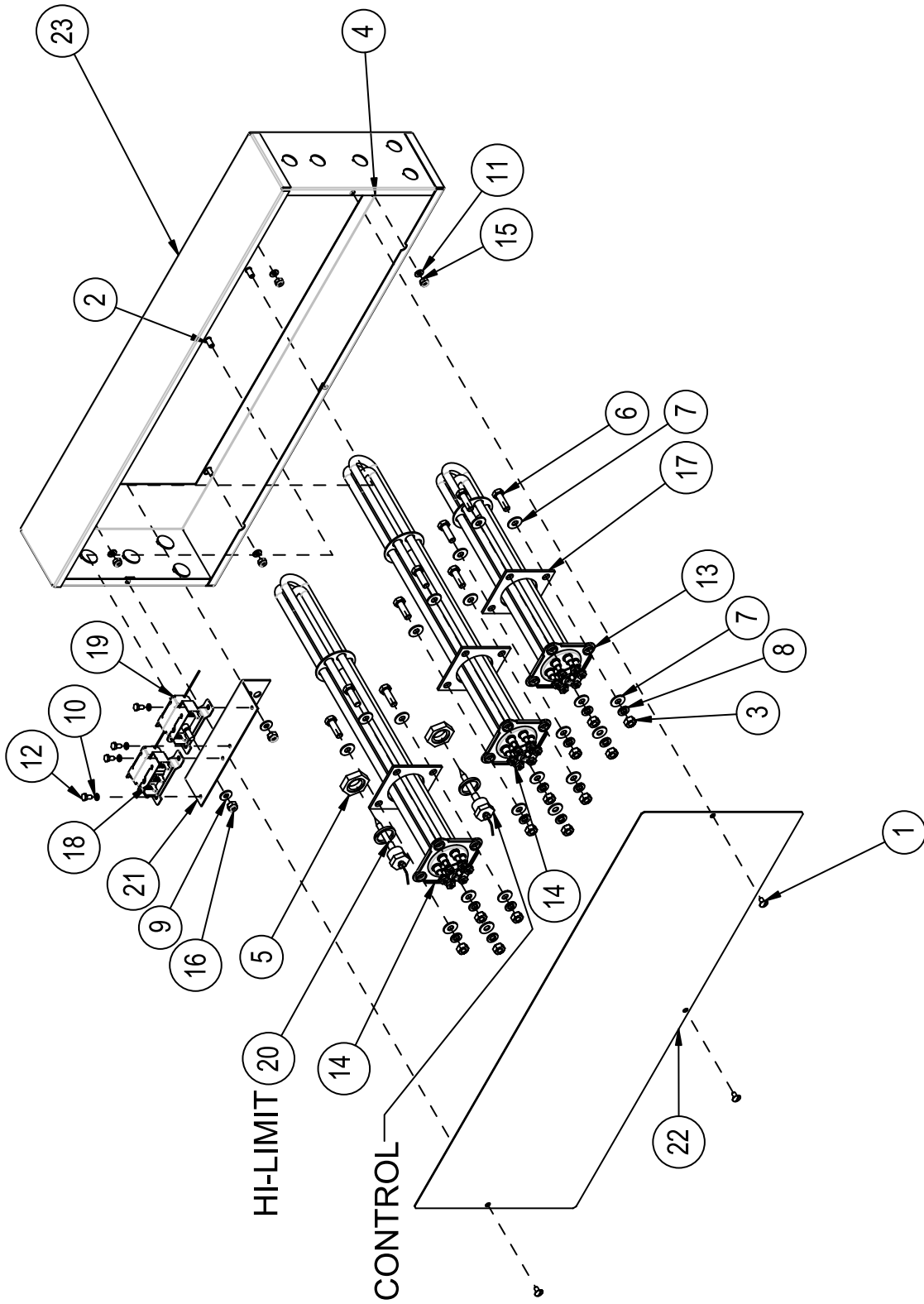

C4 Wash without Scrap Basket Electric Tank Heat Installation

Item No.	Part No.	Description	Qty.
1	100007	SCREW,TRUSS HEAD,10-32 x 3/8 SST	3
2	100109	WELD-STUD,1/4-20 X 1/2 LG.SST	2
3	100154	HEX PLAIN NUT,5/16-18 SST	12
4	100198	WELD-STUD,10-32 X 1/2 LG.SST	4
5	100547	LOCKNUT,1/2" NPT,SST	2
6	100740	CAP SCREW,HEX HEAD,5/16-18 X 1 SST	12
7	102376	WASHER,FLAT,5/16x3/4x.06 SST	24
8	106013	WASHER,LOCK,5/16 SPLIT,SST	12
9	106026	WASHER,FLAT,1/4x5/8x.06 SST	2
10	106486	WASHER,LOCK,#10 SPLIT,SST	4
11	107033	WASHER,FLAT,.208X.438X.047 SST	4
12	107136	SCREW,HEX HEAD,10-32 x 3/8 SST	4
13	107839	TANK HEATER,RICA 5KW 208V/3ph	1
13	107840	TANK HEATER,RICA 5KW 240V/3ph	1
13	107842	TANK HEATER,RICA 5KW 480V/3ph	1
13	111123	TANK HEATER,RICA 5KW 575V/3ph	1
14	107951	TANK HEATER,RICA 10KW 208V/3ph	2
14	107844	TANK HEATER,RICA 10KW 240 V/3ph	2
14	107846	TANK HEATER,RICA 10KW 480 V/3ph	2
14	111120	TANK HEATER,RICA 10KW 575 V/3ph	2
15	107966	HEX GRIP NUT,10-32 SST W/NYLON	4
16	107967	HEX GRIP NUT,1/4-20 SST W/NYLON	2
17	108345	GASKET,HEATER/STANDPIPE	3
18	109069	THERMOSTAT,CONTROL,WITH CAPILLARY	1
19	110561	THERMOSTAT,HI-LIMIT,WITH CAPILLARY	1
20	201041	WASHER,SPACER,7/8x1 3/16x1/8 NP	2
21	323430	BRACKET, THERMOSTATS,USN72,44CR	1
22	329768	COVER,HEATER BOX,C4-BKT	1
23	329769	HEATER BOX WELDMENT,C4-B	1

C4 Rinse without Scrap Basket Electric Tank Heat Installation

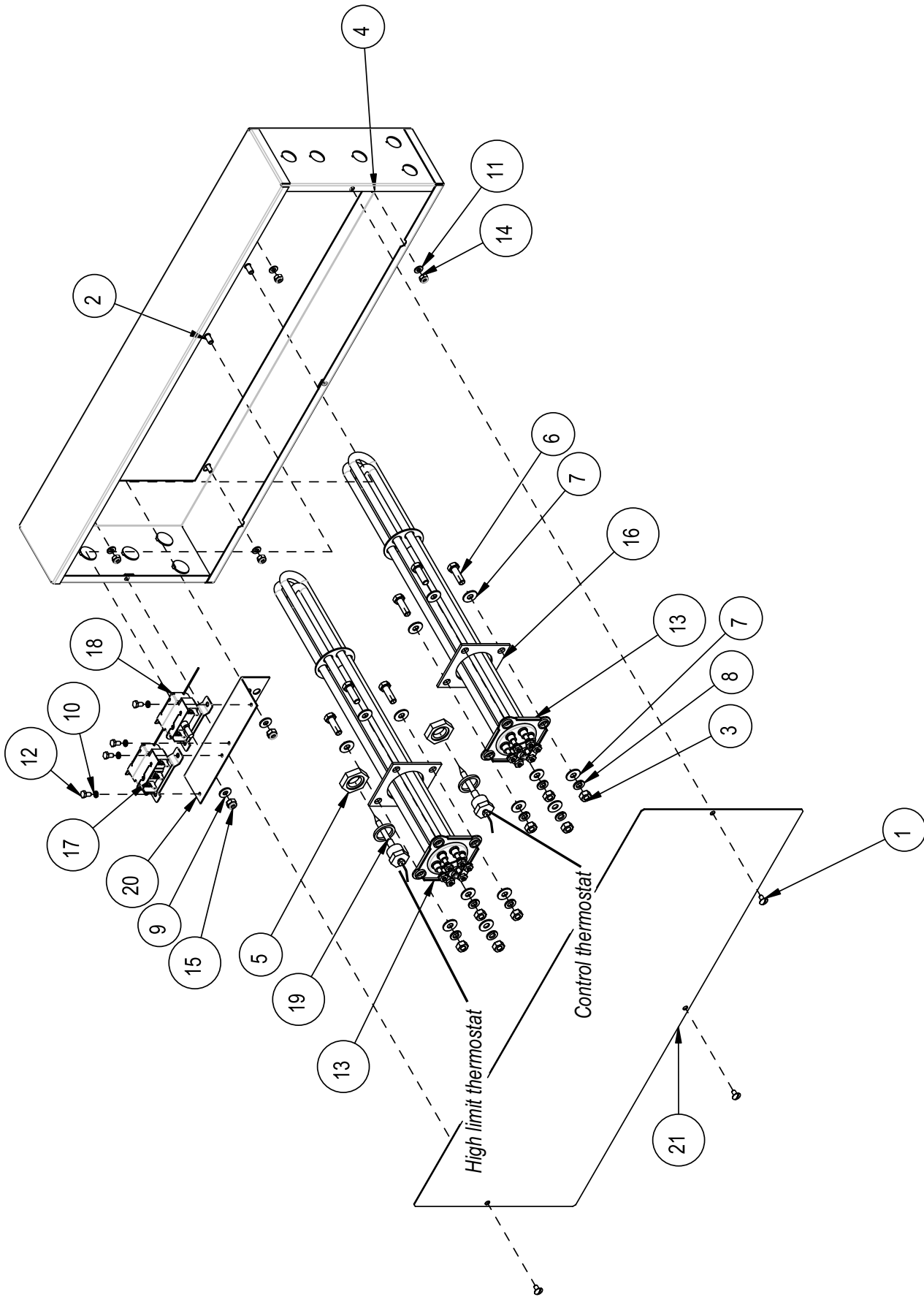

*C4 Rinse without Scrap Basket Electric Tank Heat Installation*

Item No.	Part No.	Description	Qty.
1	100007	SCREW,TRUSS HEAD,10-32 x 3/8 SST	3
2	100109	WELD-STUD,1/4-20 X 1/2 LG.SST	2
3	100154	HEX PLAIN NUT,5/16-18 SST	8
4	100198	WELD-STUD,10-32 X 1/2 LG.SST	4
5	100547	LOCKNUT,1/2" NPT,SST	2
6	100740	HEX HEAD,5/16-18 X 1 SST	8
7	102376	WASHER,FLAT,5/16x3/4x.06 SST	16
8	106013	WASHER,LOCK,5/16 SPLIT,SST	8
9	106026	WASHER,FLAT,1/4x5/8x.06 SST	2
10	106486	WASHER,LOCK,#10 SPLIT,SST	4
11	107033	WASHER,FLAT,.208X.438X.047 SST	4
12	107136	SCREW,HEX HEAD,10-32 x 3/8 SST	4
13	109751	TANK HEATER,RICA 10KW 208V	2
----	107844	TANK HEATER,RICA 10KW 240V	2
----	107846	TANK HEATER,RICA 10KW 480V	2
----	111120	TANK HEATER,RICA 10KW 575V	2
14	107966	HEX GRIP NUT,10-32 SST W/NYLON	4
15	107967	HEX GRIP NUT,1/4-20 SST W/NYLON	2
16	108345	GASKET,HEATER/STANDPIPE	2
17	109069	THERMOSTAT,CONTROL,WITH CAPILLARY	1
18	110561	THERMOSTAT,HI-LIMIT,WITH CAPILLARY	1
19	201041	WASHER,SPACER,7/8x1 3/16x1/8 NP	2
20	323430	BRACKET, THERMOSTATS,USN72,44CR	1
21	329768	COVER,HEATER BOX,C4-BKT	1
22	329769	HEATER BOX WELDMENT,C4-B	1

C4 Wash with Scrap Basket Electric Tank Heat Installation

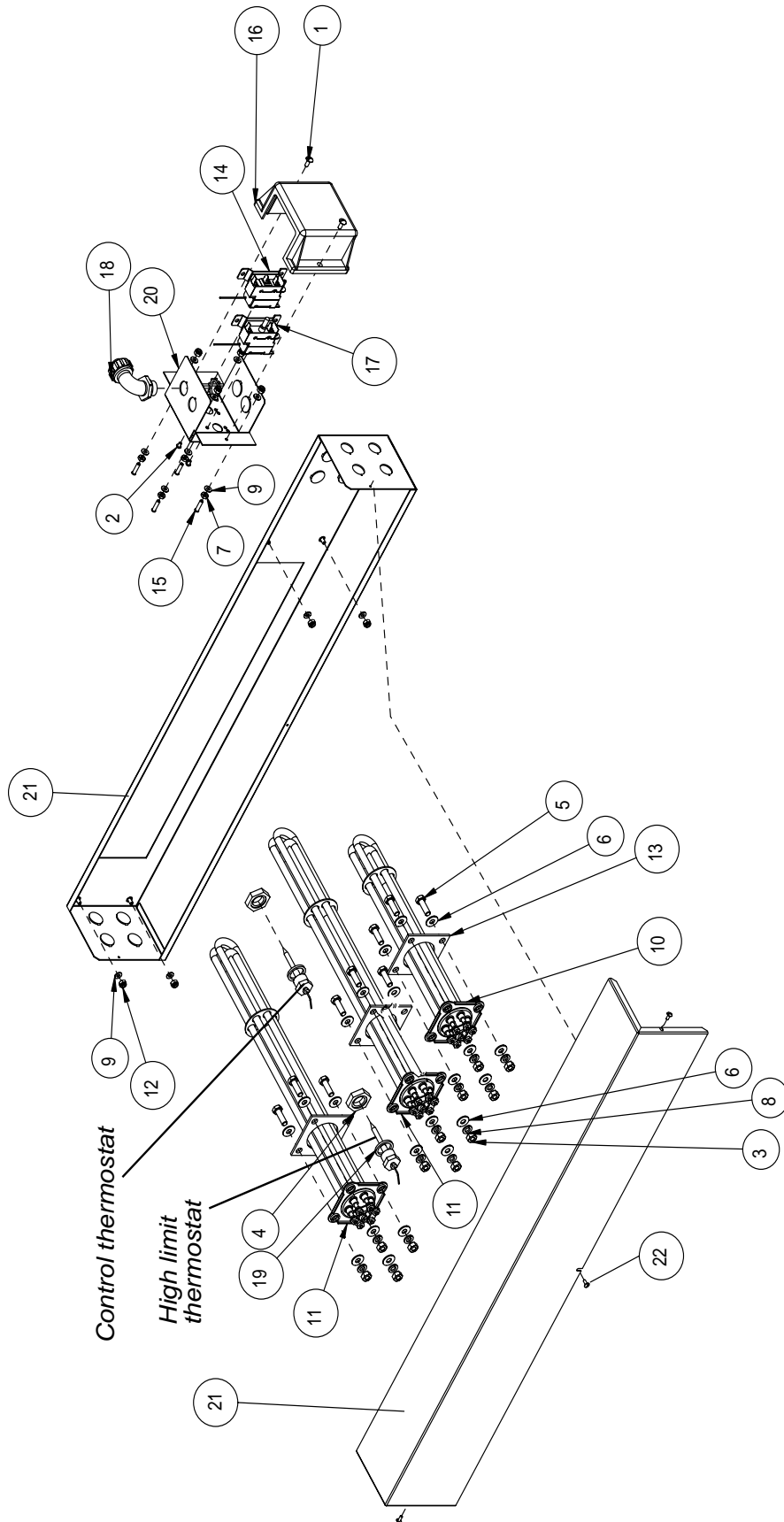



C4 Wash with Scrap Basket Electric Tank Heat Installation

Item No.	Part No.	Description	Qty.
1	100097	SCREW,TRUSS HEAD,10-32 x 1/2 SST	2
2	100100	SCREW,ROUND HEAD,8-32 x 1/4 SST	2
3	100154	HEX PLAIN NUT,5/16-18 SST	12
4	100547	LOCKNUT,1/2" NPT,SST	2
5	100740	HEX HEAD,5/16-18 X 1 SST	12
6	102376	WASHER,FLAT,5/16x3/4x.06 SST	24
7	104985	HEX PLAIN NUT,10-32 SST	4
8	106013	WASHER,LOCK,5/16 SPLIT,SST	12
9	107033	WASHER,FLAT, .208X.438X.047 SST	8
10	107839	TANK HEATER, RICA 5KW 208V 3PH	1
	107840	TANK HEATER, RICA 5KW 240V 3PH	1
	107842	TANK HEATER, RICA 5KW 480V 3PH	1
	111123	TANK HEATER, RICA 5KW 575V 3PH	1
11	107951	TANK HEATER, RICA 10KW 208V 3PH	2
	107844	TANK HEATER, RICA 10KW 240V 3PH	2
	107846	TANK HEATER, RICA 10KW 480V 3PH	2
	111120	TANK HEATER, RICA 10KW 575V 3PH	2
12	107966	HEX GRIP NUT,10-32 SST W/NYLON	4
13	108345	GASKET,HEATER/STANDPIPE	3
14	109069	THERMOSTAT,CONTROL,WITH CAPILLARY	1
15	109165	WELD-STUD,10-32 X 3/4 LG.SST	4
16	109682	THERMOSTAT COVER BOX	1
17	110561	THERMOSTAT,HI-LIMIT,WITH CAPILLARY	1
18	110837	ELBOW,1/2" CONDUIT,SEALTITE	1
19	201041	WASHER,SPACER,7/8x1 3/16x1/8 NP	2
20	314102	BOX,DUAL THERMOSTAT	1
21	453122	HEATER BOX ASS Y,C4+BKT,ELEC	1

C4 Rinse with Scrap Basket Electric Tank Heat Installation

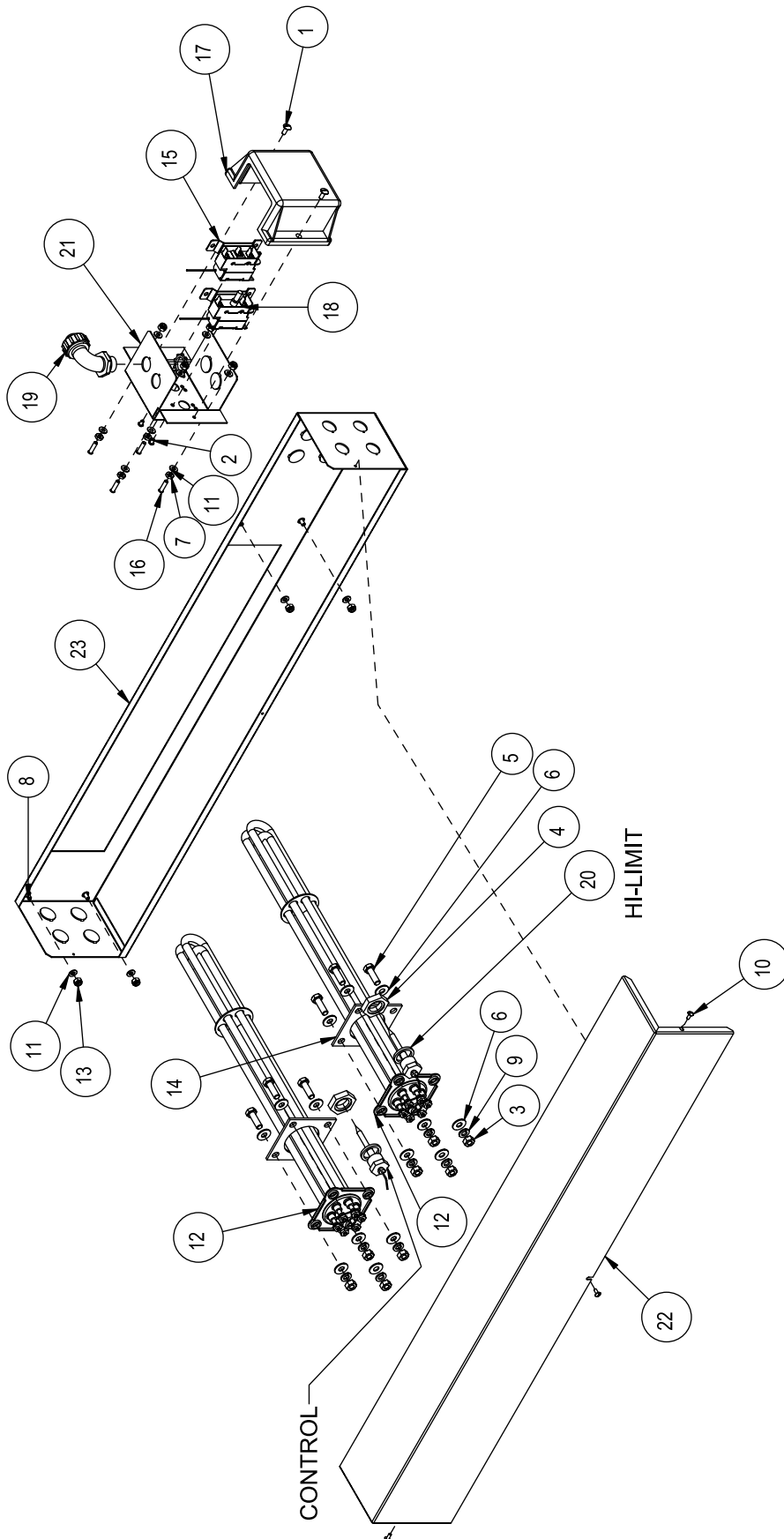

Item No.	Part No.	Description	Qty.
1	100097	SCREW,TRUSS HEAD,10-32 x 1/2 SST	2
2	100100	SCREW,ROUND HEAD,8-32 x 1/4 SST	2
3	100154	HEX PLAIN NUT,5/16-18 SST	8
4	100547	LOCKNUT,1/2" NPT,SST	2
5	100740	HEX HEAD,5/16-18 X 1 SST	8
6	102376	WASHER,FLAT,5/16x3/4x.06 SST	16
7	104985	HEX PLAIN NUT,10-32 SST	4
8	105695	WELD-STUD,10-32 X 3/8 LG.SST	4
9	106013	WASHER,LOCK,5/16 SPLIT,SST	8
10	106382	SCREW,TRUSS HEAD,6-32 x 3/8 SST	3
11	107033	WASHER,FLAT,.208X.438X.047 SST	12
12	109751	TANK HEATER,RICA 10KW 208V	2
----	107844	TANK HEATER,RICA 10KW 240V	2
----	107846	TANK HEATER,RICA 10KW 480V	2
----	111120	TANK HEATER,RICA 10KW 575V	2
13	107966	HEX GRIP NUT,10-32 SST W/NYLON	8
14	108345	GASKET,HEATER/STANDPIPE	2
15	109069	THERMOSTAT,CONTROL,WITH CAPILLARY	1
16	109165	WELD-STUD,10-32 X 3/4 LG.SST	4
17	109682	THERMOSTAT COVER BOX	1
18	110561	THERMOSTAT,HI-LIMIT,WITH CAPILLARY	1
19	110837	ELBOW,1/2" CONDUIT,SEALTITE	1
20	201041	WASHER,SPACER,7/8x1 3/16x1/8 NP	2
21	314102	BOX,DUAL THERMOSTAT	1
22	329766	COVER,HEATER BOX,C4+B,ELEC	1
23	329767	HEATER BOX WELDMENT,C4+B,ELEC	1

Auxiliary Rinse Electric Tank Heat Installation

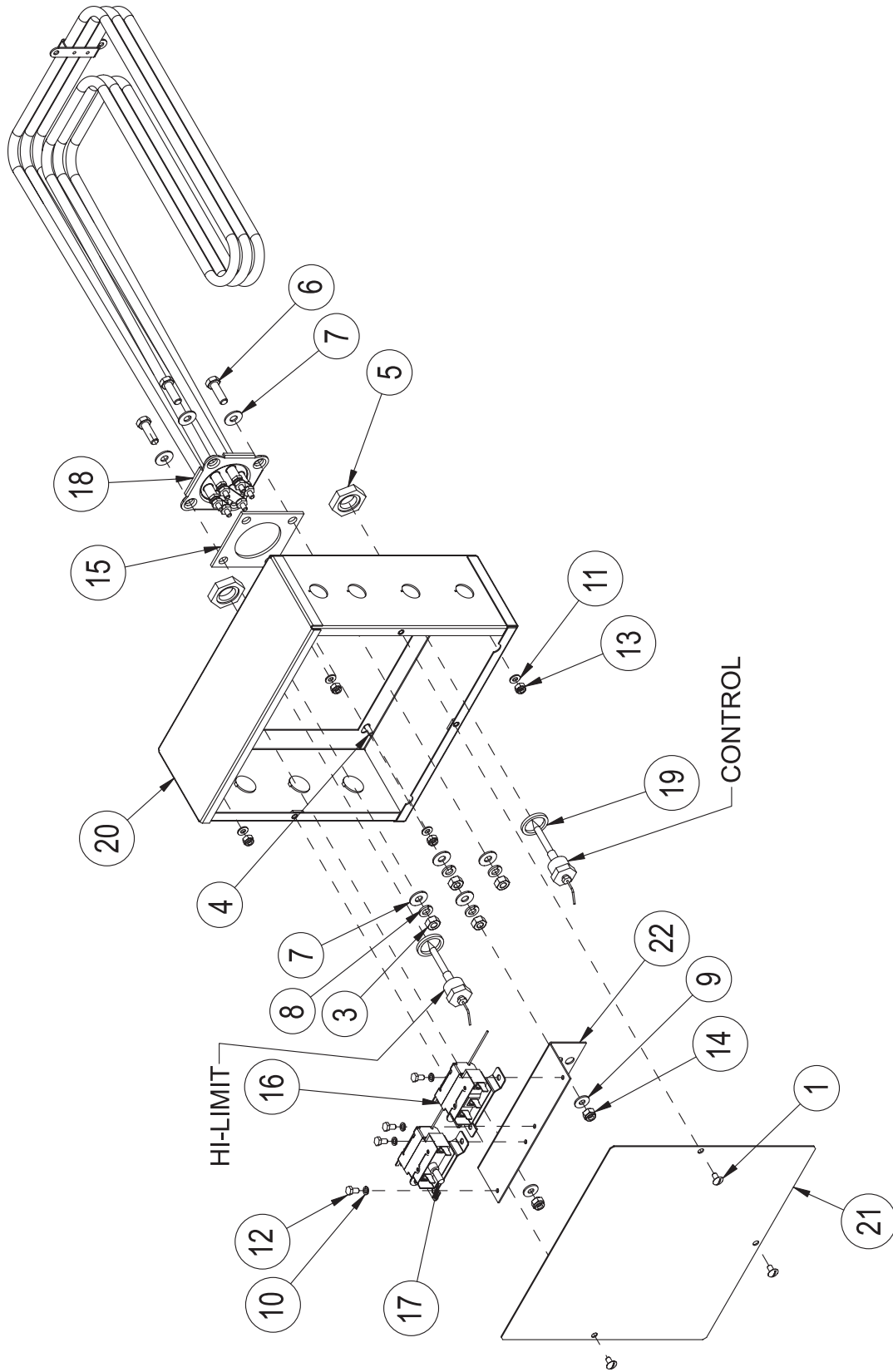

Auxiliary Rinse Electric Tank Heat Installation

Item No.	Part No.	Description	Qty.
1	100007	SCREW,TRUSS HEAD,10-32 x 3/8 SST	3
2	100109	WELD-STUD,1/4-20 X 1/2 LG.SST	2
3	100154	HEX PLAIN NUT,5/16-18 SST	4
4	100198	WELD-STUD,10-32 X 1/2 LG.SST	4
5	100547	LOCKNUT,1/2" NPT,SST	2
6	100740	HEX HEAD,5/16-18 X 1 SST	4
7	102376	WASHER,FLAT,5/16x3/4x.06 SST	8
8	106013	WASHER,LOCK,5/16 SPLIT,SST	4
9	106026	WASHER,FLAT,1/4x5/8x.06 SST	2
10	106486	WASHER,LOCK,#10 SPLIT,SST	4
11	107033	WASHER,FLAT, .208X.438X.047 SST	4
12	107136	SCREW,HEX HEAD,10-32 x 3/8 SST	4
13	107966	HEX GRIP NUT,10-32 SST W/NYLON	4
14	107967	HEX GRIP NUT,1/4-20 SST W/NYLON	2
15	108345	GASKET,HEATER/STANDPIPE	1
16	109069	THERMOSTAT,CONTROL,WITH CAPILLARY	1
17	110561	THERMOSTAT,HI-LIMIT,WITH CAPILLARY	1
18	113804	HEATER,10/12.1 kW, 200-220V	1
	113882	HEATER,10/11 kW, 230/240V	1
	113883	HEATER,10/11 kW, 460/480	1
	113884	HEATER,10/11 kW 575V	1
19	201041	WASHER,SPACER,7/8x1 3/16x1/8 NP	2
20	322811	HEATER BOX WELDMENT,E2-B	1
21	322812	COVER,HEATER BOX,E2-BKT	1
22	323430	BRACKET, THERMOSTATS,USN72,44CR	1

**NOTE:**

The location of a booster heater element is critical for the proper repair of the booster.  
**VERIFY THE LOCATION OF ITEM NO. 3**

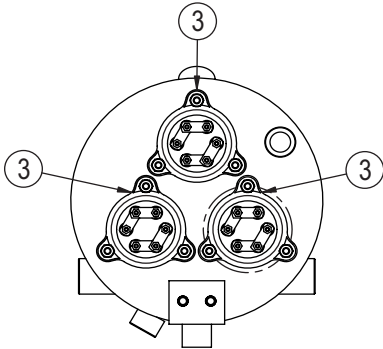

*EUCCW-6 / EUCC-6*  
*EUCCW-4 / EUCC-4*  
 40°F / 22° Rise  
**BOOSTER ASSY,ELEC,R-L,15kW@208V**

Item No.	Part No.	Description	Qty.
1	100003	HEX PLAIN NUT, 1/4-20 SST	9
2	106482	WASHER, LOCK, 1/4 SPLIT SST	9
3	111235	HEATER 5KW_6.5KW, 208-240V, 1PH BOOSTER	3
4	414331	TANK, BOOSTER	1

111384 HEATER 5 KW, 575/60/3

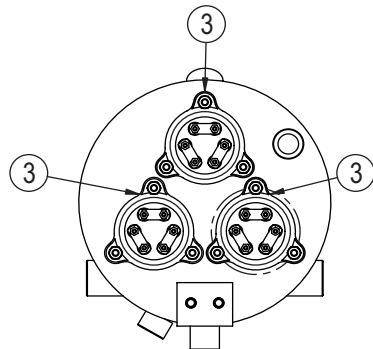

*EUCCW-6 / EUCC-6*  
*EUCCW-4 / EUCC-4*  
 40°F / 22° Rise  
**BOOSTER ASSY,ELEC,R-L,15kW@240V**

Item No.	Part No.	Description	Qty.
1	100003	HEX PLAIN NUT, 1/4-20 SST	9
2	106482	WASHER, LOCK, 1/4 SPLIT SST	9
3	111236	HEATER 5KW, 240V,3PH BOOSTER	3
4	414331	TANK, BOOSTER	1

111384 HEATER 5 KW, 575/60/3

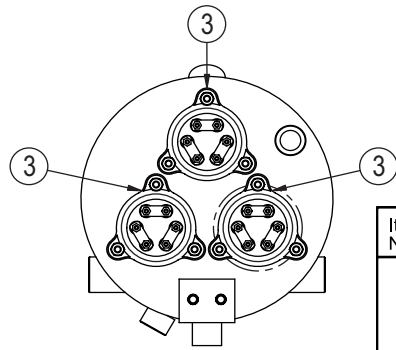

*EUCCW-6 / EUCC-6*  
*EUCCW-4 / EUCC-4*  
 40°F / 22° Rise  
**BOOSTER ASSY,ELEC,R-L,15kW@480V**

Item No.	Part No.	Description	Qty.
1	100003	HEX PLAIN NUT, 1/4-20 SST	9
2	106482	WASHER, LOCK, 1/4 SPLIT SST	9
3	111237	HEATER 5KW, 480V,3PH BOOSTER	3
4	414331	TANK, BOOSTER	1

111384 HEATER 5 KW, 575/60/3

**NOTE:**

The location of a booster heater element is critical for the proper repair of the booster. VERIFY THE LOCATION OF ITEM NO. 3

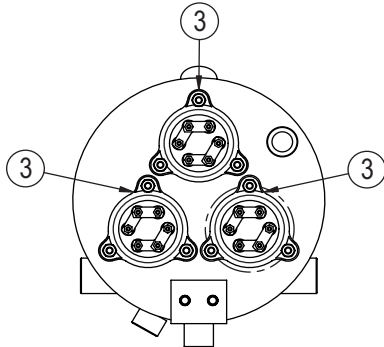

*EUCCW-6 / EUCC-8*  
40°F / 22° Rise

BOOSTER ASSY,ELEC,R-L,18kW@208V

Item No.	Part No.	Description	Qty.
1	100003	HEX PLAIN NUT, 1/4-20 SST	9
2	106482	WASHER, LOCK, 1/4 SPLIT SST	9
3	107909	HEATER 6KW_8KW, 208-240V, 3PH BOOSTER	3
4	414331	TANK, BOOSTER	1

111383 HEATER 10 KW, 575/60/3

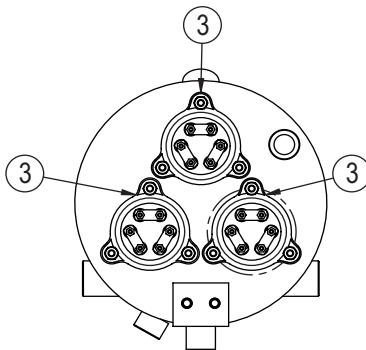

*EUCCW-8 / EUCC-8*  
40°F / 22° Rise

BOOSTER ASSY,ELEC,R-L,18kW@240V

Item No.	Part No.	Description	Qty.
1	100003	HEX PLAIN NUT, 1/4-20 SST	9
2	106482	WASHER, LOCK, 1/4 SPLIT SST	9
3	114030	HEATER 6KW, 240V, 3PH BOOSTER	3
4	414331	TANK, BOOSTER	1

111384 HEATER 5 KW, 575/60/3

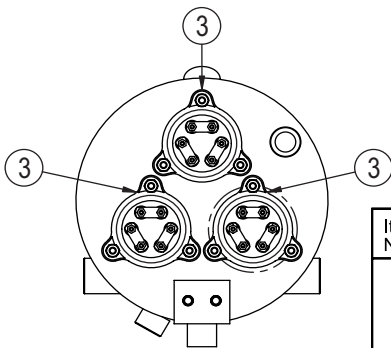

*EUCCW-8 / EUCC-8*  
40°F / 22° Rise

BOOSTER ASSY,ELEC,R-L,18kW@480V

Item No.	Part No.	Description	Qty.
1	100003	HEX PLAIN NUT, 1/4-20 SST	9
2	106482	WASHER, LOCK, 1/4 SPLIT SST	9
3	114031	HEATER 5KW, 480V,3PH BOOSTER	3
4	414331	TANK, BOOSTER	1

111384 HEATER 5 KW, 575/60/3

Electric Booster Element Configuration

**NOTE:**

**The location of a booster heater element is critical for the proper repair of the booster. VERIFY THE LOCATION OF ITEM NO. 3 & 4**

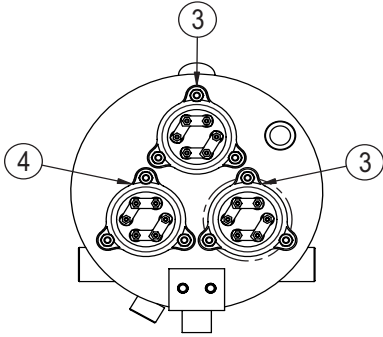

*EUCCW-6 / EUCC-6  
EUCCW-4 / EUCC-4  
70°F / 39° Rise*

BOOSTER ASSY,ELEC,R-L,25kW@208V

Item No.	Part No.	Description	Qty.
1	100003	HEX PLAIN NUT, 1/4-20 SST	9
2	106482	WASHER, LOCK, 1/4 SPLIT SST	9
3	111232	HEATER 10KW 208V,3PH BOOSTER	2
4	111235	HEATER 5KW_6.5KW, 208/240V,3PH BOOSTER	1
5	414331	TANK, BOOSTER	1

111383 HEATER 10 KW, 575/60/3  
111384 HEATER 5 KW, 575/60/3

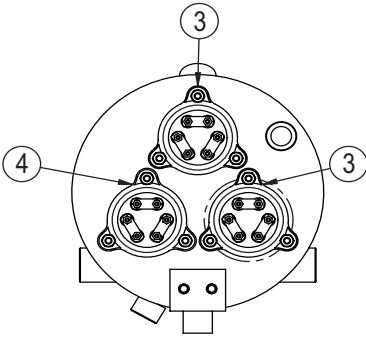

*EUCCW-6 / EUCC-6  
EUCCW-4 / EUCC-4  
70°F / 39° Rise*

BOOSTER ASSY,ELEC,R-L,25kW@240V

Item No.	Part No.	Description	Qty.
1	100003	HEX PLAIN NUT, 1/4-20 SST	9
2	106482	WASHER, LOCK, 1/4 SPLIT SST	9
3	111233	HEATER 7.5KW_10KW 208/240V,3PH BOOSTER	2
4	111236	HEATER 5KW_10KW, 240V,3PH BOOSTER	1
5	414331	TANK, BOOSTER	1

111383 HEATER 10 KW, 575/60/3  
111384 HEATER 5 KW, 575/60/3

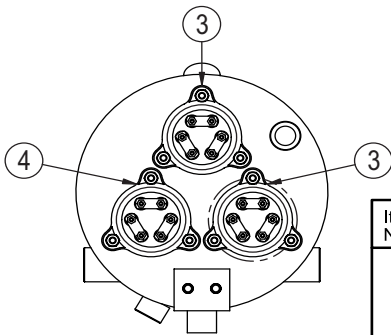

*EUCCW-6 / EUCC-6  
EUCCW-4 / EUCC-4  
70°F / 39° Rise*

BOOSTER ASSY,ELEC,R-L,25kW@480V

Item No.	Part No.	Description	Qty.
1	100003	HEX PLAIN NUT, 1/4-20 SST	9
2	106482	WASHER, LOCK, 1/4 SPLIT SST	9
3	111234	HEATER 10KW, 480V,3PH BOOSTER	2
4	111237	HEATER 5KW, 480V,3PH BOOSTER	1
5	414331	TANK, BOOSTER	1

111383 HEATER 10 KW, 575/60/3  
111384 HEATER 5 KW, 575/60/3



**NOTE:**

**The location of a booster heater element is critical for the proper repair of the booster. VERIFY THE LOCATION OF ITEM NO. 3 & 4**

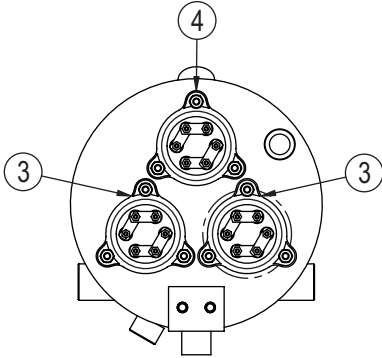

*EUCCW-8 / EUCC-8*

70°F / 39° Rise

BOOSTER ASSY,ELEC,R-L,32kW@208V

Item No.	Part No.	Description	Qty.
1	100003	HEX PLAIN NUT, 1/4-20 SST	9
2	106482	WASHER, LOCK, 1/4 SPLIT SST	9
3	111232	HEATER 10KW 208V,3PH BOOSTER	2
4	112059	HEATER 12KW, 208V,3PH BOOSTER	1
5	414331	TANK, BOOSTER	1

111383 HEATER 10 KW, 575/60/3  
112061 HEATER 12 KW, 575/60/3

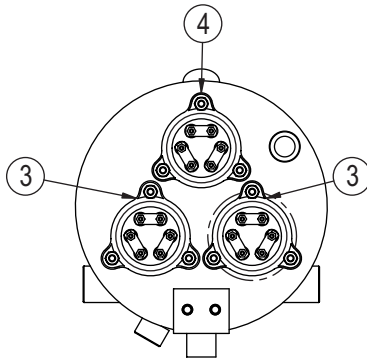

*EUCCW-8 / EUCC-8*

70°F / 39° Rise

BOOSTER ASSY,ELEC,R-L,32kW@240V

Item No.	Part No.	Description	Qty.
1	100003	HEX PLAIN NUT, 1/4-20 SST	9
2	106482	WASHER, LOCK, 1/4 SPLIT SST	9
3	111233	HEATER 7.5KW_10KW 208/240V,3PH BOOSTER	2
4	111334	HEATER 9KW_12KW, 208/240V,3PH BOOSTER	1
5	414331	TANK, BOOSTER	1

111383 HEATER 10 KW, 575/60/3  
112061 HEATER 12 KW, 575/60/3

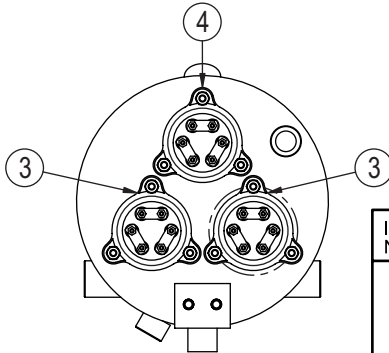

*EUCCW-8 / EUCC-8*

70°F / 39° Rise

BOOSTER ASSY,ELEC,R-L,32kW@480V

Item No.	Part No.	Description	Qty.
1	100003	HEX PLAIN NUT, 1/4-20 SST	9
2	106482	WASHER, LOCK, 1/4 SPLIT SST	9
3	111234	HEATER 10KW, 480V,3PH BOOSTER	2
4	112060	HEATER 12KW, 480V,3PH BOOSTER	1
5	414331	TANK, BOOSTER	1

**NOTE:**

The location of a booster heater element is critical for the proper repair of the booster.  
**VERIFY THE LOCATION OF ITEM NO. 3 & 4**

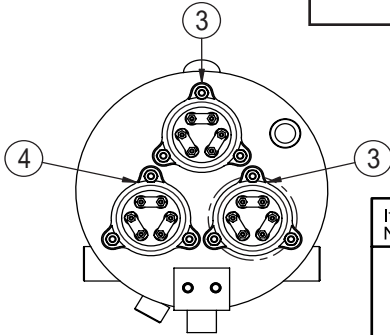

*EUCC-4 / EUCC-3*  
 40°F / 22° Rise

**BOOSTER ASSY,ELEC,R-L,16kW@208V**

Item No.	Part No.	Description	Qty.
1	100003	HEX PLAIN NUT, 1/4-20 SST	9
2	106482	WASHER, LOCK, 1/4 SPLIT SST	9
3	107909	HEATER 6KW/8KW, 208/240V,3PH BOOSTER	1
4	111235	HEATER 5KW/6.6KW, 208/240V,3PH BOOSTER	2
5	414331	TANK, BOOSTER	1

111383 HEATER 5KW, 575/60/3  
 114032 HEATER 6KW, 575/60/3

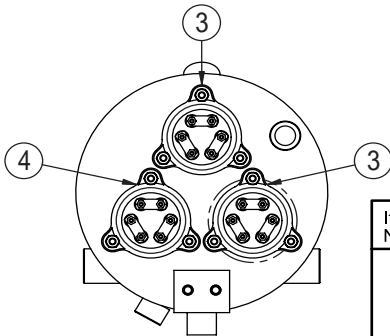

*EUCC-4 / EUCC-3*  
 40°F / 22° Rise

**BOOSTER ASSY,ELEC,R-L,16kW@240V**

Item No.	Part No.	Description	Qty.
1	100003	HEX PLAIN NUT, 1/4-20 SST	9
2	106482	WASHER, LOCK, 1/4 SPLIT SST	9
3	114030	HEATER 6KW, 240V,3PH BOOSTER	1
4	111236	HEATER 5KW, 240V,3PH BOOSTER	2
5	414331	TANK, BOOSTER	1

111383 HEATER 5KW, 575/60/3  
 114032 HEATER 6KW, 575/60/3

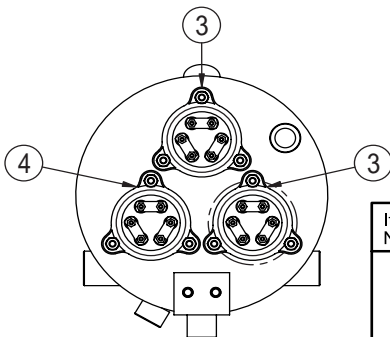

*EUCC-4 / EUCC-3*  
 40°F / 22° Rise

**BOOSTER ASSY,ELEC,R-L,16kW@480V**

Item No.	Part No.	Description	Qty.
1	100003	HEX PLAIN NUT, 1/4-20 SST	9
2	106482	WASHER, LOCK, 1/4 SPLIT SST	9
3	114031	HEATER 6KW, 480V,3PH BOOSTER	1
4	111237	HEATER 5KW, 480V,3PH BOOSTER	2
5	414331	TANK, BOOSTER	1

111383 HEATER 5KW, 575/60/3  
 114032 HEATER 6KW, 575/60/3

**NOTE:**

The location of a booster heater element is critical for the proper repair of the booster.  
**VERIFY THE LOCATION OF ITEM NO. 3 & 4**

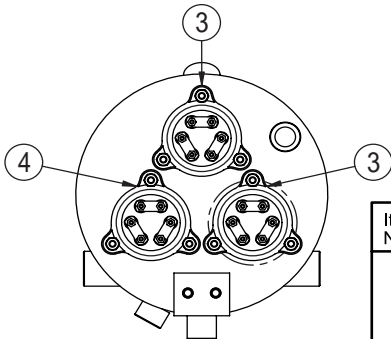

*EUCC-4 / EUCC-3*  
 70°F / 39° Rise

**BOOSTER ASSY,ELEC,R-L,28kW@208V**

Item No.	Part No.	Description	Qty.
1	100003	HEX PLAIN NUT, 1/4-20 SST	9
2	106482	WASHER, LOCK, 1/4 SPLIT SST	9
3	111334	HEATER 9KW/12KW, 208/240V,3PH BOOSTER	2
4	111232	HEATER 10KW, 208V,3PH BOOSTER	1
5	414331	TANK, BOOSTER	1

111383 HEATER 10 KW, 575/60/3  
 112061 HEATER 12 KW, 575/60/3

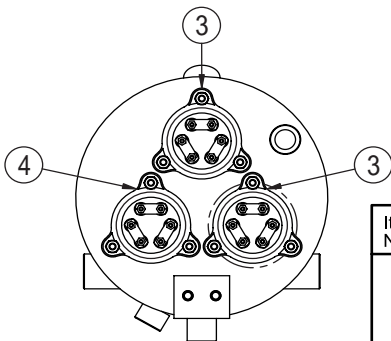

*EUCC-4 / EUCC-3*  
 70°F / 39° Rise

**BOOSTER ASSY,ELEC,R-L,28kW@240V**

Item No.	Part No.	Description	Qty.
1	100003	HEX PLAIN NUT, 1/4-20 SST	9
2	106482	WASHER, LOCK, 1/4 SPLIT SST	9
3	111305	HEATER 9KW, 240V,3PH BOOSTER	2
4	111233	HEATER 7.5KW/10KW, 208V-240V,3PH BOOSTER	1
5	414331	TANK, BOOSTER	1

111383 HEATER 10 KW, 575/60/3  
 112061 HEATER 12 KW, 575/60/3

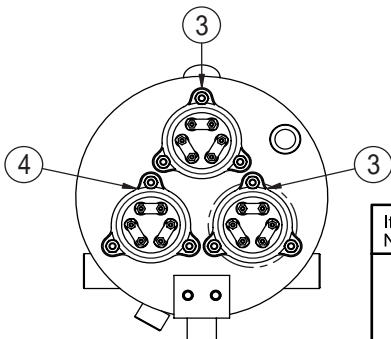

*EUCC-4 / EUCC-3*  
 70°F / 39° Rise

**BOOSTER ASSY,ELEC,R-L,28kW@480V**

Item No.	Part No.	Description	Qty.
1	100003	HEX PLAIN NUT, 1/4-20 SST	9
2	106482	WASHER, LOCK, 1/4 SPLIT SST	9
3	108579	HEATER 9KW, 480V,3PH BOOSTER	2
4	111234	HEATER 10KW, 480V,3PH BOOSTER	1
5	414331	TANK, BOOSTER	1

111383 HEATER 10 KW, 575/60/3  
 112061 HEATER 12 KW, 575/60/3

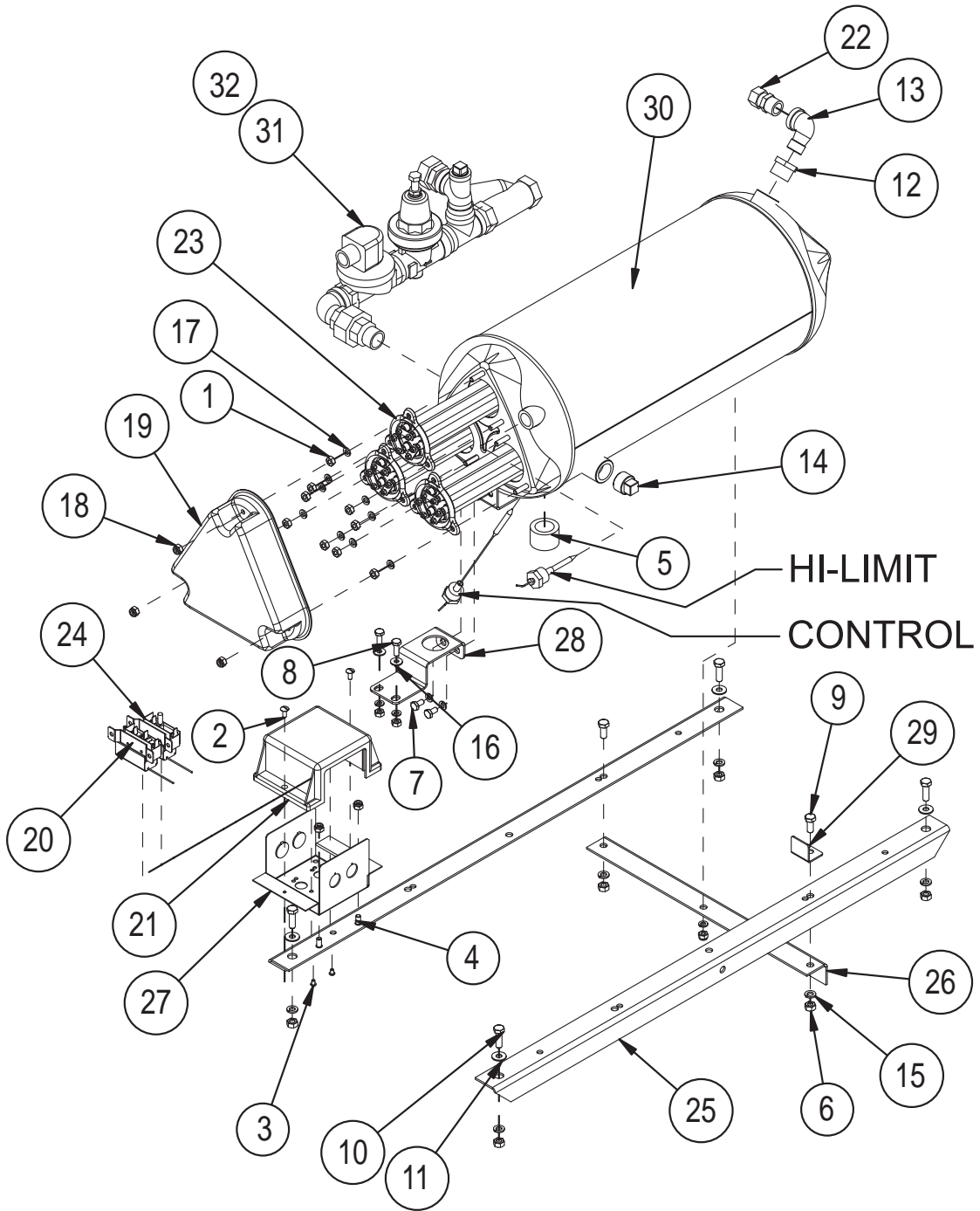

Item No.	Part No.	Description	Qty.
1	100003	HEX PLAIN NUT,1/4-20 SST	11
2	100097	SCREW,TRUSS HEAD,10-32 x 1/2 SST	2
3	100100	SCREW,ROUND HEAD,8-32 x 1/4 SST	2
4	100109	WELD-STUD,1/4-20 X 1/2 LG.SST	2
5	100113	CAP,3/4" NPT SST	1
6	100154	HEX PLAIN NUT,5/16-18 SST	6
7	100734	HEX HEAD,1/4-20 X 1/2 SST	2
8	100736	HEX HEAD,1/4-20 X 3/4 SST	2
9	100739	HEX HEAD,5/16-18 X 3/4 SST	2
10	100740	HEX HEAD,5/16-18 X 1 SST	4
11	102376	WASHER,FLAT,5/16x3/4x.06 SST	4
12	102392	BUSHING,REDUCING,3/4"NPTx1/2"NPT,BRASS	1
13	102438	ELBOW,STREET,1/2"NPT X 90, BRASS	1
14	102505	PLUG,3/4"NPT SQ.HEAD,BRASS	1
15	106013	WASHER,LOCK,5/16 SPLIT,SST	6
16	106026	WASHER,FLAT,1/4x5/8x.06 SST	2
17	106482	WASHER,LOCK,1/4 SPLIT,SST	14
18	107967	HEX GRIP NUT,1/4-20 SST W/NYLON	6
19	108576	BOOSTER HEATER COVER	1
20	109069	THERMOSTAT WITH CAPILLARY	1
21	109682	THERMOSTAT COVER BOX	1
22	109925	FITTING, COMP 5/8 OD X 1/2 MPT BRASS	1
23	109985	O-RING,BOOSTER HEATER	3
24	110561	THERMOSTAT WITH CAPILLARY	1
25	206668	ANGLE,ELECTRIC BOOSTER SUPPORT EUCCW	2
---	206689	ANGLE,ELECTRIC BOOSTER SUPPORT EUCC	2
26	206669	ANGLE,ELECTRIC BOOSTER SUPPORT	1
27	314102	BOX,DUAL THERMOSTAT	1
28	328254	BRACKET,BOOSTER SUPPORT,W/HOLE	1
29	330571	BRACKET,PIPING SUPPORT,ELECTRIC BOOSTER	1
30	414331	TANK. BOOSTER WELDMENT	1
31	601833	SEE PAGE 102-103 FOR PIPING ASSY BREAKDOWN	1
32	601931	SEE PAGE 104-105 FOR PIPING ASSY BREAKDOWN	1

# Float Switches

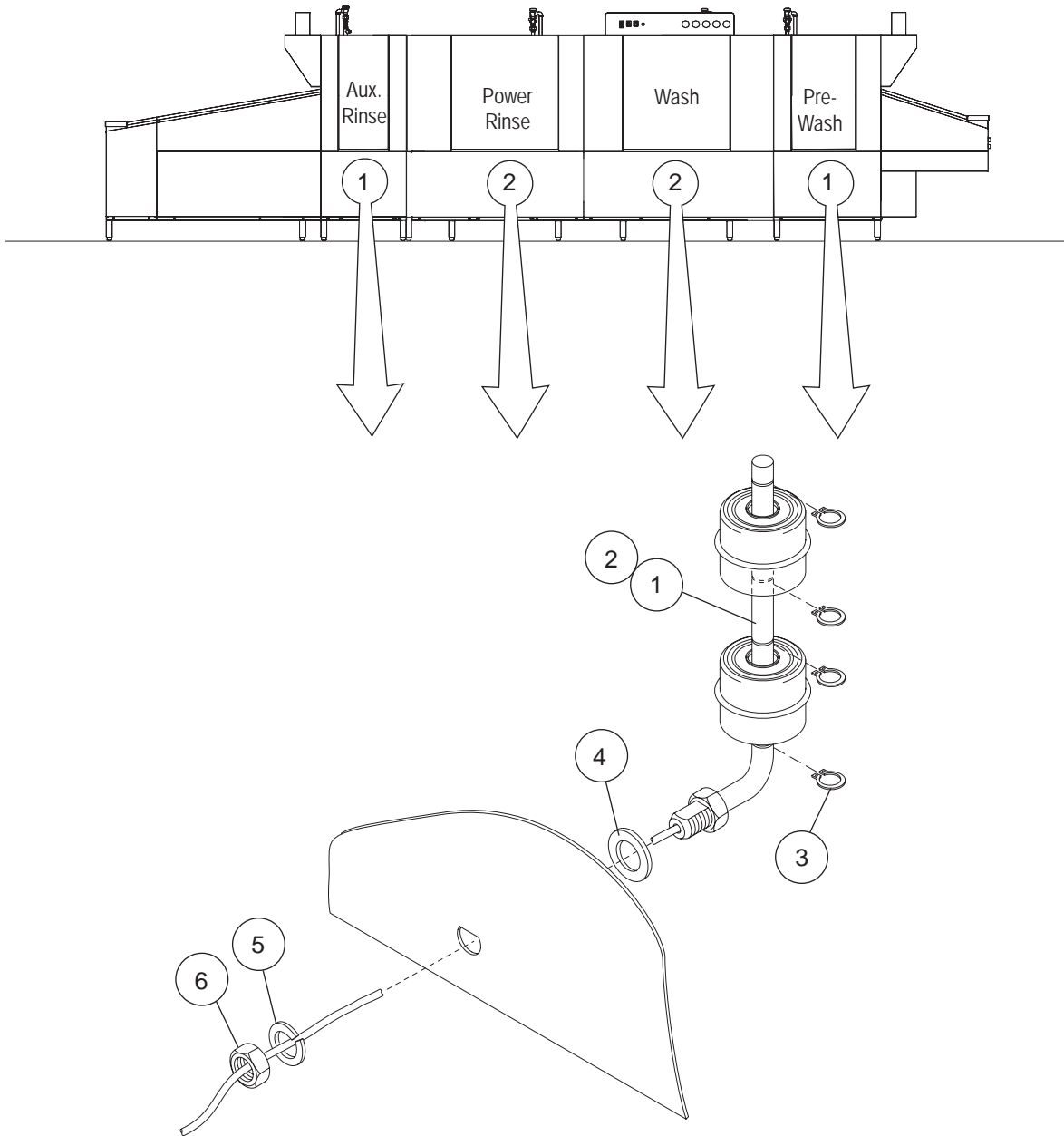

Item No.	Part No.	Description	Qty.
1	111019	FLOAT SWITCH, DUAL (Auxiliary Rinse, Prewash Tank)	1
2	113291	FLOAT SWITCH, DUAL (Wash, Power Rinse Tank)	1
3	111151	C-Clip (4 per float switch)	A/R
4	104882	WASHER, FLAT .531" X .062" X .062"	1
5	107589	WASHER, LOCK 1/2" SPLIT	1
6	104584	NUT, PLAIN 1/2-13 HEX SST	1

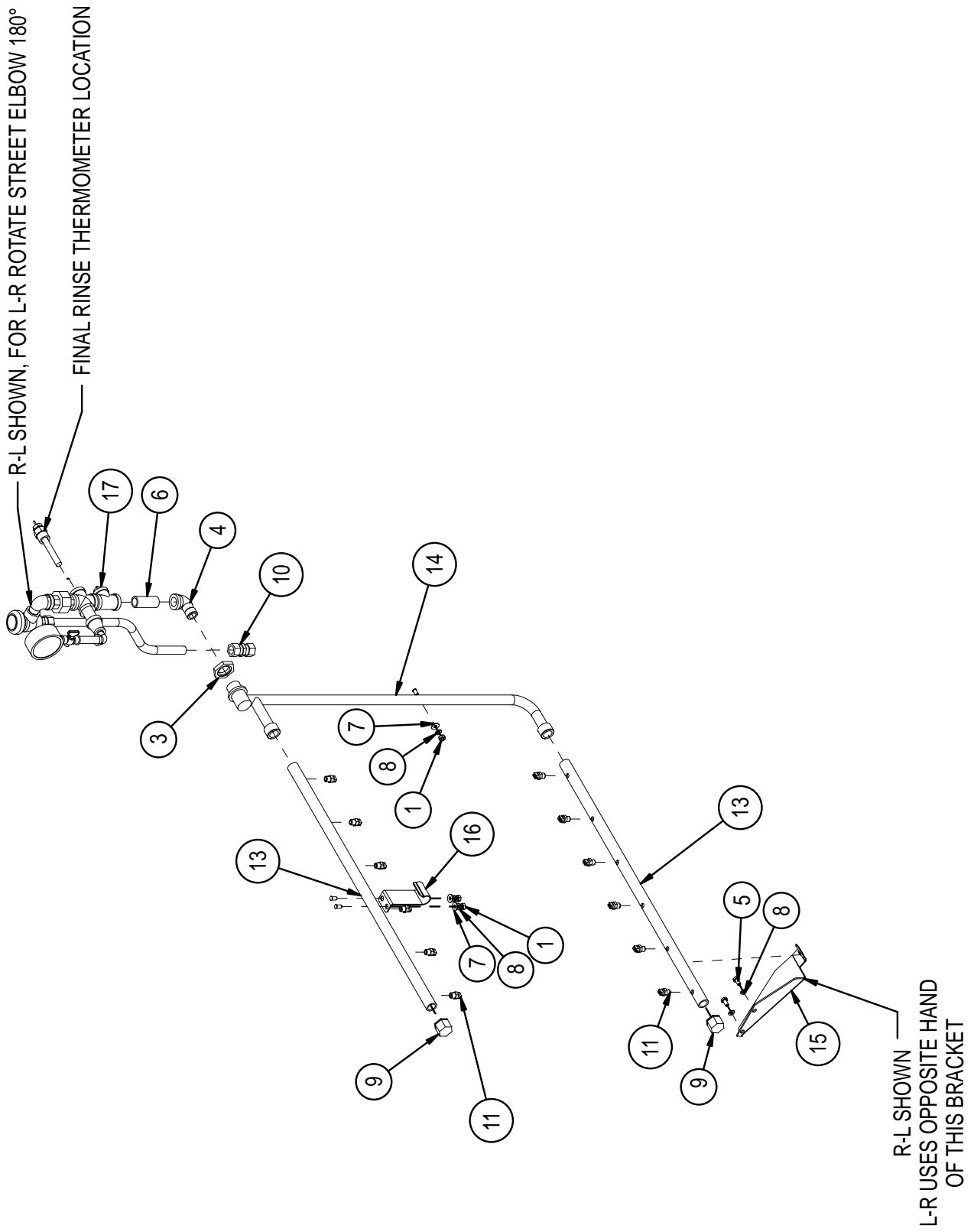



Item No.	Part No.	Description	Qty.
1	100003	HEX PLAIN NUT,1/4-20 SST	3
2	100109	WELD-STUD,1/4-20 X 1/2 LG.SST	3
3	100156	LOCKNUT,3/4" NPT,BRASS	1
4	100516	STREET ELBOW,1/2"NPT X 90,SST	1
5	100734	CAP SCREW,HEX HEAD,1/4-20 X 1/2 SST	2
6	102461	NIPPLE,1/2"NPT X 2"LG.,SST	1
7	106026	WASHER,FLAT,1/4x5/8x.06 SST	3
8	106482	WASHER,LOCK,1/4 SPLIT,SST	5
9	106734	CAP,RINSE PIPE,1/2NPT PLASTIC	2
10	109924	FITTING, COMP 5/8 OD UNION BRASS	1
11	111203	NOZZLE,VEE-JET,#8003, SPRAY FAN @20PSI EUCCW	12
--	111203	NOZZLE,VEE-JET,#8003, SPRAY FAN @20PSI EUCC	10
12	114183	PROBE ASSY,16' THERMOMETER	1
13	206580	PIPE,FINAL RINSE,UPPER/LOWER EUCCW	2
--	206707	PIPE,FINAL RINSE,UPPER/LOWER EUCC	2
14	329800	MANIFOLD WELDMENT,E2 FRESH	1
15	330551-2	BRACKET,LOWER PIPE SUPPORT,E2	1
16	330553	BRACKET,FINAL RINSE,UPPER,PIPE	1
17	601822	PIPING SUB-ASSY,FINAL RINSE	1
---	100209	NIPPLE CLOSE, 1/2NPT BRASS	2
---	100135	PRESSURE GAUGE, 0-60 PSI	1
---	100500	VACUUM BREAKER, 1/2NPT, BRASS	1
	108439	KIT, REPAIR VACUUM BREAKER	---
---	100554	TEE. 1/2NPT, SST	
---	100598	CROSS, 1/2NPT BRASS	1
---	101261	ELBOW, STREET, 1/4 X 90 BRASS	1
---	102438	ELBOW, STREET, 1/2 X 90 BRASS	1
---	102459	NIPPLE, CLOSE 1/2NPT,SST	1
---	206655	TUBE, FINAL RINSE	1
---	102492	NIPPLE, 1/2 X 2 BRASS	1
---	102504 *	PLUG, 1/2NPT BRASS, SQUARE HD. (Before 11/18/09)	1
---	102549	UNION, 1/2NPT BRASS	1
---	106418	COCK, 1/2 AIR FEMALE	1
---	109925	FITT, COMP, 5/8OD X 1/2MPT	1
---	110134	NIPPLE, 1/4 X 2-1/2 BRASS	1
---	114182	COUPLING, REDUCER, 1/2 X 1/4 BRASS	1
----	101529*	PLUG 1/8" BRASS SQUARE HD. (Beginning 11/18/09)	1
----	114717*	BUSHING, RED. 1/2" X 1/8" SST (Beginning 11/18/09)	1

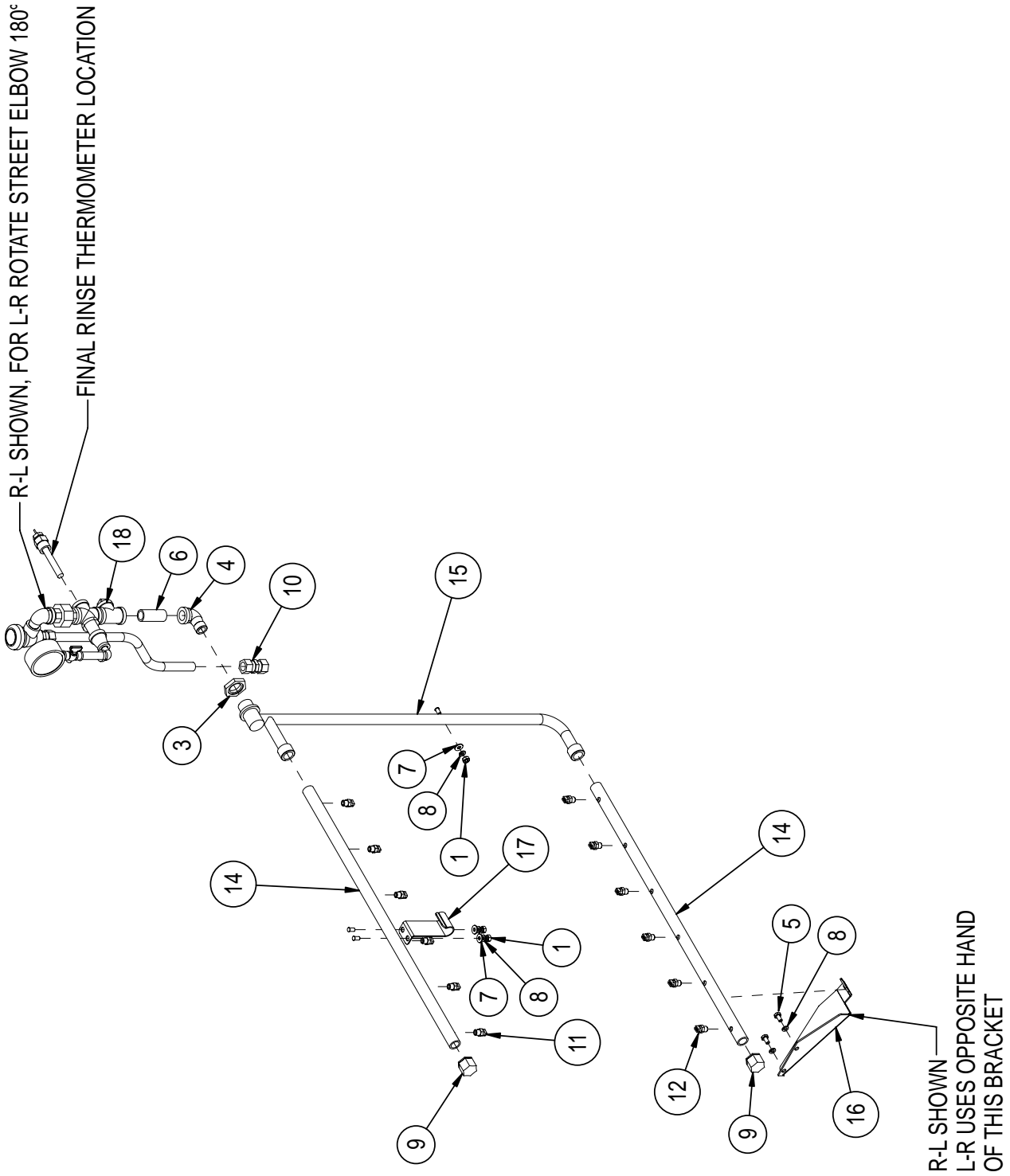

Item No.	Part No.	Description	Qty.
1	100003	HEX PLAIN NUT,1/4-20 SST	3
2	100109	WELD-STUD,1/4-20 X 1/2 LG.SST	3
3	100156	LOCKNUT,3/4" NPT,BRASS	1
4	100516	STREET ELBOW,1/2"NPT X 90,SST	1
5	100734	HEX HEAD,1/4-20 X 1/2 SST	2
6	102461	NIPPLE,1/2"NPT X 2"LG.,SST	1
7	106026	WASHER,FLAT,1/4 x 5/8 x .06 SST	3
8	106482	WASHER,LOCK,1/4 SPLIT,SST	5
9	106734	CAP,RINSE PIPE,1/2NPT PLASTIC	2
10	109924	FITTING, COMP 5/8 OD UNION BRASS	1
11	111203	NOZZLE,VEE-JET,#8003, SPRAY FAN @20PSI EUCCW	6
---	111203	NOZZLE,VEE-JET,#8003, SPRAY FAN @20PSI EUCC	5
12	114181	NOZZLE,VEE-JET,#8002, SPRAY FAN @20PSI EUCCW	6
---	114181	NOZZLE,VEE-JET,#8002, SPRAY FAN @20PSI EUCC	5
13	114183	PROBE ASSY,16' THERMOMETER	1
14	206580	PIPE,FINAL RINSE,UPPER/LOWER EUCCW	2
---	206580	PIPE,FINAL RINSE,UPPER/LOWER EUCC	2
15	329800	MANIFOLD WELDMENT,E2 FRESH	1
16	330551-2	BRACKET,LOWER PIPE SUPPORT,E2	1
17	330553	BRACKET,FINAL RINSE,UPPER,PIPE	1
18	601822	PIPING SUB-ASSY,FINAL RINSE	1
----	100209	NIPPLE CLOSE, 1/2NPT BRASS	2
----	100135	PRESSURE GAUGE, 0-60 PSI	1
----	100500	VACUUM BREAKER, 1/2NPT, BRASS	1
	108439	KIT, REPAIR VACUUM BREAKER	---
----	100554	TEE. 1/2NPT, SST	
----	100598	CROSS, 1/2NPT BRASS	1
----	101261	ELBOW, STREET, 1/4 X 90 BRASS	1
----	102438	ELBOW, STREET, 1/2 X 90 BRASS	1
----	102459	NIPPLE, CLOSE 1/2NPT,SST	1
----	206655	TUBE, FINAL RINSE	1
----	102492	NIPPLE, 1/2 X 2 BRASS	1
----	102504*	PLUG, 1/2NPT BRASS, SQUARE HD. (Before 11/18/09)	1
----	102549	UNION, 1/2NPT BRASS	1
----	106418	COCK, 1/2 AIR FEMALE	1
----	109925	FITT, COMP, 5/8OD X 1/2MPT	1
----	110134	NIPPLE, 1/4 X 2-1/2 BRASS	1
----	114182	COUPLING, REDUCER, 1/2 X 1/4 BRASS	1
----	101529*	PLUG 1/8" BRASS SQUARE HD. (Beginning 11/18/09)	1
----	114717*	BUSHING, RED. 1/2" X 1/8" SST (Beginning 11/18/09)	1

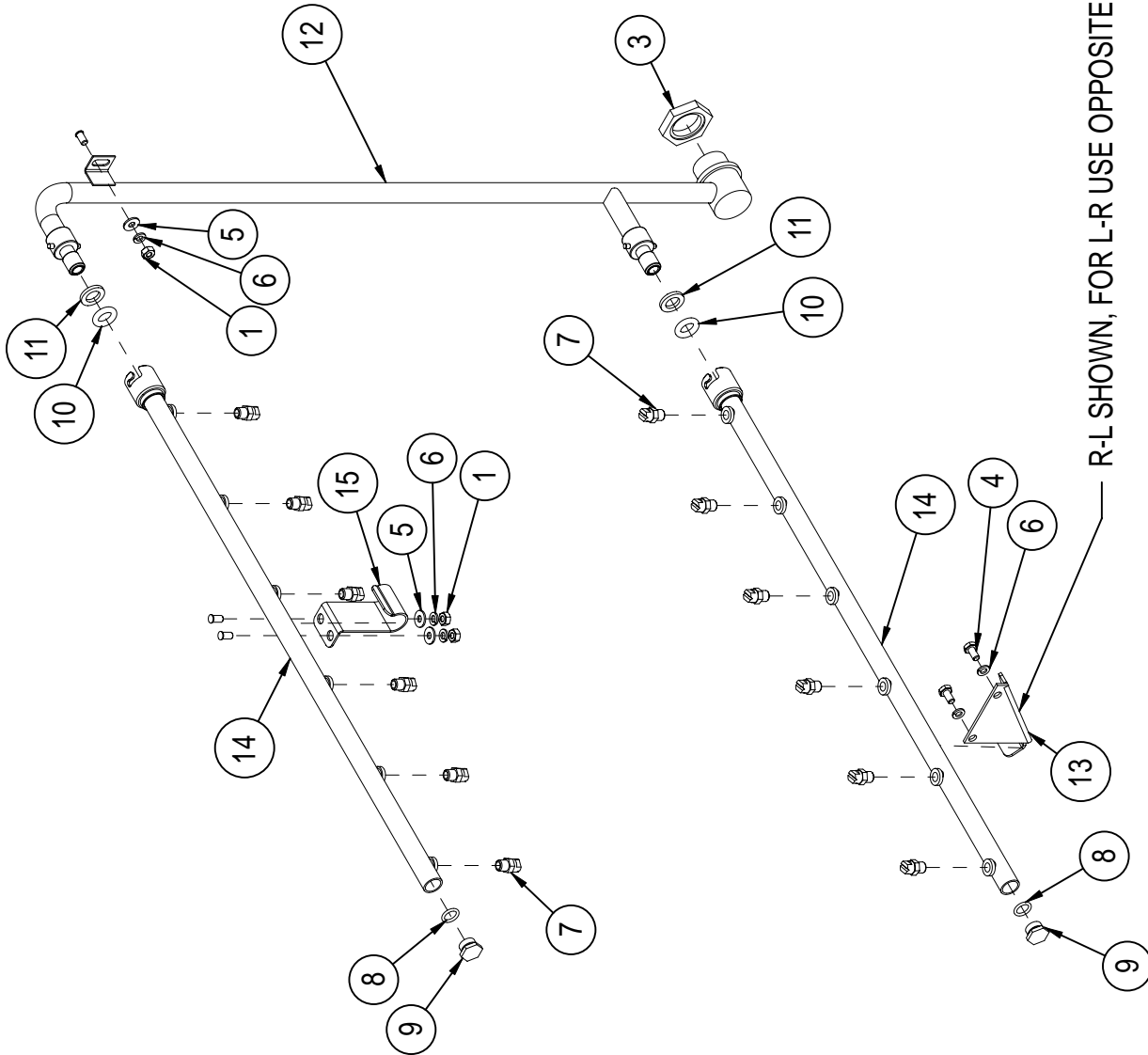

Item No.	Part No.	Description	Qty.
1	100003	HEX PLAIN NUT,1/4-20 SST	3
2	100109	WELD-STUD,1/4-20 X 1/2 LG.SST	3
3	100585	LOCKNUT,1" NPT,BRASS	1
4	100734	HEX HEAD,1/4-20 X 1/2 SST	2
5	106026	WASHER,FLAT,1/4x5/8x.06 SST	3
6	106482	WASHER,LOCK,1/4 SPLIT,SST	5
7	106530	NOZZLE,VEE-JET,#8020, SPRAY FAN @20 PSI EUCCW	12
---	106530	NOZZLE,VEE-JET,#8020, SPRAY FAN @20 PSI EUCC	10
8	113716	WASH-ARMS ORING	2
9	113795	PLUG, E FINAL RINSE MANIFOLD	2
10	114290	O-RING AS568A-311 SILICONE 9/16x15/16x3/16	2
11	114291	WASHER RUBBER 9/16x15/16x1/8 SILICONE	2
12	329799	MANIFOLD WELDMENT,E2 RECIRC	1
13	329802-1	BRACKET,LOWER PIPE SUPPORT,E2	1
14	329803	RINSE PIPE WELDMENT,E2 RECIRC EUCCW	2
---	330737	RINSE PIPE WELDMENT,E2 RECIRC EUCC	2
15	331018	BRACKET, AUX RINSE,UPPER,PIPE	1

***This Page  
Intentionally  
Left Blank***

***This Page  
Intentionally  
Left Blank***

Cold Water Fill Piping Sub-assembly

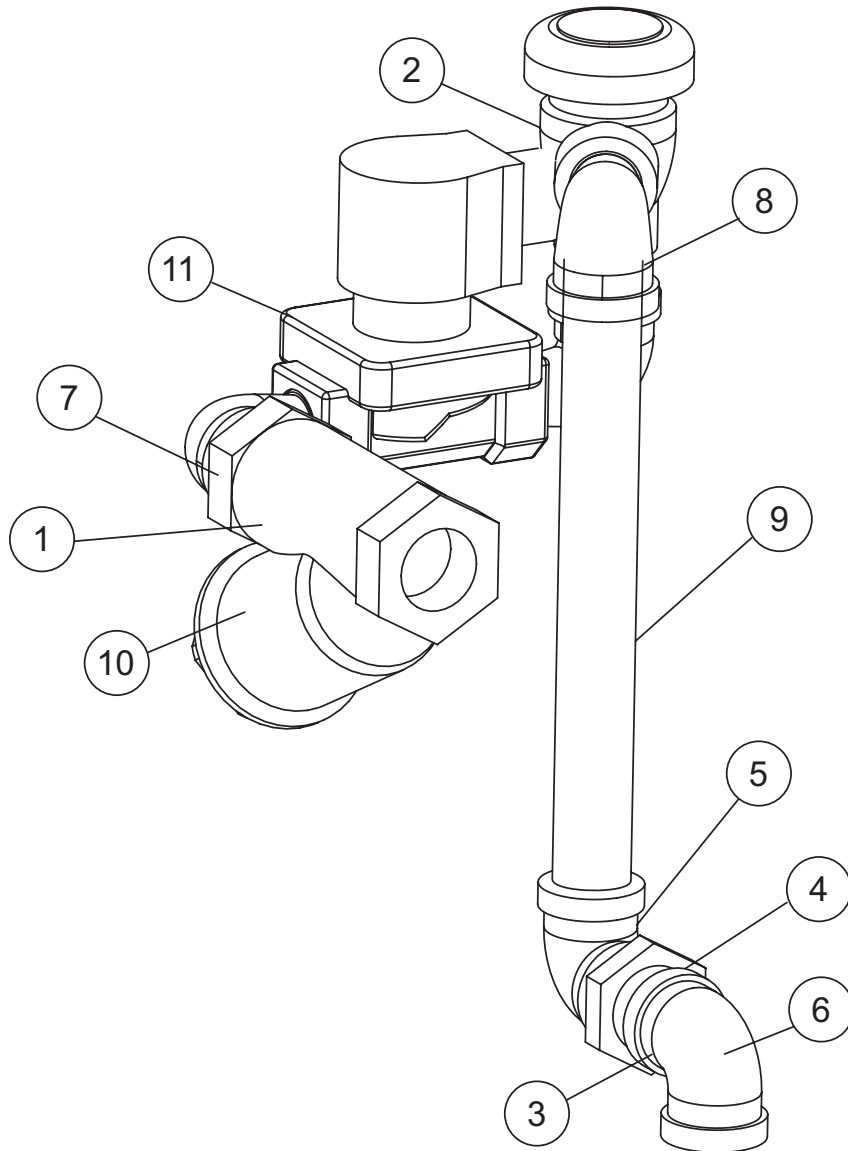



Item No.	Part No.	Description	Qty.
1	100209	NIPPLE,1/2"NPT X CLOSE,BRASS	1
2	100500 108349	VACUUM BREAKER,1/2" NPT BRONZE REPAIR KIT	1
3	100704	NIPPLE,RTOE,1/2"NPT X 1 3/4"LG.,SST	1
4	100709	LOCKNUT,1/2" NPT,BRASS	1
5	102435	ELBOW, 1/2"NPT x 90 DEG,BRASS	1
6	102436	ELBOW,1/2"NPT X 90, SST	1
7	102438	ELBOW,STREET,1/2"NPT X 90, BRASS	3
8	102485	NIPPLE,1/2"NPT X 1 1/2"LG.,BRASS	1
9	102582	NIPPLE,1/2"NPT X 7 1/2"LG.,BRASS	1
10	110768	STRAINER,LINE,3/4"NPT BRONZE FEMALE	1
1	113352	VALVE 1/2" NPT SOLENOID 115V	1
---	113392	REPAIR KIT, 1/2" SOLENOID VALVE	A/R
---	113357	COIL SOLENOID, 1/2" 115VAC	A/R
---	109069	THERMOSTAT, CONTROL	1

Electric Booster Fill Piping (Prior to S/N J10012728)

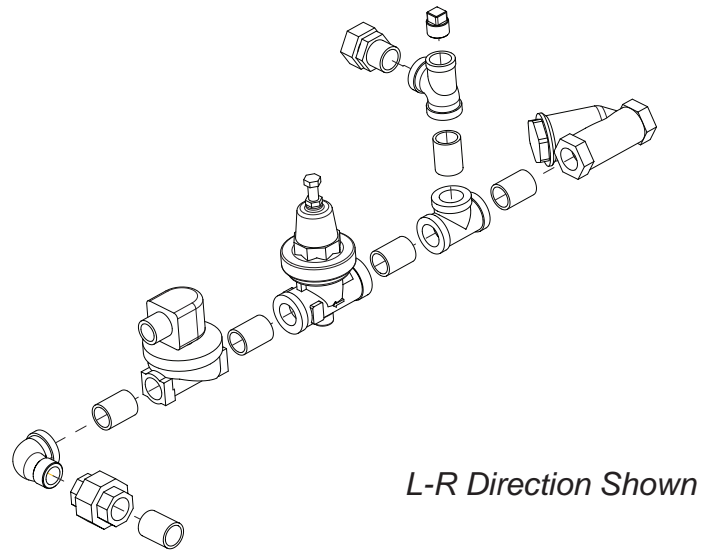
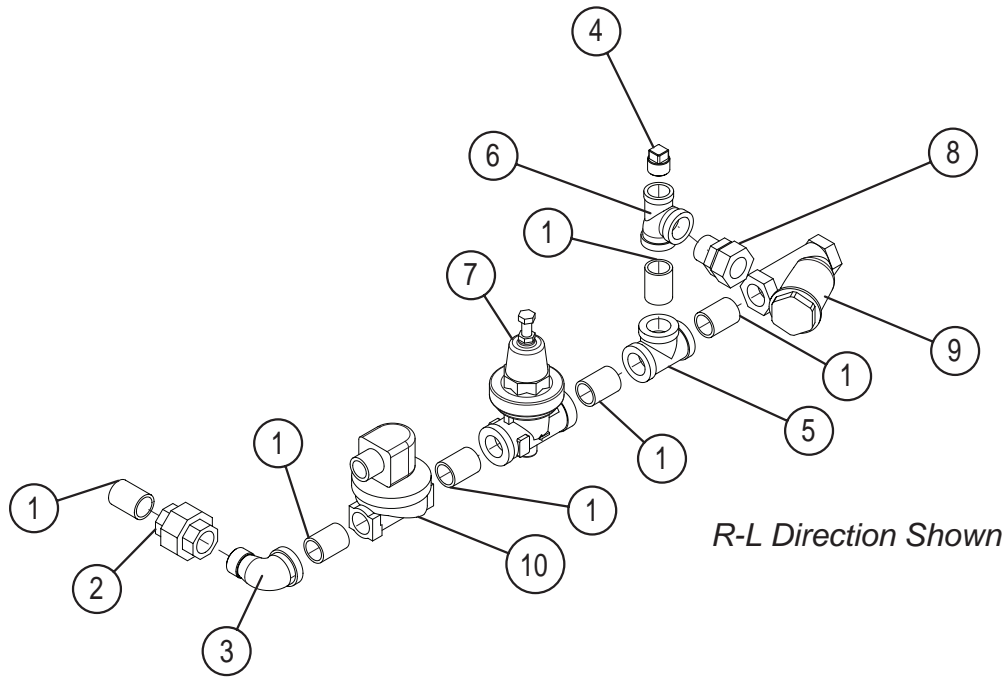

Item No.	Part No.	Description	Qty.
1	100184	NIPPLE,3/4"NPT X CLOSE,BRASS	6
2	100571	UNION,3/4"NPT,BRASS	1
3	102444	ELBOW,STREET,3/4"NPT X 90, BRASS	1
4	102504*	PLUG,1/2"NPT SQ.HEAD,BRASS (Before 11/18/09)	1
5	102521	TEE, 3/4"NPT, BRASS	1
6	102525	TEE,RED,3/4"x1/2"x3/4"NPT, BRASS	1
7	107550	VALVE,PRESSURE REGULATING,3/4"NPT BRONZE	1
8	109879	FITTING, COMP 7/8 OD X 3/4 MPT BRASS	1
9	110768	STRAINER,LINE,3/4"NPT BRONZE FEMALE	1
10	111437	VALVE, SOLENOID 3/4" NPT, HW	1
----	114839	KIT, REPAIR 3/4" SOLENOID VALVE	A/R
----	111472	COIL, 3/4" SOLENOID VALVE 115VAC	A/R
----	101529*	PLUG 1/8" BRASS SQUARE HD. (Beginning 11/18/09)	1
----	114717*	BUSHING, RED. 1/2" X 1/8" SST (Beginning 11/18/09)	1

Electric Booster Fill Piping (Beginning with S/N J10012728 and above)

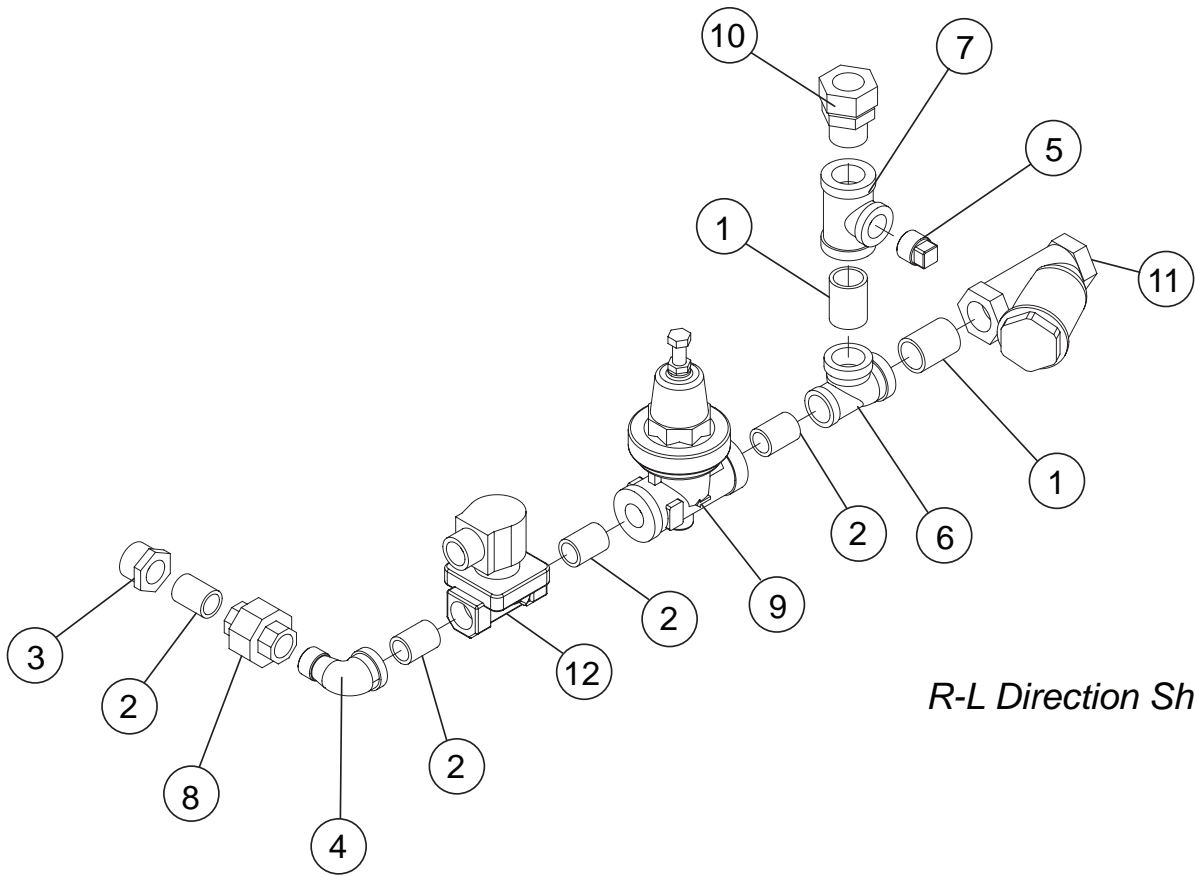

*R-L Direction Shown*

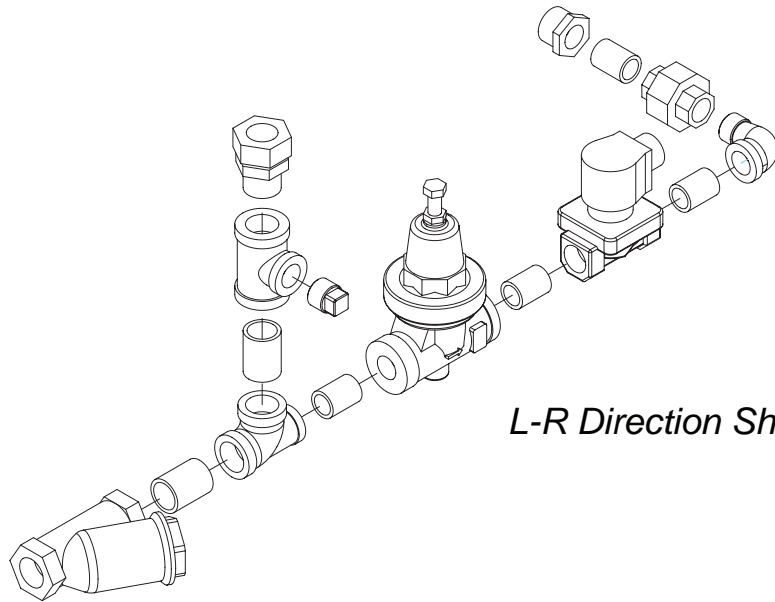

*L-R Direction Shown*

*Electric Booster Fill Piping (Beginning with S/N J10012728 and above)*

Item No.	Part No.	Description	Qty.
1	100184	NIPPLE, 3/4" NPT X CLOSE BRASS	2
2	100209	NIPPLE, 1/2" NPT X CLOSE BRASS	4
3	102392	BUSHING, REDUCING, 3/4" NPT X 1/2" NPT BRASS	1
4	102438	ELBOW, STREET 1/2" X 90° BRASS	1
5	102504	PLUG, 1/2" NPT SQ. HEAD, BRASS	1
6	102525	TEE, RED, 3/4" X 1/2" X 3/4" NPT BRASS	1
7	102526	TEE, RED, 3/4" X 3/4" X 1/2" NPT BRASS	1
8	102549	UNION, 1/2" NPT BRASS	1
9	108265	VALVE, PRESSURE REGULATING, 1/2" NPT BRONZE	1
10	109879	FITTING, COMP. 7/8" OD X 3/4" MPT BRASS	1
11	110768	STRAINER, LINE 3/4" NPT BRONZE FEMALE	1
12	113352	VALVE, 1/2" NPT SOLENOID 115VAC	1
---	113392	KIT, REPAIR 1/2" SOLENOID VALVE	A/R
---	113357	COIL, SOLENOID 1/2" VALVE 115VAC	A/R

Fill Piping - No Booster (Prior to S/N J10012728)

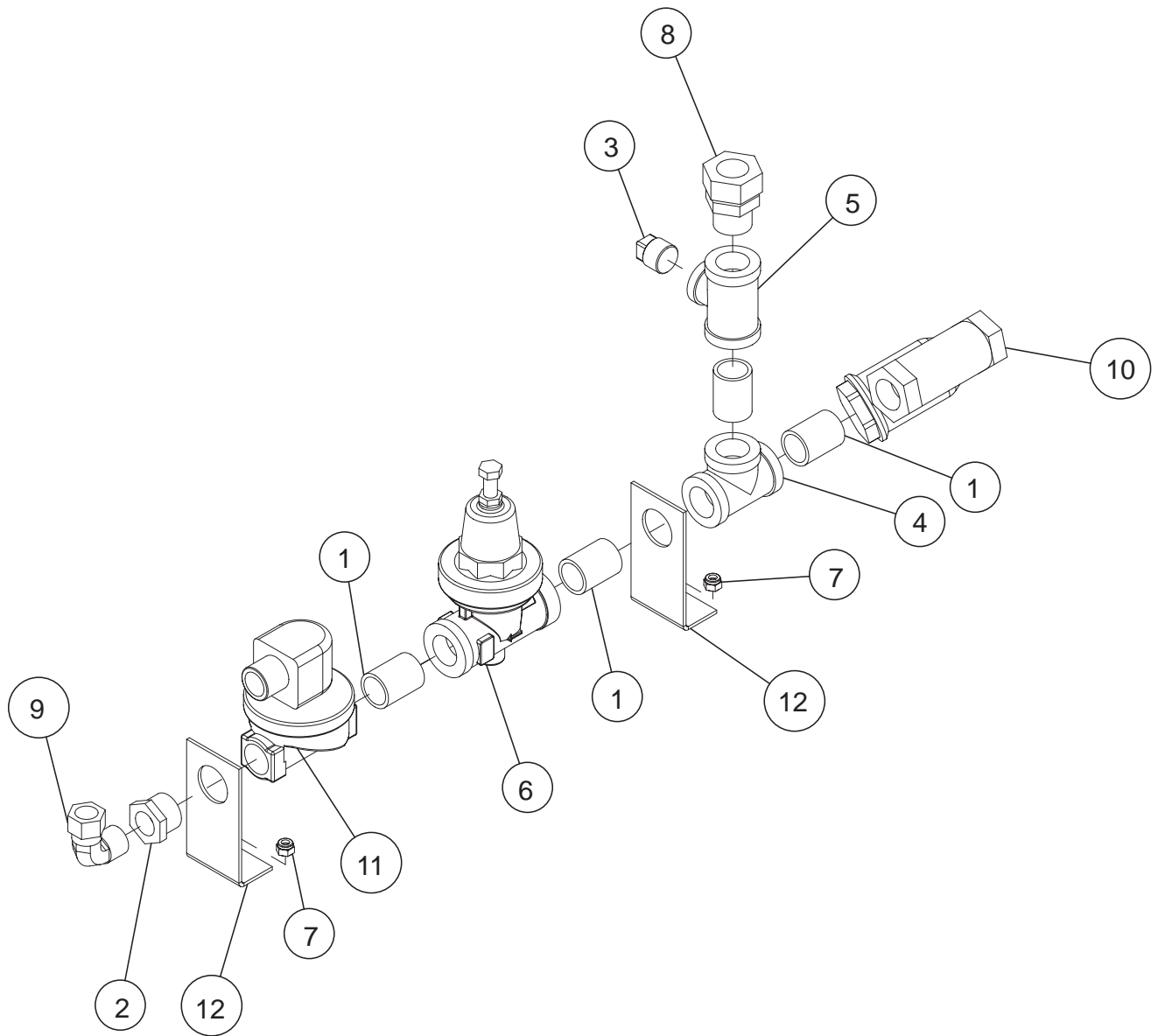

Item No.	Part No.	Description	Qty.
1	100184	NIPPLE, 3/4" NPT X CLOSE BRASS	4
2	102392	BUSHING, REDUCING, 3/4" NPT X 1/2" NPT BRASS	1
3	102504	PLUG, 1/2" NPT SQ. HEAD BRASS	1
4	102521	TEE, 3/4" NPT BRASS	1
5	102526	TEE, RED, 3/4" X 3/4" X 1/2" NPT BRASS	1
6	107550	VALVE, PRESSURE REGULATING, 3/4" NPT BRONZE	1
7	107967	HEX GRIP NUT, 1/4-20 SST W/NYLON	2
8	109926	FITTING, COMP. 5/8" OD X 1/2" MNPT, ELL BRASS	1
9	109879	FITTING, COMP. 7/8" OD X 3/4" MPT BRASS	1
10	110768	STRAINER, LINE 3/4" NPT BRONZE FEMALE	1
11	111437	VALVE, SOLENOID 3/4" NPT HW, 115VAC	1
---	114839	KIT, REPAIR, 3/4" SOLENOID VALVE	A/R
---	111472	COIL, SOLENOID 3/4" 115VAC	A/R
12	A511-8	BRACKET, 3/4" PIPE	2

Fill Piping - No Booster (Beginning with S/N J10012728 and above)

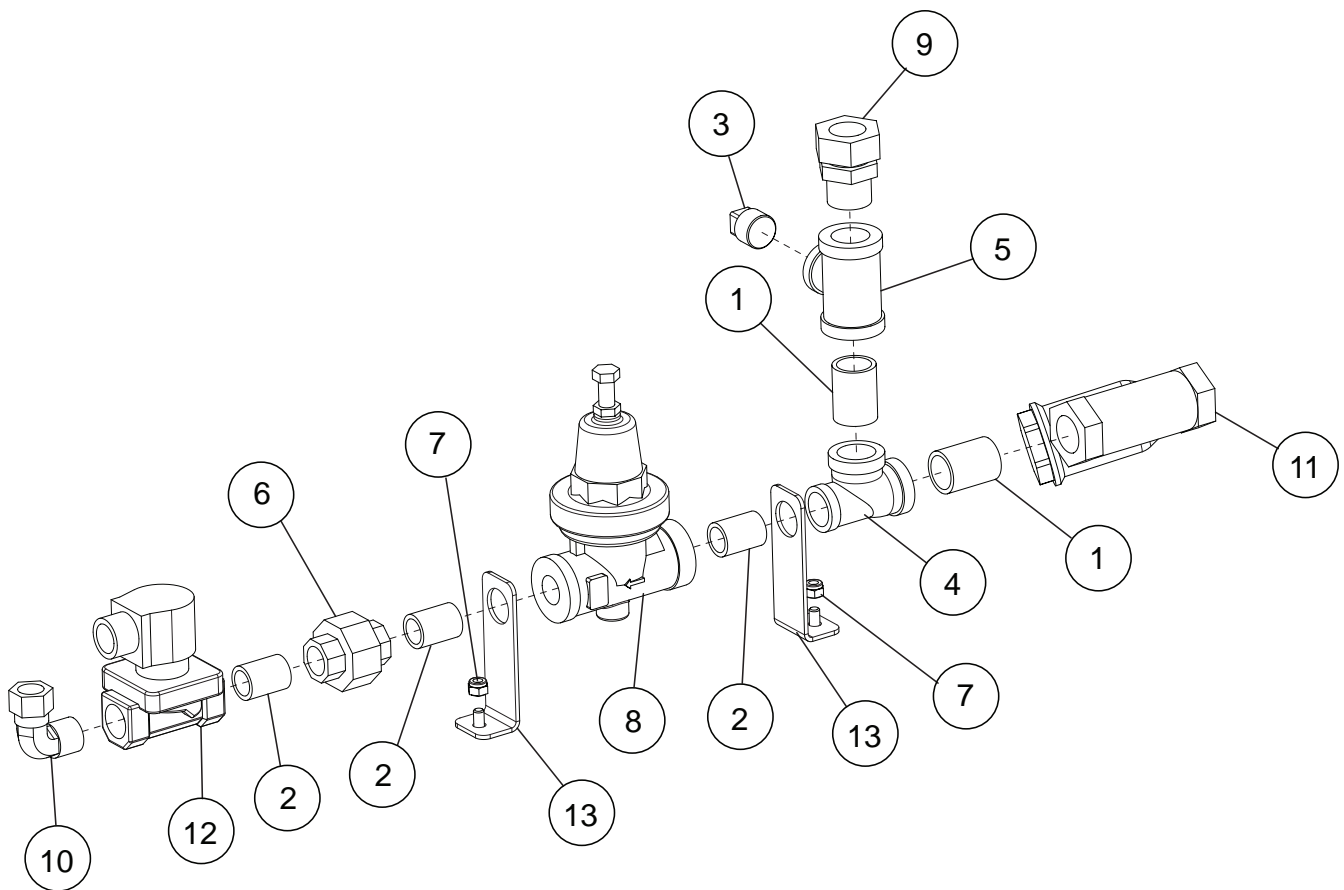



Fill Piping - No Booster (Beginning with S/N J10012728 and above)

Item No.	Part No.	Description	Qty.
1	100184	NIPPLE, 3/4" NPT X CLOSE BRASS	2
2	100209	NIPPLE, 1/2" NPT X CLOSE BRASS	3
3	102504	PLUG, 1/2" NPT SQ. HEAD, BRASS	1
4	102525	TEE, RED. 3/4" X 1/2" X 3/4" NPT BRASS	1
5	102526	TEE, RED. 3/4" X 3/4" X 1/2" NPT BRASS	1
6	102549	UNION, 1/2" NPT BRASS	1
7	107967	HEX GRIP NUT, 1/4-20 SST W/NYLON	2
8	108265	VALVE, PRESSURE REGULATING, 1/2" NPT BRONZE	1
9	109879	FITTING, COMP. 7/8" OD X 3/4" MPT BRASS	1
10	109926	FITTING, COMP. 5/8" OD X 1/2" MNPT ELL BRASS	1
11	110768	STRAINER, LINE 3/4" NPT BRONZE FEMALE	1
12	113352	VALVE, SOLENOID 1/2" NPT HW 115VAC	1
---	113392	KIT, REPAIR 1/2" SOLENOID VALVE	A/R
---	113357	COIL, SOLENOID 1/2" 115VAC	A/R
13	332454	BRACKET, 1/2" PIPE SUPPORT	2

#120-1 Steam Booster Installation RL

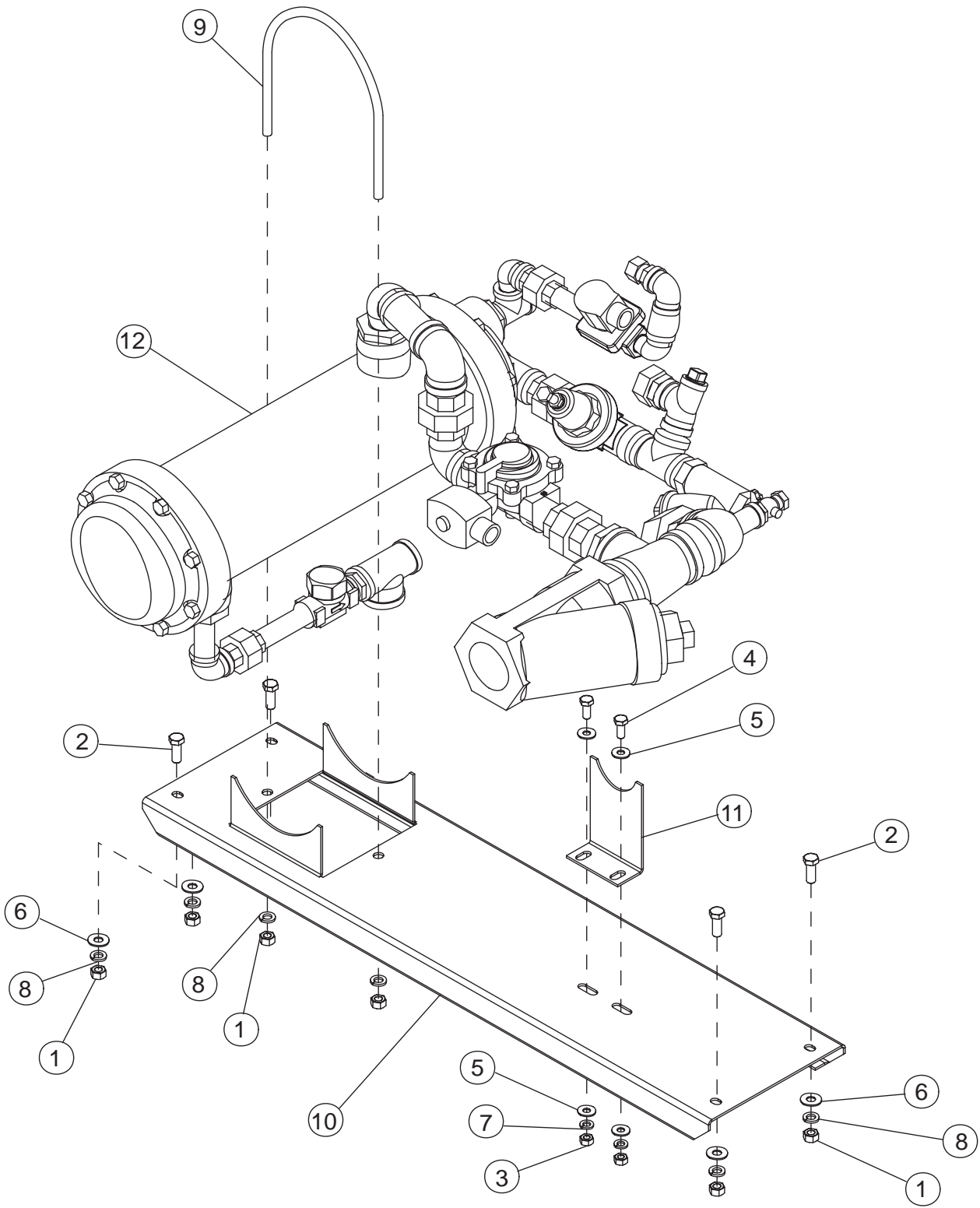

Item No.	Part No.	Description	Qty.
1	100140	HEX PLAIN NUT,3/8-16 SST	6
2	100153	HEX HEAD,3/8-16 X 1 SST	4
3	100154	HEX PLAIN NUT,5/16-18 SST	2
4	100739	HEX HEAD,5/16-18 X 3/4 SST	2
5	102376	WASHER,FLAT,5/16x3/4x.06 SST	4
6	104618	WASHER,FLAT,3/8x7/8x.06 SST	4
7	106013	WASHER,LOCK,5/16 SPLIT,SST	2
8	106407	WASHER,LOCK,3/8 SPLIT,SST	6
9	112334	U-BOLT,#180 BOOSTER	1
10	330244	BASE DECK DEVP,STEAM BOOSTER EUCCW	1
---	331533	BASE DECK DEVP,STEAM BOOSTER EUCC	1
11	330245	SUPORT,STRAINER,STEAM BOOSTER	1
12	601829	BOOSTER SUB ASSY,STEAM,#120-1 RL (See next page for 601829 parts breakdown)	1

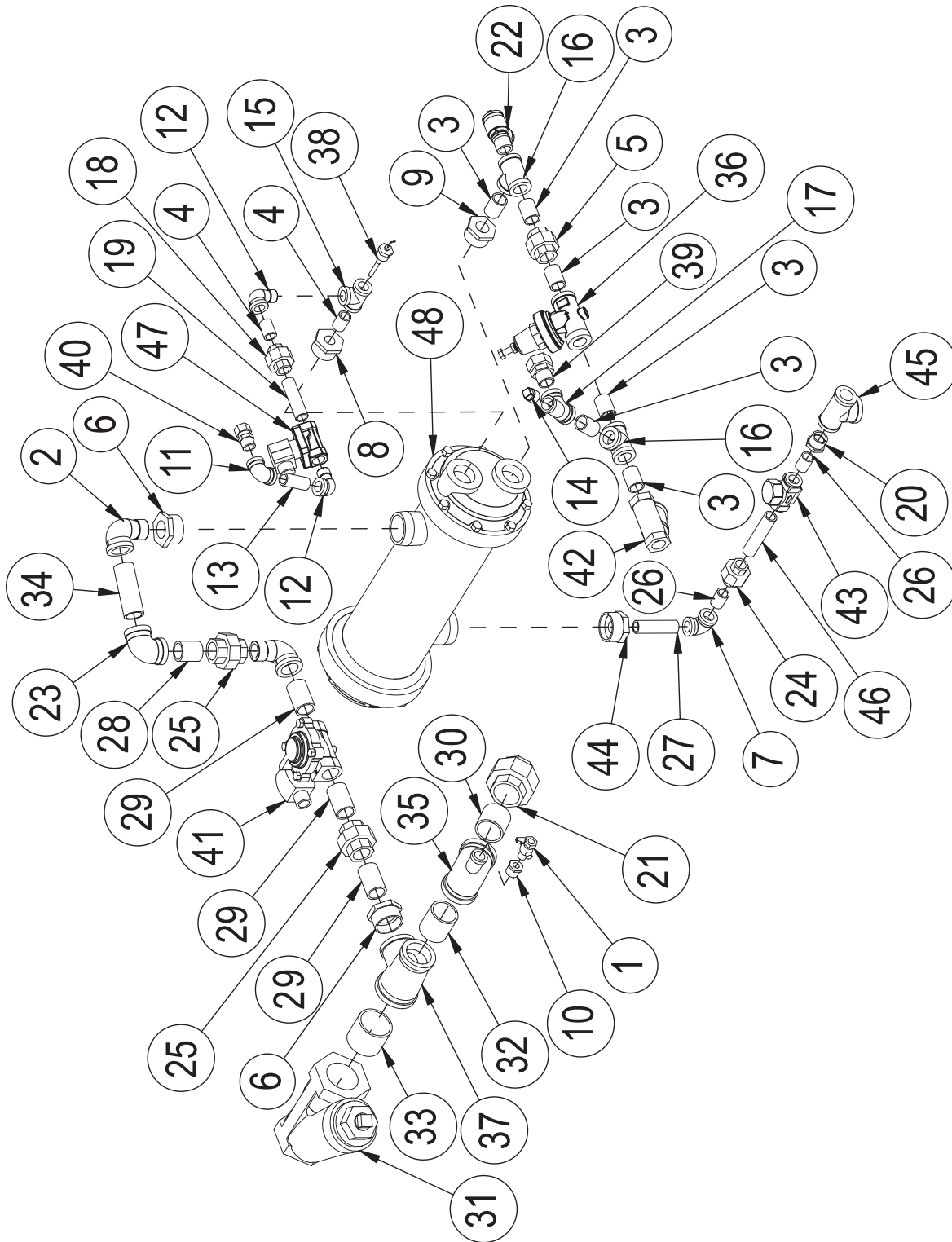

Item No.	Part No.	Description	Qty.
1	100123	PETCOCK,1/4"NPT FEMALE,BRASS	1
2	100134	ELBOW,STREET,1NPT X 90,MI	2
3	100184	NIPPLE,3/4"NPT X CLOSE,BRASS	6
4	100209	NIPPLE,1/2"NPT X CLOSE,BRASS	2
5	100571	UNION,3/4"NPT,BRASS	1
6	100979	BUSHING,REDUCING,1 1/2"NPTx1"NPT,BI	2
7	102288	ELBOW,1/2"NPT X 90 DEG,M.I.	1
8	102398	BUSHING,REDUCING,1 1/4"NPTx1/2"NPT,BRASS	1
9	102399	BUSHING,REDUCING,1 1/4"NPTx3/4"NPT,BRASS	1
10	102402	BUSHING,REDUCING,1/2"NPTx1/4"NPT,BI	1
11	102435	ELBOW, 1/2"NPT x 90 DEG,BRASS	1
12	102438	ELBOW,STREET,1/2"NPT X 90, BRASS	2
13	102492	NIPPLE,1/2"NPT X 2"LG.,BRASS	1
14	102504	PLUG,1/2"NPT SQ.HEAD,BRASS	1
15	102514	TEE, 1/2"NPT, BRASS	1
16	102521	TEE, 3/4"NPT, BRASS	2
17	102525	TEE,RED,3/4"x1/2"x3/4"NPT, BRASS	1
18	102549	UNION,1/2"NPT,BRASS	1
19	102567	NIPPLE,1/2"NPT X 3"LG.,BRASS	1
20	103465	BUSHING,REDUCING,3/4"NPTx1/2"NPT,BI	1
21	103586	UNION,1 1/2"NPT, MALLEABLE IRON	1
22	104649	VALVE,PRESSURE RELIEF,3/4" NPT BRONZE	1
23	105733	ELBOW,1"NPT X 90 DEG,M.I.	1
24	105778	UNION,1/2"NPT	1

(Parts continued on next page)

#120-1 Steam Booster Assembly RL 40-70°F

Item No.	Part No.	Description	Qty.
25	105780	UNION,1"NPT, MALLEABLE IRON	2
26	105782	NIPPLE,1/2"NPT X CLOSE.,B.I.	2
27	105786	NIPPLE,1/2"NPT X 3" LG.,B.I.	1
28	105847	NIPPLE,1"NPT X CLOSE,B.I.	1
29	105850	NIPPLE,1"NPT X 2" LG.,B.I.	3
30	105881	NIPPLE,1 1/2"NPT X CLOSE,B.I.	1
31	106051	STRAINER,LINE,2"NPT B.I.	1
32	106428	NIPPLE,1 1/2"NPT X 2" LG.,B.I.	1
33	106607	NIPPLE,2"NPT X CLOSE,B.I.	1
34	106789	NIPPLE,1"NPT X 3 1/2" LG.,B.I.	1
35	107004	TEE,RED,1 1/2"x1/2"x1 1/2", MI	1
36	107550	VALVE,PRESSURE REGULATING,3/4"NPT BRONZE	1
37	107657	TEE,RED,2" X 1 1/2" X 1 1/2" NPT,BI	1
38	109069	THERMOSTAT,W/CAPILLARY	1
39	109879	FITTING, COMP 7/8 OD X 3/4 MPT BRASS	1
40	109925	FITTING, COMP 5/8 OD X 1/2 MPT BRASS	1
41	110005 110007	1" STEAM VALVE IS NO LONGER AVAILABLE REPAIR KIT, ASCO VALVE NO. L8220G007 ONLY	1
----	114800 114830	1" ASCO STEAM VALVE (ASCO # L8220G410) REPAIR KIT, ASCO VALVE NO. L8220G410 ONLY	1
42	110768	STRAINER,LINE,3/4"NPT BRONZE FEMALE	1
43	111380	STEAM TRAP,1/2"NPT TDC	1
44	112349	BUSHING,REDUCING,1 1/2"NPTx1/2"NPT,BI	1
45	112359	TEE,RED,3/4" X 3/4" X 1" NPT,BI	1
46	112748	NIPPLE,1/2"NPT X 3 3/4" LG.,B.I.	1
47	113352	VALVE 1/2" NPT SOLENOID 115V	1
---	113392	REPAIR KIT, 1/2" SOLENOID VALVE	A/R
---	113357	COIL, 1/2" SOLENOID VALVE 115VAC	A/R
48	114167	BOOSTER,THRUSH #120-1	1

***This Page  
Intentionally  
Left Blank***

#120-1 Steam Booster Installation LR

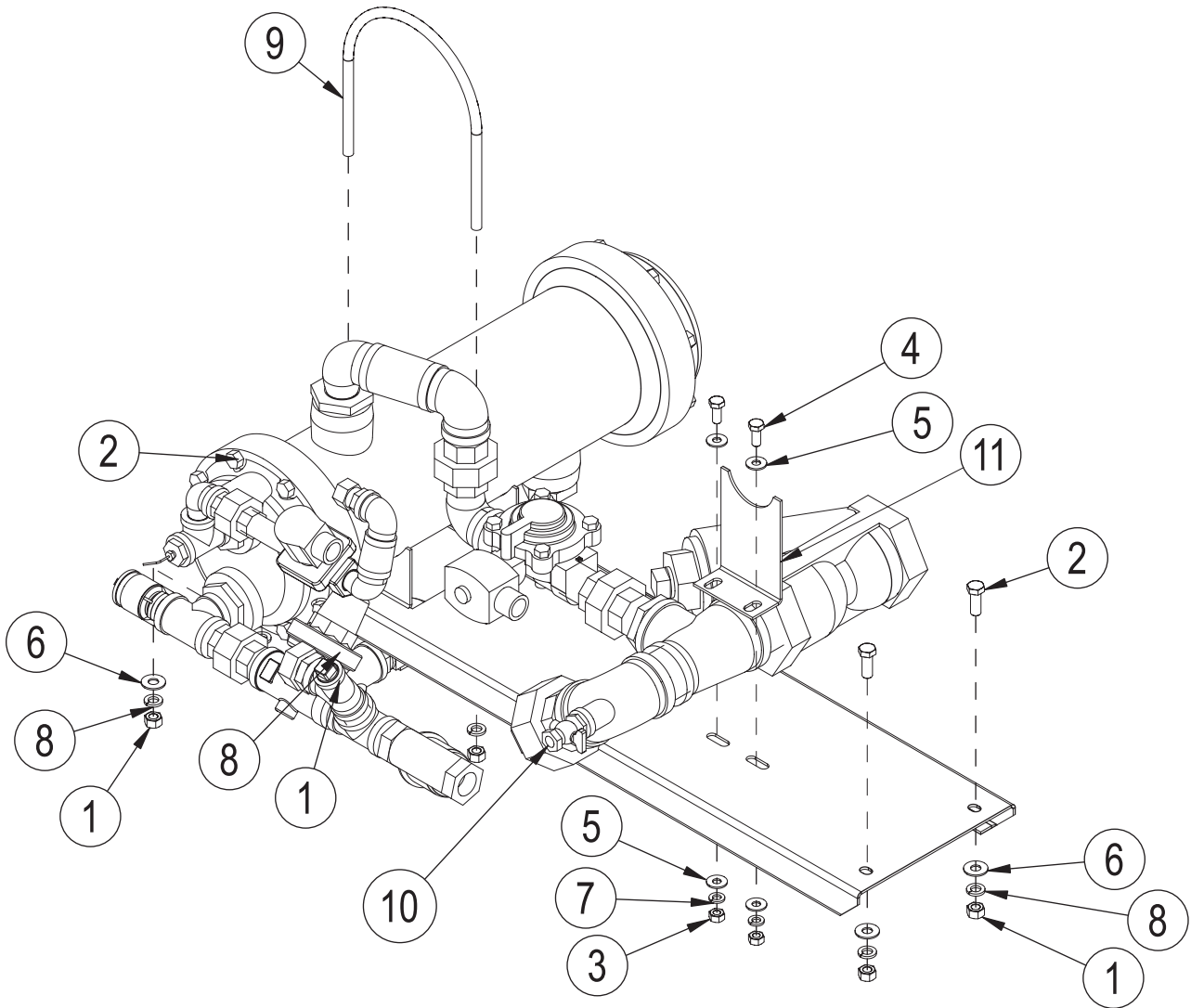



Item No.	Part No.	Description	Qty.
1	100140	HEX PLAIN NUT,3/8-16 SST	6
2	100153	HEX HEAD,3/8-16 X 1 SST	4
3	100154	HEX PLAIN NUT,5/16-18 SST	2
4	100739	HEX HEAD,5/16-18 X 3/4 SST	2
5	102376	WASHER,FLAT,5/16x3/4x.06 SST	4
6	104618	WASHER,FLAT,3/8x7/8x.06 SST	4
7	106013	WASHER,LOCK,5/16 SPLIT,SST	2
8	106407	WASHER,LOCK,3/8 SPLIT,SST	6
9	112334	U-BOLT,#180 BOOSTER	1
10	330244	BASE DECK DEVP,STEAM BOOSTER EUCCW	1
---	331533	BASE DECK DEVP,STEAM BOOSTER EUCC	1
11	330245	SUPORT,STRAINER,STEAM BOOSTER	1

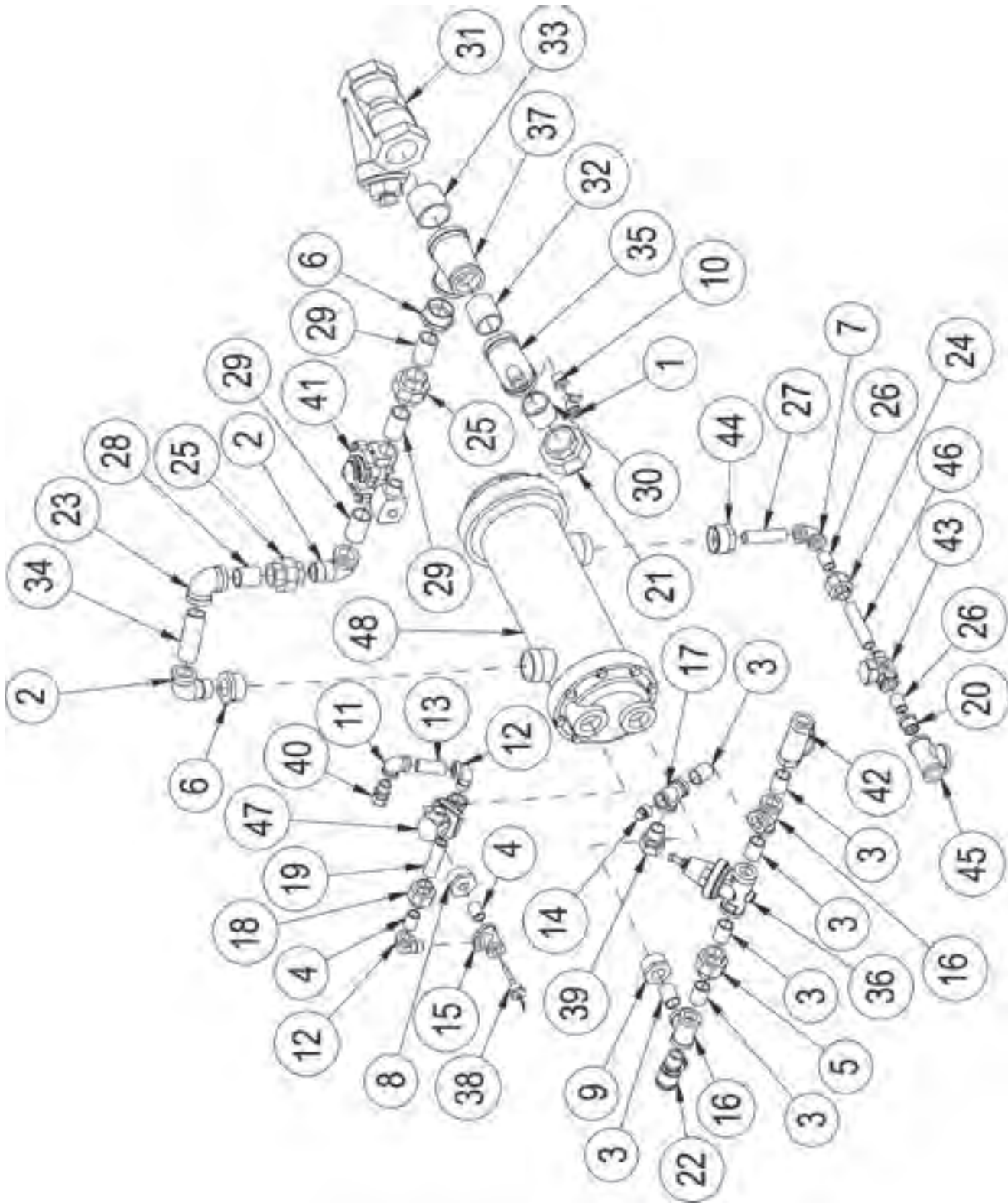

Item No.	Part No.	Description	Qty.
1	100123	PETCOCK,1/4"NPT FEMALE,BRASS	1
2	100134	ELBOW,STREET,1NPT X 90,MI	2
3	100184	NIPPLE,3/4"NPT X CLOSE,BRASS	6
4	100209	NIPPLE,1/2"NPT X CLOSE,BRASS	2
5	100571	UNION,3/4"NPT,BRASS	1
6	100979	BUSHING,REDUCING,1 1/2"NPTx1"NPT,BI	2
7	102288	ELBOW,1/2"NPT X 90 DEG,M.I.	1
8	102398	BUSHING,REDUCING,1 1/4"NPTx1/2"NPT,BRASS	1
9	102399	BUSHING,REDUCING,1 1/4"NPTx3/4"NPT,BRASS	1
10	102402	BUSHING,REDUCING,1/2"NPTx1/4"NPT,BI	1
11	102435	ELBOW, 1/2"NPT x 90 DEG,BRASS	1
12	102438	ELBOW,STREET,1/2"NPT X 90, BRASS	2
13	102492	NIPPLE,1/2"NPT X 2"LG.,BRASS	1
14	102504	PLUG,1/2"NPT SQ.HEAD,BRASS	1
15	102514	TEE, 1/2"NPT, BRASS	1
16	102521	TEE, 3/4"NPT, BRASS	2
17	102525	TEE,RED,3/4"x1/2"x3/4"NPT, BRASS	1
18	102549	UNION,1/2"NPT,BRASS	1
19	102567	NIPPLE,1/2"NPT X 3"LG.,BRASS	1
20	103465	BUSHING,REDUCING,3/4"NPTx1/2"NPT,BI	1
21	103586	UNION,1 1/2"NPT, MALLEABLE IRON	1
22	104649	VALVE,PRESSURE RELIEF,3/4" NPT BRONZE	1
23	105733	ELBOW,1"NPT X 90 DEG,M.I.	1
24	105778	UNION,1/2"NPT	1

(Parts continued on next page)

#120-1 Steam Booster Assembly LR 40-70°F

Item No.	Part No.	Description	Qty.
25	105780	UNION,1"NPT, MALLEABLE IRON	2
26	105782	NIPPLE,1/2"NPT X CLOSE.,B.I.	2
27	105786	NIPPLE,1/2"NPT X 3" LG.,B.I.	1
28	105847	NIPPLE,1"NPT X CLOSE,B.I.	1
29	105850	NIPPLE,1"NPT X 2" LG.,B.I.	3
30	105881	NIPPLE,1 1/2"NPT X CLOSE,B.I.	1
31	106051	STRAINER,LINE,2"NPT B.I.	1
32	106428	NIPPLE,1 1/2"NPT X 2" LG.,B.I.	1
33	106607	NIPPLE,2"NPT X CLOSE,B.I.	1
34	106789	NIPPLE,1"NPT X 3 1/2" LG.,B.I.	1
35	107004	TEE,RED,1 1/2"x1/2"x1 1/2", MI	1
36	107550	VALVE,PRESSURE REGULATING,3/4"NPT BRONZE	1
37	107657	TEE,RED,2" X 1 1/2" X 1 1/2" NPT,BI	1
38	109069	THERMOSTAT,W/CAPILLARY	1
39	109879	FITTING, COMP 7/8 OD X 3/4 MPT BRASS	1
40	109925	FITTING, COMP 5/8 OD X 1/2 MPT BRASS	1
41	110005 110007	1" STEAM VALVE IS NO LONGER AVAILABLE REPAIR KIT, ASCO VALVE NO. L8220G007 ONLY	1
----	114800 114830	1" ASCO STEAM VALVE (ASCO # L8220G410) REPAIR KIT, ASCO VALVE NO. L8220G410 ONLY	1
42	110768	STRAINER,LINE,3/4"NPT BRONZE FEMALE	1
43	111380	STEAM TRAP,1/2"NPT TDC	1
44	112349	BUSHING,REDUCING,1 1/2"NPTx1/2"NPT,BI	1
45	112359	TEE,RED,3/4" X 3/4" X 1" NPT,BI	1
46	112748	NIPPLE,1/2"NPT X 3 3/4" LG.,B.I.	1
47	113352	VALVE 1/2" NPT SOLENOID 115V	1
---	113392	REPAIR KIT, 1/2" SOLENOID VALVE	A/R
---	113357	COIL, 1/2" SOLENOID VALVE 115VAC	A/R
48	114167	BOOSTER,THRUSH #120-1	1

***This Page  
Intentionally  
Left Blank***

Steam Coil Heat Installation C4 Wash, Rinse, 15-30 PSI

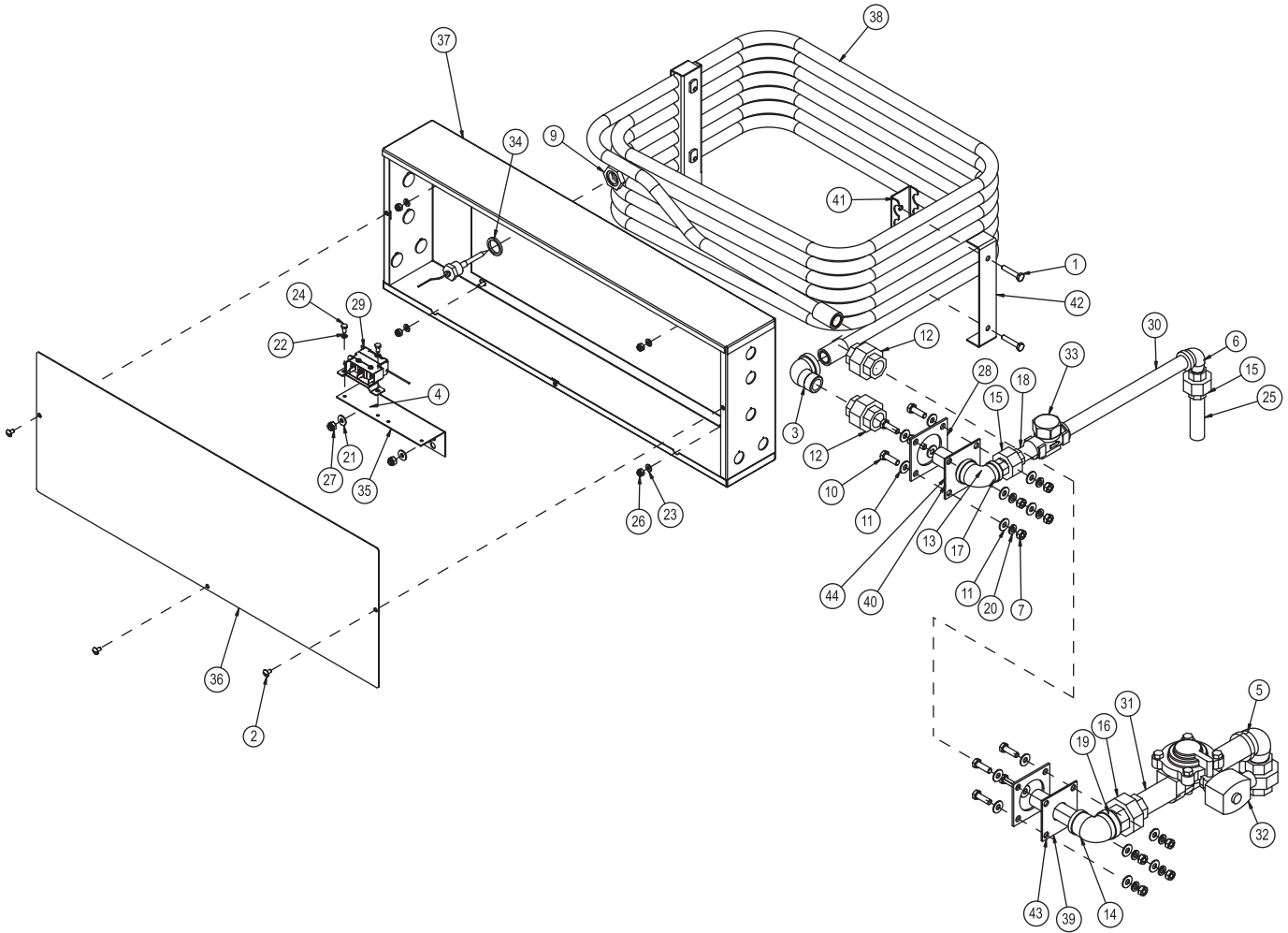

Steam Coil Heat Installation C4 Wash, Rinse, 15-30 PSI

Item No.	Part No.	Description	Qty.
1	100002	BOLT, HEX HD. 1/4-20 X 1-3/8" SST	4
2	100007	SCREW, TRUSS HEAD, 10-32 X 3/8" SST	3
3	100023	STREET, ELBOW 3/4" NPT X 90° SST	1
4	100109	WELD STUD, 1/4-20 X 1/2" LG. SST	1
5	100134	ELBOW, STREET, 1" NPT X 90° MI	1
6	100147	ELBOW, STREET, 1/2" NPT X 90° MI	1
7	100154	HEX PLAIN NUT, 5/16-18 SST	8
8	100198	WELD STUD, 10-32 X 1/2" SST	4
9	100547	LOCKNUT, 1/2" NPT SST	1
10	100740	BOLT, HEX HD., 5/16-18 X 1" SST	8
11	102376	WASHER, FLAT 5/16" SST	16
12	102554	UNION, 3/4" NPT SST	2
13	105738	ELBOW, REDUCING 1" NPT X 1/2" NPT X 90° MI	1
14	105739	ELBOW, REDUCING, 1" NPT X 3/4" NPT X 90° MI	1
15	105778	UNION, 1/2" NPT MI	2
16	105780	UNION, 1" NPT MI	2
17	105782	NIPPLE, 1/2" NPT X CLOSE BI	1
18	105783	NIPPLE, 1/2" NPT X 2" LG. BI	1
19	105847	NIPPLE, 1" NPT X CLOSE BI	1
20	106013	WASHER, LOCK 5/16" SPLIT SST	8
21	106026	WASHER, FLAT 1/4" SST	2
22	106486	WASHER, LOCK #10 SPLIT, SST	2
23	107033	WASHER, FLAT .208" X .438" X .047" SST	4
24	107136	SCREW, HEX HD., 10-32 X 3/8" SST	2
25	107488	NIPPLE, 1/2" NPT X 3-1/2" LG. BI	1
26	107966	HEX GRIP NUT, 10-32 SST W/NYLON INSERT	4
27	107967	HEX GRIP NUT, 1/4-20 SST W/NYLON INSERT	2
28	108345	GASKET, HEATER/STANDPIPE	2
29	109069	THERMOSTAT, CONTROL WITH CAPILLARY	1
30	109580	NIPPLE, 1/2" NPT X 11" LG. BI	1
31	109969	NIPPLE, 1" NPT X 3-3/4" LG BI	2
32	110005	VALVE, 1" ASCO (NO LONGER AVAILABLE)	1
	110007	REPAIR KIT, 1" ASCO VALVE # L8220G007 ONLY	A/R
---	114800	VALVE, 1" ASCO STEAM ASCO # L8220G410	1
	114830	REPAIR KIT, 1" ASCO VALVE # L8SS0G410 ONLY	A/R
33	111380	STEAM TRAP, 1/2" NPT TDC	1
34	201041	WASHER, SPACER 7/8" X 1-3/16" X 1/8" NP	1
35	323430	BRACKER, THERMOSTAT	1
36	329768	COVER, HEATER BOX C4-BKT	1
37	329769	HEATER BOX WELDMENT, C4-B	1
38	330129	STEAM COIL WELDMENT, C4-HP	1
39	330242	FLANGE, WELDMENT STEAM, C3/C4 HP	1
40	330243	FLANGE, WELDMENT, CONDENSATE C3/C4 HP	1
41	330362	BRACKET, WELDMENT C4, STEAM COIL	2
42	330363	CAP, DEVELOPMENT STEAM COIL BRACKET	2

Steam Coil Heat Installation C3 Wash, Rinse, 15-30 PSI

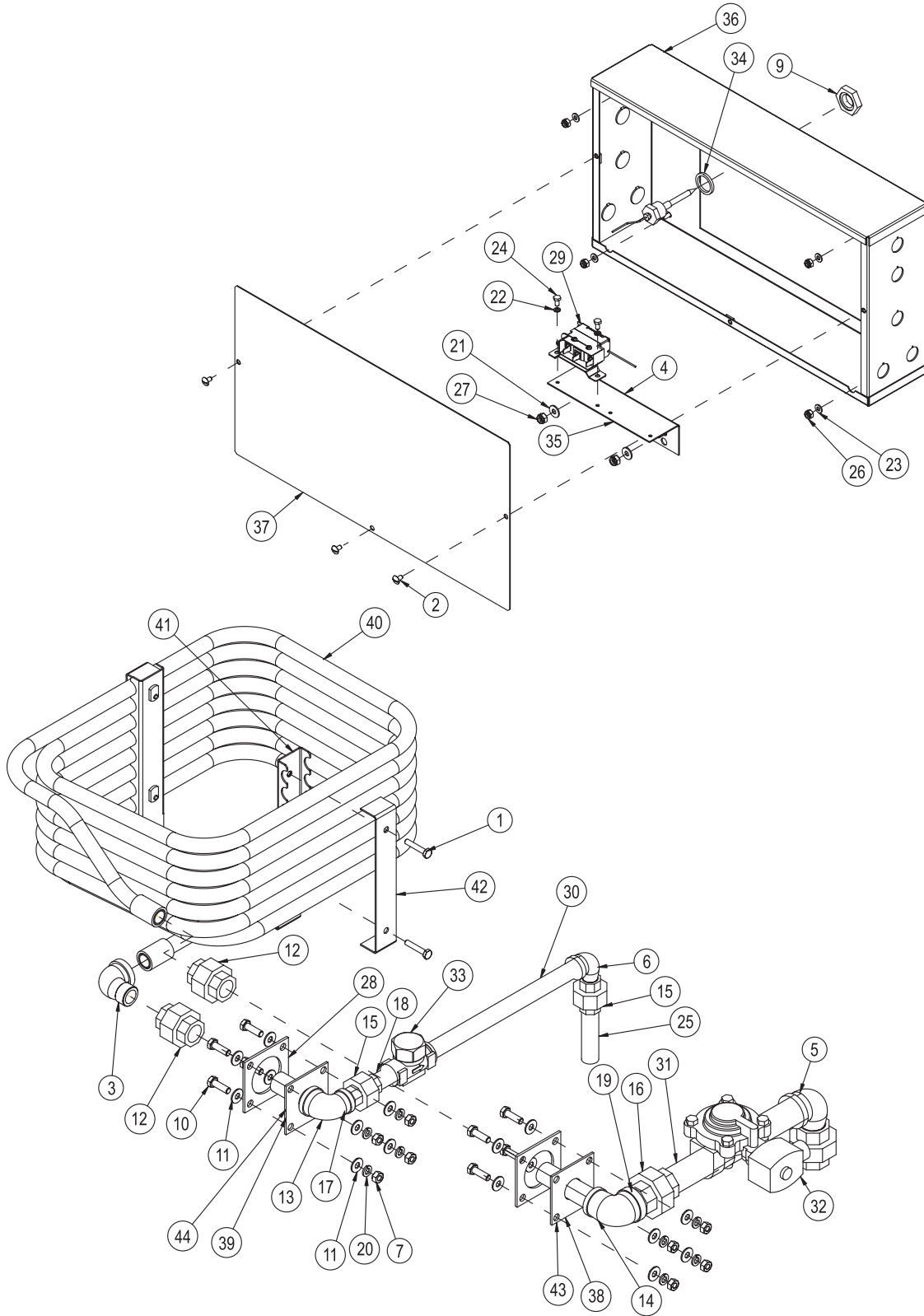



Item No.	Part No.	Description	Qty.
1	100002	HEX HEAD,1/4-20 X 1 3/8 SST	4
2	100007	SCREW,TRUSS HEAD,10-32 x 3/8 SST	3
3	100023	STREET ELBOW,3/4"NPT X 90,SST	1
4	100109	WELD-STUD,1/4-20 X 1/2 LG.SST	2
5	100134	ELBOW,STREET,1NPT X 90,MI	1
6	100147	ELBOW,STREET,1/2NPT X 90,MI	1
7	100154	HEX PLAIN NUT,5/16-18 SST	8
8	100198	WELD-STUD,10-32 X 1/2 LG.SST	4
9	100547	LOCKNUT,1/2" NPT,SST	1
10	100740	HEX HEAD,5/16-18 X 1 SST	8
11	102376	WASHER,FLAT,5/16x3/4x.06 SST	16
12	102554	UNION,3/4"NPT, SST	2
13	105738	ELBOW,REDUCING,3/4"NPT X 1/2"NPT X 90,M.I.	1
14	105739	ELBOW,REDUCING,1"NPT X 3/4"NPT X 90,M.I.	1
15	105778	UNION,1/2"NPT, MALLEABLE IRON	2
16	105780	UNION,1"NPT, MALLEABLE IRON	2
17	105782	NIPPLE,1/2"NPT X CLOSE.,B.I.	1
18	105783	NIPPLE,1/2"NPT X 2" LG.,B.I.	1
19	105847	NIPPLE,1"NPT X CLOSE,B.I.	1
20	106013	WASHER,LOCK,5/16 SPLIT,SST	8
21	106026	WASHER,FLAT,1/4x5/8x.06 SST	2
22	106486	WASHER,LOCK,#10 SPLIT,SST	2

***(Parts list continued on next page)***

Steam Coil Heat Installation C3 Wash, Rinse, 15-30 PSI

Item No.	Part No.	Description	Qty.
23	107033	WASHER,FLAT,.208X.438X.047 SST	4
24	107136	SCREW,HEX HEAD,10-32 x 3/8 SST	2
25	107488	NIPPLE,1/2"NPT X 3 1/2" LG.,B.I.	1
26	107966	HEX GRIP NUT,10-32 SST W/NYLON	4
27	107967	HEX GRIP NUT,1/4-20 SST W/NYLON	2
28	108345	GASKET,HEATER/STANDPIPE	2
29	109069	THERMOSTAT,CONTROL,WITH CAPILLARY	1
30	109580	NIPPLE,1/2"NPT X 11" LG.,B.I. EUCCW	1
---	105796	NIPPLE,1/2"NPT X 7" LG.,B.I. EUCC	1
31	109969	NIPPLE,1"NPT X 3 3/4" LG.,B.I. EUCCW	2
---	105850	NIPPLE,1"NPT X 2" LG.,B.I. EUCC	2
32	110005	VALVE,1"NPT STEAM,ACSO (NO LONGER AVAILABLE)	1
	110007	REPAIR KIT, 1" ASCO STEAM VALVE # L8220G007 ONLY	A/R
32	114800	VALVE,1"NPT STEAM,ASCO # L8220G410	1
	114830	REPAIR KIT, 1" ASCO STEAM VALVE # L8220G410 ONLY	A/R
33	111380	STEAM TRAP,1/2"NPT TDC	1
34	201041	WASHER,SPACER,7/8x1 3/16x1/8 NP	1
35	323430	BRACKET, THERMOSTATS,USN72,44CR	1
36	330217	HEATER BOX WELDMENT,C3-B	1
37	330218	COVER,HEATER BOX,C3-BKT	1
38	330242	FLANGE WELDMENT,STEAM,C3/C4 HP	1
39	330243	FLANGE WELDMENT,CONDENSATE,C3/C4 HP	1
40	331116	STEAM COIL WELDMENT,C3 HP	1
41	331117	BRACKET WELDMENT,C3 STEAM COIL	2
42	331118	CAP DEVP,STEAM COIL BRACKET,C3	2
43	601798	PIPING SUB-ASSY,STEAM,C3/C4	1
---	601798	PIPING SUB-ASSY,STEAM,C3/C4	1
44	601804	PIPING SUB-ASSY,CONDENSATE,C3/C4	1
---	601804	PIPING SUB-ASSY,CONDENSATE,C3/C4	1

***This Page  
Intentionally  
Left Blank***

Steam Coil Heat Installation Auxiliary, 15-30 PSI

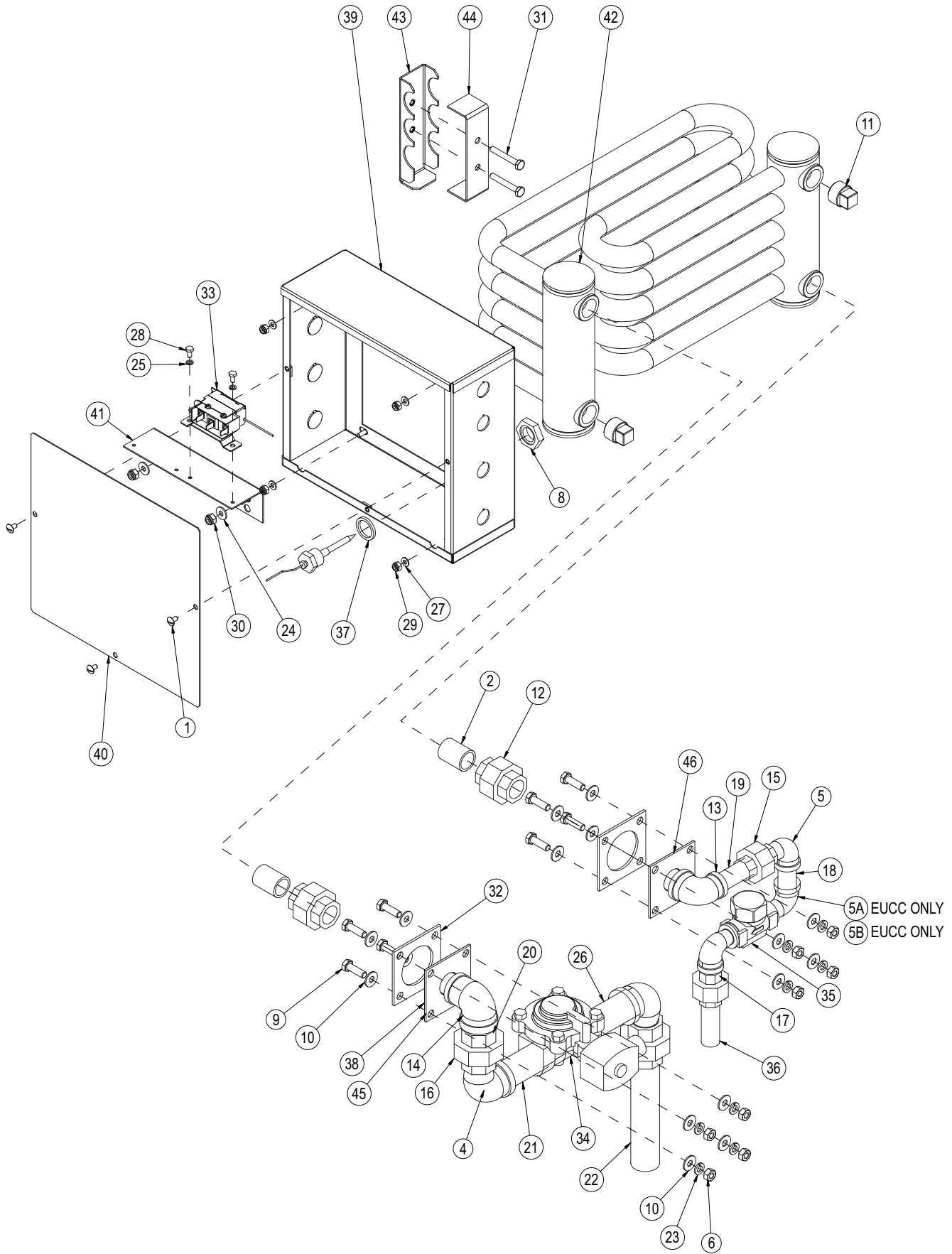

Item No.	Part No.	Description	Qty.
1	100007	SCREW, TRUSS HEAD, 10-32 x 3/8 SST	3
2	100051	NIPPLE, 3/4" NPT X CLOSE, SST	2
3	100109	WELD-STUD, 1/4-20 X 1/2 LG. SST	2
4	100134	ELBOW, STREET, 1 NPT X 90, MI	2
5	100147	ELBOW, STREET, 1/2 NPT X 90, MI	3
5A	102288	ELBOW, 1/2 NPT X 90, MI EUCC	3
5B	107488	NIPPLE, 1/2 NPT X 3-1/2" LG. B.I. EUCC	3
6	100154	HEX PLAIN NUT, 5/16-18 SST	8
7	100198	WELD-STUD, 10-32 X 1/2 LG. SST	4
8	100547	LOCKNUT, 1/2" NPT, SST	1
9	100740	HEX HEAD, 5/16-18 X 1 SST	8
10	102376	WASHER, FLAT, 5/16x3/4x.06 SST	16
11	102506	PLUG, 3/4" NPT SQ. HEAD, SST	2
12	102554	UNION, 3/4" NPT, SST	2
13	105738	ELBOW, REDUCING, 3/4" NPT X 1/2" NPT X 90, M.I.	1
14	105739	ELBOW, REDUCING, 1" NPT X 3/4" NPT X 90, M.I.	1
15	105778	UNION, 1/2" NPT, MALLEABLE IRON	2
16	105780	UNION, 1" NPT, MALLEABLE IRON	2
17	105782	NIPPLE, 1/2" NPT X CLOSE., B.I.	1
18	105783	NIPPLE, 1/2" NPT X 2" LG., B.I.	1
19	105785	NIPPLE, 1/2" NPT X 2 1/2" LG., B.I. EUCCW	1
---	105782	NIPPLE, 1" NPT X CLOSE, B.I. EUCC	1
20	105847	NIPPLE, 1" NPT X CLOSE, B.I.	1
21	105854	NIPPLE, 1" NPT X 3 1/4" LG., B.I.	1
---	105847	NIPPLE, 1" NPT X CLOSE, B.I. EUCC	1
22	105863	NIPPLE, 1" NPT X 6 1/2" LG., B.I.	1
23	106013	WASHER, LOCK, 5/16 SPLIT, SST	8

(Parts list continued on next page)

Steam Coil Heat Installation Auxiliary, 15-30 PSI

Item No.	Part No.	Description	Qty.
24	106026	WASHER,FLAT,1/4x5/8x.06 SST	2
25	106486	WASHER,LOCK,#10 SPLIT,SST	2
26	106789	NIPPLE,1"NPT X 3 1/2" LG.,B.I. EUCCW	1
---	105847	NIPPLE,1"NPT X CLOSE, B.I. EUCC	1
27	107033	WASHER,FLAT,.208X.438X.047 SST	4
28	107136	SCREW,HEX HEAD,10-32 x 3/8 SST	2
29	107966	HEX GRIP NUT,10-32 SST W/NYLON	4
30	107967	HEX GRIP NUT,1/4-20 SST W/NYLON	2
31	107999	HEX HEAD,1/4-20 X 1 3/4 SST	2
32	108345	GASKET,HEATER/STANDPIPE	2
33	109069	THERMOSTAT,CONTROL,WITH CAPILLARY	1
34	110005	VALVE, 1" ASCO (NO LONGER AVAILABLE)	1
	110007	REPAIR KIT, 1" ASCO VALVE # L8220G007 ONLY	A/R
---	114800	VALVE, 1" ASCO STEAM ASCO # L8220G410	1
	114830	REPAIR KIT, 1" ASCO VALVE # L8SS0G410 ONLY	A/R
35	111380	STEAM TRAP,1/2"NPT TDC	1
36	112508	NIPPLE,1/2"NPT X 2 3/4" LG.,B.I.	1
37	201041	WASHER,SPACER,7/8x1 3/16x1/8 NP	1
38	307404	FLANGE WELDMENT,STEAM,UCC/CW	2
39	322811	HEATER BOX WELDMENT,AUX.- B	1
40	322812	COVER,HEATER BOX,AUX.-BKT	1
41	323430	BRACKET, THERMOSTATS,USN72,44CR	1
42	330130	STEAM COIL WELDMENT,AUX. LP/HP	1
43	330246	BRACKET WELDMENT,STEAM COIL, AUXILIARY	1
44	330247	CAP,STEAM COIL BRACKET, AUXILIARY	1
45	601827	PIPING ASSY,STEAM, AUXILIARY RINSE, LR EUCCW	1
---	601827	PIPING ASSY,STEAM, AUXILIARY RINSE, LR EUCC	1
46	601828	PIPING ASSY,COND, AUX. RINSE, LR EUCCW	1
---	601828	PIPING ASSY,COND, AUX. RINSE, LR EUCC	1
---	601869	PIPING ASSY,STEAM, AUXILIARY RINSE, RL EUCC	1
---	601824	PIPING ASSY,STEAM, AUXILIARY RINSE, RL EUCCW	1
---	601870	PIPING ASSY,COND., AUXILIARY RINSE, RL EUCC	1
---	601825	PIPING ASSY,COND., AUXILIARY RINSE, RL EUCCW	1

***This Page  
Intentionally  
Left Blank***

Steam Injector Heat Installation C4/C8, 15-30 PSI

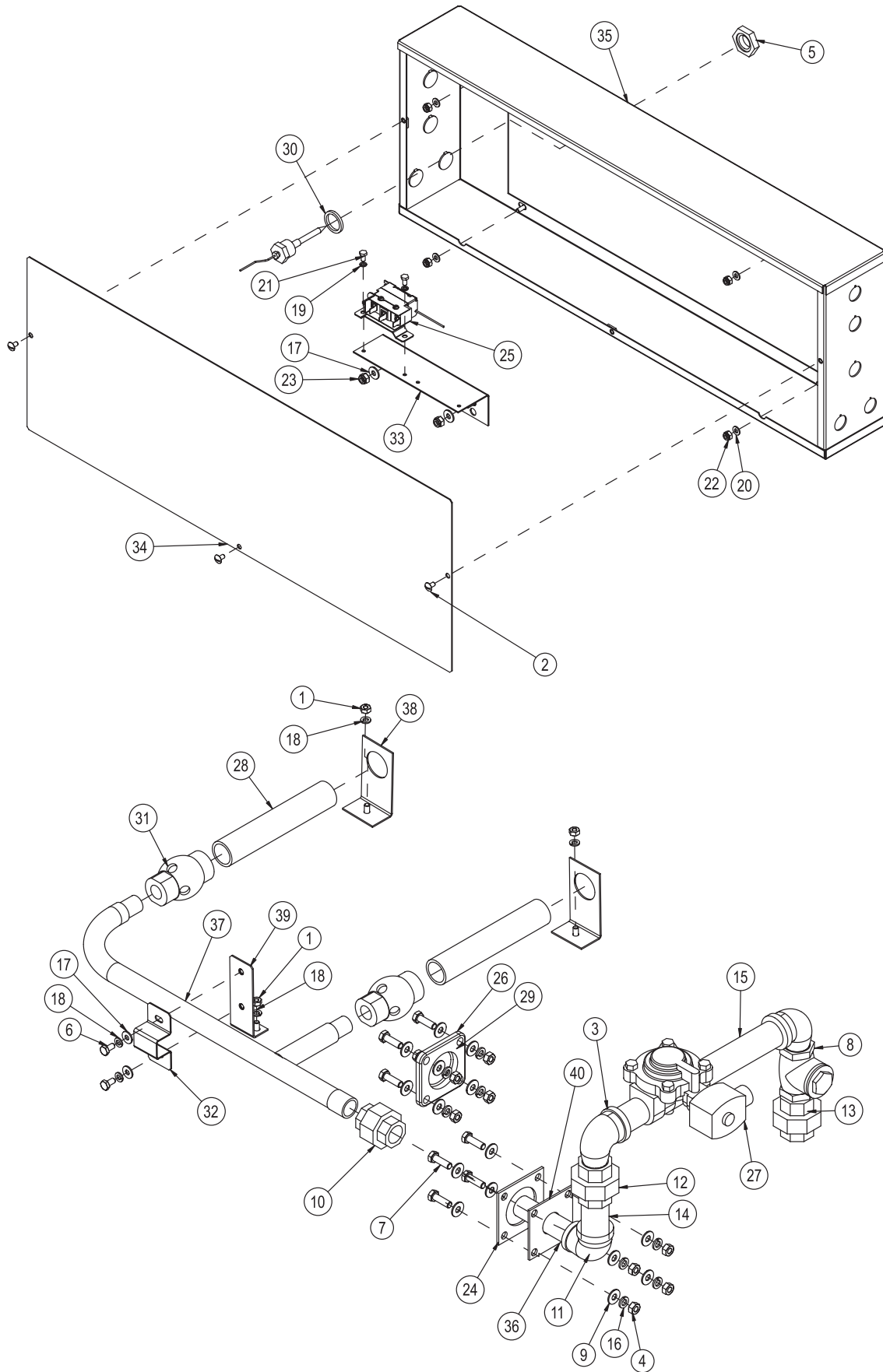



Item No.	Part No.	Description	Qty.
1	100003	HEX PLAIN NUT,1/4-20 SST	4
2	100007	SCREW,TRUSS HEAD,10-32 x 3/8 SST	3
3	100134	ELBOW,STREET,1NPT X 90,MI	2
4	100154	HEX PLAIN NUT,5/16-18 SST	8
5	100547	LOCKNUT,1/2" NPT,SST	1
6	100734	HEX HEAD,1/4-20 X 1/2 SST	2
7	100740	HEX HEAD,5/16-18 X 1 SST	8
8	100854	CHECK VALVE,1" NPT BRONZE	1
9	102376	WASHER,FLAT,5/16x3/4x.06 SST	16
10	102554	UNION,3/4"NPT, SST	1
11	105739	ELBOW,REDUCING,1"NPT X 3/4"NPT X 90,M.I.	1
12	105780	UNION,1"NPT, MALLEABLE IRON	2
13	105847	NIPPLE,1"NPT X CLOSE,B.I.	1
14	105853	NIPPLE,1"NPT X 3" LG.,B.I.	2
15	105863	NIPPLE,1"NPT X 6 1/2" LG.,B.I. EUCCW	1
15	105853	NIPPLE,1"NPT X 3" LG.,B.I. EUCC	1
16	106013	WASHER,LOCK,5/16 SPLIT,SST	8
17	106026	WASHER,FLAT,1/4x5/8x.06 SST	4
18	106482	WASHER,LOCK,1/4 SPLIT,SST	6
19	106486	WASHER,LOCK,#10 SPLIT,SST	2
20	107033	WASHER,FLAT,.208X.438X.047 SST	4

(Parts list continued on next page)

Steam Injector Heat Installation C4/C8, 15-30 PSI

Item No.	Part No.	Description	Qty.
21	107136	SCREW,HEX HEAD,10-32 x 3/8 SST	2
22	107966	HEX GRIP NUT,10-32 SST W/NYLON	4
23	107967	HEX GRIP NUT,1/4-20 SST W/NYLON	2
24	108345	GASKET,HEATER/STANDPIPE	1
25	109069	THERMOSTAT,CONTROL,WITH CAPILLARY	1
26	109683	FLANGE,BLOCKOFF,HEATER/CROSSFLOW	1
27	110005 110007	VALVE, 1" ASCO (NO LONGER AVAILABLE) REPAIR KIT, 1" ASCO VALVE # L8220G007 ONLY	1 A/R
---	114800 114830	VALVE, 1" ASCO STEAM ASCO # L8220G410 REPAIR KIT, 1" ASCO VALVE # L8SS0G410 ONLY	1 A/R
28	111371	NIPPLE,TOE,1"NPT X 7"LG.,SST	2
29	112257	O-RING,55.3 X 66.7 X 5.7	1
30	201041	WASHER,SPACER,7/8x1 3/16x1/8 NP	1
31	201110	STEAM INJECTOR	2
32	321512	CLAMP,STEAM INJECTOR BRACKET	1
33	323430	BRACKET, THERMOSTATS,USN72,44CR	1
34	329768	COVER,HEATER BOX,C4-BKT	1
35	329769	HEATER BOX WELDMENT,C4-B	1
36	330242	FLANGE WELDMENT,STEAM,C3/C4 HP	1
37	331175	MANIFOLD WELDMENT,EUC-4FT STEAM INJECTOR	1
38	331176	BRACKET,STEAM INJECTOR NIPPLE,C3/C4	2
39	331177	BRACKET WELDMENT,STEAM INJECTOR SUPPORT	1
40	601861	PIPING SUB-ASSY,STEAM INJECTOR,C3/C4 EUCCW	1
---	601868	PIPING SUB-ASSY,STEAM INJECTOR,C3/C4 EUCC	1

***This Page  
Intentionally  
Left Blank***

Steam Injector Heat Installation Auxiliary Rinse RL

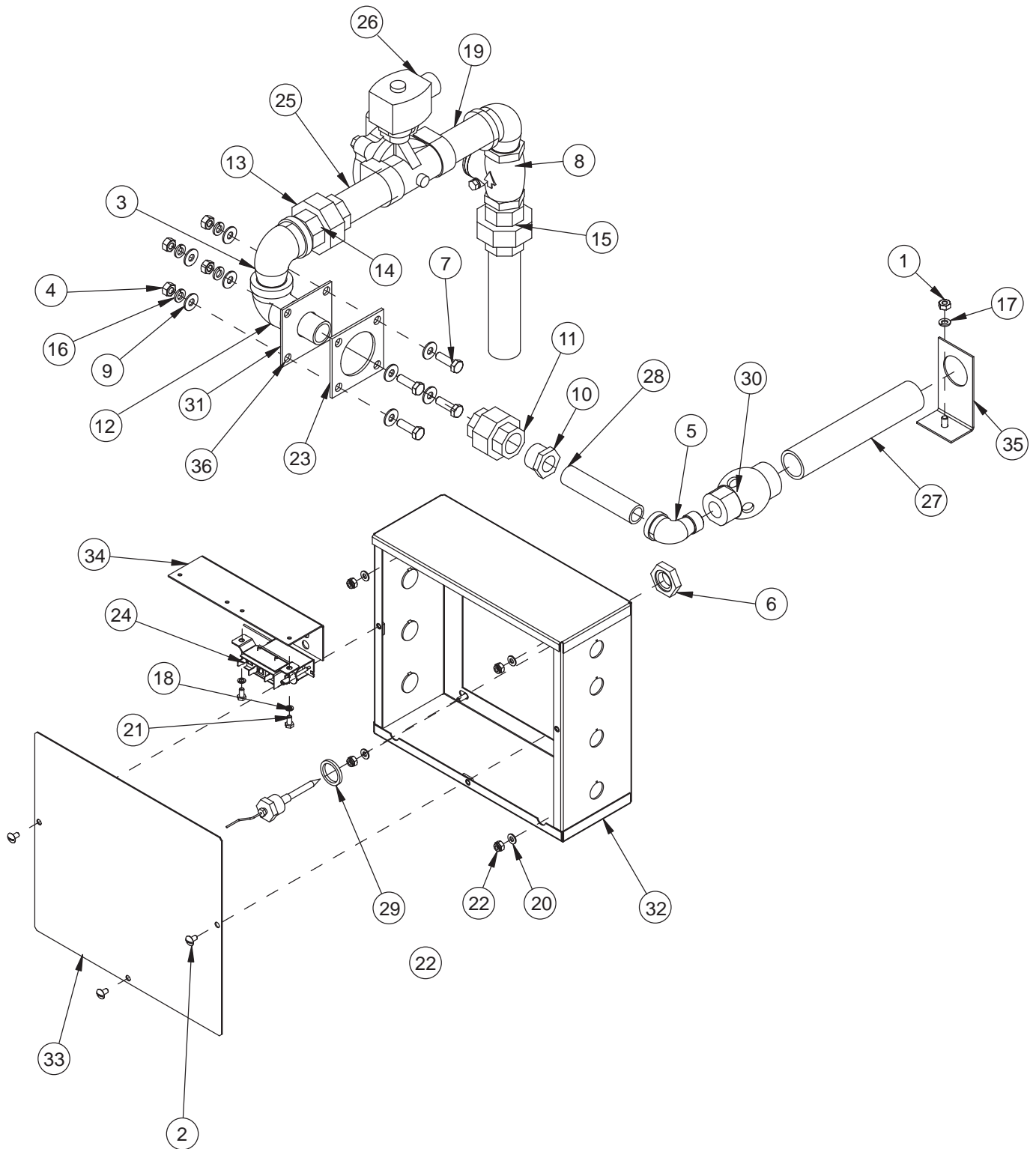

Item No.	Part No.	Description	Qty.
1	100003	HEX PLAIN NUT,1/4-20 SST	1
2	100007	SCREW,TRUSS HEAD,10-32 x 3/8 SST	3
3	100134	ELBOW,STREET,1NPT X 90,MI	2
4	100154	HEX PLAIN NUT,5/16-18 SST	4
5	100516	STREET ELBOW,1/2"NPT X 90,SST	1
6	100547	LOCKNUT,1/2" NPT,SST	1
7	100740	HEX HEAD,5/16-18 X 1 SST	4
8	100854	CHECK VALVE,1" NPT BRONZE	1
9	102376	WASHER,FLAT,5/16x3/4x.06 SST	8
10	102393	BUSHING,REDUCING,3/4"NPTx1/2"NPT,SST	1
11	102554	UNION,3/4"NPT, SST	1
12	105739	ELBOW,REDUCING,1"NPT X 3/4"NPT X 90,M.I.	1
13	105780	UNION,1"NPT, MALLEABLE IRON	2
14	105847	NIPPLE,1"NPT X CLOSE,B.I.	2
15	105861	NIPPLE,1"NPT X 6" LG.,B.I.	1
16	106013	WASHER,LOCK,5/16 SPLIT,SST	4
17	106482	WASHER,LOCK,1/4 SPLIT,SST	1
18	106486	WASHER,LOCK,#10 SPLIT,SST	2
19	106789	NIPPLE,1"NPT X 3 1/2" LG.,B.I. EUCCW	1
---	105847	NIPPLE,1"NPT X CLOSE, LG.,B.I. EUCC	1
20	107033	WASHER,FLAT,.208X.438X.047 SST	4
21	107136	SCREW,HEX HEAD,10-32 x 3/8 SST	2
22	107966	HEX GRIP NUT,10-32 SST W/NYLON	4
23	108345	GASKET,HEATER/STANDPIPE	1
24	109069	THERMOSTAT,CONTROL,WITH CAPILLARY	1
25	109969	NIPPLE,1"NPT X 3 3/4" LG.,B.I. EUCCW	1
---	105850	NIPPLE,1"NPT X 2" LG.,B.I. EUCC	1
26	110005	VALVE, 1" ASCO (NO LONGER AVAILABLE)	1
	110007	REPAIR KIT, 1" ASCO VALVE # L8220G007 ONLY	A/R
---	114800	VALVE, 1" ASCO STEAM ASCO # L8220G410	1
	114830	REPAIR KIT, 1" ASCO VALVE # L8SS0G410 ONLY	A/R
27	111371	NIPPLE,TOE,1"NPT X 7"LG.,SST	1
28	112259	NIPPLE,1/2"NPT X 4"LG.,SST	1
29	201041	WASHER,SPACER,7/8x1 3/16x1/8 NP	1
30	201110	STEAM INJECTOR	1
31	307404	FLANGE WELDMENT,STEAM,UCC/CW	1
32	322811	HEATER BOX WELDMENT,E2-B	1
33	322812	COVER,HEATER BOX,E2-BKT	1
34	323430	BRACKET, THERMOSTATS,USN72,44CR	1
35	331176	BRACKET,STEAM INJECTOR NIPPLE,C3/C4	1
36	601862	PIPING ASSY,STEAM INJECTOR,E2 RL EUCCW	1
---	601873	PIPING ASSY,STEAM INJECTOR,E2 RL EUCC	1

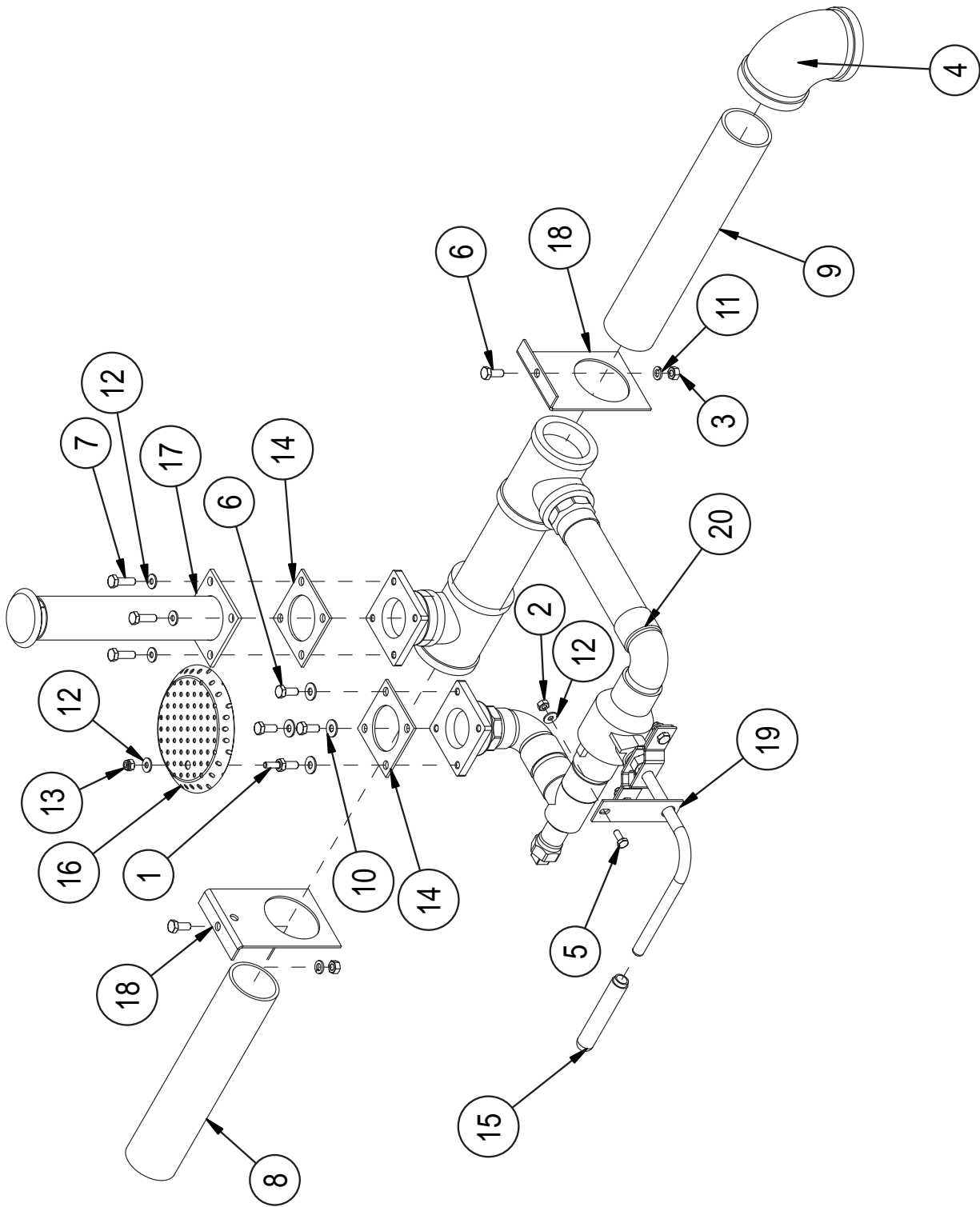

Item No.	Part No.	Description	Qty.
1	100110	WELD-STUD,1/4-20 X 3/4 LG.SST	1
2	100141	HEX GRIP NUT,1/4-20 SST,CTR LOCK	1
3	100154	HEX PLAIN NUT,5/16-18 SST	2
4	100161	ELBOW,2"NPT X 90,GALVANIZED	1
5	100735	HEX HEAD,1/4-20 X 5/8 SST	1
6	100739	HEX HEAD,5/16-18 X 3/4 SST	6
7	100740	HEX HEAD,5/16-18 X 1 SST	4
8	101939	NIPPLE,TOE,2"NPT X 11" LG.,GALV	1
9	101944	NIPPLE,2"NPT X 12 1/2" LG.,GALV	1
10	102376	WASHER,FLAT,5/16x3/4x.06 SST	4
11	106013	WASHER,LOCK,5/16 SPLIT,SST	2
12	106026	WASHER,FLAT,1/4x5/8x.06 SST	6
13	107967	HEX GRIP NUT,1/4-20 SST W/NYLON	1
14	108345	GASKET,HEATER/STANDPIPE	2
15	114185	GRIP,DRAIN HANDLE	1
16	304816	STRAINER,DRAIN	1
17	305840	OVERFLOW WELDMENT, 9.50 UC	1
18	310259	BRACKET, DRAIN LINE SUPPORT,UC'S	2
19	329677	SUPPORT BRACKET,DRAIN HANDLE	1
20	601819	DRAIN SUB-ASSY,PW,2" TRUNK EUCCW	1
---	601838	DRAIN SUB-ASSY,PW,2" TRUNK EUCC	1

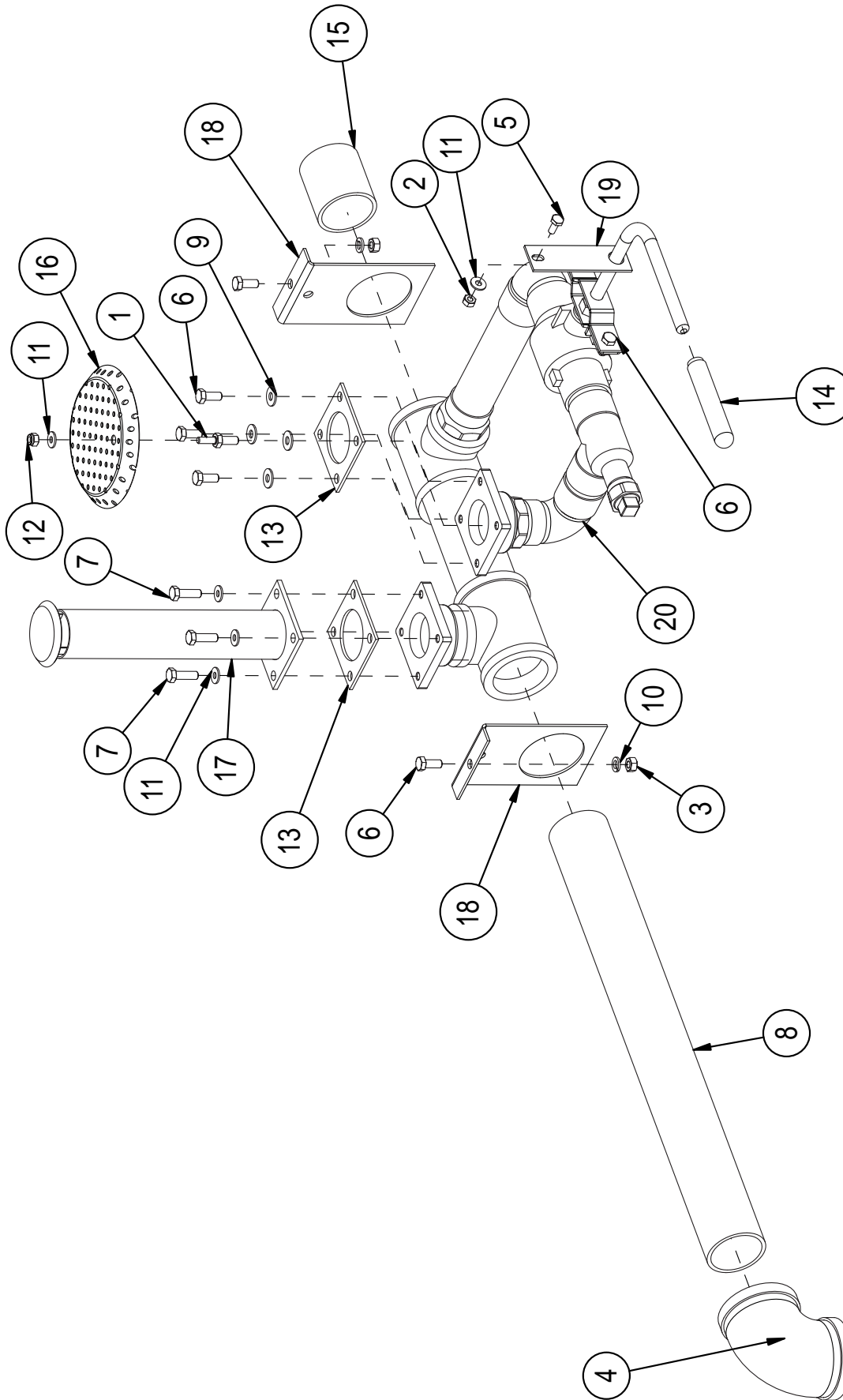



Item No.	Part No.	Description	Qty.
1	100110	WELD-STUD,1/4-20 X 3/4 LG.SST	1
2	100141	HEX GRIP NUT,1/4-20 SST,CTR LOCK	1
3	100154	HEX PLAIN NUT,5/16-18 SST	2
4	100161	ELBOW,2"NPT X 90,GALVANIZED	1
5	100735	HEX HEAD,1/4-20 X 5/8 SST	1
6	100739	HEX HEAD,5/16-18 X 3/4 SST	6
7	100740	HEX HEAD,5/16-18 X 1 SST	4
8	101954	NIPPLE,2"NPT X 21 1/2" LG.,GALV	1
9	102376	WASHER,FLAT,5/16x3/4x.06 SST	4
10	106013	WASHER,LOCK,5/16 SPLIT,SST	2
11	106026	WASHER,FLAT,1/4x5/8x.06 SST	6
12	107967	HEX GRIP NUT,1/4-20 SST W/NYLON	1
13	108345	GASKET,HEATER/STANDPIPE	2
14	114185	GRIP,DRAIN HANDLE	1
15	114198	NIPPLE,TOE,2"NPT X 2 1/2" LG.,GALV	1
16	304816	STRAINER,DRAIN	1
17	305840	OVERFLOW WELDMENT, 9.50 UC	1
18	310259	BRACKET, DRAIN LINE SUPPORT,UC'S	2
19	329677	SUPPORT BRACKET,DRAIN HANDLE	1
20	601819	DRAIN SUB-ASSY,PW,2" TRUNK EUCCW	1
---	601838	DRAIN SUB-ASSY,PW,2" TRUNK EUCC	1

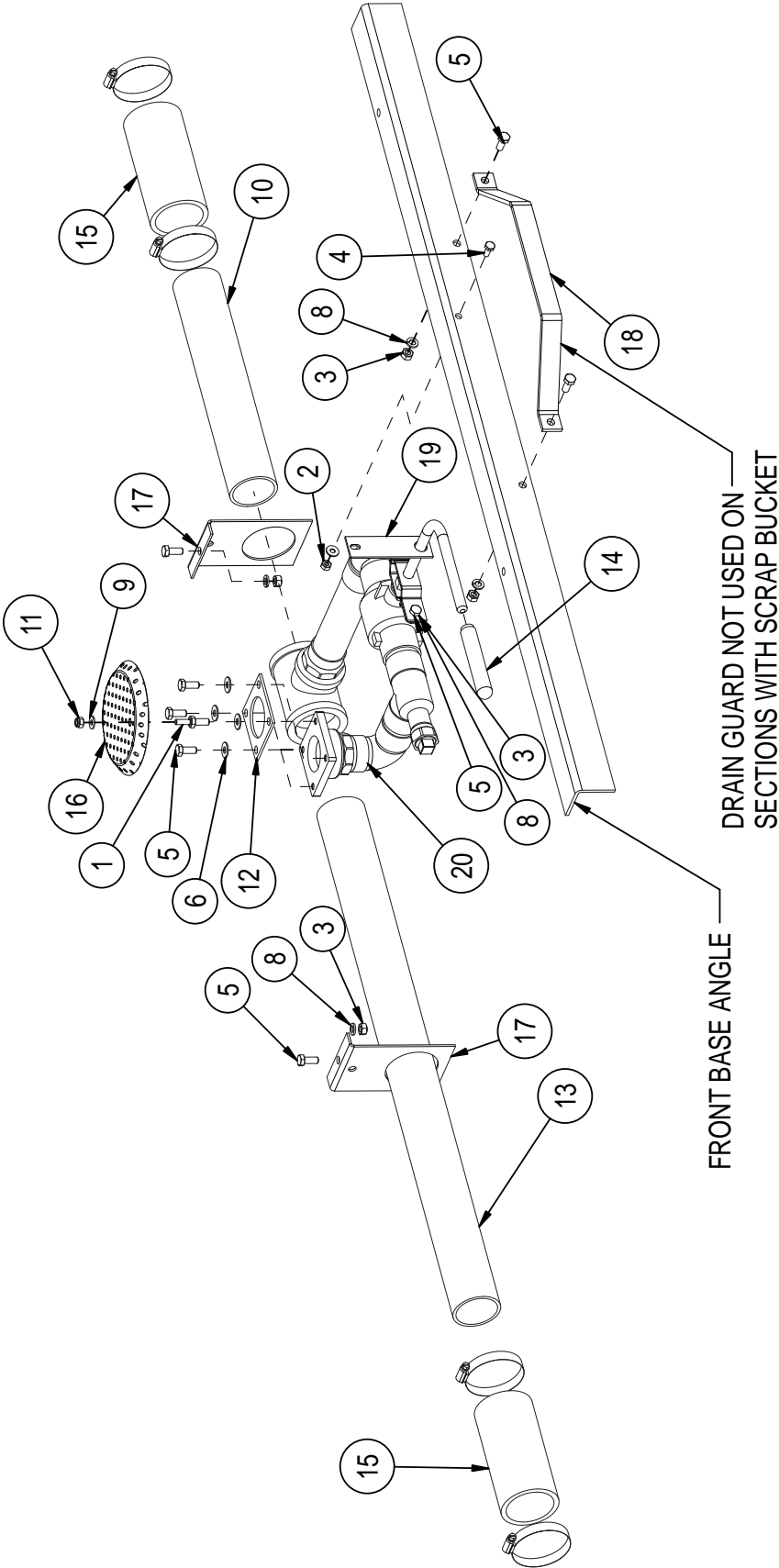

Item No.	Part No.	Description	Qty.
1	100110	WELD-STUD,1/4-20 X 3/4 LG.SST	1
2	100141	HEX GRIP NUT,1/4-20 SST,CTR LOCK	1
3	100154	HEX PLAIN NUT,5/16-18 SST	4
4	100735	HEX HEAD,1/4-20 X 5/8 SST	1
5	100739	HEX HEAD,5/16-18 X 3/4 SST	8
6	102376	WASHER,FLAT,5/16x3/4x.06 SST	4
7	104165	CLAMP,HOSE,M40,52/76,SST GEAR TYPE	4
8	106013	WASHER,LOCK,5/16 SPLIT,SST	4
9	106026	WASHER,FLAT,1/4x5/8x.06 SST	2
10	106631	NIPPLE,TOE,2"NPT X 12 3/4" LG.,GALV	1
11	107967	HEX GRIP NUT,1/4-20 SST W/NYLON	1
12	108345	GASKET,HEATER/STANDPIPE	1
13	114101	NIPPLE,TOE,2"NPT X 30 1/2" LG.,GALV	1
14	114185	GRIP,DRAIN HANDLE	1
15	202073	HOSE,2.375 ID X 6.000 LG.EPDM	2
16	304816	STRAINER,DRAIN	1
17	310259	BRACKET, DRAIN LINE SUPPORT,UC'S	2
18	329130	GUARD, DRAIN VALVE	1
19	329677	SUPPORT BRACKET,DRAIN HANDLE	1
20	601820	DRAIN SUB-ASSY,W/R,2" TRUNK EUCCW	1
---	601839	DRAIN SUB-ASSY,W/R,2" TRUNK EUCC	1

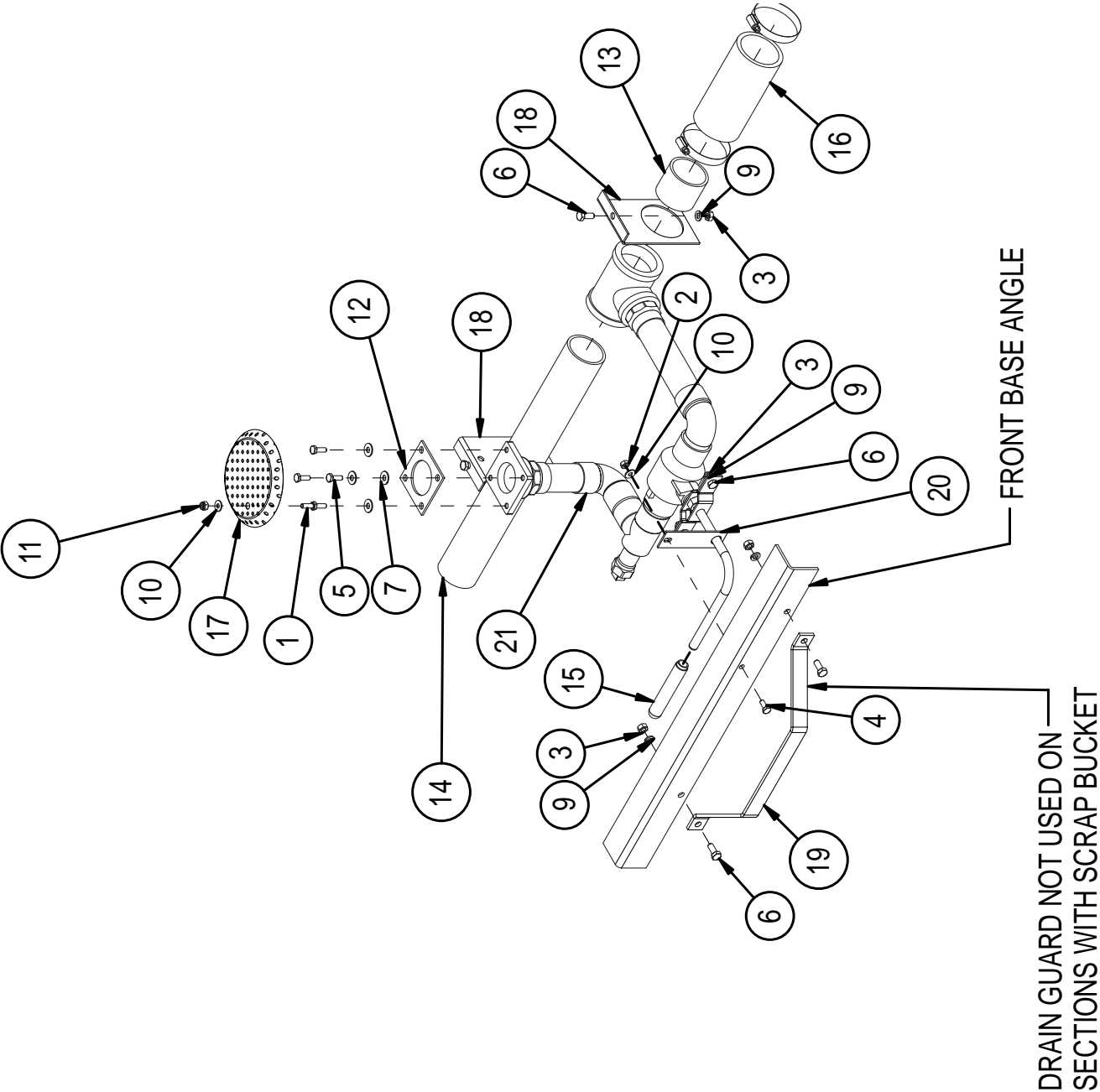

Item No.	Part No.	Description	Qty.
1	100110	WELD-STUD,1/4-20 X 3/4 LG.SST	1
2	100141	HEX GRIP NUT,1/4-20 SST,CTR LOCK	1
3	100154	HEX PLAIN NUT,5/16-18 SST	4
4	100735	HEX HEAD,1/4-20 X 5/8 SST	1
5	100736	HEX HEAD,1/4-20 X 3/4 SST	4
6	100739	HEX HEAD,5/16-18 X 3/4 SST	4
7	102376	WASHER,FLAT,5/16x3/4x.06 SST	4
8	104165	CLAMP,HOSE,M40,52/76,SST GEAR TYPE	2
9	106013	WASHER,LOCK,5/16 SPLIT,SST	4
10	106026	WASHER,FLAT,1/4x5/8x.06 SST	2
11	107967	HEX GRIP NUT,1/4-20 SST W/NYLON	1
12	108345	GASKET,HEATER/STANDPIPE	1
13	111903	NIPPLE,TOE,2"NPT X 2" LG.,GALV	1
14	114106	NIPPLE,TOE,2"NPT X 18" LG.,GALV	1
15	114185	GRIP,DRAIN HANDLE	1
16	202073	HOSE,2.375 ID X 6.000 LG.EPDM	1
17	304816	STRAINER,DRAIN	1
18	310259	BRACKET, DRAIN LINE SUPPORT,UC'S	2
19	329130	GUARD, DRAIN VALVE	1
20	329677	SUPPORT BRACKET,DRAIN HANDLE	1
21	601821	DRAIN SUB-ASSY,ECO-RINSE, 2" TRUNK EUCCW	1
--	601840	DRAIN SUB-ASSY,ECO-RINSE, 2" TRUNK EUCC	1

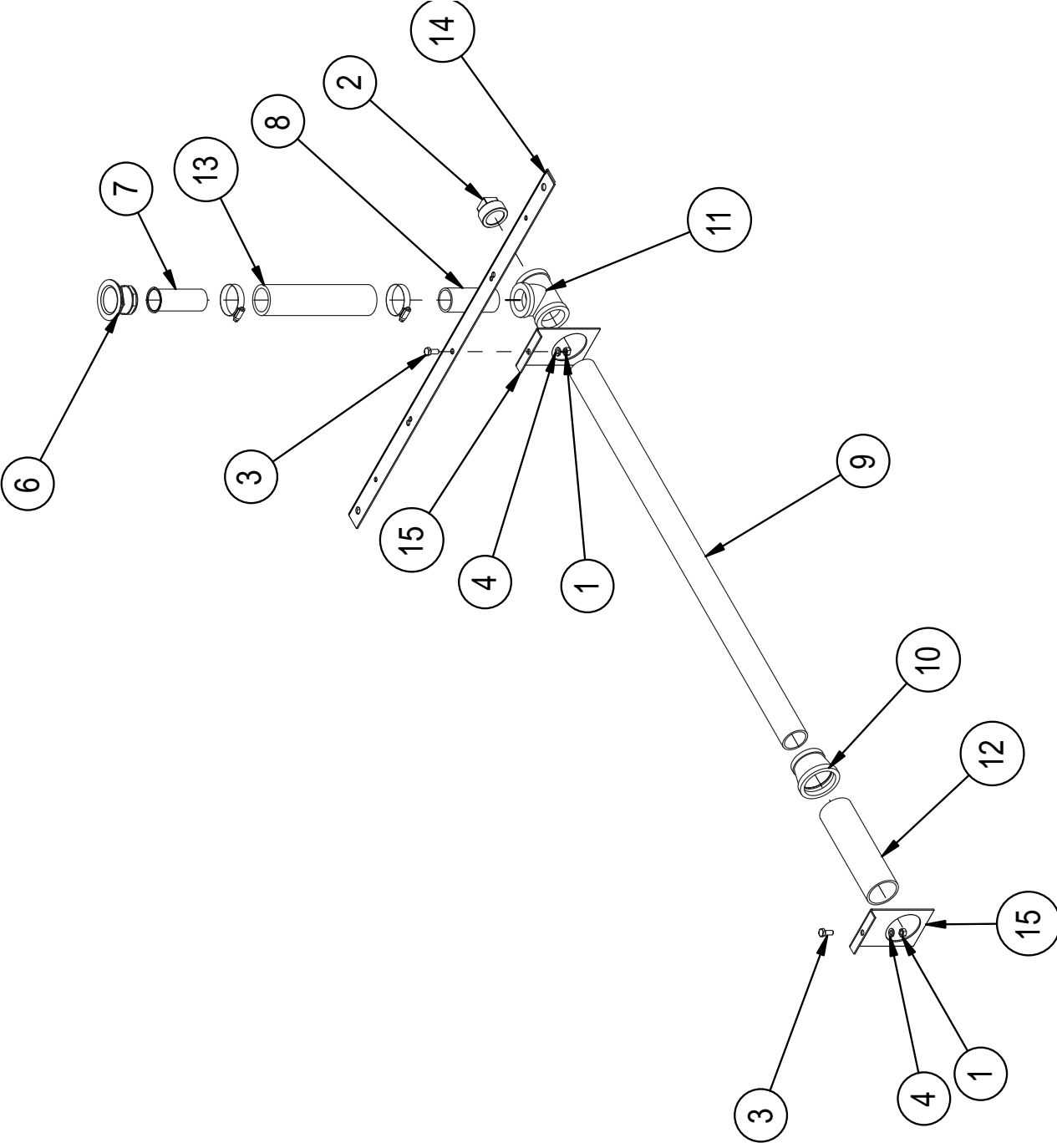

Item No.	Part No.	Description	Qty.
1	100154	HEX PLAIN NUT,5/16-18 SST	2
2	100587	PLUG,1 1/2"NPT SQ.HEAD,B.I.	1
3	100739	CAP SCREW,HEX HEAD,5/16-18 X 3/4 SST	2
4	106013	WASHER,LOCK,5/16 SPLIT,SST	2
5	107340	CLAMP,HOSE,M28,33/57,SST GEAR TYPE	2
6	107342	DRAIN BASKET ASSY,DUO B02-050	1
7	107473	DRAIN TAILPIECE RINSE	1
8	109184	NIPPLE,TOE,1 1/4"NPT X 4" LG.,GALV	1
9	109189	NIPPLE,TOE,1 1/2"NPT X 36" LG.,GALV	1
10	111245	COUPLING RED 2"NPT X 1 1/2"NPT,GALV	1
11	114216	TEE,1 1/2"NPT X 1 1/2"NPT X 1 1/4"NPT,GALV	1
12	114217	NIPPLE,TOE,2"NPT X 8" LG.,GALV	1
13	114219	HOSE,1.625 ID X 9.000 LG.EPDM	1
14	206668	ANGLE,ELECTRIC BOOSTER SUPPORT EUCCW	1
---	206689	ANGLE,ELECTRIC BOOSTER SUPPORT EUCC	1
15	310259	BRACKET, DRAIN LINE SUPPORT,UC'S	2

Drain Installation B4 Prewash RL

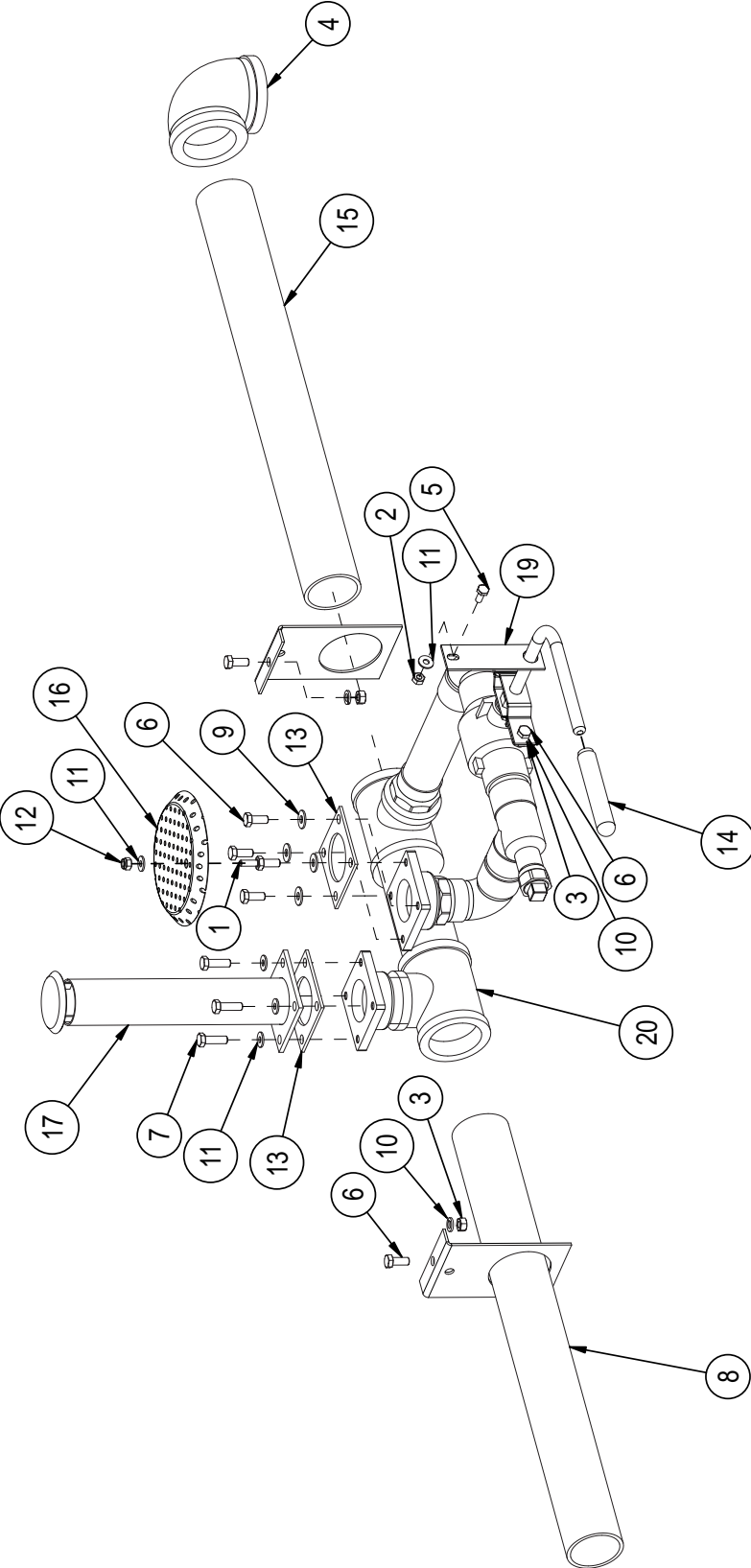



Item No.	Part No.	Description	Qty.
1	100110	WELD-STUD,1/4-20 X 3/4 LG.SST	1
2	100141	HEX GRIP NUT,1/4-20 SST,CTR LOCK	1
3	100154	HEX PLAIN NUT,5/16-18 SST	2
4	100161	ELBOW,2"NPT X 90,GALVANIZED	1
5	100735	HEX HEAD,1/4-20 X 5/8 SST	1
6	100739	HEX HEAD,5/16-18 X 3/4 SST	6
7	100740	HEX HEAD,5/16-18 X 1 SST	4
8	101956	NIPPLE,TOE,2"NPT X 21 3/4" LG.,GALV	1
9	102376	WASHER,FLAT,5/16 x 3/4 x .06 SST	4
10	106013	WASHER,LOCK,5/16 SPLIT,SST	2
11	106026	WASHER,FLAT,1/4x5/8x.06 SST	6
12	107967	HEX GRIP NUT,1/4-20 SST W/NYLON	1
13	108345	GASKET,HEATER/STANDPIPE	2
14	114185	GRIP,DRAIN HANDLE	1
15	114253	NIPPLE,2"NPT X 20 1/2" LG.,GALV	1
16	304816	STRAINER,DRAIN	1
17	305840	OVERFLOW WELDMENT, 9.50 UC	1
18	310259	BRACKET, DRAIN LINE SUPPORT,UC'S	2
19	329677	SUPPORT BRACKET,DRAIN HANDLE	1
20	601819	DRAIN SUB-ASSY,PW,2" TRUNK EUCCW	1
---	601838	DRAIN SUB-ASSY,PW,2" TRUNK EUCC	1

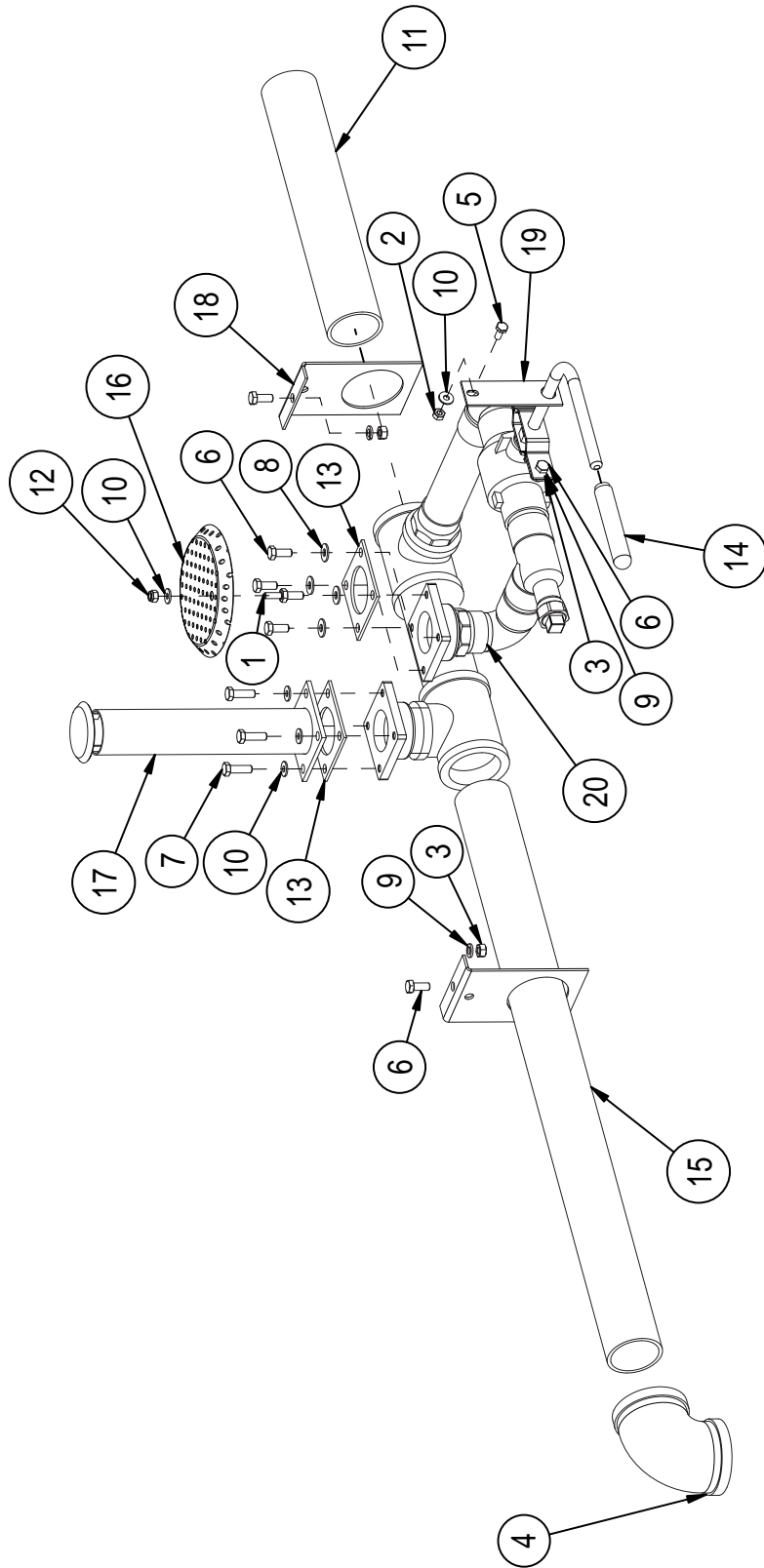

Item No.	Part No.	Description	Qty.
1	100110	WELD-STUD,1/4-20 X 3/4 LG.SST	1
2	100141	HEX GRIP NUT,1/4-20 SST,CTR LOCK	1
3	100154	HEX PLAIN NUT,5/16-18 SST	2
4	100161	ELBOW,2"NPT X 90,GALVANIZED	1
5	100735	HEX HEAD,1/4-20 X 5/8 SST	1
6	100739	HEX HEAD,5/16-18 X 3/4 SST	6
7	100740	HEX HEAD,5/16-18 X 1 SST	4
8	102376	WASHER,FLAT,5/16x3/4x.06 SST	4
9	106013	WASHER,LOCK,5/16 SPLIT,SST	2
10	106026	WASHER,FLAT,1/4x5/8x.06 SST	6
11	106631	NIPPLE,TOE,2"NPT X 12 3/4" LG.,GALV	1
12	107967	HEX GRIP NUT,1/4-20 SST W/NYLON	1
13	108345	GASKET,HEATER/STANDPIPE	2
14	114185	GRIP,DRAIN HANDLE	1
15	114252	NIPPLE,2"NPT X 29 1/2" LG.,GALV	1
16	304816	STRAINER,DRAIN	1
17	305840	OVERFLOW WELDMENT, 9.50 UC	1
18	310259	BRACKET, DRAIN LINE SUPPORT,UC'S	2
19	329677	SUPPORT BRACKET,DRAIN HANDLE	1
20	601819	DRAIN SUB-ASSY,PW,2" TRUNK EUCCW	1
---	601838	DRAIN SUB-ASSY,PW,2" TRUNK EUCC	1

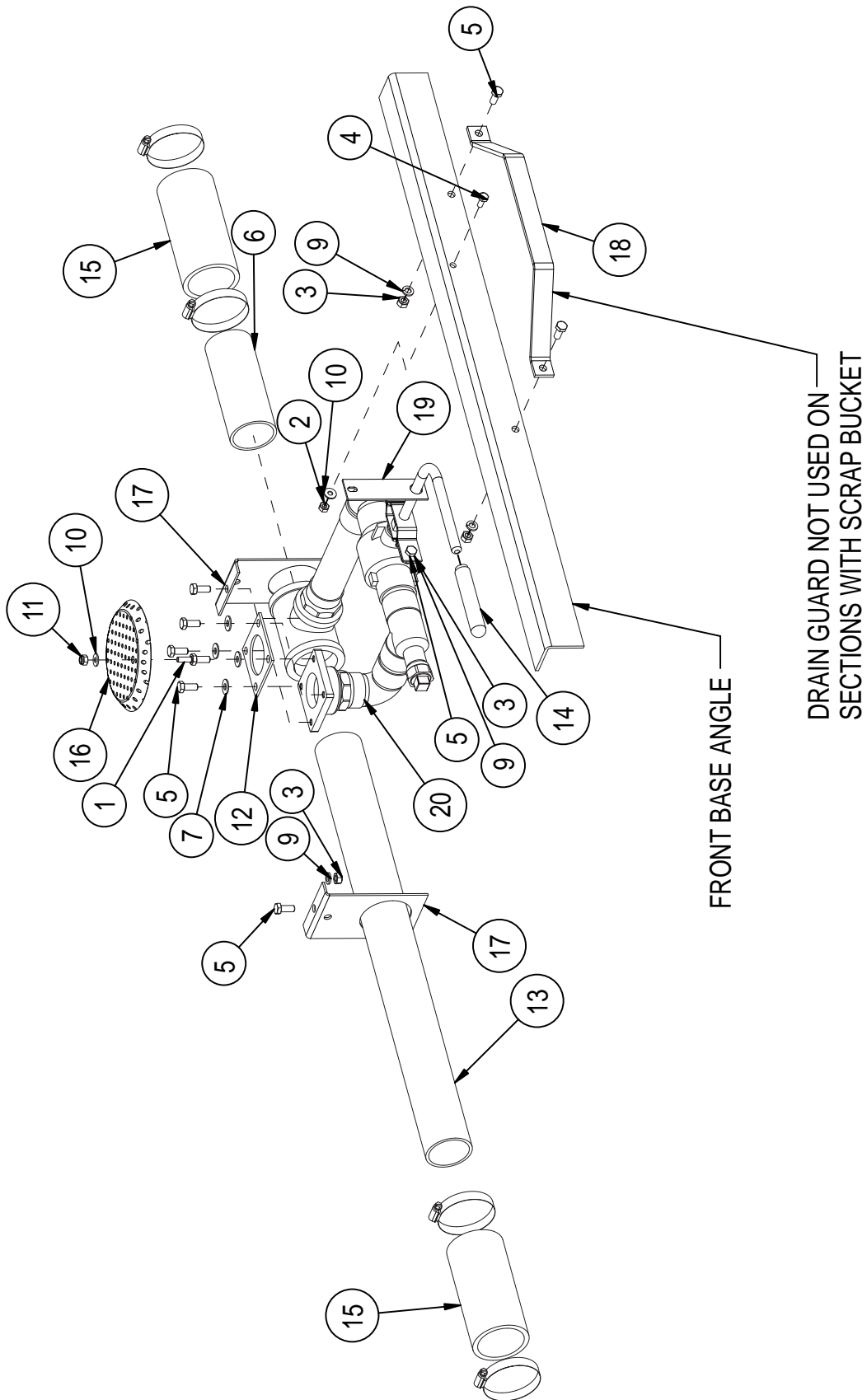

Item No.	Part No.	Description	Qty.
1	100110	WELD-STUD,1/4-20 X 3/4 LG.SST	1
2	100141	HEX GRIP NUT,1/4-20 SST,CTR LOCK	1
3	100154	HEX PLAIN NUT,5/16-18 SST	4
4	100735	HEX HEAD,1/4-20 X 5/8 SST	1
5	100739	HEX HEAD,5/16-18 X 3/4 SST	8
6	101920	NIPPLE,TOE,2"NPT X 5 3/4" LG.,GALV	1
7	102376	WASHER,FLAT,5/16 x 3/4 x .06 SST	4
8	104165	CLAMP,HOSE,M40,52/76,SST GEAR TYPE	4
9	106013	WASHER,LOCK,5/16 SPLIT,SST	4
10	106026	WASHER,FLAT,1/4 x 5/8 x .06 SST	2
11	107967	HEX GRIP NUT,1/4-20 SST W/NYLON	1
12	108345	GASKET,HEATER/STANDPIPE	1
13	114176	NIPPLE,TOE,2"NPT X 25 1/2" LG.,GALV	1
14	114185	GRIP,DRAIN HANDLE	1
15	202073	HOSE,2.375 ID X 6.000 LG.EPDM	2
16	304816	STRAINER,DRAIN	1
17	310259	BRACKET, DRAIN LINE SUPPORT,UC'S	2
18	329130	GUARD, DRAIN VALVE	1
19	329677	SUPPORT BRACKET,DRAIN HANDLE	1
20	601820	DRAIN SUB-ASSY,W/R,2" TRUNK EUCCW	1
---	601839	DRAIN SUB-ASSY,W/R,2" TRUNK EUCC	1

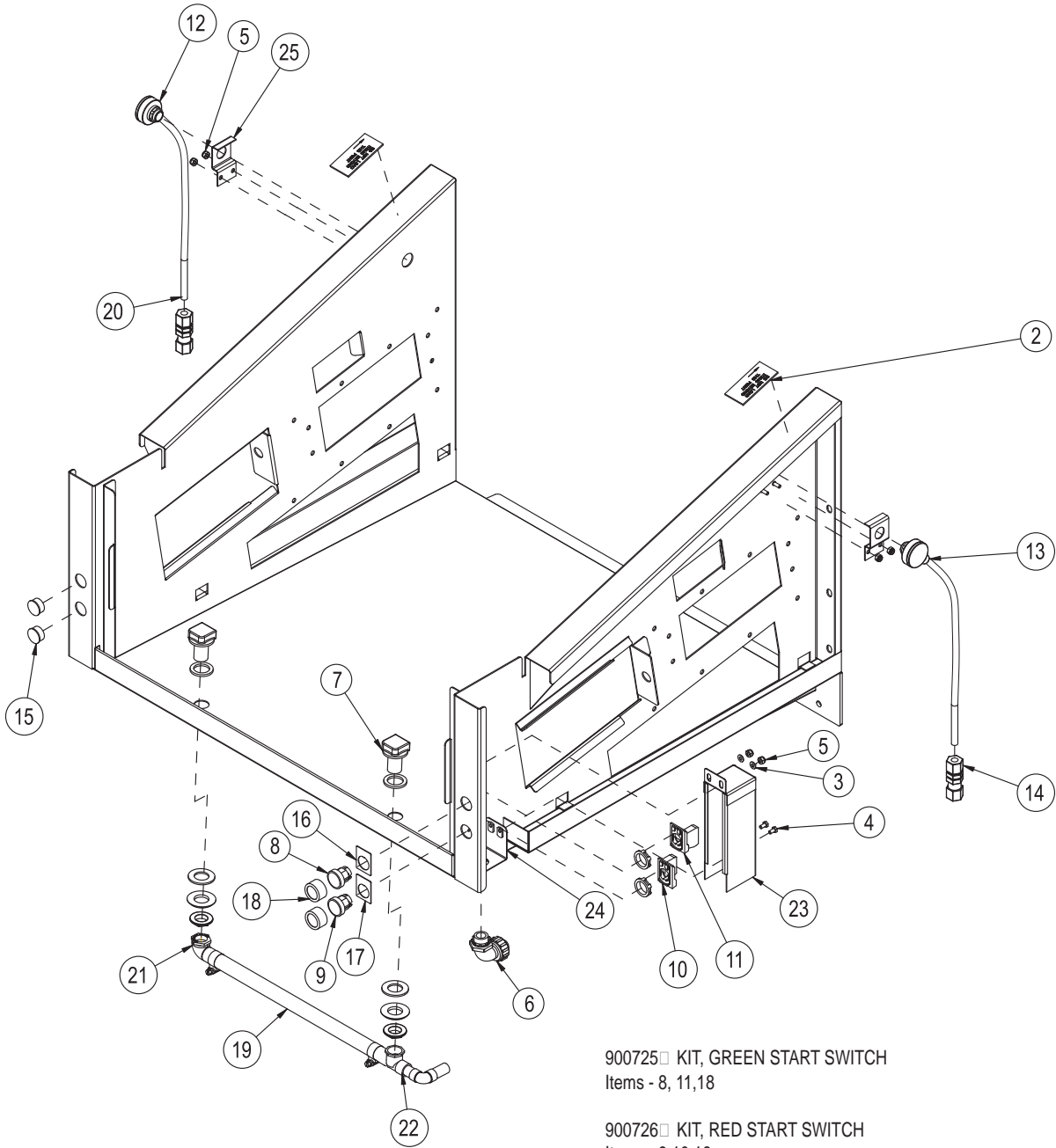

Electric Eyes, Start-Stop Station, Flushing Nozzles

Item No.	Part No.	Description	Qty.
1	105994	CLAMP,HOSE,M10,14/27,SST GEAR TYPE	2
2	107003	LOAD PLACARD ELEC EYE	2
3	107033	WASHER,FLAT,.208X.438X.047 SST	4
4	107136	SCREW,HEX HEAD,10-32 x 3/8 SST	2
5	107966	HEX GRIP NUT,10-32 SST W/NYLON	8
6	110837	ELBOW,1/2" CONDUIT,SEALTITE	1
7	111325	NOZZLE FLUSH-N POLISHED CHROME	2
8	111614	PUSHBUTTON ASSY,GREEN 22MM	1
9	111615	PUSHBUTTON ASSY,RED 22MM	1
10	111616	CONTACT BLOCK,NC,START/STOP	1
11	111617	CONTACT BLOCK,NO,START/STOP	1
12	112241	ELECTRIC EYE EMITTER,UC MACHINE	1
13	112242	ELECTRIC EYE RECIEVER,UC MACHINE	1
14	112245	UNION BULKHEAD 3/8 od PLASTIC	2
15	112519	PLUG SNAP 0.875 D-FLAT #2509HE	2
16	112822	NAMEPLATE,START	1
17	112823	NAMEPLATE,STOP	1
18	113140	BOOT,PUSHBUTTON,22MM	2
19	205193	HOSE,5/8ID X 15 /14"LG,CLEAR	1
20	205907	TUBE,3/8 OD X 19 LG.POLYPROPYL	2
21	309709	ELBOW WELD-FLUSHING SYS,UC	1
22	309711	TEE & ELBOW WELD,FLUSHING SYSTEM	1
23	330022	COVER WELD,START/STOP SWITCH,EUC	1
24	330024	BRACKET WELD START/STOP,EUC	1
25	330120	BRACKET ELECTRIC EYE MOUNTING	2

Idle Shaft Assembly

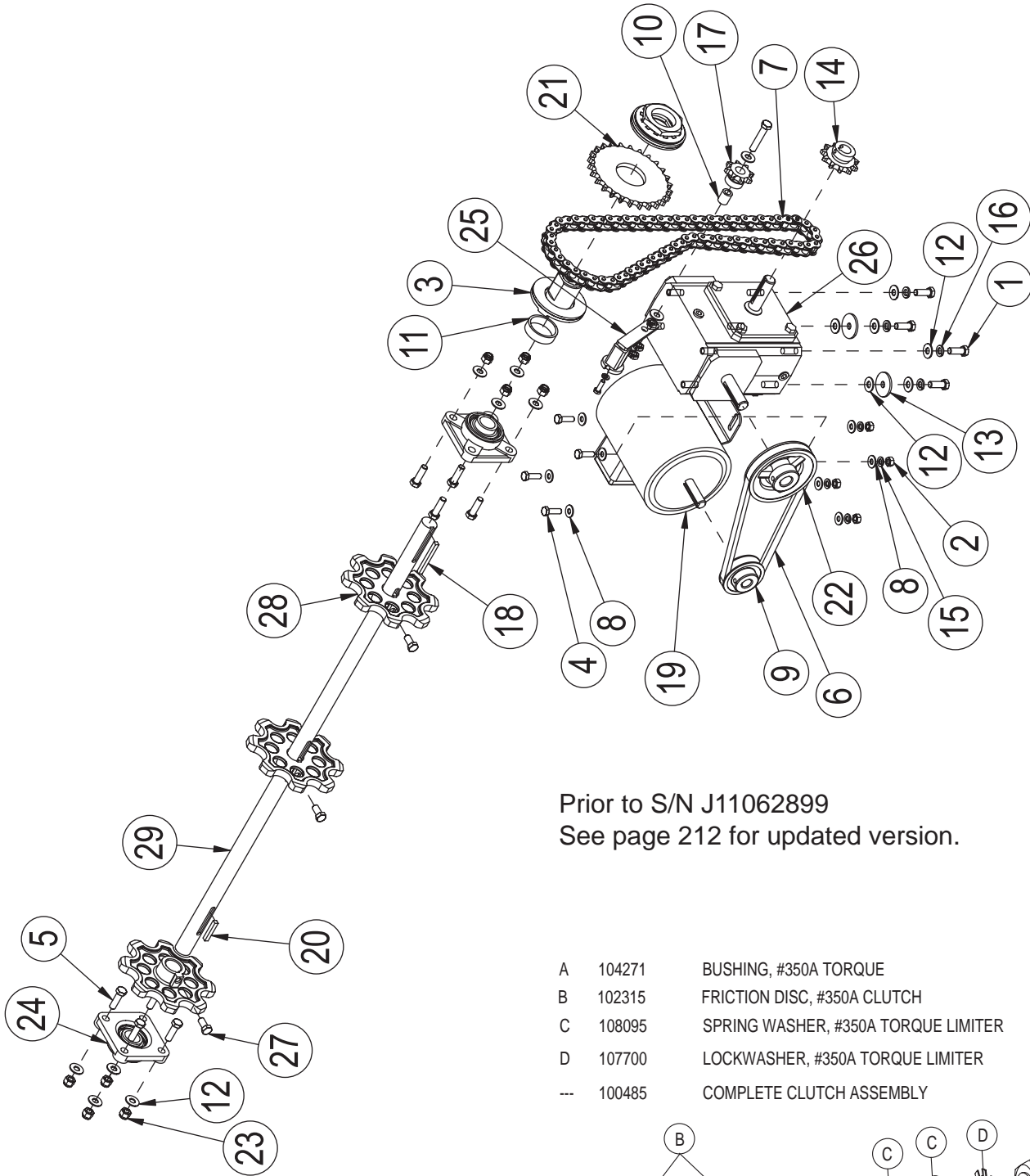

Prior to S/N J11062899  
See page 212 for updated version.

A	104271	BUSHING, #350A TORQUE	1
B	102315	FRICION DISC, #350A CLUTCH	2
C	108095	SPRING WASHER, #350A TORQUE LIMITER	2
D	107700	LOCKWASHER, #350A TORQUE LIMITER	1
--	100485	COMPLETE CLUTCH ASSEMBLY	1

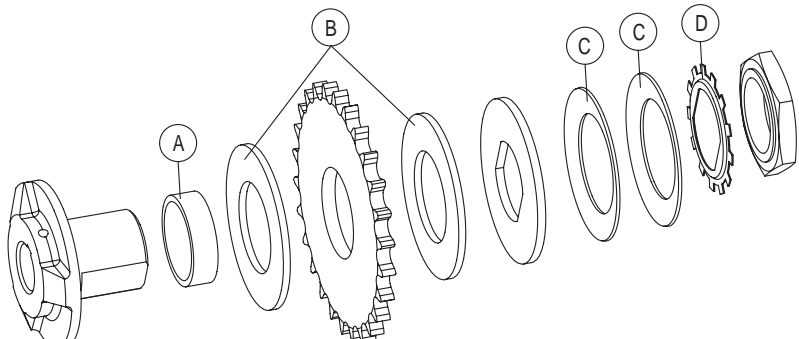



Item No.	Part No.	Description	Qty.
1	100153	HEX HEAD,3/8-16 X 1 SST	4
2	100154	HEX PLAIN NUT,5/16-18 SST	4
3	100485	TORQUE LIMITER ASSY,#350 A-2	1
4	100740	HEX HEAD,5/16-18 X 1 SST	4
5	100746	HEX HEAD,3/8-16 X 1 1/4 SST	8
6	100794	V-BELT,4L-310	1
7	101156	CHAIN LINK,#50,INNER	36
8	102376	WASHER,FLAT,5/16x3/4x.06 SST	8
9	103163	SHEAVE,AK27,5/8 BORE	1
10	104265	BUSHING,3/8x5/8x3/4 LG.BRONZE	1
11	104271	BUSHING,TORQUE LIMITER,,54LG. #350TL	1
12	104618	WASHER,FLAT,3/8x7/8x.06 SST	16
13	104619	WASHER,FLAT,3/8x1 1/2x1/8 SST	2
14	105285	SPROCKET,50B11,3/4 BORE, W/KEY	1
15	106013	WASHER,LOCK,5/16 SPLIT,SST	4
16	106407	WASHER,LOCK,3/8 SPLIT,SST	4
17	106521	SPROCKET,50B8,5/8 BORE	1
18	106679	KEY,1/4 X 1/4 X 2 1/2" LG.SST	1
19	107183	MOTOR, 1/2HP UC/CC DRIVE,MV 3PH	1
20	107305	KEY 1/4 X 1/4 X 1 1/2 SST	3
21	108013	SPROCKET, TORQUE LIMITER,350AG26	1
22	108088	SHEAVE,AK46,3/4 BORE	1
23	109010	HEX GRIP NUT,3/8-16 SST W/NYLON	8
24	109958	BEARING,4 BOLT,1",UC DRIVE	2
25	110076	TENSIONAR ASSY,LOVEJOY	1
26	110300	GEAR REDUCER,60:1,NO BRACKETS	1
27	111480	HEX HEAD,3/8-16 X 3/4 SS T,W/LOCTITE	3
28	113970	SPROCKET,UC CONVEYOR DRIVE	3
29	330011	SHAFT, DRIVE, EUCCW	1
30	408718	TENSIONER ASSY,UC MACHINE	1

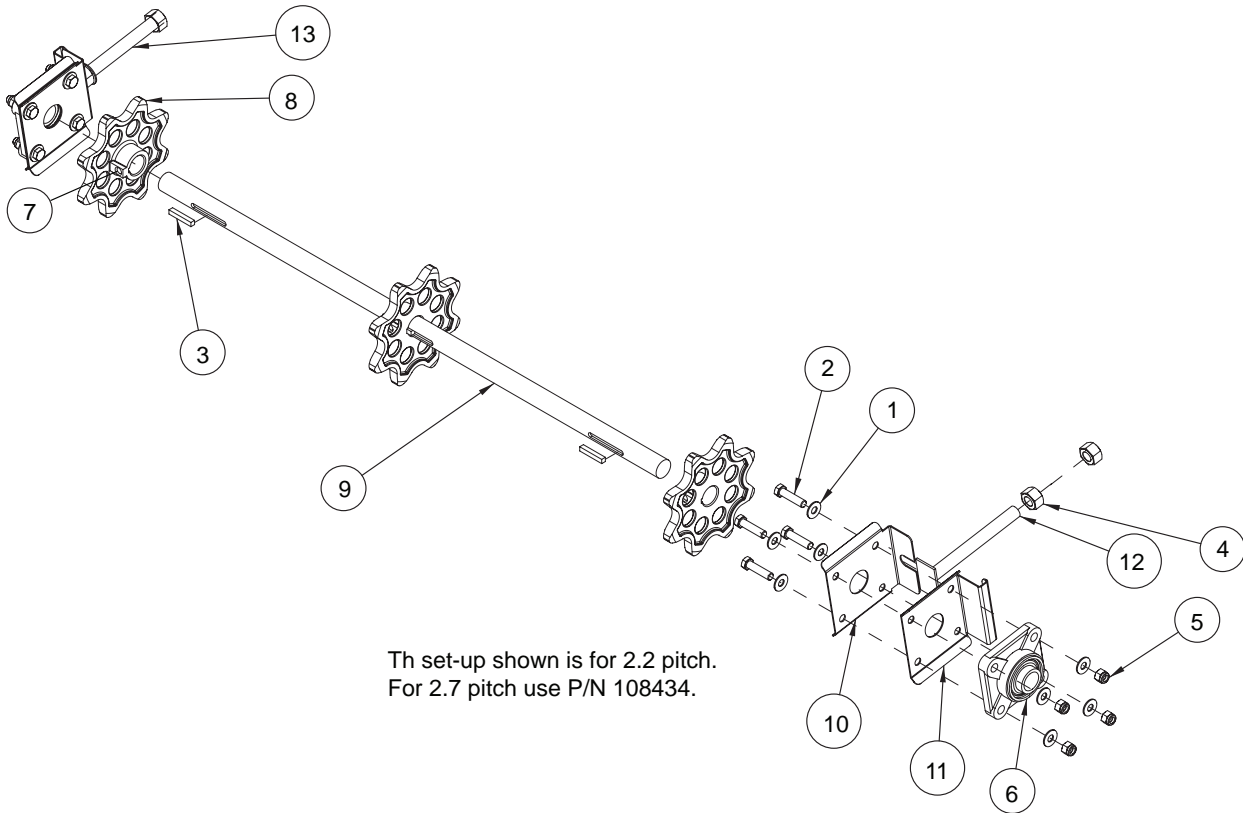

This set-up shown is for 2.2 pitch.  
For 2.7 pitch use P/N 108434.

Item No.	Part No.	Description	Qty.
1	104618	WASHER,FLAT,3/8x7/8x.06 SST	16
2	106022	CAP SCREW,HEX HEAD,3/8-16 X 1 1/2 SST	8
3	107305	KEY 1/4 X 1/4 X 1 1/2 SST	3
4	107691	HEX PLAIN NUT,5/8-11 SST	4
5	109010	HEX GRIP NUT,3/8-16 SST W/NYLON	8
6	109958	BEARING,4 BOLT,1",UC DRIVE	2
7	111480	CAP SCREW,HEX HEAD,3/8-16 X 3/4 SST,W/LOCTITE	3
8	113970	SPROCKET,UC CONVEYOR DRIVE	3
9	206604	SHAFT,IDLE,EUCCW	1
10	330113	BRACKET,BEARING,PART 1	2
11	330114	BRACKET,BEARING,PART 2	2
12	330115	SCREW WELDMENT,TAKE-UP	2
13	416422	SCREW ASSY,TAKE-UP	2

E-UCCW Peg Belt

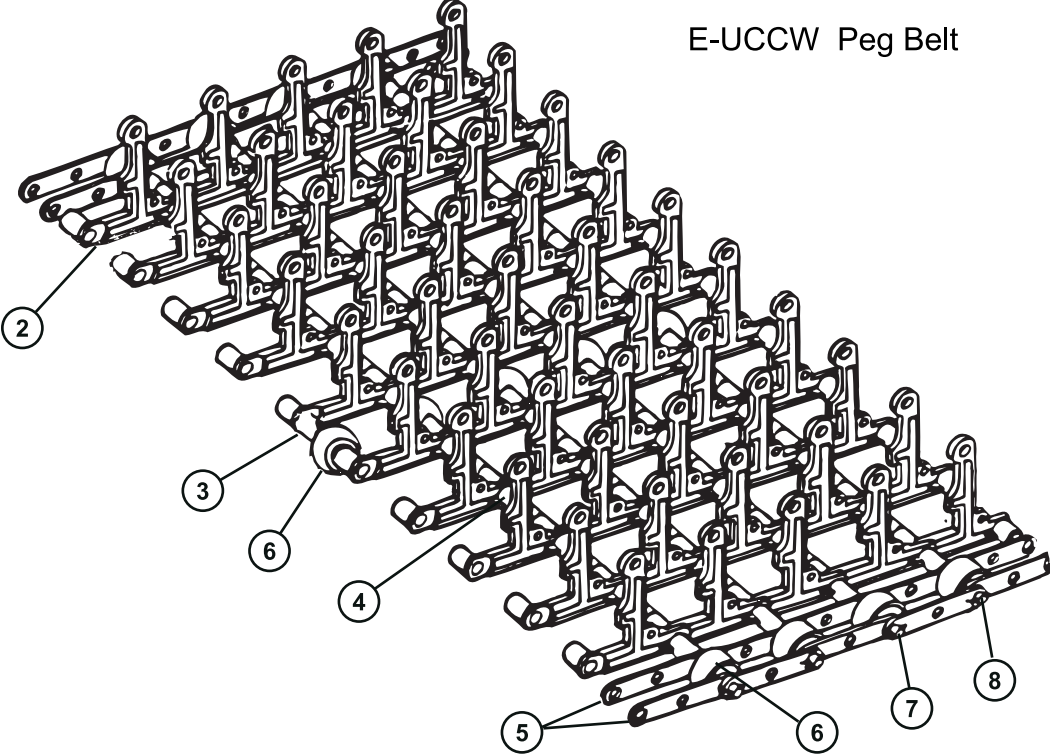

E-UCCW Belt w/Upper rod

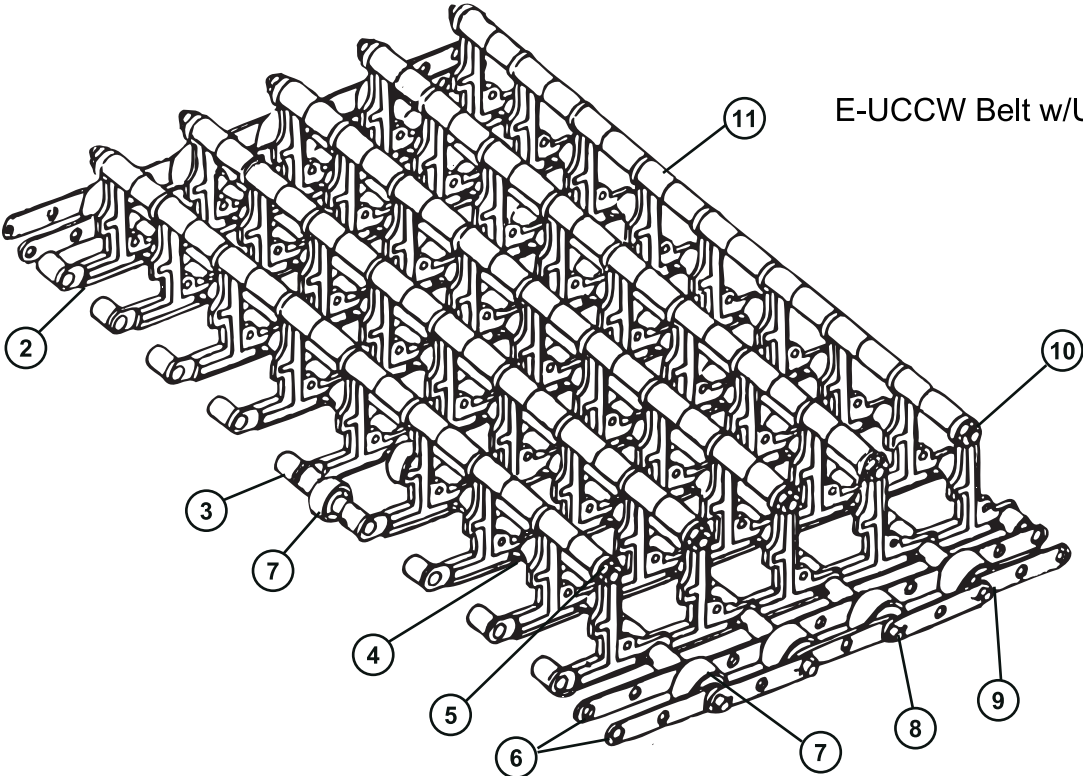

Item No.	Part No.	Description	Qty.
1	404104	Rod Section, Peg Belt,	A/R
2	110092	Link, Upright	10
3	108378	Spacer (11/32 x 5/16)	2
4	108438	Spacer (11/32 x 1-13/32)	8
5	108435	Link, Straight End, Stainless Steel	4
6	114536	Roller, Plastic	3
7	108875	Pin, Cotter	2
8	108381	Rod, Drilled Stainless Steel (5/16 x 29-1/4)	1

Item No.	Part No.	Description	Qty.
1	404106	Rod Section, Peg Belt w/ Upper Rod,	A/R
2	110092	Link, Upright.	10
3	108378	Spacer (11/32 x 5/16)	2
4	108438	Spacer (11/32 x 1-13/32)	8
5	100141	Nut, Grip (1/4-20 SST)	2
6	108435	Link, Straight End, Stainless Steel	4
7	114536	Roller, Plastic	3
8	108875	Pin, Cotter	2
9	108381	Rod, Drilled Stainless Steel (5/16 x 29-1/4)	1
10	202601	Rod, Threaded Stainless Steel (1/4 x 26)	1
11	108439	Spacer (1/2 x 9/32 x 2-9/16)	9

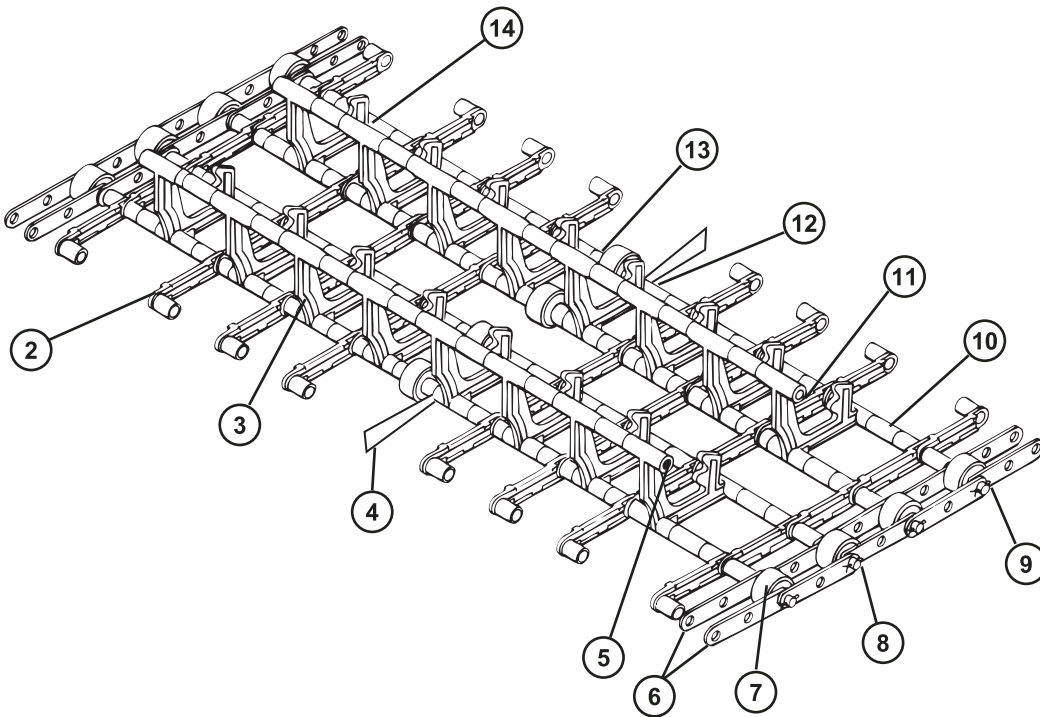
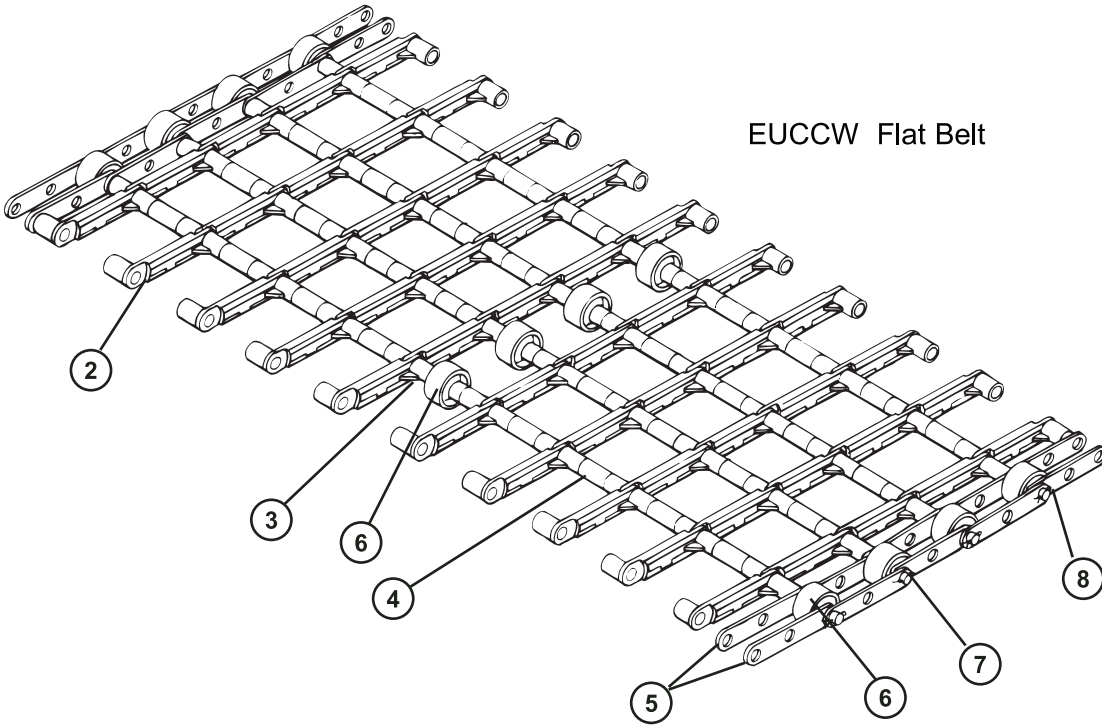

Item No.	Part No.	Description	Qty.
1	402237	TWO Rod Sections, Flat Belt	A/R
2	110094	Link, Flat	20
3	108378	Spacer (11/32 x 5/16)	6
4	108438	Spacer (11/32 x 1-13/32)	16
5	108435	Link, Straight End, Stainless Steel	8
6	114536	Roller, Plastic	6
7	108875	Pin, Cotter	4
8	108381	Rod, Drilled Stainless Steel (5/16 x 29-1/4)	2

Item No.	Part No.	Description	Qty.
1	402238	TWO Rod Sections	A/R
2	110094	Link, Flat	16
3	109030	Link, Upright Poly	8
4	204995	Link, Flat Modified	1
5	100141	Nut, Grip (1/4-20 SST)	2
6	108435	Link, Straight End, Stainless Steel	8
7	114536	Roller, Plastic	6
8	108875	Pin, Cotter	4
9	108381	Rod, Drilled Stainless Steel (5/16 x 29-1/4)	2
10	109282	Spacer (11/32 x 1-1/32)	4
11	109224	Rod, Threaded Stainless Steel (1/4 x 22-1/4)	1
12	102376	Washer (5/16 x 3/4 x 1/16)	2
13	108378	Spacer (11/32 x 5/16)	2
14	109187	Spacer (9/32 x 1-13/32)	7

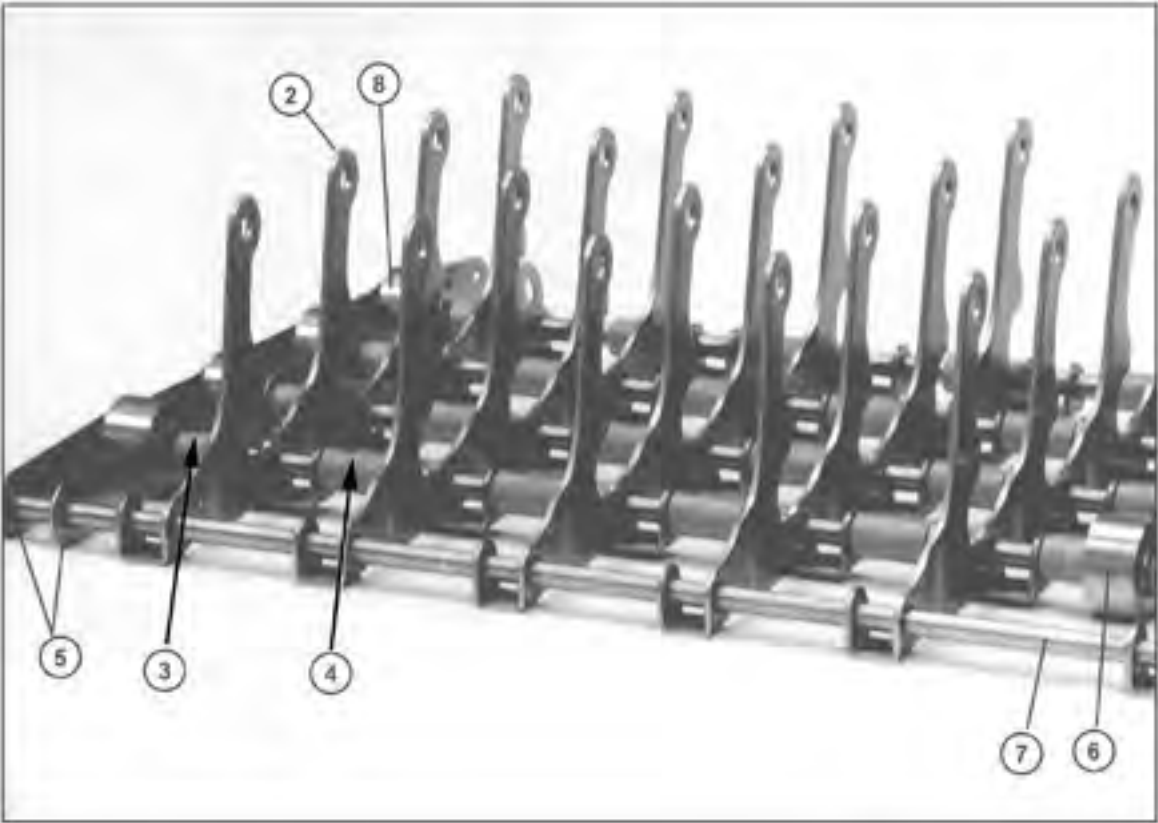



Item No.	Part No.	Description	Qty.
1	408013	Rod Section, Stainless Steel peg belt	A/R
2	111421	Link, Stainless Steel Upright	10
3	109282	Spacer (11/32 x 1-1/32)	8
4	108378	Spacer (11/32 x 5/16)	8
5	108435	Link, Straight End, Stainless Steel	4
6	108375	Roller, Stainless Steel	3
7	108381	Rod, Drilled Stainless Steel (5/16 x 29-1/4)	1
8	108875	Pin, Cotter (Not Shown)	2
EUCCW Stainless Steel Peg Belt with Upper Rod contains Items 2-8 and the Parts Listed Below			
—	100141	Nut, Grip (1/4-20 SST) (Not Shown)	2
—	202601	Rod, Threaded (1/4 x 26) (Not Shown)	1

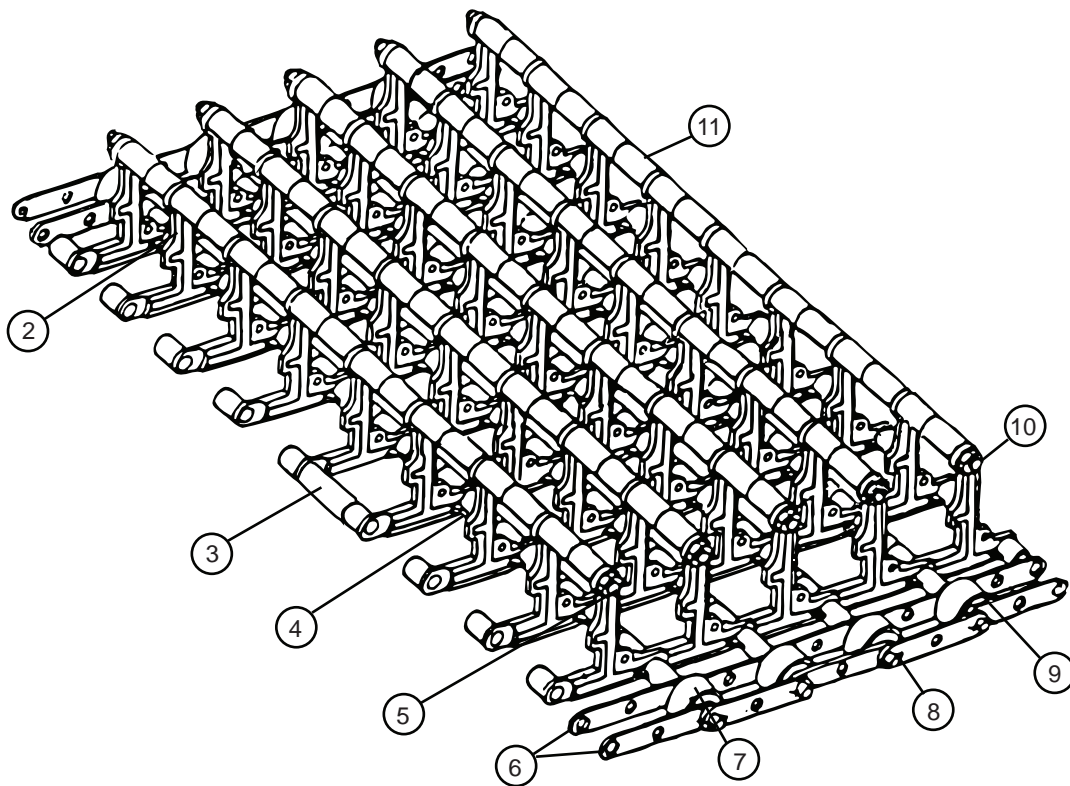
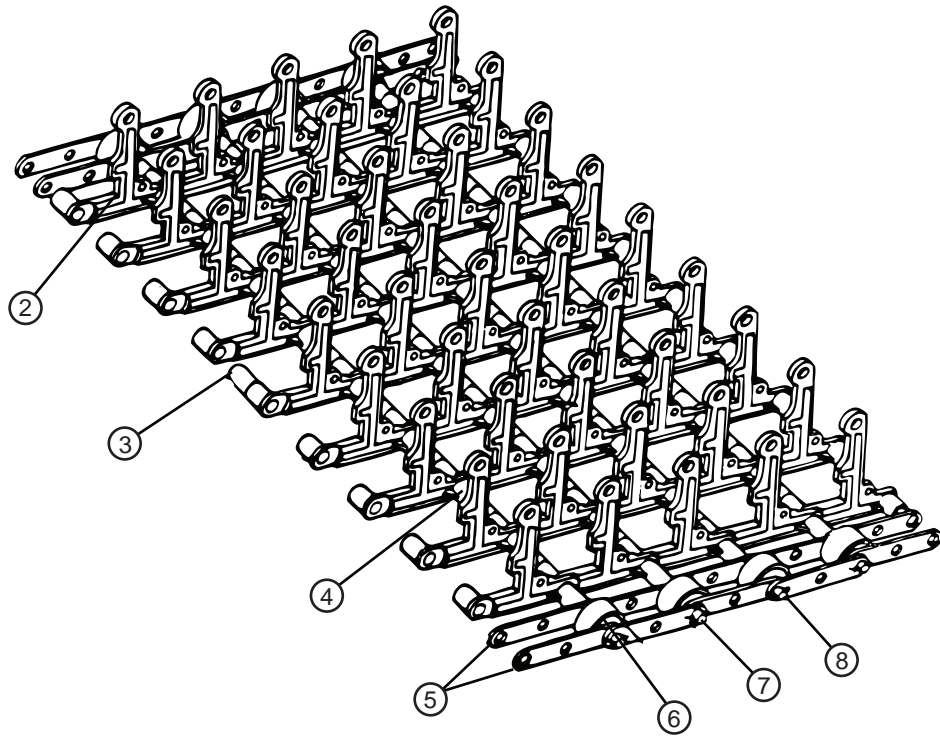

Item No.	Part No.	Description	Qty.
1	404105	Rod Section, Peg Belt	A/R
2	110092	Link, Upright	9
3	108378	Spacer, 11/32" x 5/16"	1
4	108377	Spacer, 11/32" x 1-3/32"	8
5	108435	Link, Straight End, SST	4
6	114536	Roller, Plastic	2
7	108875	Pin, Cotter	2
8	108380	Rod, Drilled SST 5/16" x 24"	1

Item No.	Part No.	Description	Qty.
1	404114	Rod Section, Peg Belt with Upper Rods	A/R
2	110092	Link, Upright	9
3	108378	Spacer, 11/32" x 5/16"	1
4	108377	Spacer, 11/32" x 1-3/32"	8
5	100141	Grip Nut, 1/4-20 SST	2
6	108435	Link, Straight End, SST	4
7	114536	Roller, Plastic	2
8	108875	Pin, Cotter	2
9	108380	Rod, Drilled SST 5/16" x 24"	1
10	108376	Rod, Threaded SST 1/4" x 20-5/8" SST	1
11	108379	Spacer, 1/2" x 9/32" x 2-1/4"	8

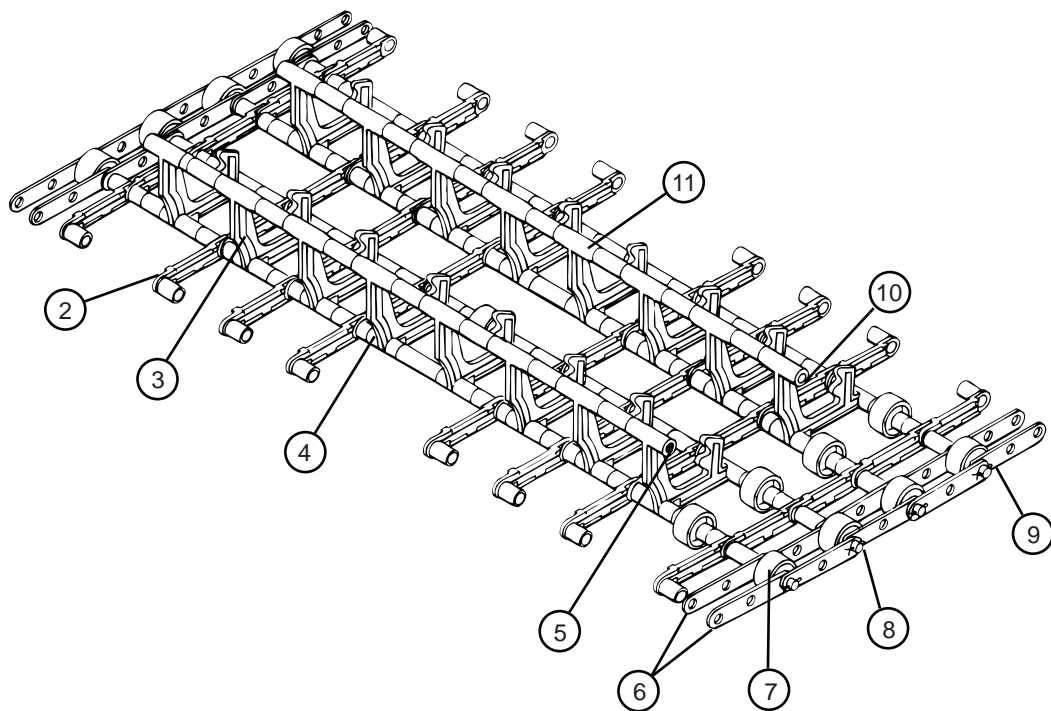
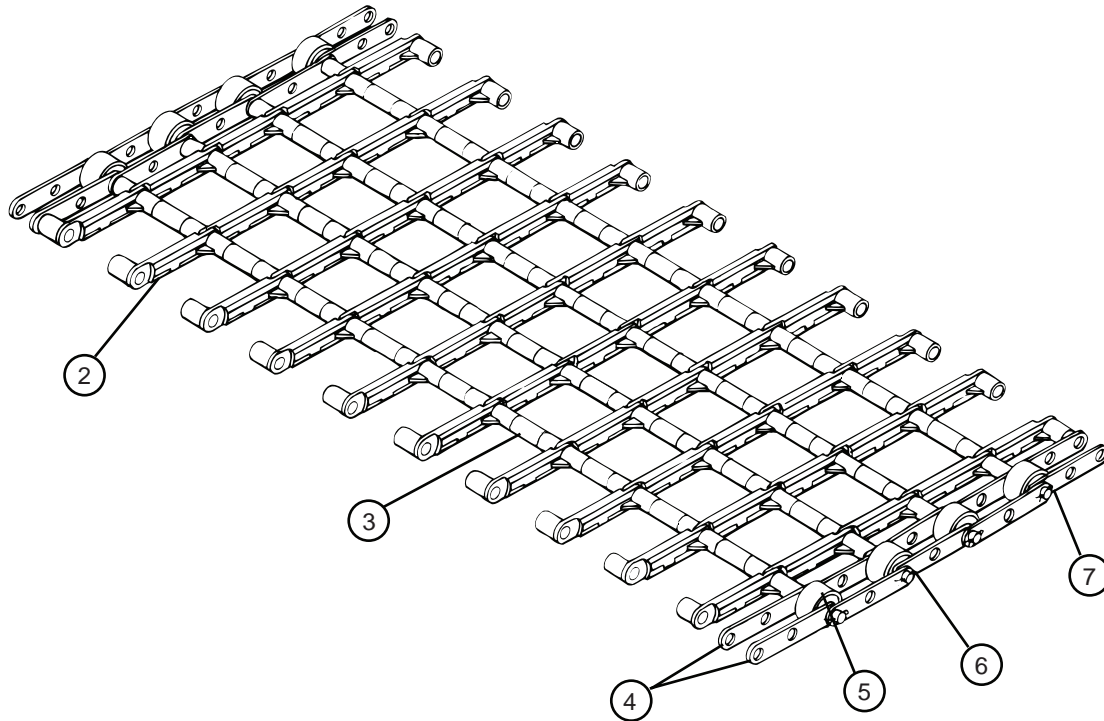

Item No.	Part No.	Description	Qty.
1	402294	Two Rod Section, Flat Belt	A/R
2	110094	Link, Flat	18
3	108377	Spacer, 11/32" x 1-3/32"	16
4	108435	Link, Straight End, SST	8
5	114536	Roller, Plastic	2
6	108875	Pin, Cotter	2
7	108380	Rod, Drilled SST 5/16" x 24"	1

Item No.	Part No.	Description	Qty.
1	402295	Two Rod Sections, Insulated Tray Belt	A/R
2	110094	Link, Flat	12
3	109030	Link, Upright, Poly	8
4	109282	Spacer, 11/32" x 1-1/32"	3
5	100141	Grip Nut, 1/4-20 SST	2
6	108435	Link, Straight End, SST	8
7	114536	Roller, Plastic	4
8	108875	Pin, Cotter	4
9	108380	Rod, Drilled SST 5/16" x 24"	2
10	109225	Rod, Threaded SST 1/4" x 21-3/4" SST	1
11	109187	Spacer, 9/32" x 1-13/16"	6

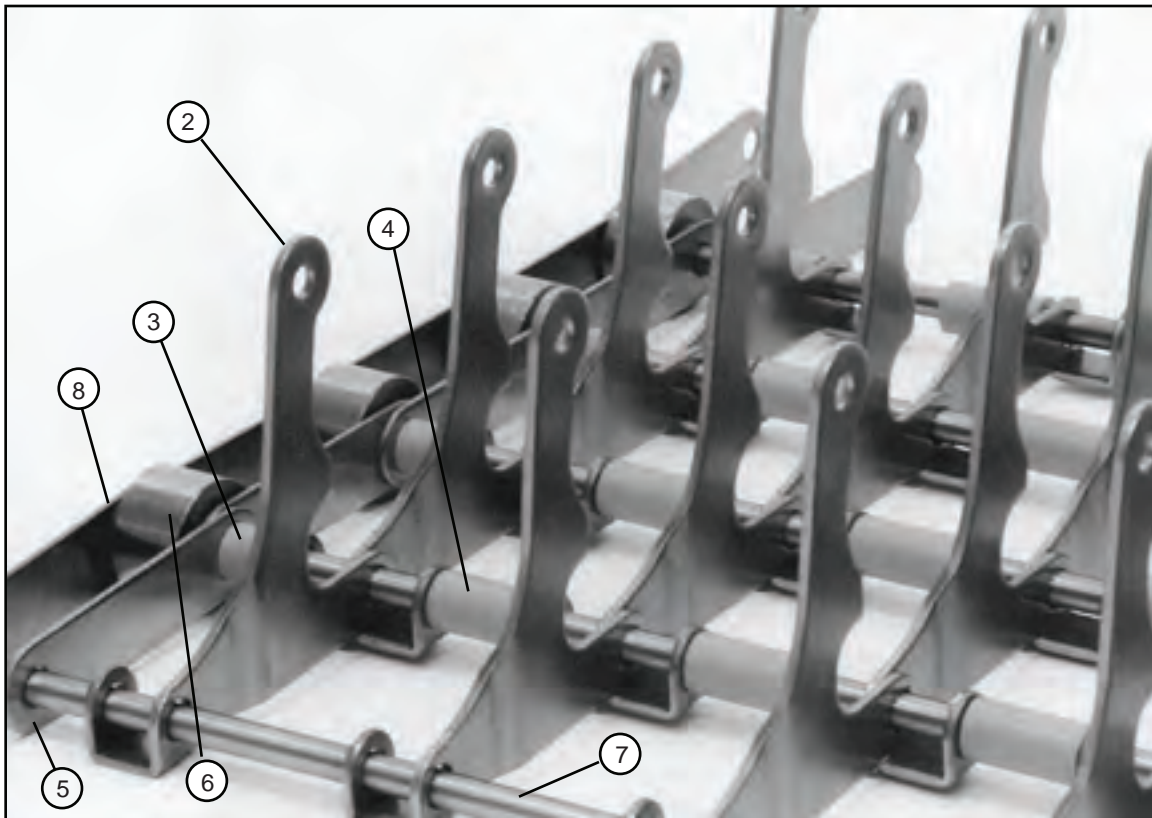

Item No.	Part No.	Description	Qty.
1	-----	Rod Section, SST Peg Belt EUCC	A/R
2	111421	Link, Upright SST	8
3	109282	Spacer, 11/32" x 1-1/32"	7
4	108377	Spacer, 11/32" x 1-3/32"	2
5	108435	Link, Straight End, SST	4
6	108375	Roller, SST	2
7	108380	Rod, Drilled SST 5/16" x 24"	1
8	108875	Pin, Cotter (Not Shown)	2
EUCC Stainless Steel Peg Belt with Upper Rod contains Items 2-8 and the Parts Listed Below			
---	100141	Grip Nut, 1/4-20 SST (Not Shown)	2
---	205067	Rod, Threaded, 1/4" x 18-3/8" (Not Shown)	1
---	105197	Spacer, 11/32" x 2-7/16" (Not Shown)	7

Vent Cowl Installation

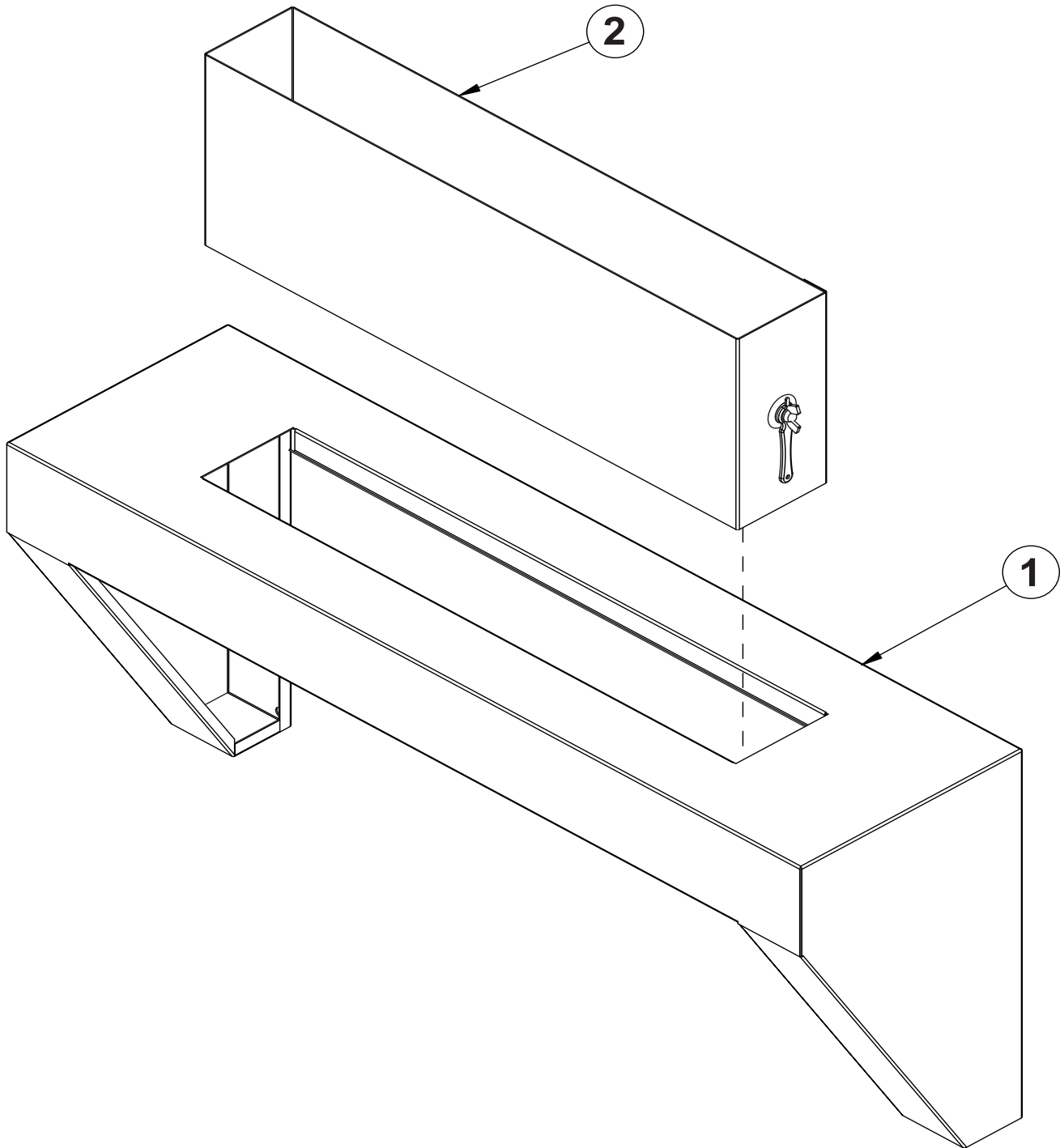



Item No.	Part No.	Description	Qty.
1	329806	VENT COWL WELDMENT, UCW-04	1
2	401486	VENT STACK 4 x 24	1

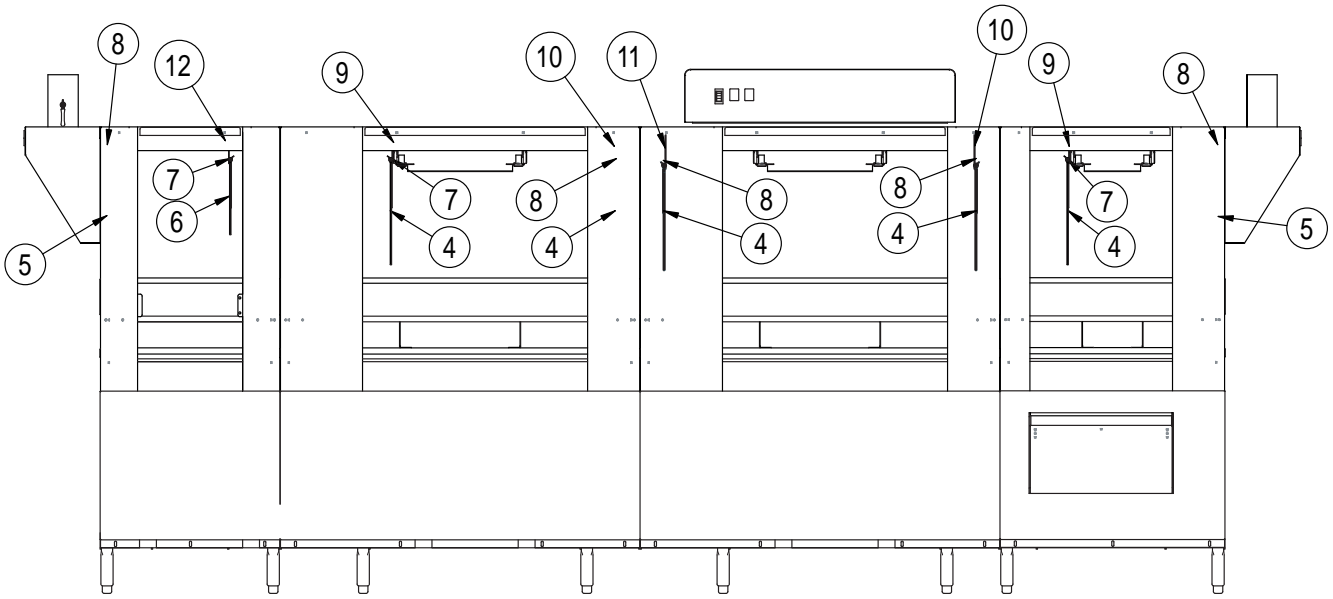

R-L

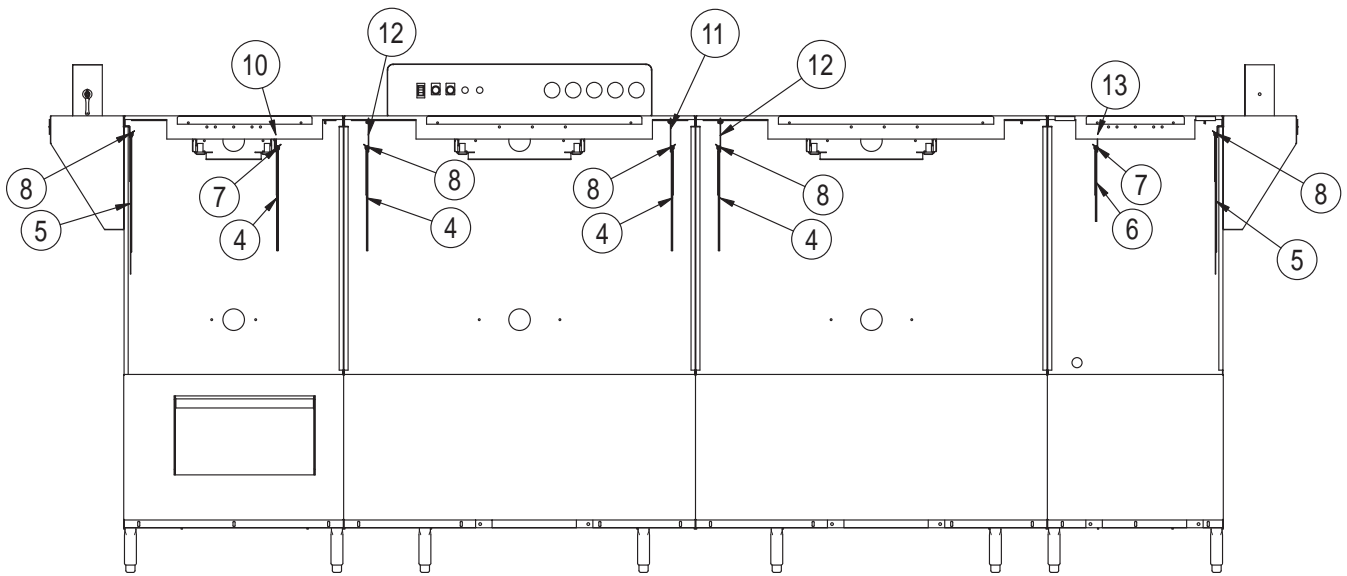

L-R

**R-L**

Item No.	Part No.	Description	Qty.
1	100734	HEX HEAD,1/4-20 X 1/2 SST	12
2	106026	WASHER,FLAT,1/4x5/8x.06 SST	12
3	106482	WASHER,LOCK,1/4 SPLIT,SST	12
4	112445	CURTAIN,SHORT,14 X 32,NUCCW	5
5	114111	CURTAIN,LONG,19 X 34 1/4,EUCCW	2
6	204949	CURTAIN,SHORT,10 X 32,NUCCW AUX-RINSE.	1
7	205432	ROD,CURTAIN,5/16 X 32"LG.SST,UCCW	3
8	206581	ROD,CURTAIN,5/16 X 34 1/4"LG.SST,UCCW	5
9	329719-2	BAFFLE, CURTAIN HANGER.MANIFOLD MTD,LH	2
10	329720-1	BAFFLE, CURTAIN HANGER,HOOD MTD,LH	2
11	329720-2	BAFFLE, CURTAIN HANGER,HOOD MTD,RH	1
12	331200-1	BAFFLE, CURTAIN HANGER,AUX. CENTER, R-L	1

**L-R**

Item No.	Part No.	Description	Qty.
1	100734	HEX HEAD,1/4-20 X 1/2 SST	10
2	106026	WASHER,FLAT,1/4x5/8x.06 SST	10
3	106482	WASHER,LOCK,1/4 SPLIT,SST	10
4	112445	CURTAIN,SHORT,14 X 32,NUCCW	4
5	114111	CURTAIN,LONG,19 X 34 1/4,EUCCW	2
6	204949	CURTAIN,SHORT,10 X 32,NUCCW AUX.-RINSE	1
7	205432	ROD,CURTAIN,5/16 X 32"LG.SST,UCCW	2
8	206581	ROD,CURTAIN,5/16 X 34 1/4"LG.SST,UCCW	5
9	329088	HOOD WELDMENT,C4R-B,ELEC/STEAM	1
10	329719-1	BAFFLE, CURTAIN HANGER.MANIFOLD MTD,RH	1
11	329720-1	BAFFLE, CURTAIN HANGER,HOOD MTD,LH	1
12	329720-2	BAFFLE, CURTAIN HANGER,HOOD MTD,RH	2
13	331200-2	BAFFLE, CURTAIN HANGER,AUX. RINSE CENTER, L-R	1

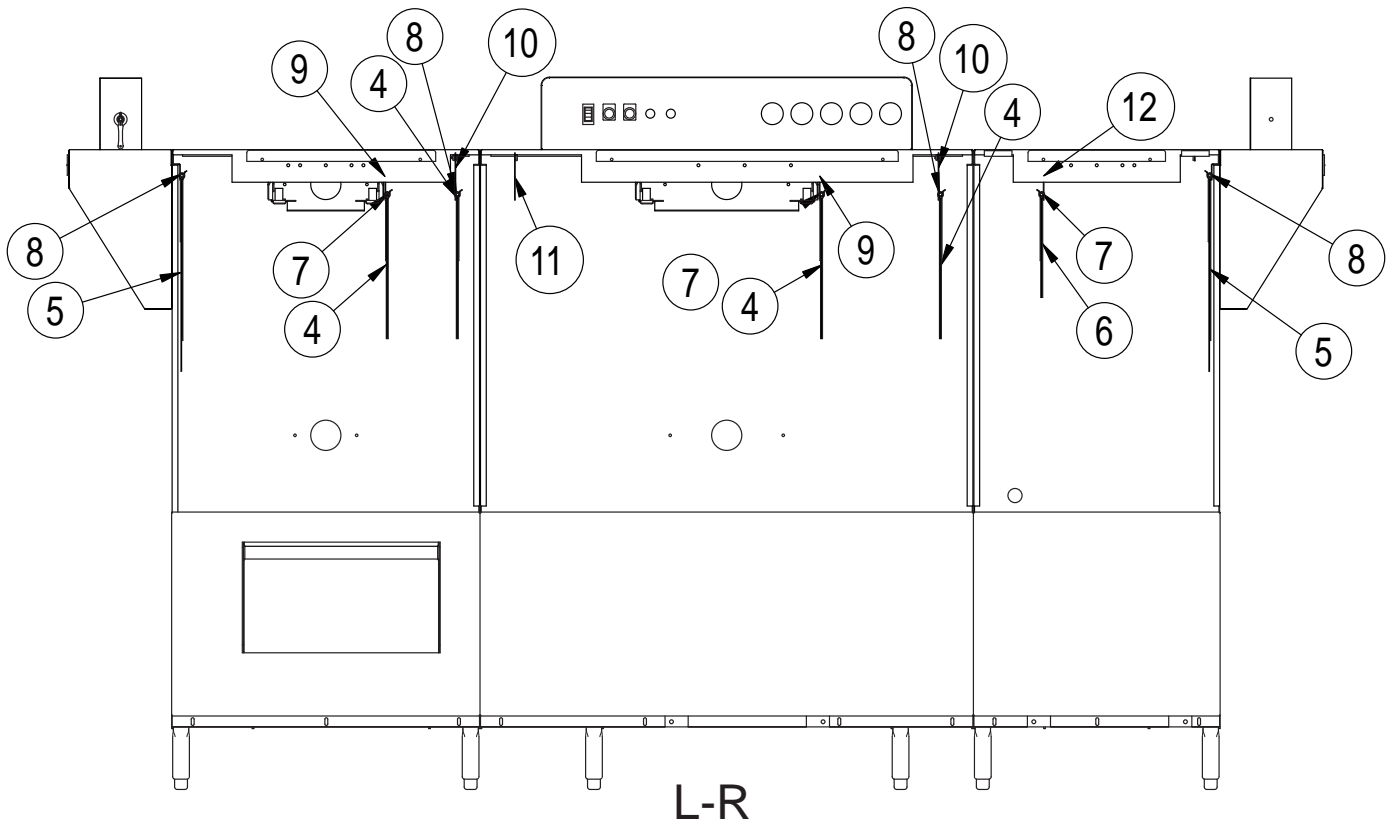
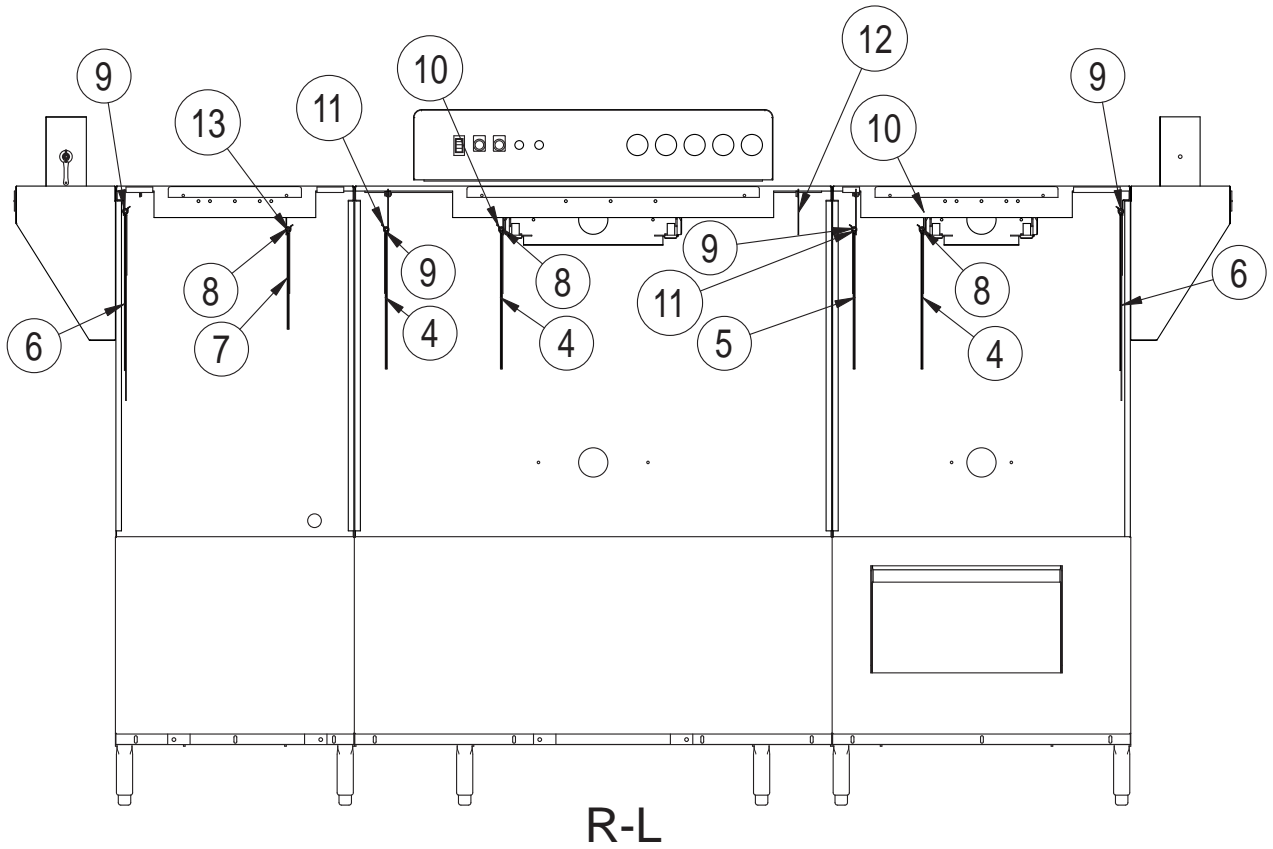

**R-L**

Item No.	Part No.	Description	Qty.
1	100734	HEX HEAD,1/4-20 X 1/2 SST	10
2	106026	WASHER,FLAT,1/4x5/8x.06 SST	10
3	106482	WASHER,LOCK,1/4 SPLIT,SST	10
4	112445	CURTAIN, DISHWASHER,UC MACHINE	3
5	114110	CURTAIN, DISHWASHER,UC MACHINE	1
6	114111	CURTAIN, DISHWASHER,UC MACHINE	2
7	204949	CURTAIN, DISHWASHER,UC MACHINE	1
8	205432	ROD,CURTAIN,5/16 X 32"LG.SST,UCCW	3
9	206581	ROD,CURTAIN,5/16 X 34 1/4"LG.SST,UCCW	4
10	329719-2	BAFFLE, CURTAIN HANGER.MANIFOLD MTD,LH	2
11	329720-2	BAFFLE, CURTAIN HANGER,HOOD MTD,RH	2
12	330497	BAFFLE, CURTAIN ,BLANK,HOOD MTD	1
13	331200-1	BAFFLE, CURTAIN HANGER,AUX. RINSE CENTER,R-L	1

**L-R**

Item No.	Part No.	Description	Qty.
1	100734	HEX HEAD, 1/4-20 X 1/2 SST	10
2	106026	WASHER,FLAT,1/4x5/8x.06 SST	10
3	106482	WASHER,LOCK,1/4 SPLIT,SST	10
4	112445	CURTAIN,SHORT,14 X 32,NUCCW	4
5	114111	CURTAIN,LONG,19 X 34 1/4,EUCCW	2
6	204949	CURTAIN,SHORT,10 X 32,NUCCW E2	1
7	205432	ROD,CURTAIN,5/16 X 32"LG.SST,UCCW	3
8	206581	ROD,CURTAIN,5/16 X 34 1/4"LG.SST,UCCW	4
9	329719-1	BAFFLE, CURTAIN HANGER.MANIFOLD MTD,RH	2
10	329720-1	BAFFLE, CURTAIN HANGER,HOOD MTD,LH	2
11	330497	BAFFLE, CURTAIN ,BLANK,HOOD MTD	1
12	331200-2	BAFFLE, CURTAIN HANGER,AUX. RINSE CENTER,L-R	1

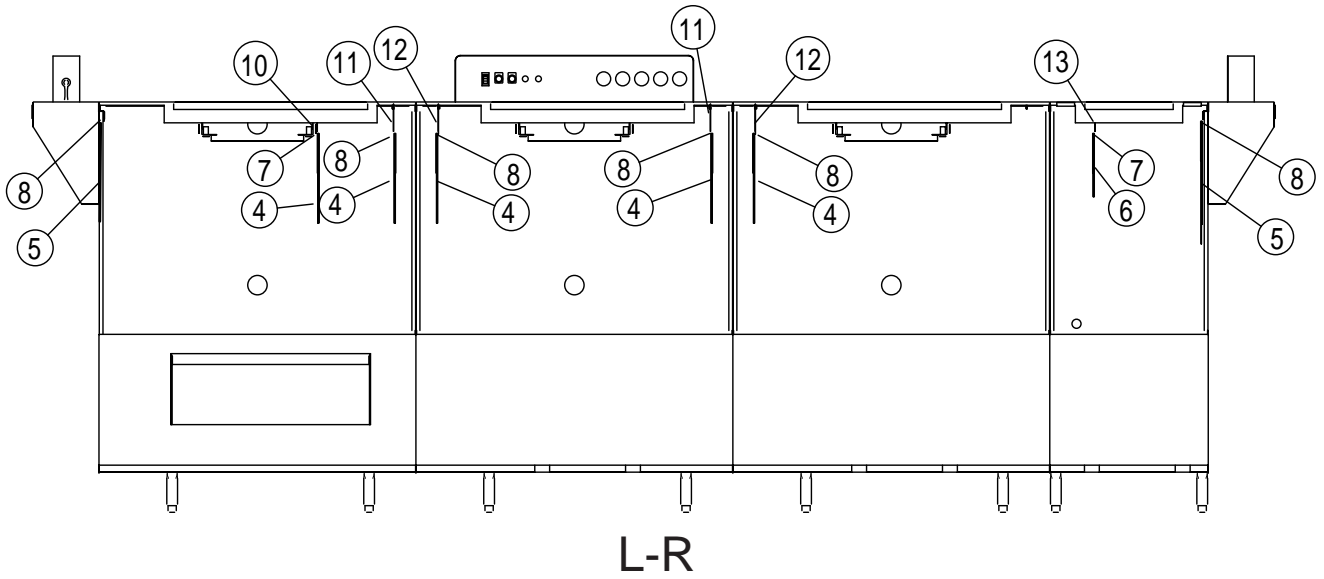
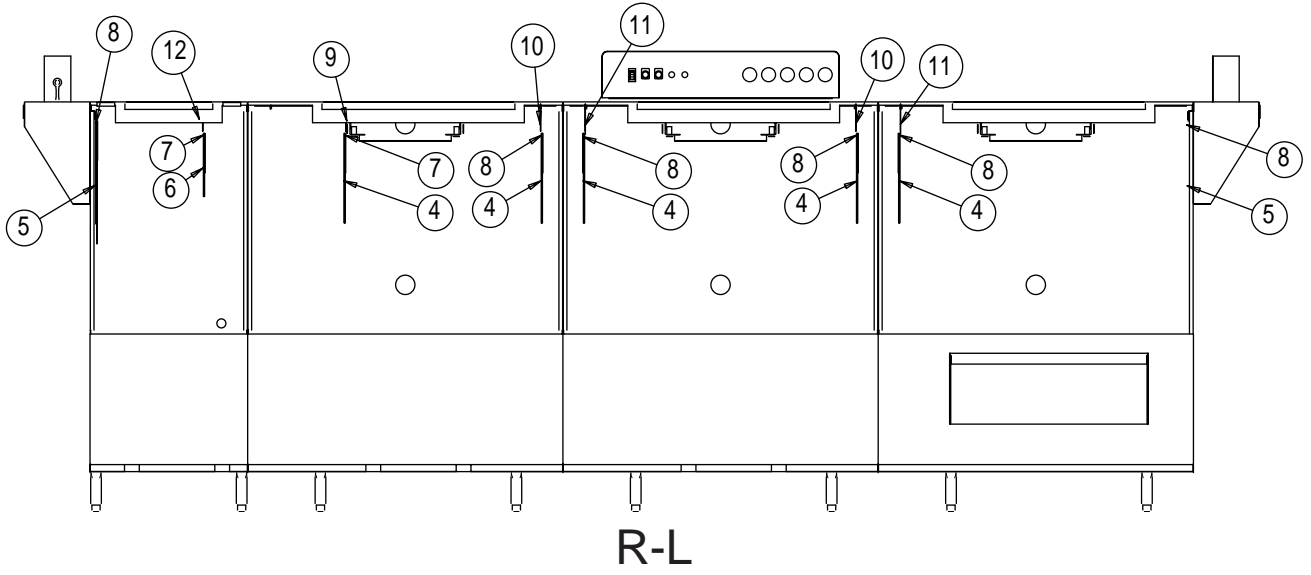

**R-L**

Item No.	Part No.	Description	Qty.
1	100734	HEX HEAD, 1/4-20 X 1/2 SST	12
2	106026	WASHER,FLAT,1/4x5/8x.06 SST	12
3	106482	WASHER,LOCK,1/4 SPLIT,SST	12
4	112445	CURTAIN,SHORT,14 X 32,NUCCW	5
5	114111	CURTAIN,LONG,19 X 34 1/4,EUCCW	2
6	204949	CURTAIN,SHORT,10 X 32,NUCCW AUX. RINSE	1
7	205432	ROD,CURTAIN,5/16 X 32"LG.SST,UCCW	2
8	206581	ROD,CURTAIN,5/16 X 34 1/4"LG.SST,UCCW	6
9	329719-2	BAFFLE, CURTAIN HANGER.MANIFOLD MTD,LH	1
10	329720-1	BAFFLE, CURTAIN HANGER,HOOD MTD,LH	2
11	329720-2	BAFFLE, CURTAIN HANGER,HOOD MTD,RH	2
12	331200-1	BAFFLE, CURTAIN HANGER,AUX. RINSE CENTER,R-L	1

**L-R**

Item No.	Part No.	Description	Qty.
1	100734	HEX HEAD, 1/4-20 X 1/2 SST	12
2	106026	WASHER,FLAT,1/4x5/8x.06 SST	12
3	106482	WASHER,LOCK,1/4 SPLIT,SST	12
4	112445	CURTAIN,SHORT,14 X 32,NUCCW	5
5	114111	CURTAIN,LONG,19 X 34 1/4,EUCCW	2
6	204949	CURTAIN,SHORT,10 X 32,NUCCW E2	1
7	205432	ROD,CURTAIN,5/16 X 32"LG.SST,UCCW	2
8	206581	ROD,CURTAIN,5/16 X 34 1/4"LG.SST,UCCW	6
9	329088	HOOD WELDMENT,C4R-B,ELEC/STEAM	1
10	329719-1	BAFFLE, CURTAIN HANGER.MANIFOLD MTD,RH	1
11	329720-1	BAFFLE, CURTAIN HANGER,HOOD MTD,LH	2
12	329720-2	BAFFLE, CURTAIN HANGER,HOOD MTD,RH	2

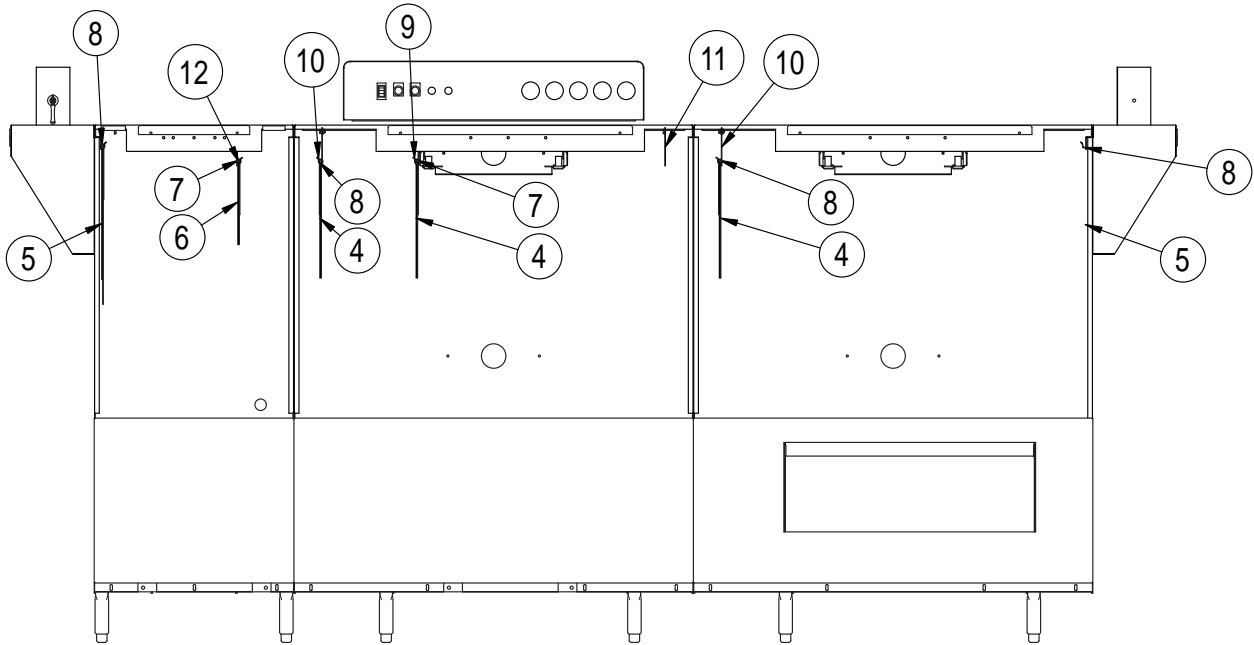

R-L

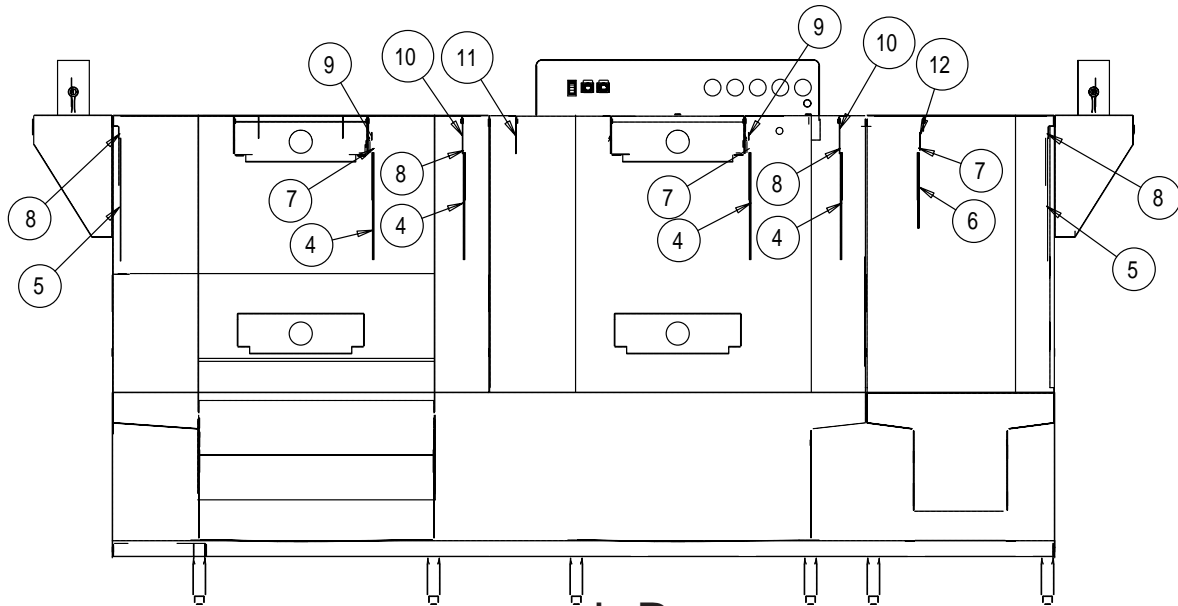

L-R



**R-L**

Item No.	Part No.	Description	Qty.
1	100734	HEX HEAD, 1/4-20 X 1/2 SST	8
2	106026	WASHER,FLAT,1/4x5/8x.06 SST	8
3	106482	WASHER,LOCK,1/4 SPLIT,SST	8
4	112445	CURTAIN,SHORT,14 X 32,NUCCW	3
5	114111	CURTAIN,LONG,19 X 34 1/4,EUCCW	2
6	204949	CURTAIN,SHORT,10 X 32,NUCCW AUX. RINSE	1
7	205432	ROD,CURTAIN,5/16 X 32"LG.SST,UCCW	2
8	206581	ROD,CURTAIN,5/16 X 34 1/4"LG.SST,UCCW	4
9	329719-2	BAFFLE, CURTAIN HANGER.MANIFOLD MTD,LH	1
10	329720-2	BAFFLE, CURTAIN HANGER,HOOD MTD,RH	2
11	330497	BAFFLE, CURTAIN ,BLANK,HOOD MTD	1
12	331200-1	BAFFLE, CURTAIN HANGER,AUX. RINSE CENTER,R-L	1

**L-R**

Item No.	Part No.	Description	Qty.
1	100734	HEX HEAD, 1/4-20 X 1/2 SST	8
2	106026	WASHER,FLAT,1/4x5/8x.06 SST	8
3	106482	WASHER,LOCK,1/4 SPLIT,SST	8
4	112445	CURTAIN,SHORT,14 X 32,NUCCW	3
5	114111	CURTAIN,LONG,19 X 34 1/4,EUCCW	2
6	204949	CURTAIN,SHORT,10 X 32,NUCCW AUX. RINSE	1
7	205432	ROD,CURTAIN,5/16 X 32"LG.SST,UCCW	2
8	206581	ROD,CURTAIN,5/16 X 34 1/4"LG.SST,UCCW	4
9	329719-2	BAFFLE, CURTAIN HANGER.MANIFOLD MTD,LH	1
10	329720-2	BAFFLE, CURTAIN HANGER,HOOD MTD,RH	2
11	330497	BAFFLE, CURTAIN ,BLANK,HOOD MTD	1
12	331200-1	BAFFLE, CURTAIN HANGER,AUX. RINSE CENTER,R-L	1

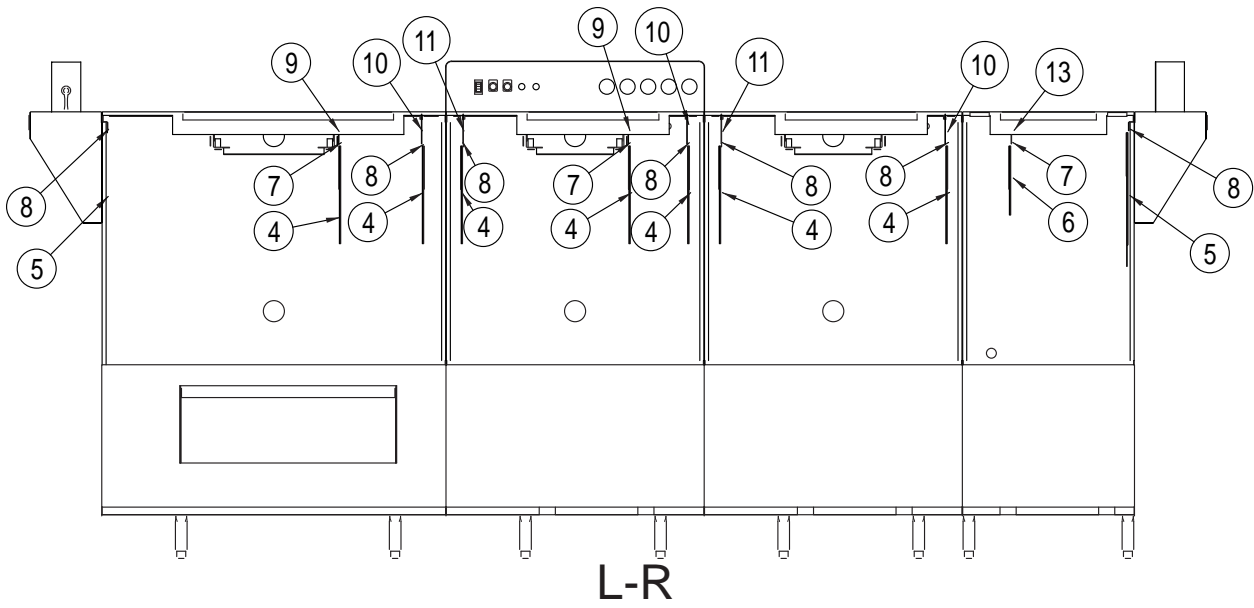
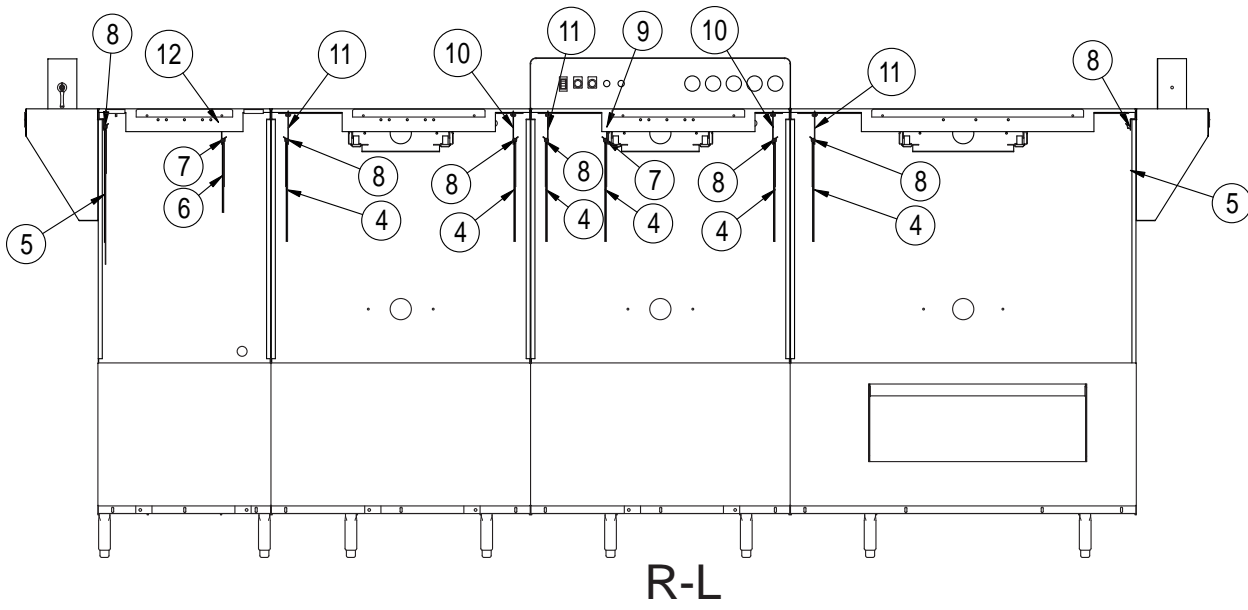

**R-L**

Item No.	Part No.	Description	Qty.
1	100734	HEX HEAD, 1/4-20 X 1/2 SST	14
2	106026	WASHER,FLAT,1/4x5/8x.06 SST	14
3	106482	WASHER,LOCK,1/4 SPLIT,SST	14
4	112445	CURTAIN,SHORT,14 X 32,NUCCW	6
5	114111	CURTAIN,LONG,19 X 34 1/4,EUCCW	2
6	204949	CURTAIN,SHORT,10 X 32,NUCCW E2	1
7	205432	ROD,CURTAIN,5/16 X 32"LG.SST,UCCW	2
8	206581	ROD,CURTAIN,5/16 X 34 1/4"LG.SST,UCCW	7
9	329719-2	BAFFLE, CURTAIN HANGER.MANIFOLD MTD,LH	1
10	329720-1	BAFFLE, CURTAIN HANGER,HOOD MTD,LH	2
11	329720-2	BAFFLE, CURTAIN HANGER,HOOD MTD,RH	3
12	331200-1	BAFFLE, CURTAIN HANGER,AUX. RINSE CENTER,R-L	1

**L-R**

Item No.	Part No.	Description	Qty.
1	100734	HEX HEAD, 1/4-20 X 1/2 SST	16
2	106026	WASHER,FLAT,1/4x5/8x.06 SST	16
3	106482	WASHER,LOCK,1/4 SPLIT,SST	16
4	112445	CURTAIN,SHORT,14 X 32,NUCCW	7
5	114111	CURTAIN,LONG,19 X 34 1/4,EUCCW	2
6	204949	CURTAIN,SHORT,10 X 32,NUCCW AUX. RINSE	1
7	205432	ROD,CURTAIN,5/16 X 32"LG.SST,UCCW	3
8	206581	ROD,CURTAIN,5/16 X 34 1/4"LG.SST,UCCW	7
9	329719-1	BAFFLE, CURTAIN HANGER.MANIFOLD MTD,RH	2
10	329720-1	BAFFLE, CURTAIN HANGER,HOOD MTD,LH	3
11	329720-2	BAFFLE, CURTAIN HANGER,HOOD MTD,RH	2
12	330223	HOOD WELDMENT,C3R-B,ELEC/STEAM	1
13	331200-2	BAFFLE, CURTAIN HANGER,AUX. RINSE CENTER,L-R	1

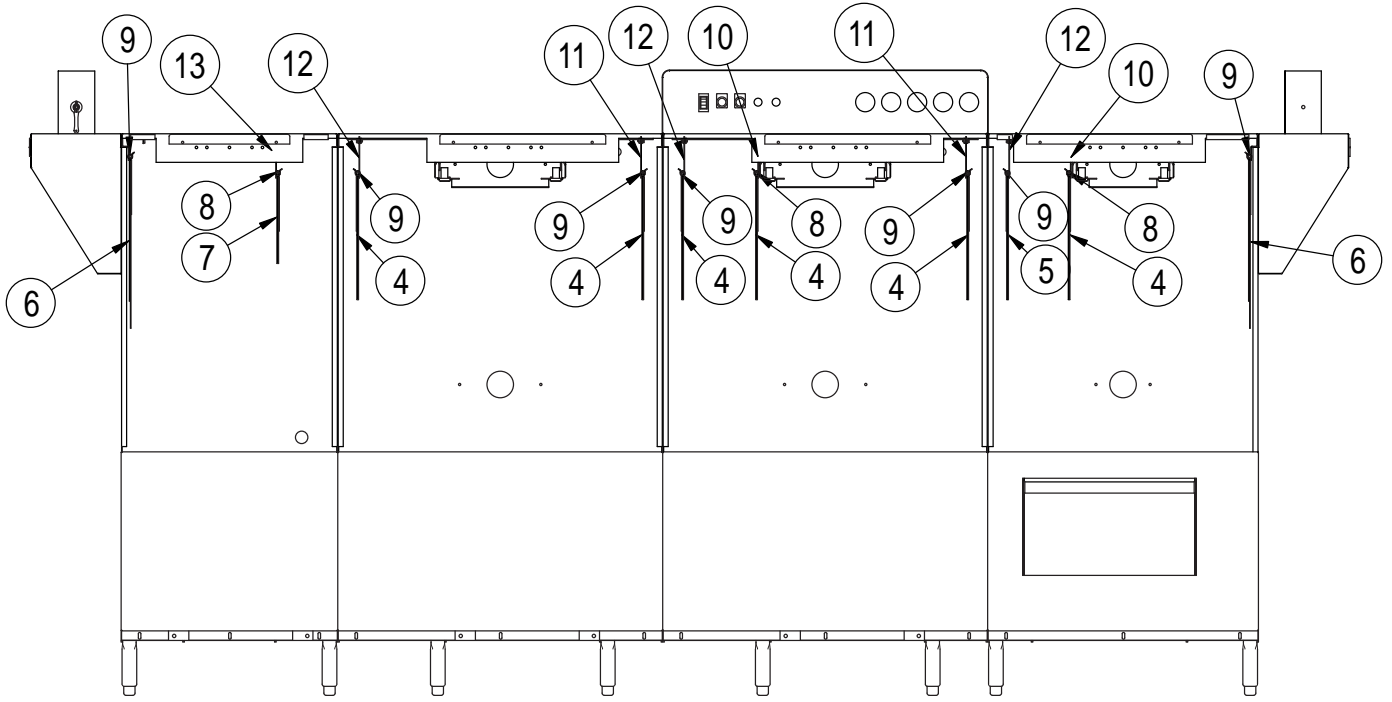

R-L

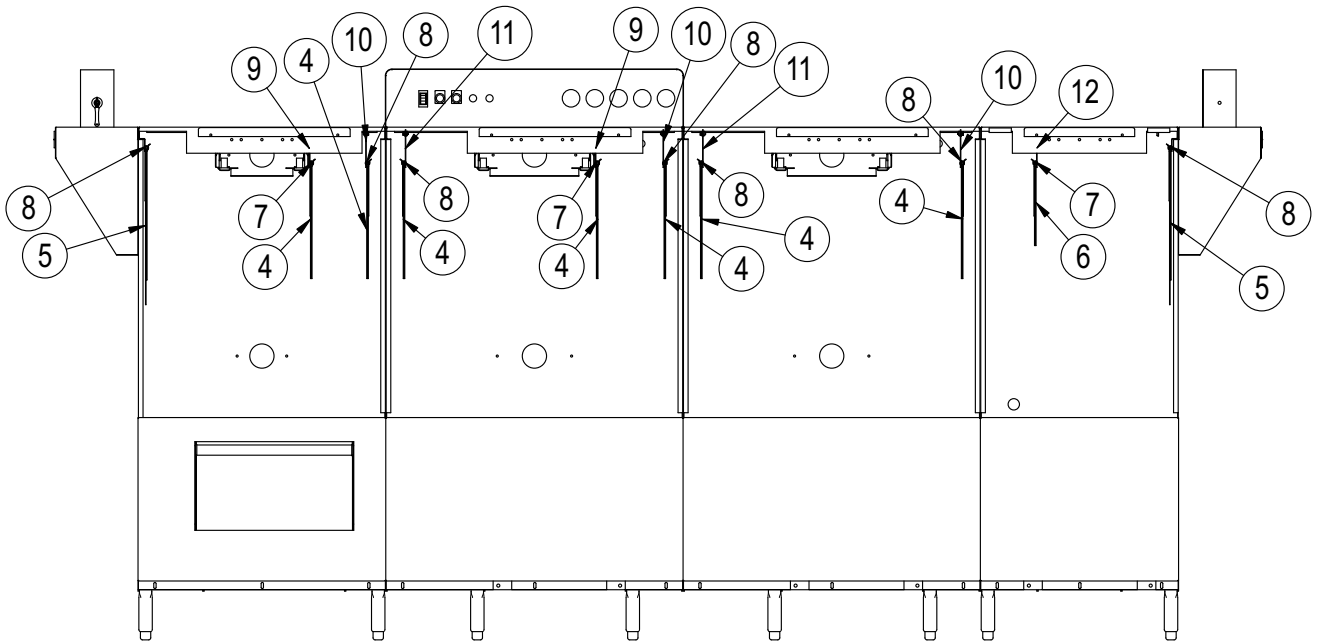

L-R

**R-L**

Item No.	Part No.	Description	Qty.
1	100734	CAP SCREW,HEX HEAD,1/4-20 X 1/2 SST	16
2	106026	WASHER,FLAT,1/4x5/8x.06 SST	16
3	106482	WASHER,LOCK,1/4 SPLIT,SST	16
4	112445	CURTAIN,SHORT,14 X 32,NUCCW	6
5	114110	CURTAIN,SHORT,14 X 34 1/4,EUCCW	1
6	114111	CURTAIN,LONG,19 X 34 1/4,EUCCW	2
7	204949	CURTAIN,SHORT,10 X 32,NUCCW E2	1
8	205432	ROD,CURTAIN,5/16 X 32"LG.SST,UCCW	3
9	206581	ROD,CURTAIN,5/16 X 34 1/4"LG.SST,UCCW	7
10	329719-2	BAFFLE, CURTAIN HANGER.MANIFOLD MTD,LH	2
11	329720-1	BAFFLE, CURTAIN HANGER,HOOD MTD,LH	2
12	329720-2	BAFFLE, CURTAIN HANGER,HOOD MTD,RH	3
13	331200-1	BAFFLE, CURTAIN HANGER,E2 CENTER,R-L	1

**L-R**

Item No.	Part No.	Description	Qty.
1	100734	HEX HEAD, 1/4-20 X 1/2 SST	16
2	106026	WASHER,FLAT,1/4x5/8x.06 SST	16
3	106482	WASHER,LOCK,1/4 SPLIT,SST	16
4	112445	CURTAIN,SHORT,14 X 32,NUCCW	7
5	114111	CURTAIN,LONG,19 X 34 1/4,EUCCW	2
6	204949	CURTAIN,SHORT,10 X 32,NUCCW AUX. RINSE	1
7	205432	ROD,CURTAIN,5/16 X 32"LG.SST,UCCW	3
8	206581	ROD,CURTAIN,5/16 X 34 1/4"LG.SST,UCCW	7
9	329719-1	BAFFLE, CURTAIN HANGER.MANIFOLD MTD,RH	2
10	329720-1	BAFFLE, CURTAIN HANGER,HOOD MTD,LH	3
11	329720-2	BAFFLE, CURTAIN HANGER,HOOD MTD,RH	2
12	331200-2	BAFFLE, CURTAIN HANGER, AUX. RINSE CENTER,L-R	1

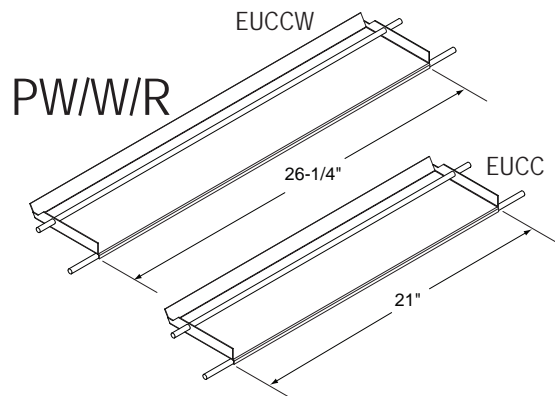
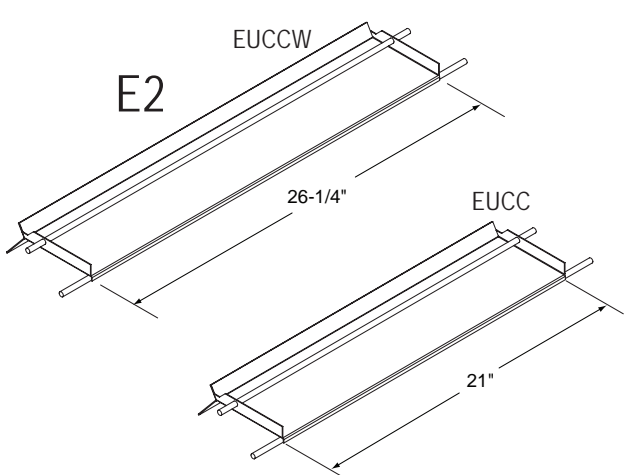
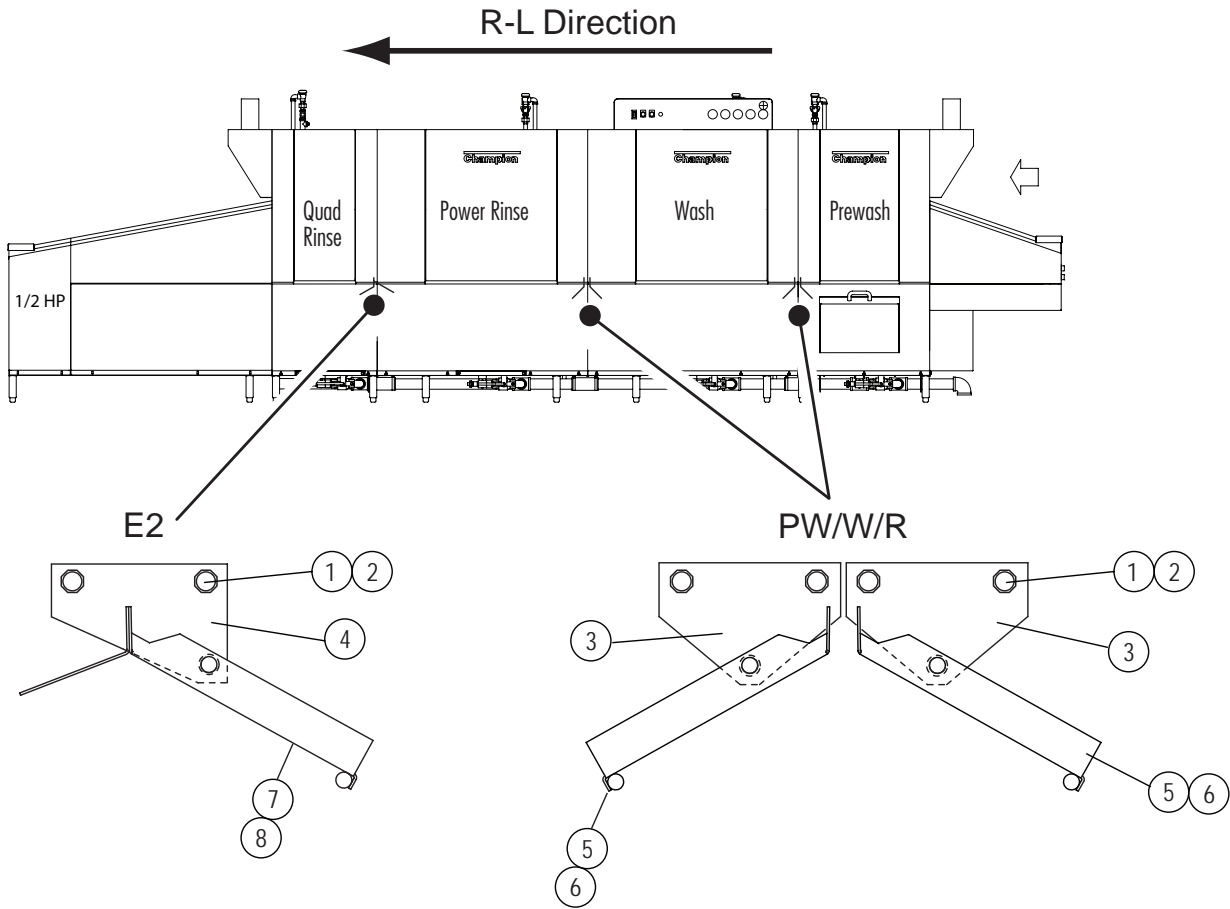

Item No.	Part No.	Description	Qty.
1	100734	BOLT, HEX HD. 1/4-20 X 1/2"	2 PER BRACKET
2	106482	WASHER, LOCK 1/4" SPLIT	2 PER BRACKET
3	329185	BRACKET, PW/W/R BAFFLE	2 PER BAFFLE
4	331338	BRACKET, E2 BAFFLE	2 PER BAFFLE
5	329805	BAFFLE, EUCCW, PW/W/R	2 PER SECTION
6	329129	BAFFLE, EUCC, PW/W/R	2 PER SECTION
7	331337	BAFFLE, EUCCW, E2	1 PER SECTION
8	331423	BAFFLE, EUCC, E2	1 PER SECTION

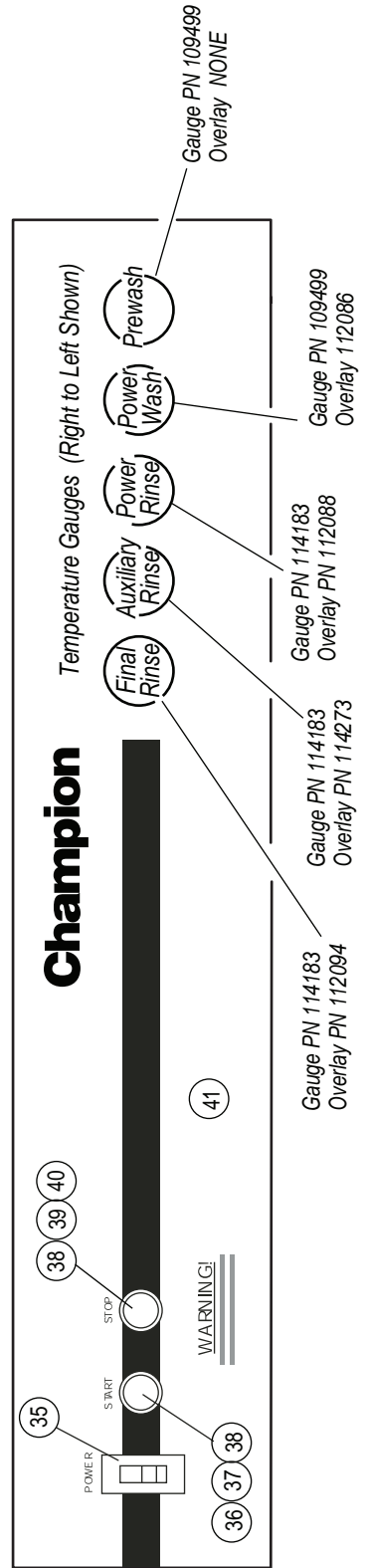
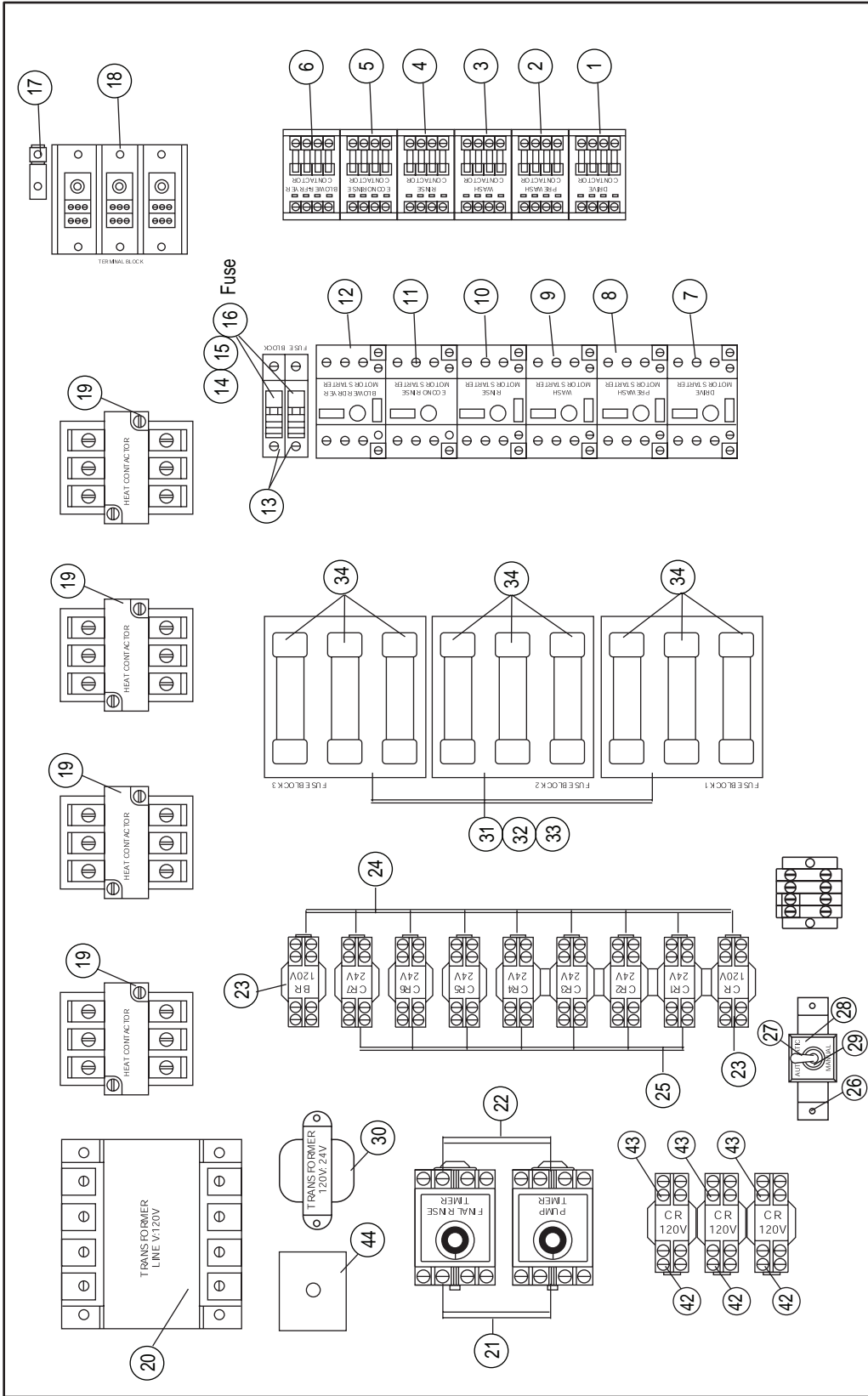



Item No.	Part No.	Description	Qty.
1	108122	Contactora, Motor 12A, Drive	1
2	108122	Contactora, Motor 12A, Prewash	1
3	108122	Contactora, Motor 12A, Wash	1
4	108122	Contactora, Motor 12A, Rinse	1
5	108122	Contactora, Motor 12A, Eco Rinse	1
6	108122	Contactora, Motor 12A, Steam Blower Dryer	1
7	111627	Starter, Motor 1/2HP Drive 208-240/60/3	1
---	110803	Starter, Motor 1/2HP Drive 380-415/60/3	1
---	110803	Starter, Motor 1/2HP Drive 480/60/3	1
---	110802	Starter, Motor 1/2HP Drive 575/60/3	1
8	110805	Starter, Motor 1HP Prewash 208-240/60/3	1
---	110804	Starter, Motor 1HP Prewash 380-415/60/3	1
---	110804	Starter, Motor 1HP Prewash 480/60/3	1
---	110803	Starter, Motor 1HP Prewash 575/60/3	1
---	112691	Starter, Motor 2HP Prewash 208-240/60/3	1
---	110805	Starter, Motor 2HP Prewash 380-415/60/3	1
---	110805	Starter, Motor 2HP Prewash 480/60/3	1
---	112692	Starter, Motor 2HP Prewash 575/60/3	1
---	110807	Starter, Motor 3HP Prewash 208-240/60/3	1
---	110806	Starter, Motor 3HP Prewash 380-415/60/3	1
---	110806	Starter, Motor 3HP Prewash 480/60/3	1
---	110805	Starter, Motor 3HP Prewash 575/60/3	1
9	110807	Starter Motor 3HP Wash 208-240/60/3	1
---	110806	Starter Motor 3HP Wash 380-415/60/3	1
---	110806	Starter Motor 3HP Wash 480/60/3	1
---	110805	Starter Motro 3HP Wash 575/60/3	1
10	110807	Starter Motor 3HP Power Rinse 208-240/60/3	1
---	110806	Starter Motor 3HP Power Rinse 380-415/60/3	1
---	110806	Starter Motor 3HP Power Rinse 480/60/3	1
---	110805	Starter Motor 3HP Power Rinse 575/60/3	1
11	110803	Starter Motor 1/4HP Auxiliary Rinse 208-240/60/3	1
---	110802	Starter Motor 1/4HP Auxiliary Rinse 380-415/60/3	1
---	110802	Starter Motor 1/4HP Auxiliary Rinse 480/60/3	1
---	110806	Starter Motor 1/4HP Auxiliary Rinse 575/60/3	1
12	110807	Starter Motor 2HP Steam Blower Dryer 208-240/60/3	1
---	110806	Starter Motor 2HP Steam Blower Dryer 380-415/60/3	1
---	110805	Starter Motor 2HP Steam Blower Dryer 480/60/3	1
---	110805	Starter Motor 2HP Steam Blower Dryer 575/60/3	1
13	111153	Block, fuse	2
14	111823	Fuse, 6A 208-240/60/3	2
15	111822	Fuse, 5A 380-415/60/3	2
16	111821	Fuse, 3A 460-480/60/3 575/60/3	2
17	103310	Lug, Wire Ground (Use with 115A Terminal Block)	1
---	103311	Lug, Wiire Ground (Use with 200A or 310A Terminal Block)	1

(Parts continued on next page)

Control Cabinet (From S/N J2098 up to J08102541)

Item No.	Part No.	Description	Qty.
18	111833	Block, Terminal 185A	1
---	109014	Block, Terminal 310A	1
19	111827	Contactora, Heat Electric 60A 3P	A/R
20	180081	Transformer, Control 750VA, 208-240/480/60/3:120VAC	1
---	112792	Transformer, Control 750VA 575/60/3:120VAC	1
21	112351	Timer, 0-6 minute	2
22	112352	Socket, Timer	2
23	111068	Relay, 120VAC	2
24	111036	Socket, Relay	A/R
25	111067	Relay, 24VAC	A/R
26	304326	Bracket, Switch	1
27	107198	Switch, Toggle (Bypass)	1
28	108370	Washer, Lock	1
29	104858	Nameplate, Automatic-Manual	1
30	111277	Transformer, Control 120VAC:24VAC	1
31	180465	Fuse Block 600V 35A to 60A	A/R
32	180464	Fuse Block 600V 25A to 30A	A/R
33	108424	Fuse Block 600V 70A to 100A	A/R
34	180462	Fuse 30A T	A/R
---	180470	Fuse 35A T	A/R
---	180463	Fuse 40A T	A/R
---	180471	Fuse 45A T	A/R
---	116963	Fuse 50A T	A/R
---	109659	Fuse 60A T	A/R
---	180060	Fuse 70A T	A/R
---	180059	Fuse 80A T	A/R
---	180448	Fuse 90A T	A/R
---	180042	Fuse 100A T	A/R
35	111980	Breaker, Circuit ON/OFF 5A	1
36	111614	Push button Start GREEN	1
37	111617	Block, Contact N.O.	1
38	113140	Boot, Silicon Push button	1
39	111615	Push button Stop RED	1
40	111616	Block, Contact N.C.	1
41	114117	Decal EUC 6/8 with Prewash L-R	1
---	114159	Decal EUC 6/8 with Prewash R-L	1
---	114286	Decal EUC 4 with Prewash L-R	1
---	114287	Decal EUC 6/8 without Prewash L-R	1
---	114307	Decal EUC 6/8 without Prewash R-L	1
42	112382	Relay 3PDT 120V, 10A	3
43	112415	Socket, Relay 3PDT	3
44	114413	Timer, 30 seconds	1
---	900725	Kit, Push button GREEN (includes items 36,37,38)	A/R
---	900726	Kit, Push button RED (includes items 38,39,40)	A/R

***This Page  
Intentionally  
Left Blank***

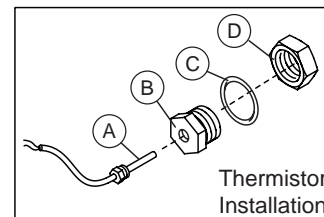
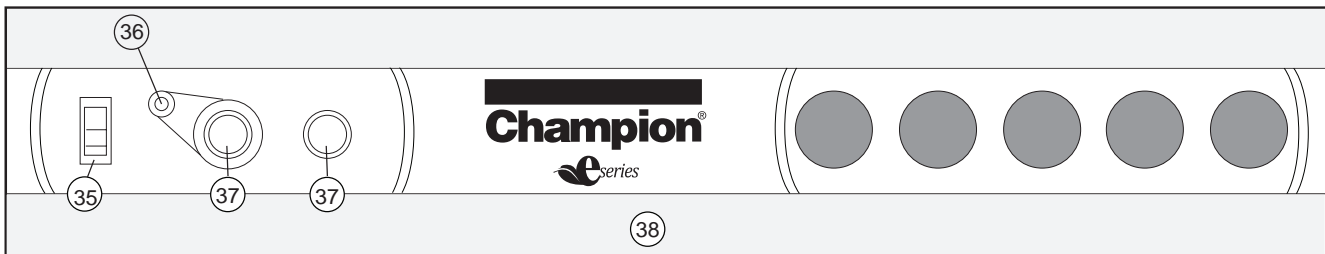
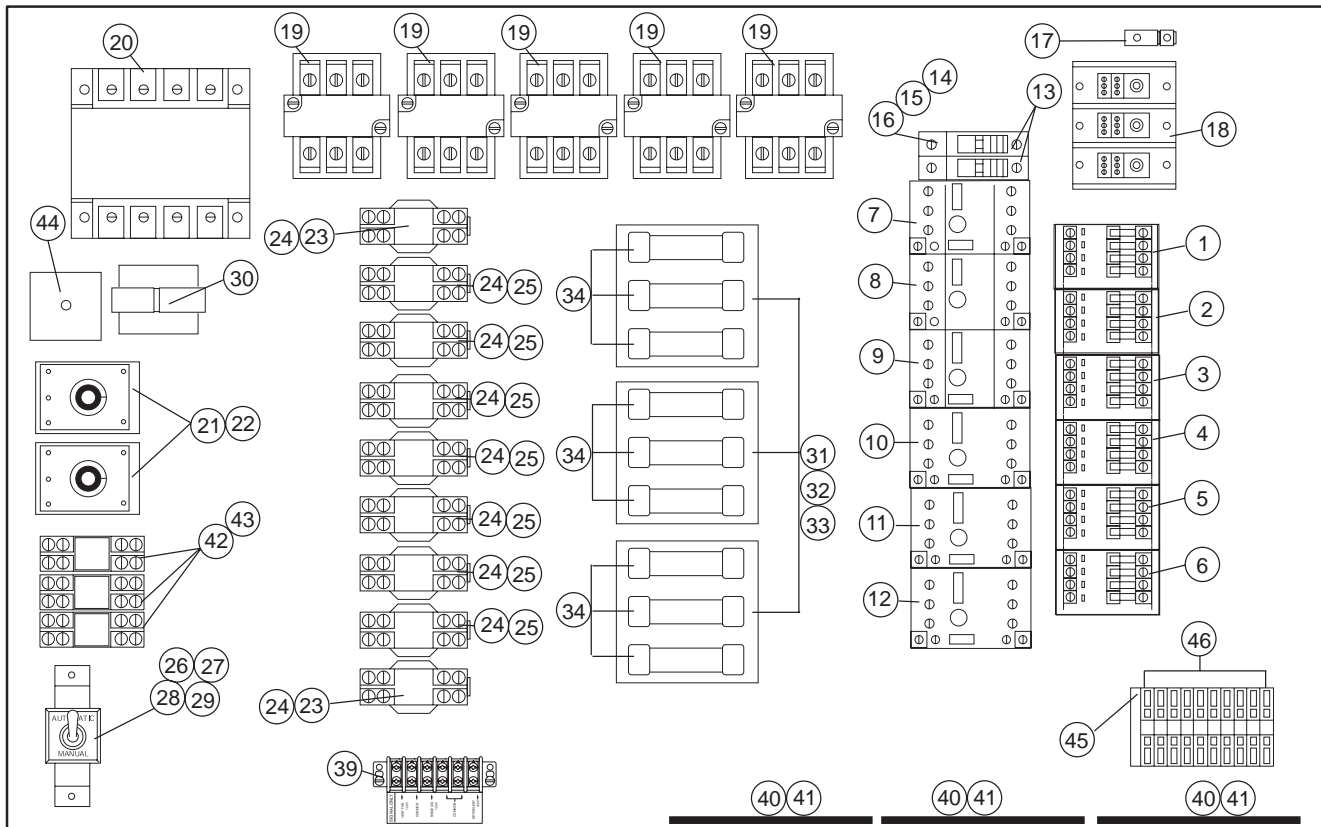

Item No.	Part No.	Description	Qty.
1	108122	Contactora, Motor 12A, Drive	1
2	108122	Contactora, Motor 12A, Prewash	1
3	108122	Contactora, Motor 12A, Wash	1
4	108122	Contactora, Motor 12A, Rinse	1
5	108122	Contactora, Motor 12A, Eco Rinse	1
6	108122	Contactora, Motor 12A, Steam Blower Dryer	1
7	111627	Starter, Motor 1/2HP Drive 208-240/60/3	1
---	110803	Starter, Motor 1/2HP Drive 380-415/60/3	1
---	110803	Starter, Motor 1/2HP Drive 480/60/3	1
---	110802	Starter, Motor 1/2HP Drive 575/60/3	1
8	110805	Starter, Motor 1HP Prewash 208-240/60/3	1
---	110804	Starter, Motor 1HP Prewash 380-415/60/3	1
---	110804	Starter, Motor 1HP Prewash 480/60/3	1
---	110803	Starter, Motor 1HP Prewash 575/60/3	1
---	112691	Starter, Motor 2HP Prewash 208-240/60/3	1
---	110805	Starter, Motor 2HP Prewash 380-415/60/3	1
---	110805	Starter, Motor 2HP Prewash 480/60/3	1
---	112692	Starter, Motor 2HP Prewash 575/60/3	1
---	110807	Starter, Motor 3HP Prewash 208-240/60/3	1
---	110806	Starter, Motor 3HP Prewash 380-415/60/3	1
---	110806	Starter, Motor 3HP Prewash 480/60/3	1
---	110805	Starter, Motor 3HP Prewash 575/60/3	1
9	110807	Starter Motor 3HP Wash 208-240/60/3	1
---	110806	Starter Motor 3HP Wash 380-415/60/3	1
---	110806	Starter Motor 3HP Wash 480/60/3	1
---	110805	Starter Motro 3HP Wash 575/60/3	1
10	110807	Starter Motor 3HP Power Rinse 208-240/60/3	1
---	110806	Starter Motor 3HP Power Rinse 380-415/60/3	1
---	110806	Starter Motor 3HP Power Rinse 480/60/3	1
---	110805	Starter Motor 3HP Power Rinse 575/60/3	1
11	110803	Starter Motor 1/4HP Auxiliary Rinse 208-240/60/3	1
---	110802	Starter Motor 1/4HP Auxiliary Rinse 380-415/60/3	1
---	110802	Starter Motor 1/4HP Auxiliary Rinse 480/60/3	1
---	110806	Starter Motor 1/4HP Auxiliary Rinse 575/60/3	1
12	110807	Starter Motor 2HP Steam Blower Dryer 208-240/60/3	1
---	110806	Starter Motor 2HP Steam Blower Dryer 380-415/60/3	1
---	110805	Starter Motor 2HP Steam Blower Dryer 480/60/3	1
---	110805	Starter Motor 2HP Steam Blower Dryer 575/60/3	1
13	111153	Block, fuse	2
14	111823	Fuse, 6A 208-240/60/3	2
15	111822	Fuse, 5A 380-415/60/3	2
16	111821	Fuse, 3A 460-480/60/3 575/60/3	2
17	103310	Lug, Wire Ground (Use with 115A Terminal Block)	1
---	103311	Lug, Wiire Ground (Use with 200A or 310A Terminal Block)	1

(Parts continued on next page)

Control Cabinet (S/N J08102541 up to J10012728)

Item No.	Part No.	Description	Qty.
18	111833	Block, Terminal 185A	1
---	109014	Block, Terminal 310A	1
19	111827	Contactor, Heat Electric 60A 3P	A/R
20	180081	Transformer, Control 750VA, 208-240/480/60/3:120VAC	1
---	112792	Transformer, Control 750VA 575/60/3:120VAC	1
21	112351	Timer, 0-6 minute	2
22	112352	Socket, Timer	2
23	111068	Relay, 120VAC	2
24	111036	Socket, Relay	A/R
25	111067	Relay, 24VAC	A/R
26	304326	Bracket, Switch	1
27	107198	Switch, Toggle (Bypass)	1
28	108370	Washer, Lock	1
29	104858	Nameplate, Automatic-Manual	1
30	111277	Transformer, Control 120VAC:24VAC	1
31	180465	Fuse Block 600V 35A to 60A	A/R
32	180464	Fuse Block 600V 25A to 30A	A/R
33	108424	Fuse Block 600V 70A to 100A	A/R
34	180462	Fuse 30A T	A/R
---	180470	Fuse 35A T	A/R
---	180463	Fuse 40A T	A/R
---	180471	Fuse 45A T	A/R
---	116963	Fuse 50A T	A/R
---	109659	Fuse 60A T	A/R
---	180060	Fuse 70A T	A/R
---	180059	Fuse 80A T	A/R
---	180448	Fuse 90A T	A/R
---	180042	Fuse 100A T	A/R
35	114505	Breaker, Circuit, 14A, ON/OFF	1
36	702804	LED Assembly	1
37	0512213	Switch, Piezo Momentary 22mm	2
38	114439.1	Decal, Standard EUCC	1
39	100294	Board, Terminal 6PT	1
40	114508	Cable Assembly	A/R
41	114489	Display, Digital	3
42	112382	Relay 3PDT 120V, 10A	3
43	112415	Socket, Relay 3PDT	3
44	114413	Timer, 30 seconds	1
45	114521	End Cover, Single Terminal D-MZB	1
46	114520	Terminal, Single MZB 1.5 NS35	10
<p>Temperature sensing thermistors are installed in the wash tanks and final rinse piping. The temperature signals are connected to the digital temperature displays (item 41) in the main control cabinet.</p>			
A	114435	Thermistor, 10K 36" Lead	A/R
B	0512299	Adapter, Thermistor	A/R
C	0501836	O-ring	A/R
D	201029	Locknut, 1/2" NPT NP	A/R

***This Page  
Intentionally  
Left Blank***

Control Cabinet (S/N J10012728 and above)

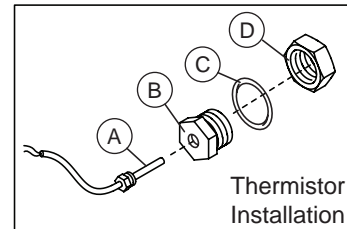
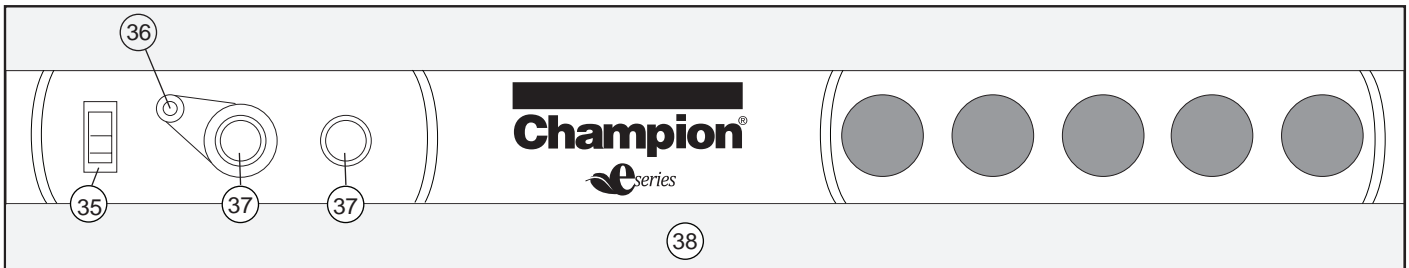
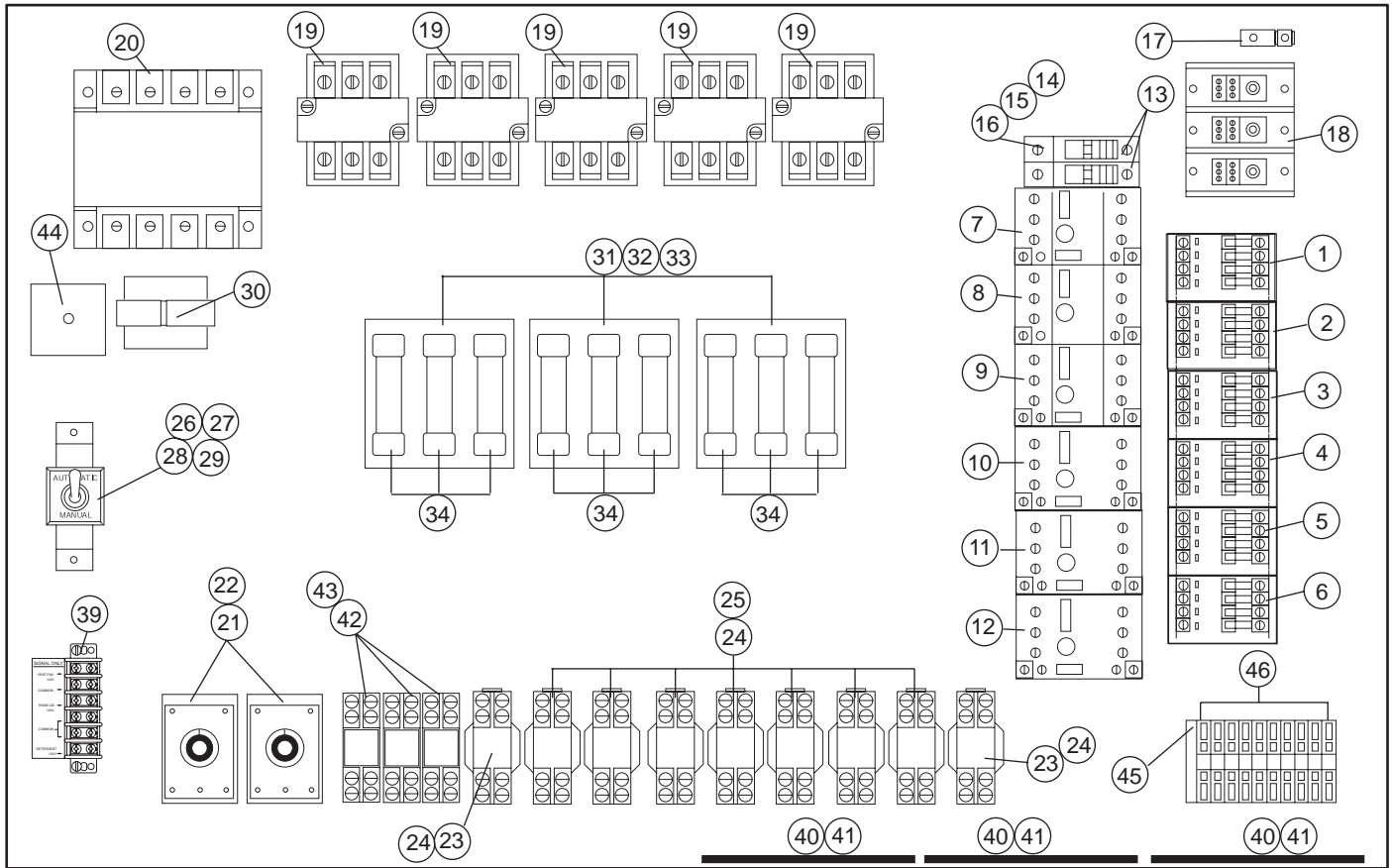



Item No.	Part No.	Description	Qty.
1	108122	Contactora, Motor 12A, Drive	1
2	108122	Contactora, Motor 12A, Prewash	1
3	108122	Contactora, Motor 12A, Wash	1
4	108122	Contactora, Motor 12A, Rinse	1
5	108122	Contactora, Motor 12A, Eco Rinse	1
6	108122	Contactora, Motor 12A, Steam Blower Dryer	1
7	111627	Starter, Motor 1/2HP Drive 208-240/60/3	1
---	110803	Starter, Motor 1/2HP Drive 380-415/60/3	1
---	110803	Starter, Motor 1/2HP Drive 480/60/3	1
---	110802	Starter, Motor 1/2HP Drive 575/60/3	1
8	110805	Starter, Motor 1HP Prewash 208-240/60/3	1
---	110804	Starter, Motor 1HP Prewash 380-415/60/3	1
---	110804	Starter, Motor 1HP Prewash 480/60/3	1
---	110803	Starter, Motor 1HP Prewash 575/60/3	1
---	112691	Starter, Motor 2HP Prewash 208-240/60/3	1
---	110805	Starter, Motor 2HP Prewash 380-415/60/3	1
---	110805	Starter, Motor 2HP Prewash 480/60/3	1
---	112692	Starter, Motor 2HP Prewash 575/60/3	1
---	110807	Starter, Motor 3HP Prewash 208-240/60/3	1
---	110806	Starter, Motor 3HP Prewash 380-415/60/3	1
---	110806	Starter, Motor 3HP Prewash 480/60/3	1
---	110805	Starter, Motor 3HP Prewash 575/60/3	1
9	110807	Starter Motor 3HP Wash 208-240/60/3	1
---	110806	Starter Motor 3HP Wash 380-415/60/3	1
---	110806	Starter Motor 3HP Wash 480/60/3	1
---	110805	Starter Motro 3HP Wash 575/60/3	1
10	110807	Starter Motor 3HP Power Rinse 208-240/60/3	1
---	110806	Starter Motor 3HP Power Rinse 380-415/60/3	1
---	110806	Starter Motor 3HP Power Rinse 480/60/3	1
---	110805	Starter Motor 3HP Power Rinse 575/60/3	1
11	110803	Starter Motor 1/4HP Auxiliary Rinse 208-240/60/3	1
---	110802	Starter Motor 1/4HP Auxiliary Rinse 380-415/60/3	1
---	110802	Starter Motor 1/4HP Auxiliary Rinse 480/60/3	1
---	110806	Starter Motor 1/4HP Auxiliary Rinse 575/60/3	1
12	110807	Starter Motor 2HP Steam Blower Dryer 208-240/60/3	1
---	110806	Starter Motor 2HP Steam Blower Dryer 380-415/60/3	1
---	110805	Starter Motor 2HP Steam Blower Dryer 480/60/3	1
---	110805	Starter Motor 2HP Steam Blower Dryer 575/60/3	1
13	111153	Block, fuse	2
14	111823	Fuse, 6A 208-240/60/3	2
15	111822	Fuse, 5A 380-415/60/3	2
16	111821	Fuse, 3A 460-480/60/3 575/60/3	2
17	103310	Lug, Wire Ground (Use with 115A Terminal Block)	1
---	103311	Lug, Wiire Ground (Use with 200A or 310A Terminal Block)	1

(Parts continued on next page)

Control Cabinet (S/N J08102541 and above)

Item No.	Part No.	Description	Qty.
18	111833	Block, Terminal 185A	1
---	109014	Block, Terminal 310A	1
19	111827	Contactor, Heat Electric 60A 3P	A/R
20	180081	Transformer, Control 750VA, 208-240/480/60/3:120VAC	1
---	112792	Transformer, Control 750VA 575/60/3:120VAC	1
21	112351	Timer, 0-6 minute	2
22	112352	Socket, Timer	2
23	111068	Relay, 120VAC	2
24	111036	Socket, Relay	A/R
25	111067	Relay, 24VAC	A/R
26	304326	Bracket, Switch	1
27	107198	Switch, Toggle (Bypass)	1
28	108370	Washer, Lock	1
29	104858	Nameplate, Automatic-Manual	1
30	111277	Transformer, Control 120VAC:24VAC	1
31	180465	Fuse Block 600V 35A to 60A	A/R
32	180464	Fuse Block 600V 25A to 30A	A/R
33	108424	Fuse Block 600V 70A to 100A	A/R
34	180462	Fuse 30A T	A/R
---	180470	Fuse 35A T	A/R
---	180463	Fuse 40A T	A/R
---	180471	Fuse 45A T	A/R
---	116963	Fuse 50A T	A/R
---	109659	Fuse 60A T	A/R
---	180060	Fuse 70A T	A/R
---	180059	Fuse 80A T	A/R
---	180448	Fuse 90A T	A/R
---	180042	Fuse 100A T	A/R
35	114505	Breaker, Circuit, 14A, ON/OFF	1
36	702804	LED Assembly	1
37	0512213	Switch, Piezo Momentary 22mm	2
38	114439.1	Decal, Standard EUCC	1
39	100294	Board, Terminal 6PT	1
40	114508	Cable Assembly	A/R
41	114489	Display, Digital	3
42	112382	Relay 3PDT 120V, 10A	3
43	112415	Socket, Relay 3PDT	3
44	114413	Timer, 30 seconds	1
45	114521	End Cover, Single Terminal D-MZB	1
46	114520	Terminal, Single MZB 1.5 NS35	10
<p>Temperature sensing thermistors are installed in the wash tanks and final rinse piping. The temperature signals are connected to the digital temperature displays (item 41) in the main control cabinet.</p>			
A	114435	Thermistor, 10K 36" Lead	A/R
B	0512299	Adapter, Thermistor	A/R
C	0501836	O-ring	A/R
D	201029	Locknut, 1/2" NPT NP	A/R

***This Page  
Intentionally  
Left Blank***

Standard 30" Door Assembly

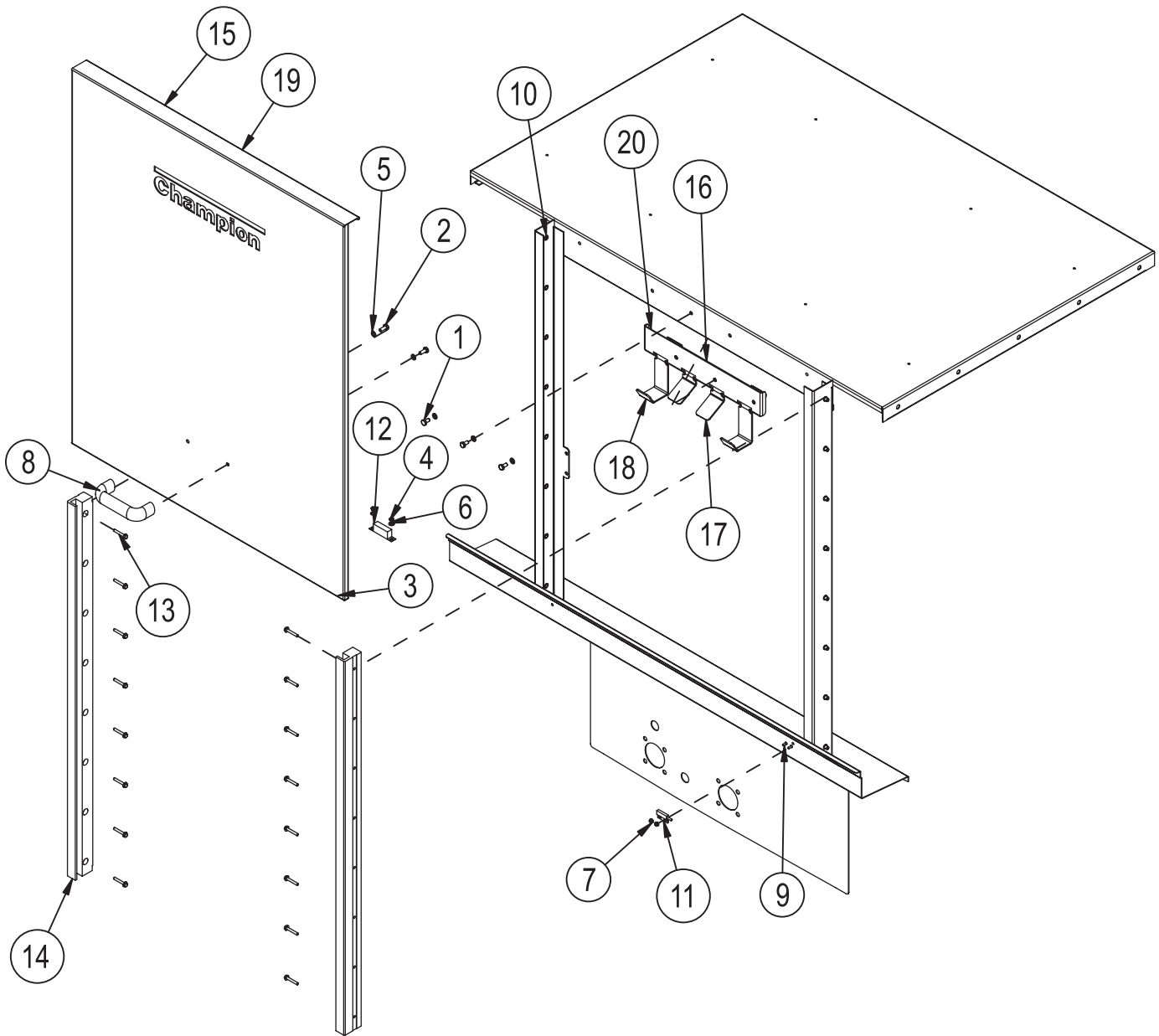

Item No.	Part No.	Description	Qty.
1	100734	HEX HEAD, 1/4-20 X 1/2 SST	3
2	100735	HEX HEAD, 1/4-20 X 5/8 SST	2
3	100750	SCREW, FLAT, 6-32 X 3/8 SST	2
4	104971	HEX GRIP NUT, 6-32 SST	2
5	106482	WASHER, LOCK, 1/4-20 SPLIT	5
6	107033	WASHER, FLAT SST	2
7	108954	HEX GRIP NUT, 6-32 SST W/NYLON	2
8	108966	HANDLE, DOOR	1
9	-----	STUD, NOT A REPLACEMENT PART	--
10	-----	RIVNUT, NOT A REPLACEMENT PART	--
11	113719	REED SWITCH	1
12	113937	MAGNET, REED SWITCH	1
13	114004	SCREW 10-32 x 1-1/4" HEX WASHER HEAD SST	16
14	114117	GUIDE, DOOR	2
15	330248	DOOR, 30" STD. EUC	
---	330249	DOOR, 14" STD. EUC	
---	330250	DOOR, 19" STD. EUC	
---	331304	DOOR, 30" HI-HOOD	
---	331305	DOOR, 14" HI-HOOD	
---	331306	DOOR, 19" HI-HOOD	
16	330301	BRACKET, DOOR CATCH 30"	1
---	330300	BRACKET, DOOR CATCH 14" / 19"	1
17	330303	STOP, DOOR CATCH COMBO 30"	1
---	330302	STOP, DOOR CATCH COMBO 14" / 19"	1
18	330305	DOOR CATCH, SINGLE DOOR 30"	1
---	330307	DOOR CATCH, SINGLE DOOR 14" / 19"	1

Split Door Assembly

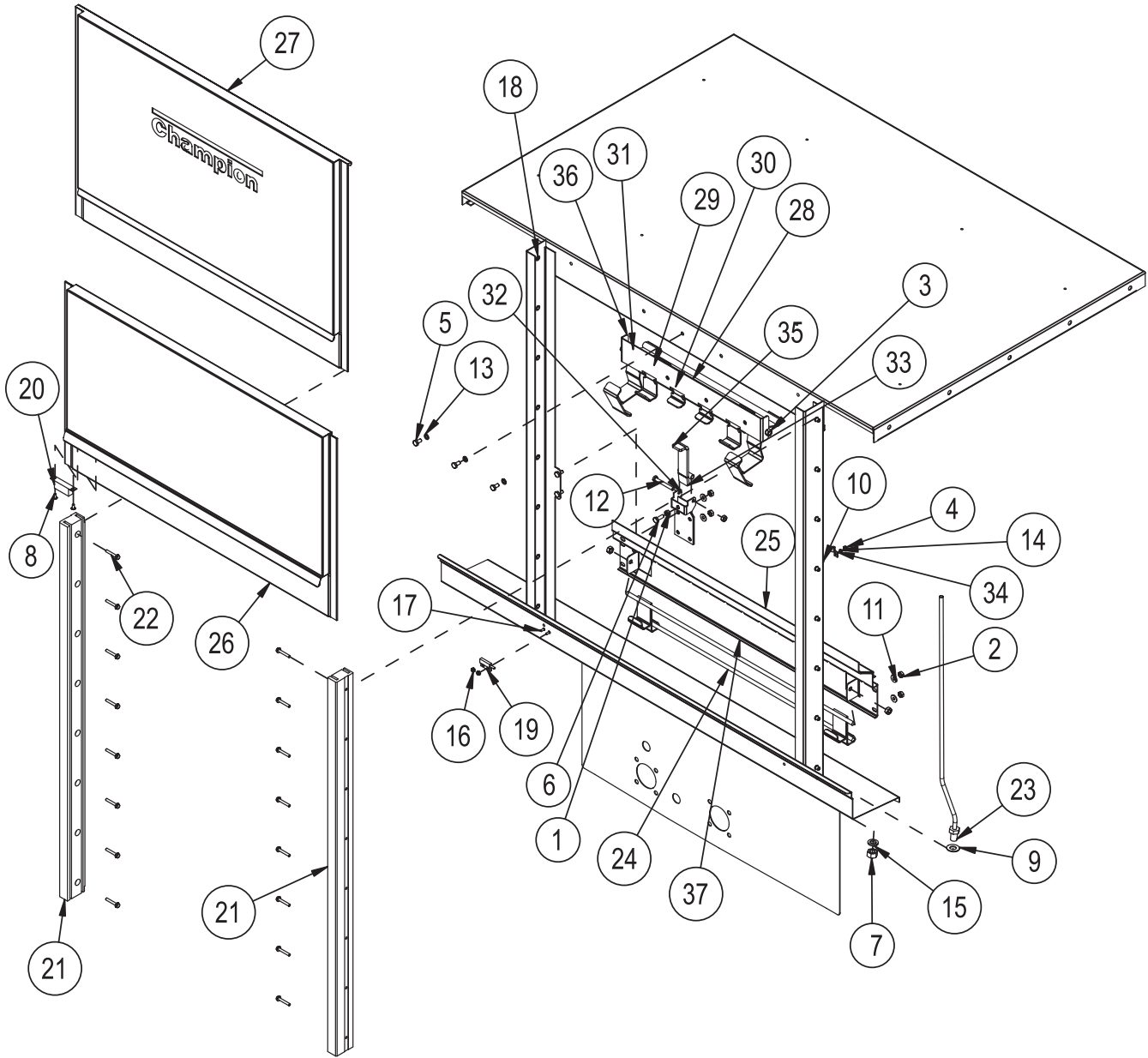

Item No.	Part No.	Description	Qty.
1	100003	HEX PLAIN NUT 1/4-20 SST	1
2	100141	HEX GRIP NUT 1/4-20 SST	5
3	100142	HEX GRIP NUT 5/16-18 SST	4
4	104971	HEX GRIP NUT, 6-32 SST	1
5	100734	HEX HEAD, 1/4-20 X 1/2 SST	7
6	100736	HEX HEAD, 1/4-20 X 3/4 SST	1
7	104584	HEX PLAIN NUT 1/2-13 SST	1
8	104624	SCREW, TRUSS HD, 8-32 X 1/2	2
9	104882	WASHER, FLAT SST	--
10	-----	STUD, NOT A REPLACEMENT PART	--
11	106026	WASHER, FLAT SST	4
12	106347	HEX HEAD, 1/4-20 X 2 SST	1
13	106482	WASHER, LOCK, 1/4-20 SPLIT	3
14	106486	WASHER LOCK SST	1
15	107589	WSHER, LOCK 1/2	1
16	108954	HEX GRIP NUT 6-32 W/NYLON	2
17	-----	STUD, NOT A REPLACEMENT PART	--
18	-----	RIVNUT, NOT A REPLACEMENT PART	--
19	113719	REED SWITCH	1
20	113937	MAGNET, REED SWITCH	1
21	113979	GUIDE DOOR	2
22	114004	SCREW, 10-32 x 1-1/4 HEX WASHER HEAD, SST	16
23	114100	REED SWITCH UPPER DOOR	1
24	329968	DOOR CATCH, LOWER, 30"	1
---	329969	DOOR CATCH, LOWER, 14"	1
---	330433	DOOR CATCH, LOWER, 19"	1
25	330453	DOOR STOP, LOWER, 30"	1
25	330454	DOOR STOP, LOWER, 14"	1
25	330455	DOOR STOP, LOWER, 19"	1
26	330480	DOOR, LOWER INSULATED, 30"	1
---	330481	DOOR, LOWER INSULATED, 19"	1
---	330482	DOOR, LOWER INSULATED, 14"	1
27	330498	DOOR UPPER INSULATED, 30"	1
---	330499	DOOR UPPER INSULATED, 19"	1
---	330500	DOOR UPPER INSULATED, 14"	1
28	330525	BRACKET, DOOR CATCH, 30"	1
---	330550	BRACKET, DOOR CATCH, 14"/19"	1
29	330526	HOOK, DOOR CATCH, UPPER DOOR, 30"	1
---	330548	HOOK, DOOR CATCH, UPPER DOOR, 14"/19"	1
30	330527	STOP, DOOR CATCH, 30"	1
---	330540	STOP, DOOR CATCH, 14"/19"	1
31	330528	HOOK, DOOR CATCH, LOWER DOOR, 30"	1
---	330546	HOOK, DOOR CATCH, LOWER DOOR, 14"/19"	1
32	330537	BRACKET, SAFETY DOOR	1
33	330539	ARM, SAFETY CATCH	1
34	330552	BRACKET, DOOR SWITCH, HOLD-DOWN	1

Swing-Out Door Assembly B30 R-L/ E2 L-R

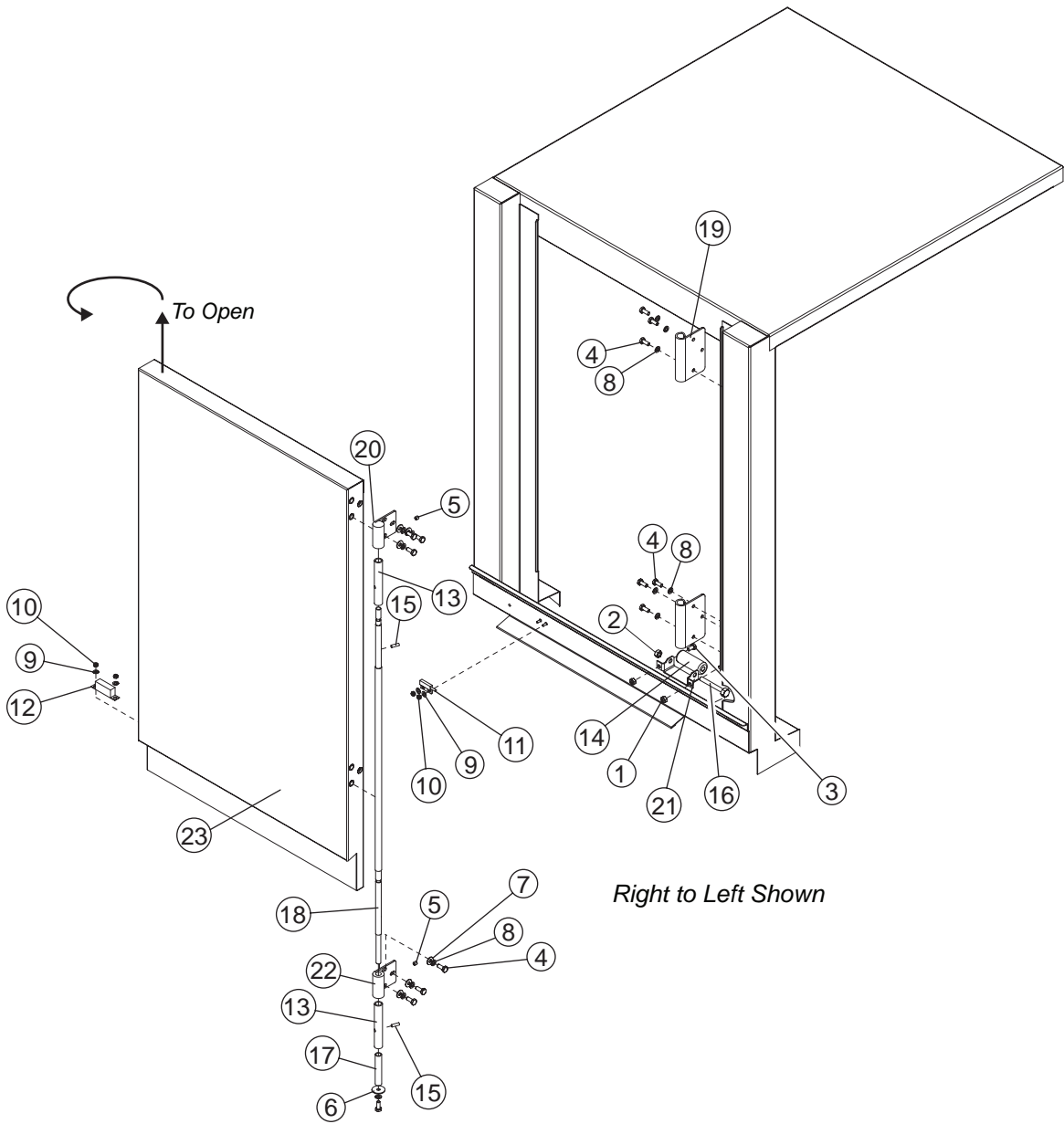



Item No.	Part No.	Description	Qty.
1	100141	Hex Grip Nut, 1/4-20 SST Ctr. Lock	2
2	100142	Hex Grip Nut, 5/16-18 SST Ctr. Lock	1
3	100734	Bolt, Hex Hd., 1/4-20 x 1/2" SST	2
4	100735	Bolt, Hex Hd., 1/4-20 x 5/8" SST	13
5	100771	Set Screw, 1/4-20 x 1/4" Lg. Cup Point SST	2
6	104925	Washer, Flat 1/4" x 1" x .06" SST	1
7	106026	Washer, Flat 1/4" x 5/8" x .06" SST	6
8	106482	Washer, Lock 1/4" Split Lock SST	13
9	107033	Washer, Flat, .208" x .438" x .03" SST	4
10	108954	Hex Grip Nut, 6-32 SST w/nylon	4
11	113719	Reed Switch, Aleph	1
12	113937	Magnet, Reed Switch	1
13	114705	Bushing, Door Pin, Hinged Door	2
14	114706	Roller, Door Closure, Swing-out Door	1
15	114826	Pin, Spiral, .187" Dia. x .625" Lg.	2
16	114827	Bolt, Hex HD., 5/16" x 3" SST	1
17	207003	Tube, 1/2" OD x 2-3/4" Lg.	1
18	207004	Rod, Door Pivot, Single EUC Swing-out Door	1
19	333324	Hinge, Flag Hood Side, Swing-out Door	2
20	333325	Hinge, Weldment, RH Top Swing-out Door	1
21	333327	Bracket, Door Roller, Swing-out Door	1
22	333537	Hinge Weldment, Swing-out, Bottom	1
23	333810	Door Weldment, B30 RL Hinge, Swing-out Insulated	1
---	xxxxxx	Door Weldment, B30 RL Hinge, Swing-out Standard	1
---	xxxxxx	Door Weldment, E2 LR Hinge, Swing-out Insulated	1
---	xxxxxx	Door Weldment, E2 LR Hinge, Swing-out Standard	1

Swing-Out Door Assembly E2 R-L /B30 L-R

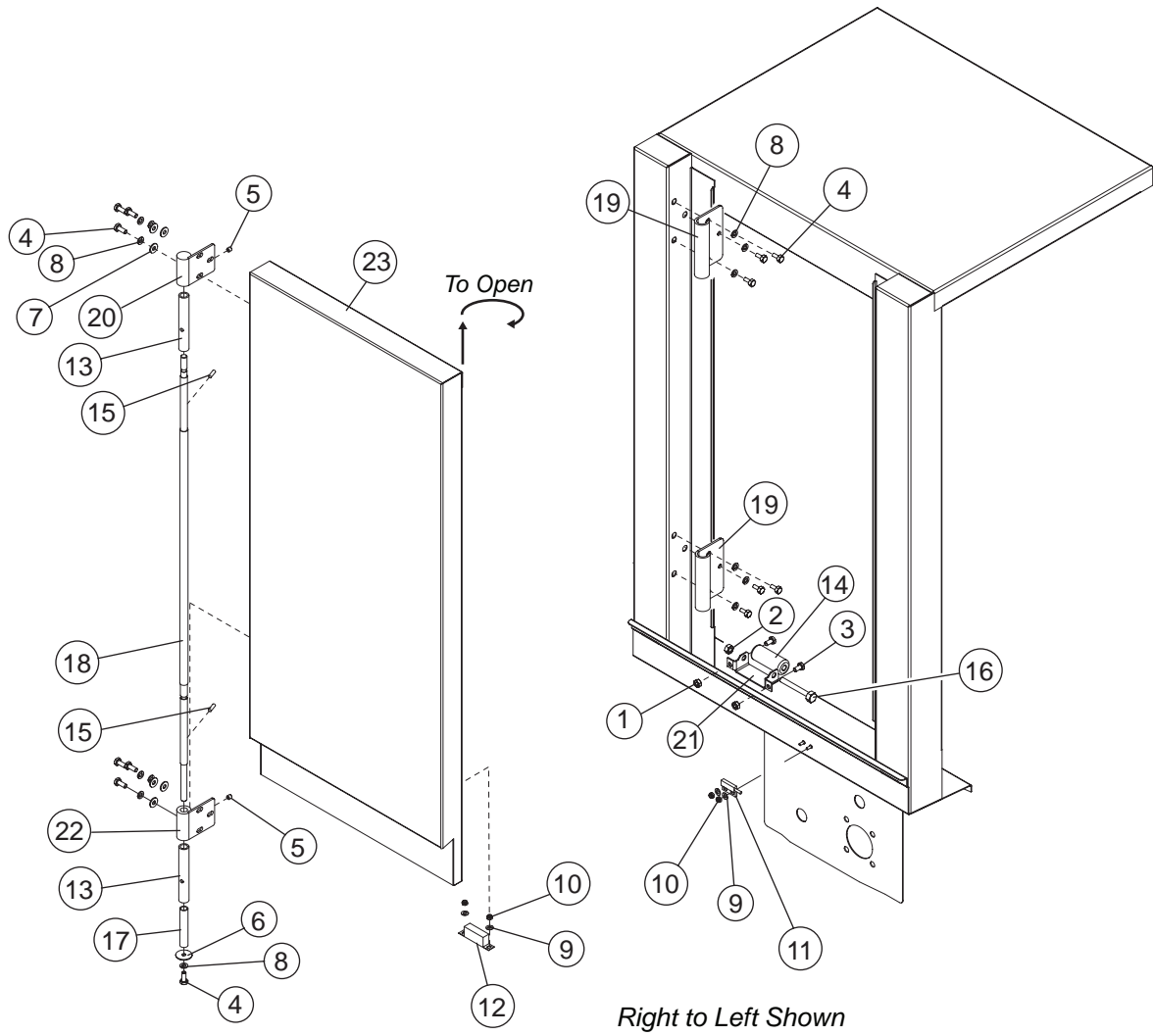

Item No.	Part No.	Description	Qty.
1	100141	Hex Grip Nut, 1/4-20 SST Ctr. Lock	2
2	100142	Hex Grip Nut, 5/16-18 SST Ctr. Lock	1
3	100734	Bolt, Hex Hd., 1/4-20 x 1/2" SST	2
4	100735	Bolt, Hex Hd., 1/4-20 x 5/8" SST	13
5	100771	Set Screw, 1/4-20 x 1/4" Lg. Cup Point SST	2
6	104925	Washer, Flat 1/4" x 1" x .06" SST	1
7	106026	Washer, Flat 1/4" x 5/8" x .06" SST	6
8	106482	Washer, Lock 1/4" Split Lock SST	13
9	107033	Washer, Flat, .208" x .438" x .03" SST	4
10	108954	Hex Grip Nut, 6-32 SST w/nylon	4
11	113719	Reed Switch, Aleph	1
12	113937	Magnet, Reed Switch	1
13	114705	Bushing, Door Pin, Hinged Door	2
14	114706	Roller, Door Closure, Swing-out Door	1
15	114826	Pin, Spiral, .187" Dia. x .625" Lg.	2
16	114827	Bolt, Hex HD., 5/16" x 3" SST	1
17	207003	Tube, 1/2" OD x 2-3/4" Lg.	1
18	207004	Rod, Door Pivot, Single EUC Swing-out Door	1
19	333324	Hinge, Flag Hood Side, Swing-out Door	2
20	333326	Hinge, Weldment, LH Top Swing-out Door	1
21	333327	Bracket, Door Roller, Swing-out Door	1
22	333537	Hinge Weldment, Swing-out, Bottom	1
23	333825	Door Weldment, E2 LH Hinge, Swing-out Insulated	1
---	xxxxxx	Door Weldment, E2 LH Hinge, Swing-out Standard	1
---	xxxxxx	Door Weldment, B30 RH Hinge, Swing-out Insulated	1
---	xxxxxx	Door Weldment, B30 RH Hinge, Swing-out Standard	1

Swing-Out Door Assembly C4

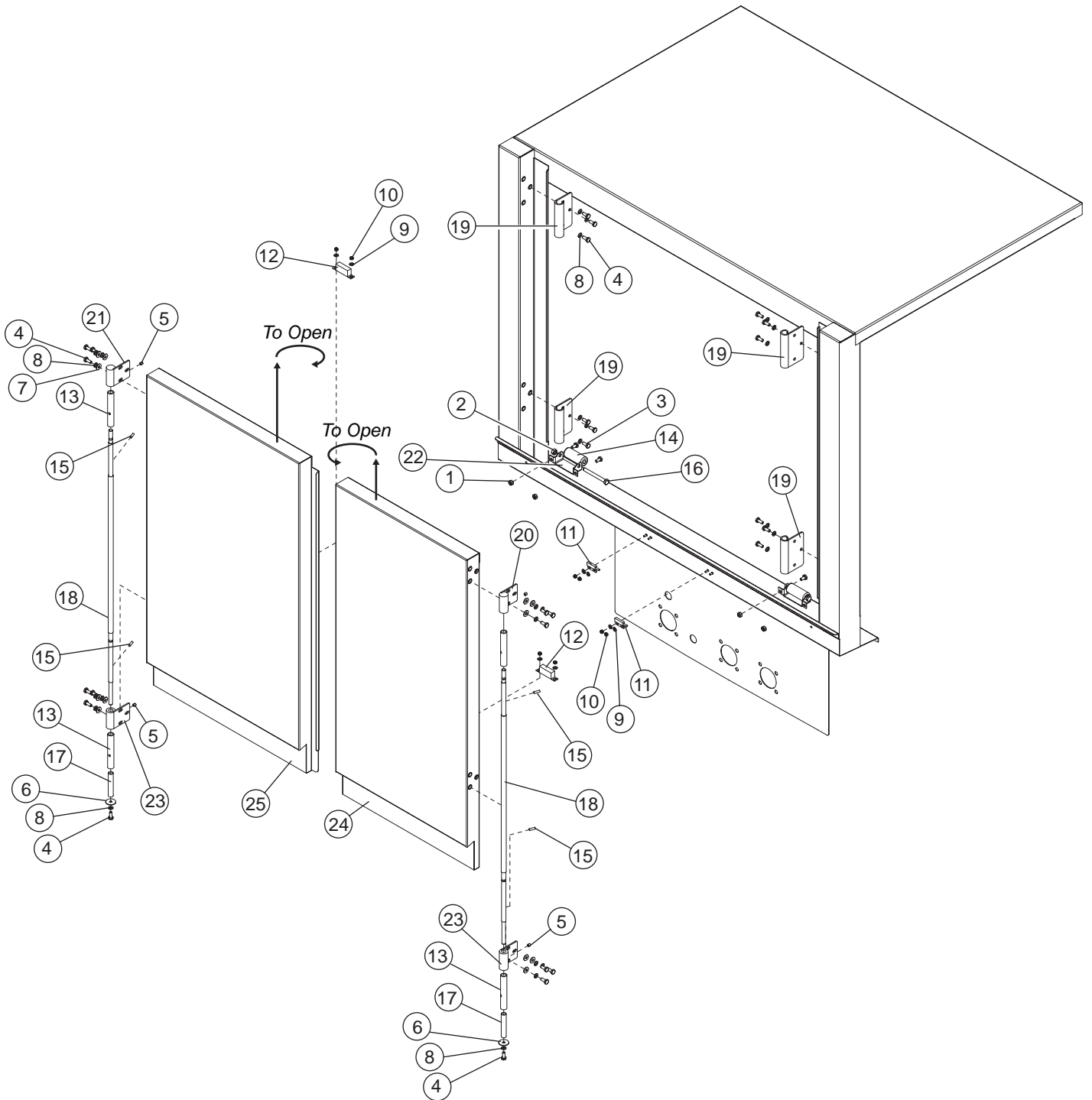

Item No.	Part No.	Description	Qty.
1	100141	Hex Grip Nut, 1/4-20 SST Ctr. Lock	4
2	100142	Hex Grip Nut, 5/16-18 SST Ctr. Lock	2
3	100734	Bolt, Hex Hd., 1/4-20 x 1/2" SST	4
4	100735	Bolt, Hex Hd., 1/4-20 x 5/8" SST	26
5	100771	Set Screw, 1/4-20 x 1/4" Lg. Cup Point SST	4
6	104925	Washer, Flat 1/4" x 1" x .06" SST	2
7	106026	Washer, Flat 1/4" x 5/8" x .06" SST	12
8	106482	Washer, Lock 1/4" Split Lock SST	26
9	107033	Washer, Flat, .208" x .438" x .03" SST	8
10	108954	Hex Grip Nut, 6-32 SST w/nylon	8
11	113719	Reed Switch, Aleph	2
12	113937	Magnet, Reed Switch	2
13	114705	Bushing, Door Pin, Hinged Door	4
14	114706	Roller, Door Closure, Swing-out Door	2
15	114826	Pin, Spiral, .187" Dia. x .625" Lg.	4
16	114827	Bolt, Hex HD., 5/16" x 3" SST	2
17	207003	Tube, 1/2" OD x 2-3/4" Lg.	2
18	207004	Rod, Door Pivot, Single EUC Swing-out Door	2
19	333324	Hinge, Flag Hood Side, Swing-out Door	4
20	333225	Hinge Weldment, RH, Top Swing-out Door	1
21	333326	Hinge, Weldment, LH Top Swing-out Door	1
22	333327	Bracket, Door Roller, Swing-out Door	2
23	333537	Hinge Weldment, Swing-out, Bottom	2
24	333819	Door Weldment, C4 RH Hinge, Swing-out Insulated	1
---	xxxxxx	Door Weldment, C4 RH Hinge, Swing-out Standard	1
25	333822	Door Weldment, C4 LH Hinge, Swing-out Insulated	1
---	xxxxxx	Door Weldment, C4 LH Hinge, Swing-out Standard	1

Scrap Screens

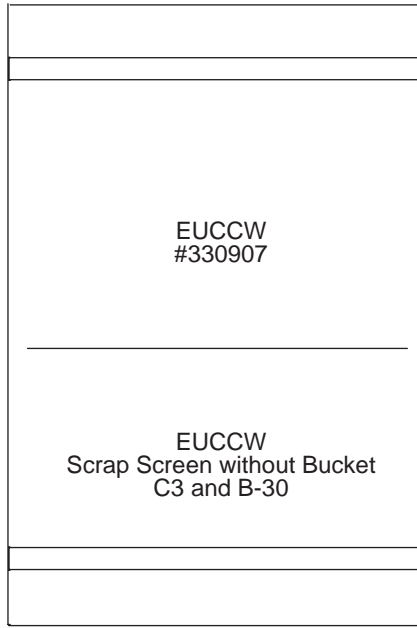

EUCCW  
#330907

EUCCW  
Scrap Screen without Bucket  
C3 and B-30

P/N 330213

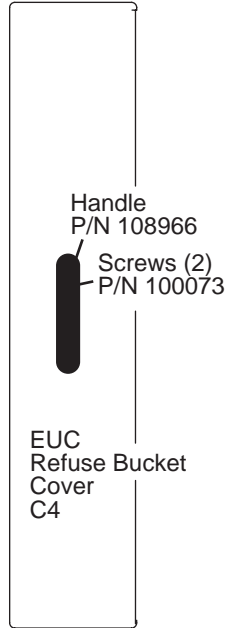

Handle  
P/N 108966  
Screws (2)  
P/N 100073

EUC  
Refuse Bucket  
Cover  
C4

P/N 329109

B4/C4  
#329109

B-30/C3  
#330187

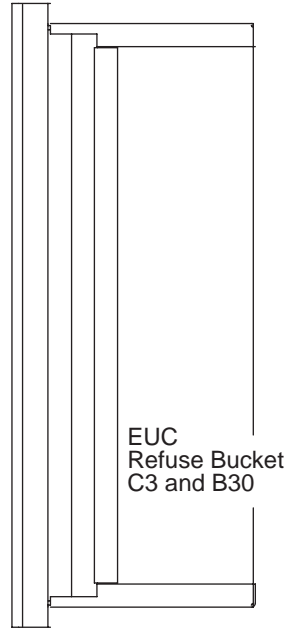

EUC  
Refuse Bucket  
C3 and B30

P/N 330188

C3/B-30  
#330188

B4/C4  
#329643

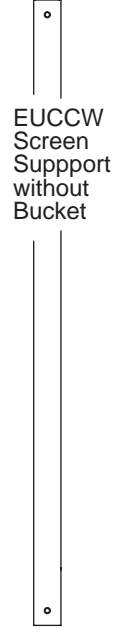

EUCCW  
Screen  
Support  
without  
Bucket

P/N 329113

EUC  
#330739



EUCCW  
Screen  
Support  
with  
Bucket

P/N 329115

EUC  
#330741

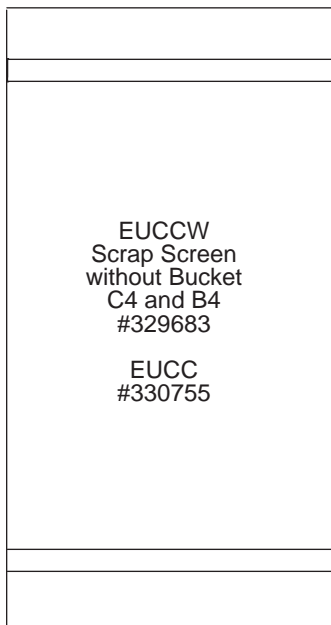

EUCCW  
Scrap Screen  
without Bucket  
C4 and B4  
#329683

EUC  
#330755

P/N 329683

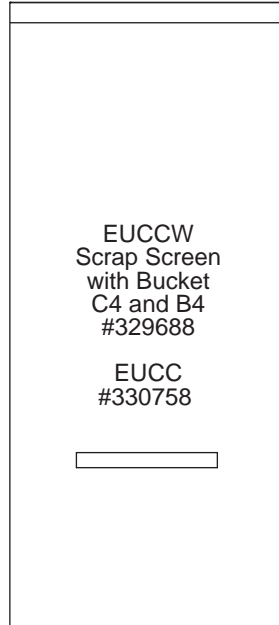

EUCCW  
Scrap Screen  
with Bucket  
C4 and B4  
#329688

EUC  
#330758

P/N 329688

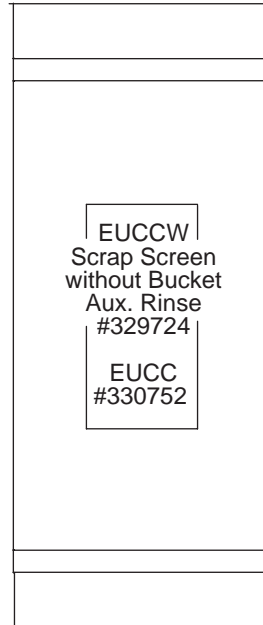

EUCCW  
Scrap Screen  
without Bucket  
Aux. Rinse  
#329724

EUC  
#330752

P/N 329724

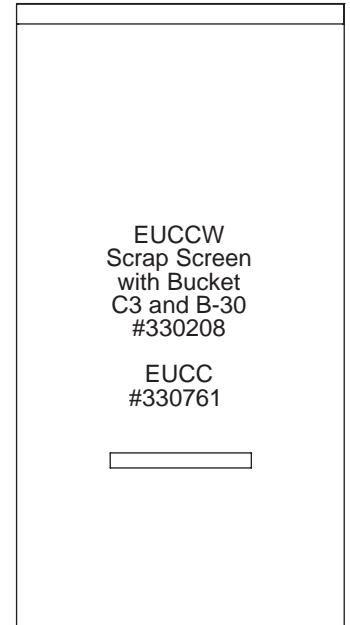

EUCCW  
Scrap Screen  
with Bucket  
C3 and B-30  
#330208

EUC  
#330761

P/N 330208

PART NO. 416688 REV. A

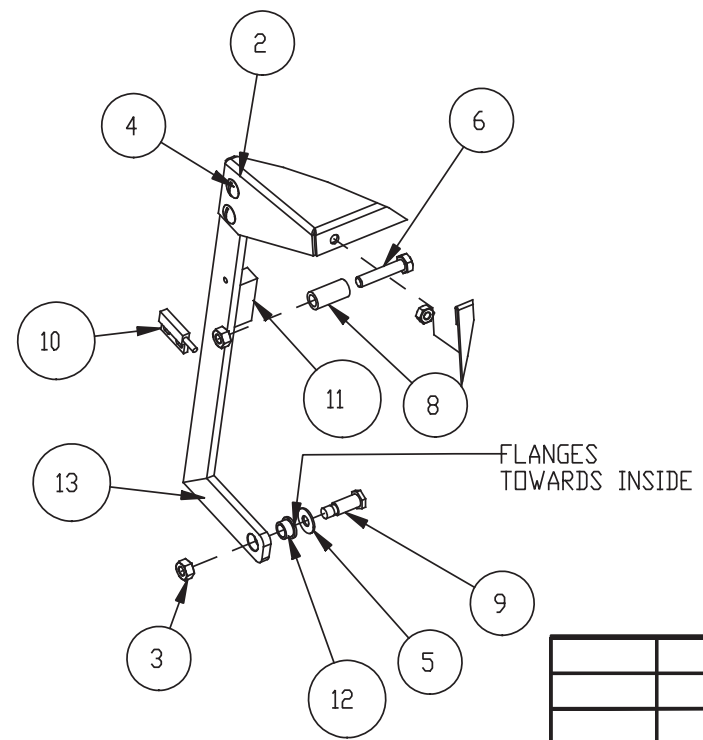
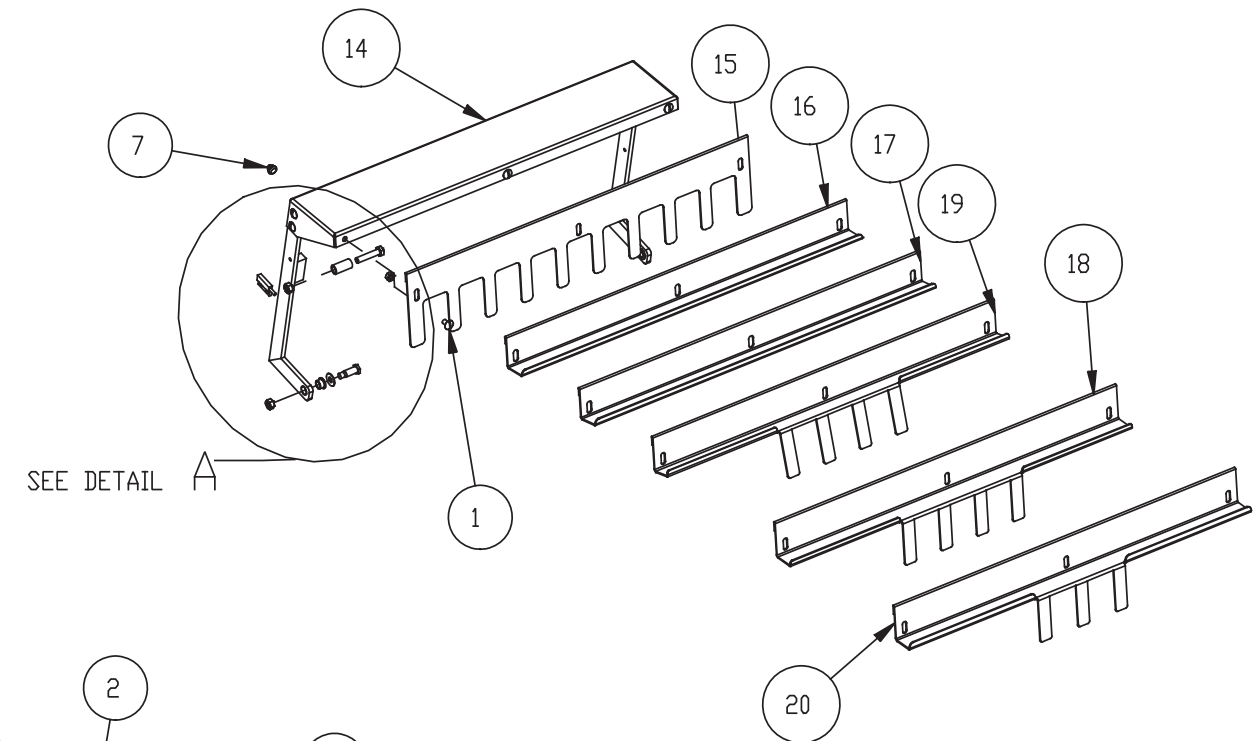
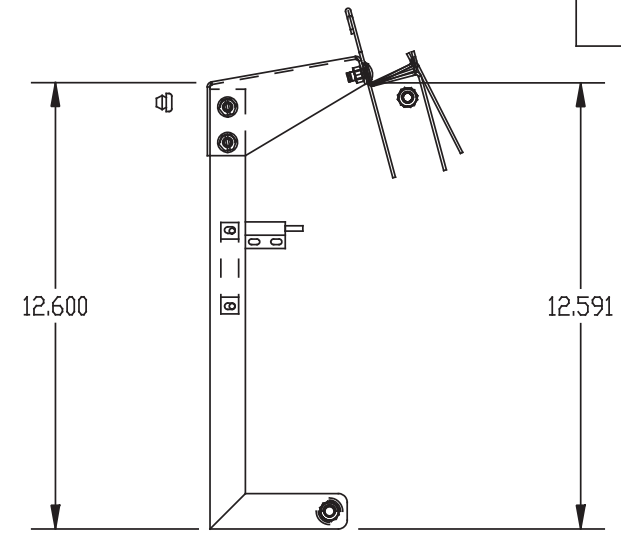

NOTE: SOME PARTS TO BE ASSEMBLED AT TIME OF MAIN ASSEMBLY

DETAIL A SCALE 0.188

THIS IS A PRO/ENGINEER DRAWING, DO NOT ALTER WITH PENCIL OR AUTOCAD

20	334639	FINGERS,SHUT-OFF, LONG/SHORT,TRAY,RL/LR,SHEET PAN, EUCC	1
19	333559-D3	FINGERS,SHUT-OFF, LONG/SHORT,PEG,RL/LR,SHEET PAN,EUCC W/D3	1
18	333559	FINGERS,SHUT-OFF, LONG/SHORT,PEG,RL/LR,SHEET PAN, EUCC	1
17	332601-D3	FINGER,SHORT,SHUT-OFF SHELF,EUCC W/D3-D4	1
16	332601	FINGER,SHORT,SHUT-OFF SHELF, EUCC	1
15	332065	SWITCH SHUT-OFF FINGERS LONG, EUCC	1
14	330709	SHELF WELD,CONVEYOR SHUT-OFF,EUCC	1
13	330070	ARM WELD,CONVEYOR SHUTOFF SHELF	2
12	114162	BEARING, FLANGE, BRONZE, DILITE TYPE	2
11	113937	MAGNET, REED SWITCH	1
10	113719	REED SWITCH, ALEPH	1
9	113692	SCREW, 3/8 X .750 X 5/16-18 SHOULDER	1
8	108377	SPACER,CONVEYOR BELT,17/32 OD X 11/32 ID X 1 3/32 LG. (GRAY)	1
7	107893	SHOCK ABSORBER	1
6	104002	CAP SCREW,HEX HEAD,5/16-18 X 1 1/2 SST	1
5	102376	WASHER,FLAT,5/16x3/4x.05 SST	1
4	100779	SCREW,TRUSS HEAD,1/4-20 x 5/8 SST	4
3	100142	HEX GRIP NUT, 5/16-18 SST, CTR LOCK	2
2	100141	HEX GRIP NUT,1/4-20 SST,CTR LOCK	7
1	100073	SCREW,TRUSS HEAD,1/4-20 x 1/2 SST	3
ITEM	PART #	DESCRIPTION	QTY

REV.	DESCRIPTION	ECN	DATE	BY
A	ADDED FINGERS		6/10/14	ML

SHIP TOLERANCES  
 UNLESS OTHERWISE NOTED  
 X.X ± 0.1"  
 X.XX ± 0.01"  
 X.XXX ± 0.005"  
 FRAC. ± 1/64"  
 ANGULAR ± 0.30"  
 ALL DIM. ARE IN INCHES

THIS DRAWING IS THE PROPERTY OF AND SHALL NOT BE REPRODUCED FOR ANY PURPOSE WITHOUT THE CONSENT OF CHAMPION INDUSTRIES

**Champion**  
 The Dishwashing Machine Specialists

DR. BY: TJ DATE: 09-Oct-08

TITLE: SHELF ASSEMBLY,CONVEYOR SHUT-OFF,EUCC

EUCC

416688 REV. A

SCALE: 0.094 SHEET 1 OF 1

PART NO. \_\_\_\_\_ REV. \_\_\_\_\_

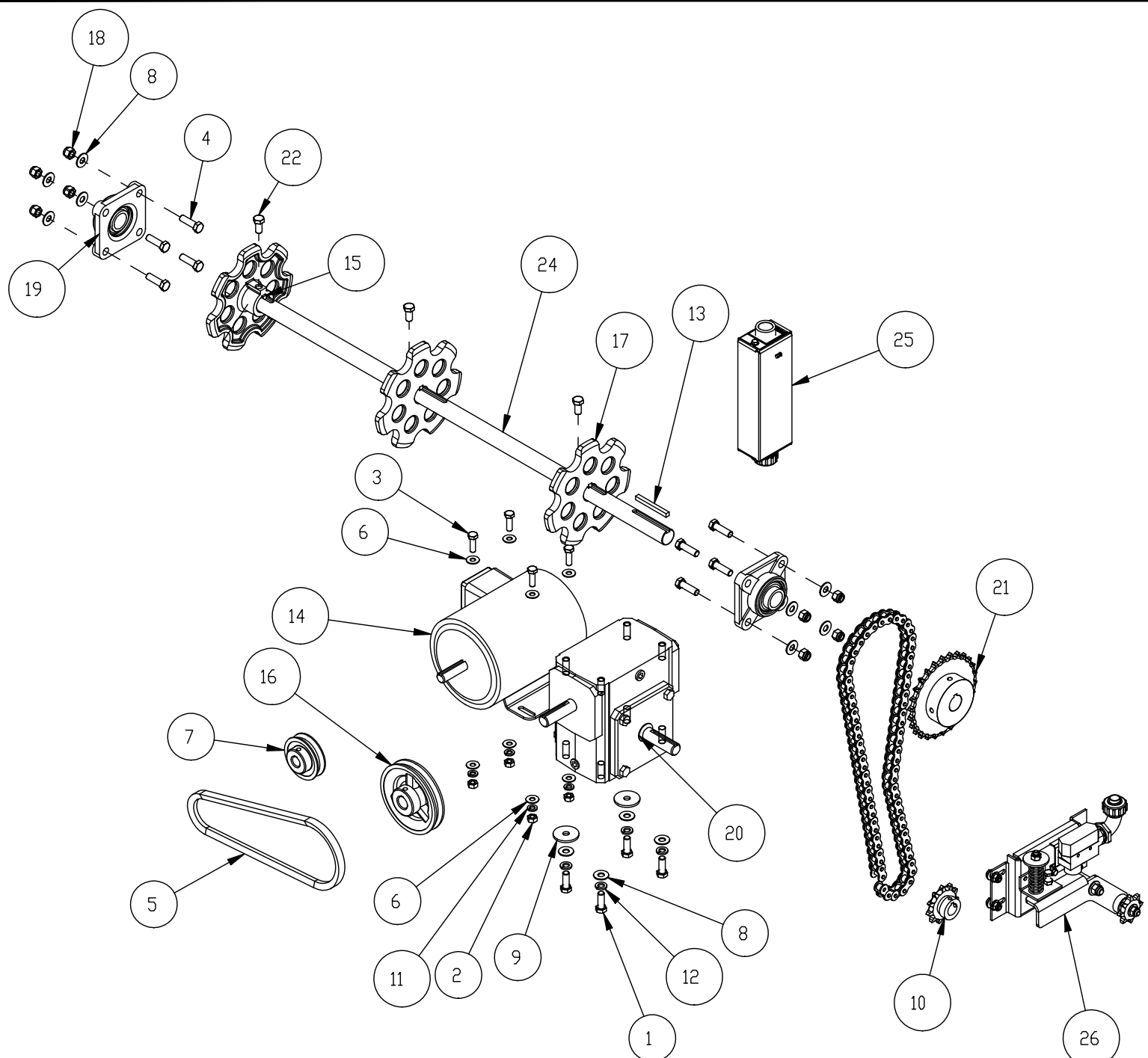

26	453522	SWITCH INSTALL, ANTI-JAM/TENSIONER, LR	1
25	418684-LR	BOX ASSY, REVERSE JOG SWITCH	1
24	330011	SHAFT, DRIVE, EUCCW	1
23	113970	SPROCKET,EUC CONVEYOR DRIVE	1
22	111480	CAP SCREW,HEX HEAD,3/8-16 X 3/4 SST,W/LOCTITE	3
21	111101	SPROCKET 50B26-11B0RE W/KEYWAY	1
20	110300-1	GEAR REDUCER,60:1,NO BRACKETS	1
19	109958	BEARING,4 BOLT,1",UC DRIVE	2
18	109010	HEX GRIP NUT,3/8-16 SST W/NYLON	8
17	108434	SPROCKET,CONVEYOR,UC MACHINE,MACHINED	3
16	108088	SHEAVE,AK46,3/4 BORE	1
15	107305	KEY 1/4 X 1/4 X 1 1/2 SST	3
14	107183	MOTOR, 1/2HP UC/CC DRIVE,MV 3PH	1
13	106679	KEY,1/4 X 1/4 X 2 1/2' LG,SST	1
12	106407	WASHER,LOCK,3/8 SPLIT,SST	4
11	106013	WASHER,LOCK,5/16 SPLIT,SST	4
10	105285	SPROCKET,50B11,3/4 BORE, W/KEY	1
9	104619	WASHER,FLAT,3/8x1 1/2x1/8 SST	2
8	104618	WASHER,FLAT,3/8x7/8x.06 SST	14
7	103163	SHEAVE,AK27,5/8 BORE	1
6	102376	WASHER,FLAT,5/16x3/4x.05 SST	8
5	100794	V-BELT,4L-310	1
4	100746	CAP SCREW,HEX HEAD,3/8-16 X 1 1/4 SST	8
3	100740	CAP SCREW,HEX HEAD,5/16-18 X 1 SST	4
2	100154	HEX PLAIN NUT,5/16-18 SST	4
1	100153	CAP SCREW,HEX HEAD,3/8-16 X 1 SST	4
ITEM	PART #	DESCRIPTION	QTY

THIS IS A PRO/ENGINEER DRAWING,  
DO NOT ALTER WITH PENCIL OR AUTOCAD

REV.	DESCRIPTION	ECN	DATE	BY

SHOP TOLERANCES  
UNLESS OTHERWISE NOTED  
X.X ± 0.1"  
X.XX ± 0.01"  
X.XXX ± 0.005"  
FRAC. ± 1/64"  
ANGULAR ± 0.30"  
ALL DIM. ARE IN INCHES

THIS DRAWING IS THE  
PROPERTY OF AND SHALL  
NOT BE REPRODUCED  
FOR ANY PURPOSE  
WITHOUT THE CONSENT OF  
CHAMPION INDUSTRIES

**Champion**  
The Dishwashing Machine Specialists

DR. BY: MLEFTWICH DATE: 06-Dec-06

TITLE: DRIVE INSTALLATION,LR,GENERIC  
EUCCW

SCALE: 1/8 SHEET 1 OF 1

REV. A



PART NO. 453522 REV. -

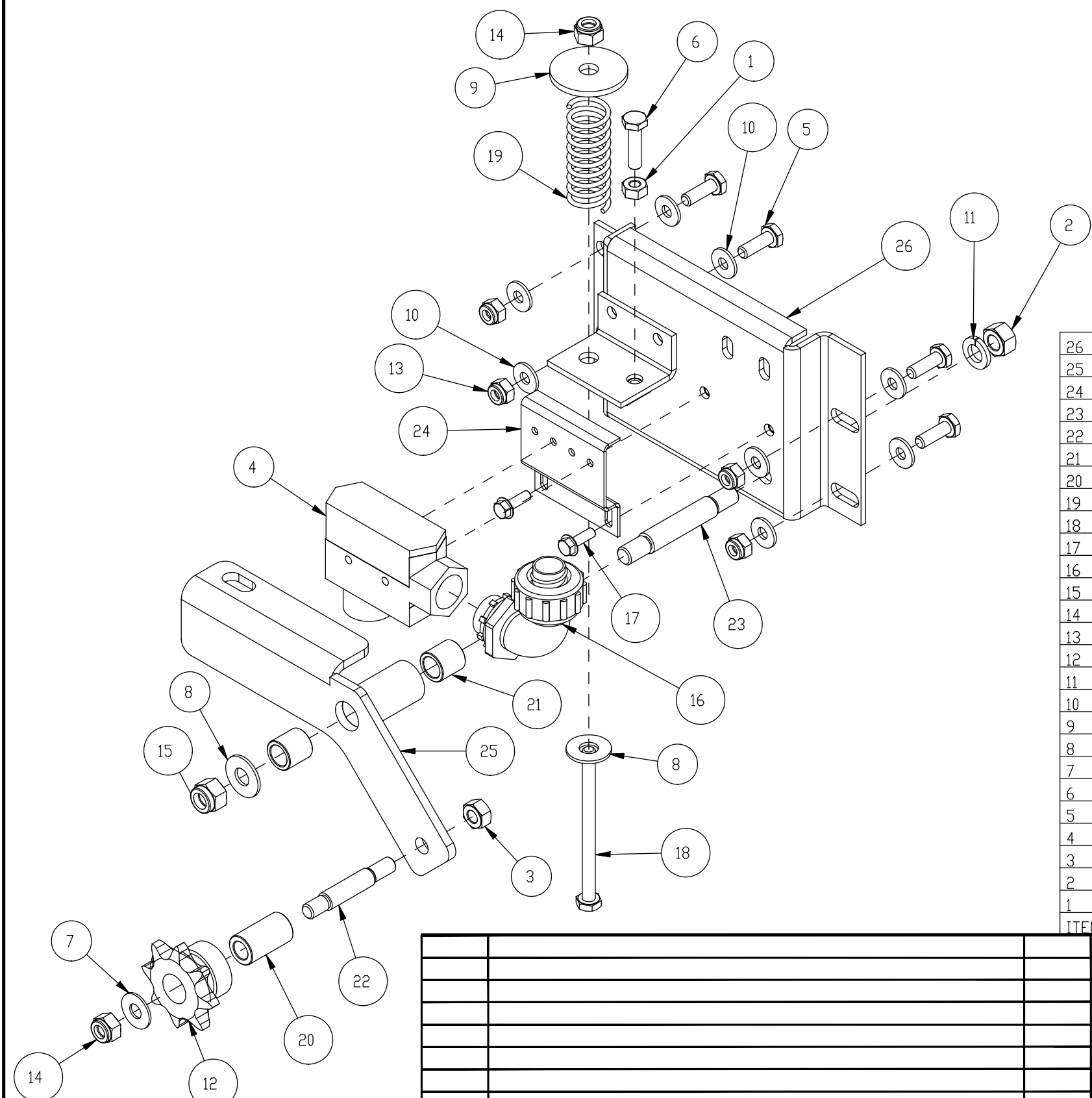

ITEM	PART #	DESCRIPTION	QTY
26	334180	BRACKET WELDMENT, CONVEYOR JAM SWITCH,LR	1
25	334179	ARM WELDMENT, CONVEYOR JAM SWITCH,LR	1
24	333892	BRACKET, SWITCH,CONVEYOR JAM	1
23	207061	POST, ARM, CONVEYOR JAM SWITCH	1
22	207060	POST, TENSIONER SPROCKET, CONVEYOR JAM SWITCH	1
21	114874	BUSHING,ARM, CONVEYOR JAM SWITCH	2
20	114871	BUSHING,SPROCKET, CONVEYOR JAM SWITCH	1
19	114857	SPRING, COMPRESSION, DRIVE TENSIONER, EUC LEE #LC 091K 05 S	1
18	113704	CAP SCREW HEX HEAD 5/16-18 X 3 1/2 SST	1
17	111370	CAP SCREW,HEX WASHER HEAD,10-32 X 5/8 SST	2
16	110837	ELBOW,1/2" CONDUIT,SEALTITE	1
15	109010	HEX GRIP NUT,3/8-16 SST W/NYLON	1
14	109009	HEX GRIP NUT, 5/16-18 SST W/NYLON	2
13	107967	HEX GRIP NUT,1/4-20 SST W/NYLON	4
12	106521	SPROCKET,50B8,5/8 BORE	1
11	106407	WASHER,LOCK,3/8 SPLIT,SST	1
10	106026	WASHER,FLAT,1/4x5/8x.06 SST	8
9	104619	WASHER,FLAT,3/8x1 1/2x1/8 SST	1
8	104618	WASHER,FLAT,3/8x7/8x.06 SST	2
7	102376	WASHER,FLAT,5/16x3/4x.05 SST	1
6	100738	CAP SCREW,HEX HEAD,1/4-20 X 1 SST	1
5	100736	CAP SCREW,HEX HEAD,1/4-20 X 3/4 SST	4
4	100352	LIMIT SWITCH,BUTTON TYPE	1
3	100142	HEX GRIP NUT, 5/16-18 SST, CTR LOCK	1
2	100140	HEX PLAIN NUT,3/8-16 SST	1
1	100003	HEX PLAIN NUT,1/4-20 SST	1

THIS IS A PRO/ENGINEER DRAWING,  
DO NOT ALTER WITH PENCIL OR AUTOCAD

REV.	DESCRIPTION	ECN	DATE	BY

**SHOP TOLERANCES**

UNLESS OTHERWISE NOTED  
X.X ± 0.1"  
X.XX ± 0.01"  
X.XXX ± 0.005"  
FRAC. ± 1/64"  
ANGULAR ± 0.30"  
ALL DIM. ARE IN INCHES

THIS DRAWING IS THE PROPERTY OF AND SHALL NOT BE REPRODUCED FOR ANY PURPOSE WITHOUT THE CONSENT OF CHAMPION INDUSTRIES

---

**Champion**  
The Dishwashing Machine Specialists

DR. BY: MLEFTWICH DATE: Jan-27-11  
TITLE: SWITCH INSTALL, ANTI-JAM/TENSIONER, LR  
EUC

**B** 453522 REV. -  
SCALE: 7/16 SHEET 1 OF 1

PART NO. 453521 REV. -

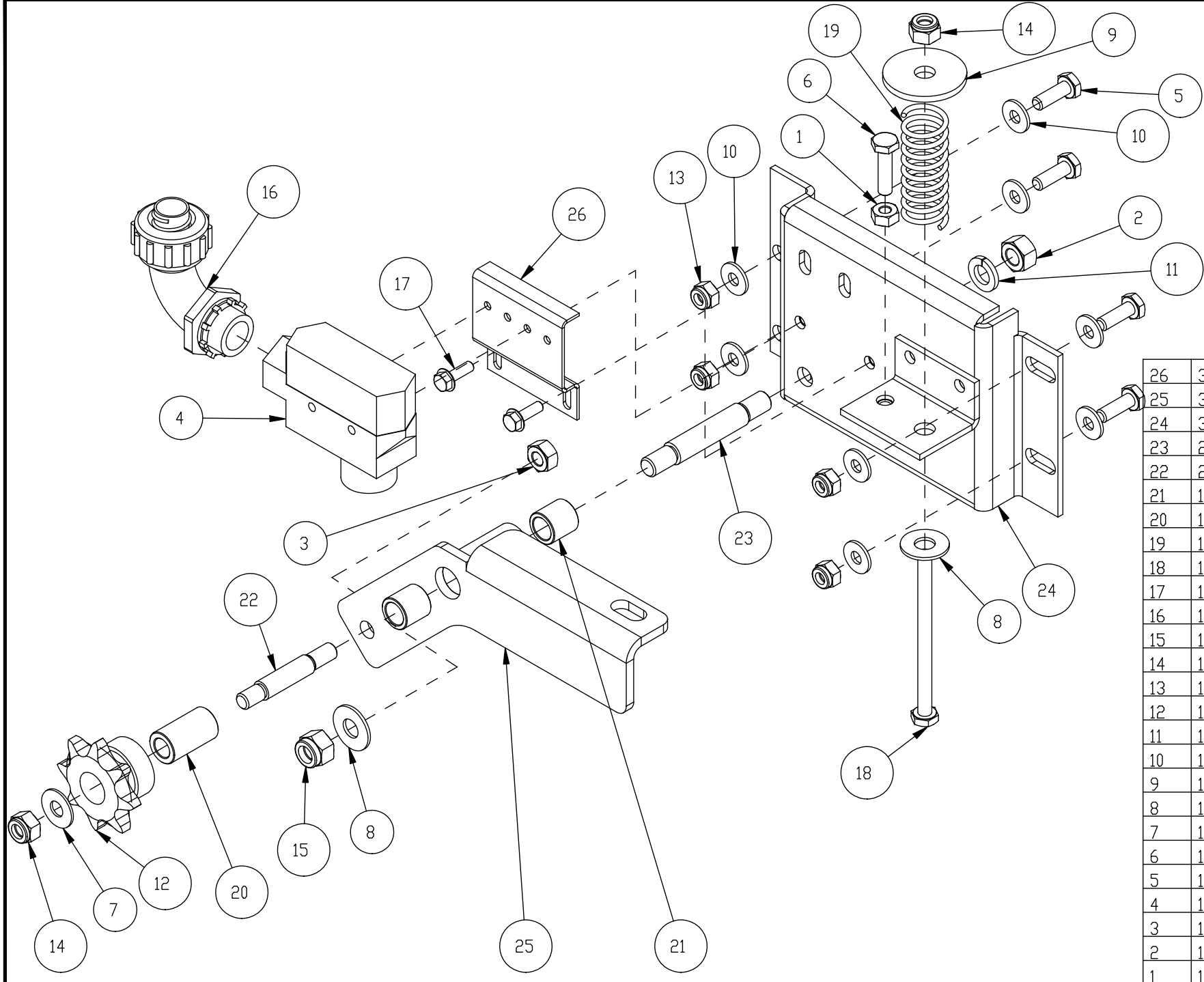

26	333892	BRACKET, SWITCH,CONVEYOR JAM	1
25	333891	ARM WELDMENT, CONVEYOR JAM SWITCH, RL	1
24	333888	BRACKET WELDMENT, CONVEYOR JAM SWITCH,RL	1
23	207061	POST, ARM, CONVEYOR JAM SWITCH	1
22	207060	POST, TENSIONER SPROCKET, CONVEYOR JAM SWITCH	1
21	114874	BUSHING,ARM, CONVEYOR JAM SWITCH	2
20	114871	BUSHING,SPROCKET, CONVEYOR JAM SWITCH	1
19	114857	SPRING, COMPRESSION, DRIVE TENSIONER, EUC LEE #LC 091K 05 S	1
18	113704	CAP SCREW HEX HEAD 5/16-18 X 3 1/2 SST	1
17	111370	CAP SCREW,HEX WASHER HEAD,10-32 X 5/8 SST	2
16	110837	EL.BOW,1/2" CONDUIT,SEALTITE	1
15	109010	HEX GRIP NUT,3/8-16 SST W/NYLON	1
14	109009	HEX GRIP NUT, 5/16-18 SST W/NYLON	2
13	107967	HEX GRIP NUT,1/4-20 SST W/NYLON	4
12	106521	SPROCKET,50B8,5/8 BORE	1
11	106407	WASHER,LOCK,3/8 SPLIT,SST	1
10	106026	WASHER,FLAT,1/4x5/8x.06 SST	8
9	104619	WASHER,FLAT,3/8x1 1/2x1/8 SST	1
8	104618	WASHER,FLAT,3/8x7/8x.06 SST	2
7	102376	WASHER,FLAT,5/16x3/4x.05 SST	1
6	100738	CAP SCREW,HEX HEAD,1/4-20 X 1 SST	1
5	100736	CAP SCREW,HEX HEAD,1/4-20 X 3/4 SST	4
4	100352	LIMIT SWITCH,BUTTON TYPE	1
3	100142	HEX GRIP NUT, 5/16-18 SST, CTR LOCK	1
2	100140	HEX PLAIN NUT,3/8-16 SST	1
1	100003	HEX PLAIN NUT,1/4-20 SST	1
ITEM	PART #	DESCRIPTION	QTY

THIS IS A PRO/ENGINEER DRAWING,  
DO NOT ALTER WITH PENCIL OR AUTOCAD

REV.	DESCRIPTION	ECN	DATE	BY

SHOP TOLERANCES  
 UNLESS OTHERWISE NOTED  
 X.X ± 0.1"  
 X.XX ± 0.01"  
 X.XXX ± 0.005"  
 FRAC. ± 1/64"  
 ANGULAR ± 0.30"  
 ALL DIM. ARE IN INCHES

THIS DRAWING IS THE  
 PROPERTY OF AND SHALL  
 NOT BE REPRODUCED  
 FOR ANY PURPOSE  
 WITHOUT THE CONSENT OF  
 CHAMPION INDUSTRIES

**Champion**  
 The Dishwashing Machine Specialists

DR. BY: M.LEFTWICH DATE: Jan-27-11

TITLE: SWITCH INSTALL,ANTI- JAM/TENSIONER, RL  
 EUC

B 453521 REV. -

SCALE: 7/16 SHEET 1 OF 1

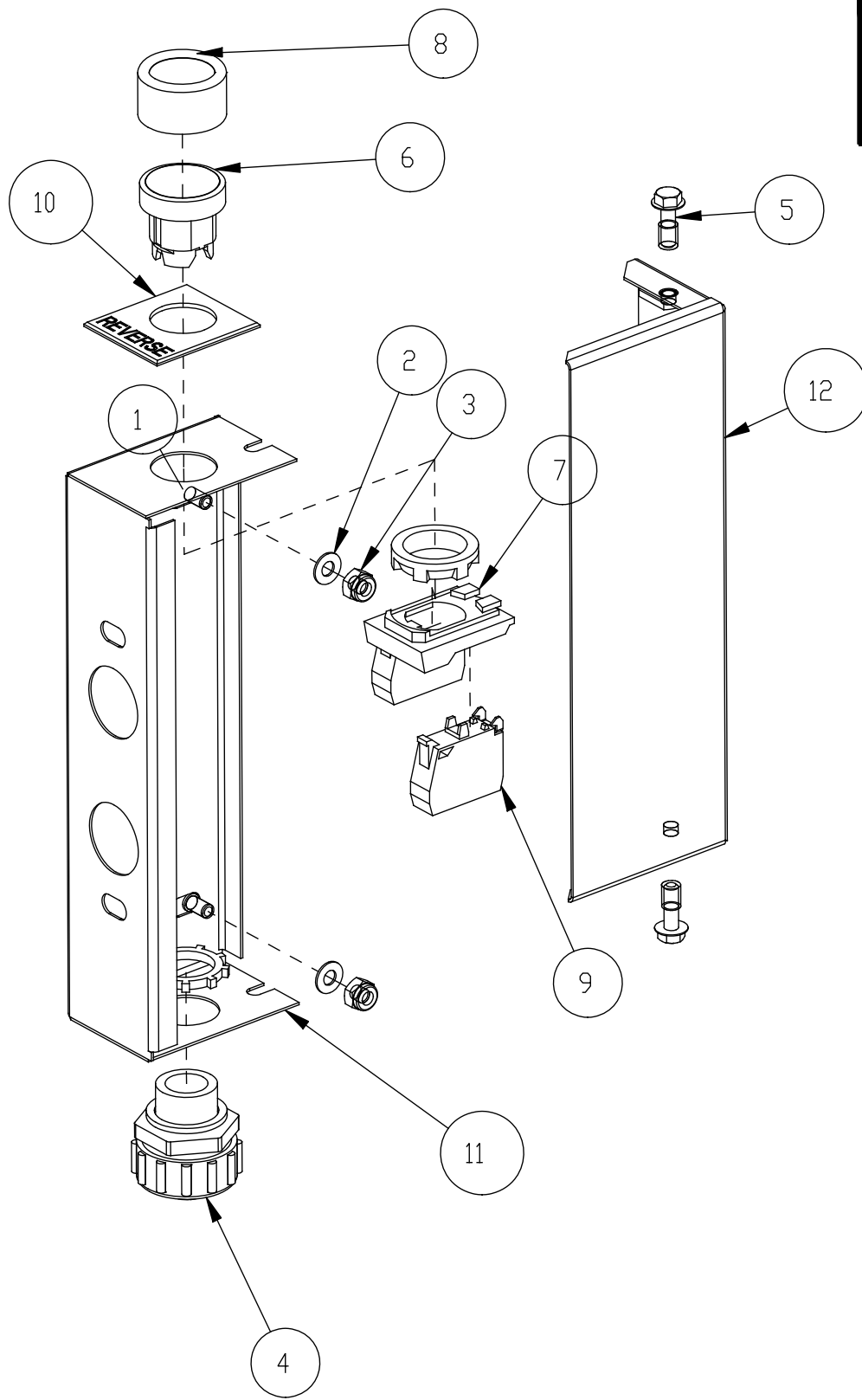

REVISIONS		A	418684	REV. A
REV.	DESCRIPTION	ECN	DATE	BY
A	CHANGED START/STOP BUTTON TYPE	12-005	2/24/12	ML

NOTE: R-L VERSION SHOWN,  
FOR L-R, REVERSE LOCATIONS OF BUTTON AND CONDUIT FITTING

12	334204	COVER WELD, START/STOP-REVERSE SWITCH	1
11	334203	<del>BOX</del> WELDMENT, START/STOP-REVERSE	1
10	114873	NAMEPLATE-REVERSE	1
9	113755	CONTACT,NC	1
8	113140	BOOT,PUSHBUTTON,22MM	1
7	111617	CONTACT BLOCK,NO W/MOUNTING BASE	1
6	111614	PUSHBUTTON ASSY,GREEN 22MM	1
5	111370	CAP SCREW,HEX WASHER HEAD,10-32 X 5/8 SST	2
4	110836	FITTING,STRAIGHT,1/2" SEALTITE	1
3	107966	HEX GRIP NUT,10-32 SST W/NYLON	2
2	107033	WASHER,FLAT,,208X.438X.03 SST	2
1	105695	WELD-STUD,10-32 X 3/8 LG.SST	2
ITEM	PART #	DESCRIPTION	QTY

SHOP TOLERANCES

UNLESS OTHERWISE NOTED  
 X.X ± 0.1"  
 X.XX ± 0.01"  
 X.XXX ± 0.005"  
 FRAC. ± 1/64"  
 ANGULAR ± 0.30°  
 ALL DIM. ARE IN INCHES

THIS DRAWING IS THE  
 PROPERTY OF AND SHALL  
 NOT BE REPRODUCED  
 FOR ANY PURPOSE  
 WITHOUT THE CONSENT OF  
 CHAMPION INDUSTRIES

**Champion**  
 The Dishwashing Machine Specialists

DR. BY: MLEFTWICH      DATE: May-31-11

TITLE: BOX ASSY, REVERSE JOG SWITCH  
 EUC/EEUC W/ANTI-JAM SWITCH

A 418684 REV. A

SCALE: 3/8      SHEET 1 OF 1

THIS IS A PRO/ENGINEER DRAWING,  
 DO NOT ALTER WITH PENCIL OR AUTOCAD

PART NO.

453494

REV.

-

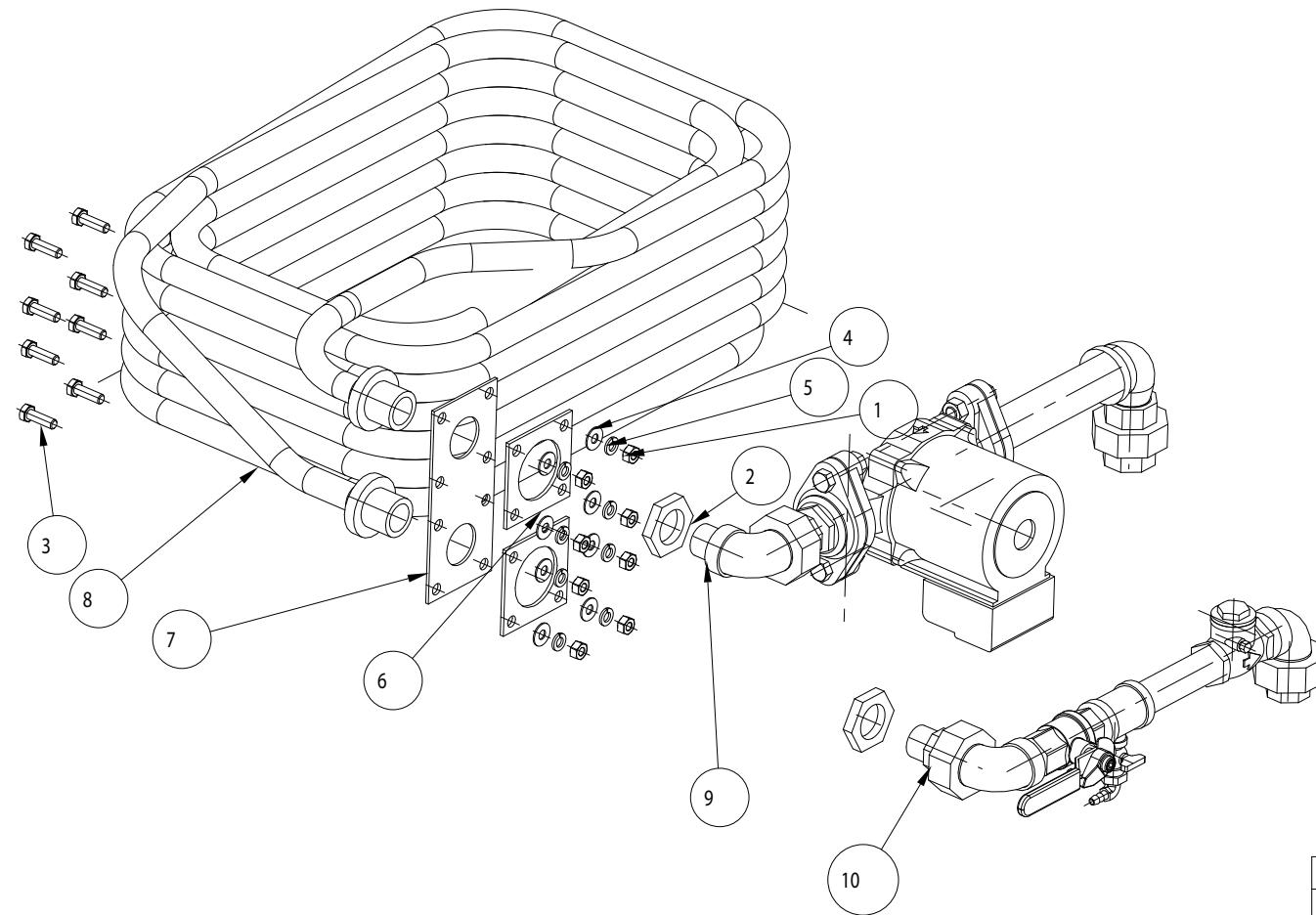

ITEM	PART #	DESCRIPTION	QTY
10	601876	PIPING ASSY,OUTLET,HWC,C4 EUCCW	1
9	601772	PIPING ASSY,WATER-IN,C4 HWC,NUCCW	1
8	333939	COIL WELDMNT,HOT WATER,C3,EUCCW	1
7	331799	PLATE,HOT WATER COIL MOUNTING	1
6	108345	GASKET,HEATER/STANDPIPE	2
5	106013	WASHER,LOCK,5/16 SPLIT,SST	8
4	102376	WASHER,FLAT,5/16x3/4x.05 SST	8
3	100740	CAP SCREW,HEX HEAD,5/16-18 X 1 SST	8
2	100585	LOCKNUT,1" NPT,BRASS	2
1	100154	HEX PLAIN NUT,5/16-18 SST	8

REV.	DESCRIPTION	ECN	DATE	BY

**SHOP TOLERANCES**

UNLESS OTHERWISE NOTED  
 X.X     .01"  
 X.XX    .001"  
 X.XXX   .0005"  
 FRAC.   1/64"  
 ANGULAR .030'  
 ALL DIM. ARE IN INCHES

THIS DRAWING IS THE PROPERTY OF AND SHALL NOT BE REPRODUCED FOR ANY PURPOSE WITHOUT THE CONSENT OF CHAMPION INDUSTRIES

**Champion**  
 The Dishwashing Machine Specialists

DR BY: M. LEFTWICH     DATE: 21-Sep-10

TITLE: HEAT SYSTEM,C3 HWCOIL  
 EUCCW

**B** | **453494**     REV. -

SCALE: 3/16     SHEET OF 1 1

THIS IS A PRO/ENGINEER DRAWING,  
 DO NOT ALTER WITH PENCIL OR AUTOCAD

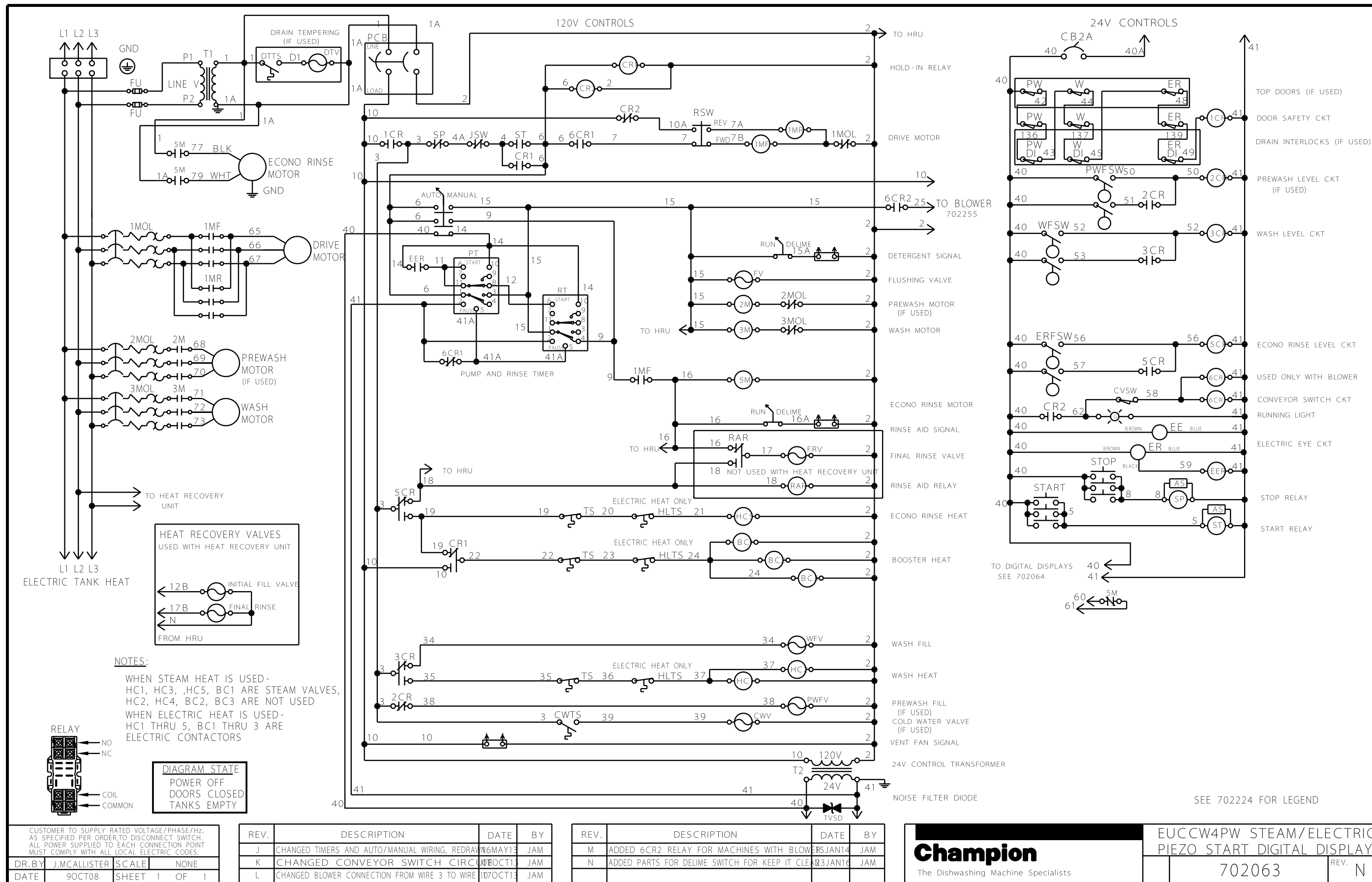

CUSTOMER TO SUPPLY RATED VOLTAGE/PHASE/HZ, AS SPECIFIED PER ORDER, TO DISCONNECT SWITCH. ALL POWER SUPPLIED TO EACH CONNECTION POINT MUST COMPLY WITH ALL LOCAL ELECTRIC CODES.

DR. BY	J.MCALLISTER	SCALE	NONE
DATE	9OCT08	SHEET	1 OF 1

REV.	DESCRIPTION	DATE	BY
J	CHANGED TIMERS AND AUTO/MANUAL WIRING, REDRAW	16MAY13	JAM
K	CHANGED CONVEYOR SWITCH CIRC.	08OCT13	JAM
L	CHANGED BLOWER CONNECTION FROM WIRE 3 TO WIRE 10	10OCT13	JAM

REV.	DESCRIPTION	DATE	BY
M	ADDED 6CR2 RELAY FOR MACHINES WITH BLOWER	15JAN14	JAM
N	ADDED PARTS FOR DELIME SWITCH FOR KEEP IT CLEAN	13JAN16	JAM



**EUCCW4PW STEAM/ELECTRIC PIEZO START DIGITAL DISPLAY**

702063 REV. N



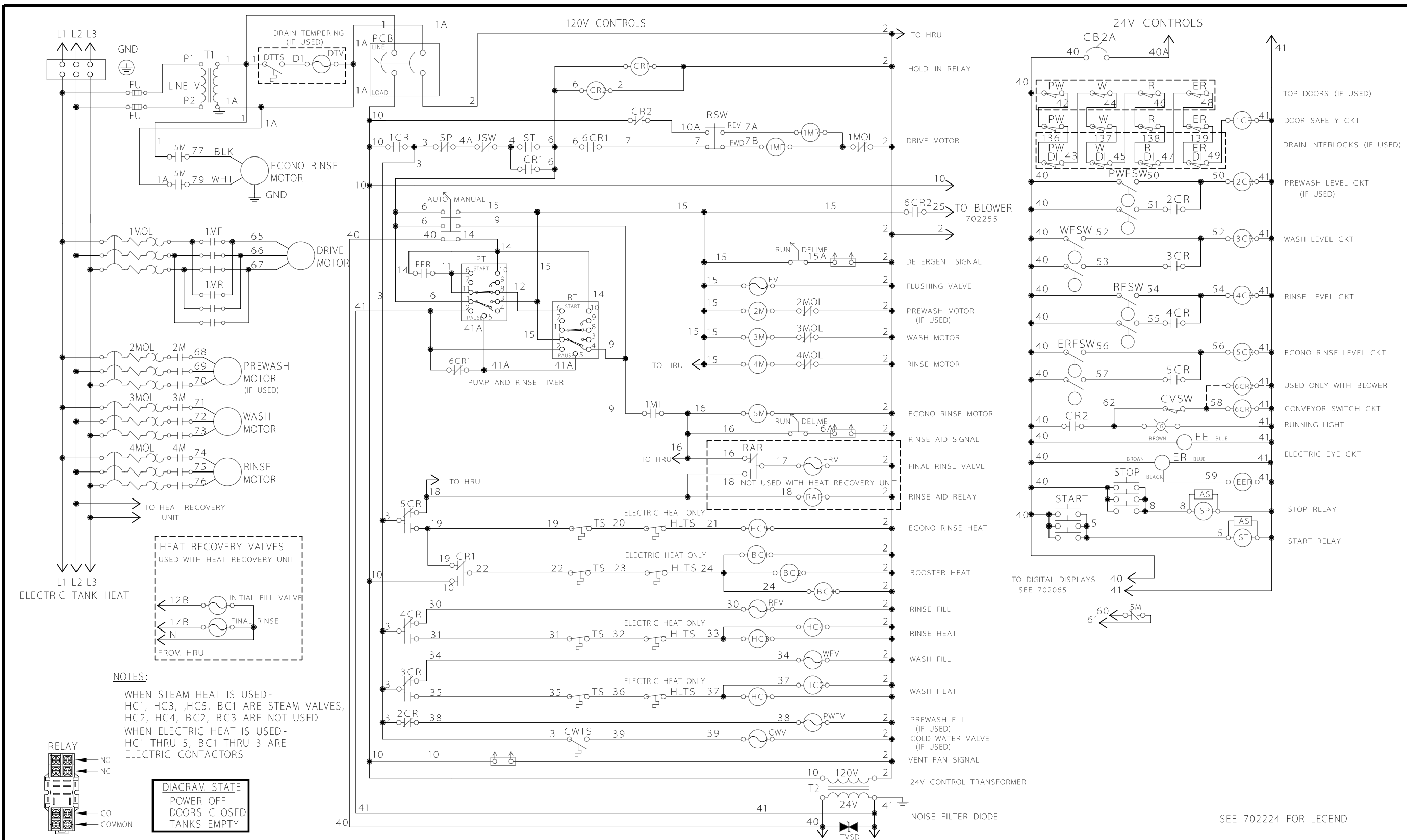

CUSTOMER TO SUPPLY RATED VOLTAGE/PHASE/Hz AS SPECIFIED PER ORDER, TO DISCONNECT SWITCH. ALL POWER SUPPLIED TO EACH CONNECTION POINT MUST COMPLY WITH ALL LOCAL ELECTRIC CODES.			
DR. BY	J.MCALLISTER	SCALE	NONE
DATE	5DEC08	SHEET	1 OF 1

REV.	DESCRIPTION	DATE	BY
J	CHANGED TIMERS AND AUTO/MANUAL WIRING, REDRAWN	16MAY13	JAM
K	CHANGED BLOWER CONNECTION FROM WIRE 3 TO WIRE 10	10OCT13	JAM
L	ADDED 6CR2 FOR MACHINES WITH BLOWER	09JAN14	JAM

REV.	DESCRIPTION	DATE	BY
M	ADDED PARTS FOR DELIME FOR KEEP IT CLEAN	23JAN16	JAM

**Champion**  
 The Dishwashing Machine Specialists

**EUCCW8PW STEAM/ELECTRIC DIGITAL DISPLAY**

**B** 702068 REV. M

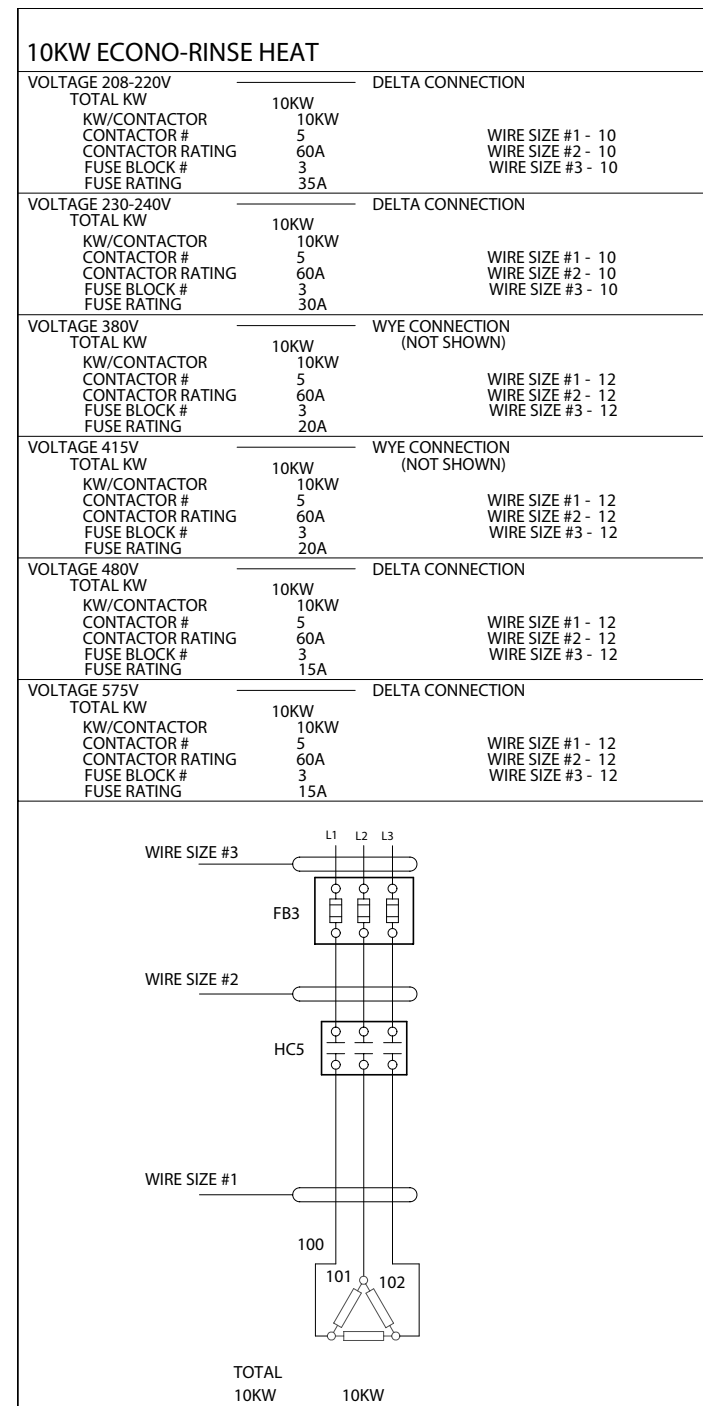
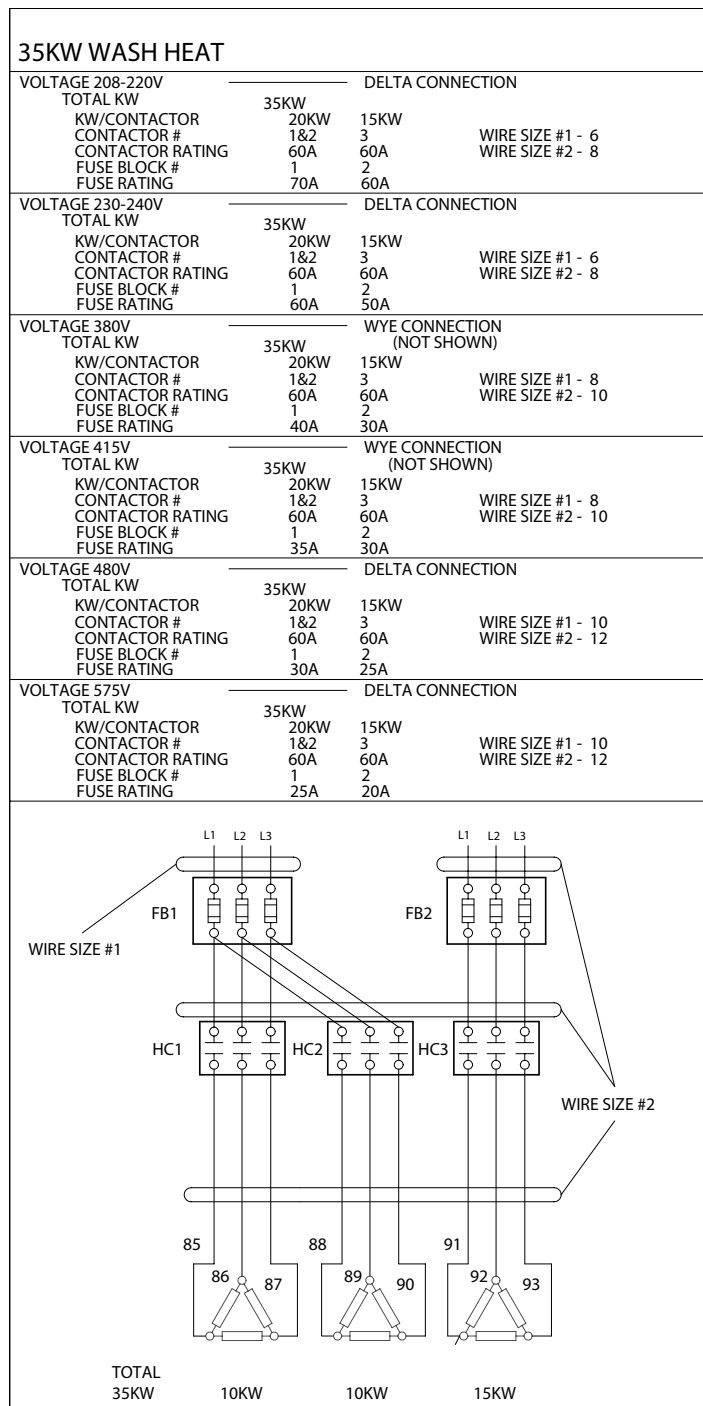
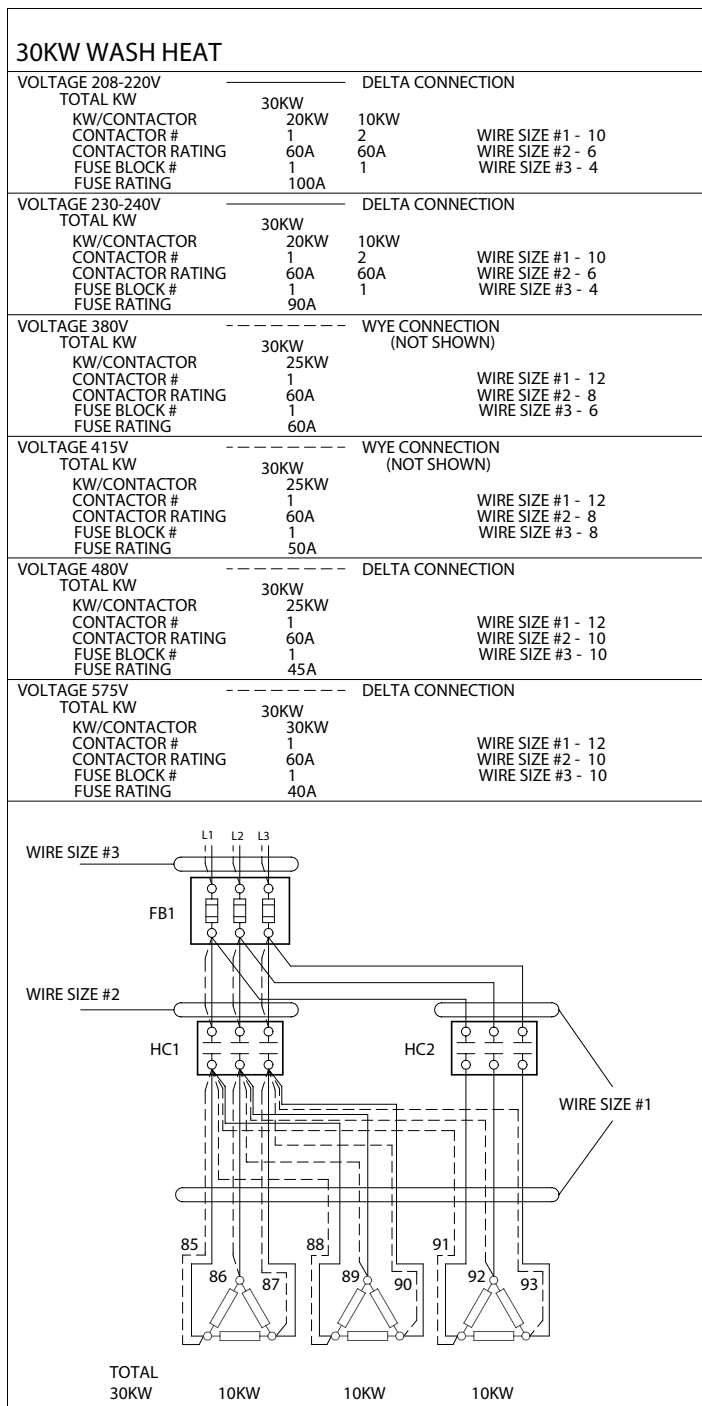

NOTES:  
 1. ON MODELS WITH MULTIPLE ELECTRIC CONNECTIONS, MAKE HEATER POWER CONNECTIONS AT THE HEATER FUSE BLOCK.

FB-	FUSE BLOCK
HC-	HEAT CONTACTOR

702784A

CUSTOMER TO SUPPLY RATED VOLTAGE/PHASE/HZ, AS SPECIFIED PER ORDER, TO DISCONNECT SWITCH. ALL POWER SUPPLIED TO EACH CONNECTION POINT MUST COMPLY WITH ALL LOCAL ELECTRIC CODES.			
DR.BY	J.MCALLISTER	SCALE	NONE
DATE	23SEP13	SHEET	1 OF 1

REV.	DESCRIPTION	DATE	BY

REV.	DESCRIPTION	DATE	BY

**Champion**  
 The Dishwashing Machine Specialists

EUCCW4 30/35KW WASH TANK HEAT		REV.
<b>B</b>	702784A	

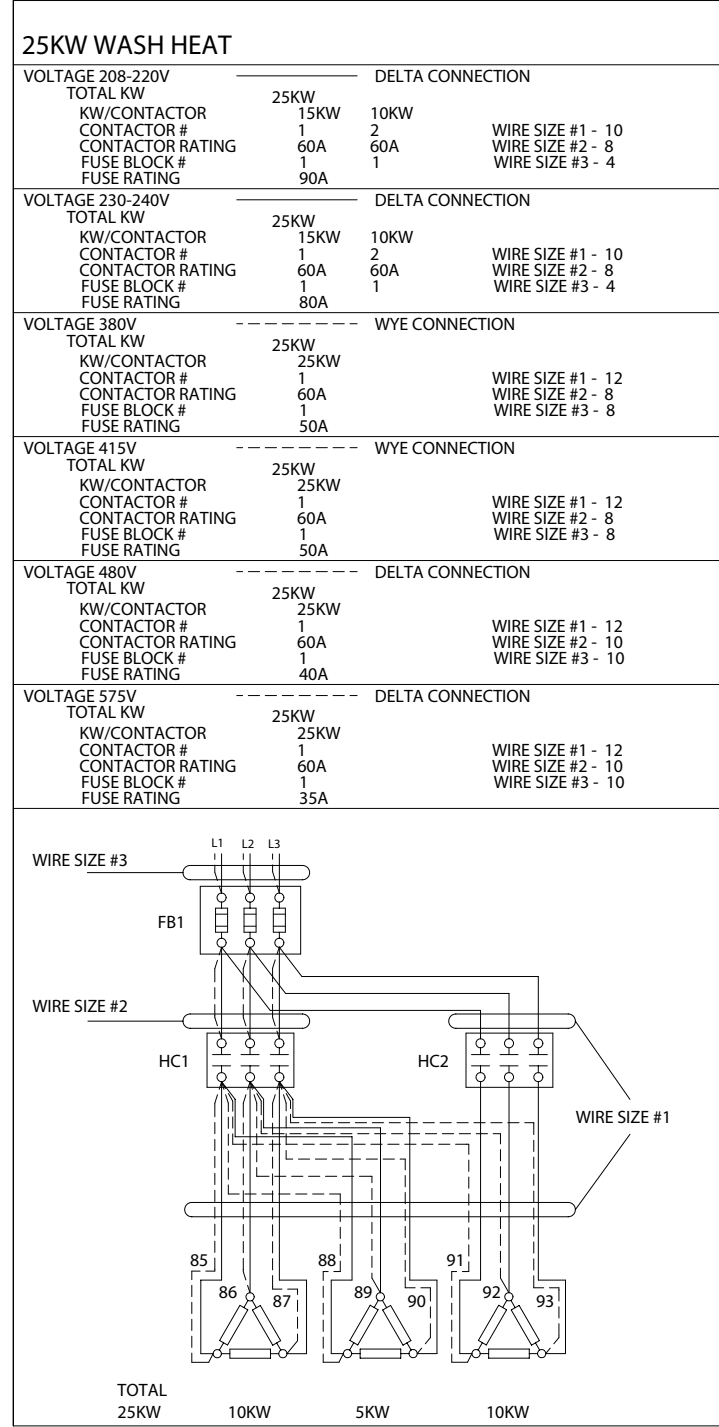

ON MODELS WITH TWO WASH TANKS SECOND TANK HAS WIRE NUMBERS 85A THRU 93A

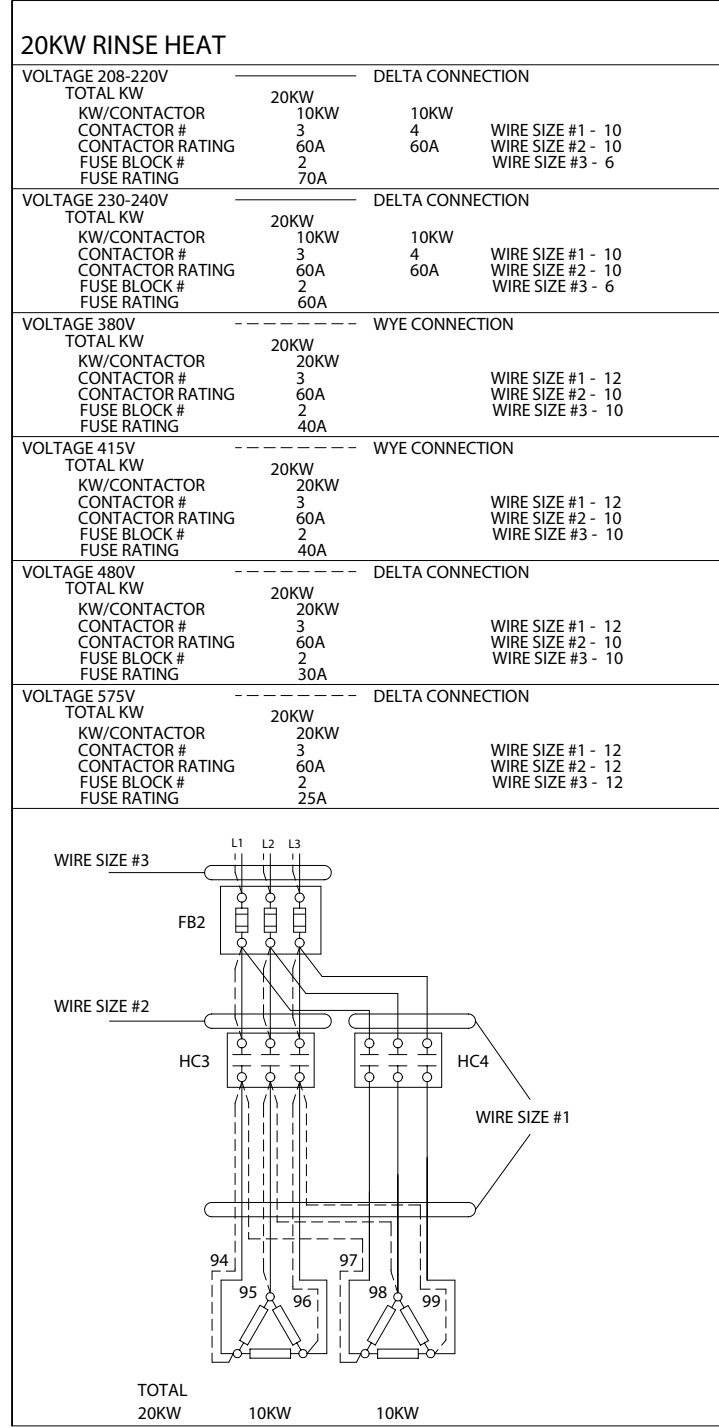

ON MODELS WITH TWO RINSE TANKS SECOND TANK HAS WIRE NUMBERS 94A THRU 99A

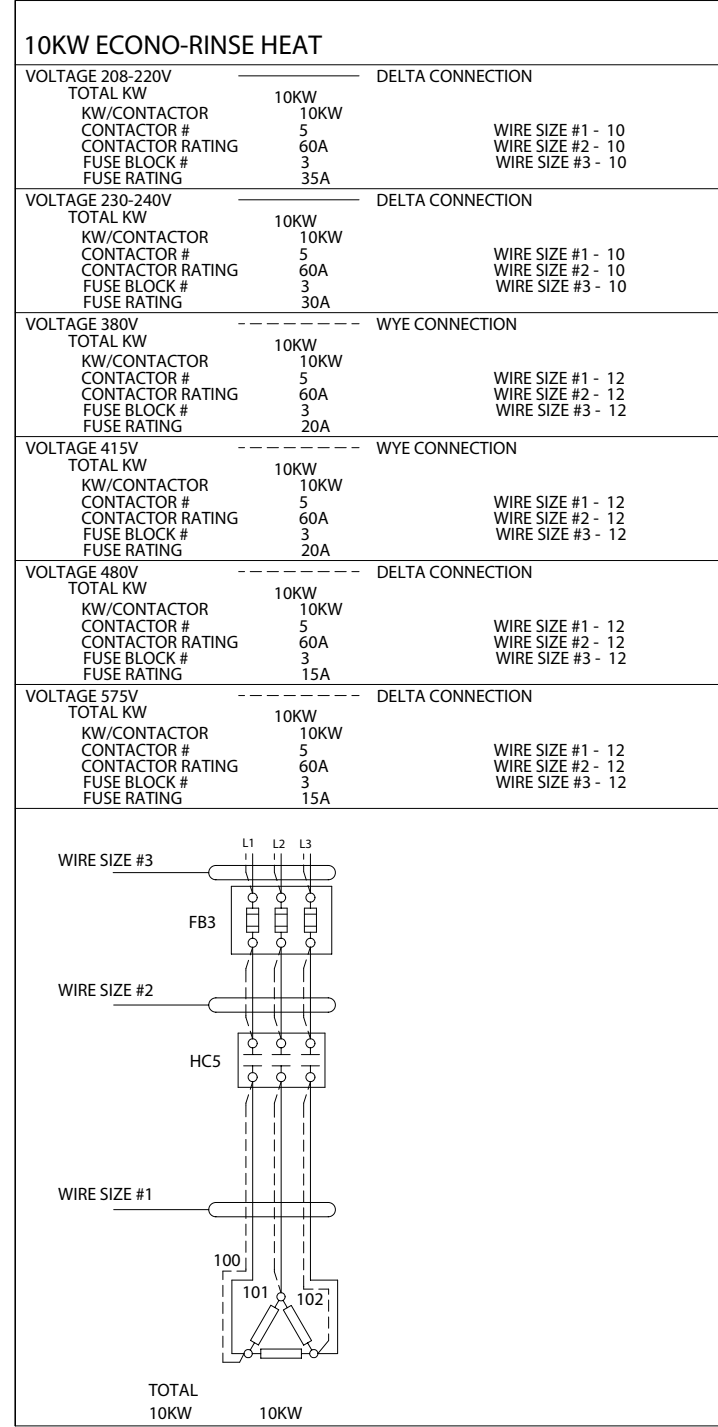

ER	ECONO RINSE	R	RINSE TANK
FB-	FUSE BLOCK	T	MACHINE TANK
HC-	HEAT CONTACTOR	W	WASH TANK

NOTES:  
1. ON MODELS WITH MULTIPLE ELECTRIC CONNECTIONS, MAKE HEATER POWER CONNECTIONS AT THE HEATER FUSE BLOCK.

CUSTOMER TO SUPPLY RATED VOLTAGE/PHASE/HZ, AS SPECIFIED PER ORDER, TO DISCONNECT SWITCH. ALL POWER SUPPLIED TO EACH CONNECTION POINT MUST COMPLY WITH ALL LOCAL ELECTRIC CODES.			
DR.BY	J.MCALLISTER	SCALE	NONE
DATE	11OCT05	SHEET	1 OF 1

REV.	DESCRIPTION	DATE	BY
A	ADDED WYE CONNECTION DETAILS	25AUG10	JAM
B	ADDED INFORMATION FOR MULTIPLE TANKS	12FEB14	JAM

REV.	DESCRIPTION	DATE	BY

 The Dishwashing Machine Specialists	EUCCW8 TANK HEAT WASH/RINSE/ECONO RINSE	
	B	701975
		REV. B