

Tall Hood-type Dishwashers

SERVICE REPLACEMENT PARTS

Pièces de Rechange - Partes de Reemplazo

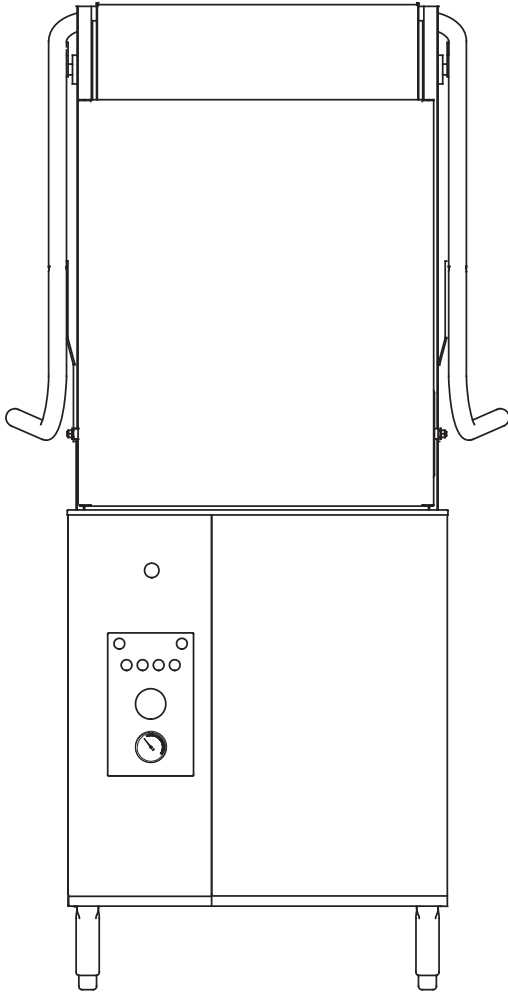

M1.5 Series

Models:
DH5000T, MDHHD

Options:
Ventless Heat Recovery



Issue Date: 4.25.17

Manual P/N 115745 rev. A

For machines beginning with S/N D150712811 and above

3765 Champion Boulevard
Winston-Salem, NC 27105
(336) 661-1556 Fax: (336) 661-1660
Toll-free: 1 (800) 858-4477

2674 N. Service Road, Jordan Station
Ontario, Canada L0R 1S0
(905) 562-4195 Fax: (90) 562-4618
Toll-free: 1 (800) 263-5798

Printed in the USA



National Service Department

In Canada:

Toll-free: 800/ 263-5798
Tel: 905/ 562-4195
Fax: 905/ 562-4618
email: service@moyerdiebellimited.com

In the USA:

Toll-free: 800/ 858-4477
Tel: 336/ 661-1556
Fax: 336/ 661-1660
email: service@championindustries.com

ATTENTION

The model no., serial no., voltage, Hz and phase are needed to identify your machine and to answer questions.

**The machine data plate
is located on the right front corner
of the lower panel**

Please have this information ready
if you call for service assistance.



Revision Record

REVISION DATE	PAGES	EFFECTIVE S/N	DESCRIPTION
2/1/16 4/25/17	ALL 27	D150712811 ALL	Released first edition Changed Item 1, to P/N 100742.

Limited Warranty

LIMITED WARRANTY

Champion Industries and Moyer Diebel (herein referred to as "The Companies"), 3765 Champion Blvd., Winston-Salem, North Carolina 27105, and 2674 N. Service Road, Jordan Station, Ontario, Canada, L0R 1S0, warrants machines, and parts, as set out below.

Warranty of Machines: The Companies warrant all new machines of its manufacture bearing the name "Champion or Moyer Diebel" and installed within the United States and Canada to be free from defects in material and workmanship for a period of one (1) year after the date of installation or fifteen (15) months after the date of shipment by The Companies, whichever occurs first. [See below for special provisions relating to glasswashers.] Warranty registration must be submitted to The Companies within ten (10) days after installation either online on the Champion Industries website (<http://www.championindustries.com>, or the Moyer Diebel website (<http://www.moyerdiebel.com> in the USA or <http://www.championindustries.com/canada> in Canada or by the fax form provided at the front of this manual. The Companies will not assume any responsibility for extra costs for installation in any area where there are jurisdictional problems with local trades or unions.

If a defect in workmanship or material is found to exist within the warranty period, The Companies, at their election, will either repair or replace the defective part or accept return of the machine for full credit; provided; however, as to glasswashers, The Companies' obligation with respect to labor associated with any repairs shall end (a) 120 days after shipment, or (b) 90 days after installation, whichever occurs first. In the event that The Companies elect to repair, the labor and work to be performed in connection with the warranty shall be done during regular working hours by a Champion or Moyer Diebel authorized service technician. Defective parts become the property of The Companies. Use of replacement parts not authorized by The Companies will relieve The Companies of all further liability in connection with its warranty. In no event will The Companies' warranty obligation exceed The Companies' charge for the machine. The following are not covered by The Companies' warranty:

- a. Lighting of gas pilots or burners.
- b. Cleaning of gas lines.
- c. Replacement of fuses or resetting of overload breakers.
- d. Adjustment of thermostats.
- e. Adjustment of clutches.
- f. Opening or closing of utility supply valves or switching of electrical supply current.
- g. Cleaning of valves, strainers, screens, nozzles, or spray pipes.
- h. Performance of regular maintenance and cleaning as outlined in the operator's guide.
- i. Damages resulting from water conditions, accidents, alterations, improper use, abuse, tampering, improper installation, or failure to follow maintenance and operation procedures.
- j. Wear on Pulper cutter blocks, pulse vanes, and auger brush.

Examples of the defects not covered by warranty include, but are not limited to: (1) Damage to the exterior or interior finish as a result of the above, (2) Use with utility service other than that designated on the rating plate, (3) Improper connection to utility service, (4) Inadequate or excessive water pressure, (5) Corrosion from chemicals dispensed in excess of recommended concentrations, (6) Failure of electrical components due to connection of chemical dispensing equipment installed by others, (7) Leaks or damage resulting from such leaks caused by the installer, including those at machine table connections or by connection of chemical dispensing equipment installed by others, (8) Failure to comply with local building codes, (9) Damage caused by labor dispute.

Warranty of Parts: The Companies warrant all new machine parts produced or authorized by The Companies to be free from defects in material and workmanship for a period of 90 days from date of invoice. If any defect in material and workmanship is found to exist within the warranty period The Companies will replace the defective part without charge.

DISCLAIMER OF WARRANTIES AND LIMITATIONS OF LIABILITY. THE COMPANIES' WARRANTY IS ONLY TO THE EXTENT REFLECTED ABOVE. THE COMPANIES' MAKE NO OTHER WARRANTIES, EXPRESS OR IMPLIED, INCLUDING, BUT NOT LIMITED, TO ANY WARRANTY OF MERCHANTABILITY, OR FITNESS OF PURPOSE. THE COMPANIES SHALL NOT BE LIABLE FOR INCIDENTAL OR CONSEQUENTIAL DAMAGES. THE REMEDIES SET OUT ABOVE ARE THE EXCLUSIVE REMEDIES FOR ANY DEFECTS FOUND TO EXIST IN THE COMPANIES' DISHWASHING MACHINES AND THE COMPANIES' PARTS, AND ALL OTHER REMEDIES ARE EXCLUDED, INCLUDING ANY LIABILITY FOR INCIDENTALS OR CONSEQUENTIAL DAMAGES.

The Companies do not authorize any other person, including persons who deal in Champion or Moyer Diebel dishwashing machines to change this warranty or create any other obligation in connection with Champion or Moyer Diebel dishwashing machines.

Service Replacement Parts

Illustrations	Page
Operator Control Panel.....	2
Control Cabinet	4
Track and Panels.....	6
Wash Pump/Motor Assembly	8
Fill Piping with and without Booster - Standard.....	10
Fill Piping with Booster - VHR.....	12
Electric Booster	14
Wash/Rinse Spray Piping - Standard.....	16
Wash/Rinse Spray Piping - VHR	18
Wash and Rinse Spray Arms	20
Venting - VHR	22
Wash Tank Heat, Pump Hoses, Drain Valve, and Screens.....	24
Hood and Handle	26
Back Support and Guides	28
Drain Water Tempering.....	30
Hot Water Coil Heat.....	32
Dish racks, Line Strainer and Pressure Regulating Valve (PRV)	34

Operator Control Panel

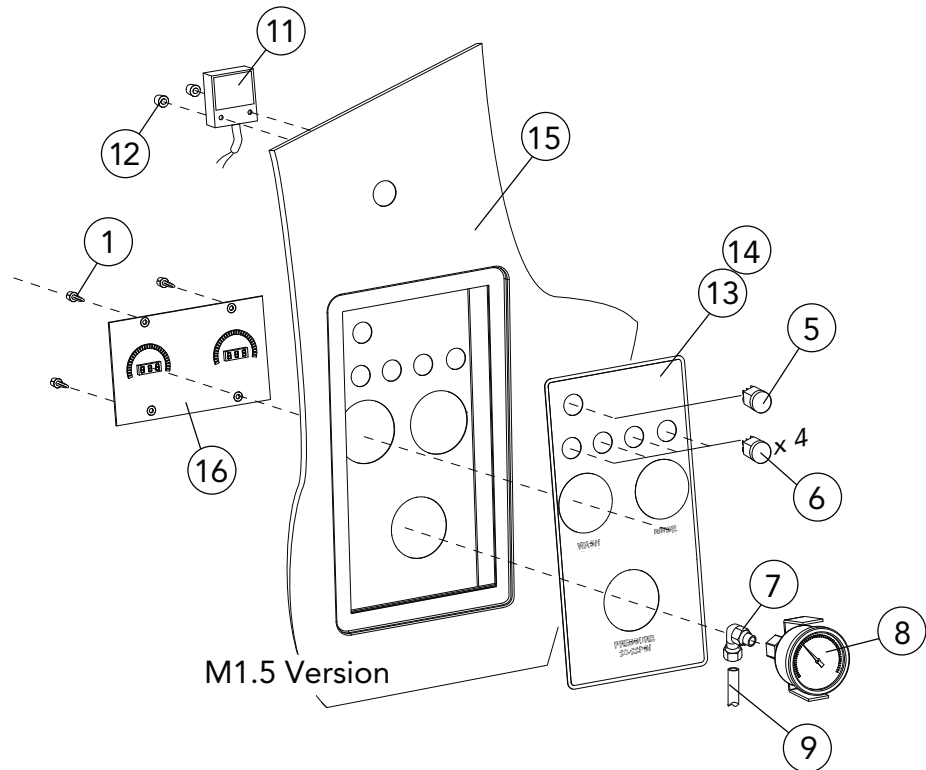
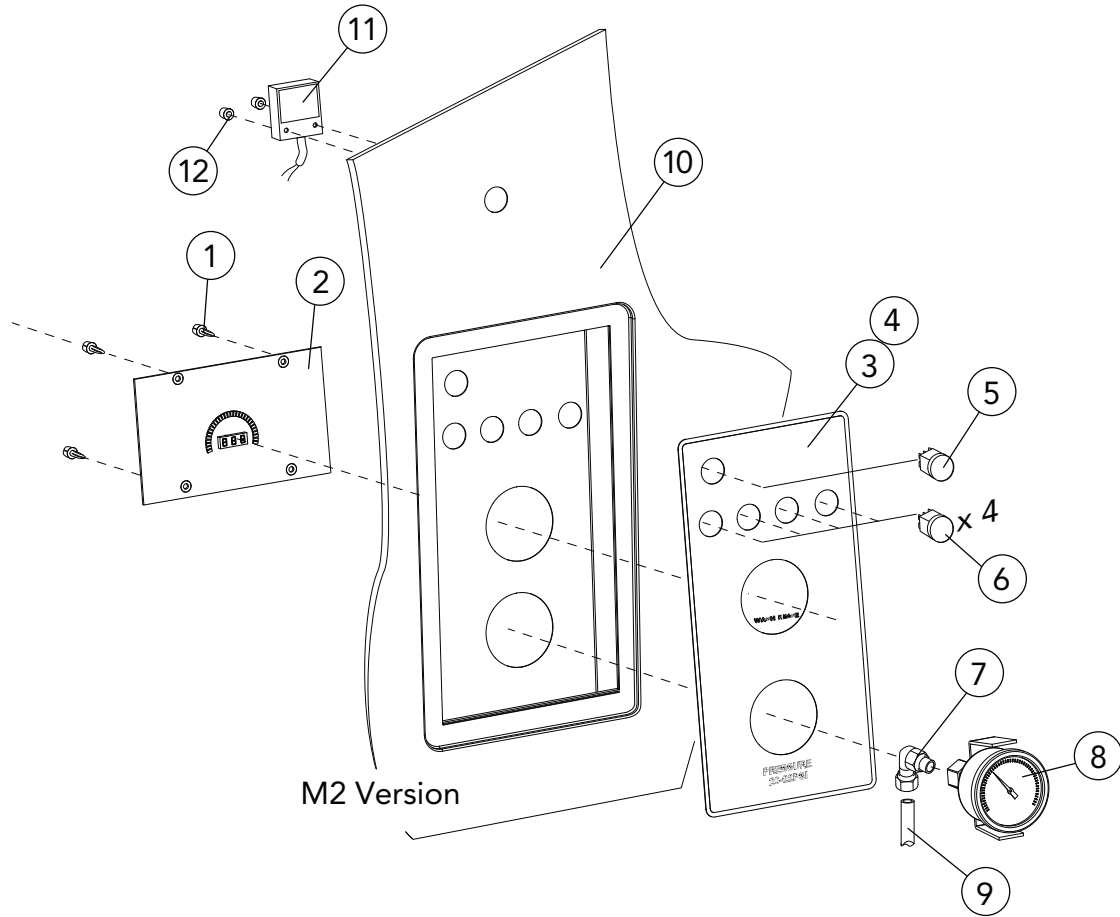

Item No.	Part No.	Description	Qty.
1	114559	SUPPORT, PRINTED CIRCUIT BOARD	4
2	116206	SINGLE, DIGITAL TEMPERATURE DISPLAY (M2 Version Only)	1
3	116327	DECAL, FRONT PANEL, DH5000T (Champion Only)	1
4	116327-M	DECAL, FRONT PANEL, MDHHD (Moyer Diebel Only)	1
5	115616	SWITCH, PUSH BUTTON, POWER - GREEN	1
6	115617	SWITCH, PUSH BUTTON, CYCLE - BLUE	4
7	111100	ELBOW, 1/4" OD X 1/8" NPT FEMALE, PLASTIC	1
8	109812	GAUGE, PRESSURE, 0-60 PSI	1
9	107414	TUBING, 1/4" NATURAL P44	10 FT
10*	-----	CONTROL PANEL, HINGED LH (M2 Only)	1
11	115628	CYCLE LIGHT, LED	1
12	108954	NUT, GRIP 6-32 W/NYLON INSERT SST	2
13	115614	DECAL, FRONT PANEL, MDHH-D (Moyer Diebel Only)	1
14	115560	DECAL, FRONT PANEL, DH5000T (Champion Only)	1
15	420044-S	CONTROL PANEL, HINGED LH (M1.5 Only)	1
16	114489	DUAL, DIGITAL TEMPERATURE DISPLAY (M 1.5 Version Only)	1
—	114508	CABLE ASSY., 4-CONDUCTOR (Not shown) THERMISTOR TO DISPLAY CONNECT	1

* CONSULT FACTORY FOR THIS PART NUMBER

Control Cabinet

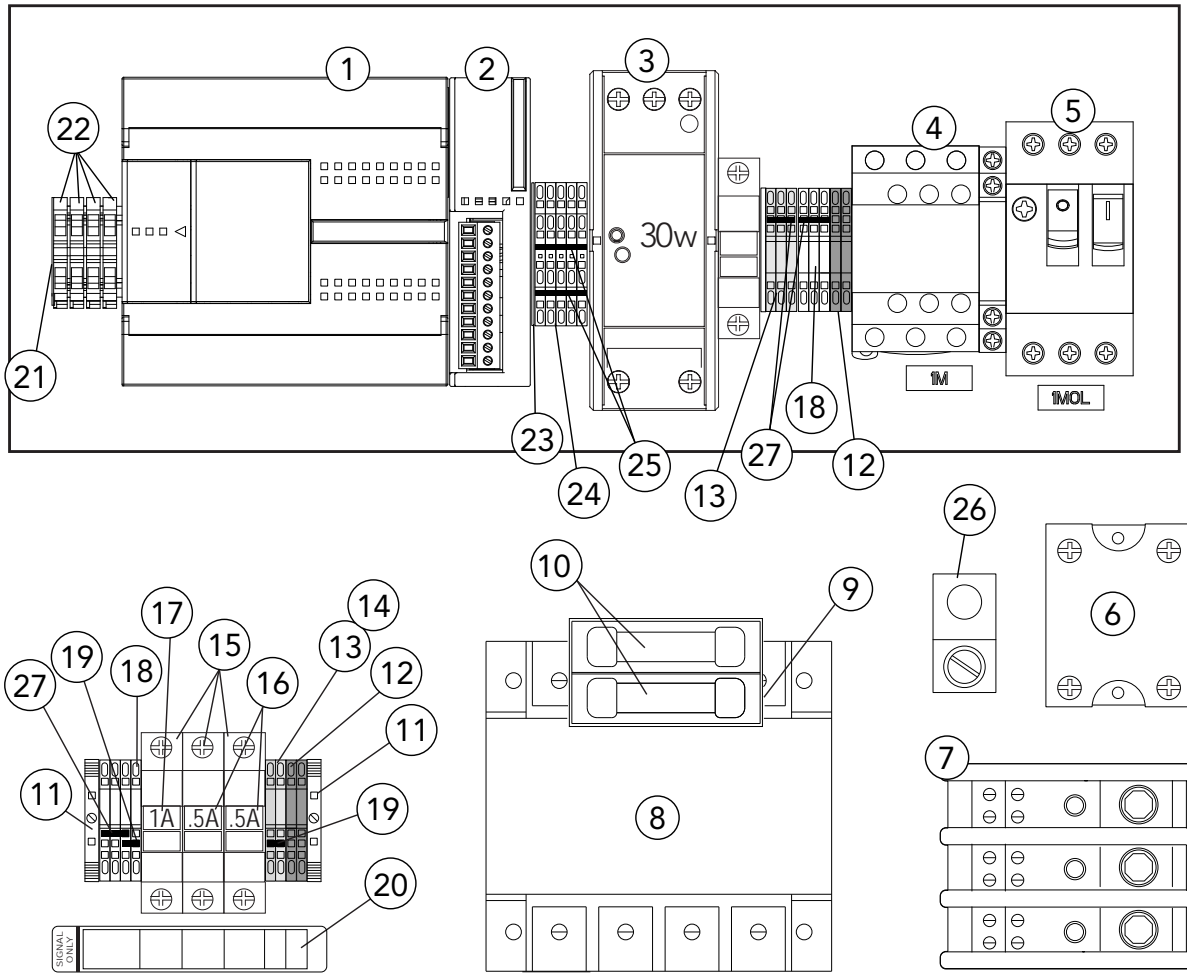

Item No.	Part No.	Description	Qty.
1	115603	PLC - (PROGRAMMABLE LOGIC CONTROLLER)	1
2	115605	RELAY, OUTPUT, 8-POINT	1
3	115607	POWER SUPPLY, 24V, 30W	1
4	108122	CONTACTOR, 12A, 3-POLE	1
5	113161	STARTER, MTR. OVERLOAD, 208-230V/60/1, 9.0-14.0A	1
—	111629	STARTER, MTR. OVERLOAD, 208-230V/60/3, 6.0-10.0A	1
—	111628	STARTER, MTR. OVERLOAD, 440-480V/60/3, 4.0-6.3A	1
6	115648	RELAY, SOLID STATE (MOUNTED ON WASH TANK)	A/R
7	111833	BLOCK, INPUT TERMINAL. 175A, 3-POLE, 600V	1
8	109064	XFRMR, INPUT 250VA, MV:120V	1
9	112424	BLOCK, FUSE KIT	1
10	112482	FUSE, 3.5A, 600V, TIME DELAY 208-240V/60/1 & 3	2
—	112484	FUSE, 1.5A, 600V, TIME DELAY 460-480V/60/3	2
11	114519	BLOCK, END, E/NS 35 N	2
12	114515	TERMINAL, SINGLE GROUND, ST 2.5 PE	4
13	114512	TERMINAL, SINGLE, ST 2.5 GRAY	
14	114516	END COVER, SINGLE TERMINAL D-ST 2.5	1
15	111153	BLOCK, FUSE	3
16	116213	FUSE, 0.5A	2
17	112901	FUSE, 1.0A	1
18	114514	TERMINAL, SINGLE ST 2.5 WHITE	7
19	114523	BRIDGE, 2-POLE	2
20	116149	LABEL, SIGNAL DETERGENT/RINSE-AID/VENT FAN/LINE	1
21	114521	END COVER, SINGLE TERMINAL, D-MZB 1.5-NS35	1
22	114520	TERMINAL, SINGLE, MZB 1.5-NS35	4
23	114518	END COVER, DOUBLE TERMINAL, D-STTB 2.5	1
24	114517	TERMINAL, DOUBLE, STTB 2.5	5
25	114522	BRIDGE, 10-POLE	2
26	103310	GROUND LUG	1
27	114524	BRIDGE, 3-POLE	3
—	114508	CABLE ASSY., 4-CONDUCTOR <i>(Not Shown)</i> THERMISTOR TO DISPLAY BD.	1

Track and Panels

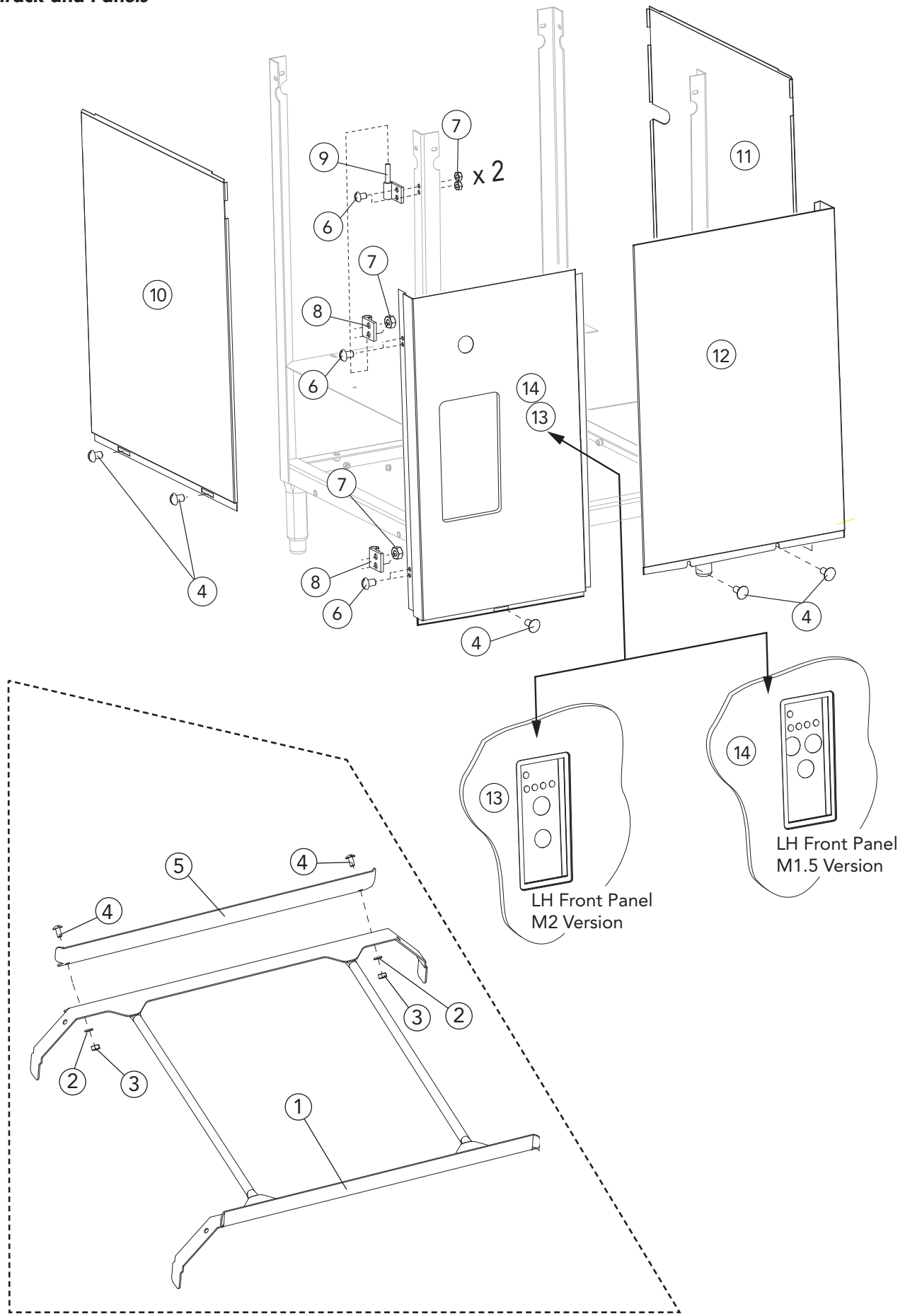

Item No.	Part No.	Description	Qty.
1	335780	TRACK ASSEMBLY	1
2	106482	WASHER, LOCK 1/4 SPLIT, SST	2
3	100003	NUT, HEX PLAIN 1/4-20 SST	2
4	100073	SCREW, TRUSS HEAD, 1/4-20 X 1/2" SST	9
5	332023	TRACK, RAIL ADJUST	1
6	107966	NUT GRIP, 10-32 W/NYLON INSERT	8
7	100097	SCREW, 10-32 X 1/2" TRUSS HD. SST	8
8	115454	HINGE, FLAG FEMALE	2
9	115428	HINGE, FLAG/PIN	2
10	337072	PANEL, LH SIDE, M2 (STD. & DV)	1
---	337073	PANEL, LH SIDE, M2 (VHR)	1
11	337070	PANEL, RH SIDE M2 (ALL)	1
12	337071	PANEL, FRONT RH (ALL)	1
13*	420044-S	CONTROL PANEL, HINGED LH (M1.5 ONLY)	1
14*	SEE NOTE	CONTROL PANEL, HINGED LH (M2 ONLY)	1

* SEE PAGES 2-3 FOR THE OPERATOR CONTROL PANEL PARTS.

NOTE: CONSULT FACTORY FOR THIS PART NUMBER

Wash Pump/Motor Assembly

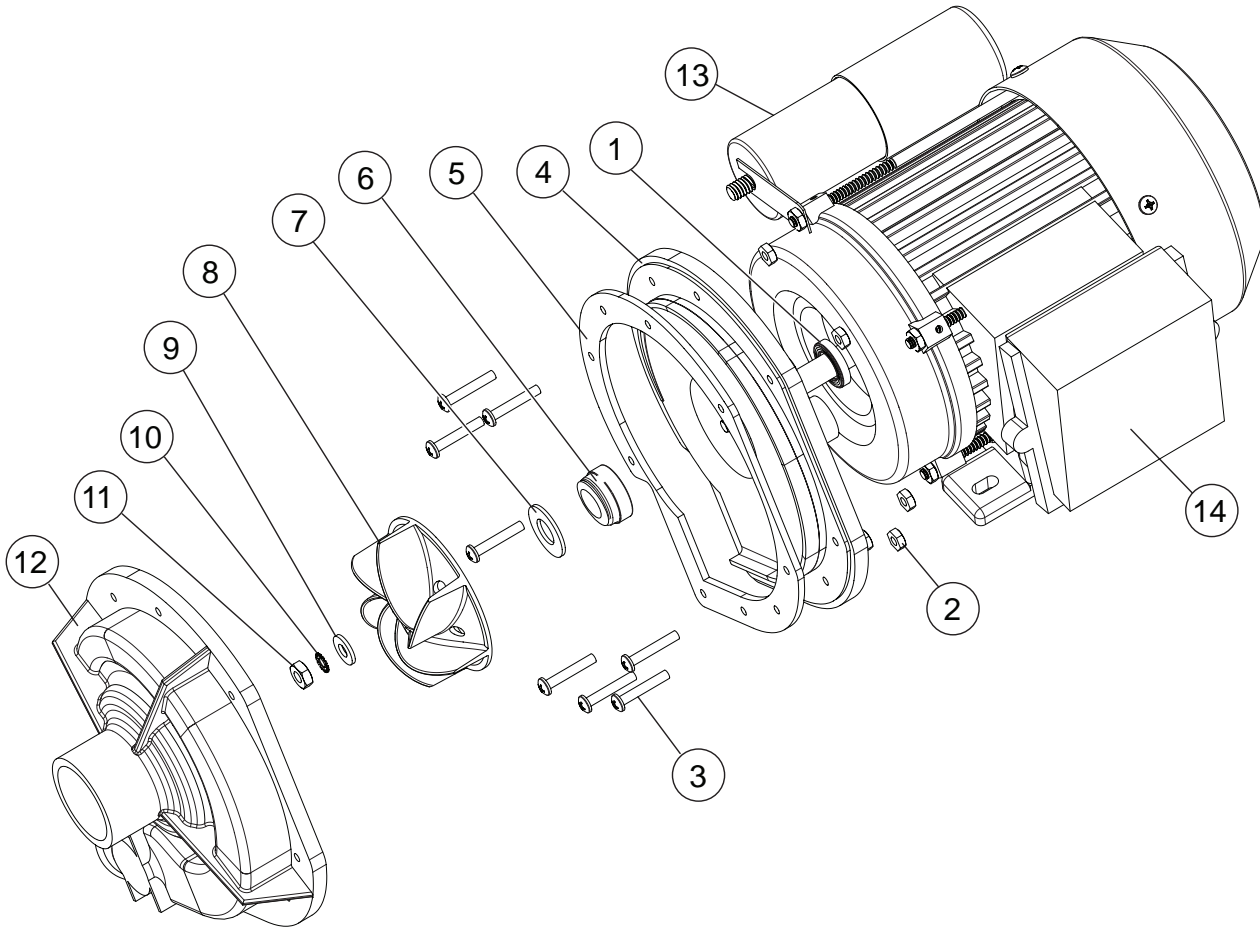

Item No.	Part No.	Description	Qty.
1	114134	SLINGER, WATER	1
2	107337	NUT, PLAIN M4	9
3	0512340	SCREW, VOLUTE	9
4	114137	PLATE, BACKING, C/W CAPACITOR BRKT.	1
5	110285	GASKET, PUMP	1
6	114139	SEAL, PUMP	1
7	114140	WASHER	1
8	114141	IMPELLER	1
9	114142	WASHER	1
10	114143	WASHER, LOCK	1
11	114144	NUT, IMPELLER (LH THREADS)	1
12	114145	HOUSING, PUMP	1
13	112637	CAPACITOR 31.5 μ F	1
14	115143	PUMP/MOTOR ASSEMBLY COMPLETE 208-240VAC/50-60/1PH, 2HP	1
-	115144	PUMP/MOTOR ASSEMBLY COMPLETE 208-266/360-460VAC/60/3PH, 2HP	1
-	115429	PUMP/MOTOR ASSEMBLY COMPLETE 230VVAC/50/1PH, 2HP <i>(For 380-415V/50/3 machines)</i>	1

THE MOTOR CANNOT BE ORDERED SEPARATELY.

Fill Piping with and without Booster - Standard

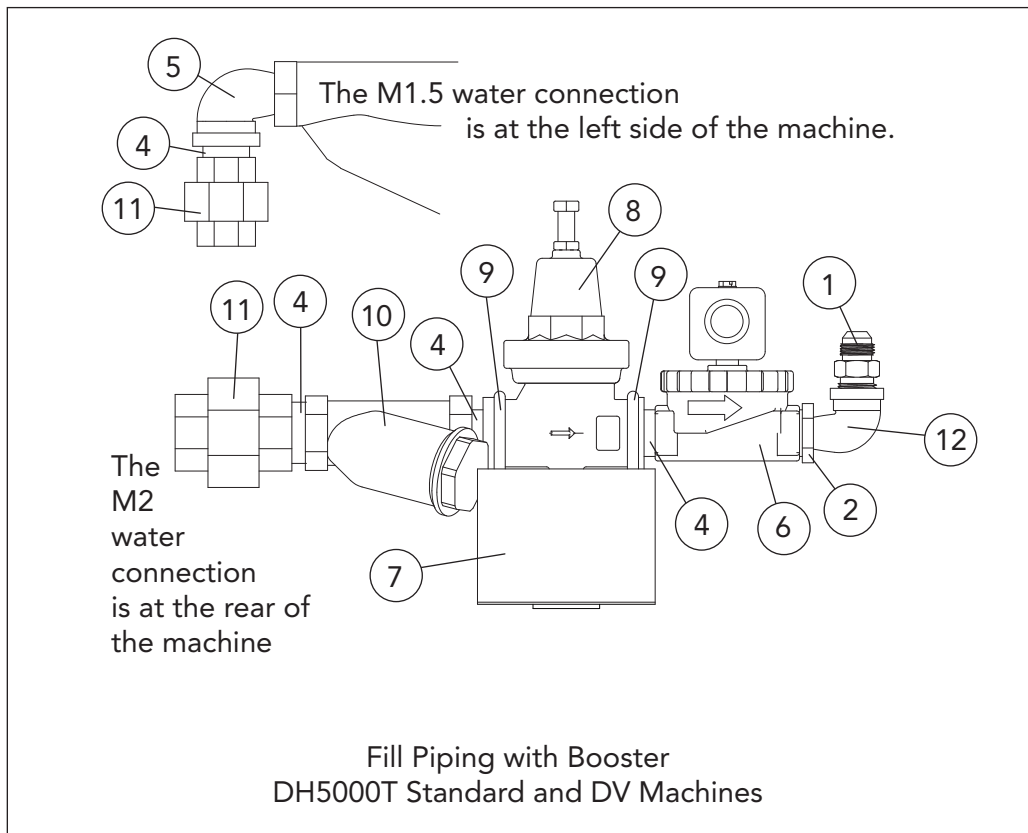
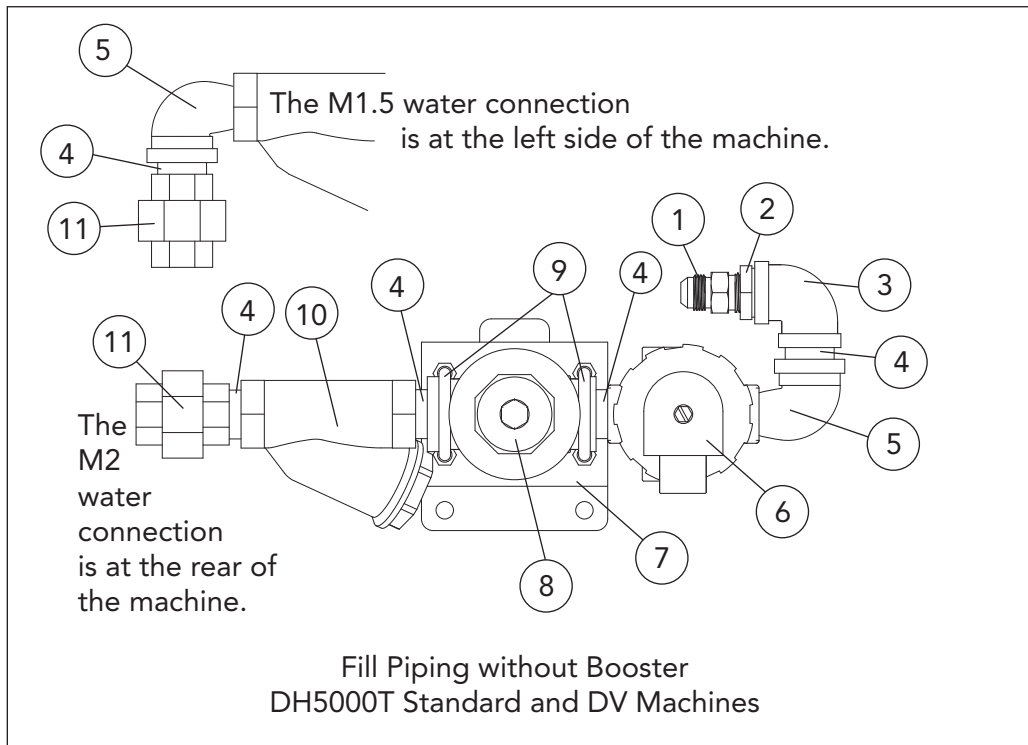

Fill Piping with and without Booster - Standard

Item No.	Part No.	Description	Qty.
1	115101	CONNECTOR, MALE 1/2" NPT X 1/2" 37° FLARE BRASS	1
2	102392	BUSHING, REDUCING, 3/4" NPT X 1/2" NPT BRASS	A/R
3	102442	ELBOW, 3/4" NPT X 90° BRASS	1s
4	100184	NIPPLE, 3/4" NPT X CLOSE BRASS	A/R
5	102444	ELBOW, STREET 3/4" NPT X 90° BRASS	A/R
6	111437	VALVE, SOLENOID 3/4" NPT HW	1
-	114839	KIT, REPAIR VALVE 3/4" HW	A/R
-	111472	COIL, SOLENOID 3/4" 120V	A/R
7	334775	BRACKET, DH5000 INLET PLUMBING SUPPORT	1
8	107550	VALVE, PRESSURE REGULATING 3/4" NPT BRONZE	1
9	115169	U-BOLT, 1/4-20 X 1 3/4" X 3" LG. (COMES WITH NUTS)	2
10	110768	STRAINER, LINE 3/4" NPT BRONZE FEMALE	1
11	100571	UNION, 3/4" NPT BRASS	1
12	102438	ELBOW, STREET 1/2" NPT X 90° BRASS (with booster only)	1

Fill Piping with Booster - VHR

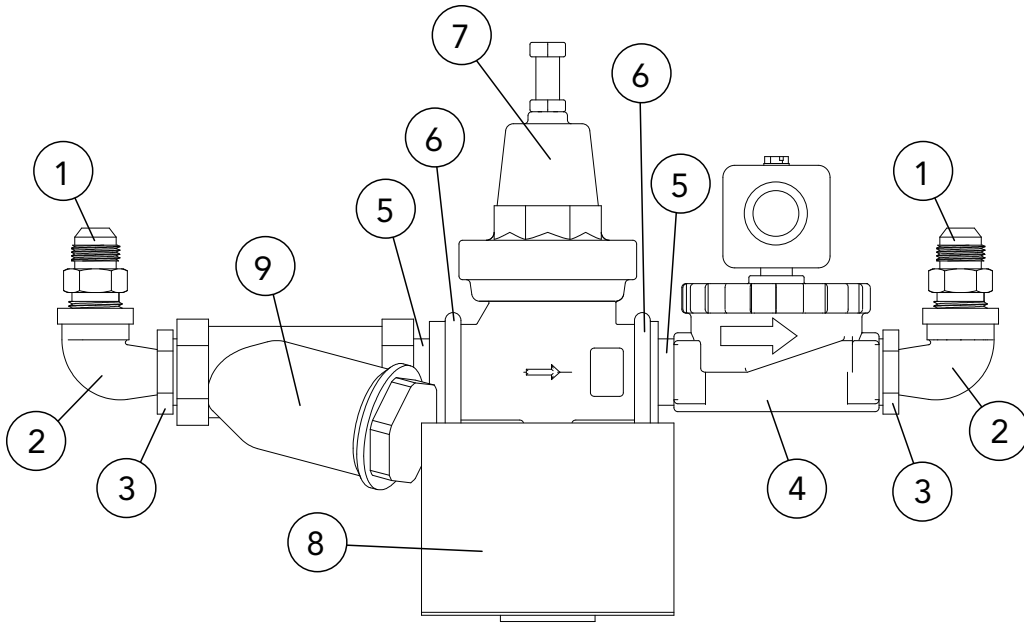

Item No.	Part No.	Description	Qty.
1	115101	CONNECTOR, MALE 1/2" NPT X 1/2" 37° FLARE BRASS	1
2	102438	ELBOW, STREET 1/2" NPT X 90° BRASS	2
3	102392	BUSHING, REDUCING, 3/4" NPT X 1/2" NPT BRASS	2
4	111437	VALVE, SOLENOID 3/4" NPT HW	1
-	114839	KIT, REPAIR VALVE 3/4" HW	A/R
-	111472	COIL, SOLENOID 3/4" 120V	A/R
5	100184	NIPPLE, 3/4" NPT X CLOSE BRASS	2
6	115169	U-BOLT, 1/4-20 X 1 3/4" X 3" LG. (COMES WITH NUTS)	2
7	107550	VALVE, PRESSURE REGULATING 3/4" NPT BRONZE	1
8	334775	BRACKET, DH5000 INLET PLUMBING SUPPORT	1
9	110768	STRAINER, LINE 3/4" NPT BRONZE FEMALE	1

Electric Booster

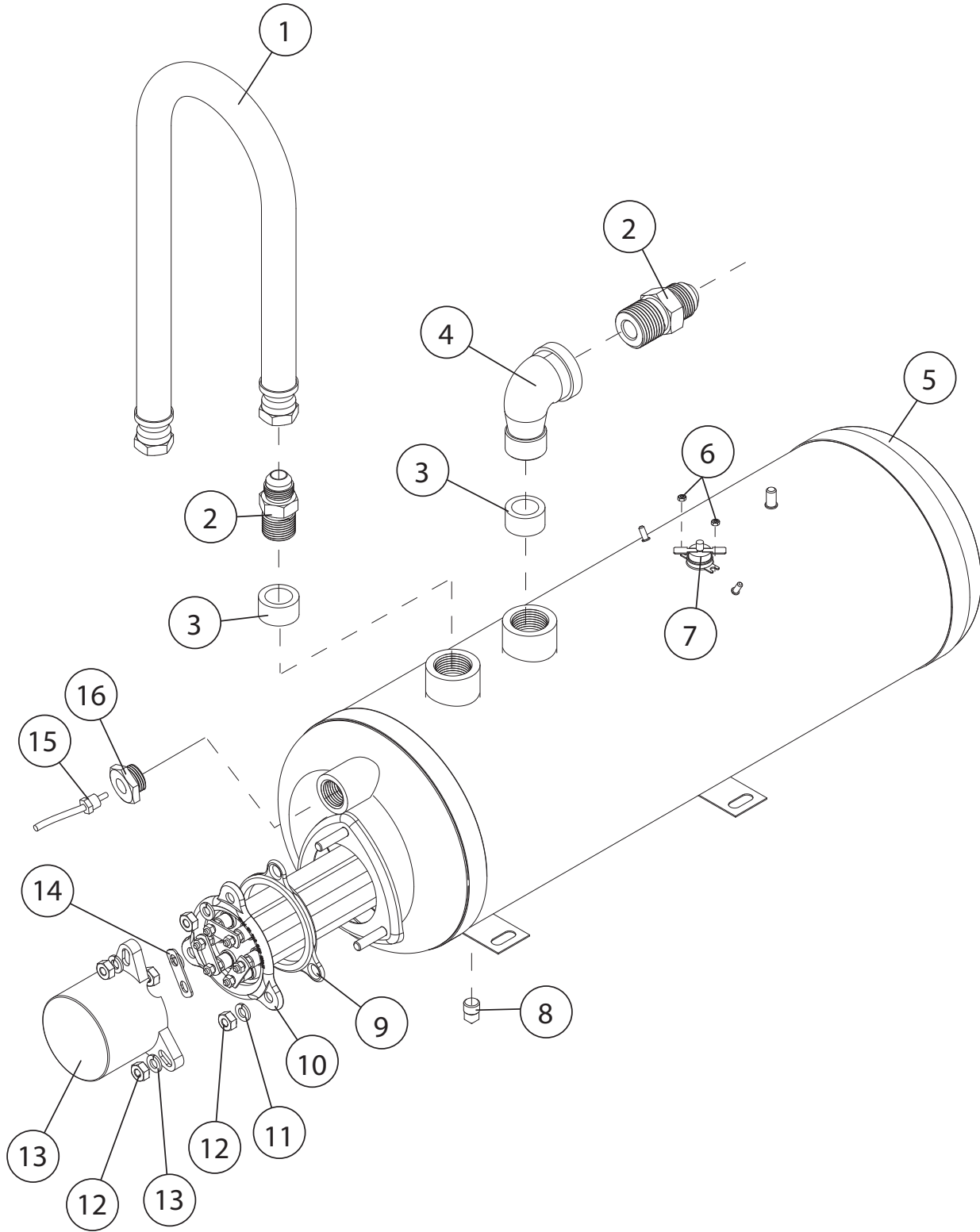

Item No.	Part No.	Description	Qty.
1	419002	HOSE ASSY. 1/2" ID, X 16" LG. FLARE JIC	1
2	115101	CONNECTOR, MALE 1/2" NPT X 1/2" 37° FLARE BRASS	2
3	100171	BUSHING, REDUCING FACE 3/4" NPT X 1/2" NPT BRASS	2
4	102438	ELBOW, STREET 1/2" NPT X 90° BRASS	1
5	0509042	BOOSTER TANK, WELDED ASSEMBLY	1
6	108954	NUT, GRIP, 6-32 W/NYLON INSERT SST	2
7	110562	THERMOSTAT, FIXED, SNAP, 240°F	1
8	100210	PLUG, 1/8" NPT SQ. HEAD, SST	1
9	109985	SEAL, ELECTRIC HEATER FLANGE	1
<u>For Standard Model and Direct Vent Option Model</u>			
10	111233	HEATER, 7.5KW/10KW, 208-240V/60/1PH & 3PH	1
—	108579	HEATER, 9KW, 480V/60/3PH	1
<u>For VHR Option Model Only</u>			
10	111232	HEATER, 10KW, 208-240V/60/1PH & 3PH	1
—	111234	HEATER, 10KW, 480V/60/3PH	1
11	106482	WASHER, LOCK 1/4" SPLIT SST	6
12	100003	NUT, PLAIN, 1/4-20 SST	6
13	107908	COVER, HEATER	1
14	111488	JUMPER, STRIP HEATER	1
15	114435	THERMISTOR, 10kΩ, 36" LEAD (M2 ONLY)	1
16	115530	ADAPTER	1

Wash/Rinse Spray Piping - Standard

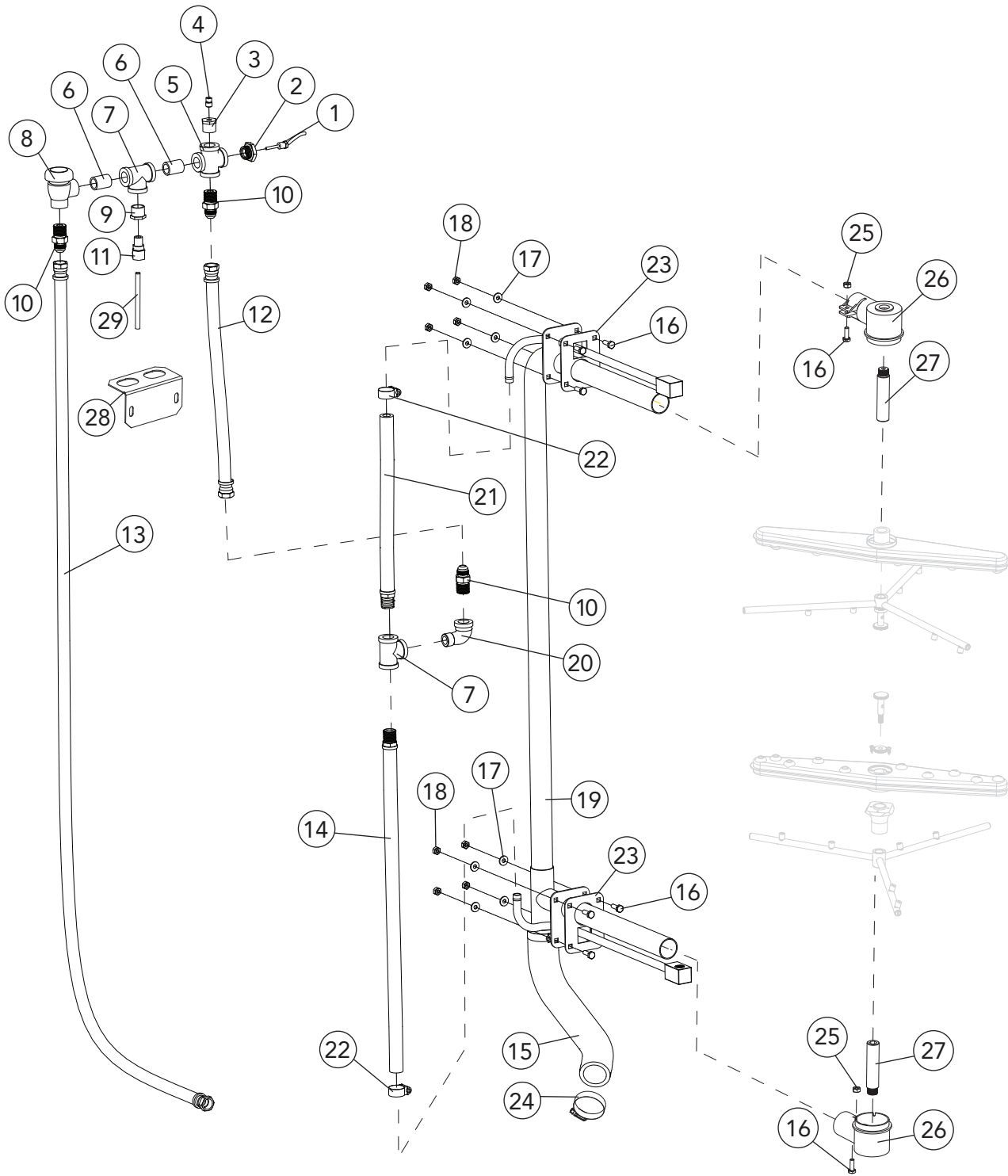

Wash and rinse spray arms are on pages 20-21.

Item No.	Part No.	Description	Qty.
1	114435	THERMISTER, 10K Ω , 36" LEAD	1
2	115530	ADAPTER, THERMISTOR	1
3	103418	BUSHING, REDUCING 1/2" NPT X 1/8" NPT BRASS	1
4	101259	PLUG, 1/8" NPT SQ. HEAD, BRASS	1
5	100598	CROSS, 1/2" NPT, BRASS	1
6	100209	NIPPLE, 1/2" NPT X CLOSE BRASS	2
7	102514	TEE, 1/2" NPT BRASS	2
8	100500	BREAKER, VACUUM 1/2" NPT BRONZE	1
-	900836	KIT, REPAIR VACUUM BREAKER 1/2"	A/R
9	102388	BUSHING, REDUCING 1/2" NPT X 1/4" NPT BRASS	1
10	115101	CONNECTOR, MALE 1/2" NPT X 1/2" 37° FLARE BRASS	3
11	107065	ADAPTER, 1/4" OD X 1/4" MPT PLASTIC	1
12	419974	HOSE ASSY, 1/2" ID X 14" LG. FLARE JIC	1
13	419973	HOSE ASSY., 1/2" ID X 64" LG. FLARE JIC	1
14	419008	HOSE ASSY., 1/2" ID X 22" LG. FLARE JIC	1
15	114863	HOSE, DISCHARGE	1
16	100736	BOLT, HEX HD., 1/4-20 X 3/4" SST	10
17	106026	WASHER, FLAT 1/4" SST	8
18	100003	HEX PLAIN NUT 1/4-20 SST	8
19	336143	STANDPIPE, WASH/RINSE	1
20	102438	ELBOW, STREET 1/2" NPT X 90°, BRASS	1
21	419001	HOSE ASSY., 1/2" ID X 12" LG. FLARE JIC	1
22	105994	CLAMP, HOSE M10 SST GEAR-TYPE	2
23	114902	GASKET, STANDPIPE	2
24	107340	CLAMP, HOUSE M28 SST GEAR-TYPE	2
25	107967	NUT, GRIP 1/4-20 W/NYLON INSERT	2
26	109864	HUB SUPPORT, WASHARM	2
27	0507445	SPINDLE, WASHARM	2
28	336893	BRACKET, VACUUM BREAKER PIPING	1
29	107414	TUBING, 1/4" NATURAL P44	10 FT

Wash/Rinse Spray Piping - VHR

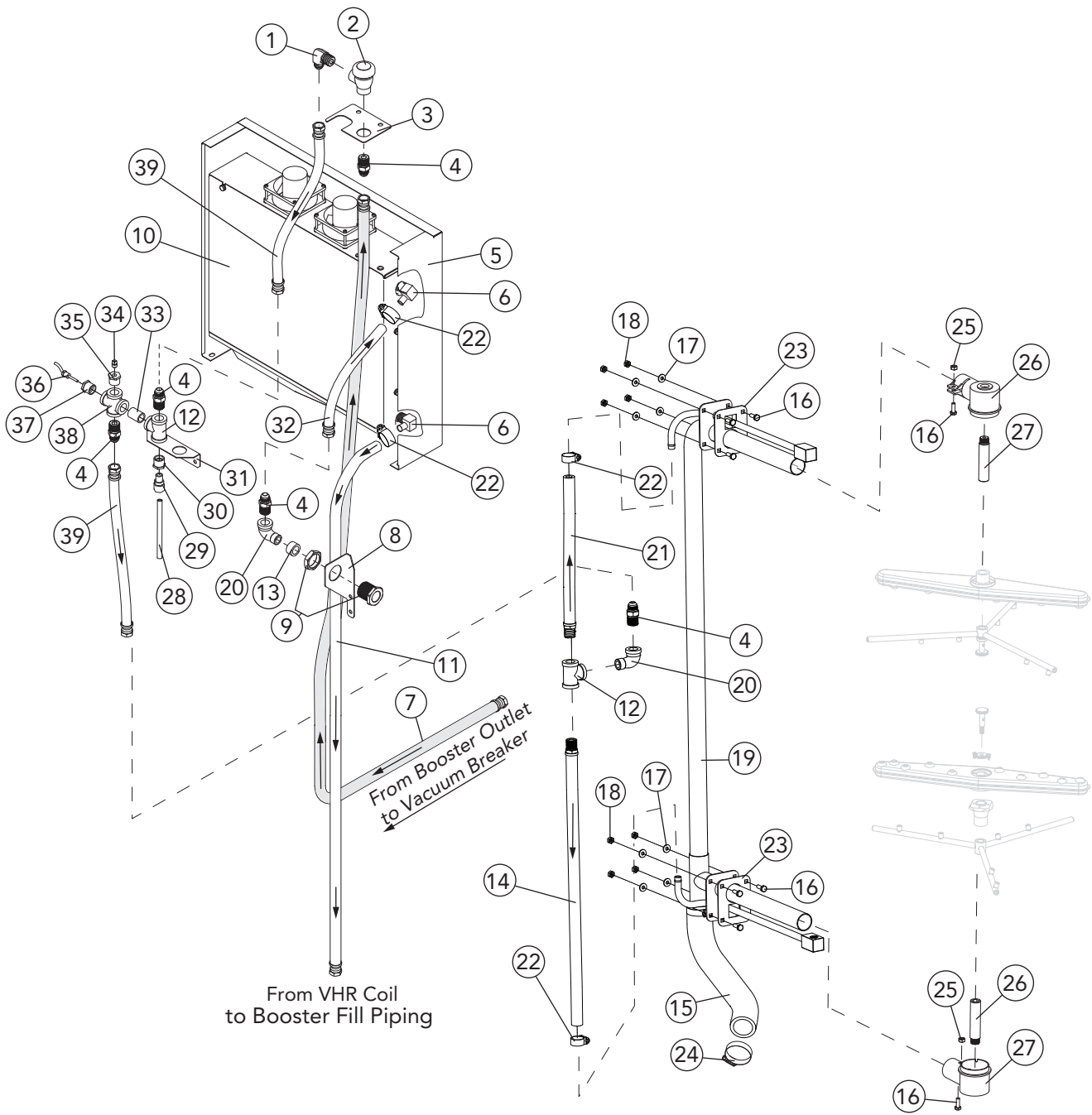

Wash and rinse spray arms are on pages 20-21.

Item No.	Part No.	Description	Qty.
1	115101	ELBOW, MALE 1/2" NPT X 1/2" 37° FLARE JIC	1
2	100500	BREAKER, VACUUM 1/2" NPT BRONZE	1
-	900836	KIT, REPAIR VACUUM BREAKER 1/2"	A/R
3	334681	BRACKET, PIPING SUPPORT VACUUM BREAKER	1
4	115101	CONNECTOR, MALE 1/2" NPT X 1/2" 37° FLARE BRASS	5
5	336480	COIL, VHR SHROUD	1
6	108528	BARB, HOSE EL, 1/2" NPT X 1/2 H, BRASS	2
7	419013	HOSE ASSY., 1/2" ID, BSTR TO VBREAKER 80" LG.	1
10	419763	COIL, VHR	1
11	420122	HOSE ASSY., 1/2" ID, VHR COIL TO FILL PIPING, 65" LG.	1
12	102514	TEE, 1/2" NPT BRASS	2
13	100171	BUSHING, RED. FACE, 3/4" X 1/2" BRASS	1
14	419008	HOSE ASSY., 1/2" ID X 22" LG. FLARE JIC	1
15	114863	HOSE, DISCHARGE	1
16	100736	BOLT, HEX HD., 1/4-20 X 3/4" SST	10
17	106026	WASHER, FLAT 1/4" SST	8
18	100003	NUT, HEX PLAIN 1/4-20 SST	8
19	336143	STANDPIPE, WASH/RINSE	1
20	102438	ELBOW, STREET 1/2" NPT X 90°, BRASS	1
21	419001	HOSE ASSY., 1/2" ID X 12" LG. FLARE JIC	1
22	105994	CLAMP, HOSE GEAR-TYPE SST	2
23	114902	GASKET, STANDPIPE	2
24	107340	CLAMP, HOUSE M28 SST GEAR-TYPE	2
25	107967	NUT, GRIP 1/4-20 W/NYLON INSERT	2
26	109864	HUB SUPPORT, WASHARM	2
27	0507445	SPINDLE, WASHARM	2
28	107414	TUBING, 1/4" HIGH DENSITY	10 FT
29	107065	ADAPTER, 1/4" OD X 1/4" MPT PLASTIC	1
30	102388	BUSHING, REDUCING 1/2" NPT X 1/4" NPT BRASS	1
31	336893	BRACKET, PLUMBING SUPPORT	1
32	420123	HOSE ASSY., 1/2" ID X 11" LG. FLARE JIC (HOSE CLAMP COIL END)	1
33	100209	NIPPLE, 1/2" NPT X CLOSE BRASS	1
34	101259	PLUG, 1/8" NPT SQ. HEAD, BRASS	1
35	103418	BUSHING, REDUCING 1/2" NPT X 1/8" NPT BRASS	1
36	114435	THERMISTER, 10KΩ, 36" LEAD	1
37	115530	ADAPTER, THERMISTOR	1
38	100598	CROSS, 1/2" NPT, BRASS	1
39	419974	HOSE ASSY., 1/2" ID X 14" LG. FLARE JIC	2

Wash and Rinse Spray Arms

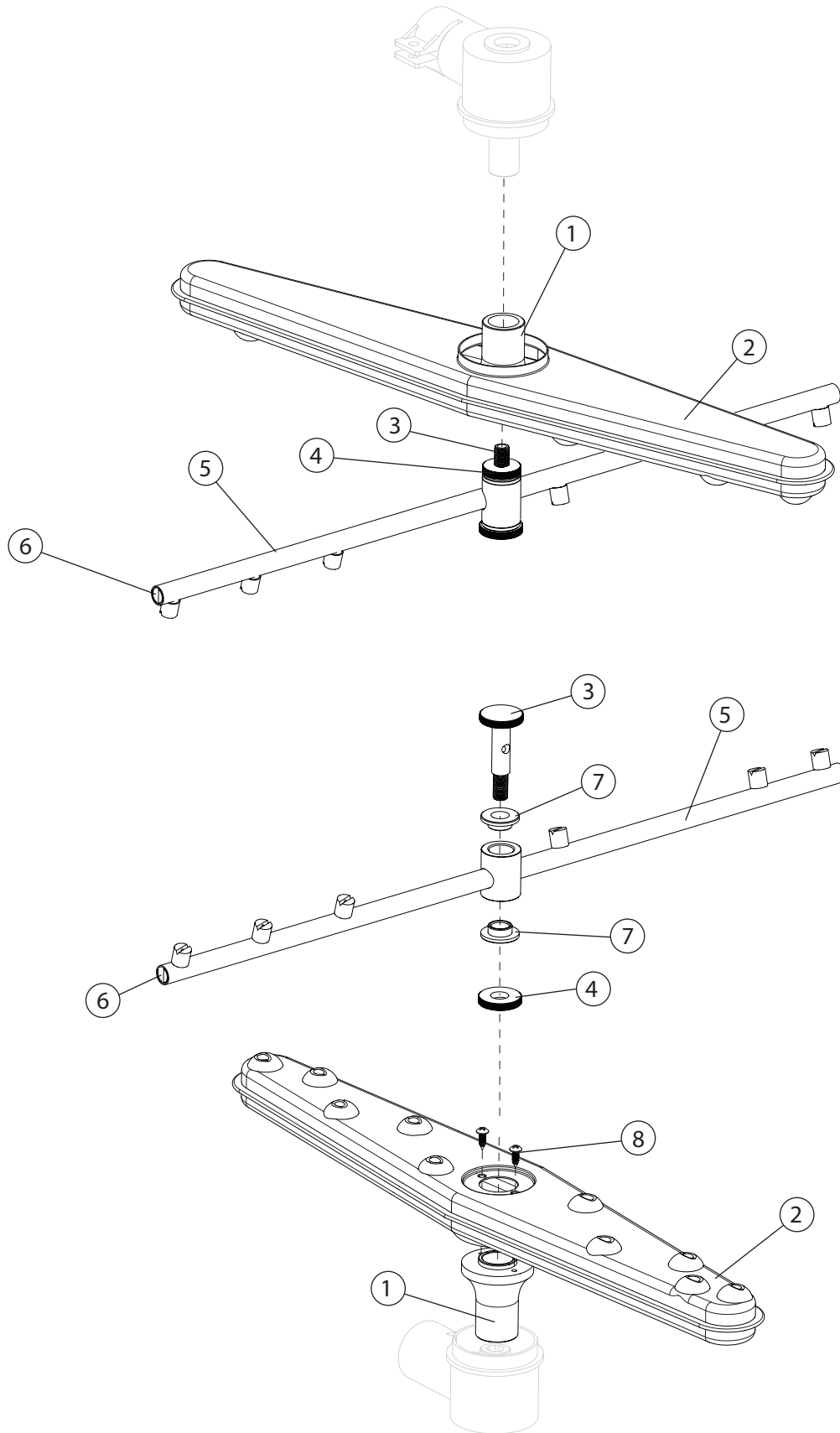

Item No.	Part No.	Description	Qty.
1	207096	WASHARM, BEARING	2
2	114858	WASHARM, WELDMENT	2
3	0507443	SPINDLE, RINSE ARM	2
4	114556	NUT, SPINDLE	2
5	115222	RINSE ARM, WELDMENT	2
6	114861	ENDCAP, HEADLESS, 7/16-20 SST	6
7	113514	BEARING, RINSE ARM	4
8	109835	SCREW, #8 X 1/2" SELF-TAPPING PAN HEAD, PHILLIPS	4
—	900975	RINSE ARM ASSEMBLY, COMPLETE (INCLUDES ITEMS 5-7)	2
—	900954	WASH ARM ASSEMBLY, COMPLETE (INCLUDES ITEMS 1,2 & 8)	2

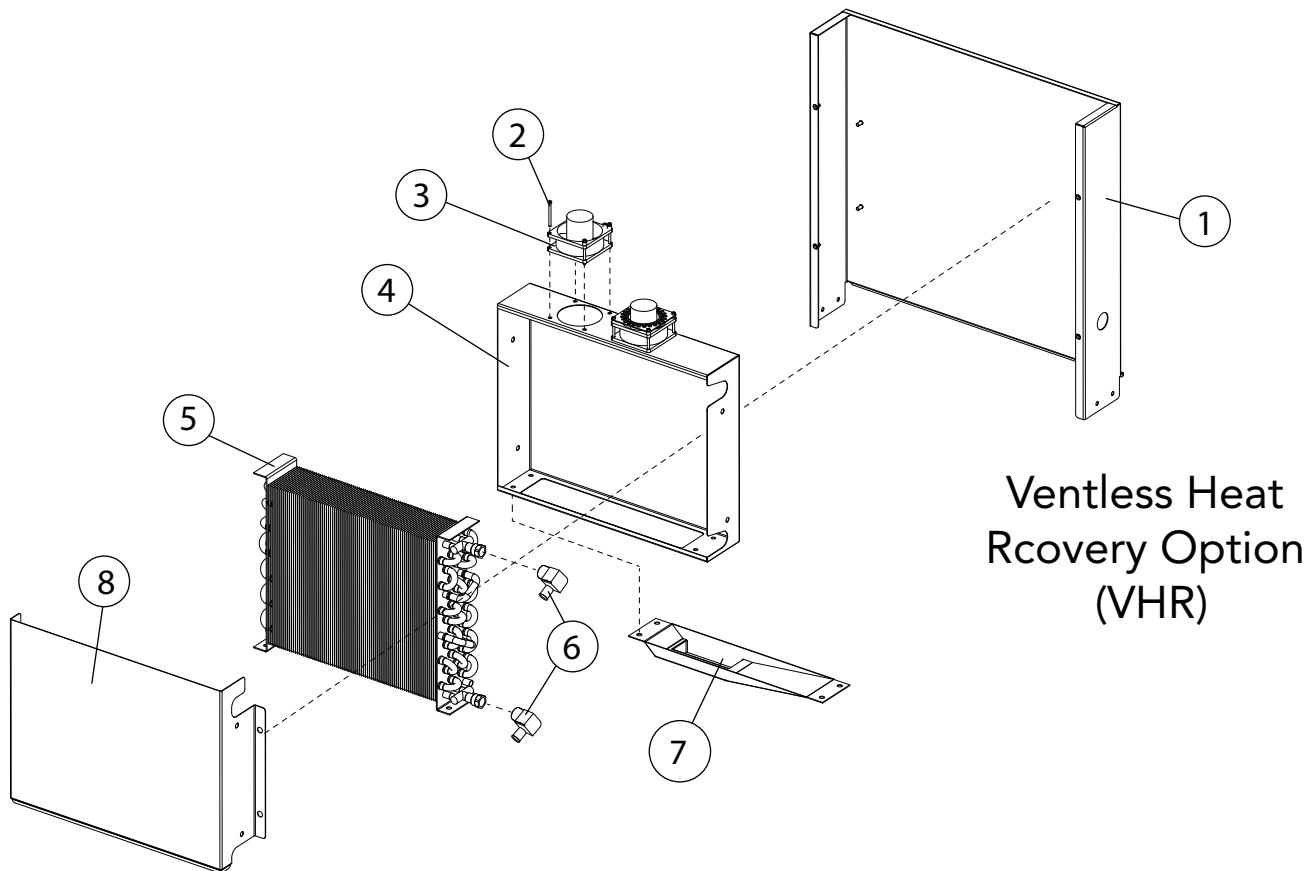

Item No.	Part No.	Description	Qty.
1	336470	SHROUD, EXTERIOR	1
2	114988	SCREW, FILLISTER HEAD, 8-32 X 2" SST	8
3	115438	FAN, 85 CFM AXIAL, 85-265VAC	2
4	336480	SHROUD, COIL	1
5	114931	COIL ASSEMBLY	1
6	108528	BARB, HOSE EL, 1/2" NPT X 1/2 H, BRASS	2
7	334476	PAN, COIL DRAIN WELDMENT	1
8	336486	COVER, REAR	1

Wash Tank Heat, Pump Hoses, Drain Valve, and Screens

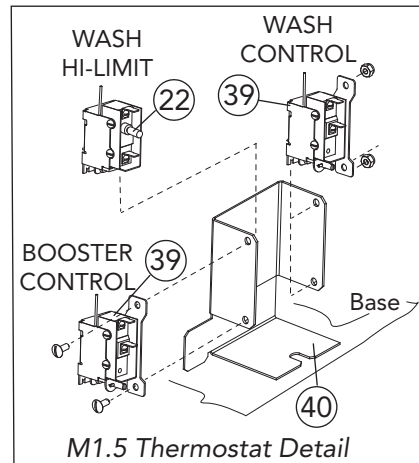
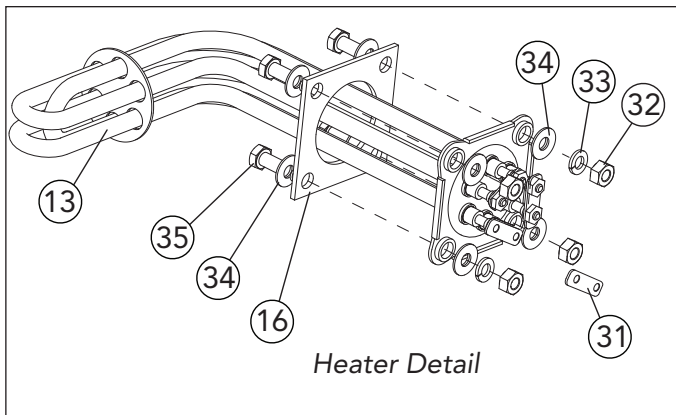
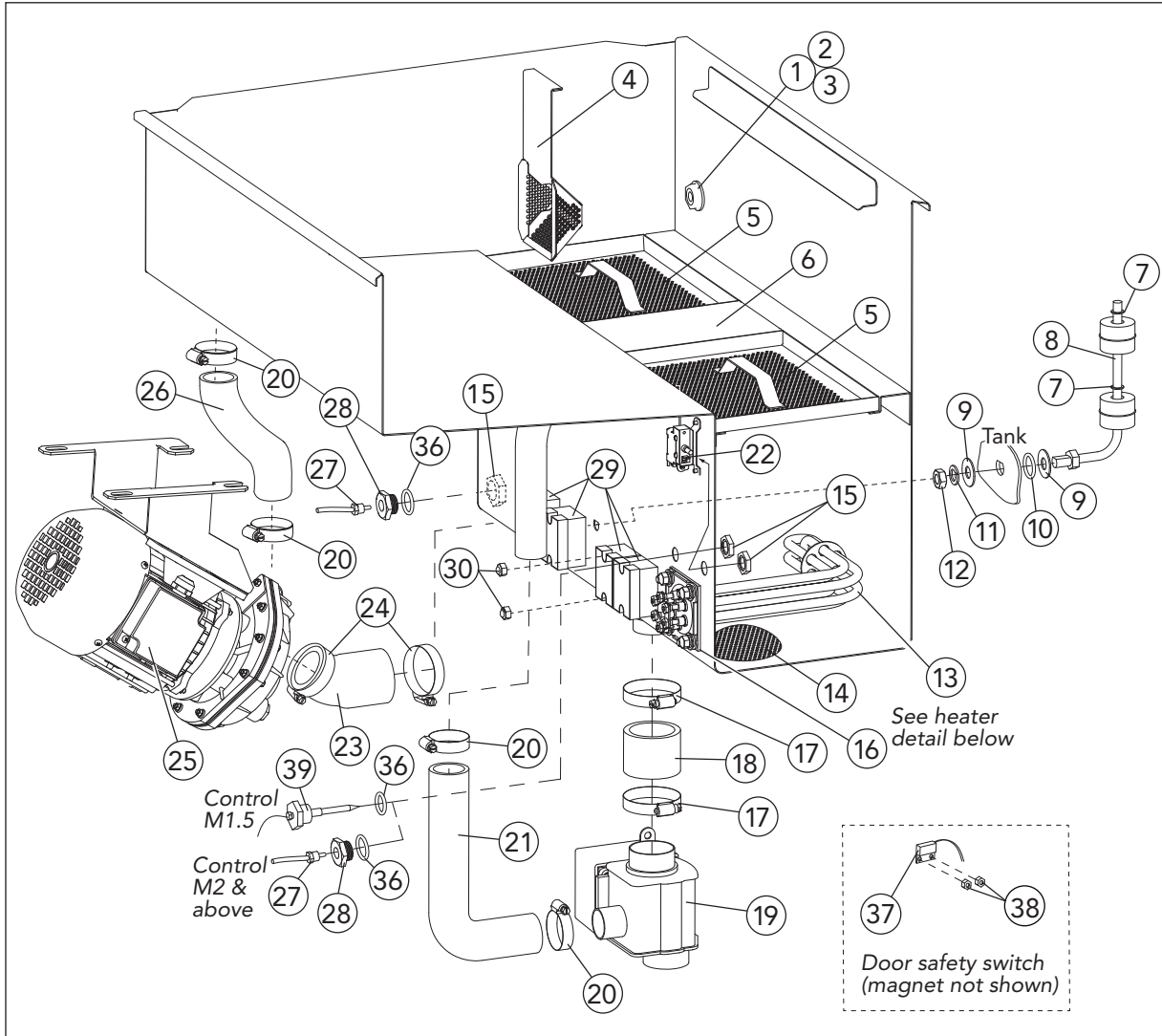

Wash Tank Heat, Pump Hoses, Drain Valve, and Screens

Item No.	Part No.	Description	Qty.
1	109034	GASKET, 1/2" PLUG	1
2	108417	NUT, 1/2" NPT PLASTIC	1
3	108418	PLUG, 1/2" NPT PLASTIC	1
4	333021	SCREEN, PUMP SUCTION	1
5	305164	SCREEN, SCRAP	2
6	332544	SUPPORT, FILLER SCREEN	1
7	111151	C-CLIP	2
8	113291	FLOAT SWITCH, DUAL	1
9	115490	WASHER, FLAT	2
10	115430	O-RING, SILICONE	1
11	107589	WASHER, LOCK, 1/2" SPLIT SST	1
12	107089	NUT, JAM, 1/2-13	1
13	114178	ELEMENT, HEATER 5.2 kW, 208-240,380-415/60/1-3, 90°	1
—	114179	ELEMENT, HEATER 5.2 kW, 480/60/3, 90°	1
14	304816	STRAINER, DRAIN, 6" DIA.	1
15	100547	LOCKNUT, 1/2" NPT SST, FORGED	2
16	108345	GASKET, ELEMENT, 3" X 3" X 1/8" X 2" HOLE	1
17	104165	CLAMP, HOSE M40 SST W/CS SCREW	2
18	205990	HOSE, DRAIN 2" ID X 1-9/16" LG.	1
19	114471	VALVE, DRAIN, ELECTRIC W/COVER	1
20	107340	CLAMP, HOSE M28 SST W/CS SCREW	4
21	114472	HOSE, OVERFLOW, 90°	1
22	110561	THERMOSTAT, FIXED HI-LIMIT 240°F, WASH TANK (M2 ONLY)	1
23	115425	HOSE, SUCTION	1
24	104203	CLAMP, HOSE M52 SST W/CS SCREW	2
25	—	SEE PUMP/MOTOR PARTS BREAKDOWN ON PG. 8	1
26	114863	HOSE, DISCHARGE	1
27	114435	THERMISTOR, 10kΩ	2
28	115530	ADAPTER	2
29	115648	RELAY, SOLID STATE (SSR)	4
30	108954	NUT, 6-32 SST W/NYLON INSERT	6
31	111488	JUMPER, STRIP	3
—	111885	INSULATION, FISH PAPER	1
32	100154	NUT, PLAIN, 5/16-18 SST	4
33	106013	WASHER, LOCK SPLIT, 5/16" SST	4
34	102376	WASHER, FLAT 5/16" SST	4
35	100740	BOLT, HEX 5/16-18 X 1" SST	4
36	115489	O-RING, SILICONE	2
37	113721	SAFETY SWITCH, REED	1
38	108954	NUT, GRIP, 6-32 SST W/NYLON INSERT	2
39	109069	THERMOSTAT, CONTROL 110-195°F (FOR M1.5 ONLY)	2
40	334231	BRACKET, THERMOSTAT (FOR M1.5 ONLY)	1
—	113937	MAGNET, DOOR SAFETY SWITCH (NOT SHOWN)	1

Hood and Handle

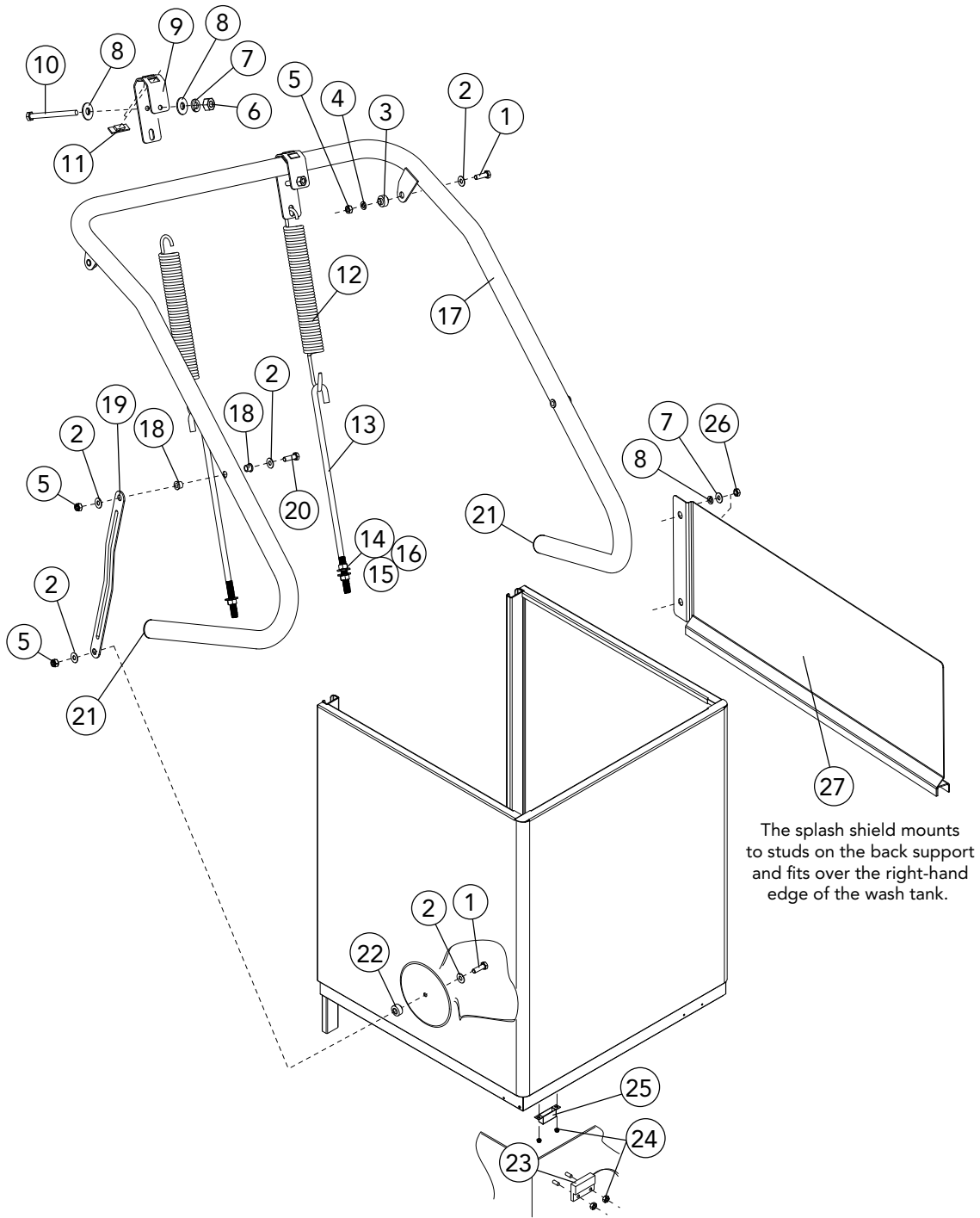

Item No.	Part No.	Description	Qty.
1	100742	BOLT, HEX HD., 5/16-18 X 2" SST	4
2	102376	WASHER, FLAT 5/16" SST	10
3	116232	BUSHING, LIFT HANDLE	2
4	106013	WASHER, LOCK SPLIT 5/16"	2
5	100154	NUT, PLAIN, 5/16-18 SST	8
6	100003	NUT, HEX HD., PLAIN 1/4-20 SST	2
7	106026	WASHER, FLAT 1/4" SST	6
8	106482	WASHER, LOCK SPLIT 1/4" SST	6
9	336434	BRACKET. SPRING	2
10	106028	BOLT, HEX HD., 1/4-20 X 2-1/2" SST	2
11	115637	BUSHING, LIFT HANDLE	4
12	0510459	SPRING, DOOR	2
13	116231	J-BOLT, 3/8-16 X 14" LONG	2
14	100140	NUT, HEX HD. PLAIN, 3/8-16 SST	4
15	104618	WASHER, FLAT 3/8" SST	4
16	106407	WASHER, LOCK, SPLIT 3/8" SST	4
17	115503	HANDLE, LIFT ARM	1
18	116275	BEARING, FLANGED SLEEVED, BRONZE OIL	4
19	115641	LINK, ARM	2
20	100894	BOLT, HEX HD., 5/16-18 X 2-1/4" SST	2
21	115627	END CAP, LIFT HANDLE	2
22	0509264	BUSHING, DOOR	2
23	113721	SWITCH, REED SAFETY	1
24	108954	NUT, GRIP, 6-32 SST W/NYLON INSERT	4
25	113937	MAGNET, SAFETY SWITCH	1
26	107967	NUT, GRIP, 1/4-20 W/NYLON INSERT SST	2
27*	337031	SHIELD, SPLASH (OPTIONAL)	1

*NOTE: THE OPTIONAL SPLASH SHIELD IS USED FOR CORNER INSTALLATIONS. IT BOLTS TO THE BACK SUPPORT AND FITS OVER THE RIGHT-HAND EDGE OF THE WASH TANK. INSTALL THE SPLASH SHIELD BEFORE THE MACHINE IS PLACED IN ITS PERMANENT LOCATION.

Back Support and Guides

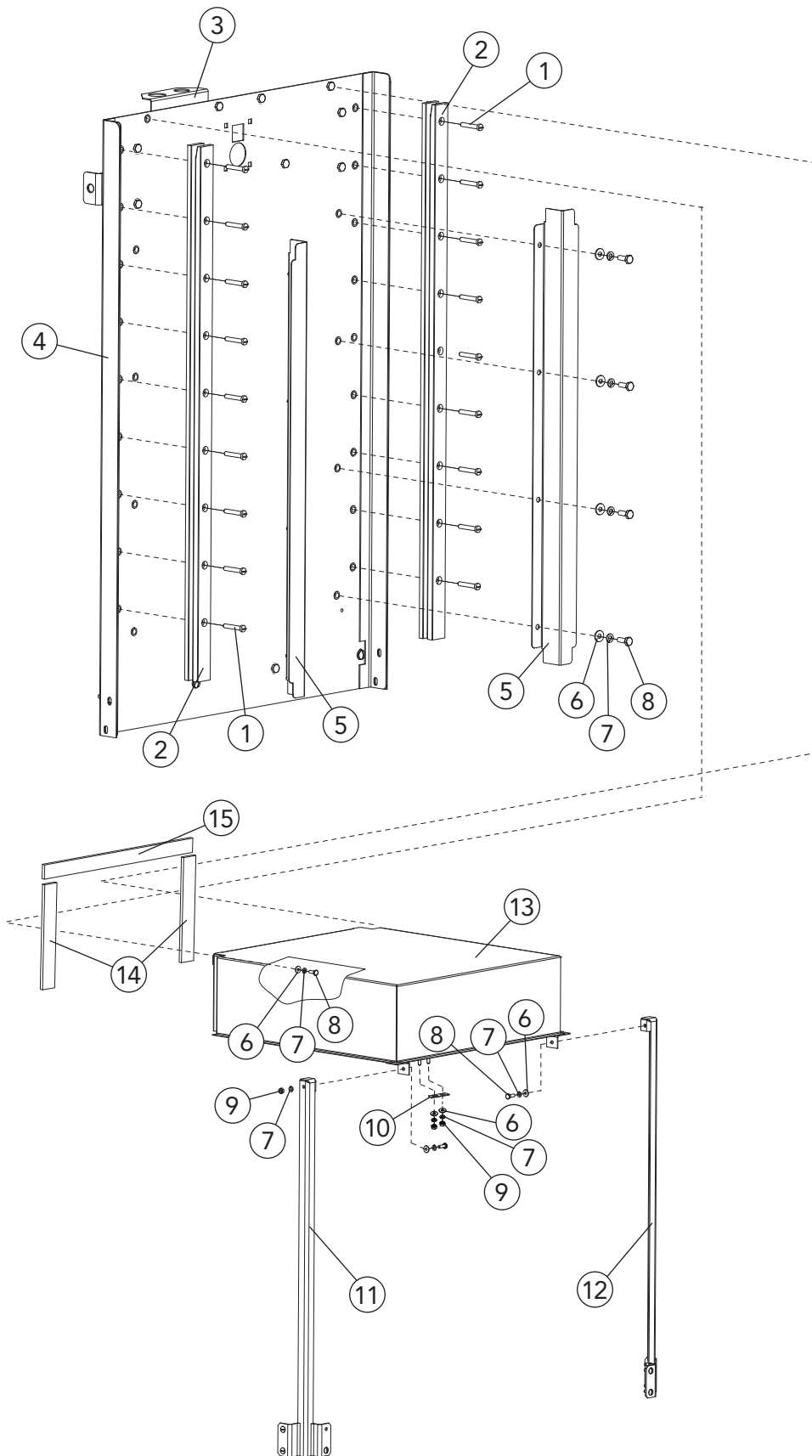

Item No.	Part No.	Description	Qty.
1	114866	SCREW, 1/4-20 X 1-1/2" FILLISTER HEAD SST	18
2	114886	GUIDE, HOOD	2
3	336893	BRACKET, VACUUM BREAKER	1
4	336135	SUPPORT, BACK	1
5	334621	BAFFLE, DEFLECTOR HOOD	2
6	106026	WASHER, FLAT 1/4" SST	30
7	106482	WASHER, LOCK SPLIT 1/4" SST	30
8	100736	BOLT, HEX HD. 1/4-20 X 3/4" SST	26
9	100003	NUT, PLAIN 1/4-20 SST	4
10	116425	GUIDE, HOOD STATIONARY	2
11	336966	UPRIGHT, SUPPORT LH	1
12	336967	UPRIGHT, SUPPORT RH	1
13	336913	TOP, HOOD WELDMENT	1
14	207316	GASKET, 5-1/4" LG. X 3/4" W. X 1/8" THK.	2
15	207315	GASKET, 20-1/4" LG. X 3/4" W. X 1/8" THK.	1

Drain Water Tempering

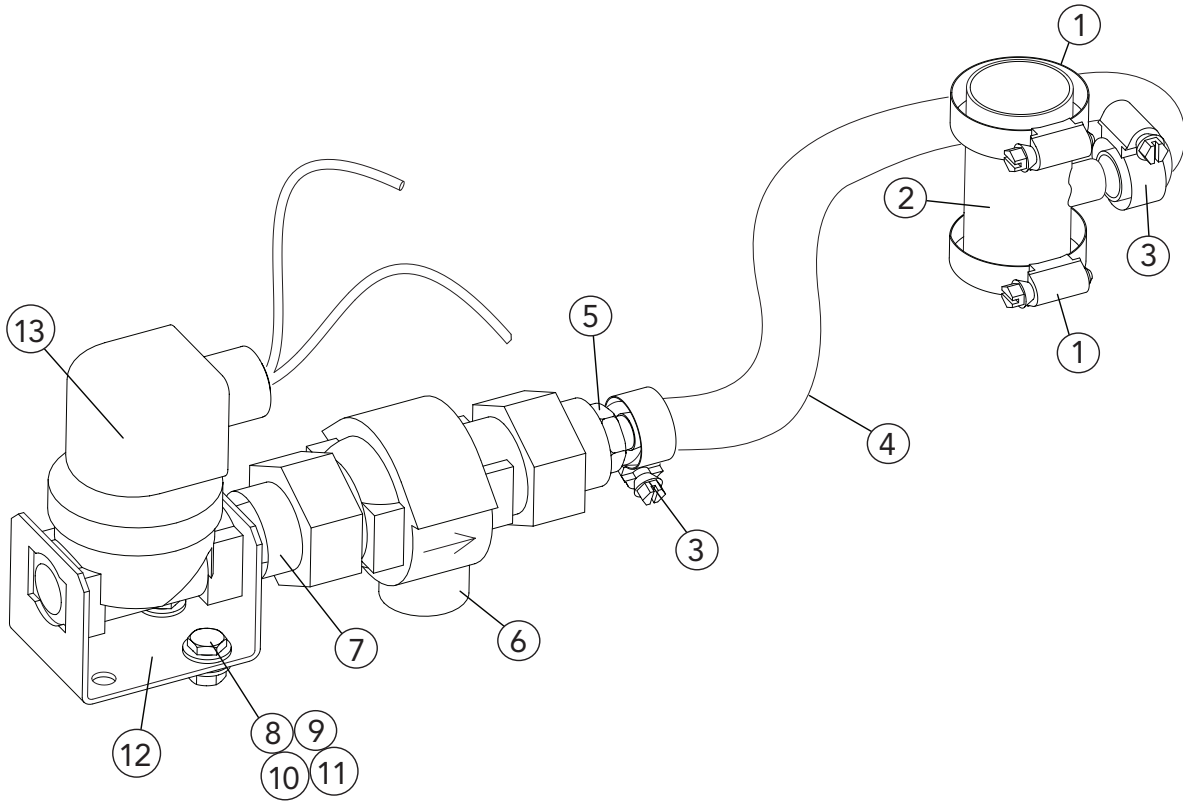

Item No.	Part No.	Description	Qty.
1	107340	CLAMP, HOSE M28 SST, GEAR-TYPE	2
2	333280	TEE, WELDMENT 1-3/8" X 1/2" BARB X 1-3/8"	1
3	105994	CLAMP, HOSE GEAR-TYPE SST	2
4	107417	1/2" I.D. RUBBER, REINFORCED (CUT TO FIT)	5 FT.
5	107419	BARB, HOSE ST. 1/2" NPT X 1/2" HOSE BRASS	1
6	110551	PREVENTER, BACKFLOW 1/2" NPT BRASS	1
7	100209	NIPPLE, 1/2" NPT CLOSE BRASS	1
8	100734	BOLT, HEX HD. 1/4-20 X 1/2" SST	2
9	106026	WASHER, FLAT 1/4" SST	2
10	106482	WASHER, LOCK SPLIT 1/4" SST	2
11	100003	NUT, PLAIN 1/4-20 SST	2
12	0312146	BRACKET, VALVE FWR	1
13	109886	VALVE, SOLENOID 1/2" 120VAC COIL	1
–	109902	KIT, REPAIR 1/2" SOLENOID VALVE	A/R
–	108516	COIL, 120VAC 1/2" SOLENOID VALVE	A/R

Hot Water Coil Heat

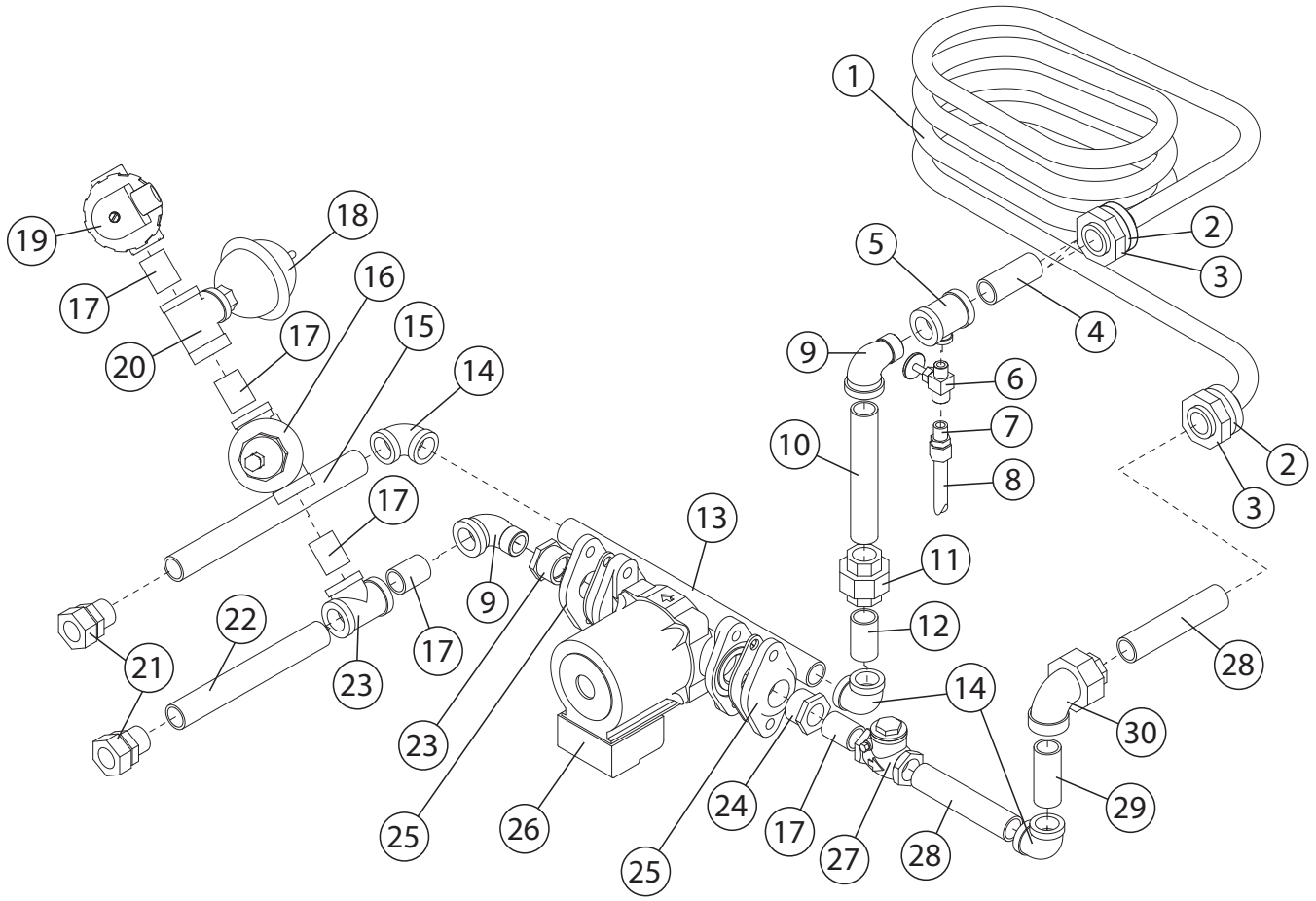

Item No.	Part No.	Description	Qty.
1	334640	COIL, HOT WATER	1
2	109303	GASKET	1
3	100585	LOCKNUT, 1" NPT BRASS	2
4	100461	NIPPLE, 3/4" NPT X 1-1/4" LG. BRASS	1
5	107418	TEE, REDUCING, 3/4" NPT X 3/4" NPT X 1/4" NPT BRASS	1
6	112437	VALVE, NEEDLE	1
7	107065	ADAPTER, 1/4" OD X 1/4" MPT PLASTIC	1
8	107414	TUBING, HIGH DENSITY 1/4"	4 FT.
9	102444	ELBOW, STREET 3/4" NPT X 90° BRASS	2
10	102662	NIPPLE, 3/4" NPT X 6-1/2" LG. BRASS	1
11	100571	UNION, 3/4" NPT BRASS	1
12	100208	NIPPLE, RTOE 3/4" NPT X 1-3/4" LG. BRASS	1
13	102683	NIPPLE, 3/4" NPT X 13-1/2" LG. BRASS	1
14	102442	ELBOW, 3/4" NPT X 90° BRASS	3
15	102676	NIPPLE, 3/4" NPT X 10-1/2" LG. BRASS	1
16	107550	VALVE, PRESSURE REGULATING, 3/4" NPT BRASS	1
17	100184	NIPPLE, 3/4" NPT X CLOSE BRASS	4
18	104681	SILENCER, 1/2" NPT	1
19	111437	VALVE, SOLENOID 3/4" NPT HW	1
—	114839	KIT, REPAIR VALVE, 3/4" HW	A/R
—	111472	COIL, SOLENOID, 3/4" 120VAC	A/R
20	102526	TEE, REDUCER 3/4" NPT X 3/4" NPT X 1/2" NPT	1
21	100571	UNION 3/4" NPT BRASS	2
22	102658	NIPPLE, 3/4" NPT X 5-1/2" LG. BRASS	1
23	102521	TEE, 3/4" NPT X BRASS	1
24	102396	BUSHING, REDUCING, 1" NPT X 3/4" NPT BRASS	2
25	111860	FLANGE SET, GRUNDFOSS PUMP	2
26	111854	PUMP, GRUNDFOSS HW RECIRCULATOR BRONZE	1
27	100853	VALVE, CHECK 3/4" NPT BRONZE	1
28	102490	NIPPLE, 3/4" NPT X 3-1/2" LG. BRASS	2
29	102489	NIPPLE, 3/4" NPT X 2-1/2" LG. BRASS	1
30	106911	UNION, ELBOW 3/4" NPT FEMALE BRASS	1

Dish Racks, Line Strainer, PRV

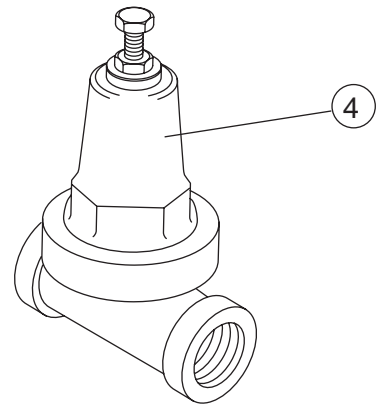
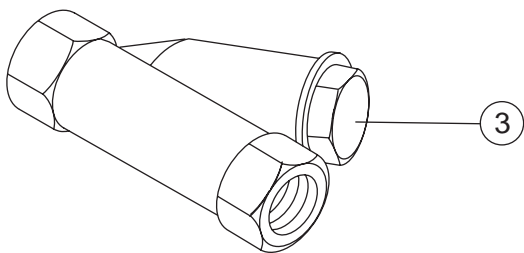
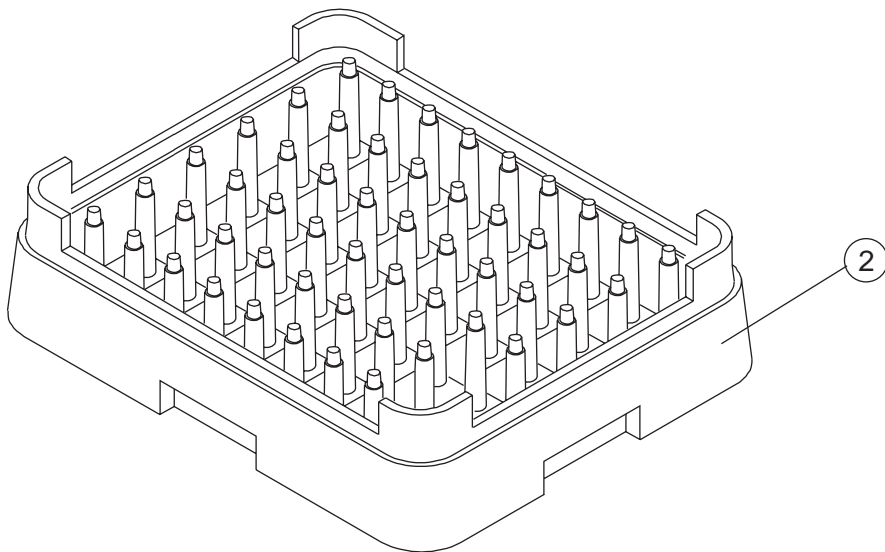
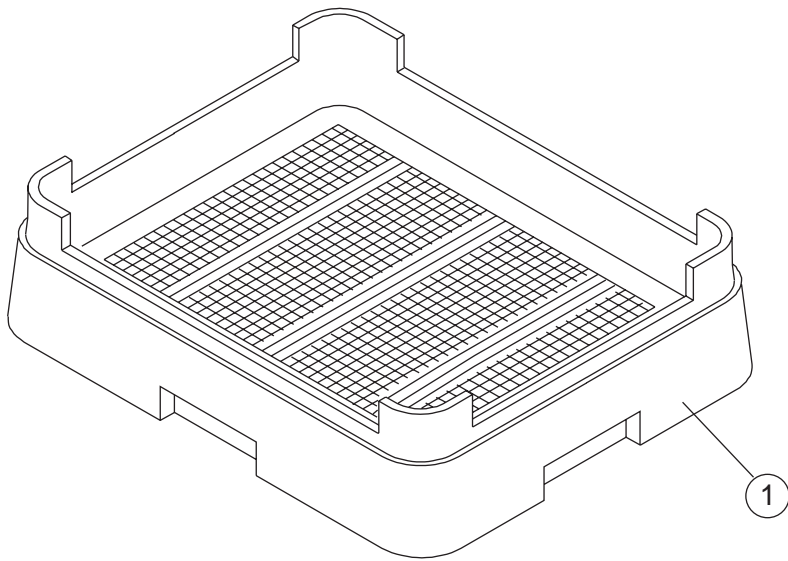

Item No.	Part No.	Description	Qty.
1	101273	DISH RACK, FLAT-BOTTOM	A/R
2	101285	DISH RACK, PEG	A/R
3	110768	STRAINER, LINE 3/4" NPT BRONZE	1
4	107550	VALVE, PRESSURE. REGULATING 3/4" NPT BRONZE	1

***This Page
Intentionally
Left Blank***