

bi·line **VORTEX WASH SYSTEM**

Installation, Operation, Cleaning, and Replacement Parts



Vortex
Wash System

Model: VWS



Issue Date: 1.15.25

Manual P/N 117309 rev. C

For machines beginning with VWS21040031 and above

www.bilineconveyors.com

3765 Champion Boulevard
Winston-Salem, NC 27105
(336) 661-1556 Fax: (336) 661-1979
Toll-free: (800) 858-4477

2674 N. Service Road, Jordan Station
Ontario, Canada L0R 1S0
(905) 562-4195 Fax: (905) 562-4618
Toll-free: (800) 263-5798

Printed in the USA

National Service Department

In Canada:

Toll-free: (800) 263-5798

Tel: (905) 562-4195

Fax: (905) 562-4618

In the USA:

Toll-free: (800) 858-4477

Tel: (336) 661-1556

Fax: (336) 661-1660

ATTENTION:

The model no., serial no., voltage, Hz and phase are needed to identify your machine and to answer questions.

**The machine data plate
is located on the side of the
control cabinet.**

Please have this information ready if you call for service assistance.

Three ways to REGISTER YOUR PRODUCT and ACTIVATE YOUR WARRANTY.

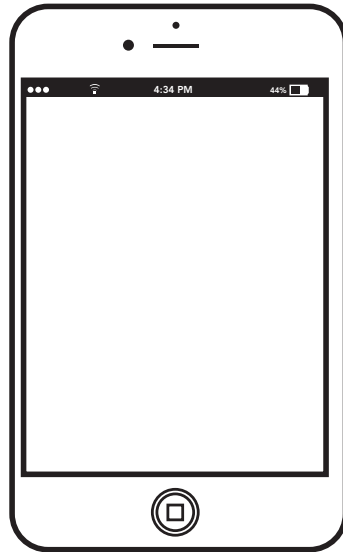

- Use your mobile phone and scan the QR code on the front of the control cabinet to access the URL <http://biline.us/VWS> and register your product
- or
- Go to our website at <http://www.bilineconveyors.com/registration> and register your product
- or
- Use the fax form on the next page.

PRODUCT REGISTRATION BY FAX

COMPLETE THIS FORM AND FAX TO:

(336) 661-1660 in the USA

1-(800) 204-0109 in Canada

PRODUCT REGISTRATION CARD

Model	Serial #
-------	----------

Date of Installation: ___/___/___

Company Name: _____

Address: _____
(Street) (State) Province (Zip) Postal Code

Telephone #: () _____ --- _____

Contact: _____

Installation Company: _____

Address: _____

Telephone #: _____

Contact: _____

FAILURE TO REGISTER YOUR PRODUCT MAY VOID YOUR WARRANTY

IMPORTANT IMPORTANT

Revision History

Specifications are subject to change based on continual product improvement. Sink owners may request a manual by calling 1(800) 858-4477 in the USA and 1(800) 263-5798 in Canada.

Revision Date	Revised Pages	Serial Number Effectivity	Description
6.1.21	All	VWS21040031	Released First Edition
7.30.21	9,13	VWS21040031	Revised Change Water Alarm from two to four hours.
6.29.22	10	All	Revised Item 5: tank heater energizes when water reaches low water sensor
1.15.25	5	All	Revised Fig.11, Machine assembly, illustrating the sheet pan rack assembly
	10	All	Revised Fig.19 and Fig. 20 illustrating the sheet pan rack assembly.
	26-27	All	Deleted Items 7,7a,8,8a rack weldments. Replaced with new Item 7, 8-piece sheet pan rack. weldment.

Limited Warranty

LIMITED WARRANTY

Biline Conveyor Systems (herein referred to as "The Company"), 3765 Champion Blvd., Winston-Salem, North Carolina 27105, and 2674 N. Service Road, Jordan Station, Ontario, Canada, L0R 1S0, warrants machines, and parts, as set out below:

Warranty of Machines: The Company warrants all new machines of its manufacture bearing the name "Biline" and installed within the United States and Canada to be free from defects in material and workmanship for a period of one (1) year after the date of installation or fifteen (15) months after the date of shipment by The Company, whichever occurs first. [See below for special provisions relating to glasswashers.] Warranty registration must be submitted to The Company within ten (10) days after installation either online at Biline website (<http://www.bilineconveyors.com/registration>) or by the fax form at the front of this manual. The Company will not assume any responsibility for extra costs for installation in any area where there are jurisdictional problems with local trades or unions.

If a defect in workmanship or material is found to exist within the warranty period, The Company, at its election, will either repair or replace the defective part or accept return of the machine for full credit; provided; however, as to glasswashers, The Company's obligation with respect to labor associated with any repairs shall end (a) 120 days after shipment, or (b) 90 days after installation, whichever occurs first. In the event that The Company elects to repair, the labor and work to be performed in connection with the warranty shall be done during regular working hours by a Biline authorized service technician. Defective parts become the property of The Company. Use of replacement parts not authorized by The Company will relieve The Company of all further liability in connection with its warranty. In no event will The Company's warranty obligation exceed The Company's charge for the machine. The following are not covered by The Company's warranty:

- a. Lighting of gas pilots or burners.
- b. Cleaning of gas lines.
- c. Replacement of fuses or resetting of overload breakers.
- d. Adjustment of thermostats.
- e. Adjustment of clutches.
- f. Opening or closing of utility supply valves or switching of electrical supply current.
- g. Cleaning of valves, strainers, screens, nozzles, or spray pipes.
- h. Performance of regular maintenance and cleaning as outlined in the operator's guide.
- i. Damages resulting from water conditions, accidents, alterations, improper use, abuse, tampering, improper installation, or failure to follow maintenance and operation procedures.
- j. Wear on Pulper cutter blocks, pulse vanes, and auger brush.

Examples of the defects not covered by warranty include, but are not limited to: (1) Damage to the exterior or interior finish as a result of the above, (2) Use with utility service other than that designated on the rating plate, (3) Improper connection to utility service, (4) Inadequate or excessive water pressure, (5) Corrosion from chemicals dispensed in excess of recommended concentrations, (6) Failure of electrical components due to connection of chemical dispensing equipment installed by others, (7) Leaks or damage resulting from such leaks caused by the installer, including those at machine table connections or by connection of chemical dispensing equipment installed by others, (8) Failure to comply with local building codes, (9) Damage caused by labor dispute.

Warranty of Parts: The Company warrants all new machine parts produced or authorized by The Company to be free from defects in material and workmanship for a period of 90 days from date of invoice. If any defect in material and workmanship is found to exist within the warranty period The Company will replace the defective part without charge.

DISCLAIMER OF WARRANTIES AND LIMITATIONS OF LIABILITY. THE COMPANY'S WARRANTY IS ONLY TO THE EXTENT REFLECTED ABOVE. THE COMPANY MAKES NO OTHER WARRANTIES, EXPRESS OR IMPLIED, INCLUDING, BUT NOT LIMITED, TO ANY WARRANTY OF MERCHANTABILITY, OR FITNESS OF PURPOSE. THE COMPANY SHALL NOT BE LIABLE FOR INCIDENTAL OR CONSEQUENTIAL DAMAGES. THE REMEDIES SET OUT ABOVE ARE THE EXCLUSIVE REMEDIES FOR ANY DEFECTS FOUND TO EXIST IN THE COMPANY'S MACHINES AND THE COMPANY'S PARTS, AND ALL OTHER REMEDIES ARE EXCLUDED, INCLUDING ANY LIABILITY FOR INCIDENTALS OR CONSEQUENTIAL DAMAGES.

The Company does not authorize any other person, including persons who deal in Biline Conveyor System machines to change this warranty or create any other obligation in connection with Biline Conveyor System machines.

INSTALLATION CODES

The installation of the machine must comply with all local electrical, plumbing, health, and safety codes or in the absence of local codes, installed in accordance with the applicable requirements in the National Electrical Code, NFPA 70, Canadian Electrical Code (CEC), Part 1, CSA C22.1; and the Standard for Ventilation Control and Fire Protection of Commercial Cooking Operations, NFPA 96.

**NOTE:**

Only qualified personnel familiar with the installation of food service equipment should attempt the installation of this machine. Damage or problems associated with improper installation will not be covered by the limited warranty.

SAFETY SYMBOLS

The following symbols are used in this manual for important information.

**WARNING:**

Warning statements indicate a condition or practice that may result in serious injury.

**CAUTION:**

Caution statements indicate a condition or practice that may result in damage to the machine.

**NOTE:**

Note statements indicate information necessary for the operation of the machine.

Model Description

208-240V/60/1 and 3 PH

14 gauge, Type 304 stainless tanks and drainboards

Twist-handle drain valves

Stainless steel legs, cross-rails, and adjustable bullet-feet

3 HP on 3 PH, 2 HP on 1 PH: Stainless steel wash pump and impeller with permanently sealed bearings

Rear discharge

Removable strainer plates

Manual reset motor overload protection

Low water protection for wash pump

5 kW wash tank heater

Options and Accessories

480/60/3

Utensil basket

Folding wash tank cover

Sheet pan racking system

Drying rack

Pot and pan overshelf with hooks

Table mounted overshelf

1/2" pre-rinse sprayer

3/4" faucet

Left-to-right or right-to-left direction of operation

Detergent Requirement

- **USE A NON-CHLORINATED COMMERCIAL GRADE DETERGENT.**



**Follow the chemical supplier's instructions.
Wear gloves, apron, and eye protection when handling chemicals.**

Table of Contents

Revision History	i
Limited Warranty	ii
Installation Codes.....	iii
Model Description.....	iv
Detergent Requirement	iv
Moving the Sink	vi
Installation	1
Receiving	1
Placement.....	1
Sink Construction	2
Water Connections.....	3
Drain Connections.....	4
Electrical Connection	5
Machine Assembly	6
Wash Tank Water Level Sensor	8
Run Timer	8
Operation	9
Control Panel.....	9
Start Sequence	10
Loading and Cleaning Wares	11
Alarm Conditions	13
Cleaning and Maintenance	14
Service Replacement Parts	15

MOVING THE SINK:

- Check the travel route, especially doors and passageways, to ensure safe movement of the sink.
 - Casters, (supplied by others), are recommended to move the sink.
 - Compare installation site utility connections to ensure they match machine requirements.
1. Employ a minimum of four persons to move by hand.
 2. Lift the pump side of the sink off the pallet to the floor.
 3. Lift the other side of the sink making sure to keep sink balanced.
 4. Slide the pallet away from the sink.
 5. Place the sink in the final location and level it front-to-back and side-to-side using the adjustable feet.
 6. Accessories are stowed inside the machine. Remove and place in a secure location for later assembly.

SINK REAR

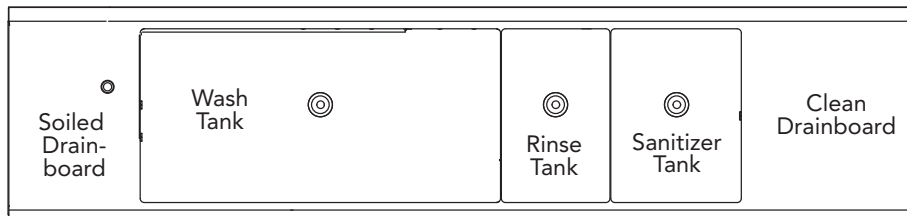

SINK FRONT

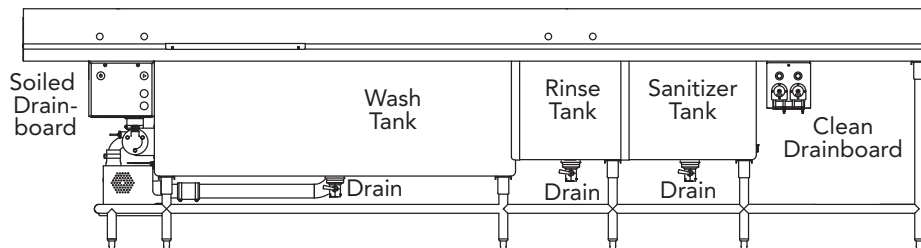

SINK FRONT

RECEIVING



1. Inspect the machine and immediately report damage to a supervisor.
2. Save all packing materials until the carrier inspects the machine.
3. Check the inside of sink for accessories and installation kits.
4. Register your machine by scanning the QR code on the machine, by fax or at www.bilineconveyors.com/registration as soon as possible.



CAUTION:

Be careful when removing sink from pallet. Check doorway and hall clearances before moving the sink.

PLACEMENT

1. Ensure site utilities match machine specifications.
2. Do not remove utility installation tags before installation is complete.
3. Place the machine in its permanent location.
4. Adjust the height and level of the machine using the adjustable legs. Level the machine from side-to-side and front-to-back.
5. Locate accessories shipped inside the machine or in separate containers.
6. Remove machine protective film.
7. Local code may require that the sink back splash be sealed to the wall with sealant.

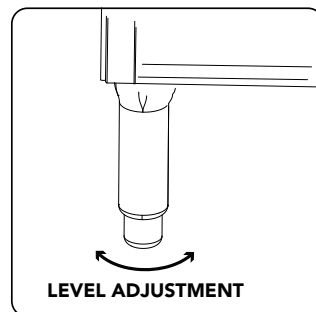

Fig. 1 - Leg adjustment.



NOTE:

Do not remove utility installation tags before installation is complete.

SINK CONSTRUCTION

Standard features include: wash tank, rinse tank, sanitizer tank, drain boards and twist handle drains. Sink and drainboard lengths may vary. Options may include: utensil baskets, wash tank cover, sheet pan racking system, 1/2" pre-rinse sprayer, and 3/4" faucets.

Figure 2 shows a sample sink construction. The VWS is a customizable machine; therefore, your machine may be significantly different than the sample below.

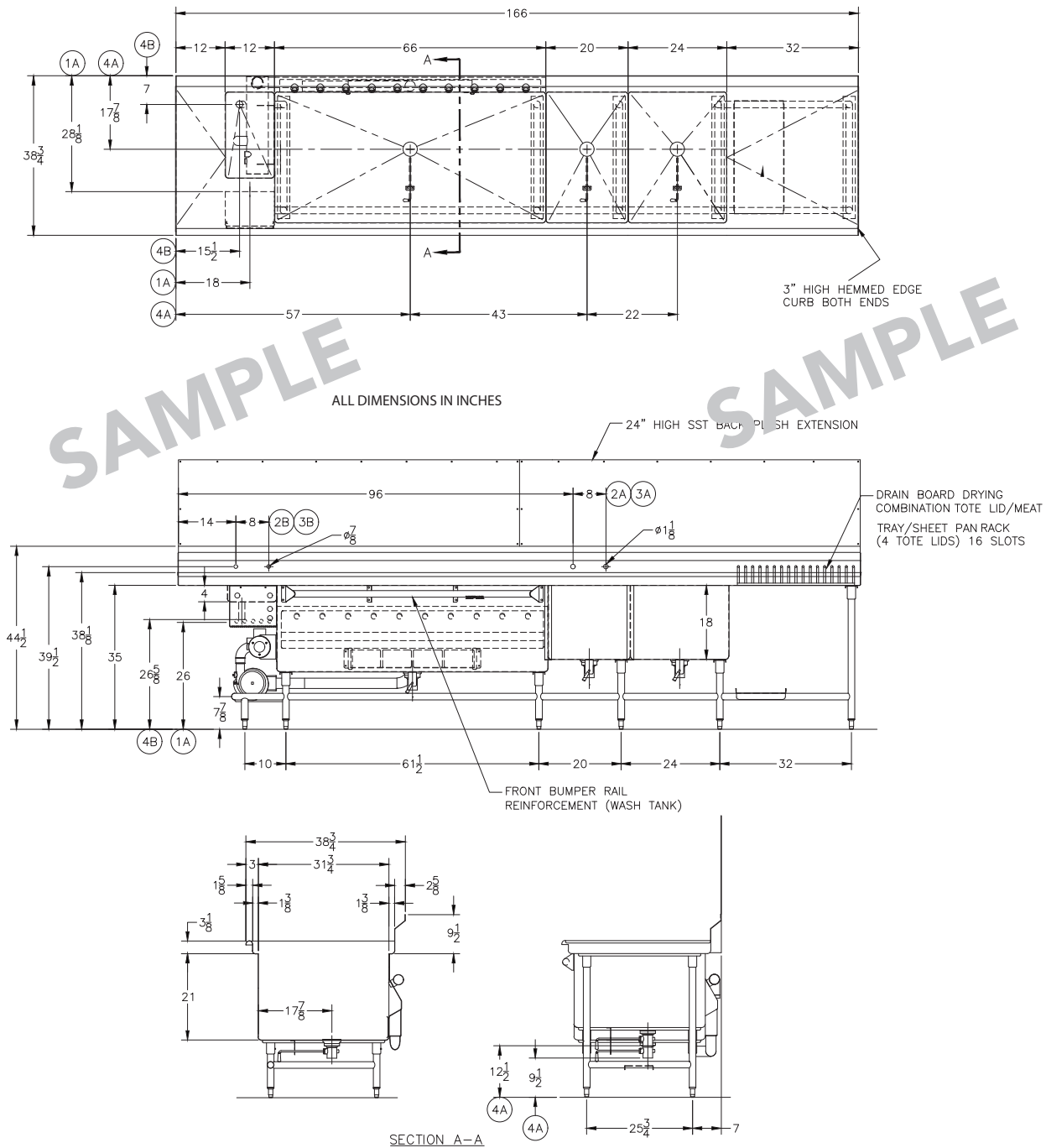

Fig. 2 - Sample sink construction.

WATER CONNECTIONS



CAUTION: The installing plumber must thoroughly flush debris from the water supply lines before connecting to the sink. Damage caused by improper installation is not covered by the limited warranty.



NOTE: Water connections are located on the back wall of the sink.

HOT WATER



FAUCET

- 3/4" NPT HOT WATER SUPPLY
- Minimum 110°F/43°C, Maximum 120°F/48.8°C

PRE-RINSE SPRAYER

- 1/2" NPT HOT WATER SUPPLY
- Minimum 110°F/43°C, Maximum 120°F/48.8°C

RINSE SPRAYER

- 3/4" NPT HOT WATER SUPPLY
- Minimum 110°F/43°C, Maximum 120°F/48.8°C

COLD WATER

FAUCET

- 3/4" NPT COLD WATER SUPPLY
- Minimum 50°F/10°C, Maximum 75°F/23.9°C

PRE-RINSE SPRAYER

- 1/2" NPT COLD WATER SUPPLY
- Minimum 50°F/10°C, Maximum 75°F/23.9°C

RINSE SPRAYER

- 3/4" NPT COLD WATER SUPPLY
- Minimum 50°F/10°C, Maximum 75°F/23.9°C

- WATER HARDNESS OF 3 GRAINS/US GAL - 0.83 IMP GAL - 5.3 MG/L or LESS.
- INSTALL A SHUT-OFF VALVE IN THE WATER SUPPLY LINE AS CLOSE TO THE SINK AS POSSIBLE FOR SERVICING.
- **USE A NON-CHLORINATED COMMERCIAL GRADE DETERGENT.**



Fig. 3 - Sample faucet install.



Fig. 4 -
Sample pre-rinse sprayer install.

DRAIN CONNECTIONS



NOTE: All sinks are gravity drains.

- **SCRAP SINK:** 1-1/2" NPT (OPEN DRAIN) WITH SLIP-FIT TAILPIECE LOCATED UNDER SCRAP SINK.
- **WASH, RINSE, AND SANITIZER TANK DRAIN VALVES:** 1-1/2" NPT.



Fig. 5 -
1-1/2" NPT tank drain valve.
Twist lever shown open.



Fig. 6 -
1-1/2" NPT tank drain valve.
Twist lever shown closed.



Fig. 7 -
1-1/2" scrap sink drain.

ELECTRICAL CONNECTION



WARNING:

Electrocution may occur when working on energized circuits. Disconnect power at the main breaker or service disconnect switch, then lock out and tag the circuit to indicate that work is being performed on the circuit.

To connect incoming power:

1. Remove screws holding control cabinet cover, Fig. 8.
2. Locate input terminal block at top left corner of cabinet, Fig. 9.
3. Check the electrical specs on the Machine Electrical Connection Data Plate, Fig. 10.
4. A knockout is provided at rear of box to run conduit and wires.
5. Connect power wires including ground to the input terminal block.
6. Reverse wires L1 and L2 to change motor rotation.

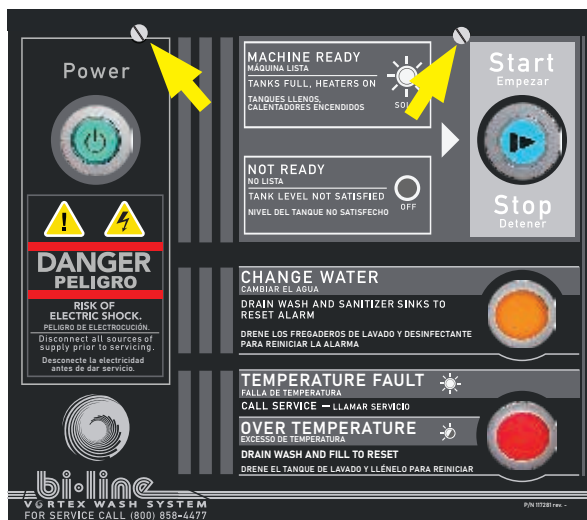

Fig. 8 - Control panel.

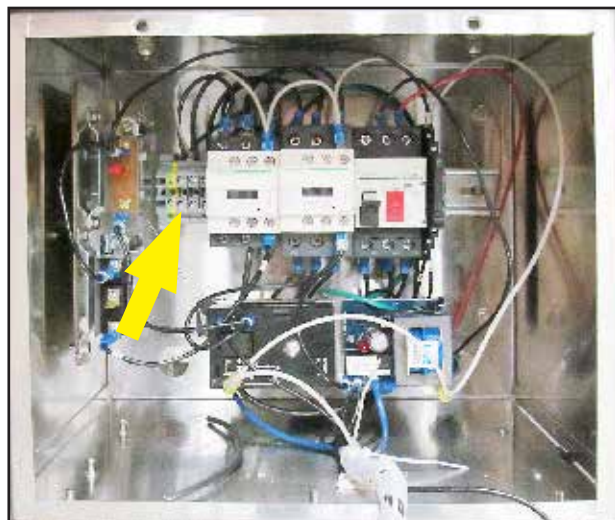
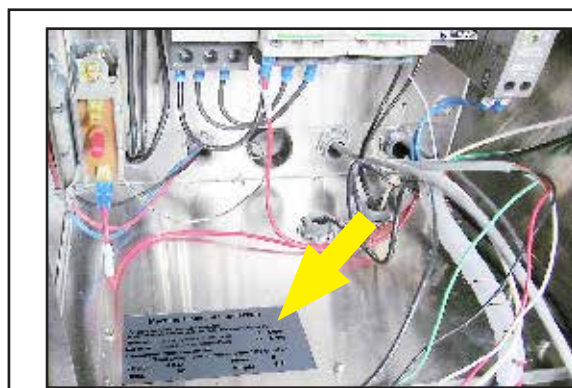

Fig. 9 - Input terminal block.



Machine Electrical Connection	
For supply connection, use copper conductors in accordance with local electrical code, Rated Minimum 90° C (194° F)	
Minimum Supply Conductor Ampacity	15 AMPS
Maximum Supply Overcurrent Protection Device	15 AMPS
Overcurrent Protection Device: Time Delay Fuse or Inverse Time CKT Breaker	
Voltage:	30
Phase:	0
Hermetic Compressor:	11

Fig. 10 - Machine Electrical Connection Data Plate.

Machine Assembly

Machine Assembly:

1. Turn main power and water on.
2. Insert the pump screen into its guides at the back wall of the machine, Fig. 12.
3. Place the scrap screen basket in the scrap sink, Fig. 13.
4. Hang the utensil basket in the wash tank, Fig. 14.
5. Check drain seats for debris. Make sure the drain screens are in place, Fig. 15.
6. Ensure excessive sealing putty has been removed from drain clamping ring, Fig. 15.
7. Ensure drain handles are fully closed, Fig. 5 and 6, page 4.
8. Fill wash tank to the water line mark on the back wall of the wash tank, Fig. 17.
9. Fill the sanitizer tank. Do not fill the rinse tank.

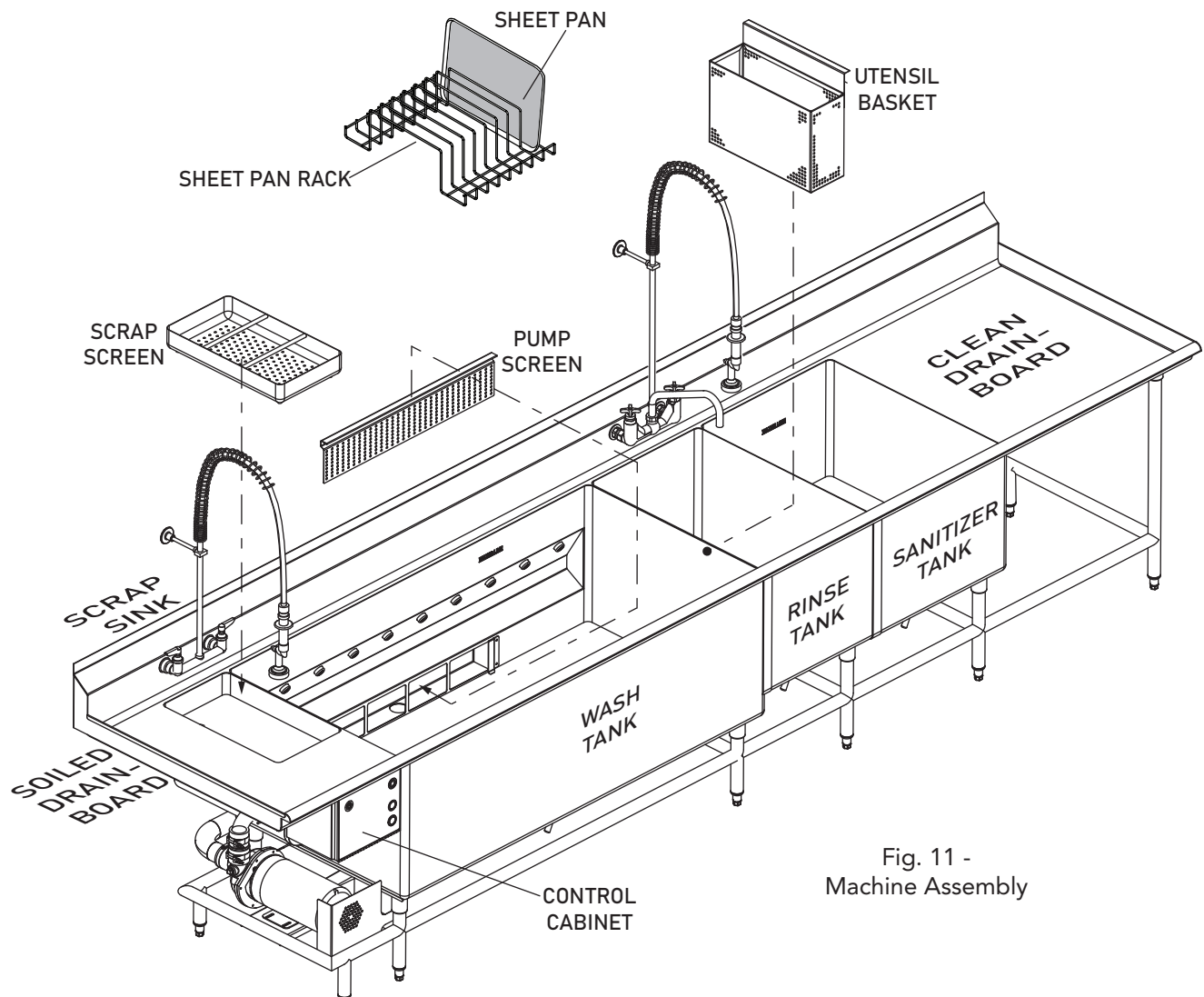

Fig. 11 -
Machine Assembly

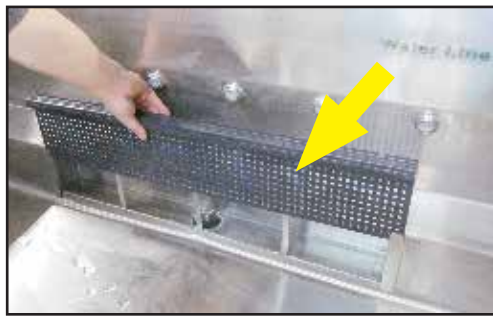

Fig. 12 -
Install wash tank pump screen.



Fig. 13 -
Install scrap screen basket.



Fig. 14 -
Install utensil basket.



Fig. 15 - Check drains seats and screens. Ensure putty has been removed from drain clamping ring.

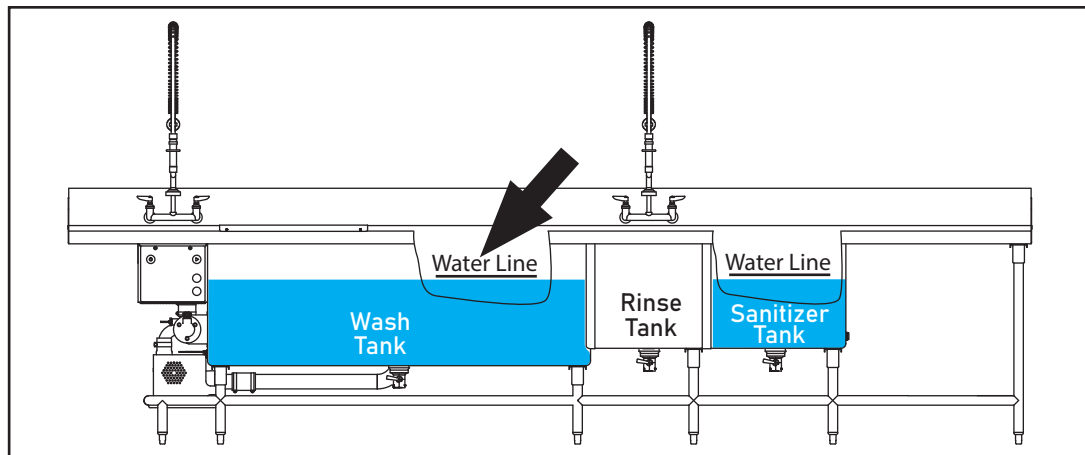

Fig. 16 -
Fill the wash and sanitizer tanks to the WATER LINE mark on back wall of the sink.

WASH TANK WATER LEVEL SENSOR



NOTE: Options change the capacities of the wash, rinse, and sanitizer tanks.
For reference: One US Gallon = 231 in³.

The water level sensor is located in the wash tank and detects the water level in the tank. The tank heater and wash pump will run when the water covers the sensor. They will not run if the water level is below the sensor. The level controller is located in the control cabinet and is not adjustable.

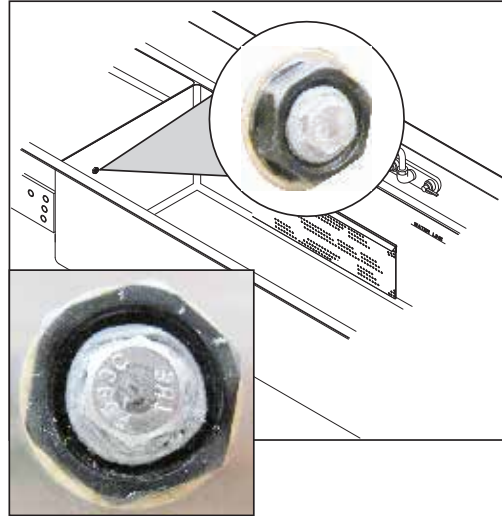

RUN TIMER

The run timer is set at the factory to run four hours and should not be adjusted without first consulting the factory. The timer is located in the control cabinet, Fig. 17.

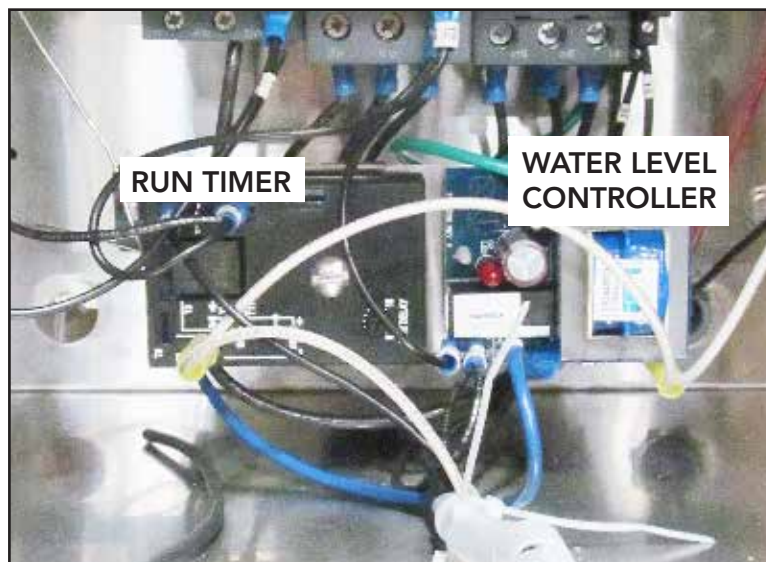
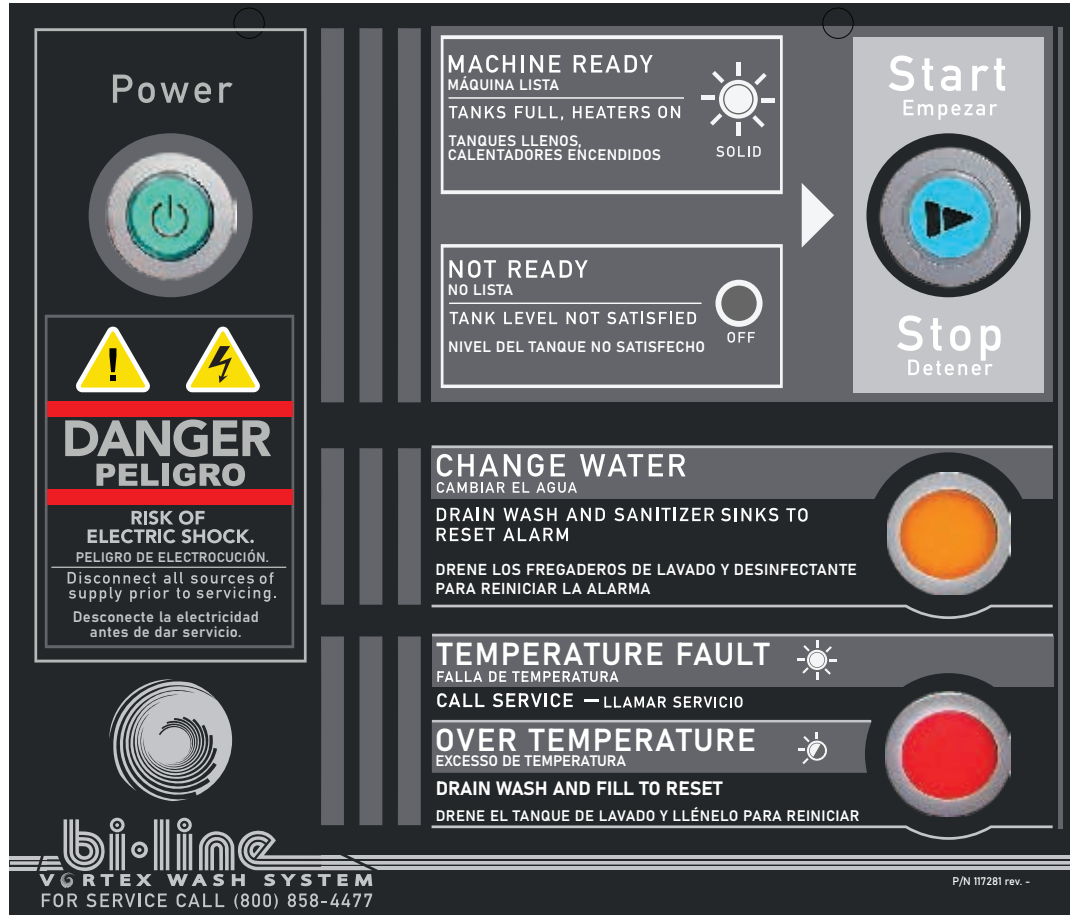

Fig. 17-
Run timer and water level controller.

CONTROL PANEL



CONTROL PANEL INDICATOR LIGHTS





<p>Green Power</p>  <p>Press to turn machine on, button illuminates. Press to turn off, button goes out.</p>	<p>Blue Start/Stop</p>  <p>Button is off if machine not ready. Button on when machine is ready to run.</p> <p>Press to start, light is on solid. Press to stop, button off. (The button is off if machine is drained).</p>
<p>Amber Change Water</p>  <p>Light comes when machine has been on for four hours.</p>	<p>Red Temperature Fault</p>  <p>Light comes on solid when a problem occurs in the temperature control circuit. Tank heat is inoperative.</p> <p>Operator must call an authorized service agent as soon as possible.</p>

Fig. 18 - Control panel indicators

Operation

START SEQUENCE

1. Turn building water and main power on.
2. Close the tank drains.
3. Place the sheet pan rack in the wash sink if desired.
4. Fill the wash, rinse, and sanitizer tanks to the WATER LINE marks. Hot water, minimum 110°F/43.3°C, maximum 120°F/48.8°C.
5. The tank heater comes on when water reaches the low water sensor. .
6. A non-chlorinated commercial detergent is required. Use sanitizer to the according to the chemical supplier's instructions.
7. Press the POWER BUTTON. It will illuminate.
8. Press the START button. The button illuminates and the pump runs.
9. Begin processing wares.

LOADING and CLEANING WARES

Loading Sheet Pans



Fig. 19 -
Sheet Pan Rack placed in wash tank



Fig. 20 -
Insert one sheet pan per slot.

1. Position the sheet pan rack in the center of the wash tank, Fig. 19.
2. Insert one sheet pan in each slot of the rack, Fig. 20.

LOADING and CLEANING WARES

2. Flush large food particles off the wares in the scrap sink section.

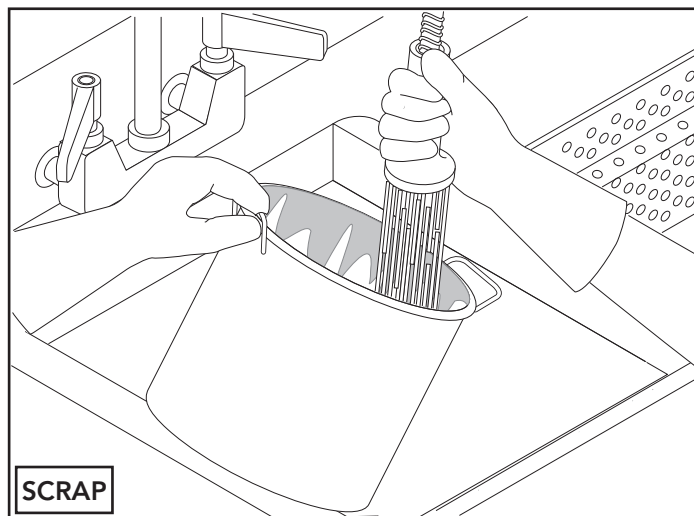

Fig. 21 -
Flush wares in the scrap sink.

3. The utensil basket hangs from the side of the wash tank to hold spoons, spatulas and other dull-edged kitchen tools.



NEVER PLACE KNIVES OR OTHER SHARP OBJECTS IN THE SINK OR THE UTENSIL BASKET.



Fig. 22 -
Utensil basket.

4. Load items in the wash tank making sure pots, and bowls lay on their sides and do not nest inside one another. Items must be fully submerged to wash properly.

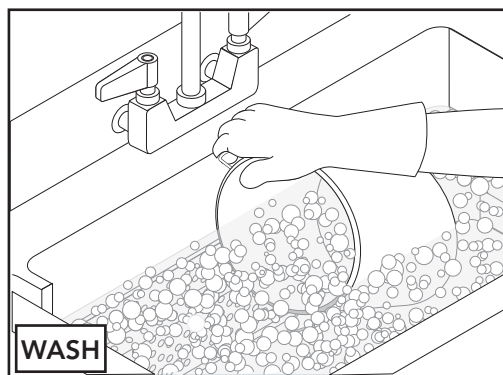

Fig. 23-
Place soiled wares in wash tank.



NOTE:

Washing is a continuous operation. Check the cleanliness of items as they wash, remove them when they are clean and replace with soiled items as the clean wares are removed.

5. Rinse wares in the rinse sink to remove loosened soils. Return to wash tank if wares require additional processing.

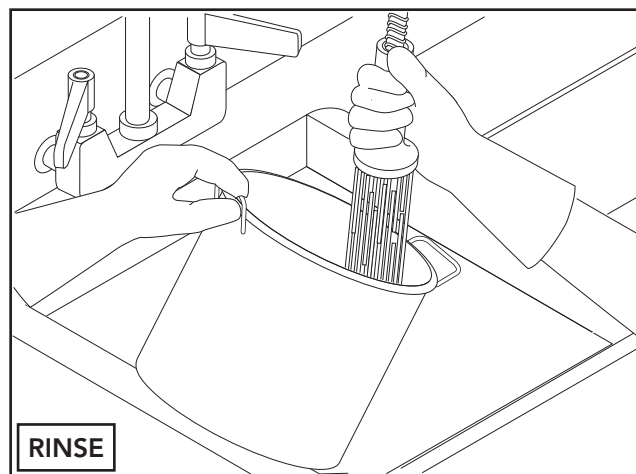

Fig. 24 -
Rinse wares in the rinse tank.

LOADING and CLEANING WARES (continued)

6. Submerge wares in the sanitizing tank according to the chemical supplier's instructions to ensure proper sanitization.

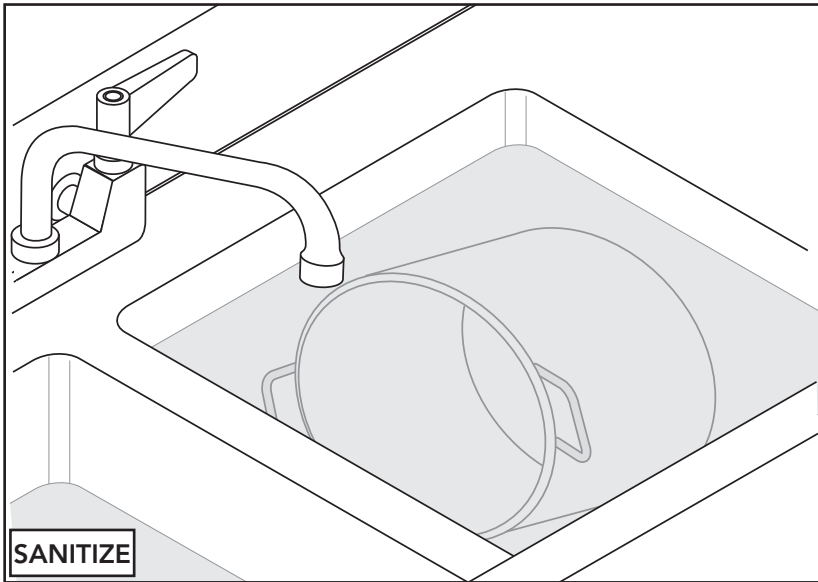

Fig. 25 -

Sanitize the wares according to the chemical supplier's instructions.

7. Remove wares from sanitizer sink to air dry on the drain board rack or on remote drying racks.



Fig. 26 -

Air dry wares on the clean drain board or remote racks.

ALARM CONDITIONS

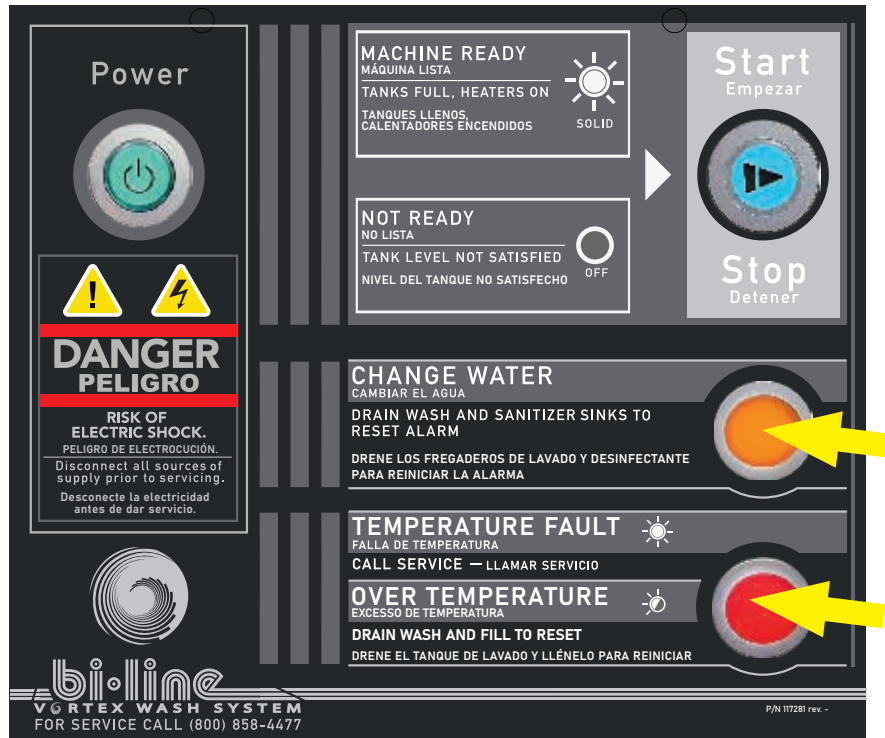

CHANGE WATER:

The machine runs automatically for a total of four hours. The amber CHANGE WATER light illuminates. Drain the machine to reset the light.

TEMPERATURE FAULT:

The TEMPERATURE FAULT RED LIGHT will illuminate and machine heater will turn off. The machine will continue to run but the heater will not come on until the fault is corrected.

Cleaning and Maintenance

CLEANING

1. Turn machine power off.
2. Open all drains.
3. Remove wares left inside machine.
4. Flush debris from inside the machine and wipe with a clean cloth.
5. Check drains for debris. Clean drain screens.
6. Flush utensil basket, and scrap screen on back wall.
7. Wipe tank sensors with a clean soft cloth.
8. Clean the exterior of the machine with a mild detergent and soft cloth.
DO NOT HOSE WITH WATER.
9. Inspect sheet pan racks for damage and replace if needed.

Maintenance

Daily

1. Check for loose or broken parts, especially the drain screens inside the tanks.
2. Check for leaks at the faucets and sprayers.
3. Clean the machine at the end of the day.

Annually

Contact the authorized service agent to perform a preventive maintenance inspection.

Lubrication

There are no lubrication requirements.

Service Replacement Parts

<u>Illustration</u>	<u>Page</u>
Control Cabinet with Heat	16
Control Cabinet without Heat.....	20
Operation Labels.....	24
Faucets, Drains, Screens, Baskets, and Tray Racks	26
Sensor, Control Cabinet Mounting, Transformer	28
Pump Install No Heat	30
Pump Install with Tank Heater Assembly	32
Pump and Motor Assembly.....	34

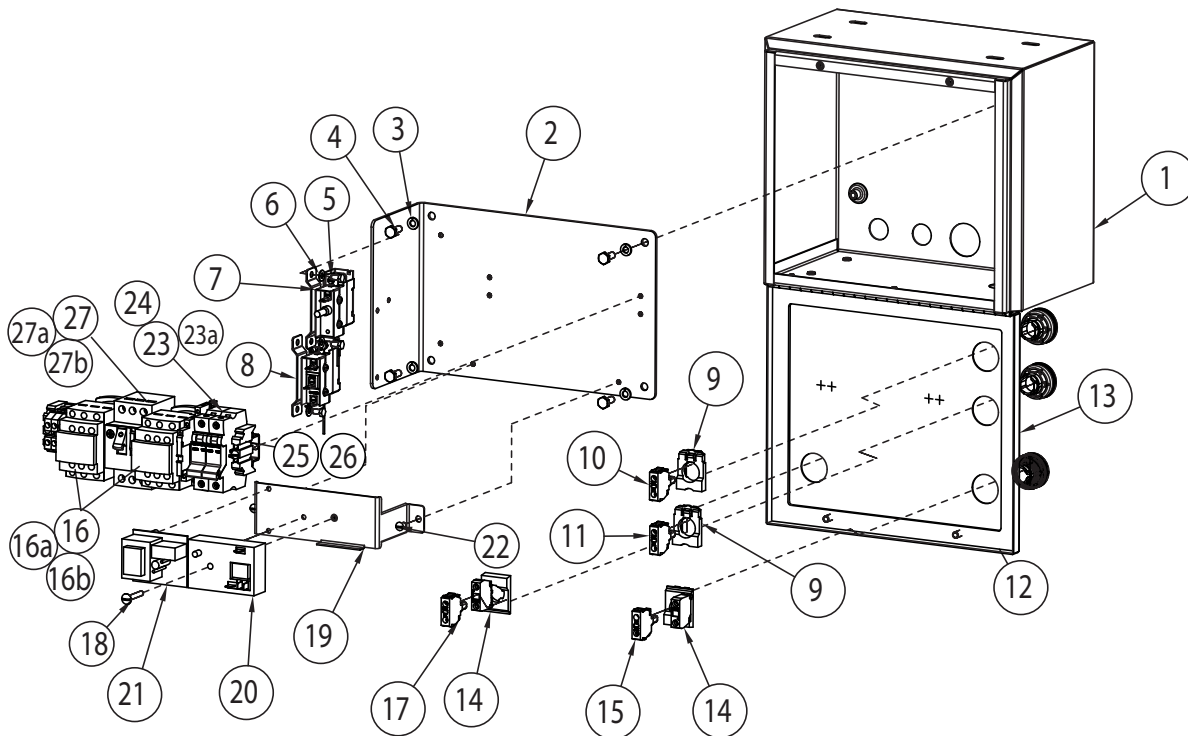

Control Cabinet with Heat (continued on page 19)

Item No.	Part No.	Description	Qty.
1	340186	CONTROL CABINET WELDMENT	1
2	340113	INNER PANEL, CONTROL CABINET	1
3	106482	WASHER, LOCK 1/4" SPLIT SST	4
4	100735	BOLT, HEX HEAD, 1/4-20 X 5/8" SST	4
5	107136	BOLT, HEX HEAD, 10-32 X 3/8" SST	4
6	107033	WASHER, FLAT .209 X .438 X .03 SST	4
7	110561	THERMOSTAT, FIXED HI-LIMIT 240°F 1/2" NPT	1
8	109069	THERMOSTAT W/CAPILLARY, 110-195°F	1
9	117346	CONTACT BLOCK, BASE ZB5AZ009	2
10	117349	LED LIGHT MODULE, RED 230V ZBVM4	1
11	117348	LED LIGHT MODULE, ORANGE 230V ZBVM5	1
12	117314	GASKET, CONTROL CABINET	1
13	340116	DOOR, WELDMENT, CONTROL CABINET	1
14	111617	CONTACT BLOCK, NO, W/MOUNTING BASE	2
15	117336	LED LIGHT MODULE, BLUE, ZBVM6	1
16	114342	CONTACTOR, 25A RES, 12A IND, 220V COIL LC1D12M7 208/3	2
16a	114277	CONTACTOR, 25A IND, 220V COIL LC1D25M7 208-240V/1	2
16b	114342	CONTACTOR, 25A RES, 12A IND, 220V COIL LC1D12M7 480/3	2
17	117347	LED LIGHT MODULE, GREEN, 230V, ZBVM3	1
18	100095	SCREW, ROUND, HEAD, 10-32 X 3/8" SST	4
19	340191	BRACKET, TIMER/WL CONTROL, VWS NO HMI	1
20	115395	TIMER, INFITEC, KMKR, 6-240 MINUTES, KMKR6ED6C	1
21	115396	LEVEL CONTROLLER, WARWICK, 240VAC, 16BA0-03	1
22	106396	SCREW, 10-32 X 1-1/4" TRUSS HEAD	1
23	111821	FUSE, LPCC-3, 600V, 208-240V/1, 208-240V/3	2
23a	112484	FUSE. ATDR, LPCC-1.5A 600V, 480V/3	2
24	111153	FUSE BLOCK, DIN RAIL 600V, 30A	2
25	113769-9-5	DIN RAIL, CUT TO 9.5" LONG	1
26	114519	END BLOCK, E/NS 35 N	2
27	111629	MOTOR STARTER, 6.0-10.0 AMPS, 208/60/3	1
27a	113161	MOTOR STARTER, 9.0-14.0 AMPS, 208/60/1	1
27b	111628	MOTOR STARTER, 4.0-6.3 AMPS, 480/60/3	1
NS	100007	SCREW, TRUSS HEAD, 10-32 X 3/8" SST (not shown)	3
NS	100073	SCREW, TRUSS HEAD, 1/4-20 X 1/2" SST (not shown)	2

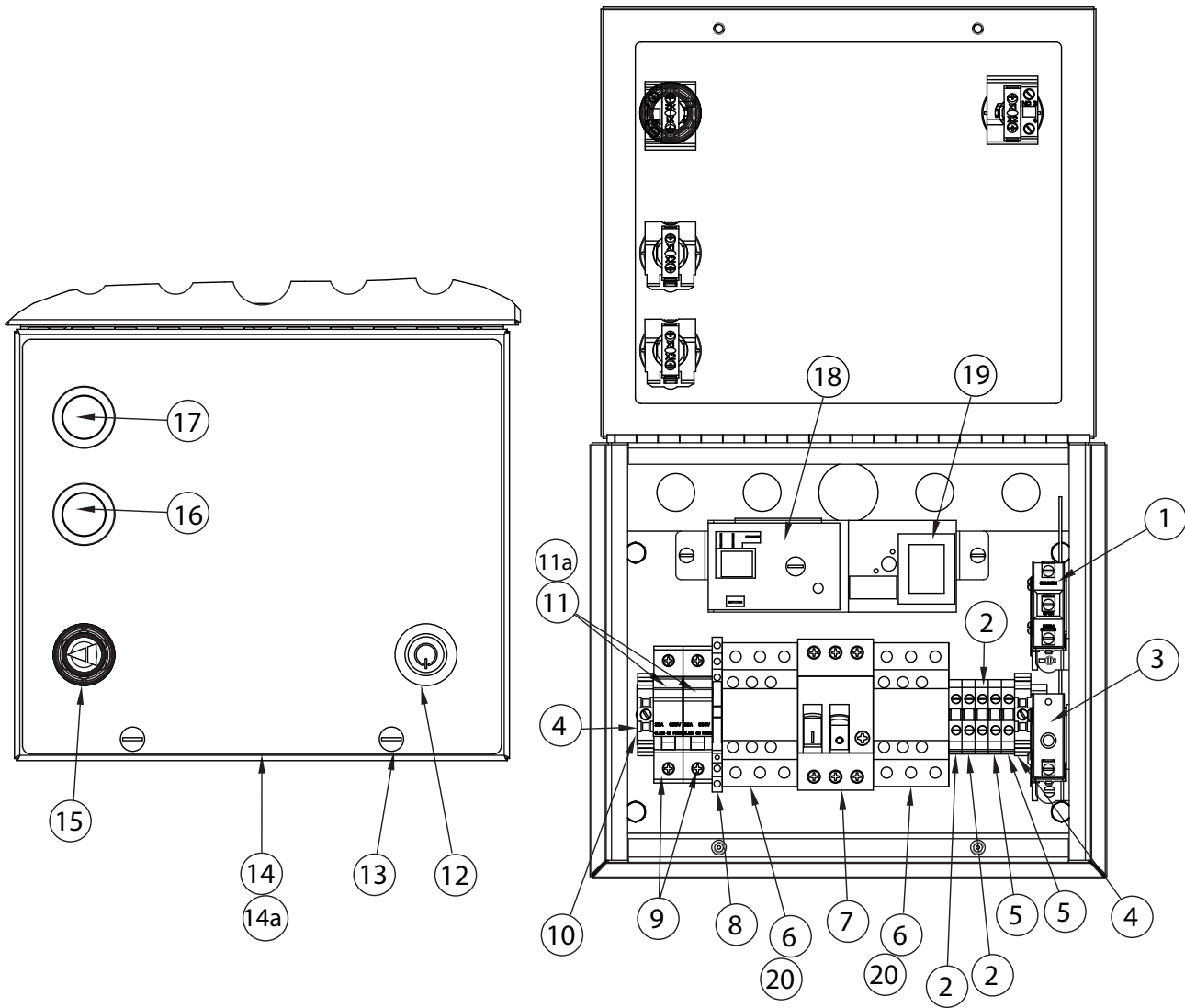

Control Cabinet with Heat, (continued from page 17)

Item No.	Part No.	Description	Qty.
1	109069	THERMOSTAT, CONTROL, WITH CAPILLARY	1
2	B501590-1	BLOCK, TERMINAL, PHOENIX UK6N	3
3	110561	FIXED, HI-LIMIT WITH CAPILLARY, 240°F, 1/2" NPT	1
4	114519	END BLOCK, E/NS 35 N	2
5	B501591-1	BLOCK, TERMINAL, PHOENIX UK6N	2
6	114342	CONTACTOR, 25A RES., 12A, 220V COIL, LC1D12M7 208-240V/3, 480V/3	2
7	111629	MOTOR STARTER, 6.0-10A, 208/240/3	1
7a	111628	MOTOR STARTER, 4.0-6.3A, 480V/3	1
7b	113161	MOTOR STARTER, 9.0-14.0A 208-240V/1	1
8	117381	RELAY, SLIM 220V COIL	1
9	111153	FUSE HOLDER ASSY.	2
10	113769-9-5	DIN RAIL, 35MM X 15 MM X 9.5" LG.	1
11	111821	FUSE, ATDR, 3A, LPCC-3, 600V, 208-240V/1, 208-240V/3	2
11a	112484	FUSE, ATDR, 1-1/2A, LPCC-1.5, 480V/3	2
12	111721	PUSH BUTTON, FLUSH GREEN, ILLUM, 30MM METALLIC	1
13	100073	SCREW, TRUSS HEAD, 1/4-20 X 1/2" SST	2
14	117281	DECAL, CONTROL CABINET, ENGLISH/SPANISH (Prior to 11/1/21 for special applications)	1
14a	117401	DECAL, CONTROL CABINET, ENG/FR/SPA (Beginning with 11/1/21 for special applications)	1
15	117272	PUSH BUTTON, FLUSH, BLUE, ILLUM. 30MM METALLIC	1
16	117275	INDICATOR, LIGHT, ORANGE 30MM, METALLIC	1
17	117274	INDICATOR, LIGHT, RED, 30MM METALLIC	1
18	115395	TIMER, INFITEC, KMKR, 6-240 MINUTES, KMKR6ED6C	1
19	115396	LEVEL CONTROLLER, WARWICK, 240VAC, 16BA0-03	1
20	114277	CONTACTOR, 25A IND., 12A, 220V COIL, LC1D25M7 208-240V/1	2
NS	100007	SCREW, TRUSS HEAD, 10-32 X 3/8" SST (not shown)	3
NS	100095	SCREW ROUND HEAD, 10-32 X 3/8" SST (not shown)	4

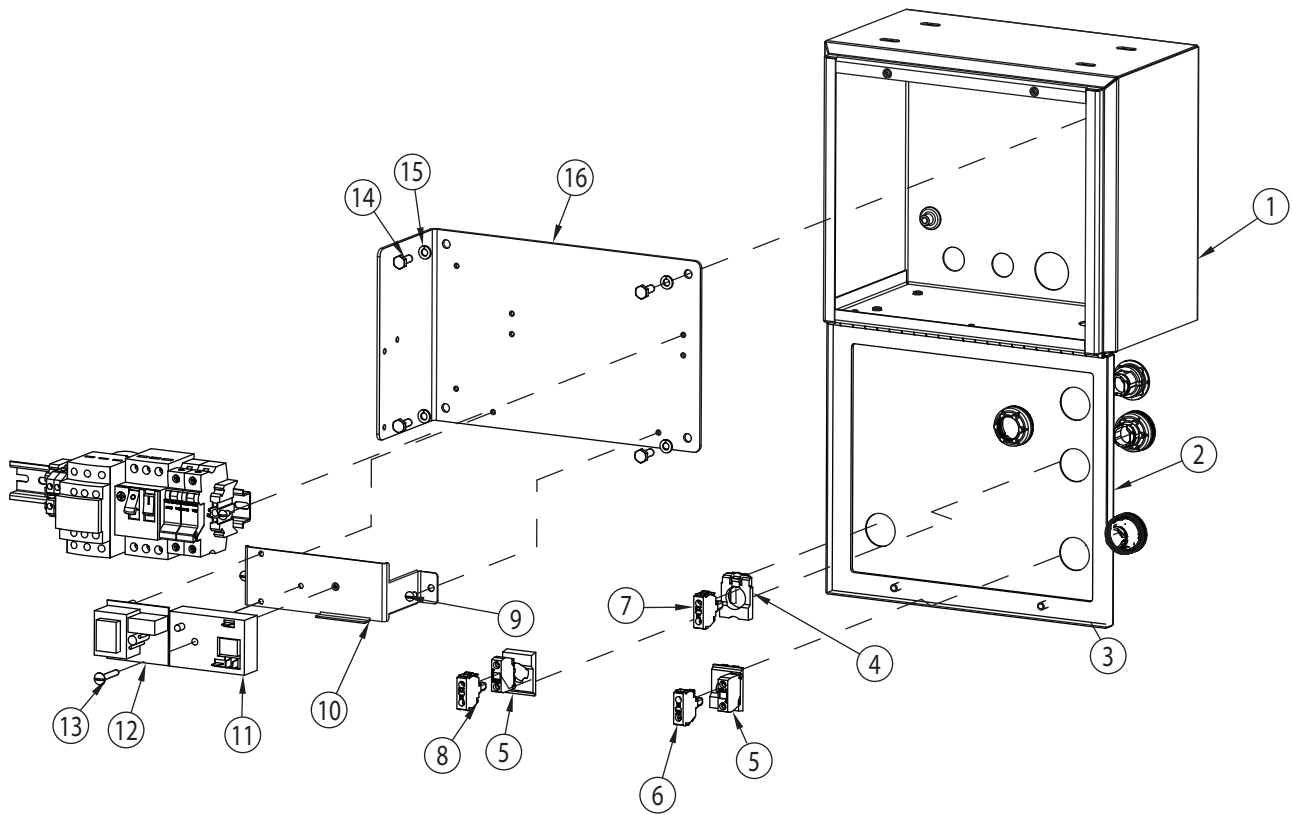

Control Cabinet without Heat, (continued on page 23)

Item No.	Part No.	Description	Qty.
1	340186	CONTROL CABINET WELDMENT	1
2	340116	DOOR WELDMENT, CONTROL CABINET	1
3	117314	GASKET, CONTROL CABINET	1
4	117346	CONTACT BLOCK, BASE ZB5AZ009	1
5	111617	CONTACT BLOCK, NO W/MOUNTING BASE	2
6	117336	LED, LIGHT MODULE, BLUE, 230V ZBVM6	1
7	117348	LED, LIGHT MODULE, ORANGE, 230V ZBVM5	1
8	117347	LED, LIGHT MODULE, GREEN, 230V, ZBVM3	1
9	100095	SCREW, ROUND HEAD, 10-32 X 3/8" SST	4
10	340191	BRACKET, TIMER/WL CONTROL, VWS NO HMI	1
11	115395	TIMER, INFITEC, KMKR, 230VAC, 6-240 MIN. KMKR6E06C	1
12	115396	LEVEL CONTROLLER, WARRICK, 240VAC, 16BA0-03	1
13	106396	SCREW, TRUSS HEAD, 10-32 X 1-1/4" SST	1
14	100735	BOLT, HEX HEAD, 1/4-20 X 5/8" SST	4
15	106482	WASHER, LOCK 1/4" SPLIT, SST	4
16	340113	INNER PANEL, CONTROL CABINET	1
NS	100073	SCREW, TRUSS HEAD, 1/4-20 X 1/2" SST (not shown)	2
NS	100007	SCREW, TRUSS HEAD, 10-32 X 3/8" SST (not shown)	3

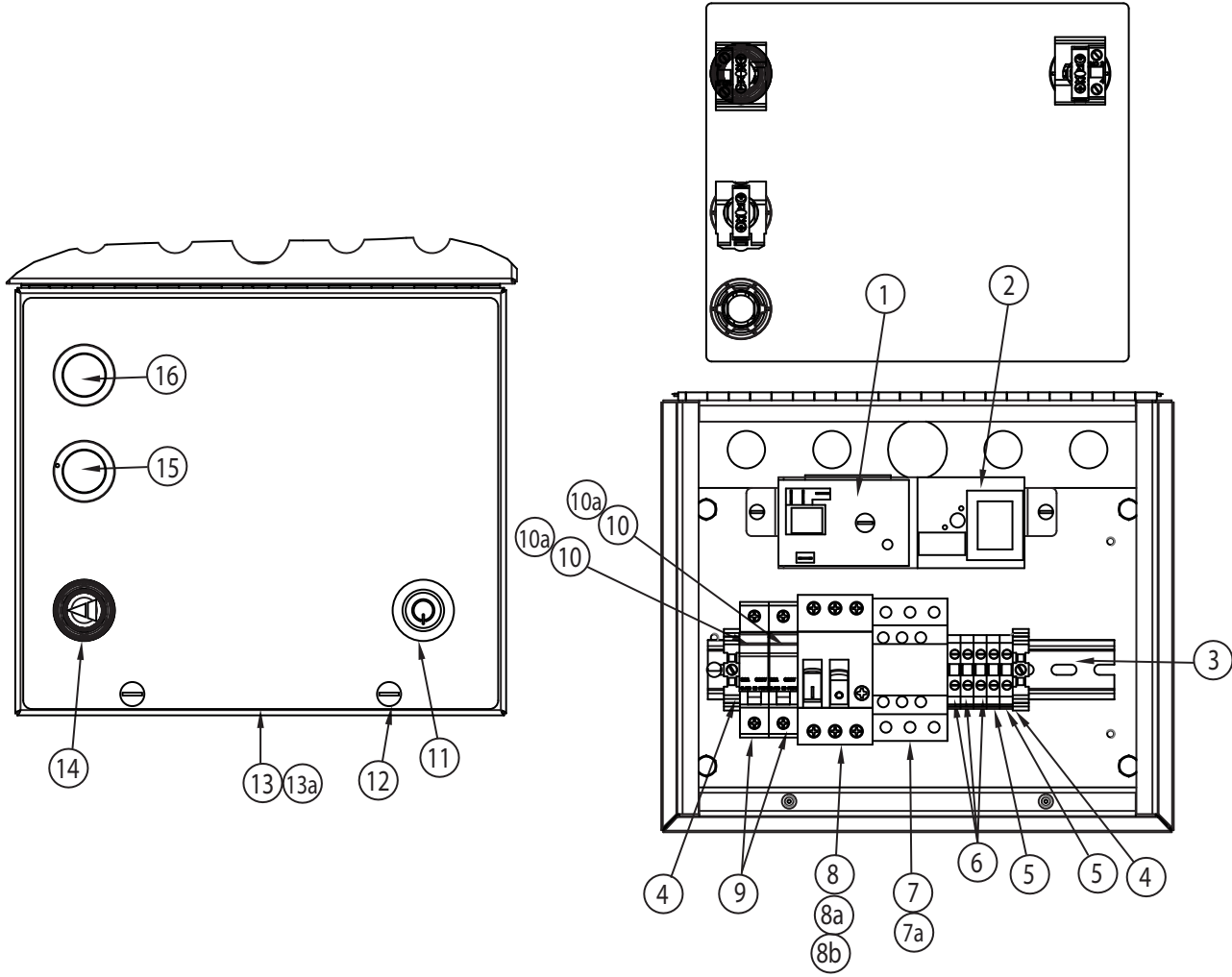

Control Cabinet without Heat, (continued from page 21)

Item No.	Part No.	Description	Qty.
1	115395	TIMER, INFITEC, 230VAC, 6-240 MIN. KMKR6E06C	1
2	115396	LEVEL CONTROLLER, WARRICK, 240VAC, 16BAO-03	1
3	113769-9-5	DIN RAIL, 35MM X 15 MM X 9.5" LG.	1
4	114519	END BLOCK, E/NS 35 N	2
5	B501591-1	BLOCK, TERMINAL, PHOENIX UK6N	2
6	B501590-1	BLOCK, TERMINAL, PHOENIX UK6N	1
7	114277	CONTACTOR, 25A IND., LC1D25M7, (208-240V/1)	1
7a	114342	CONTACTOR, 25A, RES., LC1D12M7 (208-240V/3), (480V/3)	1
8	113161	MOTOR STARTER, 9.0-14.0A, 208-240V/1	1
8a	111629	MOTOR STARTER, 4.0-6.3A, 208-240V/3	1
8b	111628	MOTOR STARTER, 6.0-10A, 480V/3	1
9	111553	FUSE HOLDER ASSEMBLY	2
10	111821	FUSE, ATDR, 3A, LPCC-3, 600V, 208-240V/1, 208-240V/3	2
10a	112484	FUSE, ATDR, 1-1/2A, LPCC-1.5, 480V/3	2
11	111721	PUSH BUTTON, FLUSH GREEN, ILLUM, 30MM METALLIC	1
12	100073	SCREW, TRUSS HEAD, 1/4-20 X 1/2" SST	2
13	117281	DECAL, CONTROL CABINET, ENGLISH/SPANISH (Prior to 11/1/21 for special applications)	1
13a	117401	DECAL, CONTROL CABINET, ENG/FR/SPA (Beginning with 11/1/21 for special applications)	1
14	117272	PUSH BUTTON, FLUSH, BLUE, ILLUM. 30MM METALLIC	1
15	117275	INDICATOR, LIGHT, ORANGE 30MM, METALLIC	1
16	117274	INDICATOR, LIGHT, RED, 30MM METALLIC	1
NS	100007	SCREW, TRUSS HEAD, 10-32 X 3/8" SST (not shown)	3
NS	100095	SCREW, ROUND HEAD,, 10-32 X 3/8" SST	4
NS	100735	BOLT, HEX HEAD, 10-32 X 1-1/4" SST	1

Operation Labels

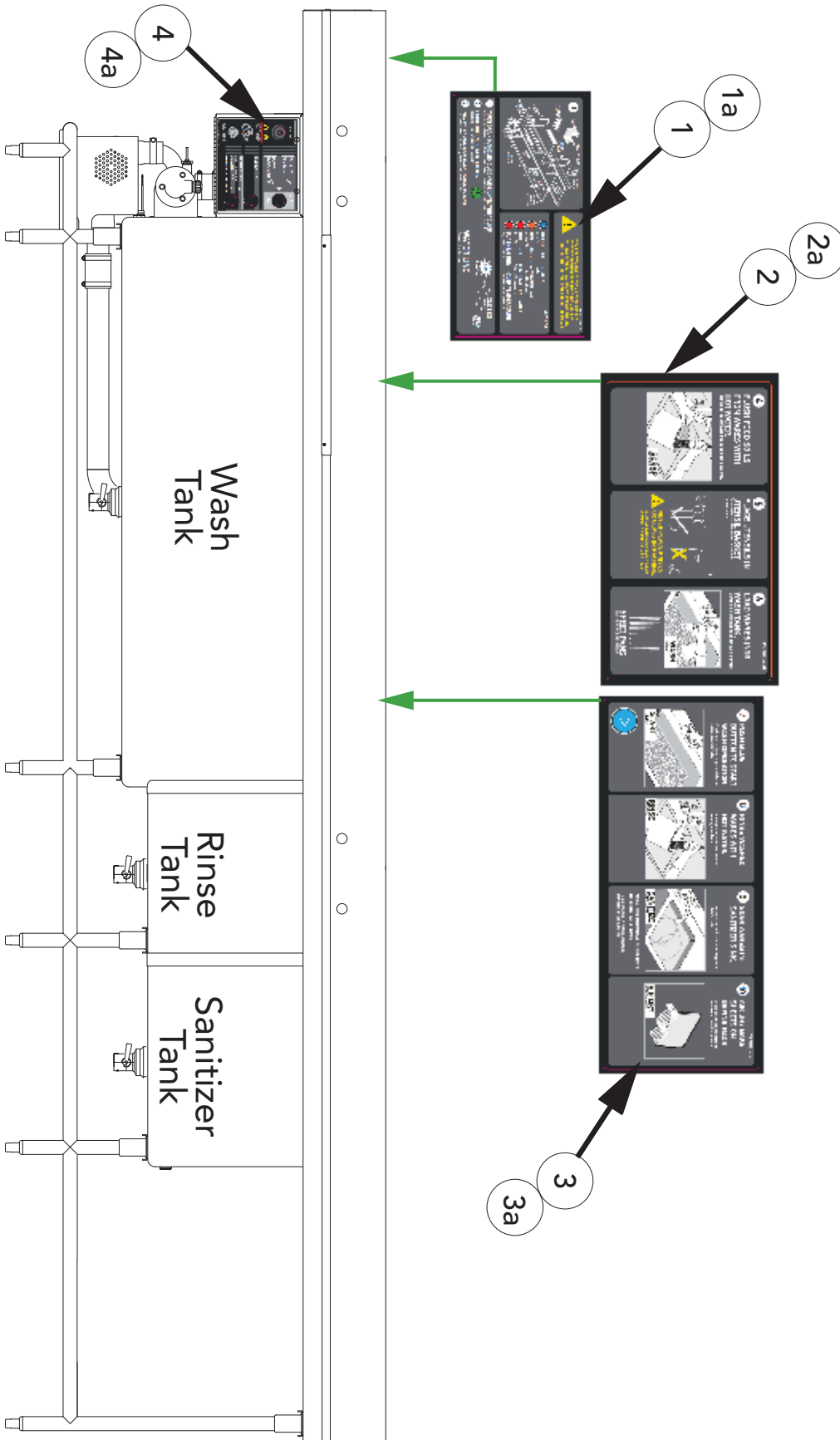

Operation Labels

Item No.	Part No.	Description	Qty.
1	117323	Label, STEPS 1, 2, 3, (English/Spanish)	1
1a	117397	Label, STEPS 1, 2, 3, (English/Canadian French/Spanish)	1
2	117324	Label, STEPS 4, 5, 6 (English/Spanish)	1
2a	117398	Label, STEPS 4, 5, 6, (English/Canadian French/Spanish)	1
3	117325	Label, STEPS 7, 8, 9, 10, (English/Canadian French/Spanish)	1
3a	117399	Label, STEPS 7, 8, 9, 10, (English/Canadian French/ Spanish)	1
4	117281	Label, CONTROL CABINET (English/Spanish)	1
4a	117401	Label, CONTROL CABINET (English/Canadian French/Spanish)	1

Faucets, Drains, Screens, Baskets, and Sheet Pan Racks

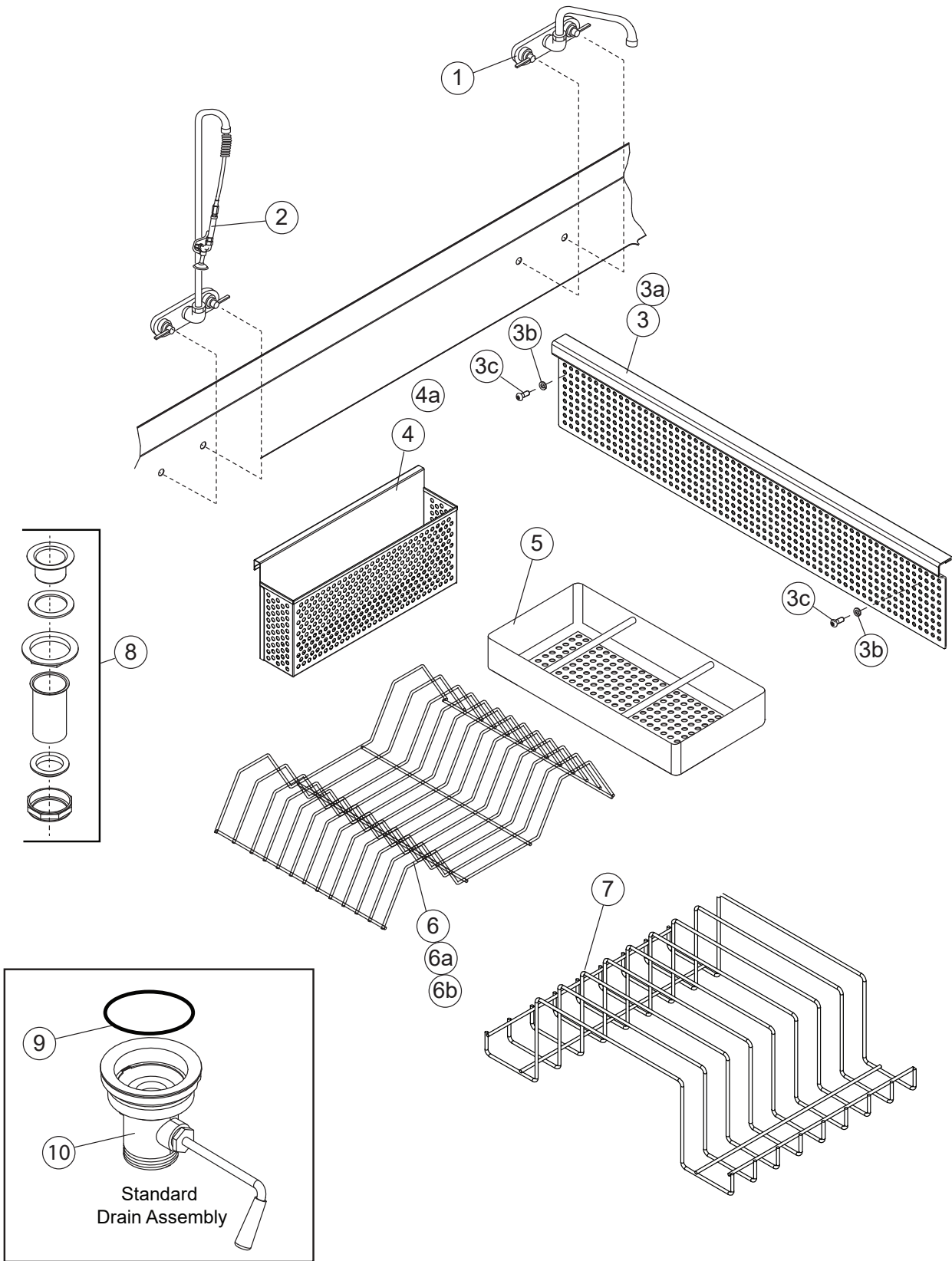

Faucets, Drains, Screens, Baskets, and Sheet Pan Racks

Item No.	Part No.	Description	Qty.
1	117316	FAUCET/PRE-RINSE COMBO, 3/4"	1
2	117317	SPRAYER/PRE-RINSE 1/2"	1
3	340133	STANDARD, INTAKE FILTER SCREEN,	1
3a	340489	TAMPER-PROOF, INTAKE FILTER SCREEN (special order)	1
3b	106482	WASHER, LOCK 1/4" SPLIT, SST (special order)	2
3c	111529	SCREW, BUTTON HEAD, 1/4-20 X 3/4" (special order)	2
4	340235	UTENSIL BASKET, 30"	A/R
4a	340214	UTENSIL BASKET, 18"	A/R
5	117135	SCRAPPER TANK BASKET, 11.625" X 20.625"	1
6	117332	DRYING RACK, 8 SLOT	A/R
6a	117333	DRYING RACK, 12 SLOT	A/R
6b	117334	DRYING RACK, 16 SLOT	A/R
7	340900	8 PIECE SHEET PAN WELDMENT	1
8	0503928	SCRAPPER DRAIN PIPE, 1-1/2" W/NUTS	1
9	117560	O-RING, LEVER-TYPE DRAIN PLUNGER	3
10	110529	DRAIN ASSEMBLY, TWIST LEVER TYPE, 2", (Includes Item 9)	3

Sensor, Control Cabinet Mounting, Transformer

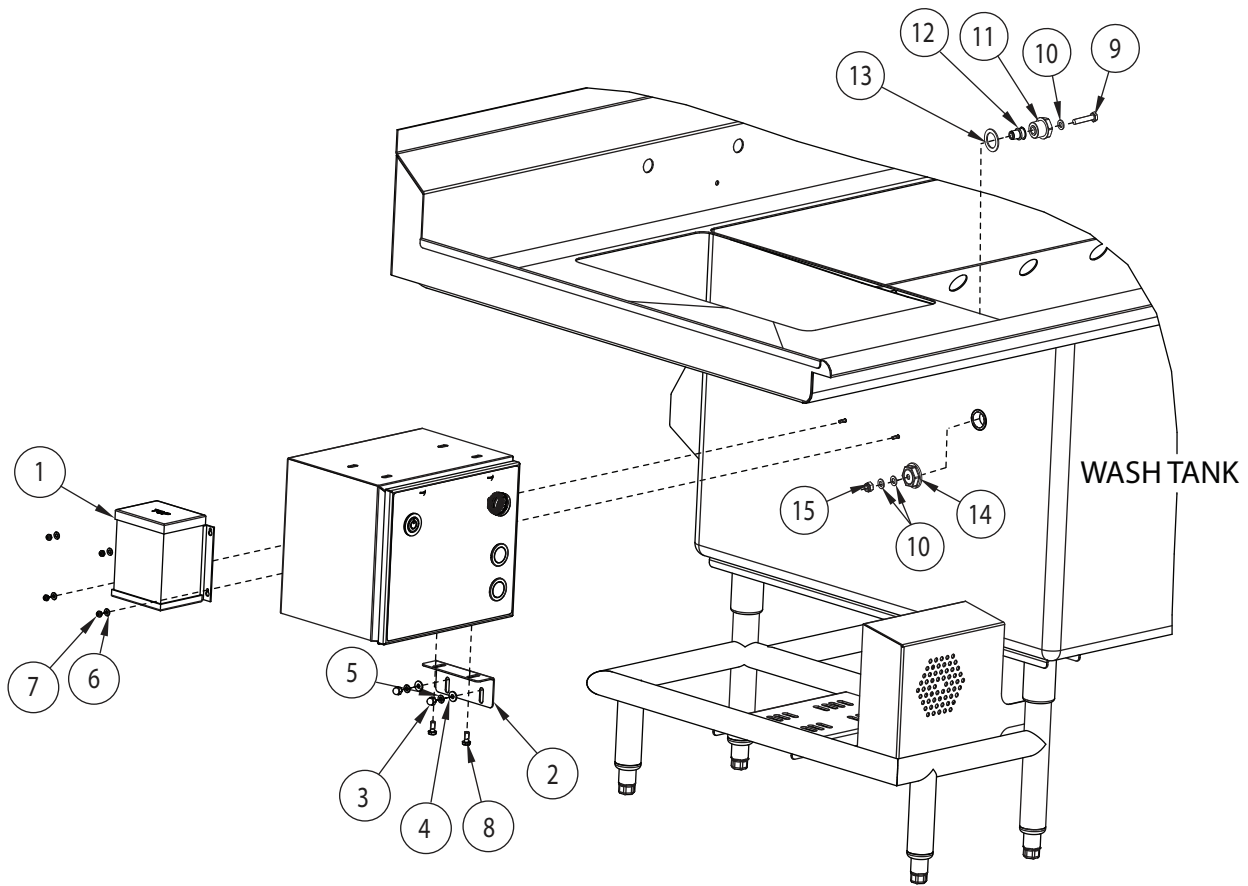

Sensor, Control Cabinet Mounting, Transformer

Item No.	Part No.	Description	Qty.
1	100280	TRANSFORMER,250VA,240/480V: 120/240V	1
2	340198	BRACKET, CONTROL CABINET SUPPORT	1
3	106014	HEX, ACORN PLAIN NUT, 1/4-20 SST	2
4	106026	WASHER, FLAT, 1/4" X 5/8" X 1/16" SST	2
5	106482	WASHER, LOCK 1/2" SPLIT, SST	2
6	107033	WASHER, FLAT, .208" X .438" X .03" SST	4
7	108954	HEX GRIP NUT, 6-32 SST W/NYLON	4
8	113272	SCREW, HEX, WASHER HEAD, 1/4-20 X 5/8" SST	2
9	0501421	BOLT, HEX HEAD, 1/4-20 X 1-1/4" FULL THREAD	1
10	102383	WASHER, FLAT, 17/64 X 1/2" X .32" SST	3
11	108418	PLUG, 1/2" PLASTIC	1
12	112436	RIVNUT, 1/4-20 MONEL	1
13	109034	GASKET, 13/16" X 1-3/16" (1/2" PLUG)	1
14	108417	LOCKNUT, 1/2" PLASTIC	1
15	107967	HEX GRIP NUT, 1/4-20 SST W/NYLON	1
---	0709773-S	PROBE SUB-ASSY., WATER LEVEL (Includes items 9-15)	A/R

Pump Install No Heat

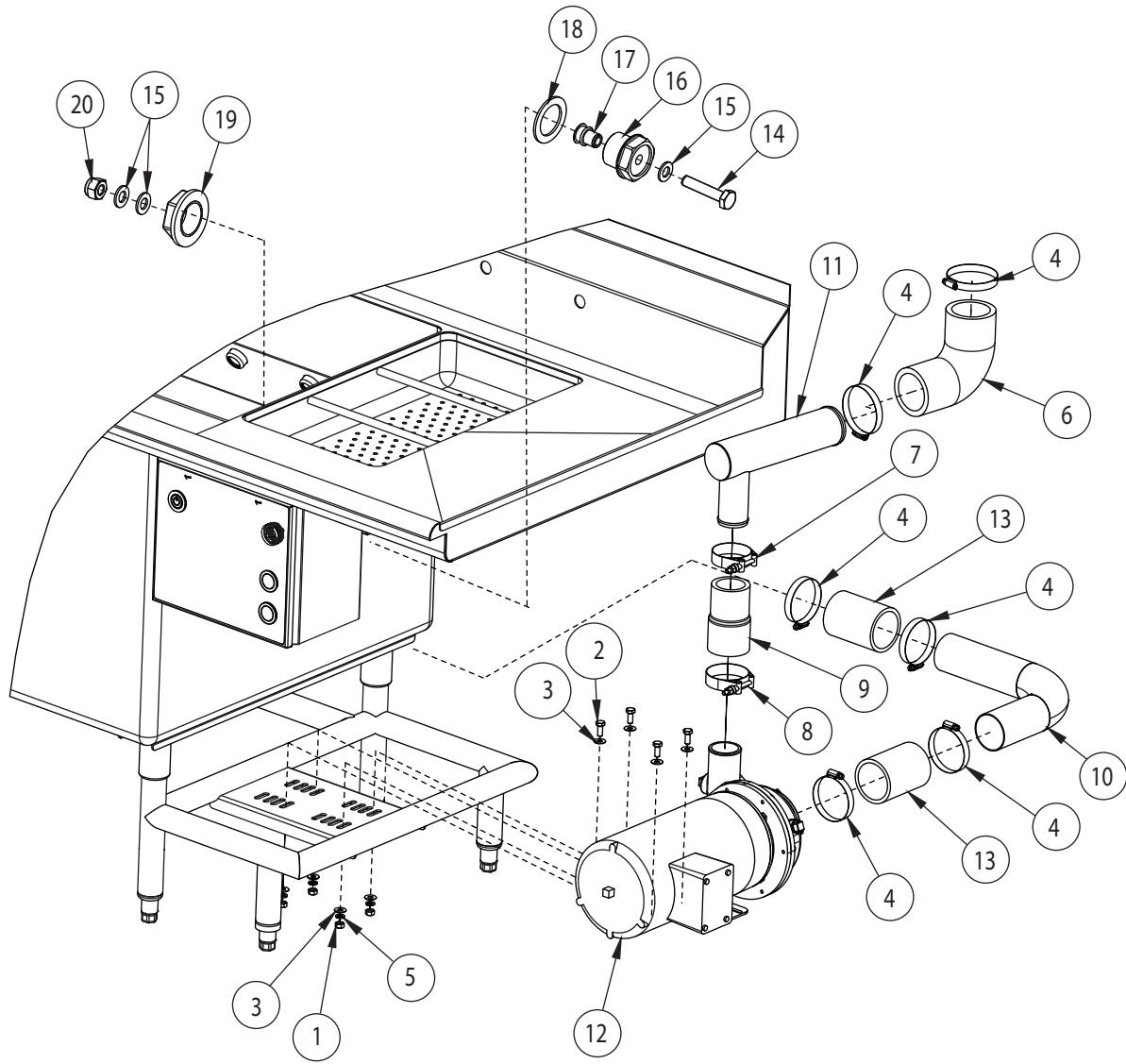

Pump Install No Heat

Item No.	Part No.	Description	Qty.
1	100154	HEX PLAIN NUT, 5/16-18 SST	4
2	100739	BOLT, HEX HEAD, 5/16-18 X 3/4" SST	4
3	102376	WASHER, FLAT 5/16" X 3/4" X .05" SST	8
4	104203	CLAMP, HOSE M52 SST GEAR-TYPE	6
5	106013	WASHER, LOCK 5/16" SPLIT, SST	4
6	110372	HOSE, PUMP SUCTION	1
7	110858	HOSE, CLAMP HIGH PRESSURE, 0256	1
8	111964	HOSE, CLAMP HIGH PRESSURE, 0275	1
9	113984	HOSE, DISCHARGE MOLDED	1
10	340121	SUCTION ELBOW WELDMENT, COMMON PUMP SIDE	1
11	340180	ELBOW, PUMP DISCHARGE, VWS	1
12	405923	3HP, PUMP/MOTOR ASSY/3HP/3PH MV	1
13	0509767	HOSE, 2.5" ID X 4" LG. EPDM	2
14	0501421	BOLT, HEX HEAD, 1/4-20 X 1-1/4" FULL THREAD	1
15	102383	WASHER, FLAT, 17/64 X 1/2" X .32" SST	3
16	108418	PLUG, 1/2" PLASTIC	1
17	112436	RIVNUT, 1/4-20 MONEL	1
18	109034	GASKET, 13/16" X 1-3/16" (1/2" PLUG)	1
19	108417	LOCKNUT, 1/2" PLASTIC	1
20	107967	HEX GRIP NUT, 1/4-20 SST W/NYLON	1
---	0709773-S	PROBE SUB-ASSY., WATER LEVEL (Includes items 14-20)	A/R

Pump Install and Tank Heater Assembly

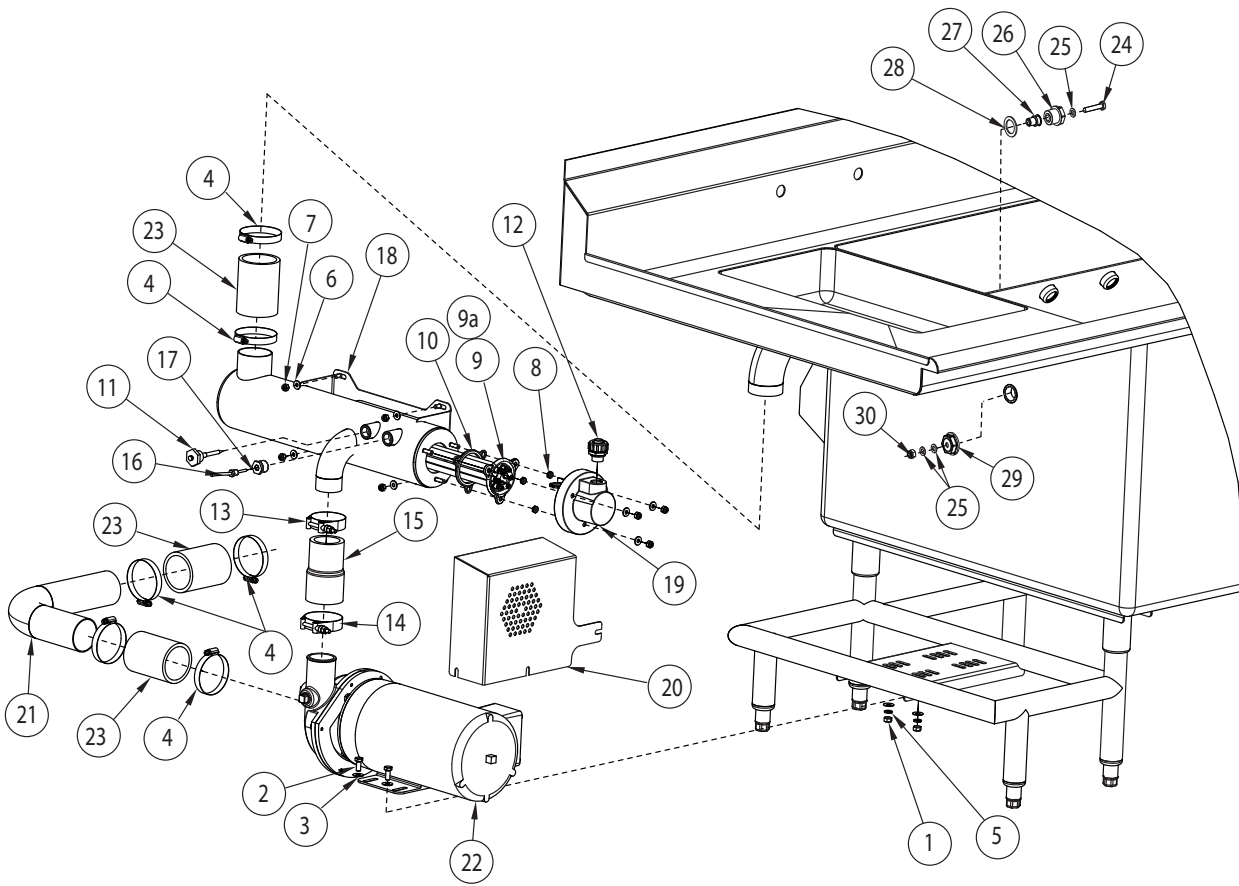

Pump Install and Tank Heater Assembly

Item No.	Part No.	Description	Qty.
1	100154	HEX PLAIN NUT, 5/16-18 SST	4
2	100739	BOLT, HEX HEAD, 5/16-18 X 3/4" SST	4
3	102376	WASHER, FLAT, 5/16 X 3/4" X .05 SST	8
4	104203	CLAMP, HOSE, M52, SST GEAR TYPE	6
5	106013	WASHER, LOCK, 5/16 SPLIT SST	4
6	106026	WASHER, FLAT, 1/4" X 5/8" X 1/16" SST	7
7	107967	HEX GRIP NUT, 1/4-20 SST W/NYLON	7
8	108521	HEX PLAIN JAM NUT, 1/4-20 SST	3
9	111237	HEATER, 5KW, 480V/60/3PH BOOSTER	1
9a	111235	HEATER, 5KW, 208/240/3 BOOSTER	1
10	109985	SEAL, BOOSTER, HEATER	1
11	110561	THERMOSTAT, FIXED HIGH LIMIT, 240°F, 1/2"NPT	1
12	110836	FITTING, STRAIGHT, 1/2" SEALTITE	1
13	110858	HOSE CLAMP, T-BOLT, 2.37"-2.68' SST	1
14	111964	HOSE CLAMP, T-BOLT, 2.56"-2.87' SST	1
15	113984	HOSE, PUMP DISCHARGE, MOLDED	1
16	114435	THERMISTOR, 10KΩ, 36" LEAD	1
17	114717	BUSHING, REDUCING, 1/2" NPT X 1/8" NPT, SST	1
18	340101	HEATER MANIFOLD, WELDMENT, LR	1
19	340118	HEATER MANIFOLD COVER	1
20	340119	GUARD, PUMP MOTOR, LR	1
21	340121	SUCTION, ELBOW WELDMENT, COMMON, PUMP SIDE	1
22	405923	3HP, PUMP/MOTOR ASSY/3HP/3PH MV3PH MV	1
23	0509767	HOSE, 2.5" ID X 4" LG. EPDM	1
24	0501421	BOLT, HEX HEAD, 1/4-20 X 1-1/4" FULL THREAD	1
25	102383	WASHER, FLAT, 17/64 X 1/2" X .32" SST	3
26	108418	PLUG, 1/2" PLASTIC	1
27	112436	RIVNUT, 1/4-20 MONEL	1
28	109034	GASKET, 13/16" X 1-3/16" (1/2" PLUG)	1
29	108417	LOCKNUT, 1/2" PLASTIC	1
30	107967	HEX GRIP NUT, 1/4-20 SST W/NYLON	1
---	0709773-S	PROBE SUB-ASSY., WATER LEVEL (Includes items 24-30)	A/R

Pump and Motor Assembly

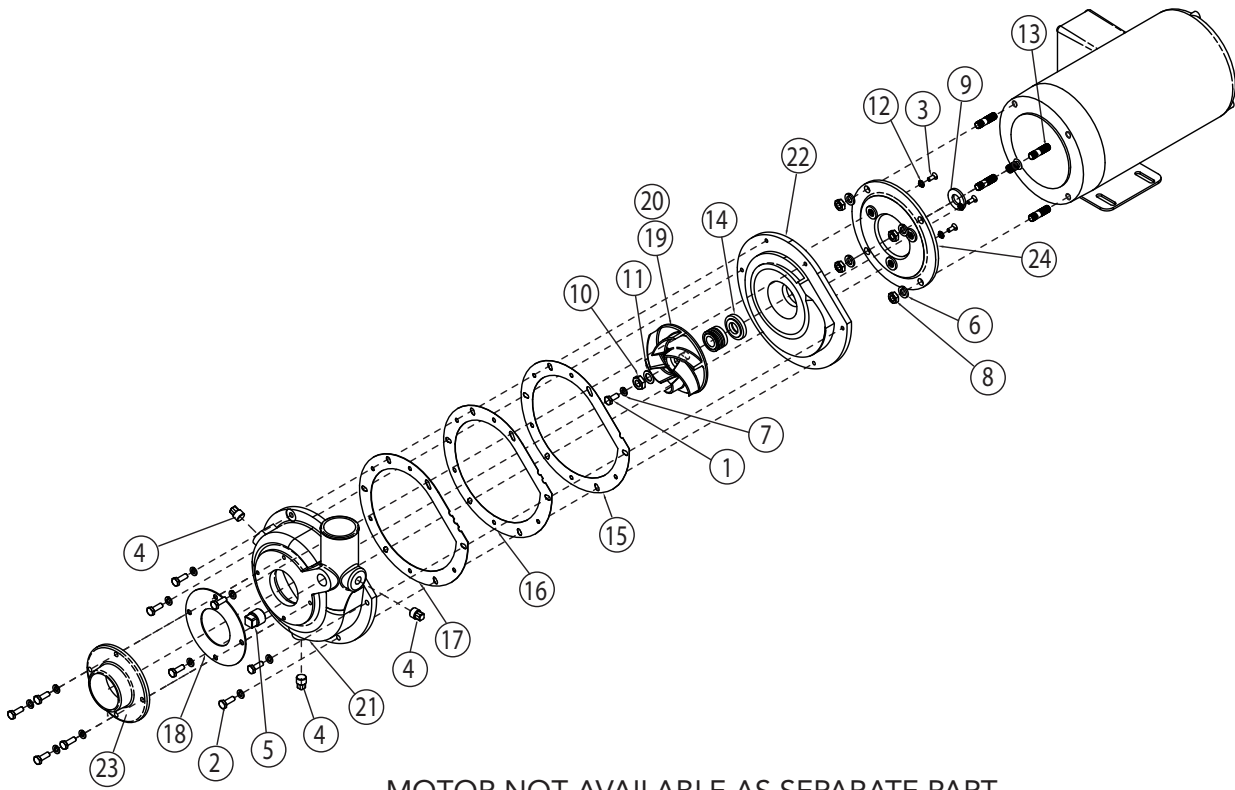

MOTOR NOT AVAILABLE AS SEPARATE PART

Pump and Motor Assembly

Item No.	Part No.	Description	Qty.
1	100735	BOLT, HEX HEAD, 1/4-20 X 5/8" SST	1
2	100736	BOLT, HEX HEAD, 1/4-20 X 3/4" SST	10
3	100754	SCREW, FLAT HEAD, 10-32 X 1/2" SST	3
4	102500	PLUG, 1/4" NPT SQ. HEAD BRASS	3
5	102504	PLUG, 1/2" NPT, SQ. HEAD BRASS	1
6	106407	WASHER, LOCK, 3/8" SPLIT, SST	4
7	106482	WASHER, LOCK, 1/4" SPLIT, SST	11
8	107690	HEX PLAIN JAM NUT, 3/8-16 SST	4
9	109654	SLINGER, PUMP	1
10	110247	HEX PLAIN JAM NUT, 7/16-202 SST	1
11	110248	WASHER, FLAT, .440" X .75" X .043" SST	1
12	110270	WASHER, C-SUNK, EXTERNAL TOOTH SST	3
13	110734	STUD, 3/8-16 X 1-3/8" LG. SST, PUMP	4
14	111111	SEAL ASSY., PUMP	1
15	111941	GASKET, PUMP VOLUTE, .0085 THICK	A/R
16	111942	GASKET, PUMP VOLUTE, .015 THICK	A/R
17	111943	GASKET, PUMP VOLUTE, .032 THICK	A/R
18	112338	GASKET, PUMP SUCTION FLANGE	1
19	113118	IMPELLER, 1HP SST, MACHINED, 1PH MOTOR	1
20	113120	IMPELLER, 3HP SST, MACHINED, 3PH MOTOR	1
21	113634	VOLUTE, JET PUMP, SST	1
22	113635	FLANGE, JET PUMP, SST	1
23	113636	SUCTION FLANGE	1
24	204460	BACKING PLATE, NG JET PUMP	1
---	405923	3HP, PUMP/MOTOR ASSY/3HP/3PH MV	
---	405923-90	3HP PUMP/MOTOR ASSY/3HP/3PH MV 90° DISCHARGE	
---	402923-180	3HP PUMP/MOTOR ASSY/3HP/60/3 180° DISCHARGE	
---	421178	2HP PUMP/MOTOR ASSY/208-240V/60/1	
---	421178-90	2HP PUMP/MOTOR ASSY/208-240V/60/1 90° DISCHARGE	
---	421178-180	2HP PUMP/MOTOR ASSY/208-240/60/1 180° DISCHARGE	

