

# Champion

The Dishwashing Machine Specialists

## Technical Manual

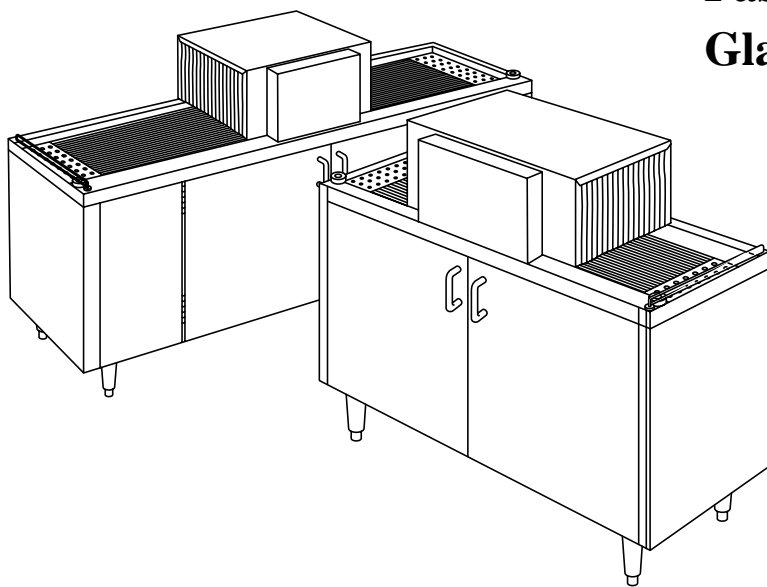

Pass-Through  
Glasswasher

Model  
CG4  
CG6

Machine Serial No.

June, 2001

Manual P/N 111557 REV. E

P.O. Box 4149  
Winston-Salem, North Carolina 27115-4149

Champion Industries, Inc.  
[www.championindustries.com](http://www.championindustries.com)

Complete the information below so it will be available for quick reference.

Model Number \_\_\_\_\_ Serial Number \_\_\_\_\_

Voltage and Phase \_\_\_\_\_

Champion Parts Distributor \_\_\_\_\_ Phone \_\_\_\_\_

Champion Service Agency \_\_\_\_\_ Phone \_\_\_\_\_

Champion Industries Service: 1-800-858-4477 Champion Service Fax: 1-336-661-1660

We strongly recommend that you Fax your orders.

**NOTE:** When calling to order parts, be sure to have the model number, serial number, voltage, and phase of your machine.

## Revision History

<b>Revision Date</b>	<b>Revised Pages</b>	<b>Serial Number Effectivity</b>	<b>Comments</b>
02/18/91	All	5181	Issued manual and service parts list, Revision A
10/12/94	4	6106	Tank switch shuts down machine, revised the schematic
05/10/95	4	6216	Changed to new style chemical injection board, revised the schematic
06/07/95	—	6226	Changed to narrow control box, eliminated float rod bearing
02/02/97	All	—	Reissue of manual and service parts lists, Revision B
02/28/00	43	—	Revised wash down Hose Assy. Parts List
06/18/00	38-39	G2182	Revised vacuum breaker part nos.
06/18/01	43	—	Added panels to optional accessories



## CONTENTS

	Page
WARRANTY .....	4
INTRODUCTION.....	5
INSTALLATION.....	6
Unpacking .....	6
Measurements .....	7
Utility Locations .....	7
Electrical Connections .....	8
Plumbing Connections.....	8
Water Connections.....	8
Drain Connections .....	8
OPERATION.....	9
General .....	9
To Fill The Wash Tank .....	9
Operating Instructions .....	9
Approximate Chemical Settings.....	10
Plumbing Diagram.....	12
MAINTENANCE.....	13
Daily Cleaning Instructions .....	13
Weekly Cleaning Instructions.....	13
TROUBLESHOOTING .....	14
REPLACEMENT PARTS.....	17
ELECTRICAL SCHEMATICS .....	44

## LIST OF FIGURES

	Page
Figure 1 — Unpacking Parts .....	6
Figure 2 — Machine Measurements .....	7
Figure 3 — Wash Tank.....	9
Figure 4 — Plumbing Diagram .....	12
Figure 5 — Main Frame Assembly.....	18
Figure 6 — Spray Assembly .....	20
Figure 7 — Main Tank Assembly .....	22
Figure 8 — Lift Bracket and Drive Assembly .....	24
Figure 9 — Hood Assembly .....	26
Figure 10 — Control Box .....	28
Figure 11 — Control Box Cover/Chemical Injector Board.....	30
Figure 12 — Detergent Tank.....	32
Figure 13 — Inlet Plumbing.....	34
Figure 14 — Sanitizer Plumbing.....	36
Figure 15 — Vacuum Breaker Plumbing .....	38
Figure 16 — Wash Pump Assembly .....	40
Figure 17 — Cleaning Accessories .....	42
Figure 18 — Optional Accessories .....	43
Figure 19 — Electrical Diagram (S/N 5181 through 6105).....	44
Figure 20 — Electrical Diagram (S/N 6106 through 6215).....	45
Figure 21 — Electrical Diagram (beginning with S/N 6216).....	46

## LIMITED WARRANTY

Champion Industries Inc. (herein referred to as Champion), P.O. Box 4149, Winston-Salem, North Carolina 27115, and P.O. Box 301, 2674 N. Service Road, Jordan Station, Canada L0R 1S0, warrants machines, and parts, as set out below.

**Warranty of Machines:** Champion warrants all new machines of its manufacture bearing the name "Champion" and installed within the United States and Canada to be free from defects in material and workmanship for a period of one (1) year after the date of installation or fifteen (15) months after the date of shipment by Champion, whichever occurs first. [See below for special provisions relating to glasswashers.] The warranty registration card must be returned to Champion within ten (10) days after installation. If warranty card is not returned to Champion within such period, the warranty will expire after one year from the date of shipment.

Champion will not assume any responsibility for extra costs for installation in any area where there are jurisdictional problems with local trades or unions.

If a defect in workmanship or material is found to exist within the warranty period, Champion, at its election, will either repair or replace the defective machine or accept return of the machine for full credit; provided, however, as to glasswashers, Champion's obligation with respect to labor associated with any repairs shall end (a) 120 days after shipment, or (b) 90 days after installation, whichever occurs first. In the event that Champion elects to repair, the labor and work to be performed in connection with the warranty shall be done during regular working hours by a Champion authorized service technician. Defective parts become the property of Champion. Use of replacement parts not authorized by Champion will relieve Champion of all further liability in connection with its warranty. In no event will Champion's warranty obligation exceed Champion's charge for the machine. The following are not covered by Champion's warranty:

- a. Lighting of gas pilots or burners.
- b. Cleaning of gas lines.
- c. Replacement of fuses or resetting of overload breakers.
- d. Adjustment of thermostats.
- e. Adjustment of clutches.
- f. Opening or closing of utility supply valves or switching of electrical supply current.
- g. Cleaning of valves, strainers, screens, nozzles, or spray pipes.
- h. Performance of regular maintenance and cleaning as outlined in operator's guide.
- i. Damages resulting from water conditions, accidents, alterations, improper use, abuse, tampering, improper installation, or failure to follow maintenance and operation procedures.
- j. Wear on Pulper cutter blocks, pulse vanes, and auger brush.

*Examples of the defects not covered by warranty include, but are not limited to:* (1) Damage to the exterior or interior finish as a result of the above, (2) Use with utility service other than that designated on the rating plate, (3) Improper connection to utility service, (4) Inadequate or excessive water pressure, (5) Corrosion from chemicals dispensed in excess of recommended concentrations, (6) Failure of electrical components due to connection of chemical dispensing equipment installed by others, (7) Leaks or damage resulting from such leaks caused by the installer, including those at machine table connections or by connection of chemical dispensing equipment installed by others, (8) Failure to comply with local building codes, (9) Damage caused by labor dispute.

**Warranty of Parts:** Champion warrants all new machine parts produced or authorized by Champion to be free from defects in material and workmanship for a period of 90 days from date of invoice. If any defect in material and workmanship is found to exist within the warranty period Champion will replace the defective part without charge.

**DISCLAIMER OF WARRANTIES AND LIMITATIONS OF LIABILITY. CHAMPION'S WARRANTY IS ONLY TO THE EXTENT REFLECTED ABOVE. CHAMPION MAKES NO OTHER WARRANTIES, EXPRESS OR IMPLIED, INCLUDING, BUT NOT LIMITED, TO ANY WARRANTY OF MERCHANTABILITY, OR FITNESS OF PURPOSE. CHAMPION SHALL NOT BE LIABLE FOR INCIDENTAL OR CONSEQUENTIAL DAMAGES. THE REMEDIES SET OUT ABOVE ARE THE EXCLUSIVE REMEDIES FOR ANY DEFECTS FOUND TO EXIST IN CHAMPION DISHWASHING MACHINES AND CHAMPION PARTS, AND ALL OTHER REMEDIES ARE EXCLUDED, INCLUDING ANY LIABILITY FOR INCIDENTALS OR CONSEQUENTIAL DAMAGES.**

Champion does not authorize any other person, including persons who deal in Champion dishwashing

## INTRODUCTION

Welcome to **Champion...**

and thank you for allowing us to take care of your glass washing needs.

This manual covers the Models CG4 and CG6 glasswashers.

Your machine was completely assembled, inspected, and thoroughly tested at our factory before it was shipped to your installation site.

This manual contains:

- Warranty Information
- Operation and Cleaning Instructions
- Maintenance Instructions
- Troubleshooting Guide
- Basic Service Information
- Replacement Parts Lists
- Electrical Schematics

Complete and return your warranty registration card within ten (10) days after the installation of your machine.

All information, illustrations and specifications contained in this manual are based upon the latest product information available at the time of publication. **Champion** constantly improves its products and reserves the right to make changes at any time or to change specifications or design without notice and without incurring obligation.

For your protection, factory authorized parts should always be used for repairs.

Replacement parts may be ordered directly from **Champion** authorized parts distributor or authorized service agency. When ordering parts, please supply the model number, serial number, voltage, and phase of your machine, the part number, part description and quantity.

# INSTALLATION

## Unpacking

1. Remove all packing from inside and on top of the machine.
2. Remove all packing from glass operated switch and left and right pick-up plates. Check that the left and right hand pick-up plates are positioned properly.
3. Check the position of the splash curtains.
4. Check that the conveyor is aligned with the drive sprockets and the lift bracket on the right hand side is firmly engaged over track adjusters.
5. Remove the packing from within and above the detergent tank.
6. Ensure the standpipe is in position in the detergent tank. Ensure the short standpipe is in position on the right hand side of the wash tank underneath the conveyor lift bracket.



**NOTE:**

*The wash tank standpipe is located inside the wash return screen for shipping.*

7. Ensure that the wash return screen in the detergent tank is in position.
8. Check that the lower drain screen is in position.

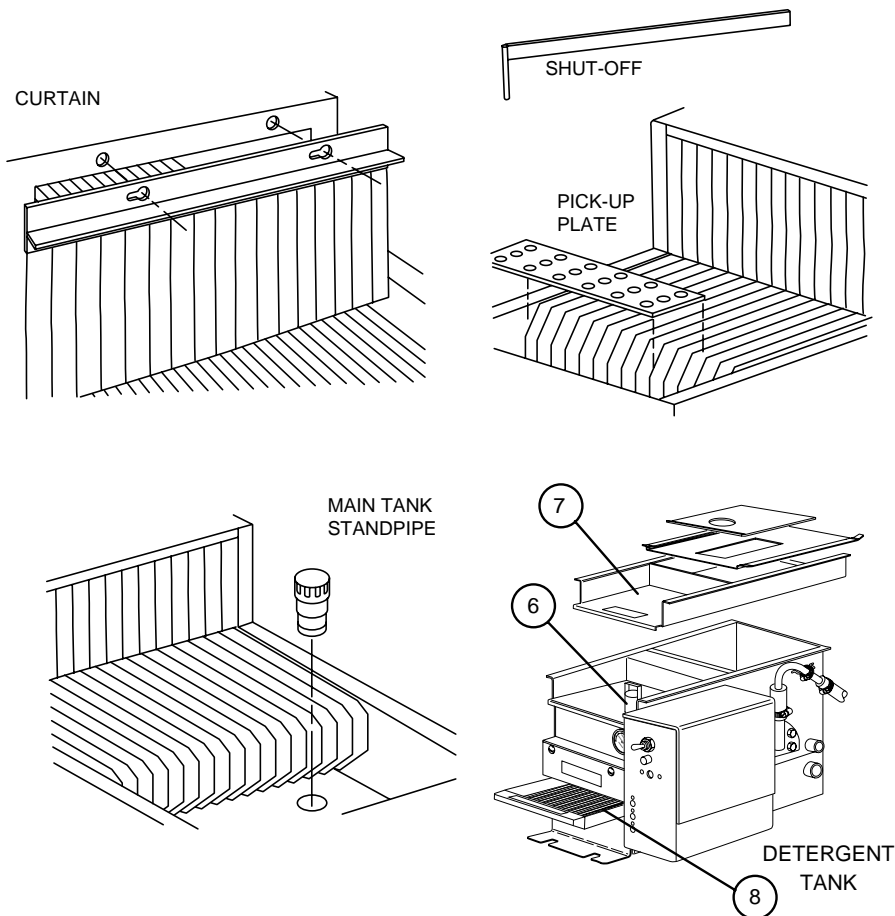

Figure 1 — Unpacking Parts



# INSTALLATION (Cont'd)

## Measurements

	Uncrated		Crated	
	SW-400	SW-600	SW-400	SW-600
Height	38-1/2" (978)	38-1/2" (978)	49" (1244)	46-1/2" (1181)
Width	48" (1219)	72" (1182)	25-1/4" (640)	27" (685)
Depth	22" (559)	22" (559)	25-1/8" (638)	27-1/2" (698)
Ship Wt.	225lb/102kg	285lb/129kg	154lb/70kg	176lb/80kg

\*adjustable foot height 1-3/4" (45)  
max. height 40-3/4" (1035)

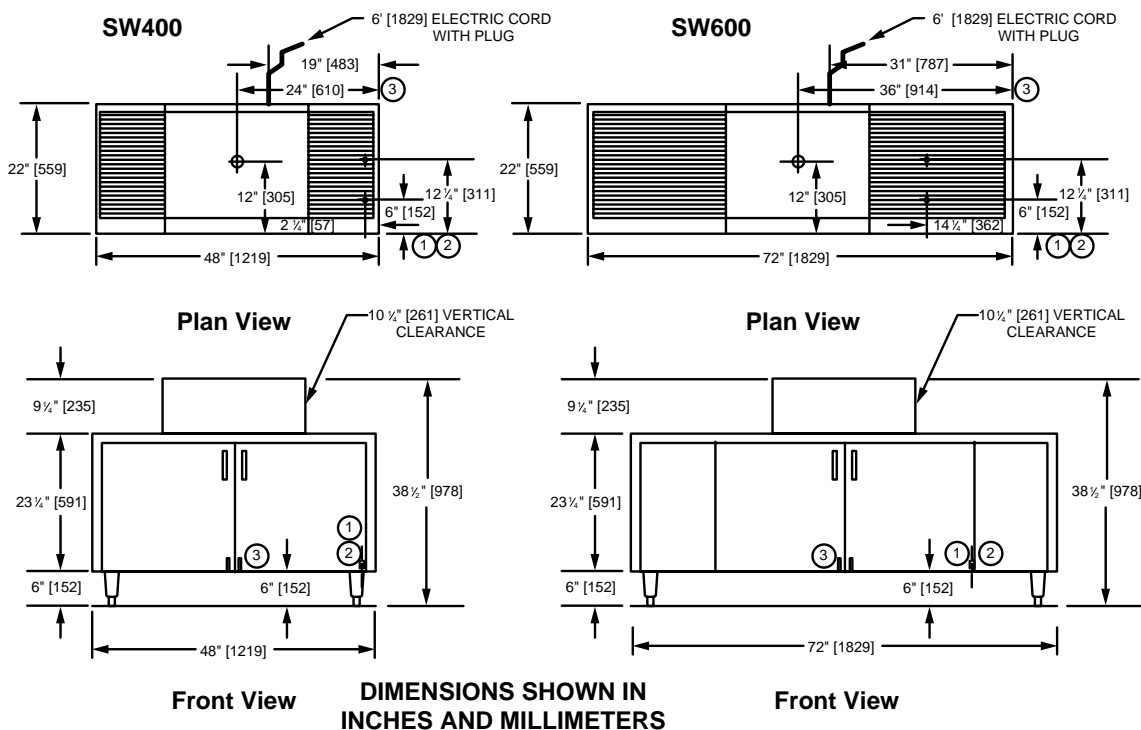

Figure 2 — Machine Measurements

## Utility Locations

1. Hot Water
2. Cold Water
3. Drain



### CAUTION:

Allow 2" (50mm) additional vertical clearance above hood to permit hood removal when installing unit under a counter top.

## INSTALLATION (Cont'd)

### Electrical Connections

1. The Glass Washer has a six foot power cord with a “U” ground tandem plug for connection to a **power** receptacle.
2. Provide a nonlocking 250 volt, 15 ampere, 2 pole, 3 wire grounding receptacle within four feet of the base of the Glass Washer(CSA TYPE 6-15R). This should be installed by a qualified electrician to meet the specifications of the local electrical code.
3. This machine operates from 208 to 240 volts.

**NOTE:**

*This machine is 50Hz and 60Hz capatable.*

### Plumbing Connections

#### Hot Water Connection

1. Connect a minimum 1/2" water line to the hot water solenoid valve. Supply temperature must be minimum 140°F/60°C, with a flow pressure between 25-95 PSI/172-656 kPa.
2. Hot water consumption is approximately 10 Imp. gph./12 U.S. gph/45 litres/h.

#### Cold Water Connection

1. Connect a minimum 1/2" water line to the cold water solenoid valve. Flow pressure must be between 25-95 PSI/172-656 kPa.
2. Open mixing valve located between hot and cold solenoid valves for areas with very cold rinse water to heat the rinse water which will prevent glasses from cracking.
3. Cold water consumption is approximately 2.4 Imp. gpm/2.8 U.S. gpm/10.6 litres/min.

**NOTE:**

*Install check valves on the hot and cold water lines as close as possible to the water inlet.*

#### Drain Connection

1. This machine is gravity drain. Connect a 1-1/2" drain line where indicated.
2. PVC pipe is generally recommended as copper is prone to attack by the sanitizing chemicals.

**WARNING:**

*Plumbing and electrical connections should be made by a qualified workman who will observe all the applicable plumbing, sanitary and safety codes. Before all utilities are installed, ensure that all the bullet feet are in contact with the floor and at the desired level.*

## OPERATION

### General

1. The wash tank is equipped with a float assembly that operates a single cam-operated switch.
2. The water temperature is controlled by a heater and a thermostat. The thermostat should be between 140°F/60°C and 160°F/ 71°C.

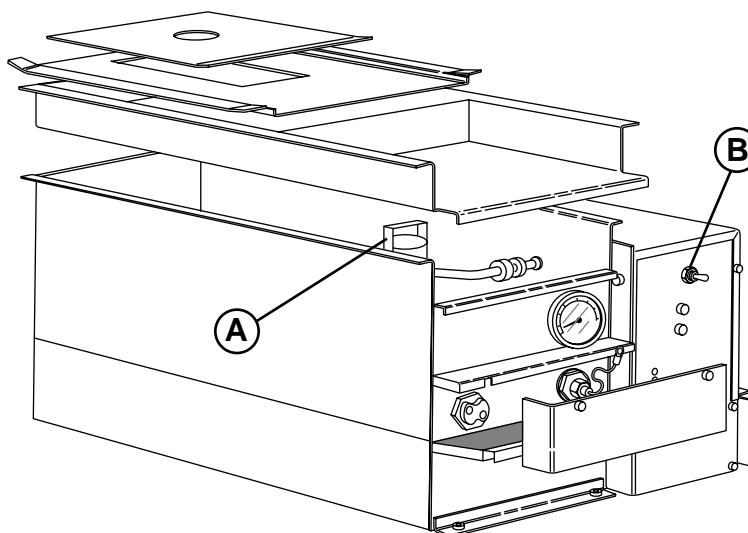

Figure 3 — Wash Tank

### To Fill the Wash Tank

Ensure that the standpipe (A) is in place. Put switch (B) up to the “ON-FILL” position. The water will fill until the proper level is reached. The heating element will then turn on automatically once the tank has filled.

Detergent is fed from the supply container into the detergent tank in controlled amounts by the detergent pump. Use detergent at a strength of 0.35% or as recommended by your chemical supplier.

### To Flush the Wash Tank

The selector switch (B) may be pushed down to the “FLUSH” position to clean the detergent tank during cleaning operations. The glasswasher will not wash dishes in the flush position. To use the flush function: Remove the standpipe (A) and drain the tank. Push the selector switch (B) down to the flush position. Water will enter the detergent tank as long as the switch is held in the “FLUSH” position. When desired flushing is complete, release switch (B).

#### NOTE:

*Use a commercial grade NON-CHLORINATED liquid detergent manufactured specifically for glassware washing machines. Your chemical representative should test the solution to ensure the proper strength to achieve the best cleaning results.*

#### NOTE:

*Many of the chemicals used in glass and dishwashers are harmful to the skin and eyes in their concentrated form. Use extreme caution when handling containers to prevent accidental exposure.*

### Operating Instructions

1. Open front door, flip toggle switch located on wash tank to the “ON-FILL” position. Wash tank will automatically fill.
2. Ensure there is product in the detergent, sanitizer and rinse agent containers.
3. Load glasses on the conveyor. Start machine with round start/stop knob located on the front load side of unit. Machine will now stop with shut-off rod and can be restarted with the round stop/start knob or shut-off rod.

## OPERATION (Cont'd)

### APPROXIMATE CHEMICAL SETTINGS

#### General

Approximate chemical settings can be obtained by counting the revolutions of the injector rotors.

1. For detergent, one revolution per second equals approximately 0.35% concentration.

**NOTE:**

*Detergent pump only operates when hot water tank is filling.*

2. For sanitizer, one revolution in 5 seconds equals approximately 12.5 ppm Iodine or 50 ppm chlorine.
3. For rinse agent, one revolution in 8 seconds is recommended.

#### To Adjust Detergent Injector:

1. When a new detergent container is installed, push the prime button in and hold until the detergent feed tube is full.
2. Install the detergent tank standpipe and switch tank fill toggle switch up to the "ON-FILL" position. The detergent feeder will now feed detergent into the detergent tank with water fill.
3. To increase detergent volume, turn the detergent adjustment screw clockwise.
4. To decrease the detergent volume, turn the detergent adjustment screw counter-clockwise.

#### To Adjust Sanitizer Injector:

1. When a new sanitizer container is installed, push the prime button in and hold until sanitizer feed tube is full.
2. Start the washer with rocker switch located on the front of the machine. Take a sample from the final rinse spray tube to check sanitizer level.
3. To increase the volume of sanitizer, turn the adjustment screw clockwise.
4. To decrease the volume of sanitizer, turn the adjustment screw counter-clockwise.

**NOTE:**

*If Iodopher is being used as a sanitizer, it is not necessary to use a separate rinse agent. To turn rinse agent injector "OFF" in this case, turn the adjustment screw counter-clockwise until the pump stops turning.*

**NOTE:**

---

## OPERATION (Cont'd)

### To Adjust Rinse Agent Injector:

1. When a new rinse agent container is installed, push the prime button in and hold until the rinse injector feed tube is full.
2. Start the washer. Take a sample from the final rinse spray tubes.
3. To increase the volume of rinse agent, turn the adjustment screw clockwise.
4. To decrease the volume of rinse agent, turn the adjustment screw counter-clockwise.

**NOTE:**

*To meet the requirements of N.S.F. standards, Iodophor in a concentration of 12.5 ppm or chlorine at 50 ppm must be used in the final rinse.*

# OPERATION (Cont'd)

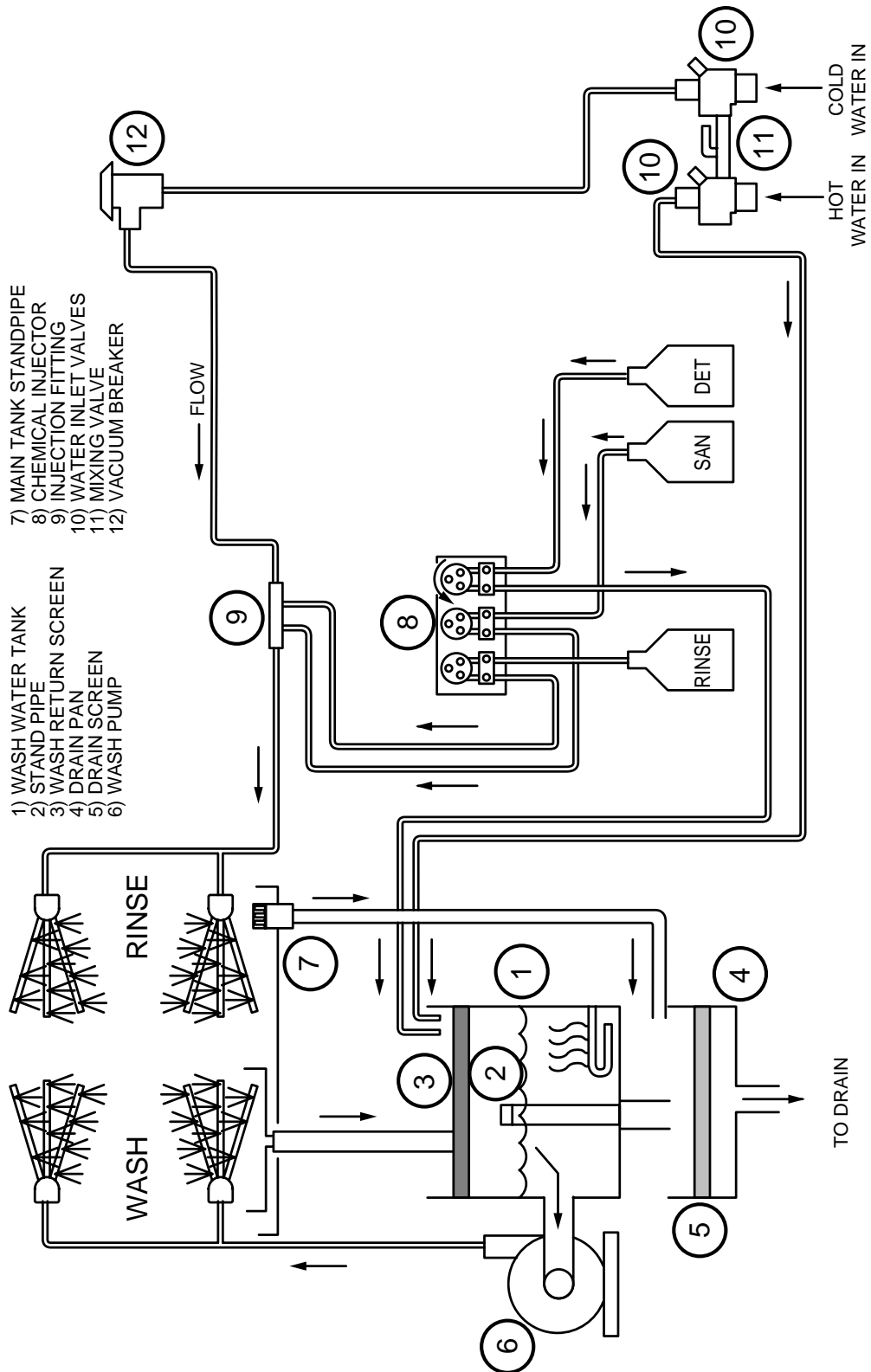

- 7) MAIN TANK STANDPIPE
- 8) CHEMICAL INJECTOR
- 9) INJECTION FITTING
- 10) WATER INLET VALVES
- 11) MIXING VALVE
- 12) VACUUM BREAKER

- 1) WASH WATER TANK
- 2) STAND PIPE
- 3) WASH RETURN SCREEN
- 4) DRAIN PAN
- 5) DRAIN SCREEN
- 6) WASH PUMP

Figure 4 — Plumbing Diagram

# MAINTENANCE

## CLEANING

### Daily Cleaning Instructions

1. Clear the conveyor of glassware and turn glasswasher off by flipping the toggle switch located on the wash tank to the “off” position.
2. Remove load and unload end pick-up plates and splash curtains. Wash them with hot soapy water, rinse thoroughly, then dry.
3. Lift and remove spray hood and set it aside.
4. At *right* hand side of machine, raise conveyor lift bracket to stop position. Remove any debris from catch pan located below spray tubes and in area surrounding overflow tube.
5. Remove overflow tube at right side of upper tank area. Starting at the left side of the machine, flush all debris from left to right side of machine using a wash down nozzle.

**NOTE:**

*Do not leave water in tank overnight!!!*

6. *Replace* overflow tube, lower lift bracket to adjusters and ensure brackets are solidly engaged *over* track adjusters.
7. *Replace* spray hood, ensuring hood hose connections are firmly engaged. Replace curtains and pick-up plates.
8. Remove and clean upper and lower wash tank screens. **Remove** standpipe from the detergent tank; wash down then rinse the interior of the detergent tank.
9. **Replace** stand pipe. **Replace** *both* upper and lower screens.
10. Ensure there is product in the detergent, sanitizer and rinse agent containers. Close doors.

### Weekly Cleaning Instructions

1. Lift and remove front spray-hood cover and open front doors. Remove upper and lower manifold end caps and **clean spray tubes with reamer, tube brush, and tube scraper provided.**
2. Remove detergent, sanitizer, and rinse agent feed lines from containers and place them in a container of hot water. Hold prime buttons in until the feed lines have been thoroughly flushed. Replace the feed lines to their proper container and prime product through lines.

## TROUBLESHOOTING

CONDITION	CAUSE	SOLUTION
Conveyor does not turn	No power .....	Check fuse panel Turn power switch on
	Drive motor burnt out .....	Replace
	Obstruction in wash or rinse .....	Remove obstruction
	Micro-switch on switch support.....	Adjust or replace bracket faulty or not making contact
	Conveyor not in position.....	Position properly
	Conveyor tension too loose.....	Adjust tension with track adjusters
	Conveyor catching on spray.....	Ensure spray tube retaining clips are in tube support position
	Drive sprocket slipping .....	Tighten set screw
	Drive chain too slack .....	Adjust tension
	Drive chain seized or broken .....	Lubricate or replace
	Excessive overspray from hood section	Splash curtain not in position .....
Washer running without any .....		Keep conveyor loaded with glasses glasses on conveyor
Spray tubes at wrong angle.....		Ensure spray tube ends are in slots provided to ensure proper spray angle
Spray tubes plugged.....		Clear and clean with reamer, scraper, and brush
Lack of pressure at wash spray tubes	No water in detergent tank .....	Ensure water supply is on Ensure detergent tank stand pipe is in position Ensure the tank fill switch is in "ON-FILL" position and that tank fills with water Ensure the float switch is activated by the float cam Ensure the tank fill solenoid valve is operational
	Obstruction in wash arm .....	Clear obstruction
	Pump not operating .....	Check power supply to machine Check pump capacitor Replace pump if required
	Pump operating but no pressure.....	Check condition of impeller and stub shaft Replace if needed
	Pump supply line plugged.....	Clear line of cause
	Lack of pressure in rinse spray tubes	Rinse spray tubes dirty.....
Shut-off valve on supply .....		Open valve line closed
Low water pressure .....		Minimum 25PSI flow pressure required
Rinse solenoid valve will .....		Check coil not operate Check and install rebuild kit Replace if necessary
Rinse solenoid valve strainer .....		Remove screen and clean plugged
Water continues to flow to detergent tank or spray tubes with machine off		Solenoid valve not seating .....



CONDITION	CAUSE	SOLUTION	
Water temperature low in detergent tank	Thermostat setting low .....	Adjust thermostat	
	Thermostat defective .....	Replace	
	Defective float switch .....	Replace	
	Heater burnt out .....	Check and replace	
	Incoming water temp. low .....	Ensure water level is above element Hot water supply min. 145°F/66°C	
Water on floor around machine	Pump seal leaking .....	Replace	
	Rinse drain in wash area plugged .....	Clear obstruction, clean machine	
	Wash return screen in detergent tank plugged .....	Clean	
	Drain screen under detergent tank plugged .....	Clean	
	Main drain plugged .....	Clean	
	Detergent tank covers are not positioned properly causing condensation .....	Position all top covers to completely cover top of tank	
	Fill chute has lime build-up .....	De-scale detergent tank	
	Spray tube clean out caps loose or o-rings damaged .....	Tighten caps Replace o-rings	
	Chemical containers filling with water	Dirty rinse tubes .....	Refer to cleaning section
		Element tube worn .....	Replace
Worn flow washer in solenoid valve .....		Replace	
Chemicals not feeding	No product in containers .....	Refill container	
	Product gelling or crystallizing in chemical line .....	Flush all lines with hot water and use fresh supply of chemical	
	Chemical supply strainer plugged .....	Clean with hot water	
	Speed adjustment set too low .....	Increase by turning clockwise while machine is running/filling	
	No power to pump .....	Check power LED on chemical control board Check signal LED for detergent, sanitize/rinse on board Replace board if necessary	
	Pump motor defective .....	Replace pump motor	
	Element tube stretched .....	Replace	



# REPLACEMENT PARTS

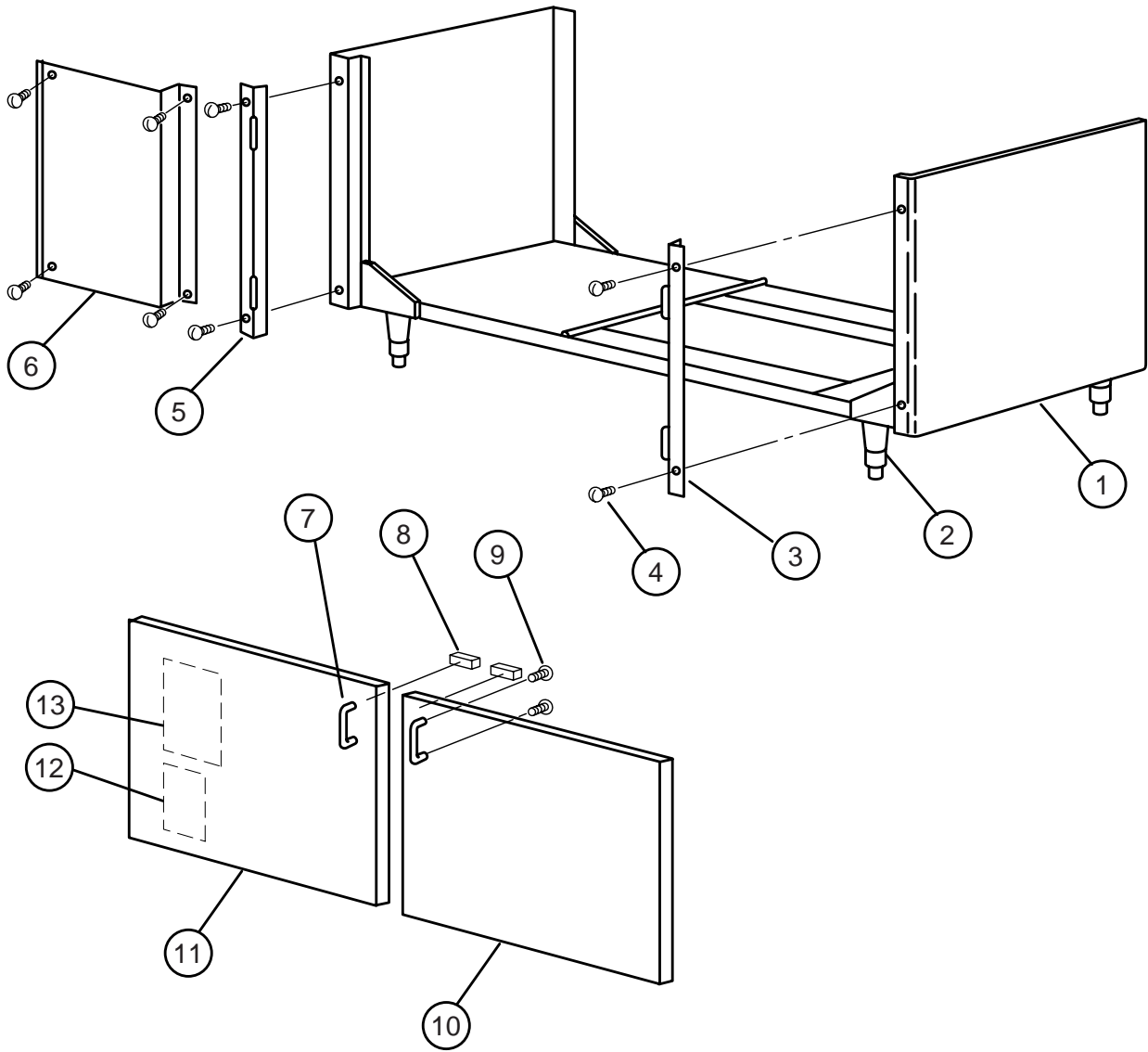

Figure 5 — Main Frame Assembly

## MAIN FRAME ASSEMBLY

<b>Fig. 5 Item No.</b>	<b>Part No.</b>	<b>Part Description</b>	<b>Qty.</b>
1	0707561	Frame Assembly, SW600.....	1
1	0707673	Frame Assembly, SW400.....	1
2	0501873	Grey Cast Foot .....	4
3	0703003	Hinge Rail, Right Side .....	1
4	0501412	Screw, 10-32 x 3/8" .....	8
5	0703002	Hinge Rail, Left Side .....	1
6	0308100	Front Side Panel, SW600 only.....	2
7	0501921	Door Handle .....	2
8	0501885	Magnetic Door Catch .....	2
9	0501464	Screw, 10-24 x 3/8" .....	4
10	0707514	Door Assembly, Right Hand .....	1
11	0707515	Door Assembly, Left Hand .....	1
12	0507836	Label, Wiring Schematic.....	1
13	0507582	Label, Cleaning .....	1

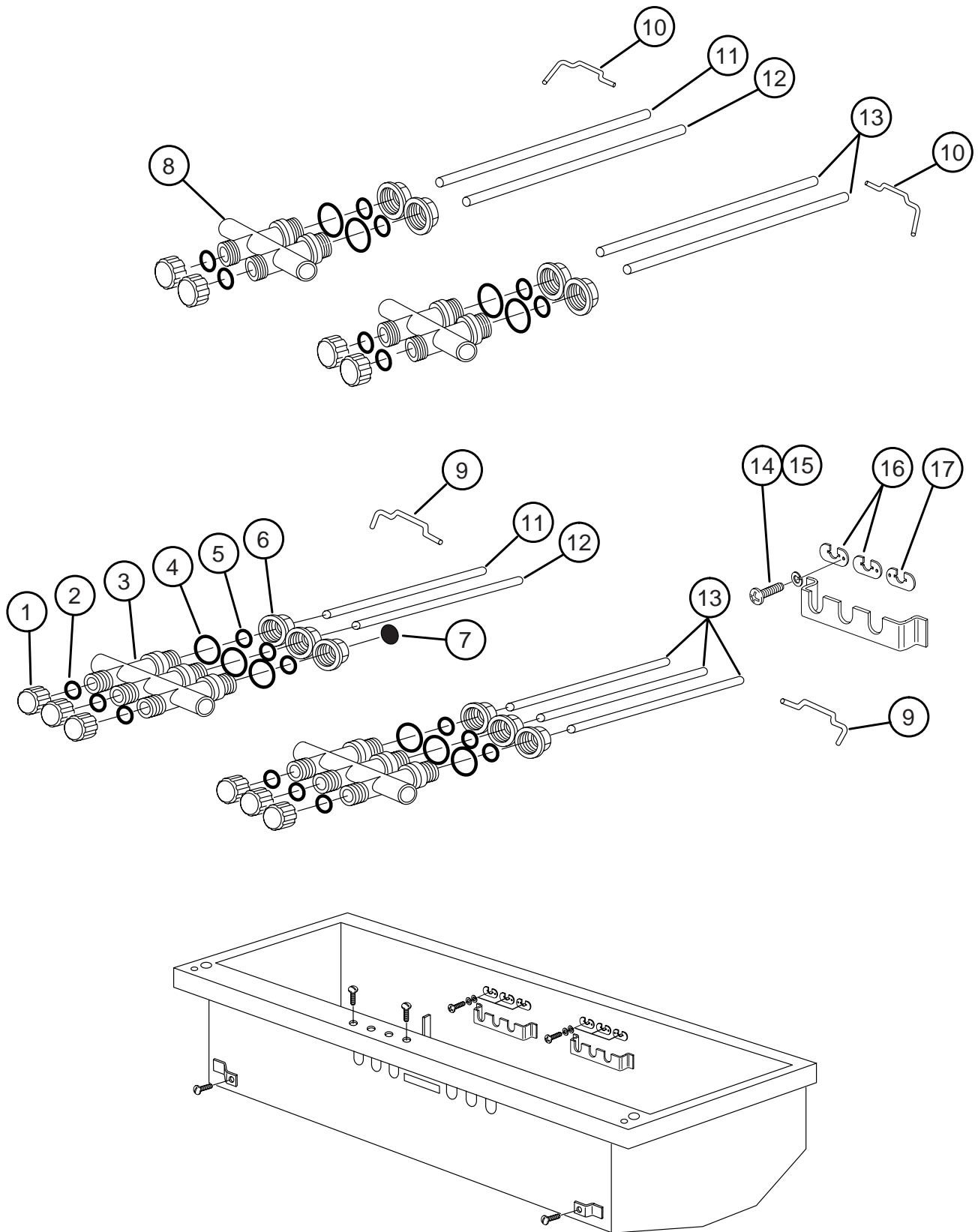

Figure 6 — Spray Assembly

---

**SPRAY ASSEMBLY**

<b>Fig. 6 Item No.</b>	<b>Part No.</b>	<b>Part Description</b>	<b>Qty.</b>
1	0501746	Manifold Cap .....	10
2	0501753	O-Ring .....	10
3	0301790	Manifold, Triple .....	2
4	0501745	O-Ring .....	10
5	0503589	O-Ring .....	10
6	0501716	Manifold Retaining Nut .....	10
7	0307502	Manifold Plug.....	1
8	0301795	Manifold, Double .....	2
9	0303009	Retaining Rod, Triple.....	2
10	0303010	Retaining Rod, Double .....	2
11	0501718	Spray Tube, Rinse (14 Holes) .....	2
12	0501719	Spray Tube, Rinse (13 Holes) .....	2
13	0501717	Spray Tube, Wash .....	5
14	0501407	Screw, 8-32 x 1/4" .....	10
15	0501497	Washer, Lock .....	10
16	0303091	Retainer, L.H. ....	6
17	0303092	Retainer, R.H.....	4

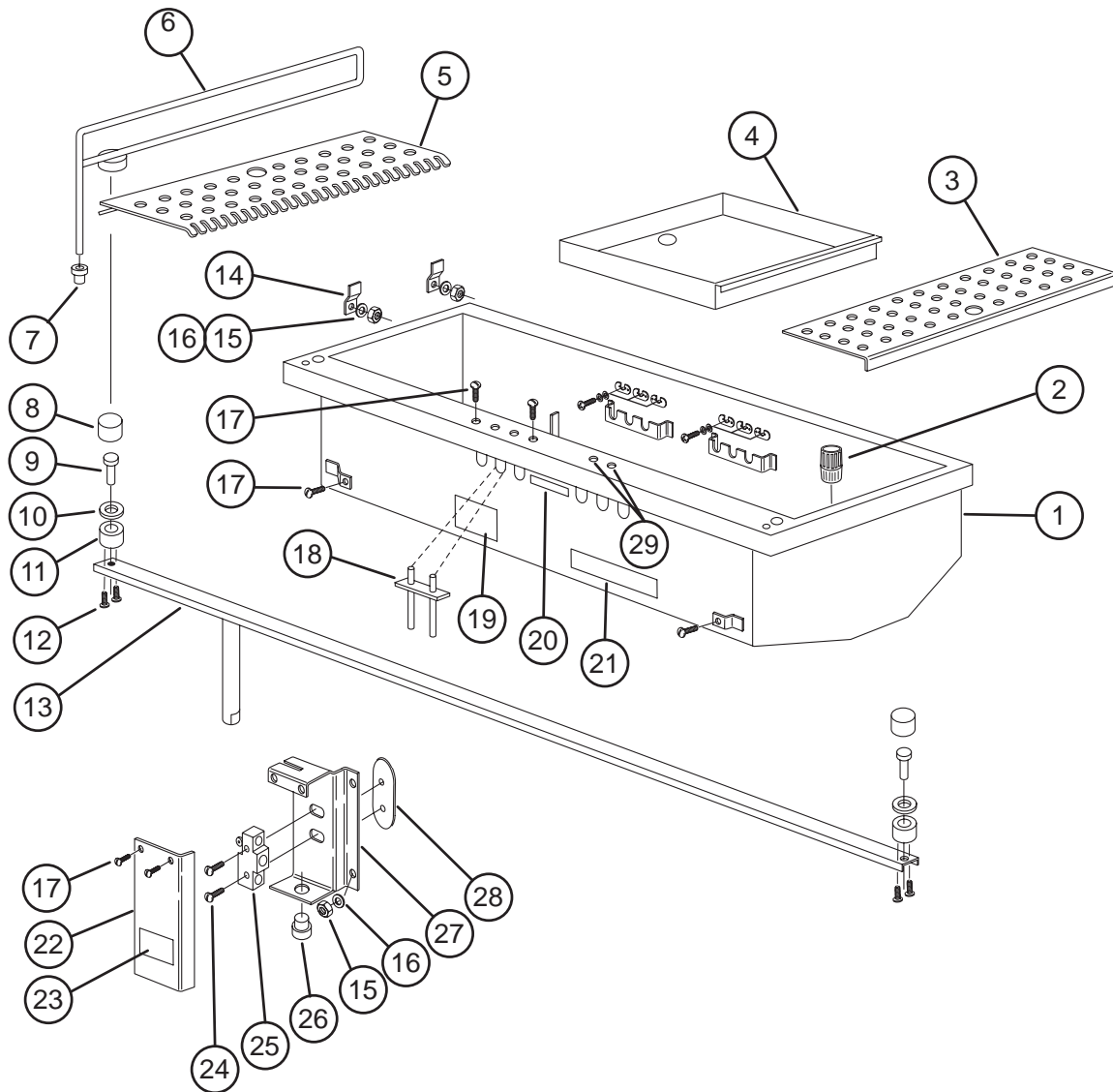

Figure 7 — Main Tank Assembly (R-L Shown)



## MAIN TANK ASSEMBLY

<b>Fig. 7 Item No.</b>	<b>Part No.</b>	<b>Part Description</b>	<b>Qty.</b>
1	0707562	Main Tank, SW600 .....	1
1	0707497	Main Tank, SW400 .....	1
2	0707498	Main Tank Standpipe .....	1
3	0303221	Pick Up Plate, Load End.....	1
4	0307500	Wash Return Pan .....	1
5	0303224	Pick Up Plate, Slotted, Unload End.....	1
6	0707485	Shut-off Rod.....	1
7	0501736	Bushing, Shut-off Rod .....	2
8	0501728	Pivot Cap.....	2
9	0501721	Pivot, Activator Channel.....	2
10	0302975	Slide Washer.....	2
11	0501727	Activator Channel Guide .....	2
12	0501408	Screw, 8-32 x 1/4".....	4
13	0707576	Activator Channel, SW600 .....	1
13	0707503	Activator Channel, SW400 .....	1
14	0307518	Retainer, for Pick-up Plate .....	4
15	0501539	Nut, 1/4-20 .....	4
16	0501501	Lock Washer, 1/4" .....	4
17	0501412	Screw, 10-32 x 3/8" .....	4
18	0703080	Disconnect Tube Assembly.....	1
19	0504825	Label, Rating.....	1
20	0302970	Door Catch Plate .....	1
21	0507583	Label, Caution .....	1
22	0307489	Switch Cover, SW600.....	1
22	0307488	Switch and Chain Cover, SW400 .....	1
23	0503301	Label, (disconnect from supply) .....	1
24	0503723	Screw, 6-32 x 1" .....	2
25	0501375	Trip Switch.....	1
26	0503574	Strain Relief Bushing.....	1
27	0307506	Activating Switch Bracket .....	1
28	0502977	Dual Weld Nut, 6-32 .....	1
29	107964	Bushing, snap 1/2" .....	2
—	0507493	Insulation, tank (CG4) .....	1
—	0507587	Insulation, tank (CG6) .....	2

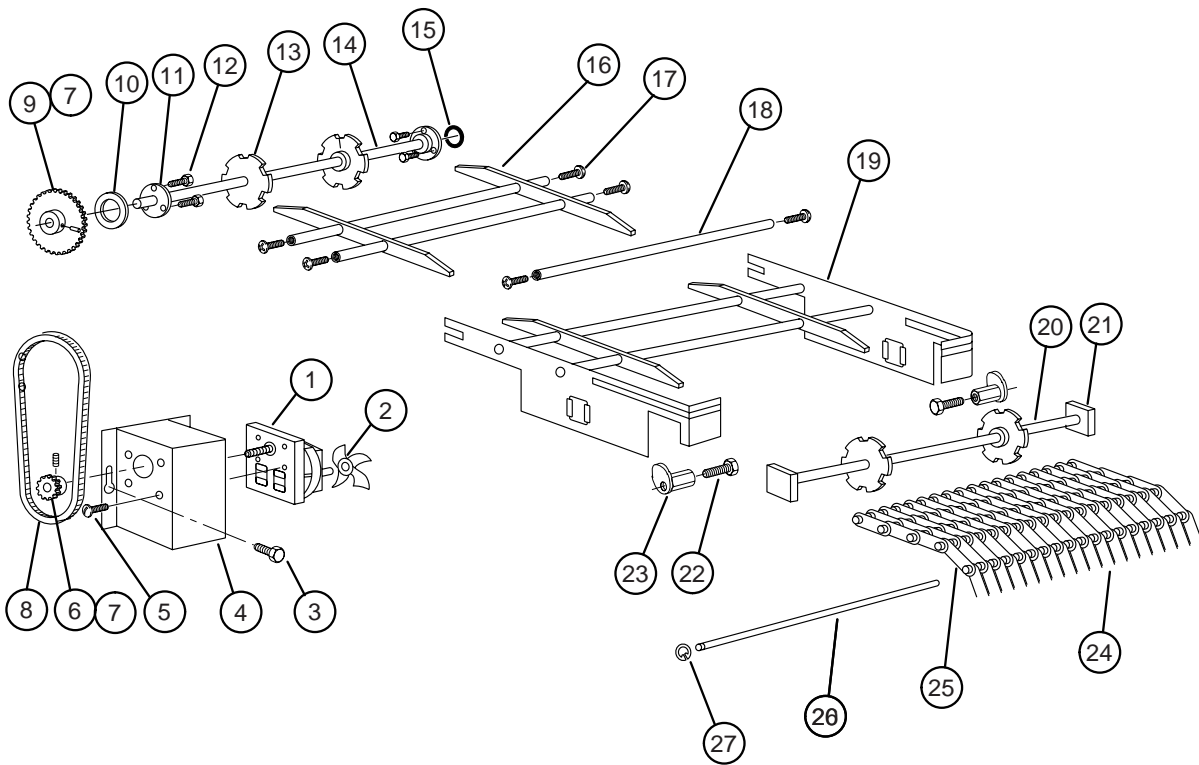

Figure 8 — Lift Bracket and Drive Assembly

## LIFT BRACKET AND DRIVE ASSEMBLY

<b>Fig. 8 Item No.</b>	<b>Part No.</b>	<b>Part Description</b>	<b>Qty.</b>
1	0501345	Drive Motor, 230 Volt c/w Fan .....	1
2	0501355	Motor Fan, 2-5/8" Dia.....	1
3	0501456	Bolt, 1/4-20 x 1/2" .....	3
4	0702979	Motor Mount Assembly .....	1
5	0501408	Screw, 8-32 x 1/4".....	4
6	0501793	Sprocket, 16 Tooth c/w Set Screw .....	1
7	0501395	Set Screw, 1/4-20 x 5/16" .....	2
8	0501899	Drive Chain .....	1
9	0501706	Sprocket, 54 Tooth c/w Set Screw .....	1
10	0501731	Spacer, Drive Shaft .....	1
11	0501729	Drive Shaft Bushing.....	2
12	0501419	Screw, 1/4-20 x 1/2".....	6
13	0501710	Sprocket, Conveyor.....	4
14	0501732	Drive Shaft, 5/8" Dia .....	1
15	0501702	Retaining Ring .....	1
16	0704576	Slide Rail Assembly, SW600.....	1
16	0703029	Slide Rail Assembly, SW400.....	1
17	0501418	Screw, 1/4-20 x 1/2".....	6
18	0501593	Cross Rod.....	2
19	0703213	Lift Bracket Assembly, SW600 .....	1
19	0703154	Lift Bracket Assembly, SW400 .....	1
20	0501733	Idler Shaft, 2 - 5/8" Dia.....	1
21	0501722	Bushing, Idler Shaft .....	2
22	0501420	Bolt, 1/4-20 x 1".....	2
23	0701724	Cam, Belt Adjustment.....	2
24	0503401	Conveyor Belt, SW600 .....	1
24	0503705	Conveyor Belt, SW400 .....	1
25	0501590	Conveyor Belt Link, SW600.....	1596
25	0501590	Conveyor Belt Link, SW400.....	1036
26	0501589	Conveyor Rod, SW600 .....	57
26	0501589	Conveyor Rod, SW400 .....	37
27	0503664	Retaining Ring, SW600 .....	114
27	0503664	Retaining Ring, SW400 .....	74
—	0704862	Idler Shaft Assembly, (items 13, 20, 21) .....	1
—	0704863	Drive Shaft Assembly, (items 9 - 15) .....	1

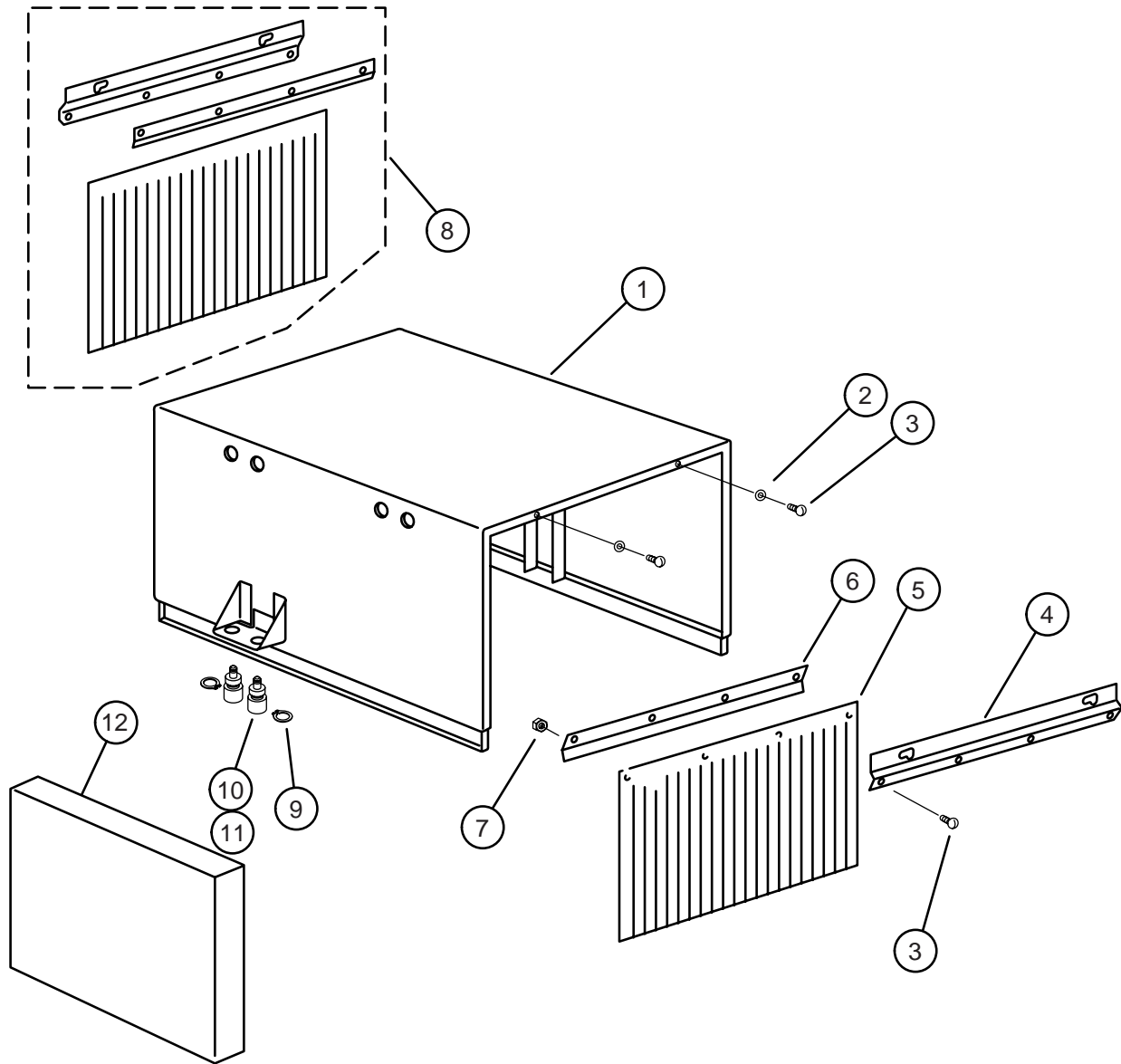

Figure 9 — Hood Assembly

## HOOD ASSEMBLY

<b>Fig. 9 Item No.</b>	<b>Part No.</b>	<b>Part Description</b>	<b>Qty.</b>
1	0703244	Hood, with vacuum breaker at rear.....	1
1	0708681	Hood, with vacuum breaker at front .....	1
2	0501497	Lock Washer, #8.....	4
3	0501408	Screw, 8-32 x 1/4".....	12
4	0302997	Curtain Bracket, Outer .....	2
5	0501743	Curtain .....	2
6	0302998	Curtain Bracket, Inner .....	2
7	0501538	Nut, 8-32 .....	4
8	0703176	Curtain Assembly Complete .....	2
9	0507011	Retaining Ring .....	2
10	0703702	Disconnect Assembly .....	2
11	0503703	O-Ring for Disconnect .....	2
12	0703078	Plumbing Cover .....	1

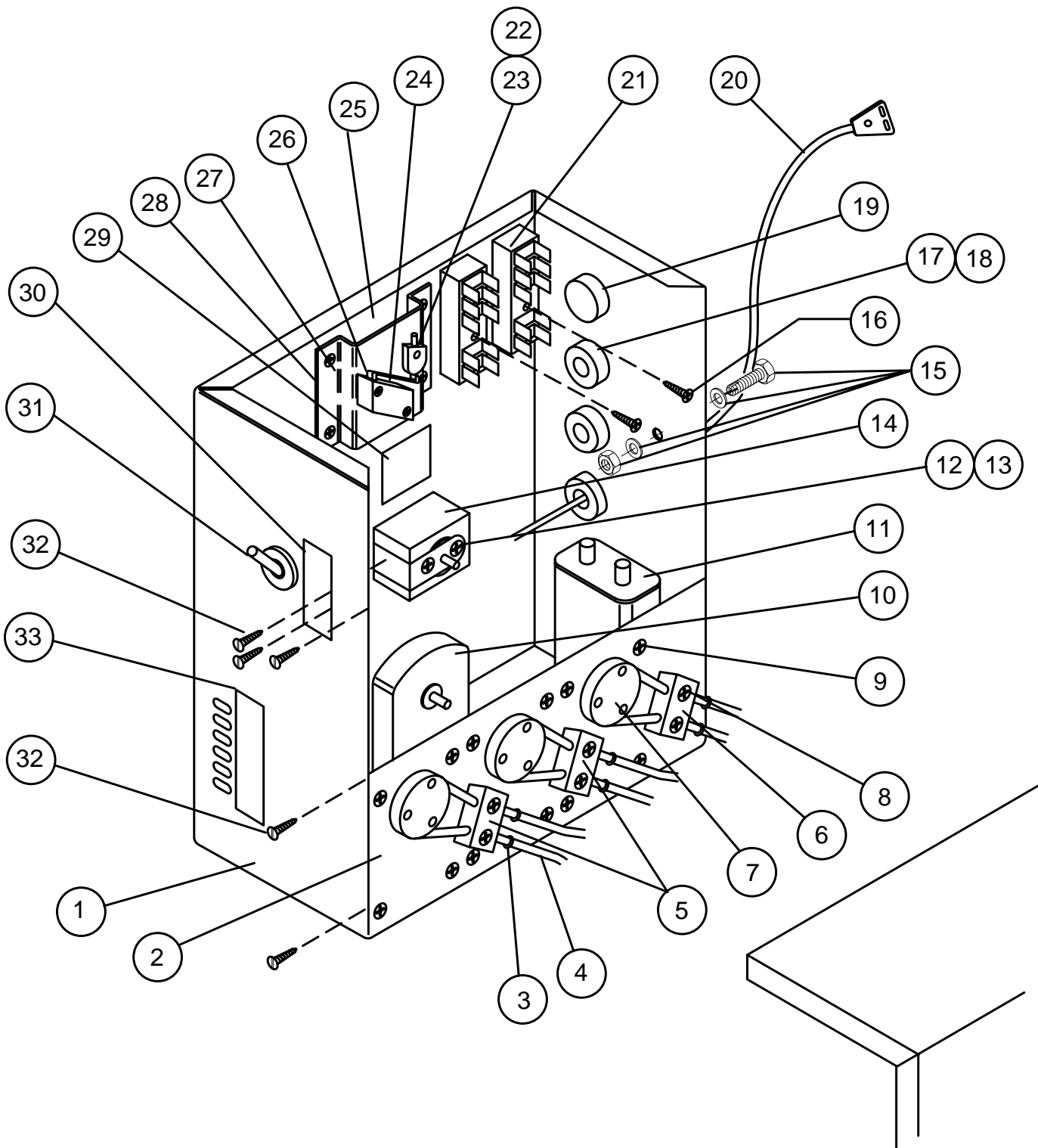

Figure 10 — Control Box

## CONTROL BOX

<b>Fig. 10 Item No.</b>	<b>Part No.</b>	<b>Part Description</b>	<b>Qty.</b>
1	0707403	Control Box (prior to S/N 6226).....	1
1	0709049	Control Box (starting @ S/N 6226).....	1
2	0307405	Injector Motor Plate .....	1
3	0501519	Tie, Nylon 4 in .....	6
4	0502666	Hose (1/8" I.D. x 1/4" O.D.).....	AR
5	0706635	45CC Element Tube.....	2
6	0706634	15CC Element Tube.....	1
7	0707142	Rotor Assembly.....	3
8	0506589	Screw, 6-32 x 7/8".....	6
9	0504822	Screw, 8-32 x 1/2".....	12
10	0501353	Chemical Injector Motor.....	3
11	0507314	Start Capacitor (3 uF).....	1
12	0307422	Thermostat Bracket .....	1
13	0501450	Screw, 6-32 x 3/16".....	4
14	0507323	Thermostat.....	1
15	0503592	Label, Ground .....	1
15	0501403	Screw, Ground, 10-32 x 3/4" .....	2
15	0501533	Nut, Ground, 10-32.....	2
15	0501493	Washer, Lock, Ground, #10 .....	2
15	0501472	Washer, Flat, Ground .....	3
16	0503648	Screw, 8-32 x 5/16".....	2
17	0503647	Strain Relief Bushing (Medium).....	1
18	0503574	Strain Relief Bushing (Small).....	2
19	0501887	7/8" Button Plug.....	1
20	0507372	Power Cord.....	1
21	0503749	Terminal Board.....	2
22	0701933	Water/Heater Cam c/w Set Screw.....	1
23	0501397	Set Screw, 6-40 x 3/16".....	1
24	0501379	Float Switch .....	1
25	0307369	Nut Plate for Float Switch (starting @ S/N 6226).....	1
26	0501433	Screw, 4-40 x 5/8".....	2
27	0501411	Screw, 10-32 x 1/4".....	8
28	0309053	Float Switch Support (starting @ S/N 6226).....	1
29	0503642	Label, 2.5 Amp Fuse.....	1
30	0503693	Label, Switch Up.....	1
31	0501373	3-Position Switch .....	1
32	0501412	Screw, 10-32 x 3/8".....	8
33	0507470	Label, Injector Prime.....	1

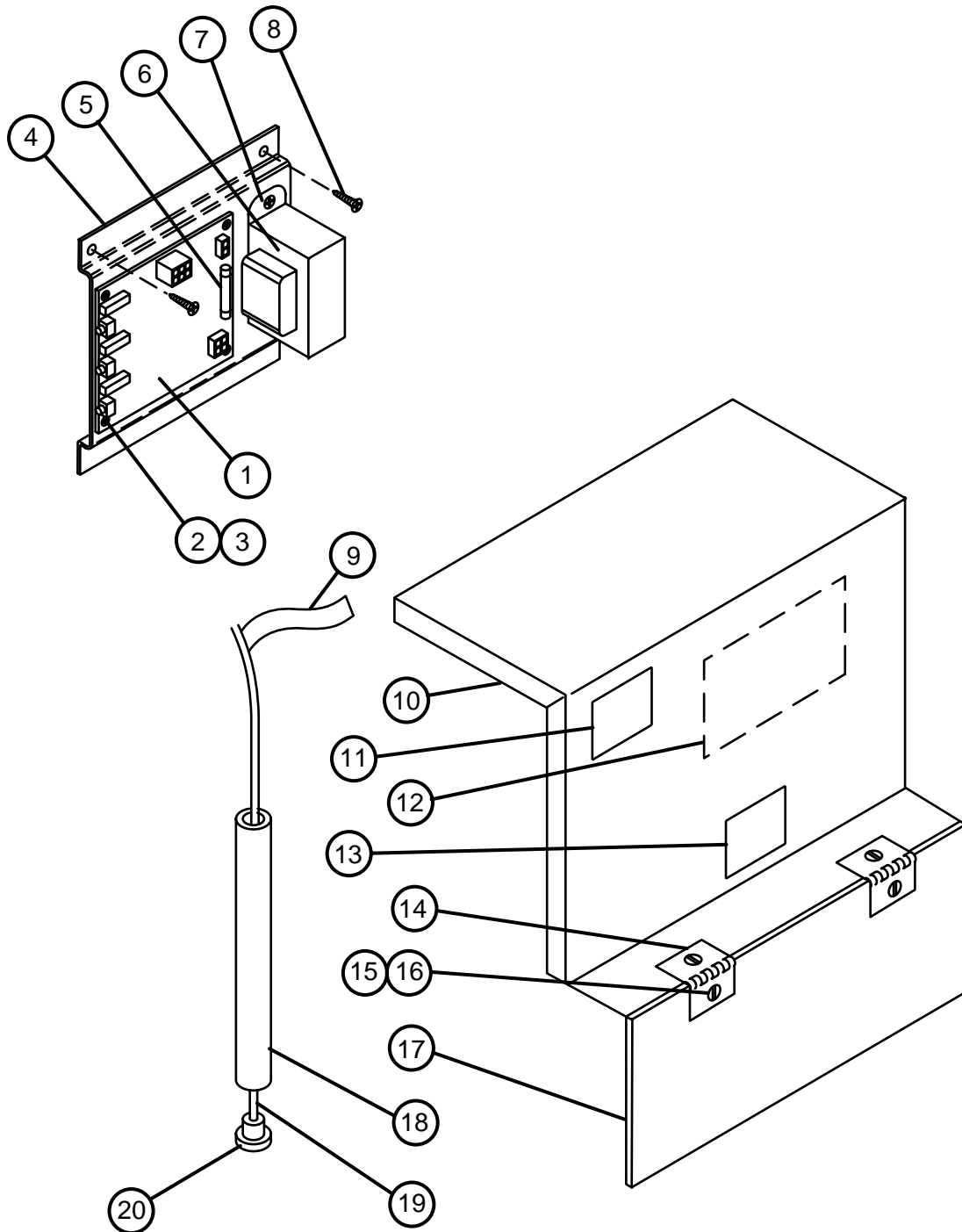

Figure 11 — Control Box Cover/Chemical Injector Board



## CONTROL BOX COVER/CHEMICAL INJECTOR BOARD

Fig. 11 Item No.	Part No.	Part Description	Qty.
1	0508433	Circuit Board (starting @ S/N 6216).....	1
2	106695	Screw, 6-32 x 1/2".....	4
3	0508710	Spacer, 5/16 lg.....	4
4	0309037	Support Bracket (starting @ S/N 6216).....	1
5	0503637	Fuse, 2.5 Amp .....	1
6	0508920	Transformer (starting @ S/N 6216) .....	1
7	0501450	Screw, 6-32 x 3/16".....	4
8	0501411	Screw, 10-32 x 1/4".....	2
9	0503695	Label, Detergent.....	1
9	0505483	Label, Rinse.....	1
9	0503694	Label, Sanitizer .....	1
10	0307408	Control Box Cover (prior to S/N 6226).....	1
10	0309052	Control Box Cover (starting @ S/N 6226).....	1
11	0503301	Label, Warning .....	1
12	0509061	Label, Circuit Board (starting @ S/N 6216).....	1
13	0503343	Label, Warranty Void .....	1
14	0300986	Hinge, Cover .....	2
15	0501408	Screw, 8-32 x 1/4".....	4
16	0501538	Nut, 10-32 .....	4
17	0307409	Injector Pump Cover .....	1
18	0306363	Dip Tube.....	3
19	0502666	Hose, 1/8" I.D. x 1/4" O.D.....	AR
20	0501869	Strainer .....	3
NS	0507577	Wiring Harness (Drive Motor, Solenoid Valves).....	1
NS	0507578	Wiring Harness, Circuit Board (prior to S/N 6216) .....	1
NS	0509039	Wiring Harness, Circuit Board (starting @ S/N 6216).....	1
NS	0503739	Aluminum Spacer, Float Switch (prior to S/N 6226).....	2

 **NOTE:**

*The circuit board shown in this diagram started at S/N 6216. Prior units will require circuit board conversion kit P/N 0708523. Once this kit has been installed, all replacement parts except the wiring harness will be as shown. Replacement wiring harness for circuit board kit is P/N 0509038.*

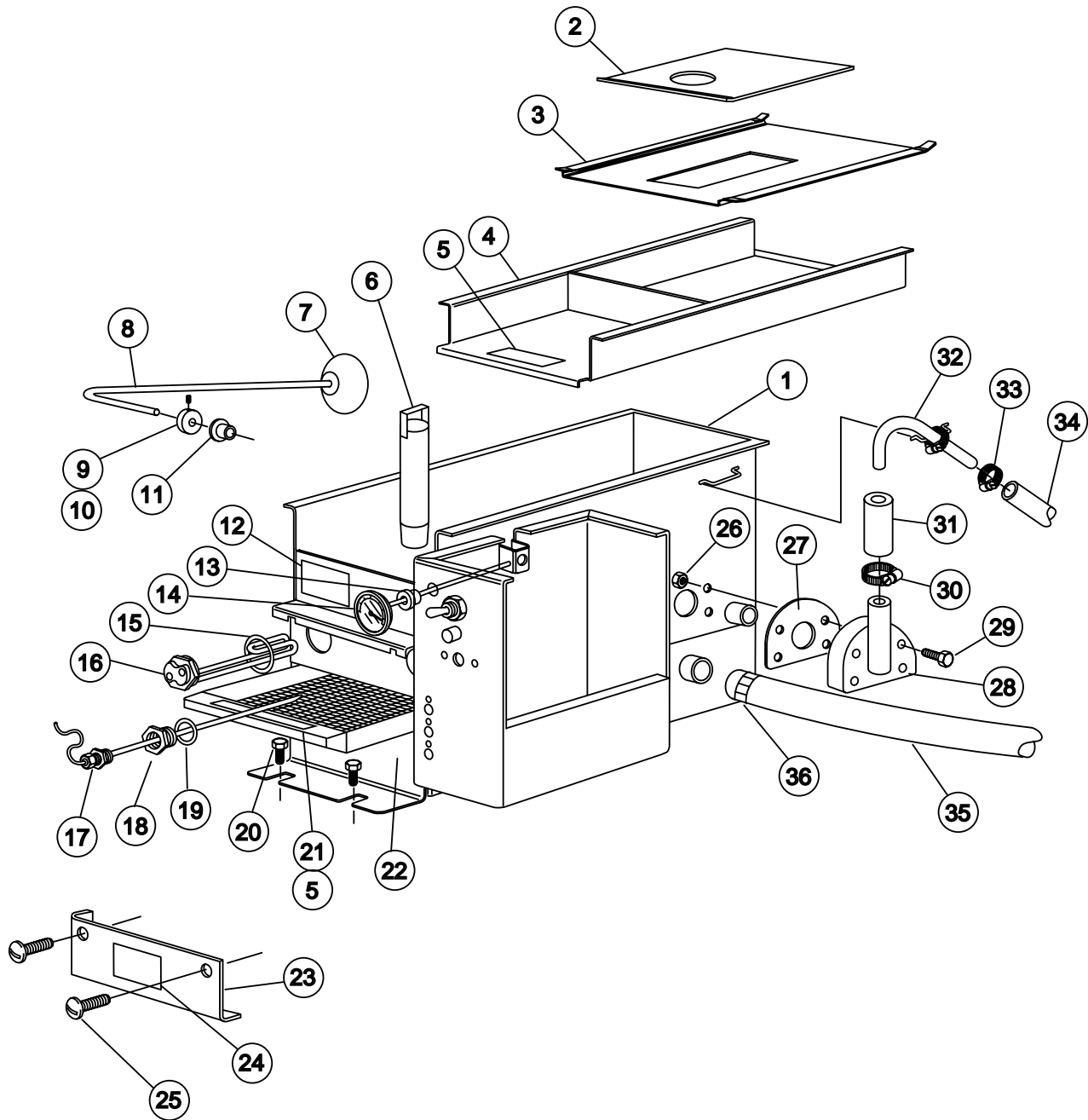

Figure 12 — Detergent Tank

**DETERGENT TANK**

<b>Fig. 12 Item No.</b>	<b>Part No.</b>	<b>Part Description</b>	<b>Qty.</b>
1	0707415	Detergent Tank (up to S/N 6226).....	1
1	0709054	Detergent Tank (starting @ S/N 6226) .....	1
2	0307296	Detergent Tank Cover Lid.....	1
3	0307378	Detergent Tank Rear Cover.....	1
4	0707375	Detergent Tank Screen Assembly .....	1
5	0507471	Label, Clean Screens Daily .....	2
6	0700948	Standpipe Assembly.....	1
7	0503670	Float Ball.....	1
8	0507426	Float Rod.....	1
9	0703673	Cam Bushing c/w Set Screw.....	1
10	0501397	Set Screw, 6-40 x 3/16".....	1
11	0503701	Timer Shaft Bearing (not req'd after S/N 6226).....	2
12	0504864	Label, Data .....	1
13	0501896	Thermometer Seal .....	1
14	0501600	8" Thermometer .....	1
15	0503588	Heater "O" Ring .....	1
16	0507315	3 KW Heater c/w "O" Ring .....	1
17	0507323	Thermostat (Capillary only shown) .....	1
18	0501650	Thermostat Adaptor .....	1
19	0501836	Adaptor "O" Ring .....	1
20	0501419	Bolt, 1/4-20 x 1/2" .....	1
21	0707383	Drain Pan Screen Assembly.....	1
22	0707380	Drain Pan Assembly.....	1
23	0307423	Heater Cover .....	1
24	0503301	Label, Warning .....	1
25	0501412	Screw, 10-32 x 3/8" .....	2
26	107435	Nut, M6 .....	4
27	107886	Inlet Chute Gasket.....	1
28	108051	Elbow Flange .....	1
29	0507431	Bolt, M6 x 25mm.....	4
30	0502563	1" Gear Clamp.....	1
31	0502668	1" I.D. Braided Hose.....	AR
32	0307427	Inlet Water Tube.....	1
33	0503679	7/16" Gear Clamp .....	2
34	0502665	1/2" I.D. Braided Hose.....	1
35	0502662	1-1/2" Vac-U-Flex Hose.....	23"
36	0502571	1-1/2" Clamp, Hose.....	1

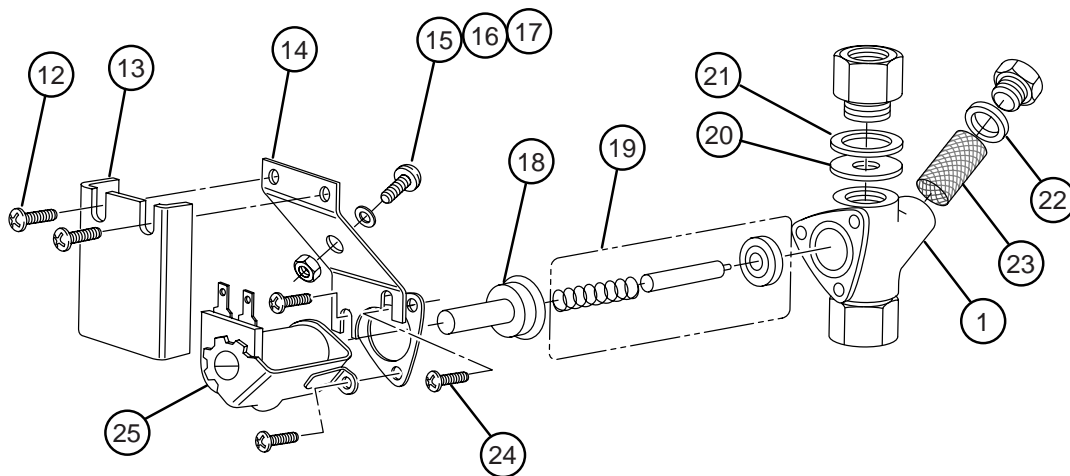
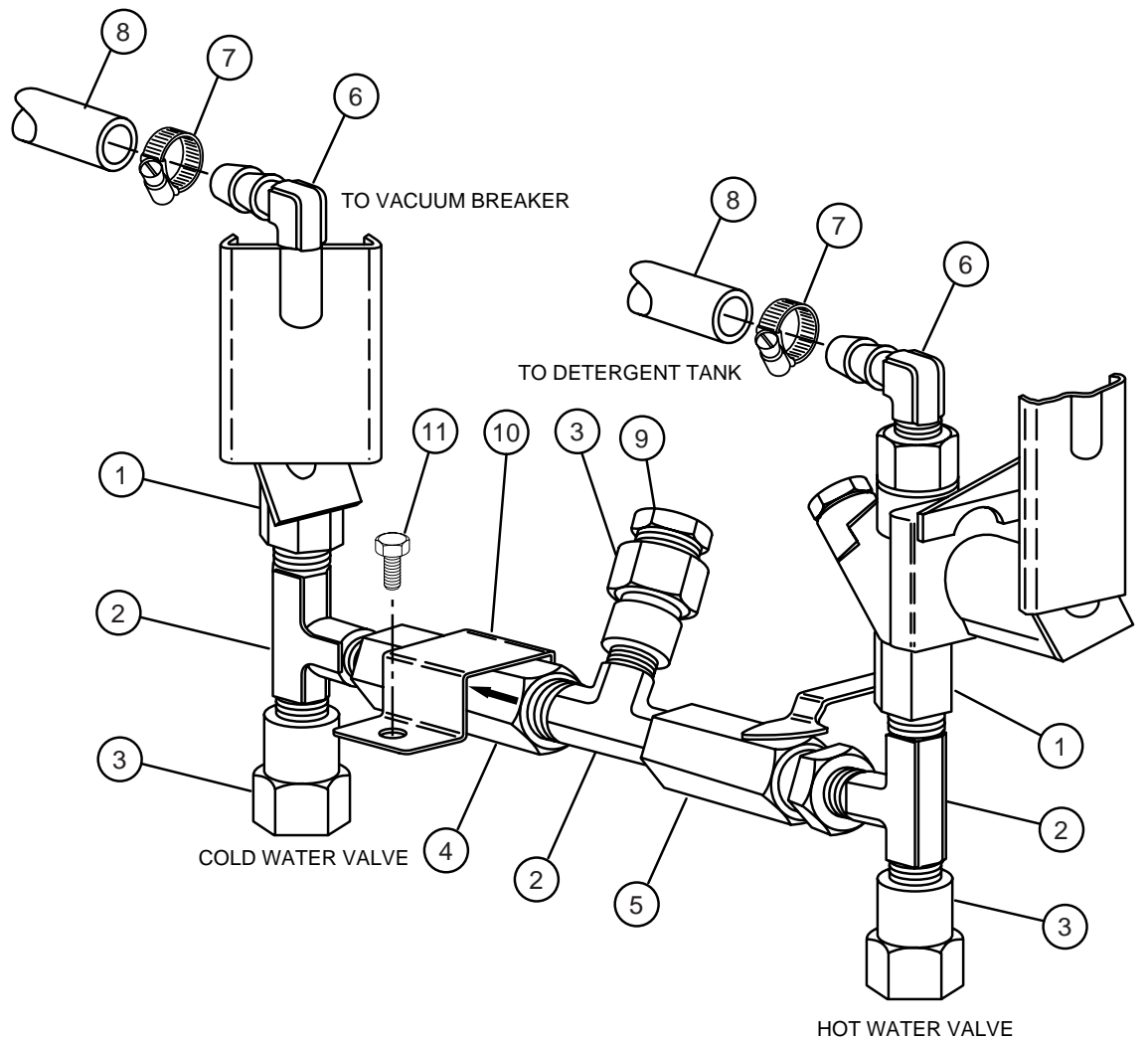

Figure 13 — Inlet Plumbing

## INLET PLUMBING

<b>Fig. 13 Item No.</b>	<b>Part No.</b>	<b>Part Description</b>	<b>Qty.</b>
1	0502783	230V 60HZ Solenoid Valve .....	2
2	0503802	3/8" MPT Tee .....	3
3	0503801	3/8" Fem x 1/2" Fem Adapter .....	2
4	0507324	3/8" Check Valve .....	1
5	0502768	Mixing Valve .....	1
6	0502653	3/8" x 1/2" 90° Hose Barb .....	2
7	0503679	7/16" Gear Clamp .....	2
8	0502665	1/2" I.D. Braided Hose .....	AR
9	0509659	Brass Cap .....	1
10	0307688	Inlet Plumbing Clamp .....	1
11	0501419	Bolt, 1/4-20 x 1/2" .....	2
12	0504822	Screw, 8-32 x 1/2" .....	2
13	0306208	Cable Clamp Cover .....	1
14	0307373	Cable Clamp Assembly .....	1
15	0501404	Screw, 10-32 x 3/8", Brass .....	2
16	0501493	Lock Washer, #10 .....	2
17	0501533	Nut, 10-32, Brass .....	2
18	0505229	Solenoid Guide .....	1
19	0502811	Diaphragm Kit .....	AR
20	0502810	Flow Washer (2.6 GPM) .....	1
21	0502807	Washer, Brass .....	1
22	0502804	Washer, Brass .....	1
23	0502803	Screen .....	1
24	0501406	Screw, 8-32 x 1/2" .....	2
25	0502806	Coil -230V 60HZ .....	1

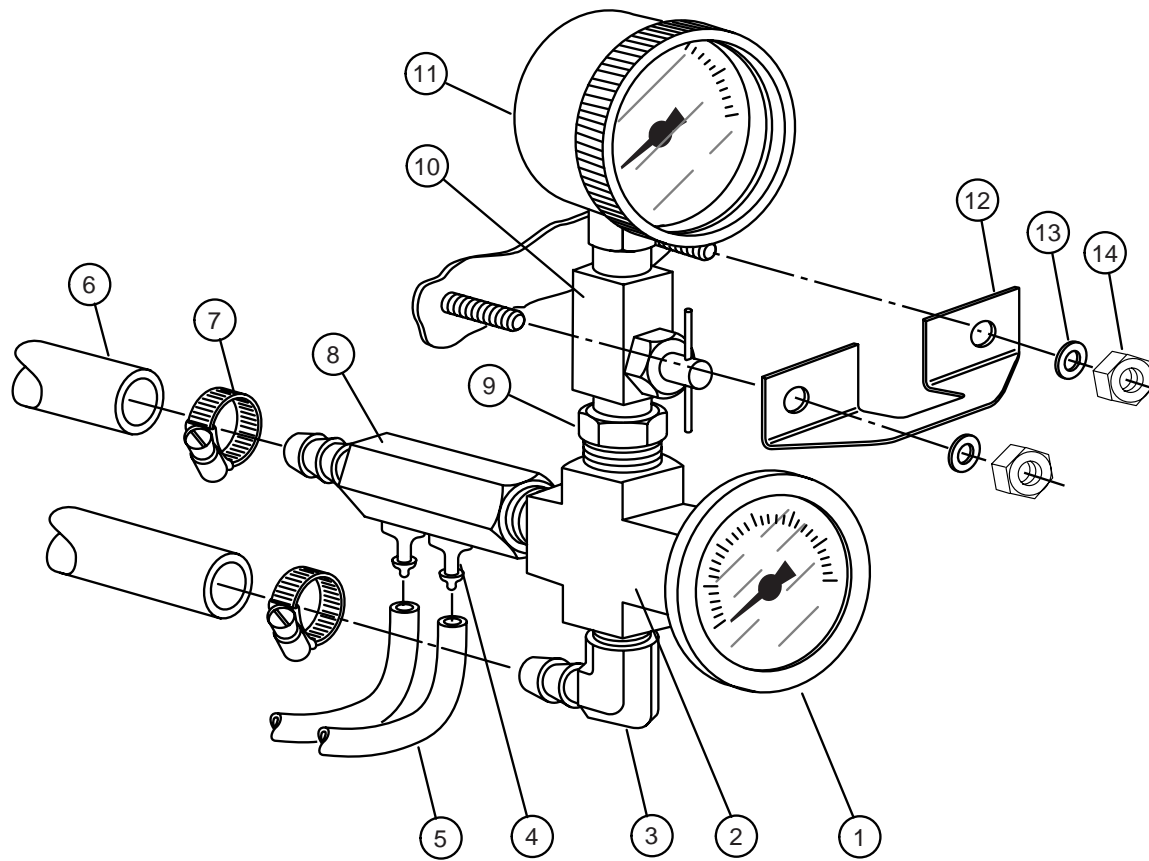

Figure 14 — Sanitizer Plumbing

## SANITIZER PLUMBING

<b>Fig. 14 Item No.</b>	<b>Part No.</b>	<b>Part Description</b>	<b>Qty.</b>
1	0503668	Thermometer .....	1
2	0502583	3/8" FPT Cross Connector .....	1
3	0502653	3/8" MPT x 1/2" 90° Hose Barb .....	1
4	0502645	1/8" Hose Barb .....	2
5	0502666	1/8" Hose .....	AR
6	0502665	1/2" I.D. Braided Hose .....	AR
7	0503679	7/16" Gear Clamp .....	2
8	0503669	Injector Barb Fitting .....	1
9	0502577	3/8 x 1/4 MPT Reducer Bushing .....	1
10	0502781	Needle Valve .....	1
11	0507100	0-30 PSI Pressure Gauge .....	1
12	0300918	Plumbing Clamp .....	1
13	0501501	Lock Washer, 1/4" .....	2
14	0501539	Nut, 1/4-20 .....	2

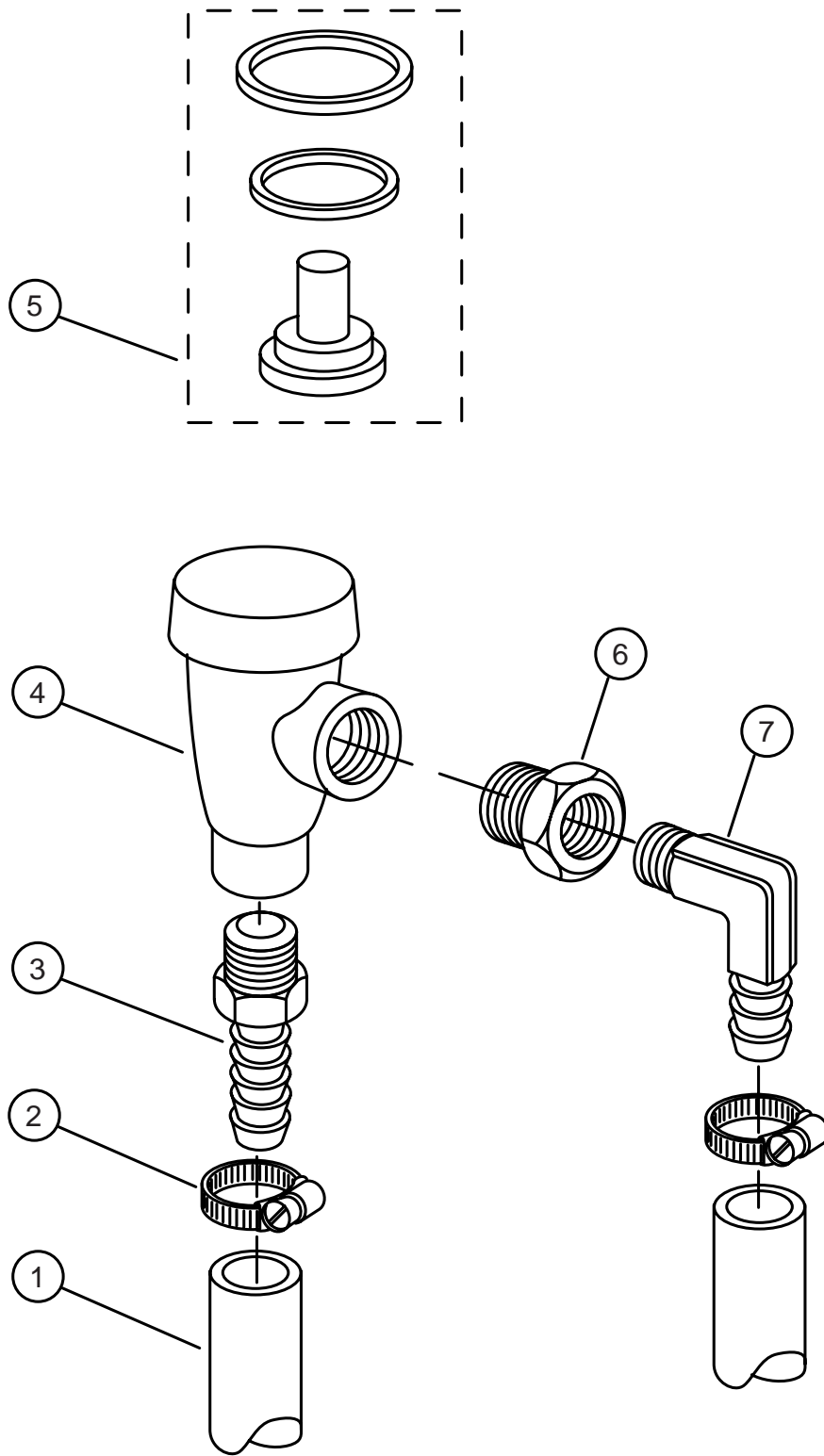

Figure 15 — Vacuum Breaker Plumbing



## VACUUM BREAKER PLUMBING

<b>Fig. 15 Item No.</b>	<b>Part No.</b>	<b>Part Description</b>	<b>Qty.</b>
1	0502665	1/2" x 3/4" Inner Braided Tubing .....	AR
2	0503679	7/16" Gear Clamp .....	2
3	0502651	1/2" MPT x 1/2" Hose Barb.....	1
4	0502751	1/2" Vacuum Breaker (Prior to S/N G2182).....	1
5	0508366	Vac Breaker Kit (Prior to S/N G2182).....	AR
6	0502650	1/2" x 3/8" Reducer Bushing .....	1
7	0502653	3/8" MPT x 1/2" 90° Hose Barb.....	1
8	113220	1/2" vacuum breaker .....	1
		(Beginning with S/N G2182 and above)	
9	113221	Repair kit, vacuum breaker .....	1
		(Beginning with S/N G2182 and above)	

 **NOTE:**

*Watts vacuum breaker repair kit is not available . . . use item #4.*

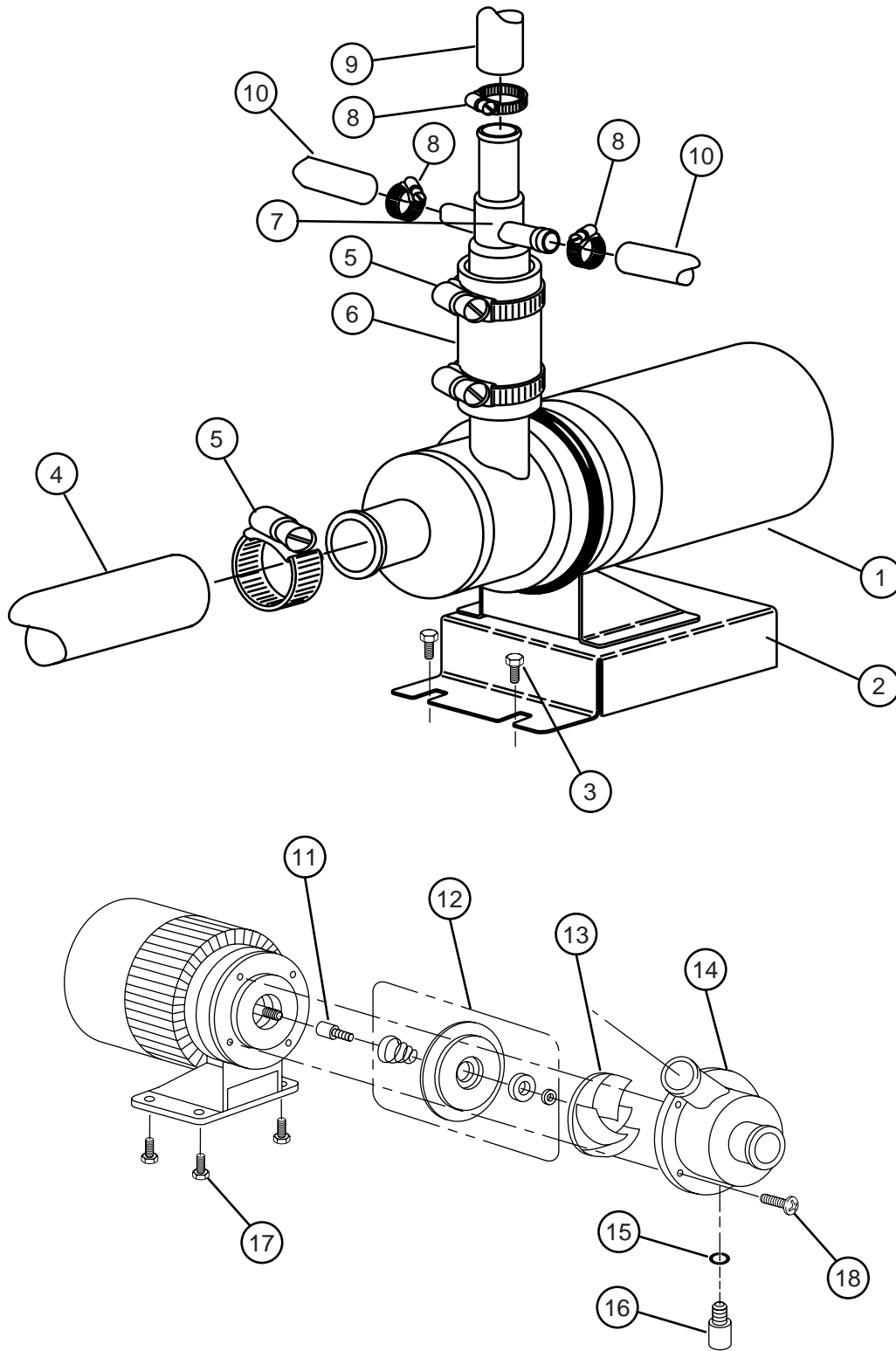

Figure 16 — Wash Pump Assembly

## WASH PUMP ASSEMBLY

<b>Fig. 16 Item No.</b>	<b>Part No.</b>	<b>Part Description</b>	<b>Qty.</b>
1	0507313	Wash Pump Complete .....	1
2	0307410	Wash Pump Base .....	1
3	0501419	1/4-20 x 1/2" Bolt .....	2
4	0507320	1" I.D. X 1-1/4" O.D. PVC Hose.....	AR
5	0502563	1" Gear Clamp.....	4
6	0502668	1" I.D. Braided Hose .....	AR
7	0501632	Pump Hose Connector .....	1
8	0503679	7/16" Gear Clamp .....	2
9	0502665	1/2" I.D. Braided Hose.....	AR
10	0502663	3/8" I.D. Braided Hose.....	AR
11	0502734	Stub Shaft .....	1
12	0502730	Seal Kit c/w Spring .....	AR
13	0502729	Impeller .....	1
14	0502731	Pump Housing.....	1
15	0501635	"O" Ring, 5/16 I.D. X 1/16W .....	1
16	0502732	Housing Seal Screw .....	1
17	0503648	Screw, 8-32 x 5/16" .....	4
18	0501406	Screw, 8-32 x 1/2" .....	4

**NOTE:**

*Motor is not available as a separate item.*

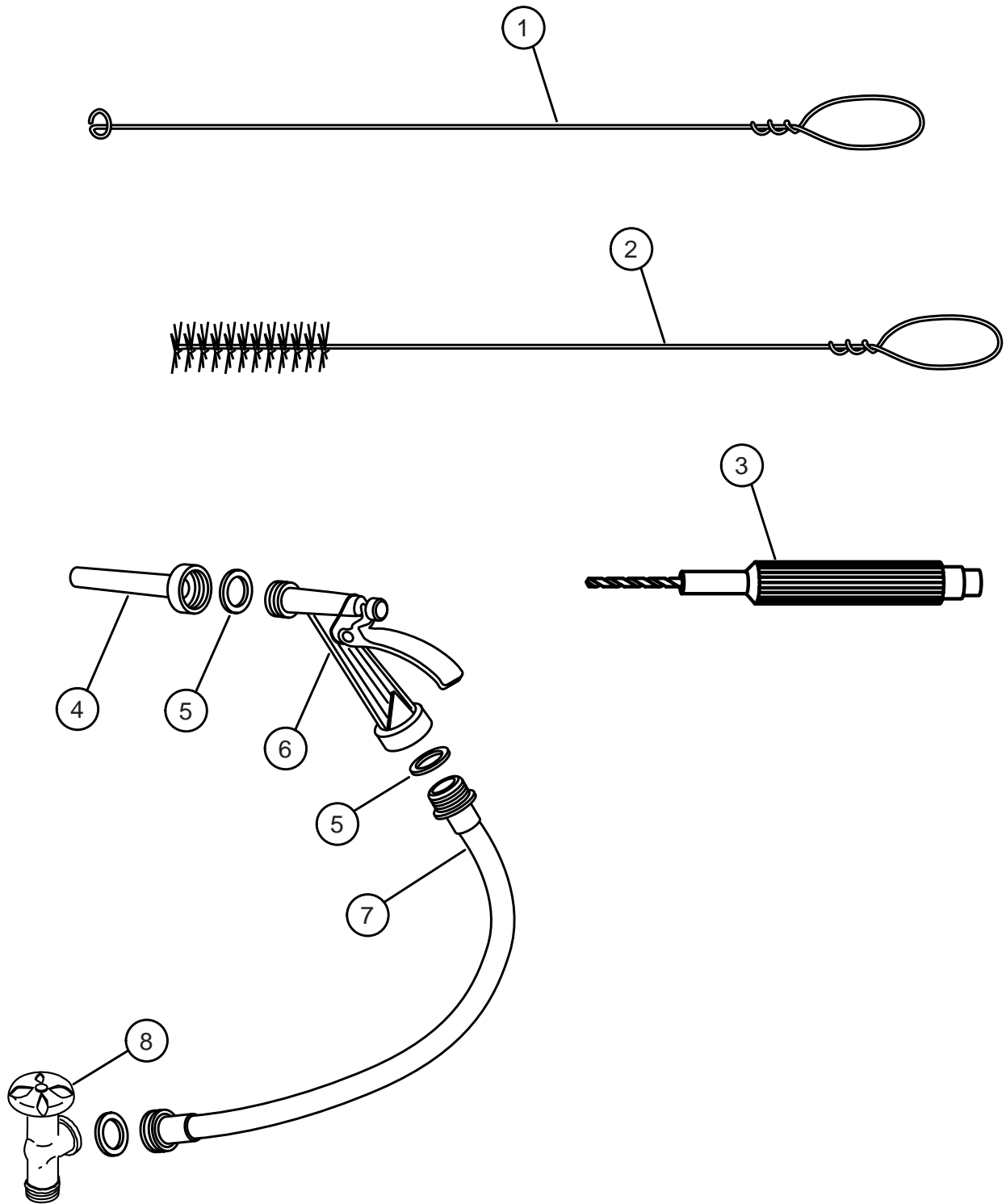

Figure 17 — Cleaning Accessories

**CLEANING ACCESSORIES**

<b>Fig. 17 Item No.</b>	<b>Part No.</b>	<b>Part Description</b>	<b>Qty.</b>
1	0703390	Tube Scraper .....	1
2	0501714	Tube Brush .....	1
3	0501633	Jet Reamer c/w Drill .....	1
4	0703454	Wash Down Nozzle.....	1
5	0505320	1/2" Hose Washer.....	1
6	0502779	Nozzle.....	1
7	0501833	1/2" x 10' Hose Assembly.....	1
8	0506643	Faucet .....	1

**OPTIONAL ACCESSORIES (not shown)**

<b>Fig. 18 Item No.</b>	<b>Part No.</b>	<b>Part Description</b>	<b>Qty.</b>
–	0706204	Drain Tray and Waste Collector	
–	0707258	Quick Disconnect Package (Including Casters)	
–	0501874	Caster, reg.....	2
–	0501876	Caster, locking.....	2
–	0701962	Caster Kit (2 Locking, 2 Regular)	
–	0507255	Hose, 1/2 female quick disconnect, 10'	
–	0507256	Hose, 1/2 male quick disconnect, 16"	
–	0708453	Hand Sink and Wet Waste Receiver (SW46)	
–	0701956	Wash Down Hose (Includes Items 4 - 8)	
–	0702882	Panel, Back CG4	
–	0702886	Panel, Back CG6	

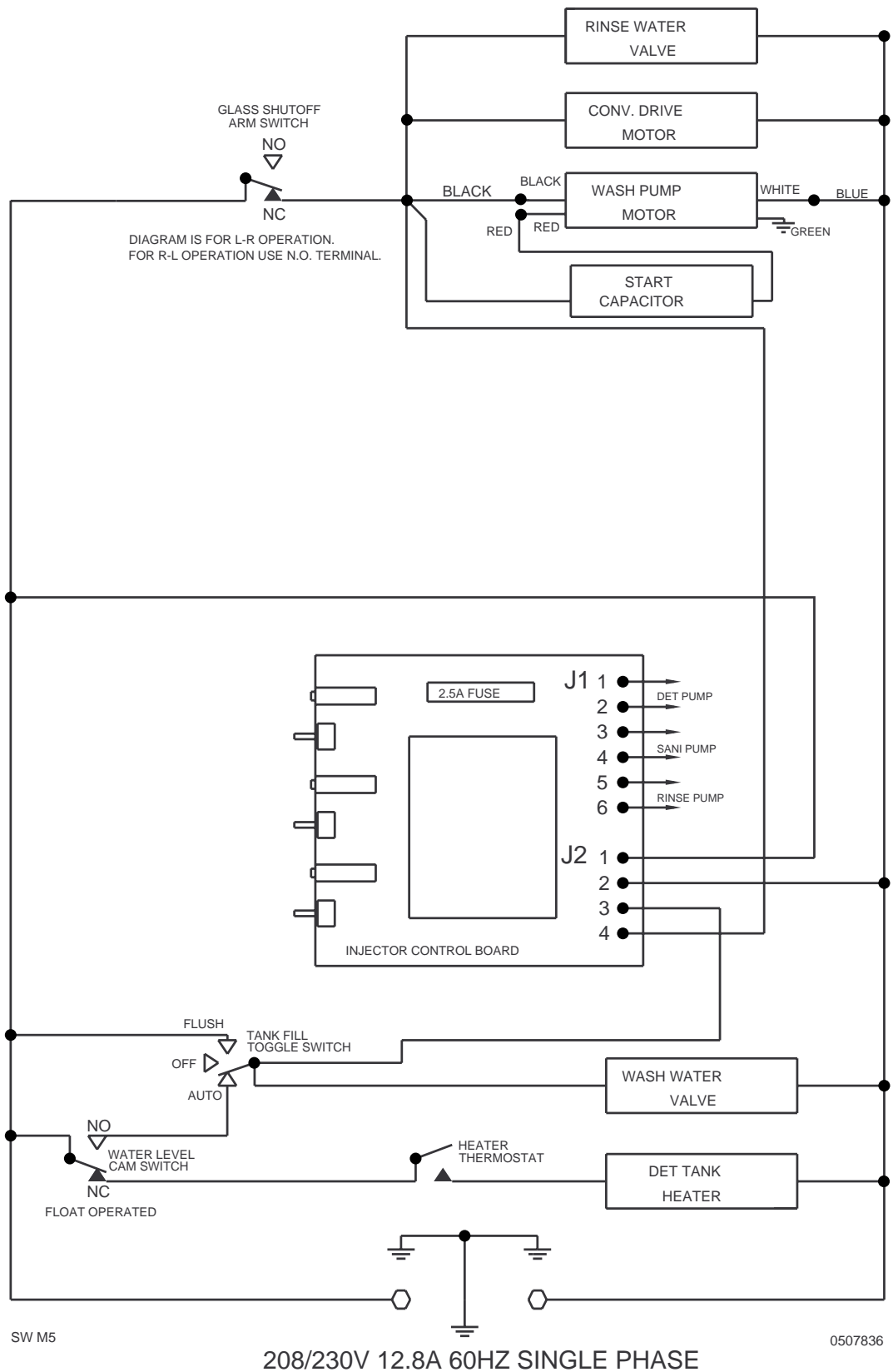
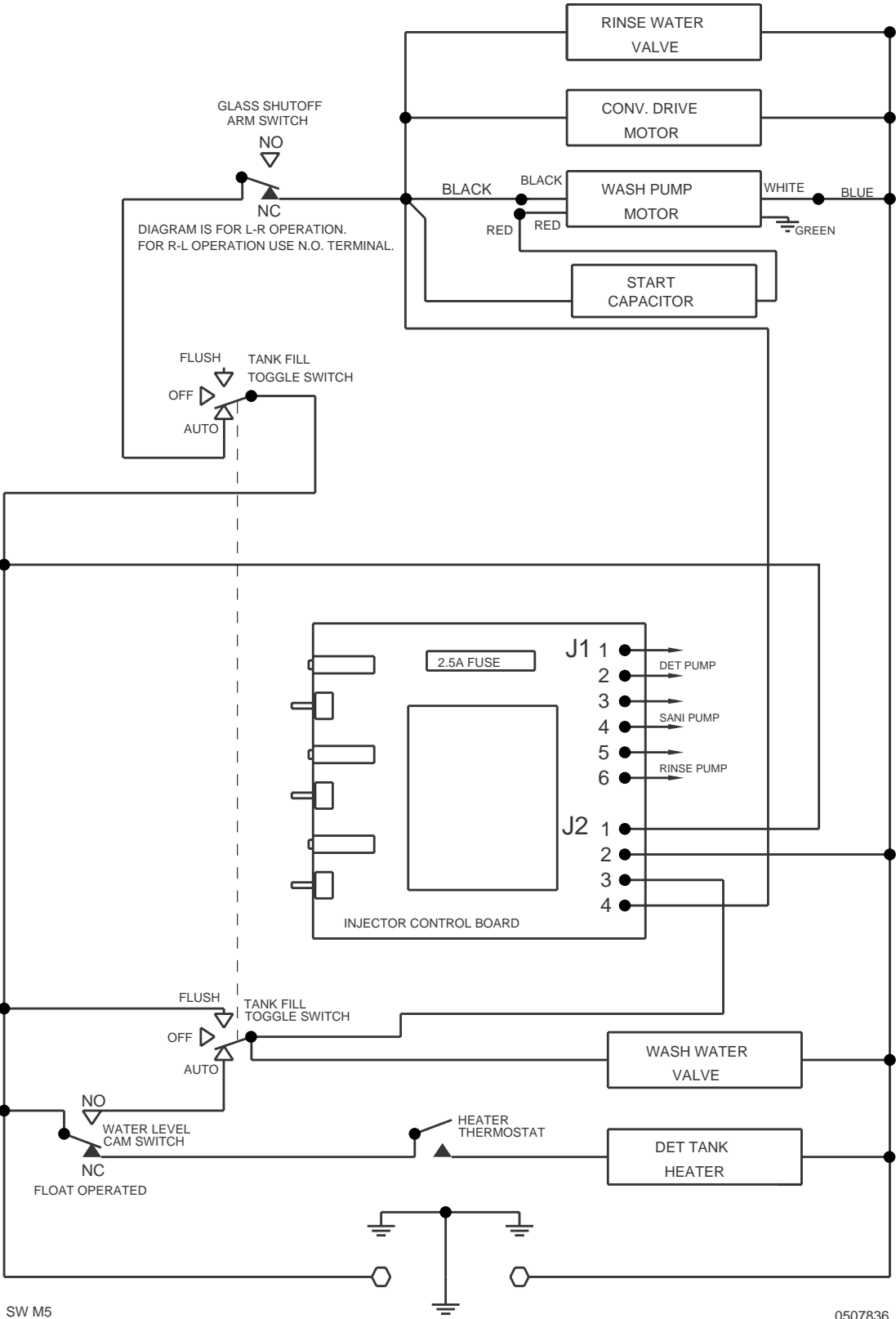

Figure 19 – Electrical Diagram (S/N 5181 through 6105)



SW M5

208/230V 12.8A 60HZ SINGLE PHASE

0507836

Figure 20 – Electrical Diagram (S/N 6106 through 6215)

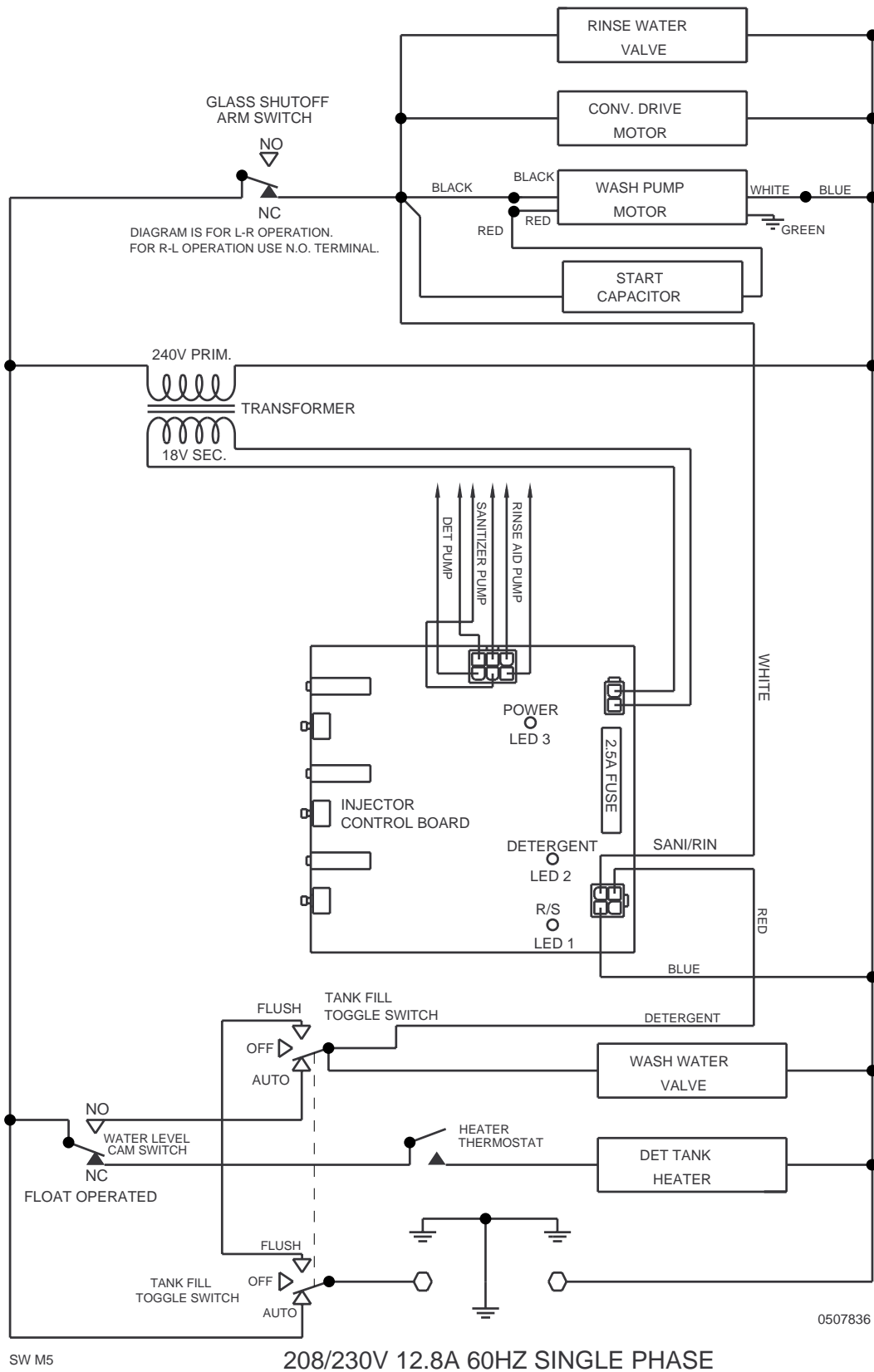

Figure 21 – Electrical Diagram (beginning with S/N 6216)





