

Champion

The Dishwashing Machine Specialists

Technical Manual

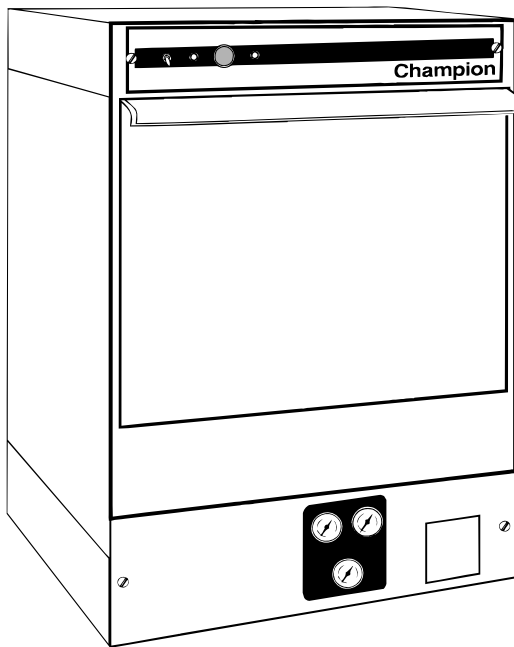

Undercounter Dishwasher

Model

U-HB
High Temperature
with Built-In Booster

U-H1
High Temperature

U-LD
Low Temperature

Machine Serial No.

June, 1995

Manual P/N 111752-1

P.O. Box 4149
Winston-Salem, North Carolina 27115-4149

Champion Industries, Inc.

336/661-1556

Fax: 336/661-1660

Complete the information below so it will be available for quick reference.

Model Number _____ Serial Number _____

Voltage and Phase _____

Champion Parts Distributor _____ Phone _____

Champion Service Agency _____ Phone _____

Champion Industries Service: 1-800-858-4477 Champion Service Fax: 1-336-661-1660

We strongly recommend that you fax your orders.

NOTE: When calling to order parts, be sure to have the model number, serial number, voltage, and phase of your machine.

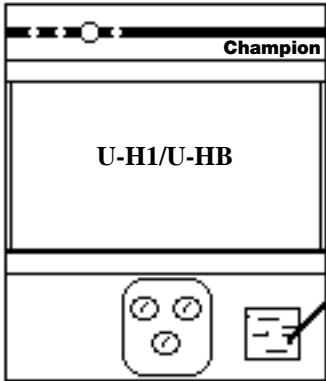

Machine Data Plate with Model & Serial number located on right side of front panel.

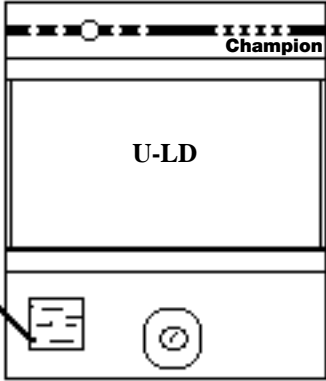

Machine Data Plate with Model & Serial number located on left side of front panel.

Revision History

Revision Date	Revised Pages	Serial Number Effectivity	Comments
12/30/92	—	84299	Air Trap/Pressure Switch changed to Float switch/ Fill Timer for automatic fill and low water protection for Models U-H1/U-HB
1/13/94	—	85680	Relocated final rinse thermometer to back of machine, added brass cross and barb fittings
1/1/95	—		Issued Manual P/N 111752-1 which supercedes Manual P/N 111752 dated May, 1994. For machines beginning with S/N 84299 and above
1/1/95	22	—	Corrected Pump/Motor Removal Instructions (Step 7)
1/1/95	23	—	Added Door Switch and Magnet to illustration
1/1/95	29	—	Corrected Item #16, changed P/N 104741 to P/N 108349
1/1/95	30	—	Added Solenoid Valve detail
1/1/95	33	—	Corrected Item #14, changed P/N 104741 to P/N 108349
1/1/95	34	—	Added Solenoid Valve detail
1/1/95	39	—	Corrected Item #19, changed P/N 110210 to 110211
1/1/95	57	—	Corrected Item #4, changed P/N 108265 to P/N 107550, changed 1/2" to 3/4"
4/10/95	52-53	87075	Redesigned U-HB Booster Tank for machines beginning with S/N 87075 and above
2/9/96	53	87724	Changed control thermostats to P/N 112204

CONTENTS

	Page
The Dishwashing Formula	5
WARRANTY	6
INTRODUCTION.....	7
GENERAL	8
Model Numbers	8
Standard Equipment	8
Options	8
Accessories	9
Electrical Power Requirements	9
INSTALLATION.....	9
Unpacking	9
Electrical Connections.....	10
Plumbing Connections.....	10
Water Connections.....	10
Drain Connections	11
Chemical Connections.....	12
Models U-H1 and U-HB.....	12
Model U-LD.....	12
INITIAL START-UP.....	13
Model U-H1 and U-HB.....	13
Model U-LD	13
OPERATION	14
Model U-H1 and U-HB.....	14
Model U-LD	15
MAINTENANCE.....	16
Maintenance Schedule.....	16
CLEANING	16
Every 2 Hours or After Each Meal Period.....	16
Model U-H1 and U-HB	16
Model U-LD.....	16
Every 8 Hours or at the End of the Day.....	16
Model U-H1 and U-HB	16
Model U-LD.....	17
DELIMING	17
Deliming process	17
Model U-H1 and U-HB	17
Model U-LD.....	18
OPERATION CHECKS.....	18
Daily	18
Weekly	18

CONTENTS

	Page
TROUBLESHOOTING	18
BASIC SERVICE.....	20
Electrical Service.....	20
Motor Connections.....	20
Timed Fill/Low Water Tank Heat Protection.....	20
Mechanical Service.....	21
Timer Cam Adjustments	21
Pump Seal Replacement	22
U-HB Component Diagram	23
REPLACEMENT PARTS LIST	24
ELECTRICAL SCHEMATICS	58
TIMER CHARTS.....	60

LIST OF FIGURES

Figure 1— Drain Connection U-H1/U-HB	11
Figure 2— Drain Connection U-LD	11
Figure 3— U-H1/U-HB Chemical Connection Points	12
Figure 4— Pump Motor Wiring Diagrams U-H1/U-HB/U-LD	20
Figure 5— U-H1/U-HB Timer Chart.....	21
Figure 6— U-LD Timer Chart	21
Figure 7— U-LD Timer Cam Locations	21
Figure 8— Pump Seal Replacement.....	22
Figure 9— Panels and Gauges	24
Figure 10—Door, Tracks, Safety Switch.....	26
Figure 11—U-H1/U-HB Plumbing.....	28
Figure 12—U-H1/U-HB Fill Solenoid Valve and Piping.....	30
Figure 13—U-LD Plumbing	32
Figure 14—U-LD Fill Solenoid Valve and Piping	34
Figure 15—U-LD Chemical Dispensing System	36
Figure 16—U-H1/U-HB Float Switch, Sump, Pump Hoses	38
Figure 17—U-LD Sump, Pump Hoses, Drain Assembly.....	40
Figure 18—U-H1/U-HB Wash Arm Assembly.....	42
Figure 19—U-LD Wash Arm Assembly	44
Figure 20—Pump/Motor Assembly.....	46
Figure 21—U-H1/U-HB Control Cabinet	48
Figure 22—U-LD Control Cabinet.....	50
Figure 23—U-H1/U-HB Thermostats, Booster Assembly, Wash Tank Element.....	52
Figure 24—U-H1/U-HB/U-LD Drain Lift Kits (Optional).....	54
Figure 25—Dishracks, Strainer, PRV	56
Figure 26—U-H1/U-HB Electrical Schematic	58
Figure 27—U-LD Electrical Schematic	59
Figure 28—Timer Charts (U-H1/U-HB) and U-LD.....	60

NOTES

The Dishwashing Formula

Five Elements for Cleaning Dishes

A Perfect Score means **Clean Ware** for your customers...

Peak Dishwasher Performance for you.

	Point Value
1. Temperature	20
Heated water penetrates and loosens soil on dishes.	
2. Time	20
Wash and rinse times (set by NSF and Champion) allow everything to work.	
3. Mechanical Action	20
Pumps produce water pressure which flushes the soil off dishes.	
4. Chemical Action	20
Detergent breaks down grease and loosens soil particles.	
5. Procedure	20
Pre-scraping and rinsing removes large food particles from the dishes.	
SCORE	100

LIMITED WARRANTY

Champion Industries Inc. (herein referred to as Champion), P.O. Box 4149, Winston-Salem, North Carolina 27115, and P.O. Box 301, 2674 N. Service Road, Jordan Station, Canada L0R 1S0, warrants machines, and parts, as set out below.

Warranty of Machines: Champion warrants all new machines of its manufacture bearing the name “Champion” and installed within the United States and Canada to be free from defects in material and workmanship for a period of one (1) year after the date of installation or fifteen (15) months after the date of shipment by Champion, whichever occurs first. [See below for special provisions relating to glasswashers.] The warranty registration card must be returned to Champion within ten (10) days after installation. If warranty card is not returned to Champion within such period, the warranty will expire after one year from the date of shipment.

Champion will not assume any responsibility for extra costs for installation in any area where there are jurisdictional problems with local trades or unions.

If a defect in workmanship or material is found to exist within the warranty period, Champion, at its election, will either repair or replace the defective machine or accept return of the machine for full credit; provided, however, as to glasswashers, Champion’s obligation with respect to labor associated with any repairs shall end (a) 120 days after shipment, or (b) 90 days after installation, whichever occurs first. In the event that Champion elects to repair, the labor and work to be performed in connection with the warranty shall be done during regular working hours by a Champion authorized service technician. Defective parts become the property of Champion. Use of replacement parts not authorized by Champion will relieve Champion of all further liability in connection with its warranty. In no event will Champion’s warranty obligation exceed Champion’s charge for the machine. The following are not covered by Champion’s warranty:

- a. Lighting of gas pilots or burners.
- b. Cleaning of gas lines.
- c. Replacement of fuses or resetting of overload breakers.
- d. Adjustment of thermostats.
- e. Adjustment of clutches.
- f. Opening or closing of utility supply valves or switching of electrical supply current.
- g. Cleaning of valves, strainers, screens, nozzles, or spray pipes.
- h. Performance of regular maintenance and cleaning as outlined in operator’s guide.
- i. Damages resulting from water conditions, accidents, alterations, improper use, abuse, tampering, improper installation, or failure to follow maintenance and operation procedures.
- j. Wear on Pulper cutter blocks, pulse vanes, and auger brush.

Examples of the defects not covered by warranty include, but are not limited to: (1) Damage to the exterior or interior finish as a result of the above, (2) Use with utility service other than that designated on the rating plate, (3) Improper connection to utility service, (4) Inadequate or excessive water pressure, (5) Corrosion from chemicals dispensed in excess of recommended concentrations, (6) Failure of electrical components due to connection of chemical dispensing equipment installed by others, (7) Leaks or damage resulting from such leaks caused by the installer, including those at machine table connections or by connection of chemical dispensing equipment installed by others, (8) Failure to comply with local building codes, (9) Damage caused by labor dispute.

Warranty of Parts: Champion warrants all new machine parts produced or authorized by Champion to be free from defects in material and workmanship for a period of 90 days from date of invoice. If any defect in material and workmanship is found to exist within the warranty period Champion will replace the defective part without charge.

DISCLAIMER OF WARRANTIES AND LIMITATIONS OF LIABILITY. CHAMPION’S WARRANTY IS ONLY TO THE EXTENT REFLECTED ABOVE. CHAMPION MAKES NO OTHER WARRANTIES, EXPRESS OR IMPLIED, INCLUDING, BUT NOT LIMITED, TO ANY WARRANTY OF MERCHANTABILITY, OR FITNESS OF PURPOSE. CHAMPION SHALL NOT BE LIABLE FOR INCIDENTAL OR CONSEQUENTIAL DAMAGES. THE REMEDIES SET OUT ABOVE ARE THE EXCLUSIVE REMEDIES FOR ANY DEFECTS FOUND TO EXIST IN CHAMPION DISHWASHING MACHINES AND CHAMPION PARTS, AND ALL OTHER REMEDIES ARE EXCLUDED, INCLUDING ANY LIABILITY FOR INCIDENTALS OR CONSEQUENTIAL DAMAGES.

Champion does not authorize any other person, including persons who deal in Champion dishwashing machines to change this warranty or create any other obligation in connection with Champion Dishwashing Machines.

INTRODUCTION

Welcome to **Champion...**

and thank you for allowing us to take care of your dishwashing needs.

This manual covers the undercounter series dishwasher models U-H1, U-HB, and U-LD. Your machine was completely assembled, inspected, and thoroughly tested at our factory before it was shipped to your installation site.

This manual contains:

- Warranty Information
- Operation and Cleaning Instructions
- Maintenance Instructions
- Troubleshooting Guide
- Basic Service Information
- Replacement Parts Lists
- Electrical Schematics

Complete and return your warranty registration card within ten (10) days after the installation of your machine.

All information, illustrations and specifications contained in this manual are based upon the latest product information available at the time of publication. **Champion** constantly improves its products and reserves the right to make changes at any time or to change specifications or design without notice and without incurring obligation.

For your protection, factory authorized parts should always be used for repairs.

Replacement parts may be ordered directly from **Champion Industries*** or from your **Champion** authorized parts distributor or authorized service agency. When ordering parts, please supply the model number, serial number, voltage, and phase of your machine, the part number, part description and quantity.

***Champion Industries** can only ship parts to customers by C.O.D.

GENERAL

This manual covers the Champion undercounter dishwashing machine. These machines are fully automatic and come equipped with a 3/4 HP pump motor. All models are available for mounting directly to the floor or on optional stands.

The U-series dishwasher is available in the following models:

Model Numbers

U-H1, U-HB, U-LD

The U-H1 model is a high temperature (82°C/180°F rinse) sanitizing model without booster.

The U-HB model is a high temperature (82°C/180°F rinse) sanitizing model with booster.

The U-LD is a low temperature (Min. 49°C/120°F-60°C/140°F Optimum) sanitizing model for use with a sodium hypochlorite (Chlorine) based sanitizer at a minimum concentration of 50PPM in the final rinse. A three pump chemical dispensing system for detergent, sanitizer and rinse aid is included.

Standard Equipment includes:

U-H1 & U-HB

- Top mounted slide-out control cabinet
- Common utility connections
- Fully automatic wash & rinse cycle
- Self-sealing gasketless door
- Door safety switch
- Upper & lower wash/rinse arms
- 90 second time cycle
- Electric tank heater
- Low water tank heat protection
- 3/4HP (208-240V/60/1) wash motor
- Stainless steel heavy gauge construction, including base
- Two dish racks (peg and flat bottom)
- Built-in electric booster heater (U-HB Only) (4°C/40°F temperature rise)
- 1-1/4" I.D. GRAVITY drain connection

U-LD

- Top mounted slide-out control cabinet
- Common utility connections
- Fully automatic wash & rinse cycle
- Self-sealing gasketless door
- Door safety switch
- Upper & lower wash/rinse arms
- 150 second time cycle
- Three built-in chemical dispensing pumps
- 3/4HP (115V/60/1) wash motor
- Stainless steel heavy gauge construction, including base
- Two dish racks (peg and flat bottom)
- 1-1/4" I.D. GRAVITY drain connection

Options

Electric booster (21°C/70°F temperature rise) heater for 43°C/110°F supply water (U-HB only) N/A

Pumped drain lift-out Kit (U-H1 and U-HB) P/N 403898

Drain lift kit (U-LD) P/N 403801

P-Trap (U-H1 and U-HB) P/N 403836

Unmounted Pressure Regulating Valve (3/4" PRV) P/N 107550

1-1/4" flexible drain hose (order by the foot) P/N 111032

Accessories

Combination 1-RDT table w/ cabinet and sink (specify right hand or left hand sink)

Optional sprayhose for 1-RDT	P/N 100243
Wall overshelf for 1-RDT (holds two racks)	P/N 108189
16" Stainless steel stand	P/N 305222
6" Stainless steel leg set (Qty.4)	P/N 305221
Additional dishracks:	
Dish rack (peg)	P/N 101285
Silverware rack (flat bottom)	P/N 101273

Electrical Power Requirements

Model	Voltage	Booster Rise (U-HB Only)	Machine Full Load Amps	Power Requirement (125% Service Factor)
U-H1	208/60/1	—	12 Amps	15 Amps
U-H1	220/60/1	—	11 Amps	14 Amps
U-H1	230/60/1	—	11 Amps	14 Amps
U-H1	240/60/1	—	11 Amps	14 Amps
U-HB	208/60/1	40°F	44 Amps	55 Amps
U-HB	220/60/1	40°F	44 Amps	55 Amps
U-HB	230/60/1	40°F	46 Amps	58 Amps
U-HB	240/60/1	40°F	48 Amps	60 Amps
U-HB	208/60/1	70°F	58 Amps	73 Amps
U-HB	220/60/1	70°F	60 Amps	75 Amps
U-HB	230/60/1	70°F	62 Amps	76 Amps
U-HB	240/60/1	70°F	64 Amps	80 Amps
U-LD	115/60/1	—	12 Amps	15 Amps

INSTALLATION

Unpacking



CAUTION:

Care should be taken when lifting the machine to prevent damage.

1. Immediately after unpacking the machine, inspect for any shipping damage. If damage is found, save the packing material and contact the carrier immediately.
2. Remove the dishwasher from the skid. Adjust the feet if required, then move the machine to its permanent location.
3. Level the machine (if required) by placing a level on the top of machine and adjusting the feet. Level the machine front-to-back and side-to-side.
4. Remove the two dishracks from the interior of the machine.
5. Remove the lower access panel in preparation for service connections.

INSTALLATION (Cont.d)



NOTE:

The installation of your machine must meet local health codes.

Some locales may require the base of the machine to be sealed at the floor.

Electrical Connections



WARNING:

Electrical and grounding connections must comply with the National Electrical Code and/or Local Electrical Codes.



WARNING:

When working on the dishwasher, disconnect the electric service and place a tag at the disconnect switch to indicate work is being done on that circuit.

1. A qualified electrician must compare the electrical power supply with the machine electrical specifications stamped on the MACHINE ELECTRICAL CONNECTION PLATE located inside the top mounted control cabinet before connecting to the incoming service at a fused disconnect switch.

NOTE:

*U-H1 and U-HB models require a 208-240V/60Hz/1PH, 2-wire plus ground electrical supply.
U-LD model requires a 115V/60Hz/1PH, 2-wire plus ground electrical supply.*

2. A knock-out is provided at the rear of the top mounted slide-out control cabinet for the electrical service connection. A fused disconnect switch or circuit breaker (supplied by others) is required to protect each power supply circuit.

NOTE:

INSTALLER SHOULD PROVIDE SUFFICIENT CABLE TO ALLOW TOP MOUNTED SLIDE-OUT CONTROL CABINET TO EXTEND FULLY.

Plumbing Connections



CAUTION:

Plumbing connections must comply with local sanitary and plumbing codes.

Water Connections

1. HOT WATER connection can be made to the machine via the 6 foot reinforced fill hose supplied with the machine. The fill hose is equipped with a 3/4" NPT connector and exits the back of the machine.
2. Minimum incoming water supply temperature requirements are listed below
 - U-HB with built-in 40° rise electric booster (Minimum 60°C/140°F)
(Min./Max. flow pressure 138 kPa/20-22 PSI)
 - U-HB with built-in 70° rise electric booster (Minimum 43°C/110°F)
(Min./Max. flow pressure 138 kPa/20-22 PSI)

Water Connections (Cont.d)

U-H1 without built-in booster (Minimum 70°C/180°F)
(Min./Max. flow pressure 138 kPa/20-22 PSI)

U-LD (Minimum 49°C/120°F - 60°C/140°F Optimum)
(Min./Max. flow pressure 138 kPa/20-22 PSI)

3. A manual shut-off valve (supplied by others) should be installed in supply line to allow for servicing of the machine. The shut-off valve should be the same size or larger than the supply line.
4. A “Y” line strainer (supplied by others) is recommended on the incoming water supply line as close to machine as possible, but before the pressure regulating valve.
5. A 3/4” Pressure Regulating Valve (PRV), (supplied by others), should be installed on the incoming water supply line if water flow pressure exceeds 138 kPa/20-22 PSI.

Drain Connections

1. Models U-H1, U-HB, and U-LD are GRAVITY DRAIN machines equipped with a 1-1/4” hose connection point.
 - Drain height for models U-H1 and U-HB must not exceed 4-1/2” above floor level.
 - Drain height for model U-LD must not exceed 7-1/2” above floor level.

NOTE:

For drain heights in excess of those listed above, OPTIONAL drain lift kits are available (See Options, Pg.8)



WARNING:

Connection of the machine to a drain line higher than the machine drain height will prevent the machine from draining properly.

Refer to Figure 1 and 2 below for machine drain connection locations.

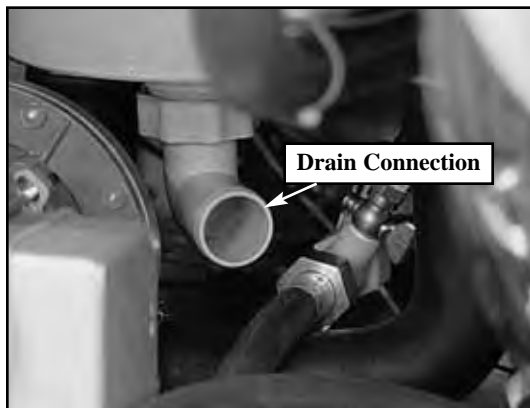

Figure 1
1-1/4” Drain Connection
U-H1/U-HB
Rear View of Machine

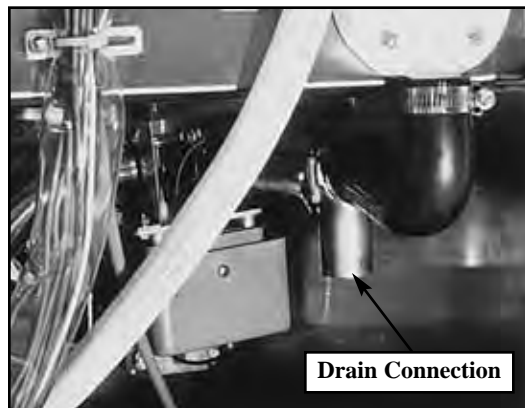

Figure 2
1-1/4” Drain Connection
U-LD
Rear View of Machine

Chemical Connections



NOTE:

Consult a qualified chemical supplier for your chemical needs.

Models U-H1 and U-HB

1. Labeled connection points (See Fig. 3) are provided inside the control cabinet for chemical dispensing equipment (supplied by others).

Connection points include:

- Detergent signal 208-240VAC between Wire #7 and Wire #2 . (1 Amp Max Amperage Draw)
- Rinse aid signal 208-240VAC between Wire #8 and Wire #2 (1 Amp Max Amperage Draw)

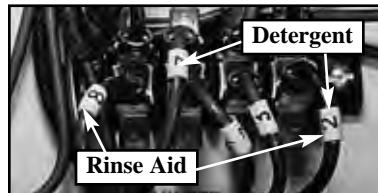

Figure 3
U-H1/U-HB Chemical Connection Points

2. Detergent injection point and location of conductivity cell must be provided by a qualified chemical supplier.
3. Detergent may be added manually for U-H1/U-HB models not equipped with dispensing systems. Consult your local chemical supplier for the correct amount of non-chlorinated automatic dishwashing liquid detergent.
4. U-H1 and U-HB models do not require chemical sanitizing agents.
5. Rinse aid injection point is provided via a 1/2” NPT plug located in the fill manifold piping. The manifold is located after the fill solenoid valve on the center right side of the machine base behind the gauges.

Model U-LD

1. Equipped with three built-in dispensing pumps for detergent, sanitizer, and rinse aid. Pump Priming switches are located on the front of the control cabinet. (See U-LD Initial Start-up for pump priming instructions, (Pg. 13, Step 10). (See U-LD Service for timer cam settings and adjustments, (Pg. 21)
2. Chemical pick-up tubes are color coded.
 - Red = detergent Blue = Rinse aid Clear = Sanitizer
 Chemicals are supplied by others.
3. Use an automatic commercial grade liquid detergent. Use a sodium hypochlorite (Chlorine) based sanitizer at a minimum concentration of 50PPM in the final rinse. Use chlorine test papers to verify and monitor the 50PPM chlorine level.
4. Use a liquid rinse aid.



WARNING:

Never premix rinse aid with the sanitizing agent. Mixing may cause hazardous gases to form.



CAUTION:

Some metal, including silver, aluminum, and pewter are attacked by sodium hypochlorite (chlorine sanitizer). Avoid cleaning these metals in a U-LD dishwasher.

INITIAL START-UP

After plumbing and electrical connections are completed, follow the steps below to place your machine in service.

Model U-H1 and U-HB

1. Remove any foreign material from inside the machine. Make sure filter, and drain-overflow tube are in place.
2. Close the Door.
3. Turn the water and main power sources to the dishwasher ON.
4. Flip the Power switch to the ON position. The red “power on” light will illuminate and the machine will automatically fill with water.
5. Check the machine for leaks.
6. Push the Green Start Button to check automatic cycle. Check for leaks.
7. If machine checks okay, remove the drain-overflow tube to drain machine.
8. Flip the power switch to OFF.

Model U-LD

1. Remove any foreign material from inside the machine. Make sure filter, is in place.
2. Close the Door.
3. Turn the water and main power sources to the dishwasher ON.
4. Flip the Power switch to the ON position. The red “power on” light will illuminate.
5. Hold the Fill switch in the “UP” position for about 45 sec. to fill the machine with water. Machine is full when water level reaches drain overflow located at lower left rear corner of wash tank interior.
6. Check the machine for leaks.
7. Prime the chemical dispensing pumps.



NOTE:

*The pick-up tubes are color coded:
Red = detergent Blue = rinse aid Clear = sanitizer*

8. Insert the pick-up tubes in the appropriate chemical containers.
9. Open the door of the machine.
10. Hold each of the three prime switches, located on the front of the control cabinet in the “UP” position until you see chemical enter the tank interior from all three tubes.



NOTE:

The chemical tubes discharge point is on the right side of the wash tank ceiling.

11. The chemical dispensing system will work automatically until the chemical supply is used up. Re-prime the dispensing pump after replacing a chemical container.
12. Close the door.
13. Push the the Green start button to check the automatic cycle. Check for leaks.
14. If machine checks okay, hold the drain switch in the “UP” position until machine drains completely.
15. Flip the power switch to OFF.

OPERATION

Model U-H1 and U-HB

- | | | |
|----|---|---|
| 1. | Close the door and flip power switch ON | Red power light illuminates.
Tank fills automatically and tank heat comes on |
| 2. | Monitor wash tank temperature gauge | Wait for temperature reading to reach
Minimum 66°C/150°F |
| 3. | Prescrap and load ware into rack | Place dishes edgewise in peg rack,
Cups and bowls upside down in flat rack,
Silverware spread evenly in single layer
in flat rack |
| 4. | Open door , insert rack | |
| 5. | Close door, Push Green start button | Green cycle light will illuminate
Automatic cycle begins.

Machine washes for 67 sec., then
pauses for 2 sec |
| 6. | During final Rinse
Monitor pressure gauge and
final rinse temperature gauge | Machine final rinses for 21 sec.
Pressure gauge reading must read
between 20-22 PSI
Temperature gauge must read
82-91°C/180-195°F |
| 7. | 90 second cycle complete | Green cycle light goes out |
| 8. | Open door, remove clean rack | Insert another rack of soiled ware |
| 9. | After each meal period or
every two hours operation | Remove drain-overflow tube and drain
machine. Flush interior and clean sump
filter and pump intake strainer. Check
spray arms and clean if necessary |



NOTE:

Opening the door at any time during the cycle will stop the machine.

Closing the door and pushing the Green start button will resume the cycle where it left off.

Model U-LD

- | | | |
|-----|---|--|
| 1. | Close the door and flip power switch ON | Red power light illuminates |
| 2. | Hold the Fill switch in “UP” position for about 45 sec. | Wash tank fills with water |
| 3. | Monitor wash tank temperature gauge | Temperature reading must be Min. 120°F/140°F Optimum |
| 4. | Prescrap and load ware into rack | Place dishes edgewise in peg rack, Cups and bowls upside down in flat rack, Silverware spread evenly in single layer in flat rack |
| 5. | Open door , insert rack | |
| 6. | Close door, Push Green start button | Green cycle light will illuminate Automatic cycle begins.

Machine washes for 62 sec., then Drains and refills for 56 sec. |
| 7. | Monitor temperature gauge

If wash temperature drops below 120°F, Drain and refill machine. | Machine final rinses for 32 sec. Temperature gauge must read a (Minimum 120°-140° F Optimum) |
| 8. | 150 second cycle complete | Green cycle light goes out |
| 9. | Open door, remove clean rack | Insert another rack of soiled ware |
| 10. | After each meal period or every two hours operation | Hold drain switch in “UP position and drain machine. Flush interior and clean filter and strainer plate. Drain again. Check spray arms and clean if necessary. |

**NOTE:**

Opening the door at any time during the cycle will stop the machine.

Closing the door and pushing the Green start button will resume the cycle where it left off.

MAINTENANCE

Cleaning your machine is the best maintenance that you can provide. Components that are not regularly flushed and cleaned do not perform well.

The Maintenance intervals shown in the following schedules are the minimum requirements necessary for the proper performance of your machine. Maintenance intervals should be shortened whenever your machine is faced with abnormal working conditions, hard water, or multiple shift operations.

Maintenance Schedule

CLEANING

• Every 2 Hours or After Each Meal Period

Model U-H1 and U-HB

1. Flip the power switch OFF.
2. Remove the drain-overflow tube, drain the machine.
3. Flush tank interior with fresh water.
4. Remove and clean the sump filter and pump intake screen.
5. Inspect the spray arm nozzles and clean if necessary.
6. Close door, flip power switch ON to refill machine.

Model U-LD

1. Hold drain switch in “UP” position until tank drains completely.
2. Flip power switch to OFF.
3. Flush tank interior with fresh water.
4. Drain machine again.
5. Remove and clean the sump filter and strainer plate.
6. Inspect the spray arm nozzles and clean if necessary.
7. Close door, flip power switch ON.
8. Hold fill switch in “UP” position to refill machine.

• Every 8 Hours or at the End of the Day

Model U-H1 and U-HB

1. Flip the power switch OFF.
2. Remove the drain-overflow tube, drain the machine.
3. Flush tank interior with fresh water.
4. Remove the sump filter and pump strainer.
5. Remove the spray arms.
6. Clean and inspect the spray arm bearings.
7. Remove the spray arm end plugs by twisting counter-clockwise and pulling.
8. Flush the spray arm pipes and nozzles.
9. Replace the end plugs.
10. Back flush the sump filter and pump intake strainer.
11. Thoroughly clean the exterior of the machine. **DO NOT HOSE DOWN WITH WATER.**
12. Reassemble the machine. Leave the door open to aid overnight drying.



CAUTION:

DO NOT LEAVE WATER IN WASH TANK OVERNIGHT

Cleaning (Cont.d)

Model U-LD

1. Hold drain switch in "UP" position until tank drains completely.
2. Flip power switch to OFF.
3. Flush tank interior with fresh water.
4. Remove the sump filter and strainer plate.
5. Remove the spray arms.
6. Clean and inspect the spray arm bearings.
7. Remove the spray arm end plugs by twisting counter-clockwise and pulling.
8. Flush the spray arm pipes and nozzles.
9. Replace the end plugs.
10. Back flush the sump filter and strainer plate
11. Thoroughly clean the exterior of the machine. **DO NOT HOSE DOWN WITH WATER.**
12. Reassemble the machine. Leave the door open to aid overnight drying.



CAUTION:

DO NOT LEAVE WATER IN WASH TANK OVERNIGHT

DELIMING

Your dishwasher should be delimed regularly depending on the mineral content of your water. Inspect the machine interior for mineral deposits and use a deliming solution for the best cleaning results.



NOTE:

Consult your chemical supplier for an appropriate deliming solution.



WARNING:

Deliming solutions or other acids must not come in contact with household bleach (sodium hypochlorite) or any chemicals containing chlorine, iodine, bromine, or fluorine. Mixing will cause hazardous gases to form. Skin contact with deliming solutions can cause severe irritation and possible chemical burns. Consult your chemical supplier for specific safety precautions.

DELIMING PROCESS

Model U-H1 and U-HB (Not equipped with chemical dispensing system)

1. Remove all dishes from machine.
2. Drain the machine and refill with fresh water.
3. Spray interior walls with delimiting solution and let sit for 5 or 10 minutes depending on amount of build-up. Add delimiting solution to wash tank. Do not let chemicals sit for longer than 15 minutes.
4. Push the Green start button and run an automatic cycle.
5. Repeat Step 3-4 if necessary.
6. Remove the drain-overflow tube and drain the machine.
7. Refill the machine and run a complete cycle two additional times. Drain and refill the machine after each cycle to thoroughly flush any delimiting solution from the interior of the machine.
8. Flip the power switch to OFF.
9. Drain Machine.
10. Delimiting is complete.

DeLiming Process (Cont.d)

Model U-LD

1. Remove all dishes from machine.
2. Remove the chemical pick-up tubes from their containers.
3. Place each tube in a container of fresh water and hold each prime switch in the “UP” position several minutes to thoroughly flush chemical from the lines. Leave pick-up tubes out of their containers.
4. Hold the drain switch in the “UP” position to drain the machine.
5. Refill the machine with fresh water and drain again. Then refill with water.
6. Spray interior walls with deliming solution and let sit for 5 or 10 minutes depending on amount of build-up. Add deliming solution to wash tank.
Do not let chemicals sit for longer than 15 minutes.
7. Push the Green start button and run an automatic cycle.
8. Repeat Step 3-6 if necessary.
9. Hold the drain switch in the “UP” position to drain the machine.
10. Refill the machine and run a complete cycle two additional times.
Drain and refill the machine after each cycle to thoroughly flush any deliming solution from the interior of the machine.
11. Replace the pick-up tubes in their chemical supplies and reprime the system.
12. Flip the power switch to OFF.
13. Deliming is complete.

OPERATION CHECKS

• Daily

1. Check temperature gauges for proper readings.
2. Check pressure gauge for proper reading (U-H1, U-HB ONLY).
3. Check for leaks.
4. Check chemical supplies and refill as necessary.

• Weekly

1. Inspect all water lines for leaks.
2. Clean all detergent residue from the exterior of the machine.
3. Check the drains for leaks.
4. Clean accumulated mineral deposits from the tank heating elements (U-H1, U-HB ONLY)
5. Check that float switch moves freely (U-H1,U-HB ONLY).
6. Check and clean chemical dispensing system (U-LD ONLY).

TROUBLESHOOTING

On occasion your machine may not operate as expected.

Use the checklist below before you decide that a mechanical or electrical failure has occurred.

Checklist

1. All switches are ON?
2. Water supply ON?
3. Drain-overflow tube in place? (U-H1 and U-HB Only)
4. Spray arms and nozzles clean?
5. Spray arm end plugs in place?
6. Sump filter, pump strainer clean?
7. Thermostats set correctly? (U-H1, U-HB Only)
8. Door fully closed?
9. Chemical supplies filled?

If a problem still exists after verifying the checklist, refer to the following Troubleshooting Chart.

CONDITION	CAUSE	SOLUTION
Machine will not start	-Door not closed.....	Close door fully
	-Main switch OFF.....	Check breakers or fuses
Low or no water	-Main water supply OFF.....	Turn on house water supply
	-PRV misadjusted or defective	Set PRV to 138 kPa/20-22 PSI flowing pressure Replace PRV
	-Line strainer clogged.....	Clean line strainer
Water temperature low when in use	-Incoming water temperature at machine too low	Raise temperature to: 70°C/180°F for U-H1 60°C/140°F for U-HB 40°F rise booster 43°C/110°F for U-HB 70°F rise booster 60°C/Min 120°F-(140°F Optimum) for U-LD
	-U-LD machine left idle for extended period	Drain and refill with fresh hot water (Optimum temperature 140°F)
	-Thermostats out of adjustment/defective (U-H1/U-HB Only)	Readjust or replace thermostats
Insufficient pumped spray pressure	-Clogged spray arms	Clean spray arms and nozzles
	-Sump filter clogged.....	Must be kept clean and in place
Low final rinse temperature	-Low incoming water	See Solution for (Water temperature low when in use)
	-U-LD set idle	Drain and refill with fresh hot water
	-Thermostat misadjusted or defective (U-HB Only)	Adjust or replace booster thermostat (U-HB Only)
Chemical not feeding (U-LD Only)	-No chemical in container	Replace or refill container
	-Feed tubes to/from chemical pump clogged	Clean obstruction and flush with hot water
	-Tubing kinked or split.....	Straighten or replace tubing
Poor washing results	-Chemical pump defective	Contact your service agent
	-Insufficient detergent	Check and fill supply
	-Detergent setting low	Contact chemical supplier
	-Wash water temperature too low	See water temperatures above
	-Wash arm clogged	Clean wash arm
	-Improperly scraped dishes	Check scraping procedures
	-Ware improperly placed in rack	Use proper racks. Do not overload racks.
	-Improperly cleaned machine	Check cleaning schedules
	-Electric element has soil/lime build-up (U-HB, U-H1 Only)	Clean and/or delime

BASIC SERVICE

This Basic Service section does not cover all possible repair procedures. If you require additional service support, you may call:

Champion National Service
1-800-858-4477

Please have the Model and Serial Number of the machine ready when you call.

Electrical Service



NOTE:

DO NOT USE CHASSIS GROUND WHEN PERFORMING VOLTAGE CHECKS.

Doing so will result in false and inaccurate readings.

PERFORM VOLTAGE CHECKS BY READING FROM THE HOT SIDE OF THE LINE AND ANY #2 WIRE or white wire.



WARNING:

USE EXTREME CAUTION when performing tests on energized circuits.



WARNING:

When repairing a circuit, disconnect the power at the main service disconnect switch and place a tag at the disconnect switch to indicate that work is being performed on the circuit.

Motor Connections

Model U-H1 and U-HB use a 208-240V/60Hz/1Ph capacitor start pump motor.

Model U-LD uses a 115V/60Hz/1Ph capacitor start pump motor.

Refer to Fig.4 for the proper wiring of the pump motor and capacitor.

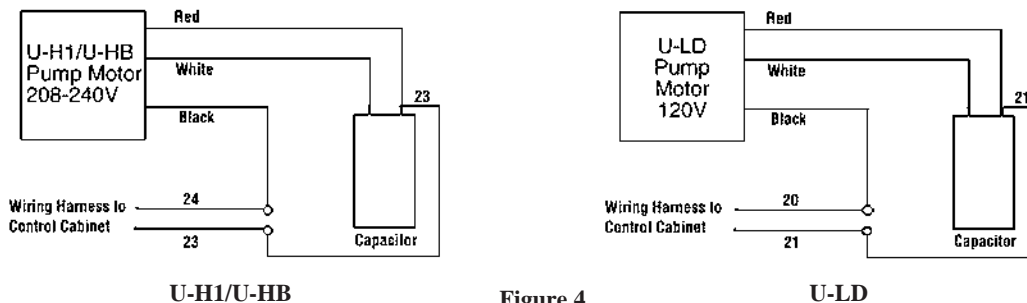

Figure 4
Pump Motor Wiring Diagrams

Timed Fill/Low Water Tank heat Protection

Models U-H1, U-HB use a float switch and fill timer to control tank fill and tank heat.

Model U-HB built-in booster heater is also controlled by the float switch.

Operation:

1. When power switch is turned on, fill timer runs for a minimum of 90 seconds to fill the tank.
2. Float switch ball rises and allows tank heat and booster heat to energize.
3. If water level drops too low, float switch ball moves down; heat de-energizes and the fill timer runs for a minimum of 90 seconds to refill the tank.

MECHANICAL SERVICE

Timer Cam Adjustments

Model U-H1 and U-HB cycle timers are set at the factory and are not adjustable. See Timer Chart (Fig. 5) for the U-H1/U-HB timer cam settings.

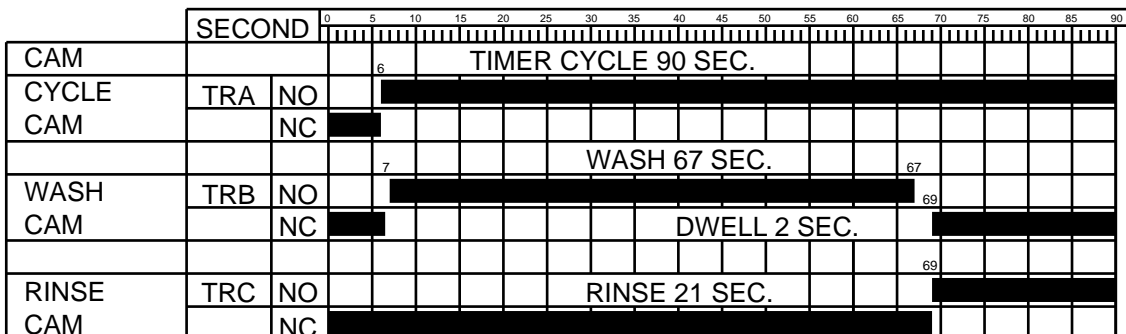

Figure 5 - U-H1/U-HB Timer Chart

Model U-LD cycle timers are adjustable for fill, detergent, rinse aid, and sanitizer times. The timers are adjusted at the factory before shipment (See Fig.6).

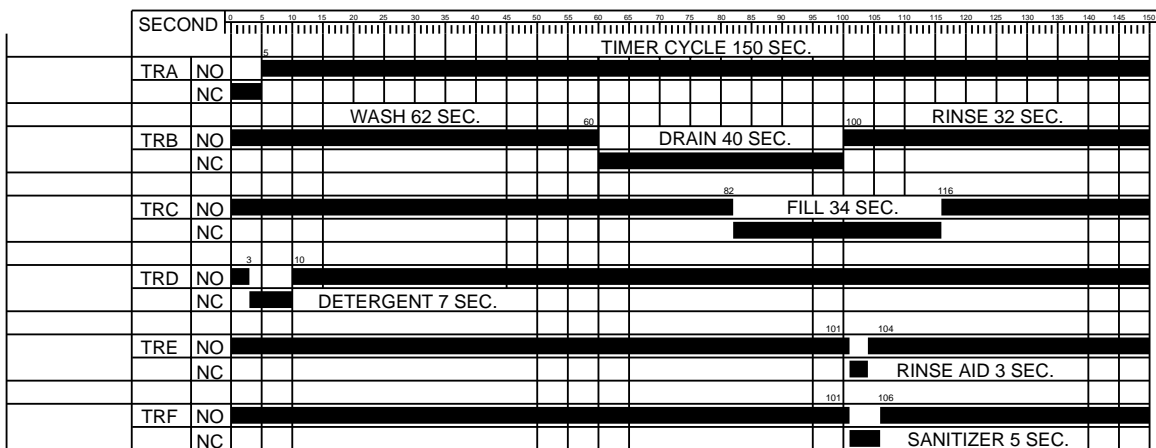

Figure 6 - U-LD Timer Chart

To adjust Model U-LD timer cams:

1. Locate the adjustment tool located near the timer in the control cabinet.
2. Adjust the LEFT HAND side of the cam ONLY.
3. Lock the adjustment tool in the LH side of the cam to be adjusted.
4. TO INCREASE the operating time, hold the RH side of cam stationary while rotating the LH side of cam toward the rear of the control cabinet.
5. TO DECREASE the operating time, hold the RH side of cam stationary while rotating the LH side of the cam toward the front of the control cabinet.

(See Fig. 7 for the U-LD cam locations)

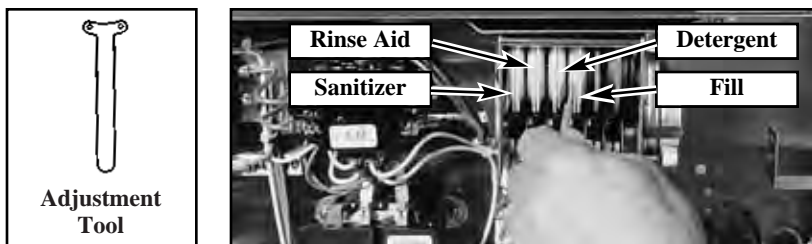

Figure 7 - U-LD Timer Cam Locations

MECHANICAL SERVICE (Cont.d)

Pump Seal Replacement

1. Disconnect the power to the machine at the main breaker panel or fuse box.
2. Drain the machine.
3. Remove the guage bracket on the front of machine.
4. Remove drain plug on the pump volute and drain the pump.
5. Remove the pump hoses.
6. Pull the pump/motor assembly forward out of the slip bracket in the machine base.
7. Disconnect the wires to the motor at the motor junction box.
8. Remove screws on volute and carefully remove from the pump flange.
9. Lock the motor shaft. The back of motor shaft has a screwdriver slot.
10. Turn the impeller clockwise to remove from shaft. (Shaft has left-hand threads)
11. Remove the spacer and save for reassembly.
12. Remove the old seal and discard.
13. Check seal seat in the pump flange and clean thoroughly.
14. Press rubber seal/ceramic portion of seal assembly into the pump flange.
Use a water soluble lubricant. Be careful to keep the ceramic clean.
15. Install the rotating part of the seal on the shaft with the graphite surface toward the ceramic. Use a water soluble lubricant.
16. Reinstall spacer, impeller, and new flange gasket. Reinstall screws.
17. Reinstall the pump/motor assembly and reconnect the pump hoses.
18. Test run and check for leaks.

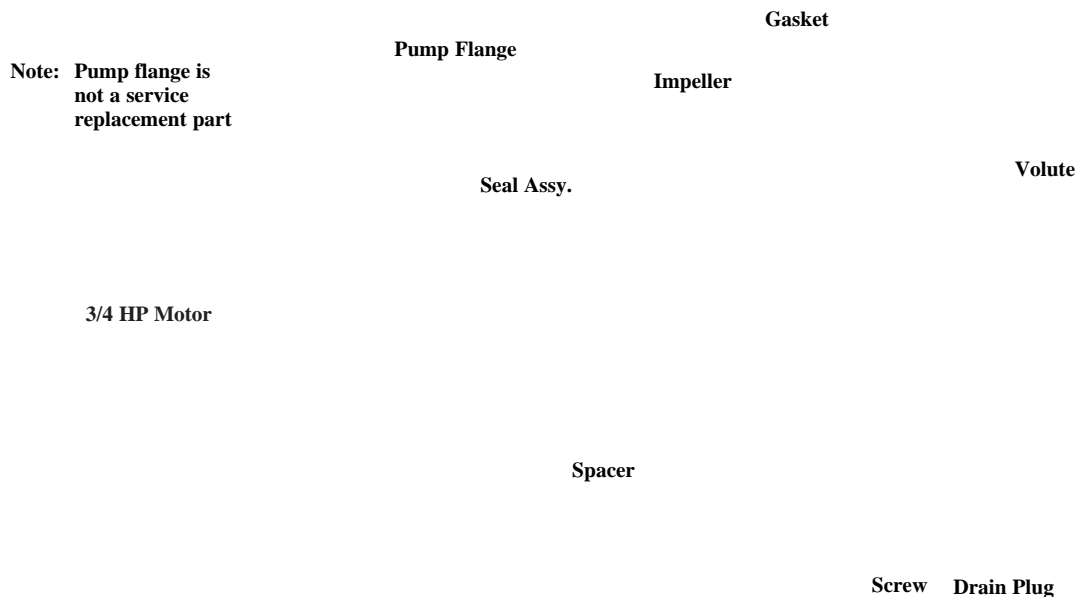
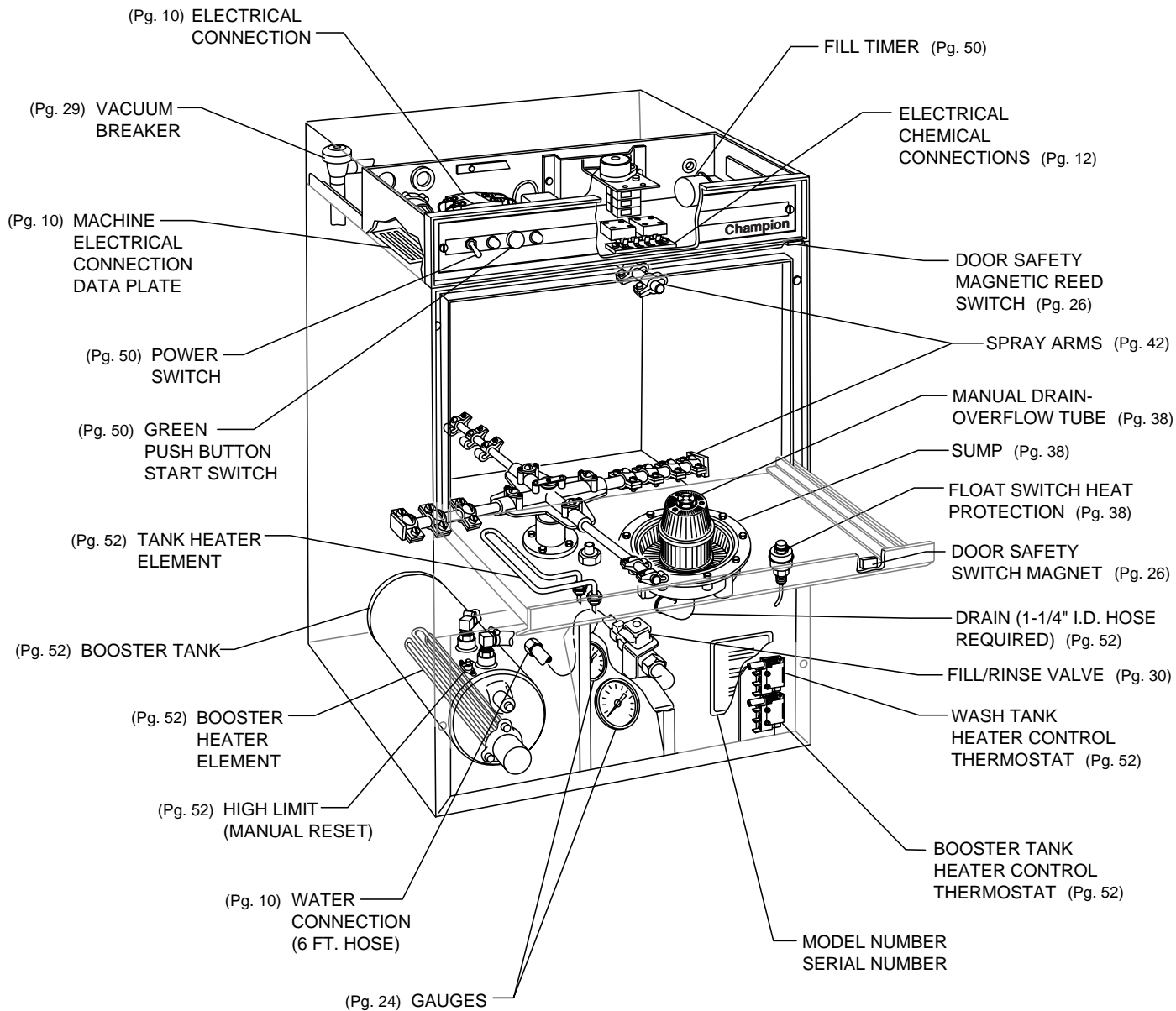

Figure 8
Pump Seal Replacement

Model U-HB Component Diagram



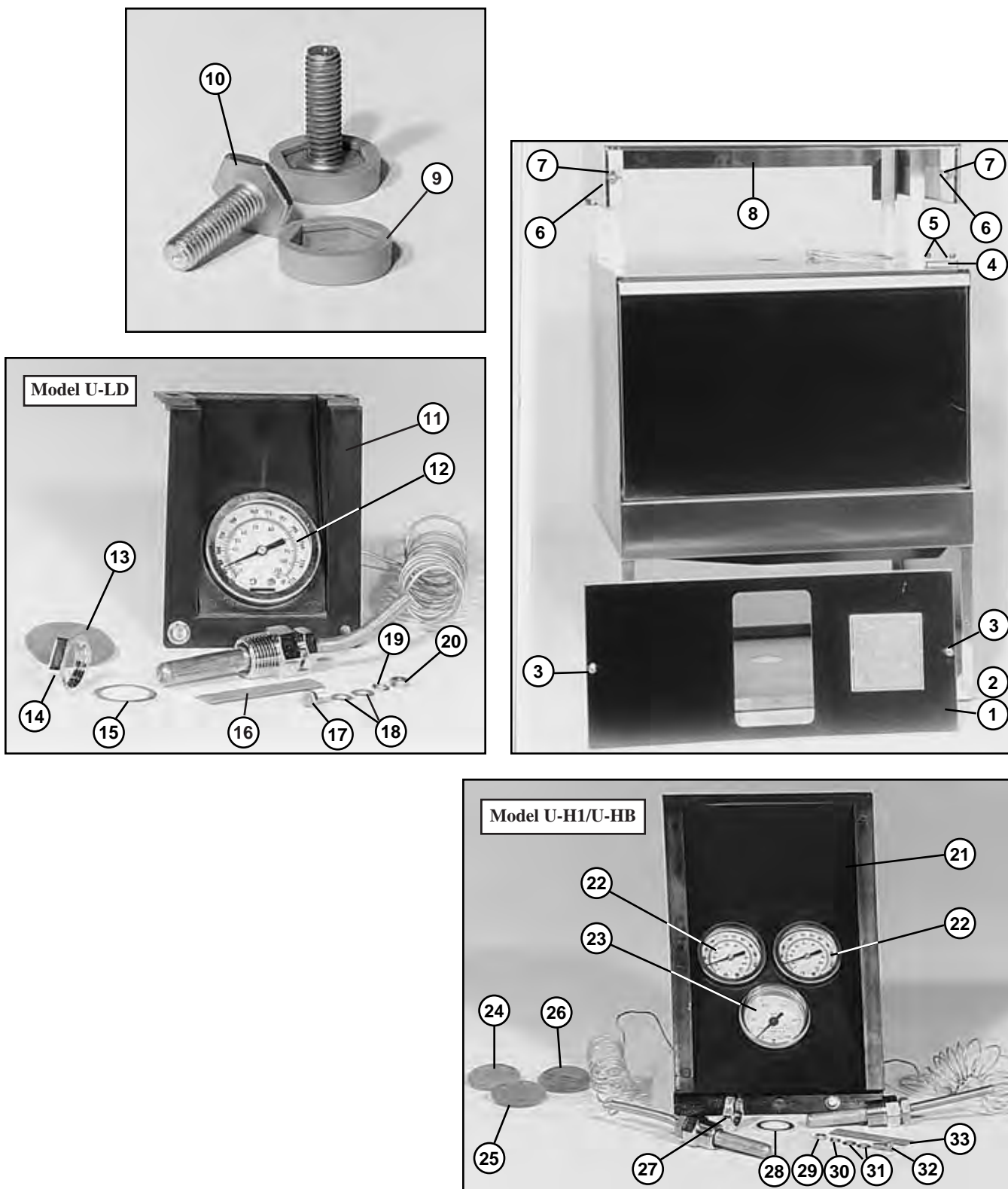

Figure 9 - U-H1/U-HB/U-LD Panels & Gauges

**U-H1/U-HB/U-LD
Panels, Gauges**

Fig. 9 Item No.	Part No.	Part Description	Qty.
1	310138	Panel, front (U-H1, U-HB)	1
2	310530	Panel, front (U-LD) (Not shown).....	1
3	100212	Screw (10-32 x 3/4 Truss Hd).....	2
4	109934	Switch, magnetic (door safety)	1
5	108954	Nut, grip (6-32 w/nylon insert)	2
6	110868	Clip, mounting.....	2
7	100097	Screw (10-32 x 1/2 Truss Hd).....	2
8	110223	Top cover assembly (U-H1, U-HB, U-LD)	1
9	108036	Cap 1-1/4" diameter	4
10	108035	FH leveler (3/8-16).....	4
11	110244	Bracket gauge (U-LD).....	1
12	108391	Thermometer 48"	1
13	107442	Overlay, temperature (120° - 140°).....	1
14	201029	Locknut (1/2")	1
15	201041	Washer (7/8 x 1 3/16 x 1/8)	1
16	104889	Compound 440 (Grey putty)	1 ft.
17	105254	Bolt (10-32 x 1/2 Hex Hd).....	2
18	107033	Washer (.208 x .437 x .047).....	4
19	106486	Washer, lock (#10 split)	2
20	104985	Nut, plain (10-32).....	2
21	110263	Bracket, gauge (U-H1, U-HB)	1
22	108391	Thermometer, 48"	2
23	109812	Gauge, pressure 0-100 psi.....	1
24	104748	Overlay, final rinse (180° - 195°).....	1
25	109816	Overlay, pressure gauge (20-30)	1
26	107444	Overlay, temperature (wash)(150° - 170°).....	1
27	201029	Locknut (1/2")	2
28	201041	Washer (7/8 x 1-3/16 x 1/8)	2
29	104985	Nut, plain.....	2
30	106486	Washer, lock (#10 split)	2
31	107033	Washer (.208 x .437 x .047).....	4
32	105254	Bolt (10-32 x 1/2 Hex Hd).....	2
33	104889	Compound 440 (Grey putty)	1 ft.

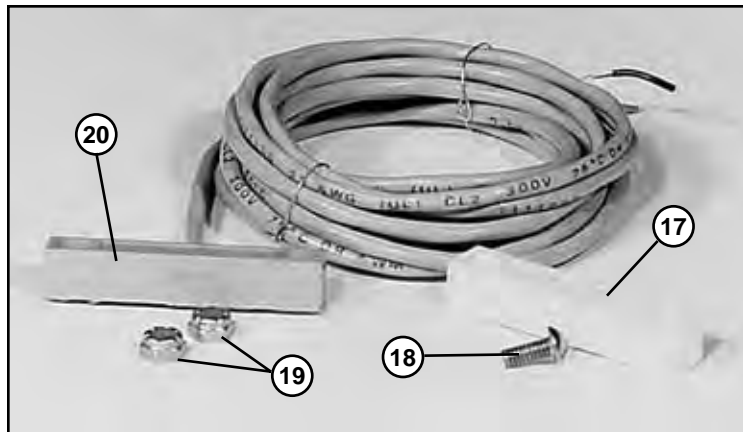
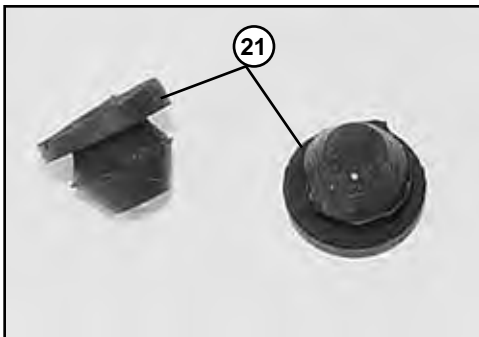
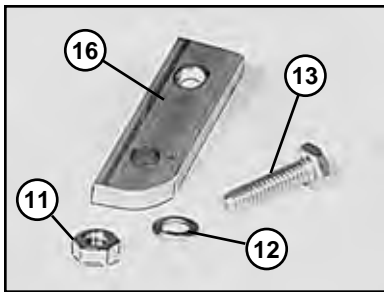
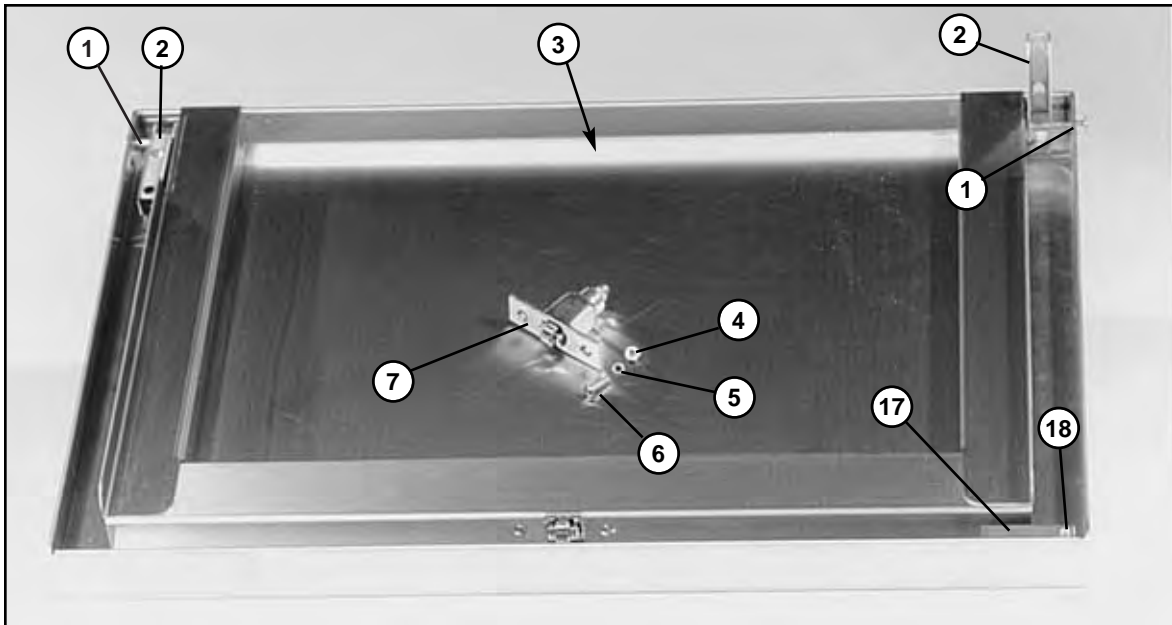

Figure 10 - U-H1/U-HB/U-LD Door, Tracks, Safety Switch

U-H1/U-HB/U-LD
Door, Tracks, Safety Switch

Fig. 10 Item No.	Part No.	Part Description	Qty.
1	110228	Pin, door	2
2	110229	Support, door.....	2
3	0708691	Door (Does not include items 1, 2, 4-7, 17, 18).....	1
4	104985	Nut, plain (10-32).....	2
5	106486	Washer, lock (#10 split)	2
6	110159	Screw (8-32 x 5/8 Round Hd SST).....	2
7	110233	Catch, door	1
8	107137	Bolt, (10-32 x 7/8 Hex Hd).....	4
9	0308693	Rack guide, RH	1
10	0308692	Rack guide, LH	1
11	100003	Nut, plain (1/4-20 SST).....	4
12	106482	Washer, lock (1/4 split)	4
13	100738	Bolt (1/4-20 x 1 Hex Hd).....	4
14	0308696	Baffle, splash RH	1
15	0308695	Baffle, splash LH	1
16	0508694	Stop, door	2
17	109935	Magnet, door safety.....	1
18	102564	Screw (8-32 x 3/8 Round Hd).....	1
19	108954	Nut, grip (6-32 w/nylon insert)	2
20	109934	Switch, magnet (door safety)	1
21	107893	Shock absorber, door.....	2

Model U-H1 and U-HB Only

Beginning with S/N 85680 and above.

Items 4, 5, 14 added and Final Rinse Thermometer now located in Item 5, 1/2" Brass Cross Fitting. (See Photo Below.)

Prior to S/N 85680.

Item 5 was P/N 107892, Tee Connector. Items 4, 14 were not used. Final Rinse Thermometer was located on Booster for U-HB and on Manifold for U-H1.

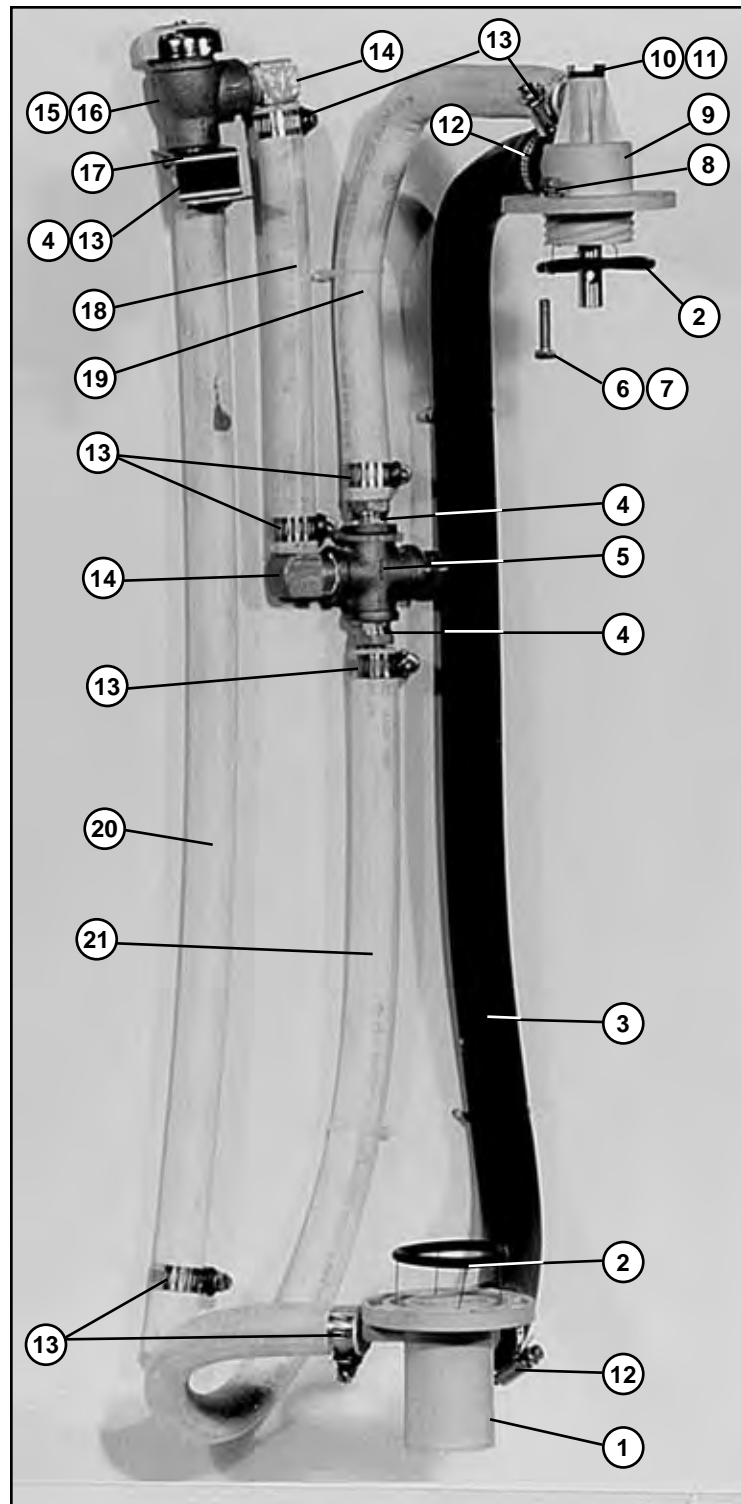
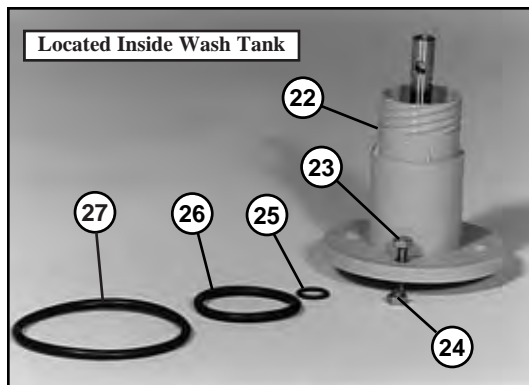
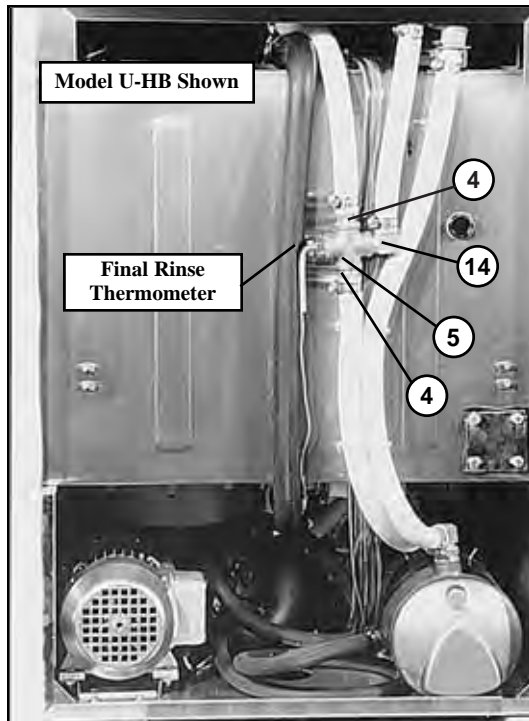

Figure 11 - U-H1/U-HB Plumbing

U-H1/U-HB PLUMBING

Fig. 11 Item No.	Part No.	Part Description	Qty.
1	109463	Tee, lower wash arm	1
2	109466	O-ring, wash arm tee	2
3	110210	Hose, wash	1
4	107419	Barb, hose (1/2 x 1/2 NPT brass).....	3
5	100598	Cross (1/2" brass) Beginning w/ S/N 85680.....	1
6	100736	Bolt (1/4-20 x 3/4 Hex Hd).....	4
7	110881	Washer, sealing (not shown)	4
8	100141	Nut , grip (1/4-20 SST).....	4
9	109459	Tee, upper wash.....	1
10	110215	Screw, special	1
11	104889	Compound 440 (Grey putty)	1 ft.
12	105993	Clamp, hose.....	2
13	111750	Clamp, hose.....	8
14	108528	Barb, hose (1/2 x 1/2 NPT 90° brass).....	2
15	100500	Breaker, vacuum (1/2")	1
16	108349	Kit, repair vacuum breaker (not shown)	1
17	310198	Bracket, vacuum breaker.....	1
*18	107417	9" hose (1/2" ID).....	1
*19	107417	17" hose (1/2" ID).....	1
*20	107417	34" hose (1/2" ID).....	1
*21	107417	24" hose (1/2" ID).....	1
22	109468	Arm Support, lower wash	1
23	110440	Bolt (25mm Hex Hd)	4
24	110214	Dull Nut (M6)	4
25	109460	O-ring, lower wash arm	1
26	109466	O-ring, lower wash arm	1
27	109467	O-ring, lower wash arm	1

* P/N 107417 sold by the foot (Items 18-21)

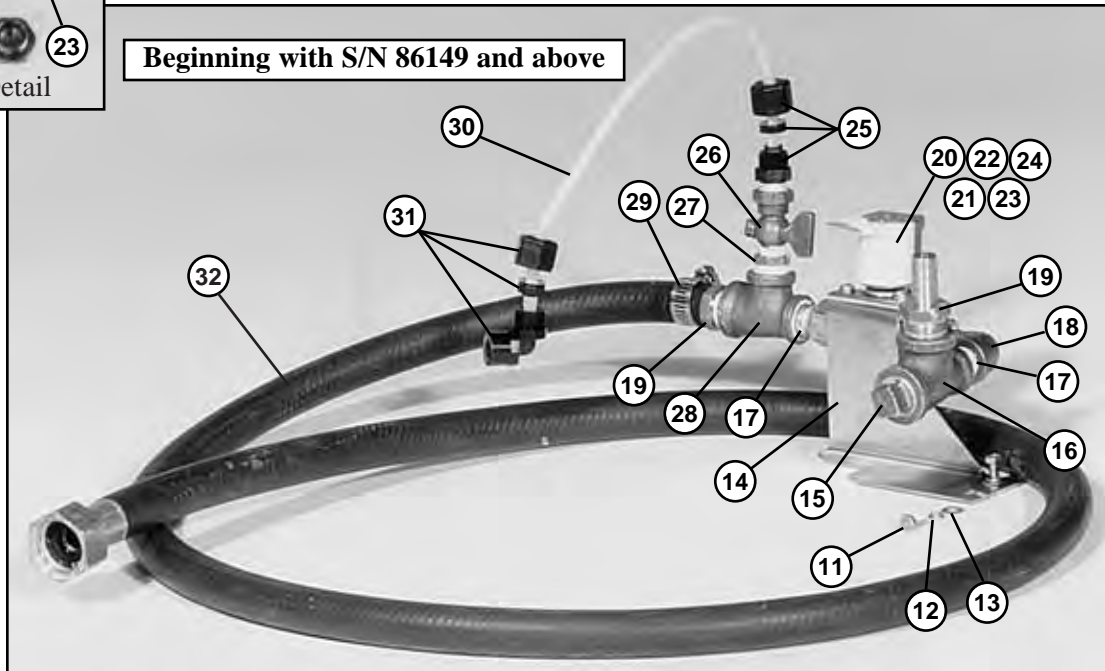
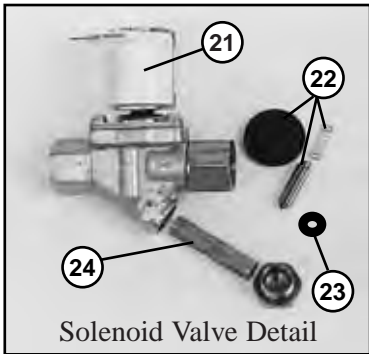
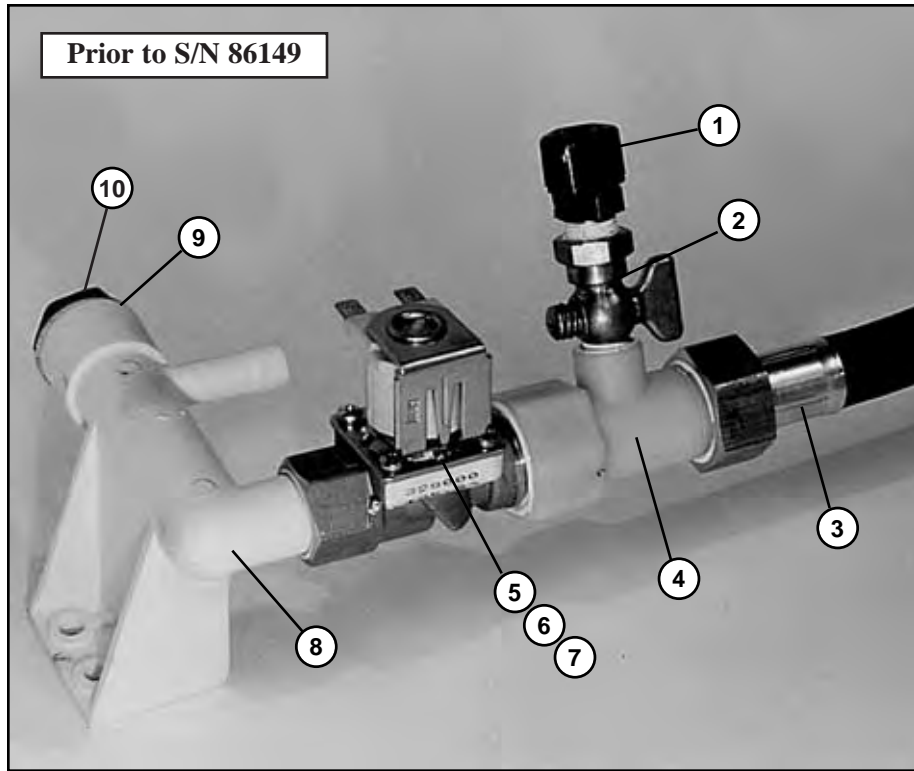

Figure 12 - U-H1/U-HB Fill Solenoid Valve and Piping

**U-H1/U-HB
FILL SOLENOID VALVE AND PIPING**

Fig. 12 Item No.	Part No.	Part Description	Qty.
1	107065	Connector, male (1/4 OD x 1/4 NPT).....	1
2	100123	Cock, gauge (1/4")	1
3	110915	Hose, fill (6 ft.).....	1
4	109689	Adapter, tee	1
5	204348	Valve, solenoid	1
6	108010	Coil, solenoid valve (240V)	1
7	109386	Diaphragm, solenoid valve (not shown)	1
8	108713	Manifold (1/2")	1
9	109034	Washer, fiber (13/16 x 1 1/16)	1
10	108418	Plug (1/2").....	1
11	105254	Bolt (10-32 x 1/2 Hex Hd).....	2
12	106486	Washer, lock (#10 split)	2
13	107033	Washer (.208 x .437 x .047).....	2
14	317872	Bracket	1
15	102504	Plug (1/2" brass).....	1
16	102516	Tee (3/8 x 1/2 x 1/2 brass)	3
17	100998	Nipple, close (3/8" brass).....	2
18	102431	Elbow, street (3/8" 90° brass)	1
19	107419	Barb, hose (1/2 x 1/2 NPT brass).....	2
20	111714	Valve, solenoid (240V coil)	1
21	0502806	Coil, solenoid valve (240V)	1
22	0502811	Kit, diaphragm (See valve detail)	1
23	111733	Flow washer (See valve detail)	1
24	0502803	Strainer, line (See valve detail)	1
25	107065	Connector, male (1/4 OD x 1/4 NPT).....	1
26	100123	Cock, gauge (1/4")	1
27	102401	Bushing, reducer (3/8 x 1/4 Hex brass)	1
28	102515	Tee (1/2 x 3/8 x 3/8 brass)	1
29	105994	Clamp, hose.....	1
30	107414	Tubing, high density.....	2 ft.
31	111100	Elbow, female (1/4 OD x 1/8 NPT)	1
32	111715	Hose, fill (1/2")	1
—	900742	Kit, fill piping assy (U-HB only) (includes items 14-20, 25-29, 32)	

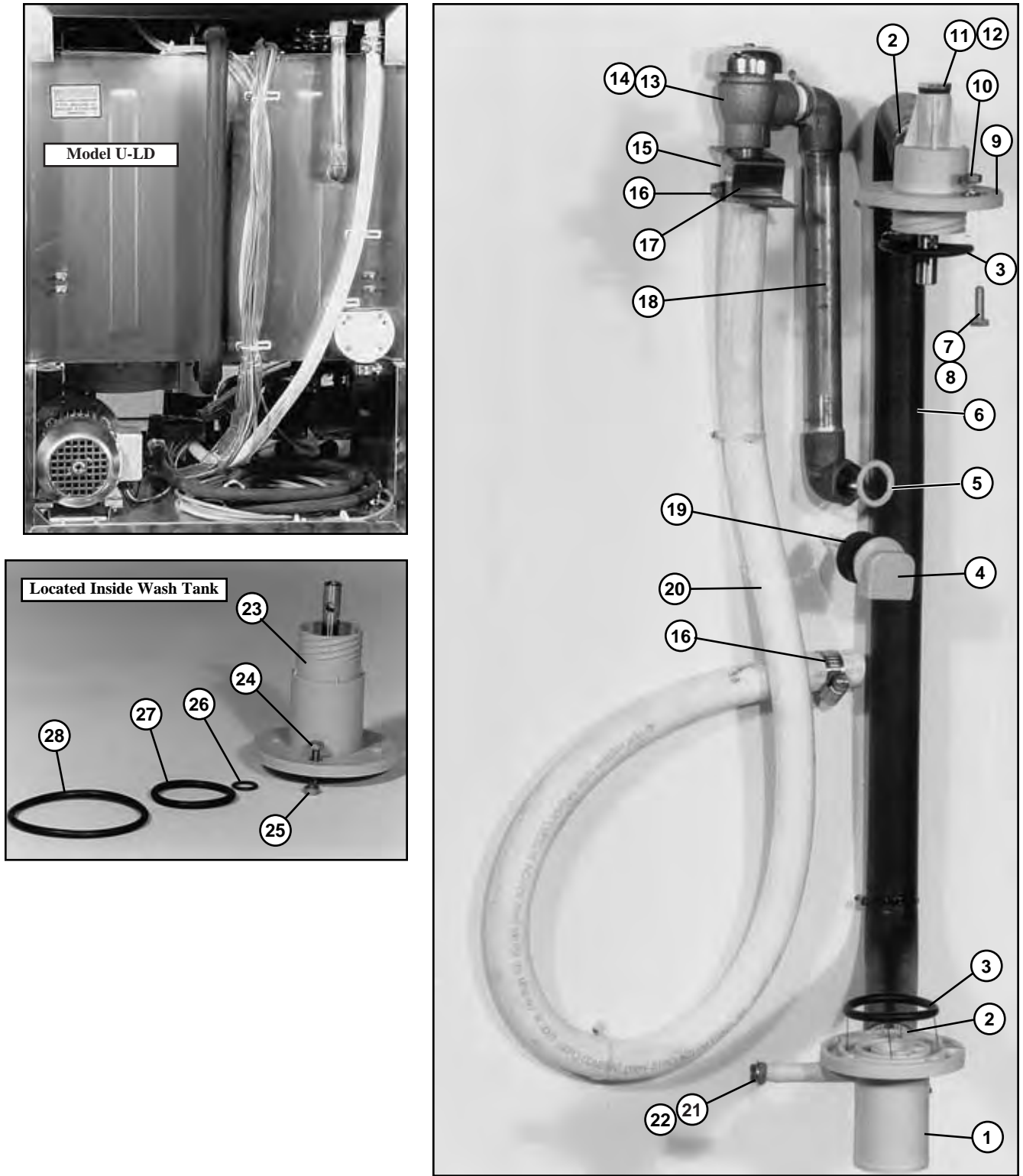

Figure 13 - U-LD Plumbing

U-LD PLUMBING

Fig. 13 Item No.	Part No.	Part Description	Qty.
1	109463	Tee, lower wash arm	1
2	105993	Clamp, hose.....	2
3	109466	O-ring, wash arm tee	3
4	106153	Nozzle.....	1
5	109034	Washer, fiber (13/16 x 1/16)	1
6	110210	Hose, wash	1
7	100736	Bolt (1/4-20 x 3/4 Hex Hd).....	4
8	110881	Washer, sealing (Not shown)	4
9	109459	Tee, upper wash arm	1
10	100141	Nut, grip (1/4-20 SST)	4
11	110215	Screw, special	1
12	104889	Compound 440 (Grey putty)	1 ft.
13	100500	Breaker, vacuum (1/2")	1
14	108349	Kit, repair vacuum breaker (Not shown)	1
15	107419	Barb, hose (1/2 x 1/2 NPT Brass).....	1
16	111750	Clamp, hose.....	2
17	310198	Bracket, vacuum breaker.....	1
18	601066	Piping	1
19	108417	Nut (1/2")	1
*20	107417	48" hose (1/2" OD)	1
21	100111	Bolt (5/16-18 x 5/8 Hex Hd).....	1
22	104889	Compound 440 (Grey putty)	1
23	109468	Arm Support, lower wash	1
24	110440	Bolt (25mm Hex Hd)	4
25	110214	Dull Nut (M6)	4
26	109460	O-ring, lower wash arm	1
27	109466	O-ring, lower wash arm	1
28	109467	O-ring, lower wash arm	1

* P/N 107417 sold by the foot (Item 20)

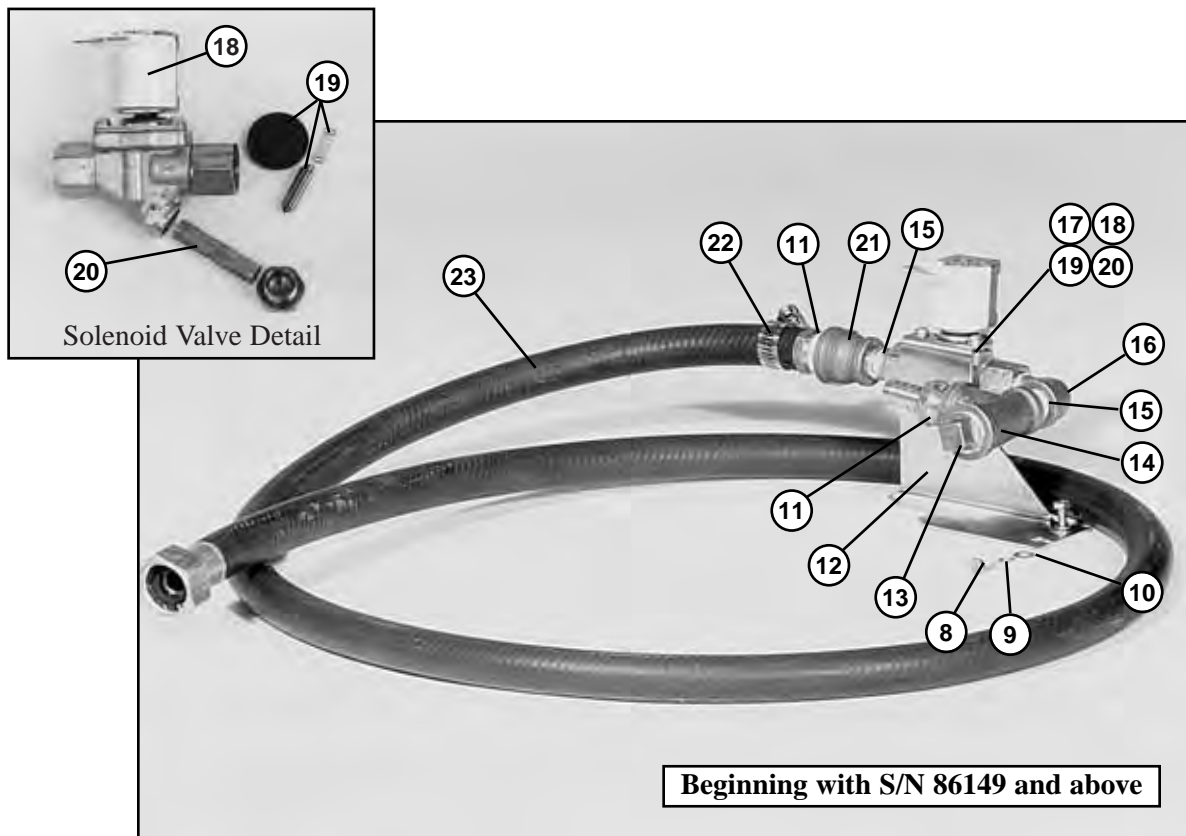
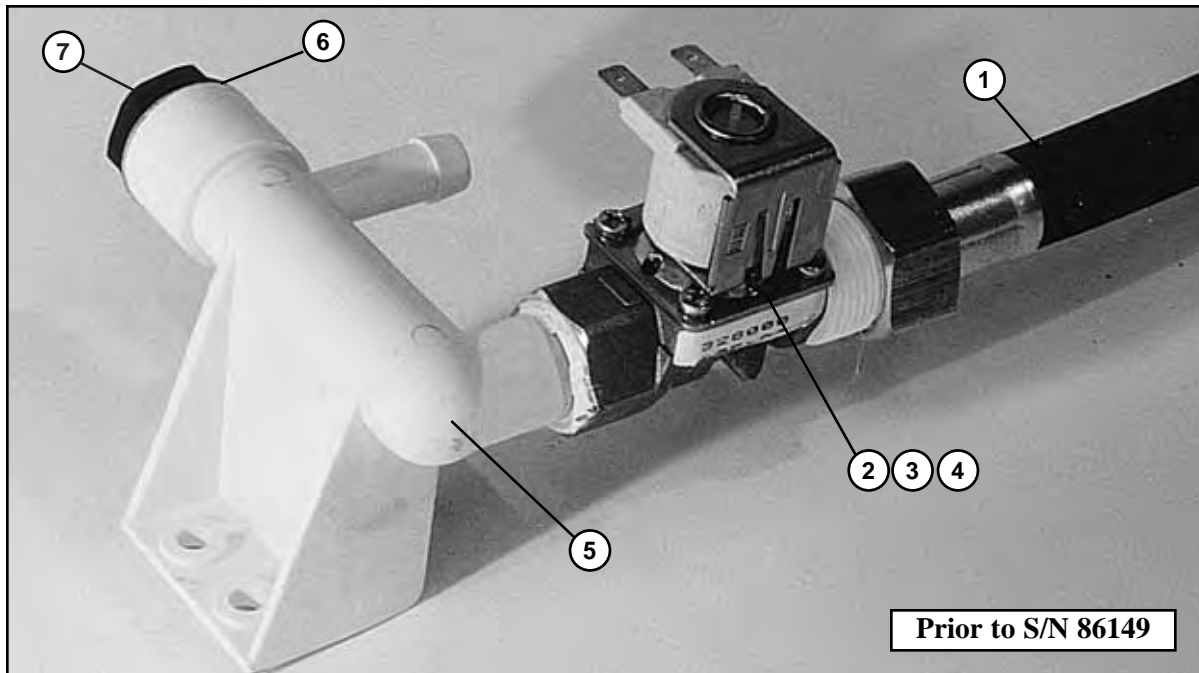

Figure 14 - U-LD Fill Solenoid Valve and Piping

U-LD PLUMBING

Fig. 14 Item No.	Part No.	Part Description	Qty.
1	110915	Hose, fill (1/2")	1
2	204347	Valve, solenoid (120V)	1
3	108877	Coil, solenoid valve (120V)	1
4	109386	Diaphragm, solenoid valve (Not shown)	1
5	108713	Manifold (1/2")	1
6	109034	Washer, fiber (13/16 x 1/16)	1
7	108418	Plug (1/2")	1
8	105254	Bolt (10-32 x 1/2 Hex Hd)	2
9	106486	Washer, lock (#10 split)	2
10	107033	Washer (.208 x .437 x .047)	2
11	107419	Barb, hose (1/2 x 1/2 NPT Brass)	2
12	317872	Bracket, solenoid valve	1
13	102504	Plug (1/2" Brass)	1
14	102516	Tee (3/8 x 1/2 x 1/2 Brass)	1
15	100998	Nipple, close (3/8")	1
16	102431	Elbow, street (3/8" 90° Brass)	1
17	111734	Valve, solenoid (120V)	1
—	Note: U-LD solenoid valve does not have a flow washer		
18	0505235	Coil, solenoid valve (120V)	1
19	0502811	Kit, diaphragm, (See valve detail)	1
20	0502803	Strainer, line (See valve detail)	1
21	102414	Coupling, reducer (1/2 x 3/8 Brass)	1
22	105994	Clamp, hose	1
23	111715	Hose, fill (1/2")	1

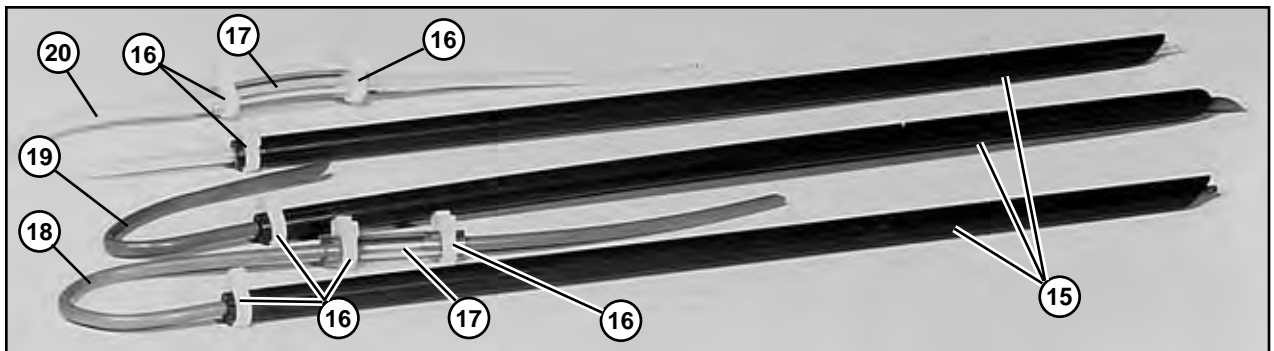
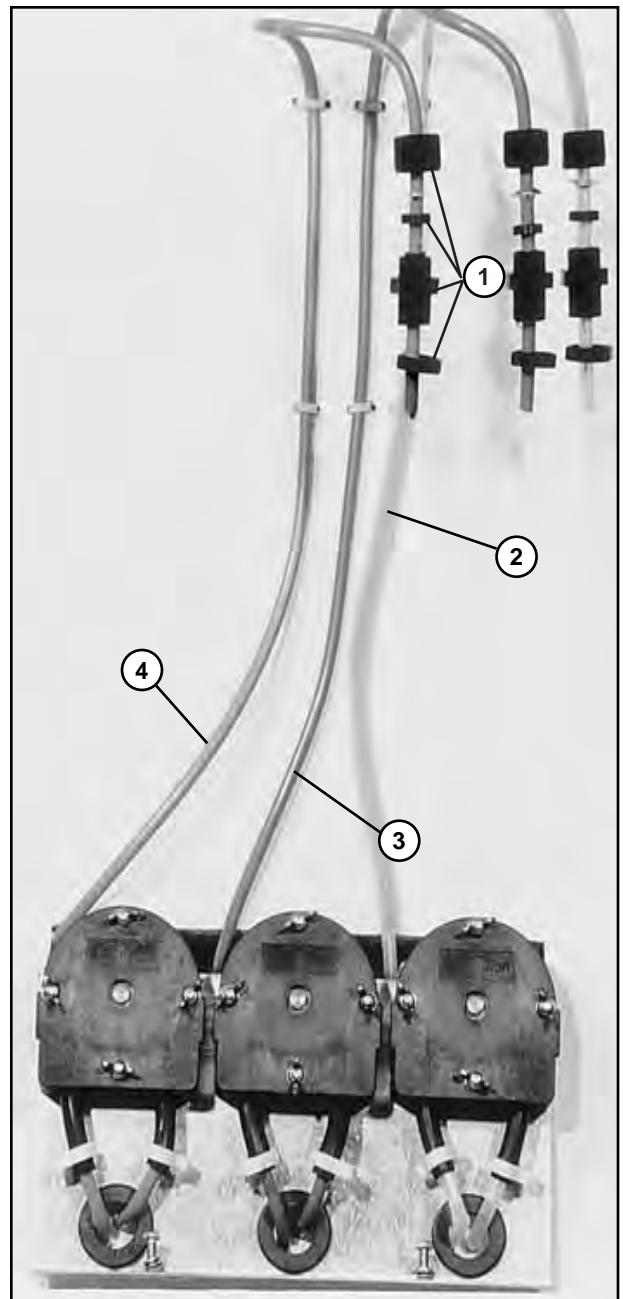
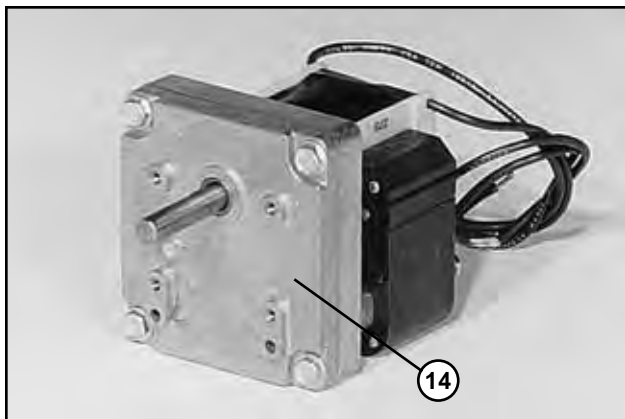
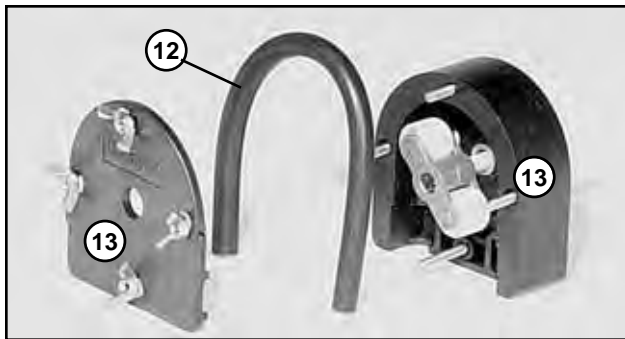
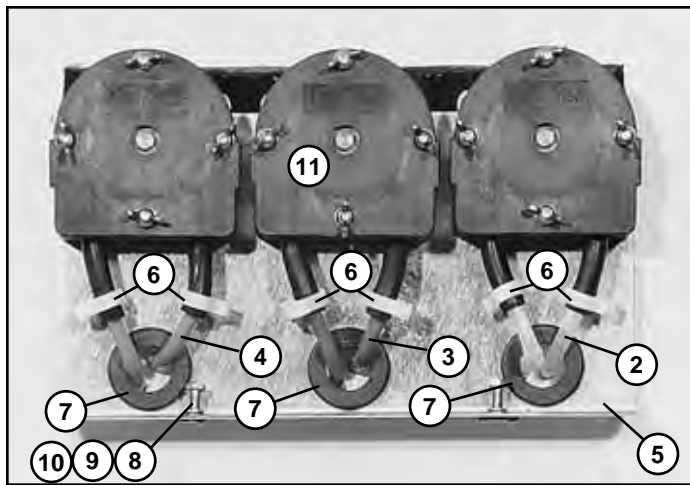

Figure 15 - U-LD Chemical Dispensing System

**U-LD
CHEMICAL DISPENSING SYSTEM**

Fig. 15 Item No.	Part No.	Part Description	Qty.
1	203194	Union, bulkhead	3
2	107928	Tubing, natural - tank to pump (Sanitizer)	6 ft.
3	107930	Tubing, blue - tank to pump (Rinse aid).....	6 ft.
4	107929	Tubing, red - tank to pump (Detergent).....	6 ft.
5	305248	Plate, dispenser holding	1
6	108411	Clamp, hose (SNP-2)	6
7	107050	Grommet (1 3/8 x 3/4)	3
8	107033	Washer (.208 x .437 x .047).....	2
9	106486	Washer, lock (#10 split)	2
10	105254	Bolt (10-32 x 1/2 Hex Hd).....	6
11	405853	Kit, Chemical dispensing (Incls. 5-7)	1
12	108194	Tube (3/16 ID x 3/8 OD)	3
13	109829	Pump, peristaltic (Includes item #12)	3
14	108299	Motor, reducer (35 RPM 120V).....	3
15	107931	Tubing, pick-up (1/4 x 18).....	3
16	108412	Clamp, hose (SNP-6)	7
17	107935	Tube (5/8 ID x 15/16 OD)	2
18	107929	Tubing, red - pump to supply (Detergent)	6 ft.
19	107930	Tubing, blue - pump to supply (Rinse aid)	6 ft.
20	107928	Tubing, natural - pump to supply (Sanitizer).....	6 ft.
-	107938	Kit, Chemical dispensing (Includes 12 - 14)	

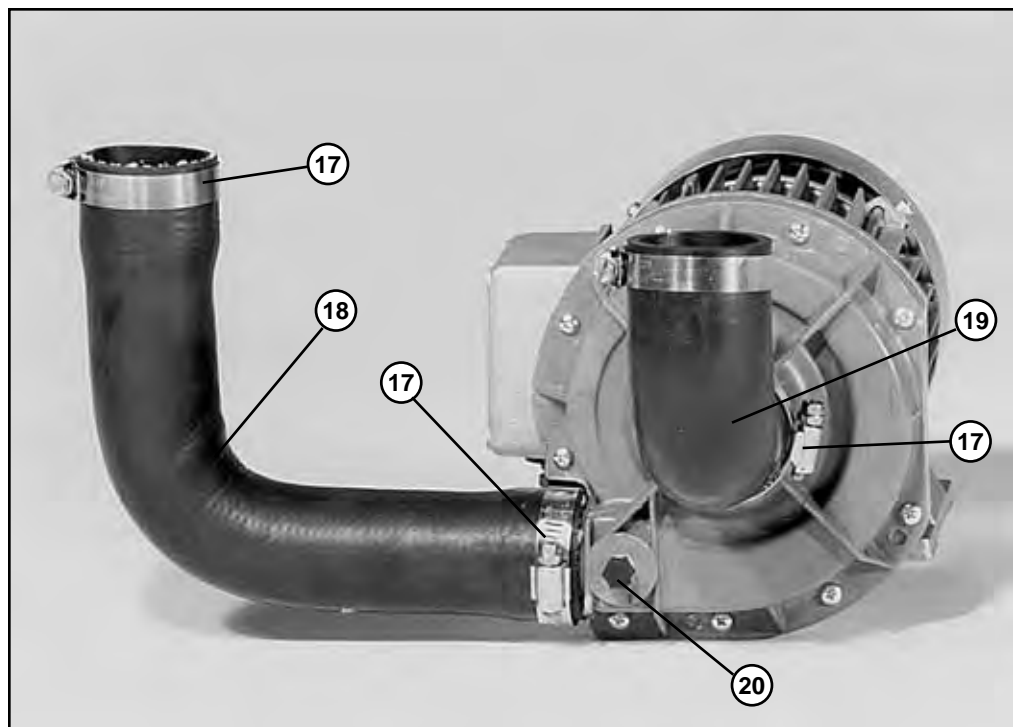
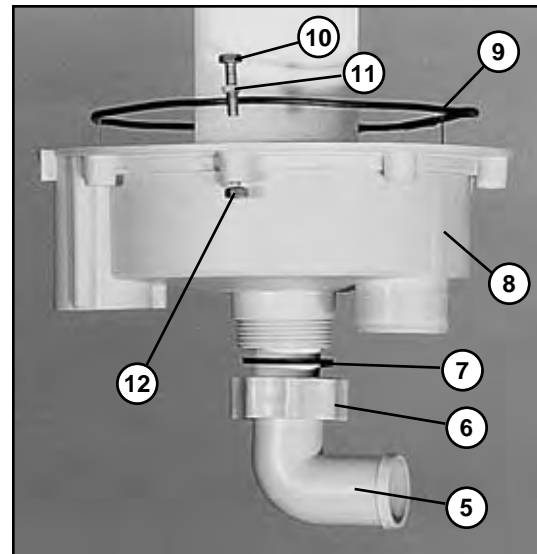
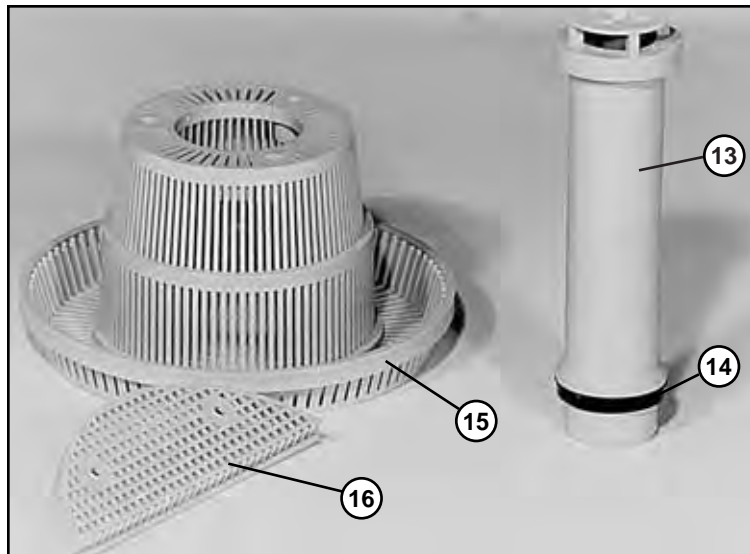
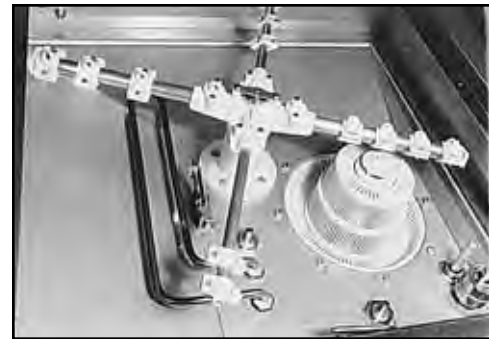
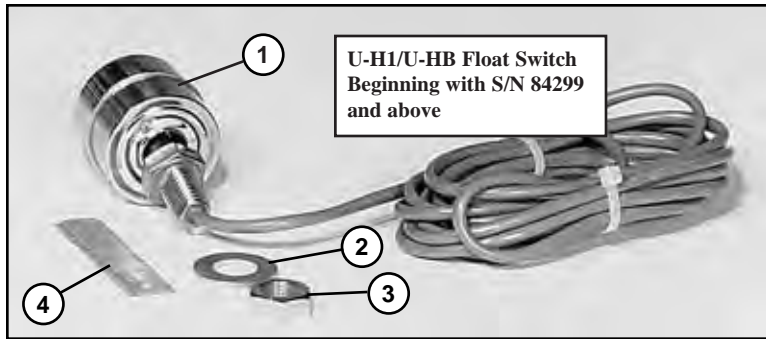

Figure 16 - U-H1/U-HB Float Switch, Sump, Pump Hoses

**U-H1/U-HB
FLOAT SWITCH, SUMP, PUMP HOSES**

Fig. 16 Item No.	Part No.	Part Description	Qty.
1	111443	Float switch assembly	1
2	205138	Washer	1
3	104584	Nut, plain (1/2-13 Hex SST)	1
4	104889	Compound 440 (Grey putty)	1 ft.
5	109284	Tailpiece, elbow (Drain connection)	1
6	107867	Nut, outlet pipe	1
7	107866	Washer, packing	1
8	110739	Sump (Beginning with S/N 79001 and above)	1
8	110219	Sump, with air trap (Beginning with S/N 76701 thru 79000) ...	1
9	109465	O-ring	1
10	110440	Bolt (25mm Hex Hd)	8
11	110881	Washer, sealing	8
12	110214	Dull Nut (M6)	8
13	110218	Tube, drain-overflow	1
14	110427	Seal, drain-overflow tube	1
15	109462	Filter, sump	1
16	109464	Strainer, pump	1
17	107340	Clamp, hose	4
18	110209	Hose, pump discharge	1
19	110211	Hose, pump intake	1
20	107424	Plug (1/8")	1

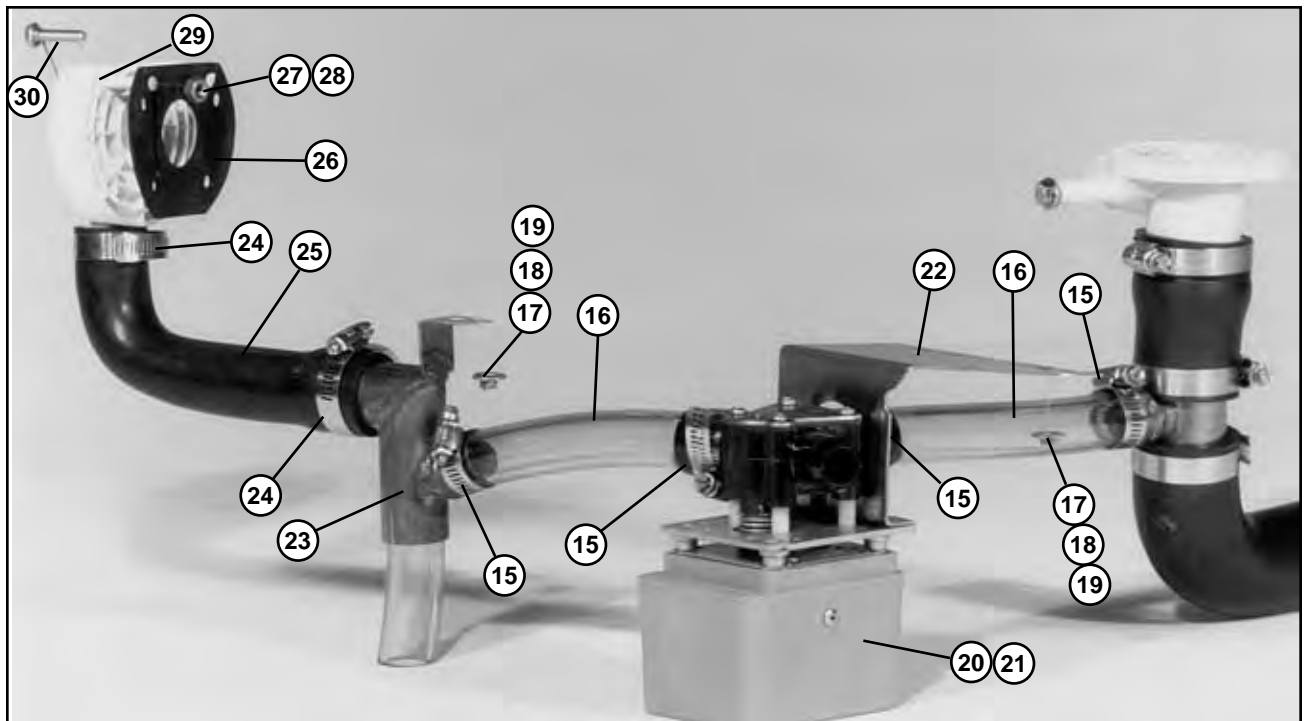
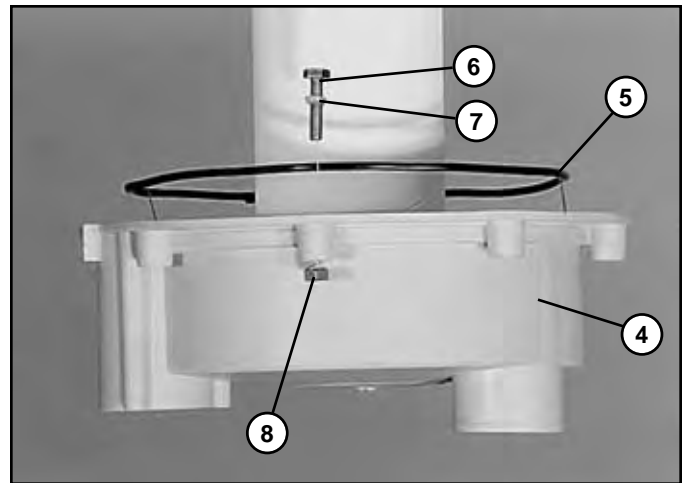
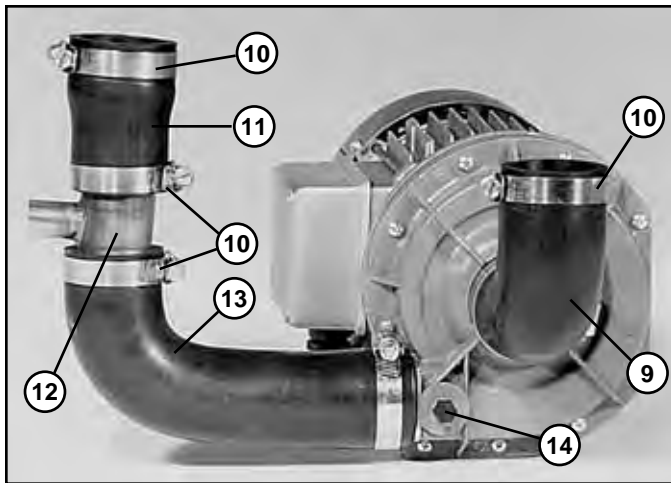
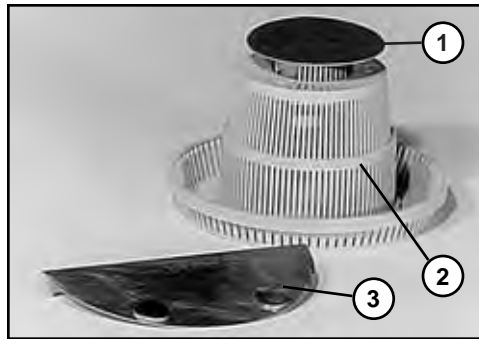

Figure 17 - U-LD Sump, Pump Hoses, Drain Assembly

U-LD
SUMP, PUMP HOSES, DRAIN ASSY

Fig. 17 Item No.	Part No.	Part Description	Qty.
1	313545	Overflow cover.....	1
2	109462	Filter, sump.....	1
3	316797	Plate, strainer.....	1
4	109461	Sump.....	1
5	109465	O-ring.....	1
6	110440	Bolt (25mm Hex Hd).....	8
7	110881	Washer, sealing.....	8
8	110214	Dull Nut (M6).....	8
9	110211	Hose, pump intake.....	1
10	107340	Clamp, hose.....	6
11	110699	Hose, upper discharge.....	1
12	312167	Drain tee, wash.....	1
13	110698	Hose, lower discharge.....	1
14	107424	Plug (1/8").....	1
15	105994	Clamp, hose.....	4
*16	110067	10" tubing (3/4 ID x 1 1/16 OD).....	2
17	106486	Washer, lock (#10 split).....	3
18	107033	Washer (.208 x .437 x .047).....	3
19	108441	Nut (M5 Hex Hd).....	3
20	111522	Valve, drain (120V).....	1
21	405265	Kit, drain valve (Incls. 12, 15, 16, 22).....	1
22	317020	Bracket, support.....	1
23	312166	Drain tee.....	1
24	107340	Clamp, hose.....	2
25	110264	Hose, overflow drain.....	1
26	107886	Gasket.....	1
27	107420	Nut, plain (M6 SST).....	4
28	106482	Washer, lock (1/4 split).....	4
29	108051	Flange, elbow.....	1
30	110440	Bolt (25mm Hex Hd).....	4

* P/N 110067 sold by the foot (Item 16)

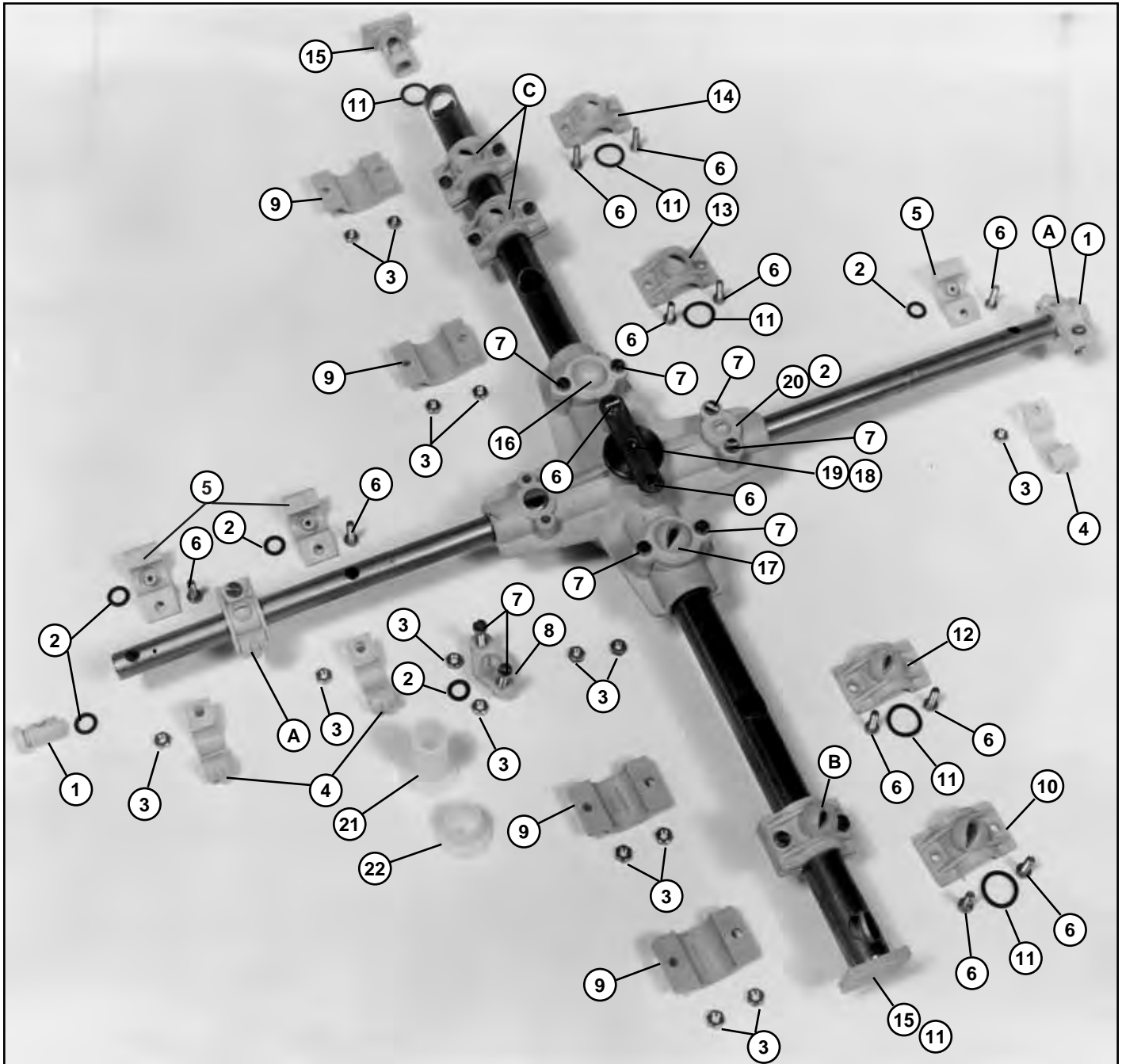

Figure 18 - U-H1/U-HB Wash Arm Assembly

U-H1/U-HB
WASH ARM ASSEMBLY
(Quantities listed per one wash arm assembly)

Fig. 18 Item No.	Part No.	Part Description	Qty.
1	107329	Plug, rinse arm	2
2	108016	O-ring	9
3	107337	Nut, plain (M4)	27
4	107330	Nozzle, bottom rinse	5
5	108730	Nozzle, top rinse	5
6	107336	Screw (M4 x 12mm Pan Hd)	19
7	109491	Screw (M4 x 25mm)	8
8	109834	Cap, rinse center.....	1
9	107332	Nozzle, bottom wash.....	7
10	107335	Nozzle, top wash (RH).....	1
11	108021	O-ring	9
12	108364	Nozzle, top wash (RH).....	2
13	108365	Nozzle, top wash (LH).....	3
14	107334	Nozzle, top wash (LH).....	1
15	107328	Plug, wash arm.....	2
16	109488	Nozzle, wash arm.....	1
17	109489	Nozzle, wash arm.....	1
18	109836	Bracket, retaining screw.....	1
19	109837	Screw, retaining.....	2
20	109833	Nozzle, rinse center.....	1
21	110395	Bearing, lower plastic hub (long).....	1
22	110394	Bearing, upper plastic hub (short).....	1
—	404808	Wash arm assembly (Incls 1-22).....	2
A	—	Rinse nozzle (Items 2-6) (assembled for reference)	
B	—	Wash nozzle (RH) (Items 3,6,9,11,12) (assembled for reference)	
C	—	Wash nozzle (LH) (Items 3,6,9,11,13) (assembled for reference)	

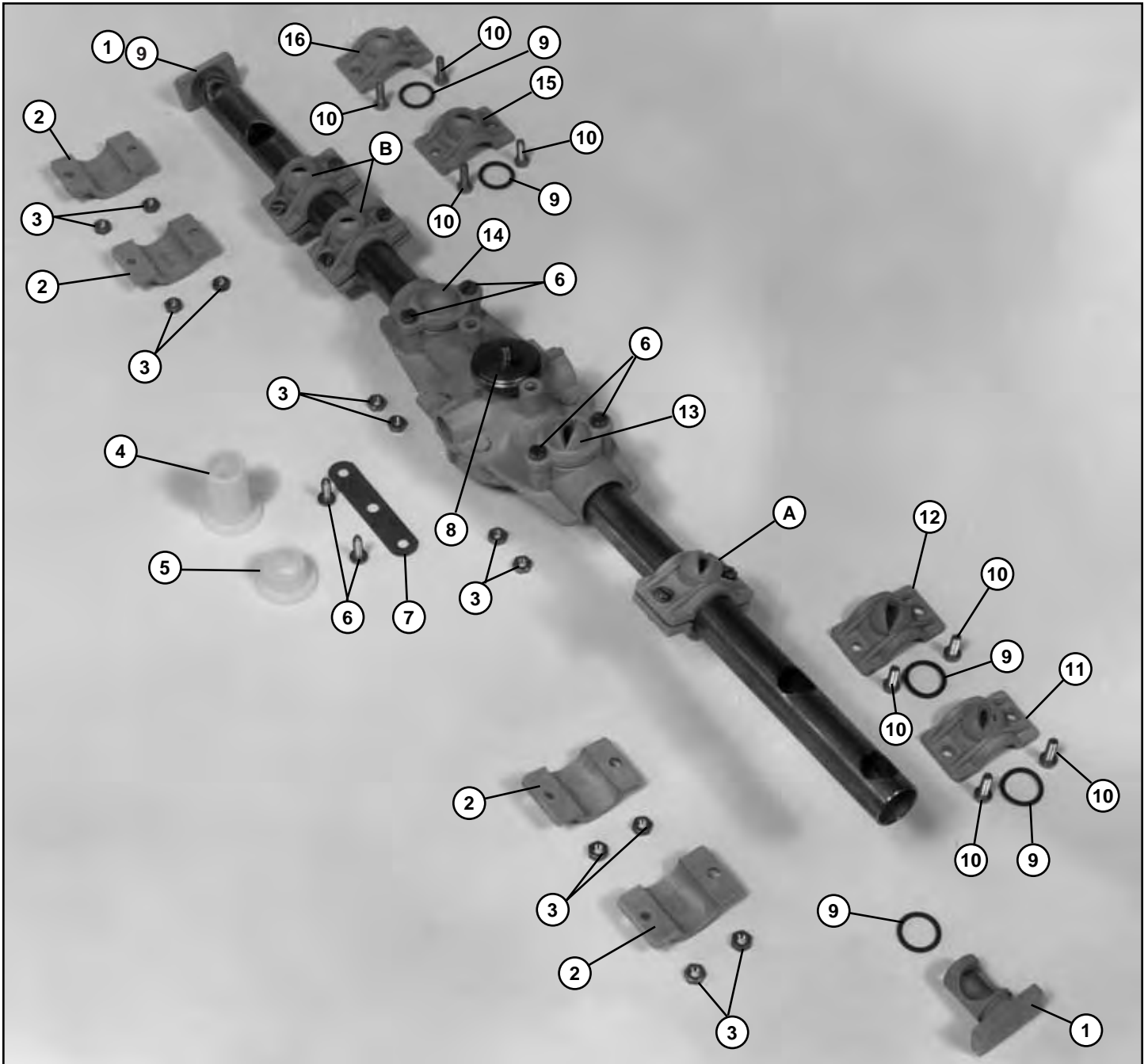
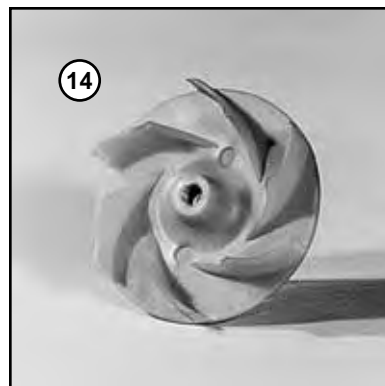
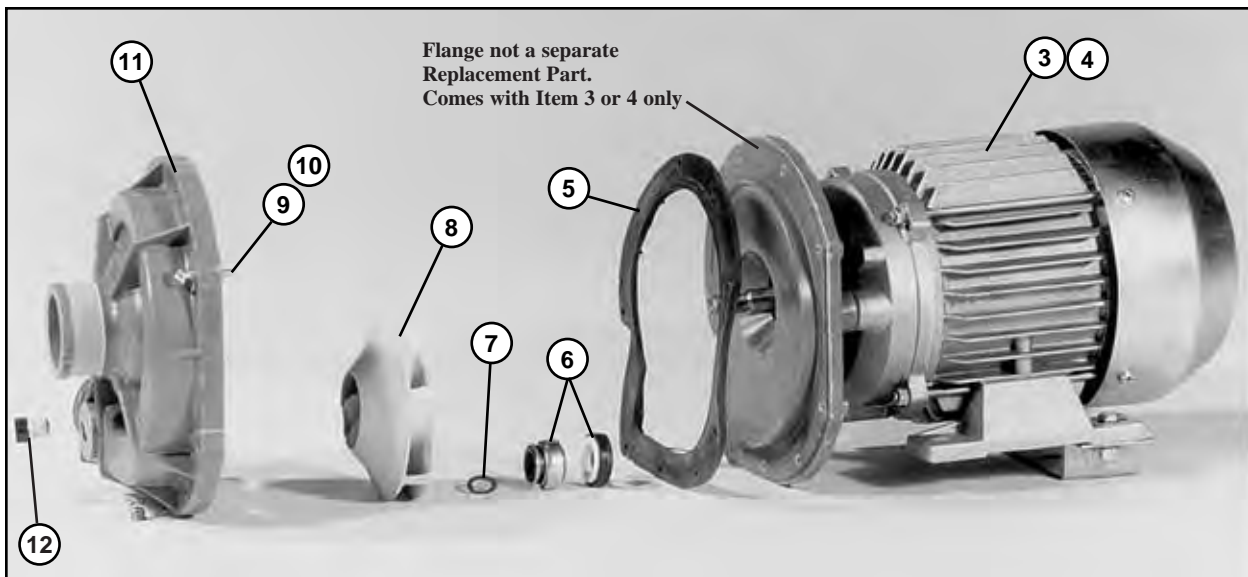
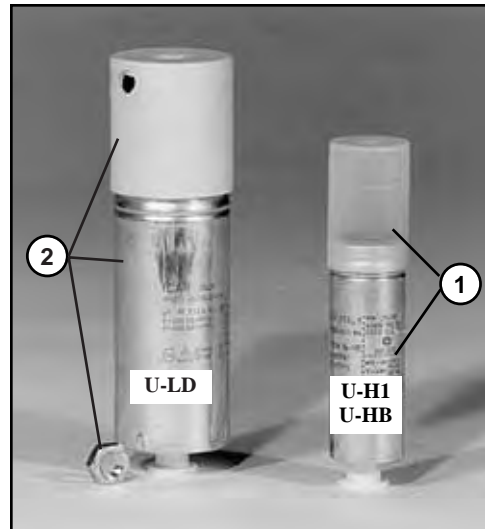

Figure 19 - U-LD Wash Arm Assembly

U-LD
WASH ARM ASSEMBLY
(Quantities listed per one wash arm assembly)

Fig. 19 Item No.	Part No.	Part Description	Qty.
1	107328	Plug, wash arm	2
2	107332	Nozzle, bottom wash	7
3	107337	Nut, plain (M4)	18
4	110395	Bearing, lower plastic hub (long).....	1
5	110394	Bearing, upper plastic hub (short).....	1
6	109491	Screw (M4 x 25mm Pan Hd)	6
7	109836	Bracket , retaining screw	1
8	109837	Screw, retaining	1
9	108021	O-ring	9
10	107336	Screw (M4 x 12mm Pan Hd)	14
11	107335	Nozzle, top wash (RH).....	1
12	108364	Nozzle, top wash (RH).....	2
13	109489	Nozzle, wash arm	1
14	109488	Nozzle, wash arm	1
15	108365	Nozzle, top wash (LH)	3
16	107334	Nozzle, top wash (LH)	1
—	404804	Wash, arm assembly (Incls items 1-16)	2
A	—	Wash nozzle (Items 3,9,10,12)(assembled for reference)	
B	—	Wash nozzle (Items 3,9,10,15)(assembled for reference)	



Model U-LD

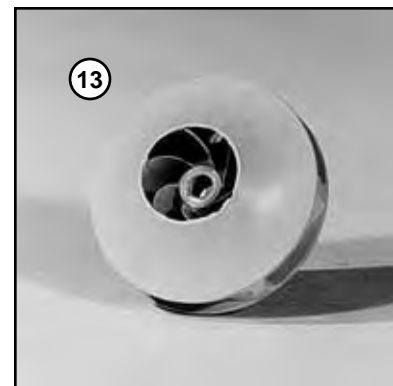

Model U-H1/U-HB

Figure 20 - Pump/Motor Assembly

PUMP/MOTOR ASSEMBLY

Fig. 20 Item No.	Part No.	Part Description	Qty.
1	109445	Capacitor (12.5 mfd) (U-H1/U-HB)	1
2	109446	Capacitor (40 mfd) (U-LD).....	1
3	110417	Pump/motor 3/4 HP (220V/60/1) (U-H1/U-HB).....	1
4	110416	Pump/motor 3/4 HP (115V/60/1) (U-LD)	1
5	110285	Gasket.....	1
6	108002	Seal assembly	1
7	111737	Spacer	1
8	—	See Item 13 or 14 below	—
9	107971	Screw (8-32 x 1-1/4 Pan Hd)	10
10	107965	Nut, grip (8-32 with nylon insert).....	10
11	110284	Volute, pump	1
12	107424	Plug (1/8").....	1
13	108003	Impeller (U-H1/U-HB) (Closed face).....	1
14	109434	Impeller (U-LD) (Open faced).....	1
—	900164	Kit, pump service, (U-H1/U-HB) (Incls. Items 5, 6, 11, 13)	
—	900163	Kit, Pump service, (U-LD) (Incls. Items 5, 6, 11, 14)	

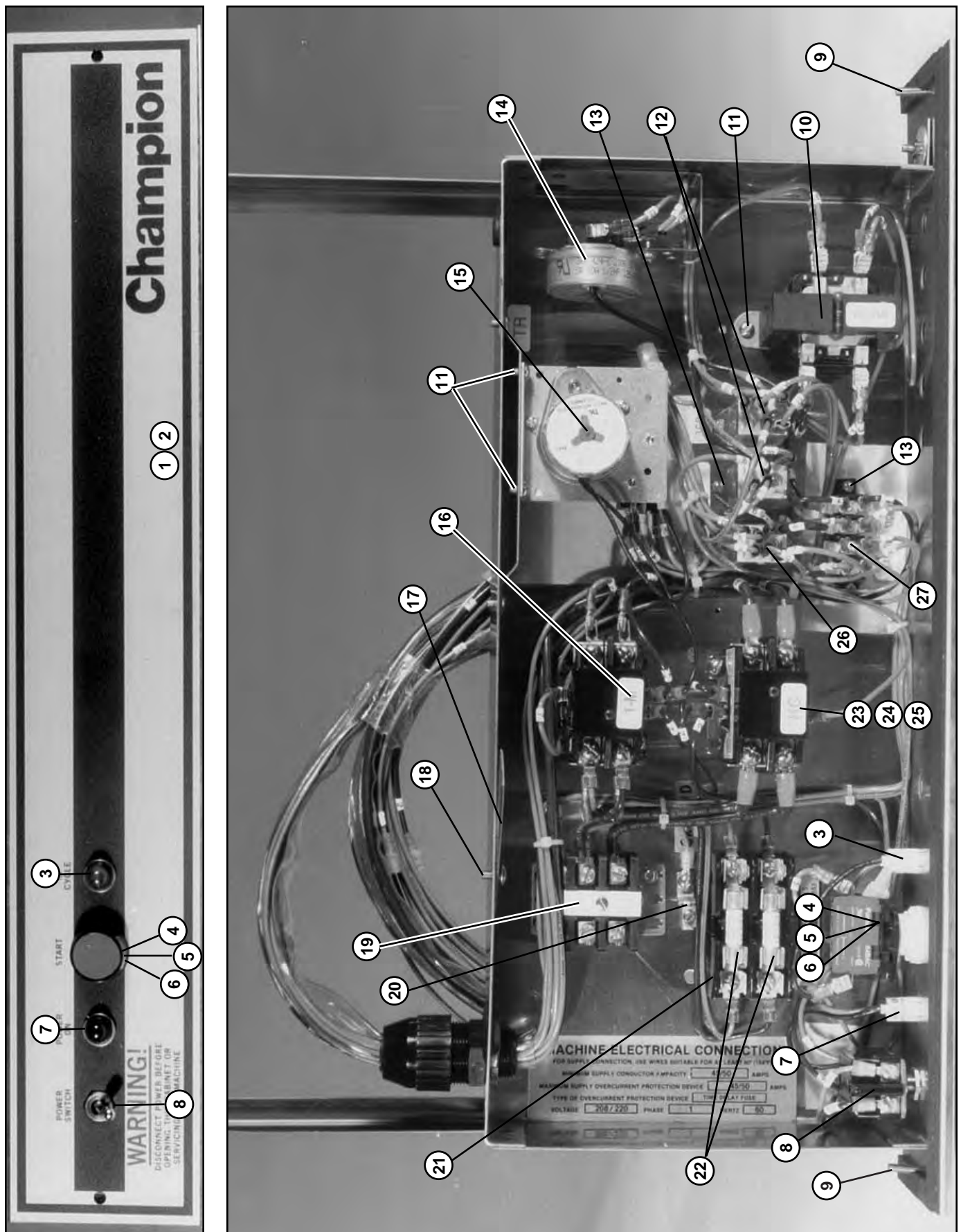

Figure 21 - U-H1/U-HB Control Cabinet

U-H1/U-HB CONTROL CABINET

Fig. 21 Item No.	Part No.	Part Description	Qty.
1	110274	Decal, faceplate (U-HB, U-H1)	1
2	110271	Decal, faceplate (U-LD).....	1
3	107365	Pilot, light (240V)(Green)	1
4	111614	Pushbutton (Green)	1
5	111617	Contact block (NO).....	1
6	900725	Kit, pushbutton (Incls items 4, 5)	1
7	101135	Pilot, light (240V)(Red)	1
8	107355	Switch, toggle (DPST on/off)	1
9	100097	Screw (10-32 x 1/2 Truss Hd).....	2
10	111238	Transformer (240V:24V).....	1
11	100095	Screw (10-32 x .375 Round Hd).....	14
12	111067	Relay (24V).....	2
13	104883	Screw (6-32 x 3/8 Round Hd).....	12
14	111467	Timer, fill.....	1
15	110302	Timer, cycle (90 sec.).....	1
16	107370	Contact, motor (208-240V coil).....	1
17	311527	Stop, control cabinet	1
18	100073	Screw (1/4 x 20 x 1/2 Truss Hd).....	1
19	106963	Block, terminal (H-2).....	1
20	103309	Lug, wire	1
21	106402	Block, fuse (30A, 2 pole, 600V).....	1
22	107384	Fuse, TRM-20A (250V, time delay)	2
23	107370	Contact, motor (40° rise booster)(U-HB only)	1
*24	111703	Contact, motor (70° rise booster)(U-HB only)	1
**25	111072	Contact, motor (70° rise booster)(U-HB only)	1
26	111069	Relay (240V).....	1
27	107366	Board, terminal.....	1

Special Notes:

*Beginning with S/N 86149 and above,
70° rise booster contactor is located inside slide out control cabinet.

**Prior to S/N 86149 70° rise booster contactor
located in stainless steel enclosure on the rear center of machine base.

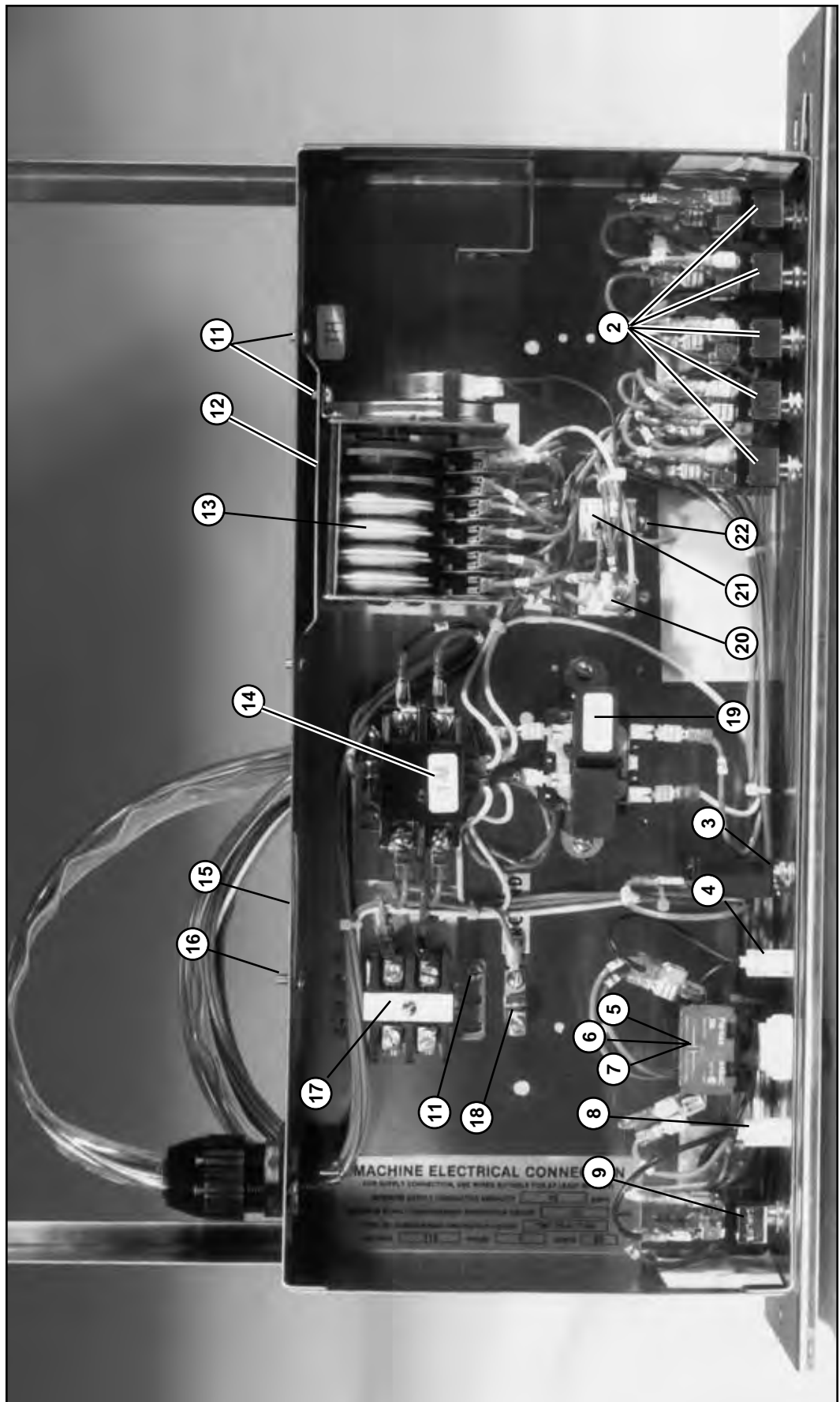
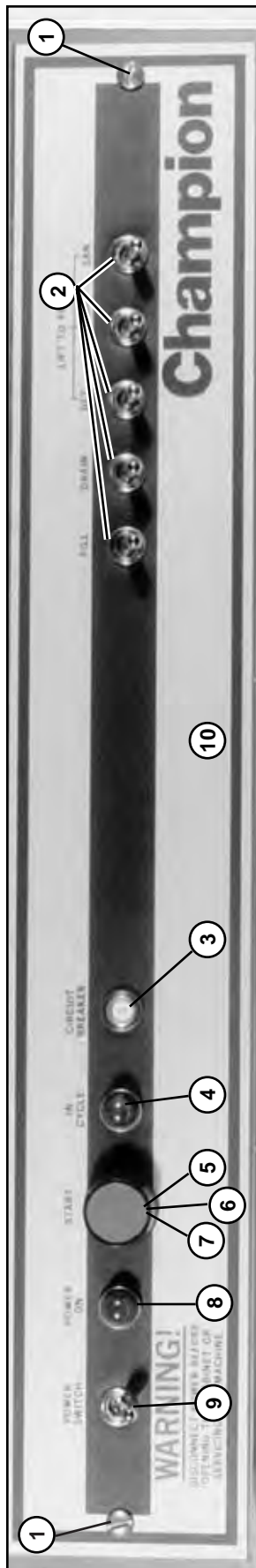

Figure 22 - U-LD Control Cabinet

U-LD CONTROL CABINET

Fig. 22 Item No.	Part No.	Part Description	Qty.
1	100097	Screw (10-32 x 1/2 Truss Hd).....	2
2	107150	Switch, toggle (On/Mom On, DPDT).....	5
3	106995	Circuit breaker (5 amp).....	1
4	106364	Pilot light (120V)(Green).....	1
5	111614	Pushbutton (Green)	1
6	111617	Contact block (NO).....	1
7	900725	Kit, pushbutton (Incls items 5-6)	1
8	101128	Pilot light (120V)(Red).....	1
9	107351	Switch, toggle (On/None/On DPDT).....	1
10	110271	Decal, faceplate (U-LD).....	1
11	100095	Screw (10-32 x .375 Round Hd).....	11
12	311346	Bracket, timer	1
13	109604	Timer (115V).....	1
14	107369	Contactor (25 FLA, 2 pole, 120V coil).....	1
15	311527	Stop, control cabinet	1
16	100073	Screw (1/4-20 x 1/2 Truss Hd).....	1
17	106963	Block, terminal (H-2).....	1
18	103309	Lug, wire	1
19	111277	Transformer (120V:24V).....	1
20	111068	Relay (120V).....	1
21	111067	Relay (24V).....	1
22	104883	Screw (6-32 x 3/8 Round Hd).....	4

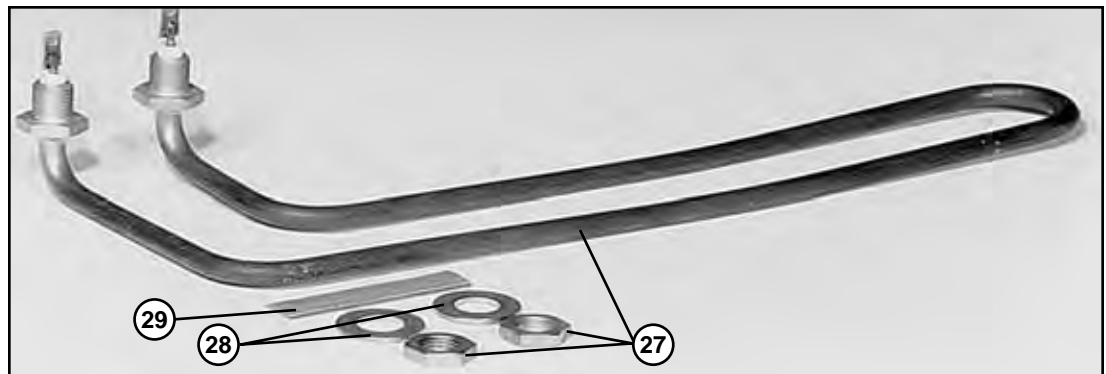
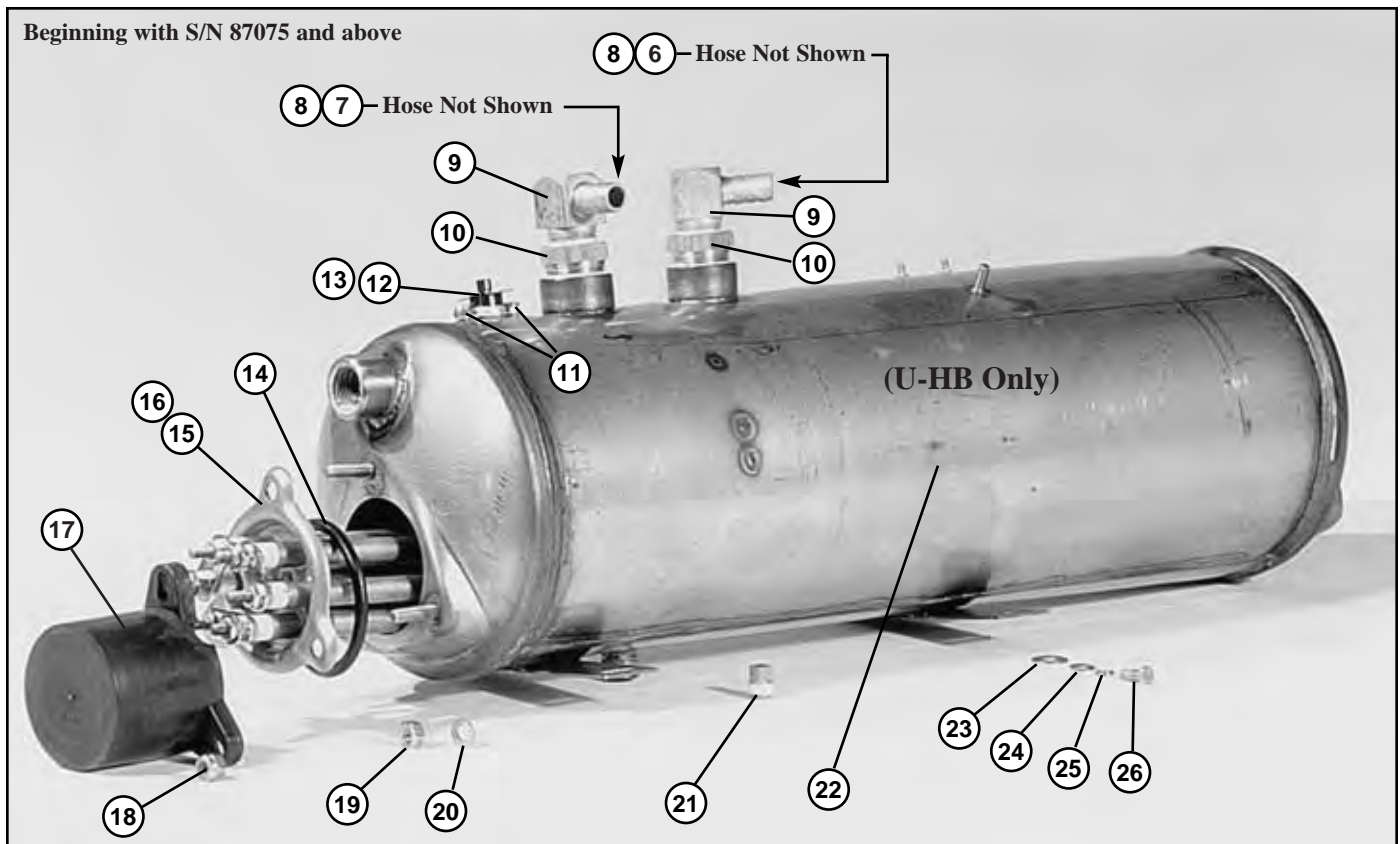

Figure 23 - U-H1/U-HB Thermostats, Booster Assembly, Wash Tank Element

**U-H1/U-HB
THERMOSTATS, BOOSTER ASSEMBLY, WASH TANK ELEMENT**

Fig. 23 Item No.	Part No.	Part Description	Qty.
1	109069	Thermostat, Wash tank (S/N 79001 thru 87723).....	1
1	112204	Thermostat, Wash tank (S/N 87724 thru 89896)..... <i>Replace with P/N 109069</i>	1
1	109069	Thermostat, Wash tank (S/N 89897 and above).....	1
2	109069	Thermostat, Booster tank, U-HB only (S/N 79001 thru 87723)...	1
2	112204	Thermostat, Booster tank, U-HB only (S/N 87724 thru 89896) ... <i>Replace with P/N 109069</i>	1
2	109069	Thermostat, Booster tank, U-HB only (S/N 89897 and above) ...	1
3	110561	Thermostat, high limit (Wash tank).....	1
4	201029	Locknut, 1/2" (For items 1,2,3)	3
5	104889	Compound 440 (Grey putty).....	1ft.
6	107417	24" hose (1/2" ID)(Booster to vacuum breaker)	1
7	107417	12" hose (1/2" ID)(Booster to manifold).....	1
8	111750	Clamp, hose (Not shown)	2
9	108528	Barb, hose (1/2 x 1/2 NPT 90° Brass).....	2
10	102392	Bushing, reducing (3/4 x 1/2 Brass)	2
11	108954	Nut, grip (6/32 w/nylon insert)	2
12	110562	Thermostat, fixed (Snap)	1
13	110563	Compound, heat sink	1
14	109985	O-ring	1
15	107909	Heater, booster tank (40° rise booster)	1
16	111334	Heater, booster tank (70° rise booster)	1
17	107908	Cover, heater	1
18	107967	Nut, grip (1/4-20 w/nylon insert).....	3
19	100003	Nut, plain (1/4-20 SST)	3
20	106482	Washer, lock (1/4 Split)	3
21	100210	Plug (1/8" SST).....	1
22	0508779	Tank, booster (Beginning with S/N 76701 thru S/N 87074).....	1
22	0509042	Tank, booster (Beginning with S/N 87075 & above)	1
23	106026	Washer (1/4 x 5/8 x 1/16 SST)	2
24	107033	Washer (.208 x .437 x .047).....	2
25	106486	Washer, lock (#10 Split)	2
26	111478	Bolt (10-32 x 1/2 Hex w/loctite)	2
27	110216	Heater, wash tank.....	1
28	104882	Washer (1/2 x 1 1/16 x 1/16)	2
29	104889	Compound 440 (Grey putty).....	1ft.

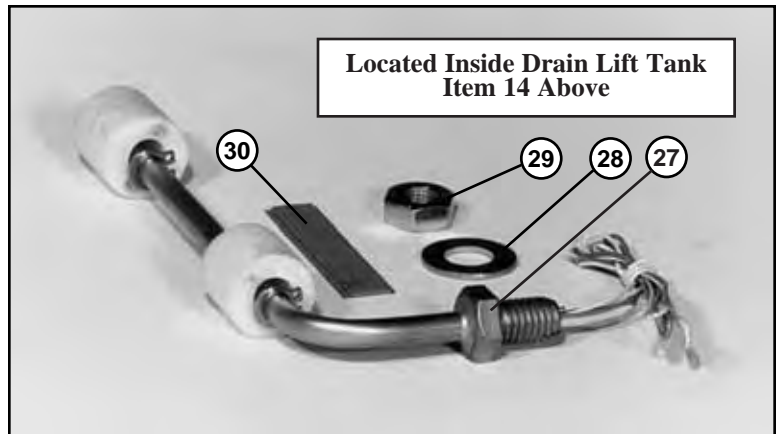
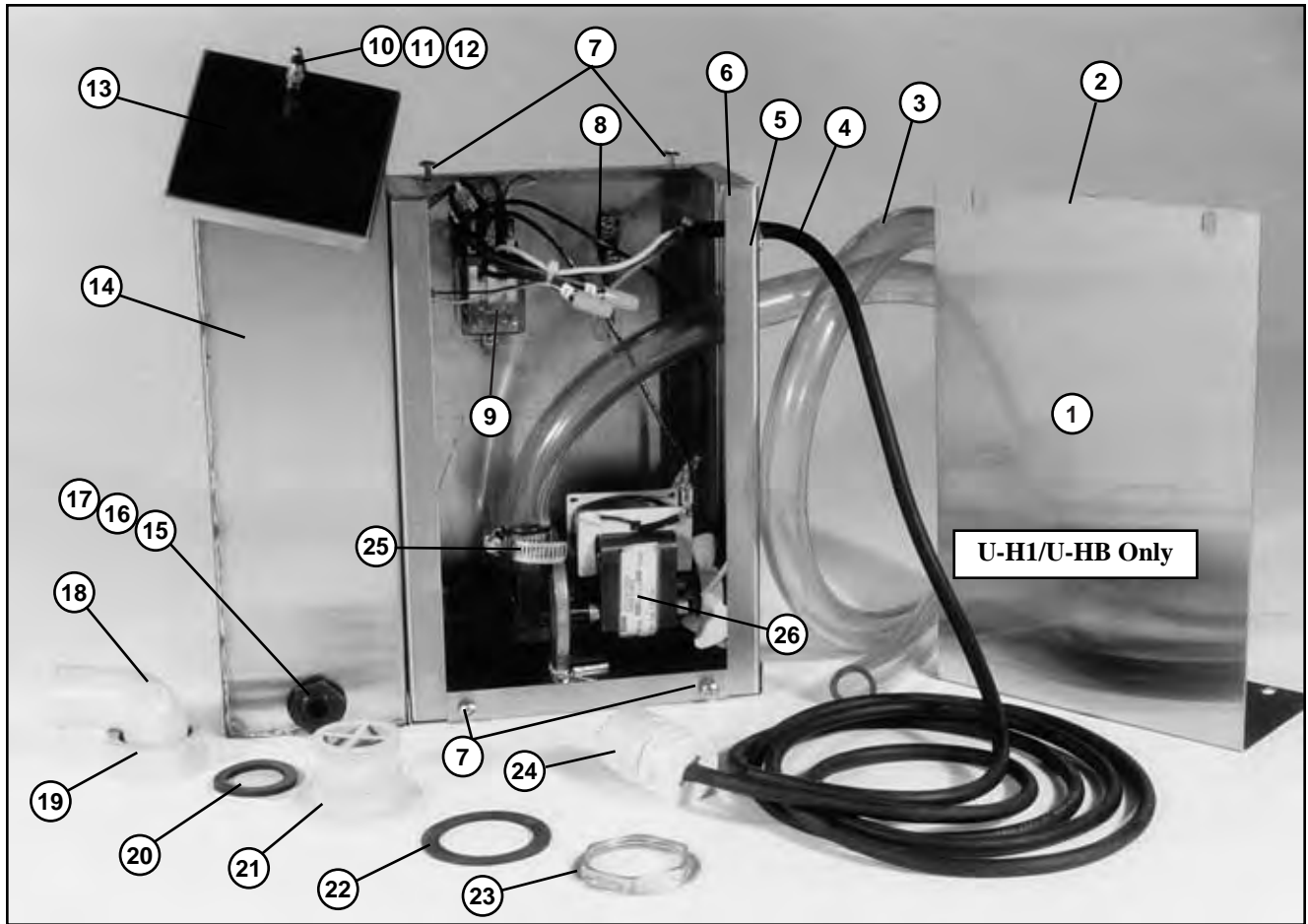

Figure 24 - U-H1/U-HB/U-LD Drain Lift Kits (Optional)

**U-H1/U-HB/U-LD
DRAIN LIFT KITS
(Optional)**

Fig. 24 Item No.	Part No.	Part Description	Qty.
1	403898	Kit, pumped drain lift (Complete)(U-H1/U-HB only).....	1
2	309673	Cover, cabinet.....	1
3	110067	Tubing (3/4 ID x 1 1/16 OD).....	5 ft.
4	107777	Connector (1/2" Romex)(Not shown).....	1
5	106068	Cord (SJ 16-3).....	10 ft.
6	309671	Cabinet.....	1
7	100097	Screw (10-32 x 1/2 Truss Hd).....	4
8	103309	Lug, wire.....	1
9	104709	Relay (120V).....	1
10	106481	Nut, acorn (10-32).....	1
11	107368	Coupling, chain (#10).....	1
12	107367	Chain, bead (#10).....	2 ft.
13	309674	Cover, tank.....	1
14	309677	Tank.....	1
15	108418	Plug (1/2").....	1
16	108417	Nut (1/2").....	1
17	109034	Washer, fiber (13/16 x 1 1/16).....	1
18	109284	Tailpiece, elbow.....	1
19	107867	Nut, outlet pipe.....	1
20	107866	Washer, packing.....	1
21	107863	Outlet, pipe.....	1
22	107864	Washer, packing.....	1
23	107865	Locknut.....	1
24	106464	Plug, yellow.....	1
25	105993	Clamp, hose.....	1
26	110065	Pump, centrifugal (115V).....	1
27	111116	Float switch, dual.....	1
28	104882	Washer (1/2 x 1 1/16 x 1/16).....	1
29	107089	Nut, jam (1/2-13).....	1
30	104889	Compound 440 (Grey putty).....	1 ft.
31	403801	Kit, drain lift (U-LD only).....	1

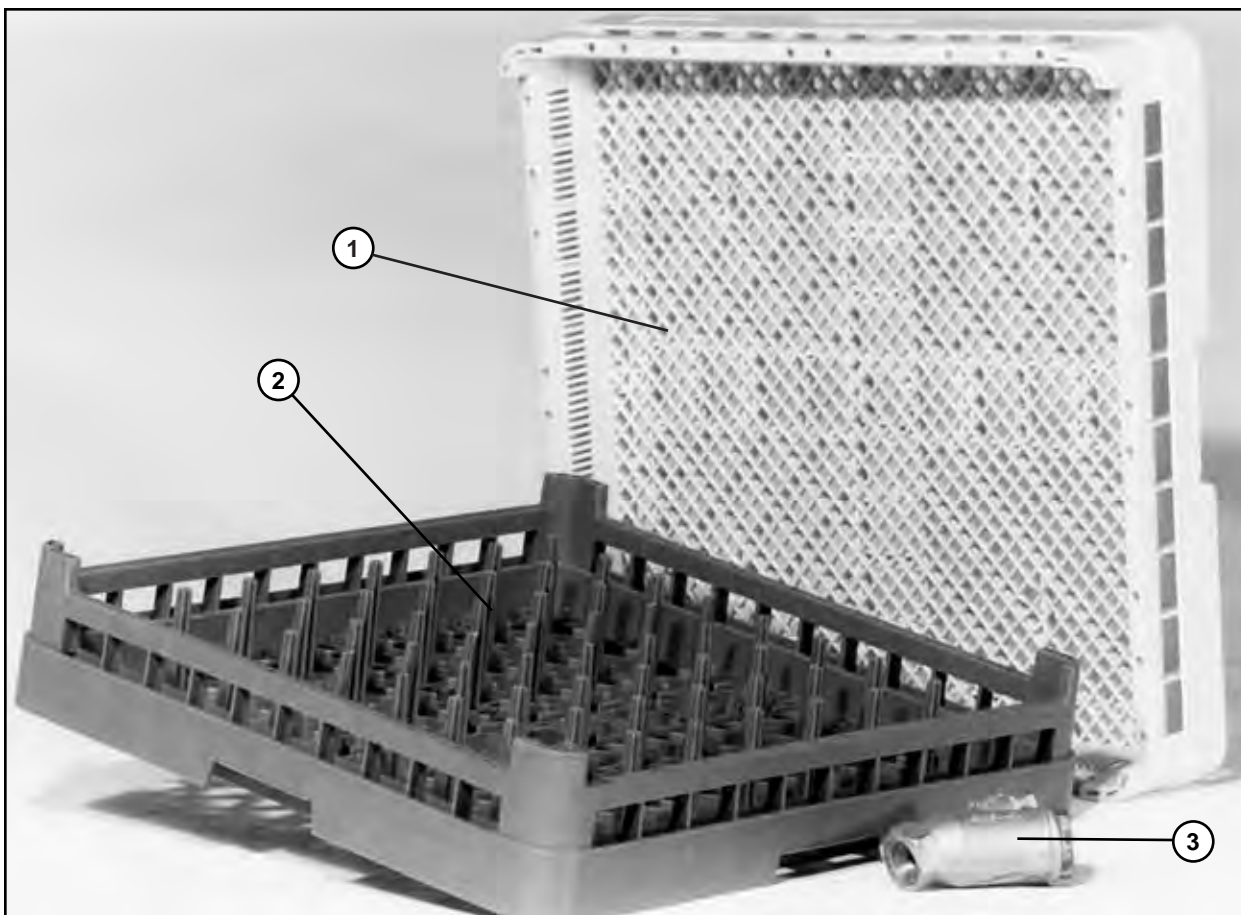

Figure 25 - Dishracks, Strainer, PRV

U-H1/U-HB/U-LD
Dishracks, Strainer, PRV

Fig. 25 Item No.	Part No.	Part Description	Qty.
1	101273	Rack, silverware (Flat bottom).....	A/R
2	101285	Rack, dish (Peg)	A/R
3	110768	Strainer, line (3/4" Brass) (Optional).....	1
4	107550	Valve, pressure regulating (3/4") (Optional).....	1

U-H1/U-HB

TO CUSTOMERS DISCONNECT SWITCH

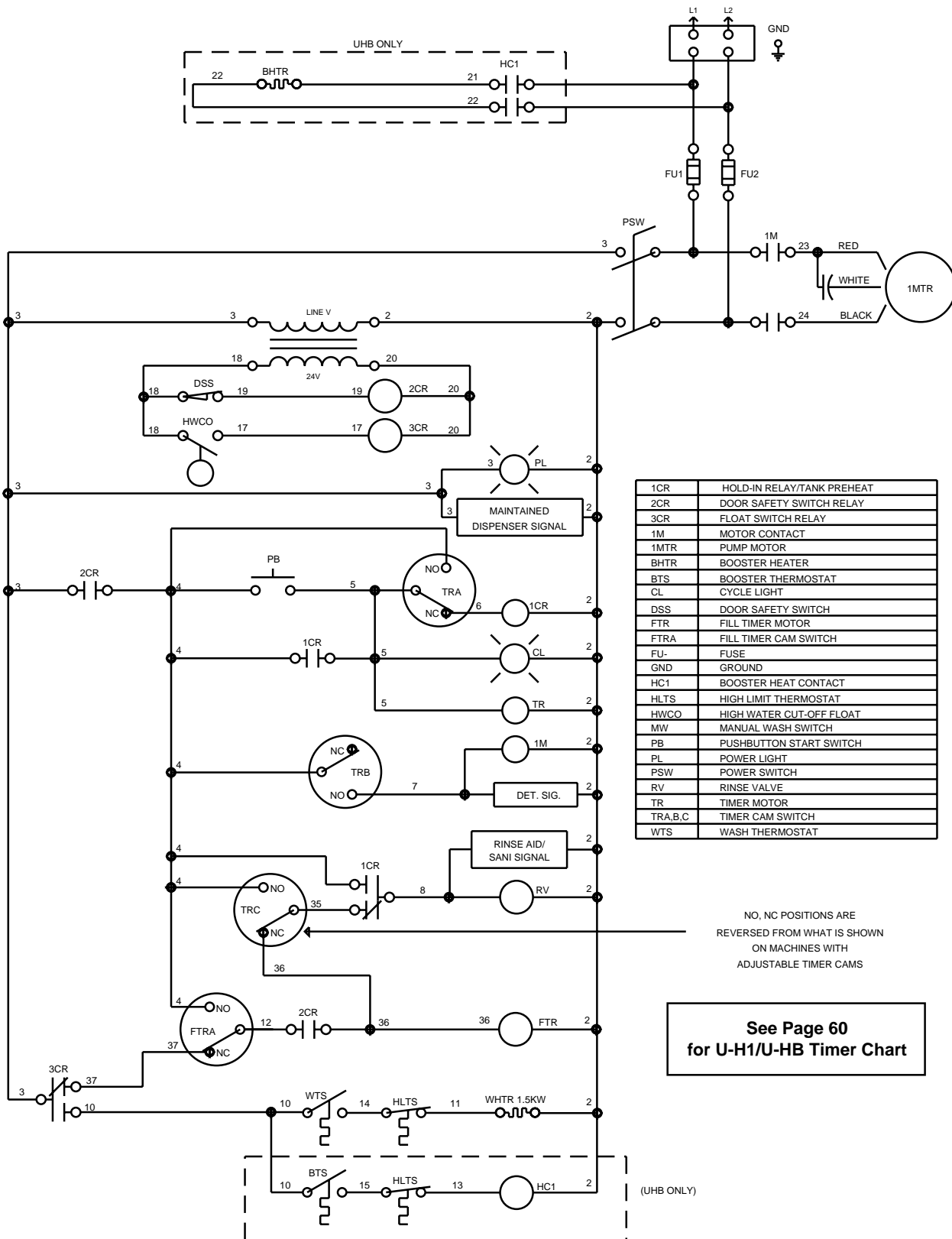
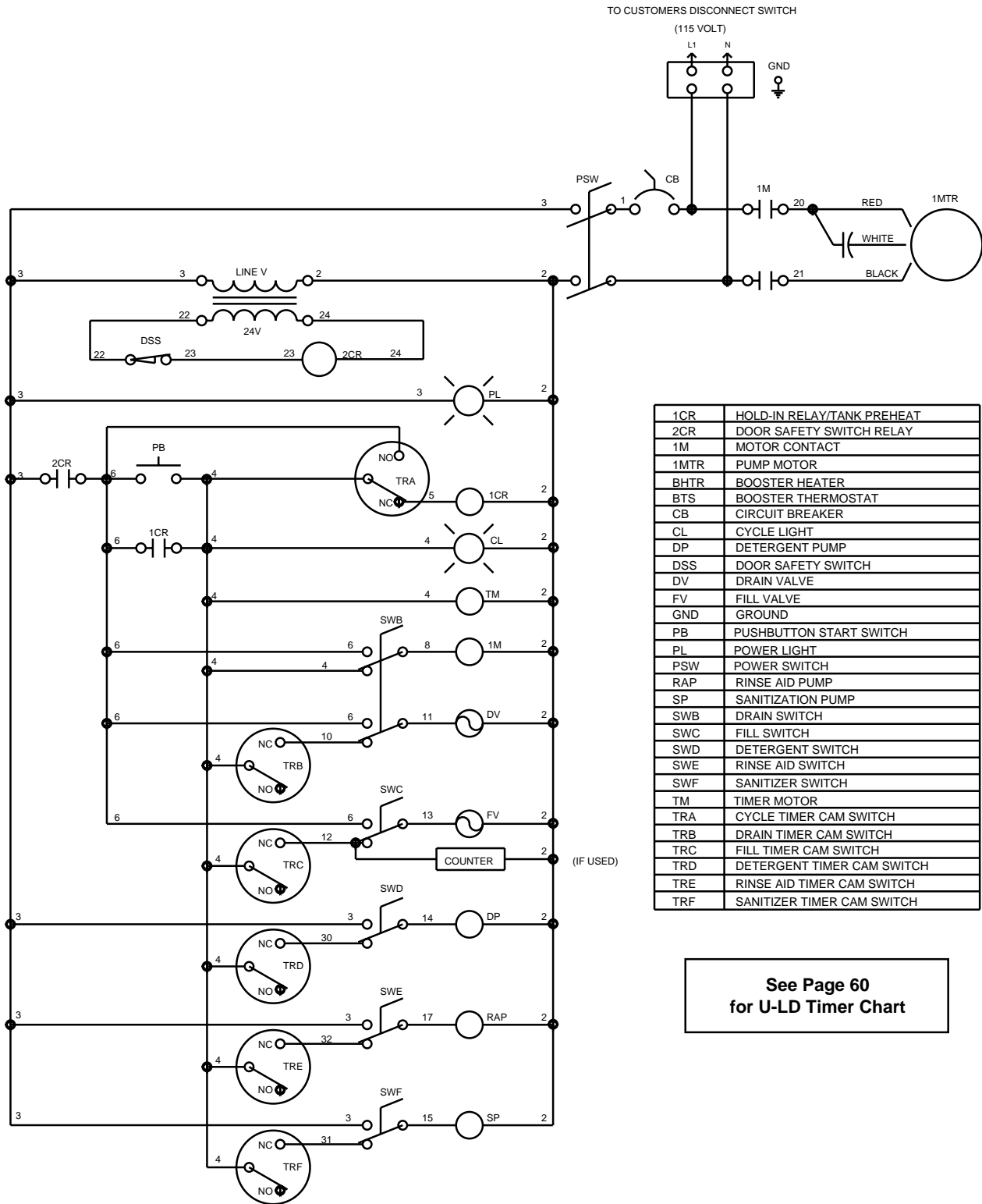

Figure 26 - U-H1/U-HB Electrical Schematic

C752517B

U-LD



See Page 60
for U-LD Timer Chart

Figure 27 - U-LD Electrical Schematic

C700918A

**U-H1/U-HB
Timer Chart**

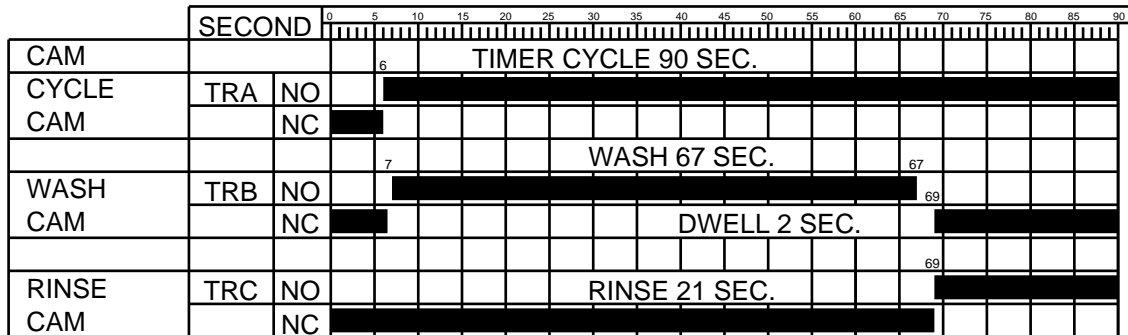

**U-LD
Timer Chart**

