

nexus[®]

by **MOYER DIEBEL**

Installation/Operation Manual with Service Replacement Parts



Model N900

Undercounter Dishwasher

N900
High Temperature Wash and
Drain with built-in booster
and Pumped Final Rinse



Issue Date: 22.08.23

Manual P/N 0514004 Rev. E

For machines beginning with S/N W190688229 and above

National Service Department

In Canada:

Toll-free: (800) 263-5798

Tel: (905) 562-4195

Fax: (905) 562-4618

email: service@moyerdiebellimited.com

In the USA:

Toll-free: (800) 858-4477

Tel: (336) 661-1556

Fax: (336) 661-1660

email: service@moyerdiebel.com

ATTENTION

The model no., serial no., voltage, Hz and phase are needed to identify your machine and to answer questions.

The machine data plate is located on the right front corner of the lower panel.

Please have this information ready if you call for service assistance.

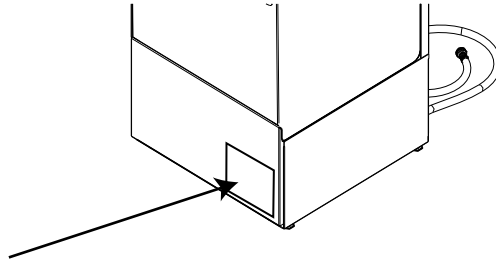



PRODUCT REGISTRATION ONLINE

Connect to the internet and enter the URL below to register your machine.

IN CANADA:

<https://www.moyerdiebel.com/warranty-registration>

nexus[®]

by **MOYER DIEBEL**

PRODUCT REGISTRATION BY FAX

COMPLETE THIS FORM AND FAX TO:

1 (800) 204-0109 in Canada

PRODUCT REGISTRATION CARD

Model

Serial #

Date of Installation: ___/___/___

Company Name: _____

Address: _____
(Street)

Telephone #: () _____ -- _____
State or Province Zip or Postal Code

Contact: _____

Installation Company: _____

Address: _____

Telephone #: _____

Contact: _____

FAILURE TO REGISTER YOUR PRODUCT MAY VOID YOUR WARRANTY

IMPORTANT IMPORTANT

Revision History

Specifications are subject to change based on continual product improvement.

Revision Date	Revised Pages	Serial Number Effectivity	Revision Description
7.26.19	All	W190688229	Released first edition
9.27.19	45	W190990970	Revised front and rear panels
4.21.21	36-37	All	Added detergent pump squeeze tube, Item 14, P/N H35137.
	38-39	All	Revised Item 9, to P/N 0713985, Control Board Kit.
	52-53	All	Added pump and motor parts.
	56	All	Added Parameter Settings Instructions.
3.1.22	36-37	W2202105579	New Nexus machines are being built using new black 0513936 chemical pumps in place of D34358
10.11.22	All	W190688229	Wash relay, missing from page 32 item 9. P/N 0514162
07.07.23	2	ALL	Updated page to have sump fill line.
	8,9,11	W2306113905	New pump illustrations shown.
	13	W2306113905	Priming instructions updated based on new pump configuration.
	39	W2306113905	Pump bracket updated to: 0314124 Additional pump & squeeze tube added for detergent set up.
	41	W2306113905	Updated wiring harness: 0514121
	43	W2306113905	Item 1 was 0713971
	45	ALL	Item 10 was 0513969

Limited Warranty

LIMITED WARRANTY

Moyer Diebel Limited (herein referred to as Moyer Diebel, 2674 North Service Road, Jordan Station, Ontario, L0R 1S0 and 3765 Champion Blvd., Winston-Salem, NC 27105) warrants machines, and parts, as set out below.

WARRANTY OF MACHINES: Moyer Diebel warrants all new machines of its manufacture bearing the name Champion, Moyer Diebel and/or Nexus and installed within the United States and Canada to be free from defects in material and workmanship for a period of one (1) year after the date of installation or fifteen (15) months after the date of shipment by Moyer Diebel, whichever occurs first. Products shipped outside of United States and Canada do not have warranty. The warranty registration card must be returned to Moyer Diebel within ten (10) days after installation. Warranty registration must be submitted to Moyer Diebel within ten (10) days after installation either online at: <https://www.championindustries.com/warranty-registration>, or by fax on the form provided in the front of this manual if warranty card is not returned to Moyer Diebel within such period, the warranty will expire after one year from the date of shipment. Moyer Diebel will not assume any responsibility for extra costs for installation in any area where there are jurisdictional problems with local trades or unions. If a defect in workmanship or material is found to exist within the warranty period, Moyer Diebel, at its election, will either repair or replace the defective parts, machine or accept return of the machine for full credit. In the event that Moyer Diebel elects to repair, the labour and work to be performed in connection with the warranty shall be done by a Moyer Diebel "Authorized Service Agent" during regular working hours and will be covered at normal rates and any additional overtime rate will be at the responsibility of the equipment purchaser. Warranty is covered up to 50 miles or 80 km's of travel from a Moyer Diebel authorized service technician. If travel exceeds 50 miles or 80 km's, then the end user will be responsible for additional travel expense. Service calls initiated under warranty that are found to not contain any defects in materials or workmanship, will not be covered by Moyer Diebel. Defective parts become the property of Moyer Diebel. Use of non OEM replacement parts not authorized by Moyer Diebel will relieve Moyer Diebel of all liability in connection with its warranty. In no event will Moyer Diebel's warranty obligation exceed Moyer Diebel's charge for the machine. Models that come with a factory paid start-up will be limited to one visit. Machines found to have issues related to installation procedures, or delays of any kind, will not be covered by Moyer Diebel and the sole responsibility of the equipment purchaser.

The following are not covered by Moyer Diebel's warranty:

- a. Element tubes and/or squeeze tubes.
- b. Vacuum breakers.
- c. Replacement of fuses or resetting of overload breakers, or high limits.
- d. Adjustment of thermostats, or temperature controlling devices.
- e. Adjustment of clutches.
- f. Adjustments of water pressure(s).

- g. Adjustments of chemical pumps.
 - h. Opening or closing of utility supply valves or switching of electrical supply current.
 - i. Cleaning of valves, strainers, screens, nozzles, or spray pipes.
 - j. Performance of regular maintenance and cleaning as outlined in operator's guide.
 - k. Damages resulting from water conditions, accidents, alterations, improper use, abuse, tampering, improper installation, low voltage conditions, inadequate wiring, outdoor use, or failure to follow maintenance and operation procedures.
 - l. Wear on Pulper cutter blocks, pulse vanes, and auger brush.
 - m. Damages due to improper storage.
 - n. Special installations or applications, including remote locations, are limited in coverage by this warranty. Any installation that requires extra work, and/or travel, to gain access to the unit for service is the sole responsibility of the equipment purchaser.
- Examples of the defects not covered by warranty include, but are not limited to:**
1. Damage to the exterior or interior finish as a result of the above.
 2. Use with utility service other than that designated on the rating plate.
 3. Improper connection to utility service.
 4. Inadequate or excessive water pressure.
 5. Corrosion from foreign materials, water supplies, improper chemicals, or chemicals dispensed in excess of recommended concentrations.
 6. Failure of electrical components due to connection of chemical dispensing equipment installed by others.
 7. Leaks or damage resulting from such leaks caused by water quality, or the installer, including machine table connections or by connection of chemical dispensing equipment installed by others.
 8. Failure to comply with all local building codes.
 9. Damage caused by labor dispute.

WARRANTY OF PARTS: Moyer Diebel warrants all new machine parts produced or authorized by Moyer Diebel to be free from defects in material and workmanship for a period of 90 days from date of invoice. If any defect in material and workmanship is found to exist within the warranty period, Moyer Diebel will replace the defective part without charge.

DISCLAIMER OF WARRANTIES AND LIMITATIONS OF LIABILITY. MOYER DIEBEL'S WARRANTY IS ONLY TO THE EXTENT REFLECTED ABOVE. MOYER DIEBEL MAKES NO OTHER WARRANTIES, EXPRESS OR IMPLIED, INCLUDING, BUT NOT LIMITED TO, ANY WARRANTY OF MERCHANTABILITY, OR FITNESS OF PURPOSE. MOYER DIEBEL SHALL NOT BE LIABLE FOR INCIDENTAL OR CONSEQUENTIAL DAMAGES. THE REMEDIES SET OUT ABOVE ARE THE EXCLUSIVE REMEDIES FOR ANY DEFECTS FOUND TO EXIST IN MOYER DIEBEL DISHWASHING MACHINES AND MOYER DIEBEL PARTS, AND ALL OTHER REMEDIES ARE EXCLUDED, INCLUDING ANY LIABILITY FOR INCIDENTALS OR CONSEQUENTIAL DAMAGES.

Moyer Diebel does not authorize any other person, including persons who deal in Moyer Diebel dishwashing machines, to change this warranty or create any other obligation in connection with Moyer Diebel Limited dishwashing machines.

Table of Contents

Revision History	i
Limited Warranty	ii
Installation	1
Installation Codes	1
Receiving	1
Placement	1
Water Connection	2
Drain Connection	3
Electrical Connection	6
Booster Fill Procedure	10
Machine Start-up	11
Chemical Dispensing Pumps.....	11
Detergent and Rinse-aid Injection Points	12
Priming the Chemical Dispensing Pumps	11
Operation	14
Normal Wash Mode	14
Loading Dish Racks	15
Operational Display.....	17
Start-up Sequence.....	17
Sump Fill Level	18
Wash Cycle	18
Rinse Sentry.....	19
AutoClean Drain	19
Cleaning	20
Cleaning the Wash Tank	20
Cleaning the Wash Arms	21
Cleaning Scrap Screen and Sump Strainer	23
Deliming	24
Maintenance	24
Maintenance Schedules	24
Diagnostic Features.....	26
Sensor Fault.....	28
Parameter Settings.....	28
Service Parts	31
Electrical Schematic	54
Timing Chart.....	55
Parameter Settings Instruction Sheet.....	56

**This Page
Intentionally
Left Blank**

INSTALLATION CODES

The installation of the dishwasher must comply with all local electrical, plumbing, health and safety codes or in the absence of local codes, installed in accordance with the applicable requirements in the National Electrical Code, NFPA 70, Canadian Electrical Code (CEC), Part 1, CSA C22.1; and the Standard for Ventilation Control and Fire Protection of Commercial Cooking Operations, NFPA 96.

RECEIVING

- Inspect the shipping carton damage and report immediately.
- Inspect the shipment for accessories and items shipped with the machine.
- Compare the installation site utilities to ensure they are the correct size and location.

⚠ CAUTION: Be careful when moving the dishwasher to prevent damage.

PLACEMENT

1. The dishwasher can be installed as a free-standing unit or under a counter-top. The typical counter-top height in most locations is 34" [86cm].
2. It is highly recommended that the underside of the counter-top be clad in metal.
3. Under counter installations should provide storage space for the dishwasher chemical supply containers. Do not elevate the containers above the finished floor.
4. Chemical supply containers should be placed as close to the machine as possible and the chemical tubing taped to the back of the machine should be repositioned before permanently placing the machine.
5. Place the dishwasher in its permanent location.
6. The dishwasher has 4 adjustable feet for leveling.
7. Level the dishwasher front-to-back and side-to-side.

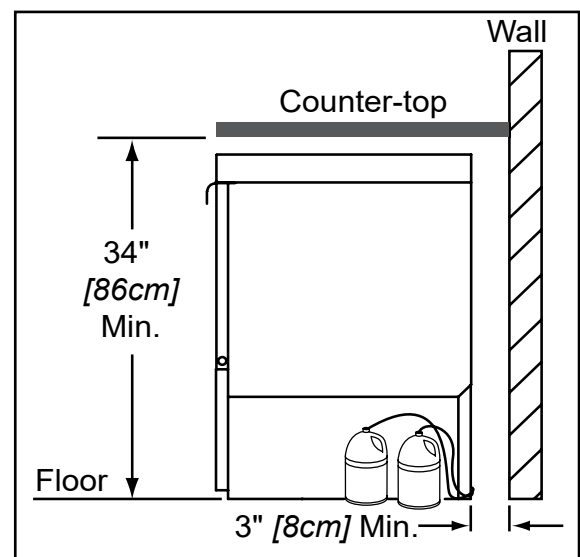

Fig. 1

Installation

WATER CONNECTION

NOTE:

The installation of the dishwasher must be performed by a qualified service personnel familiar with food service equipment. Problems due to improper installation are not covered by the Limited Warranty.

The installation of the dishwasher must comply with all local electrical, plumbing, health and safety codes or in the absence of local codes, installed in accordance with the applicable requirements in the National Electrical Code, NFPA 70, Canadian Electrical Code (CEC), Part 1, CSA C22.1; and the Standard for Ventilation Control and Fire Protection of Commercial Cooking Operations, NFPA 96.



CAUTION: Plumbing connections must be made BEFORE the electrical connections. Damage to water heaters will occur if the power is turned on without an adequate water supply.



It is the installing plumber's responsibility to flush the incoming water line to remove debris before connecting to the machine. Failure to do so will void the warranty.

1. All models have a 6 ft. flexible hot water fill hose with a 3/4" female garden hose connector.
2. A 1/2" or larger main incoming supply line must be installed to the dishwasher.
3. A 1/2" or larger shut-off valve should be installed in the main water supply, as close to the dishwasher as possible for servicing.
4. A water hardness of 3 grains/gal (US) [5.3 mg/L] or less is recommended. Excessively hard water will negatively impact wash results.

THE NEXUS has a built-in flow control. The flowing incoming hot water supply must be between 25-95 psi. The hot water supply must provide a minimum 140°F/66°C measured at the dishwasher.



SUMP FILL LEVEL

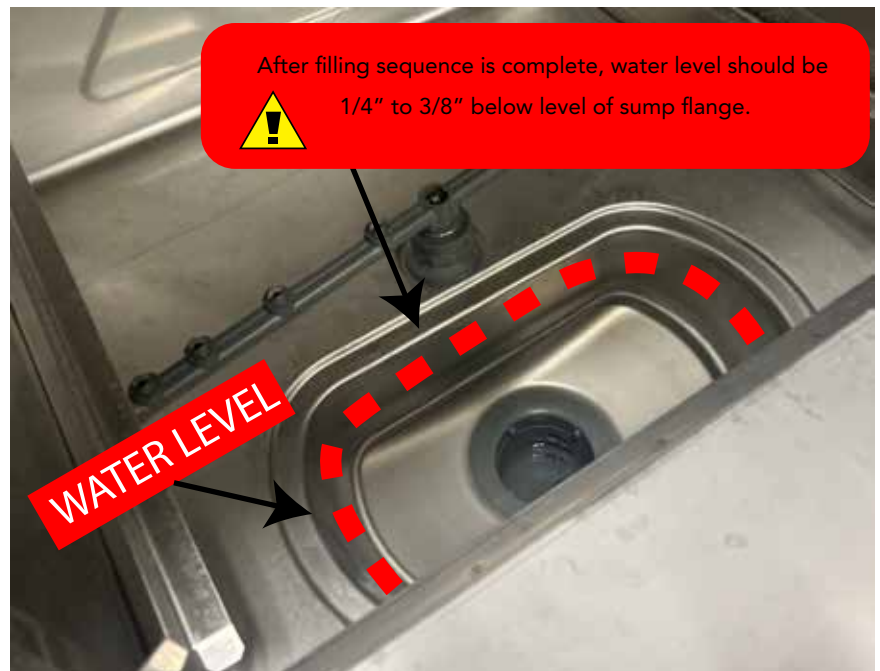
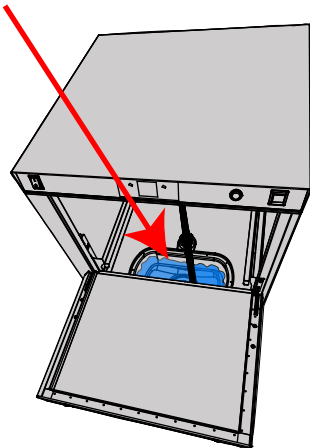

DRAIN CONNECTION

! VERY IMPORTANT !

The dishwasher will not drain correctly if it is connected to a disposer.

THE DRAIN HOSE IS LOOPED AND CLAMPED AND MUST NOT BE CHANGED. ALTERING THE DRAIN HOSE ROUTING MAY RESULT IN THE MACHINE'S INABILITY TO DRAIN OR MAY CAUSE THE MACHINE TO SIPHON THE WATER OUT OF THE MACHINE.

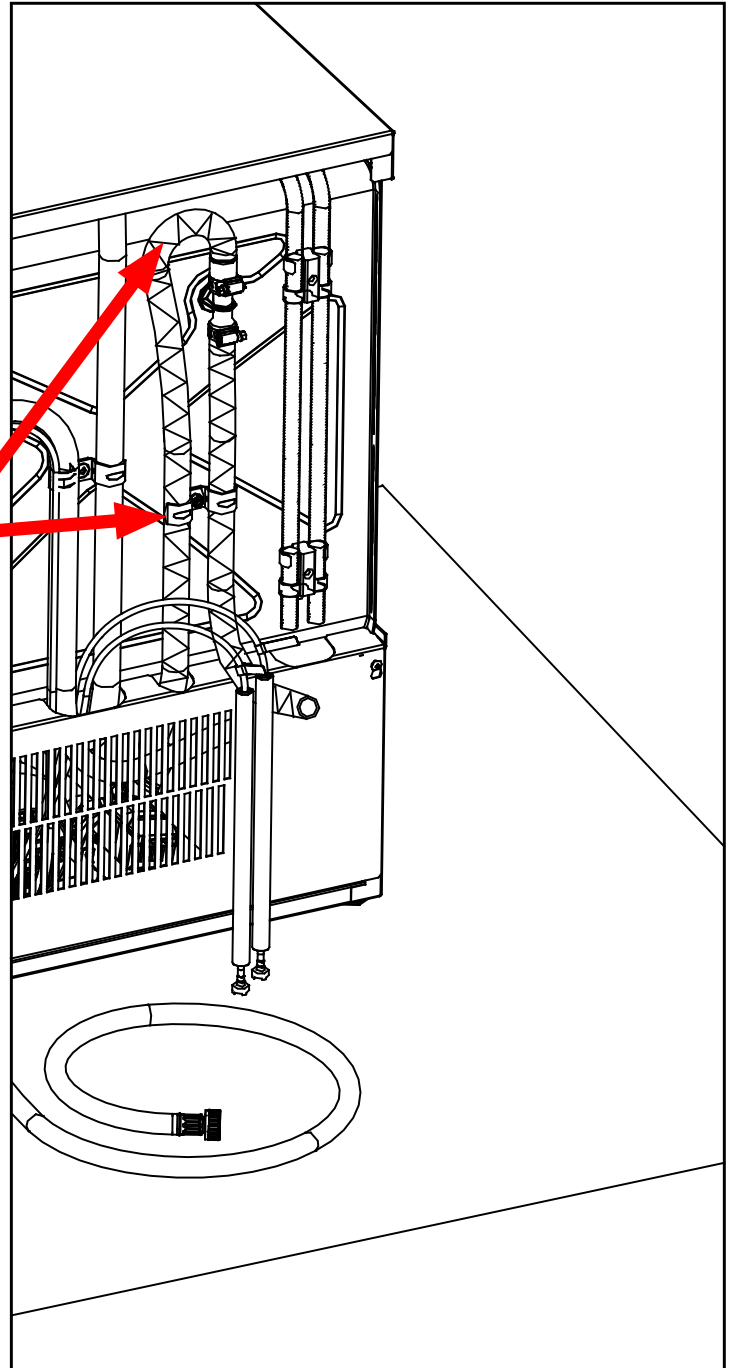

Installation

DRAIN CONNECTION (continued)

! ATTENTION !

Failure to follow the drain connection instructions may void the warranty.

1. Machine is equipped with a 6ft. [2m] 5/8" I.D. drain hose. The maximum drain height connection must not exceed 3ft. [1m] and must be vented to prevent wash tank siphoning.
2. Drain hose is located at the rear of the machine and is secured by two clamps to maintain the anti-siphoning loop in the drain hose.
3. A 3/4" hose barb fitting is strapped to the drain. The Hose Barb Fitting is P/N 0512321.
4. Additional parts are supplied by others.
5. The maximum drain flow is 15 US gpm/12.4 imp gpm, /60 lpm.

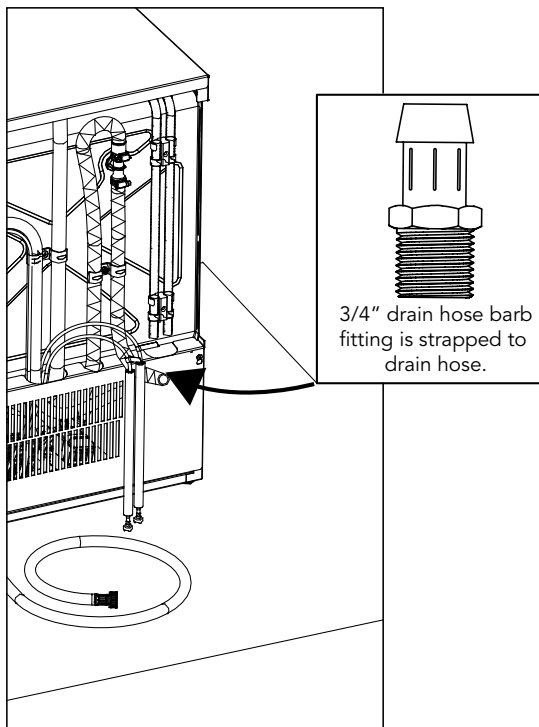

Fig. 2

DO NOT

- Do not remove the clamps holding the drain hose to the back of the machine.
- Do not connect the dishwasher to a disposer.
- Do not reduce the size of the drain hose connection or use a domestic drain fitting.
- Do not add additional length to the drain hose.
- Do not allow the drain hose to kink.

Building Drain Connection

1. Install the drain hose to an 1-1/2" or larger "WYE" fitting.
2. Building drain system must be properly vented.
3. **Connection to a "TEE" fitting will prevent the dishwasher from draining completely**

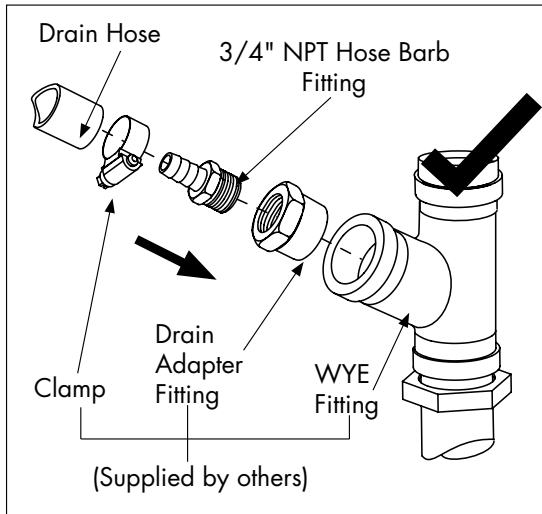

DO connect the flexible drain hose to a vented "WYE" connection.

Fig. 3

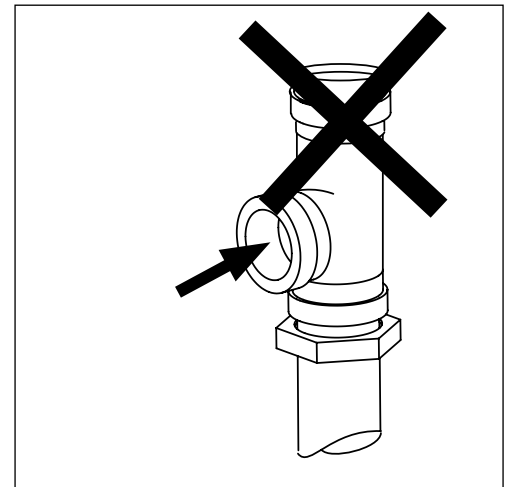

DO NOT
connect the flexible drain hose to a TEE fitting.

Indirect Drain Connection

1. A 1" (25.4mm) minimum air gap must be maintained between the outlet of the drain hose and the flood-level rim of the floor drain, floor sink, or any other locally approved drain receptacle (see Fig. 4).

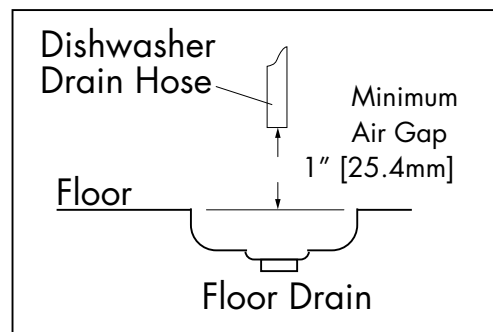

Fig. 4

! VERY IMPORTANT !

Drain problems are often due to improper installation of the drain hose and may not be covered by the limited warranty.

ELECTRICAL CONNECTION

Connect Power to the Main Terminal Block

NOTE:

The installation of the dishwasher must comply with all local electrical, plumbing, health and safety codes or in the absence of local codes, installed in accordance with the applicable requirements in the National Electrical Code, NFPA 70, Canadian Electrical Code (CEC), Part 1, CSA C22.1; and the Standard for Ventilation Control and Fire Protection of Commercial Cooking Operations, NFPA 96.

SINGLE PHASE POWER CONNECTION

The diagram shows three terminals labeled L1, L2, and GRD. L1 and L2 are connected to a 208-230 VAC supply, as indicated by a double-headed arrow between them. The GRD terminal is connected to a ground symbol.

! VERY IMPORTANT !

**THE ELECTRICAL POWER MUST BE A
2-WIRE PLUS GROUND SUPPLY.**

HOW TO CONNECT 1 PHASE POWER

1. Check the data plate on the front of the dishwasher for the phase of the machine.

If the data plate says the machine is 1 Phase,
then connect a 1 PH power supply.

2. Remove the lower access panel.
3. Pull power connection box forward and out.
4. The Main Terminal Block has connections for L1, L2 and Ground.
5. Connect ground, then connect L1, L2 to 208-230VAC.

DO NOT CONNECT POWER TO L3.

7. Main Power connections are complete.

nexus

ELECTRICAL CONNECTION

Connect Power to the Main Terminal Block



WARNING:

Electrocution may occur when working on energized circuits. Disconnect power at main breaker or service disconnect switch; lock out and tag to indicate work is being performed on the circuit.

! VERY IMPORTANT !

Provide a 3 feet/1 meter service loop in the power supply cable to service the machine.

! SINGLE PHASE POWER REQUIREMENT !

SINGLE PHASE NEXUS

The electrical power must be a 2-wire plus ground supply.

ELECTRICAL CONNECTION

Connect Power to the Main Terminal Block

1. Remove the lower front dishwasher panel (Fig. 5).

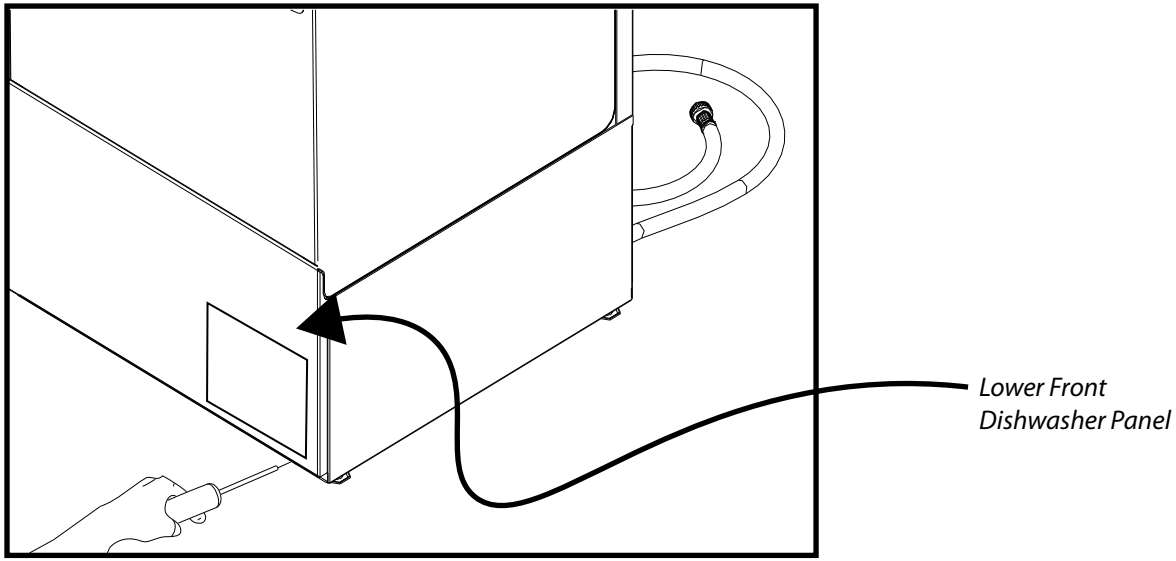

Fig. 5

2. Remove the retaining fastener (A) from the main terminal block (Fig. 6)

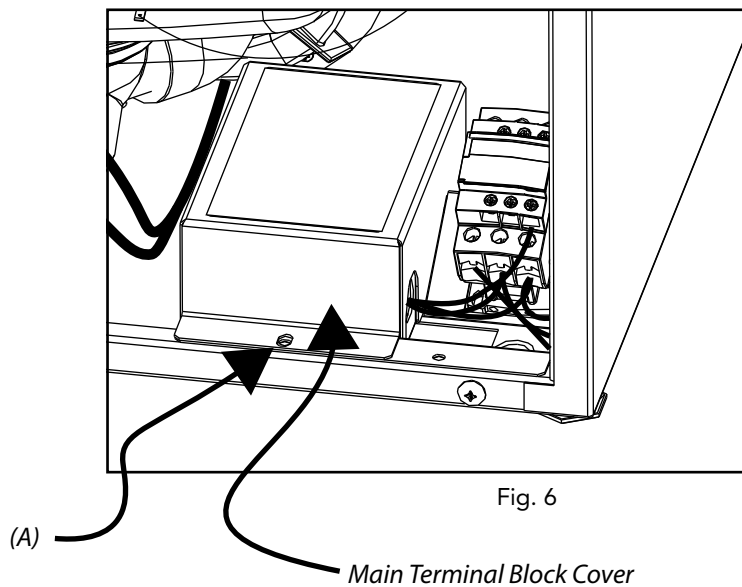

Fig. 6

(continued on next page)

ELECTRICAL CONNECTION

Connect Power to the Main Terminal Block

Refer to Fig. 7 below:

3. Provide a 3 foot/1 meter service loop in the machine power supply cable.
4. Route the power cable from machine rear to terminal block making sure the cable does not touch the booster tank.
5. Connect the power cable to the terminal block bracket using a suitable strain relief connector.
6. Connect the power wires according to the wiring diagram on page 6.

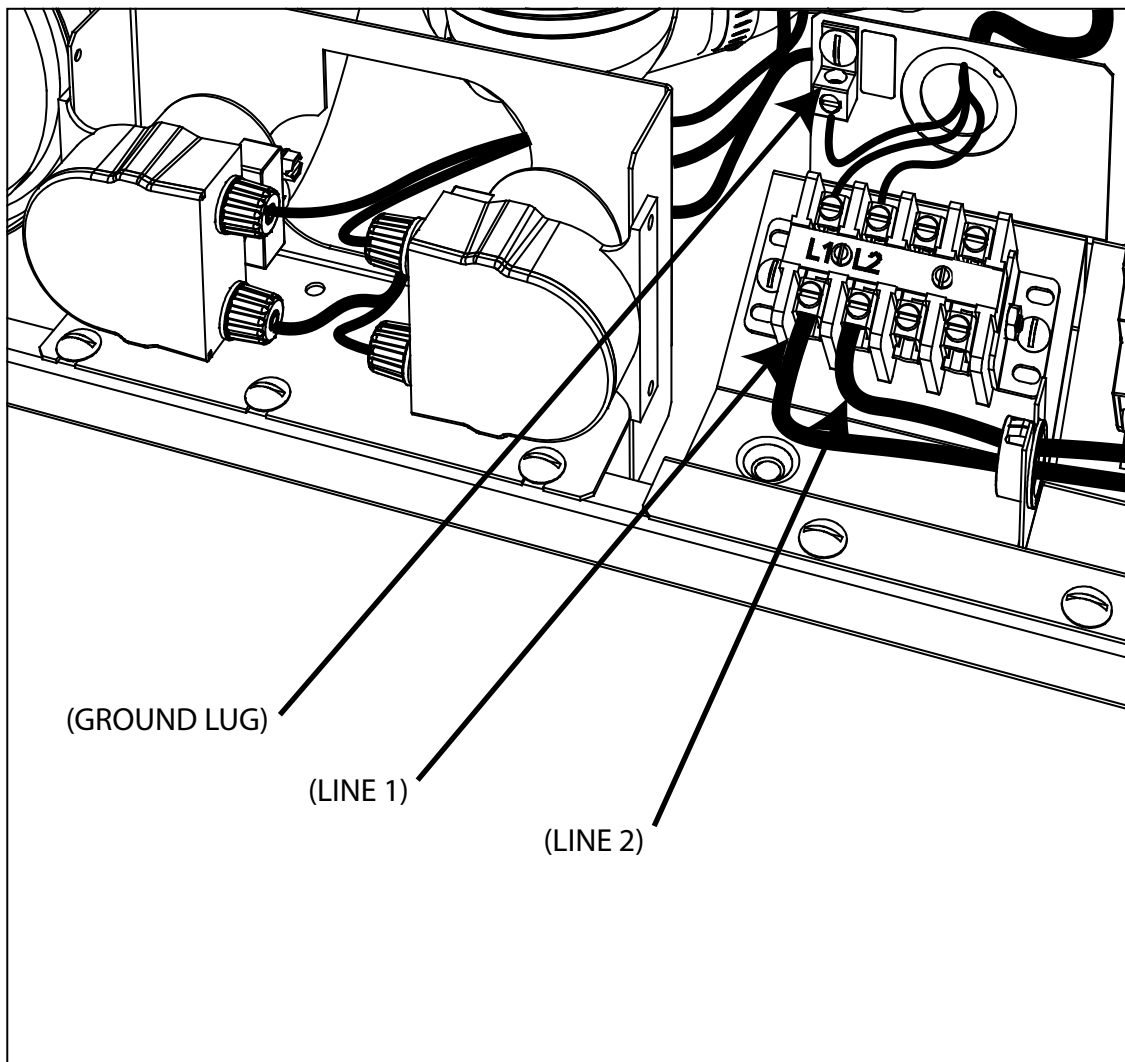

Fig. 7

BOOSTER FILL PROCEDURE

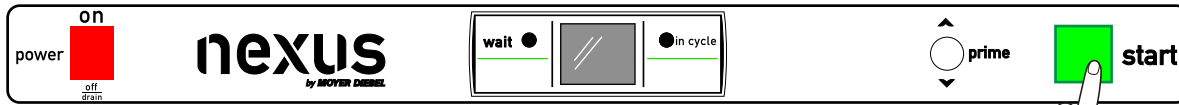

Fig.8

Follow the instructions to fill the booster tank prior to washing dishes.



1. **DO NOT TURN THE DISHWASHER POWER SWITCH ON**
2. Turn the main water supply to the machine ON.
3. Turn the main breaker or disconnect power switch ON.
4. Press and hold the dishwasher green start switch for three seconds to activate the fill solenoid.
5. Continue to hold the start switch until water enters the wash tank.
6. Release the green start button.
7. Booster pre-fill is complete.

MACHINE START-UP

Chemical Dispensing Pumps

! VERY IMPORTANT !

ALWAYS USE A COMMERCIAL GRADE NON-CHLORINATED DETERGENT.
PLACE THE CHEMICAL CONTAINERS AS CLOSE TO THE MACHINE AS POSSIBLE.
DO NOT ELEVATE THE CONTAINERS ABOVE THE FINISHED FLOOR

! VERY IMPORTANT !

Contact a chemical supplier for detergent and rinse-aid chemicals. The chemical supplier must adjust the chemical dispensing pumps for water hardness and food soil types.

1. The detergent and rinse-aid pumps are located at the lower left-side of the machine behind the lower panel.
2. Each pump is equipped with 6 feet/ 1.8 meter of pick-up tubing. The tubing consists of supply tubing, stiffener tube, and strainer.
3. The tubing is stowed on the back of the machine for shipping.
4. A red label marked DETERGENT and a blue label marked RINSE-AID, identify the lines.

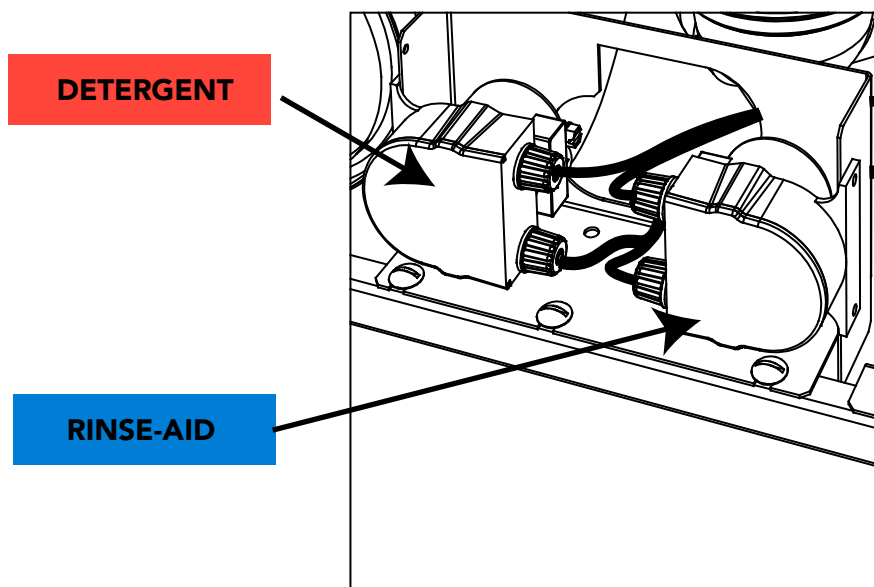

Fig. 12

Detergent and Rinse-aid Pump Injection Points

! VERY IMPORTANT !

**ALWAYS USE A COMMERCIAL GRADE NON-CHLORINATED DETERGENT.
PLACE THE CHEMICAL CONTAINERS AS CLOSE TO THE MACHINE AS POSSIBLE.
DO NOT ELEVATE THE CONTAINERS ABOVE THE FINISHED FLOOR**

Injection Point Locations

1. The detergent and rinse-aid enter the wash tank through a fitting located at the right-rear corner of the machine.

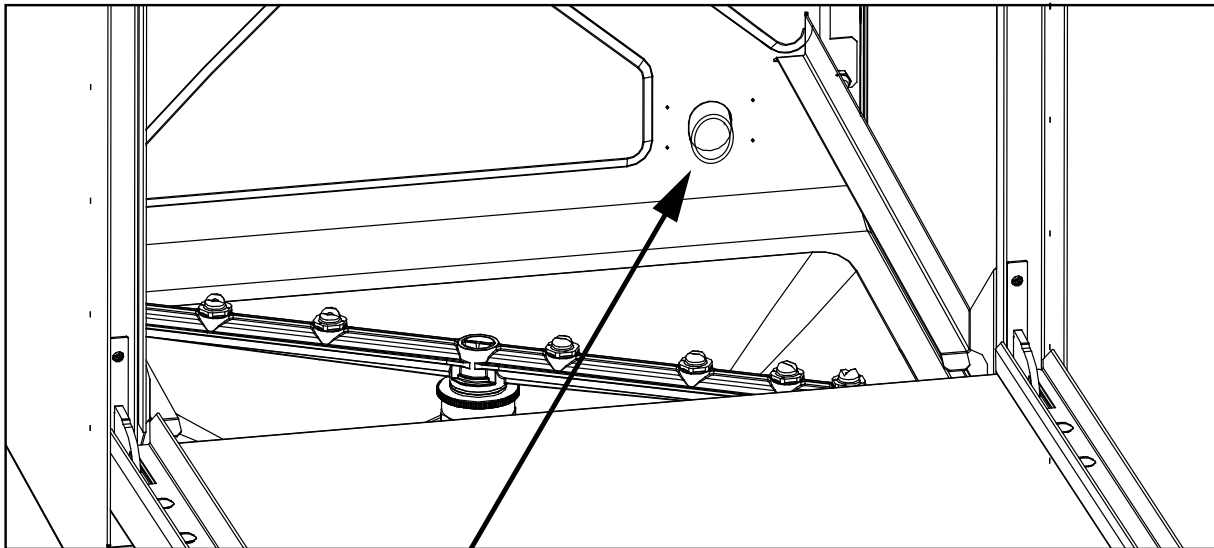

DETERGENT AND
RINSE-AID
INJECTION POINT

Fig. 13

Priming the Chemical Dispensing Pumps

! VERY IMPORTANT !

The chemical dispensing pumps must be primed before operating the dishwasher and whenever the container is changed.

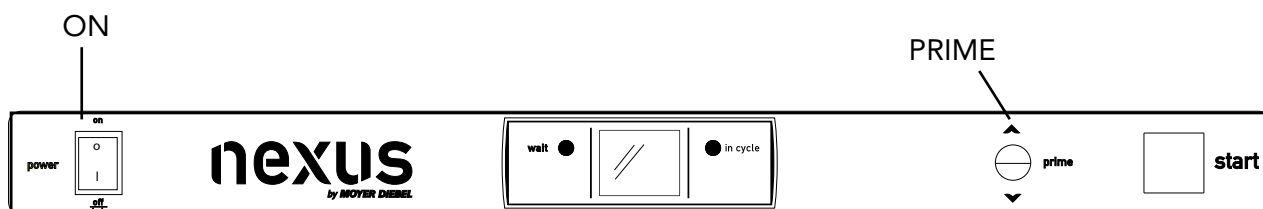

Fig.10

1. The chemical dispensing pump supply lines must be primed before the will pump properly.
2. Make sure the containers are full and the correct pick-up tubes are in their containers.
3. Turn the dishwasher power switch ON. The switch illuminates and the machine fills with water.
4. Open the dishwasher door, then push and hold the prime push button, (Fig. 11):

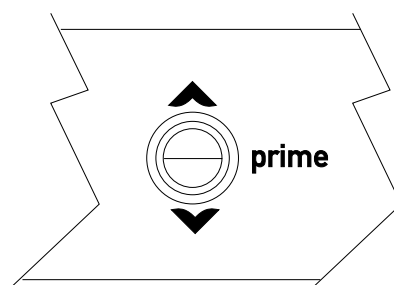



Fig.11

By pressing,UP  to the detergent position until detergent is observed entering the wash compartment from the injection fitting in the right rear of the tank. Release the button.

By pressing,down  to the rinse aid position until rinse aid is observed entering the wash compartment from the injection fitting in the right rear of the tank. Release the button.

! VERY IMPORTANT !

INSPECT AND REPLACE THE CHEMICAL DISPENSING PUMP SQUEEZE TUBES EVERY SIX MONTHS.

NORMAL WASH MODE

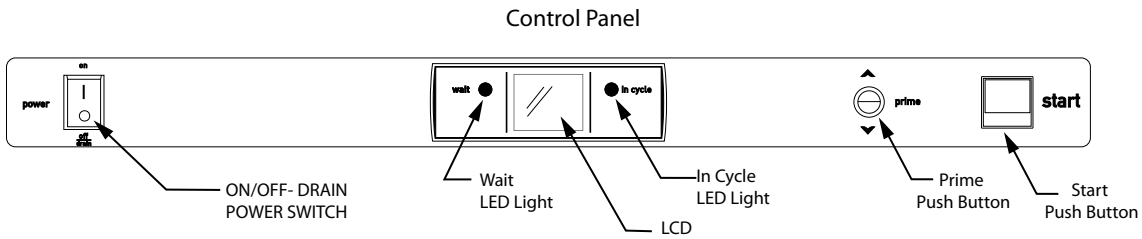

1. Close the door dishwasher front door.
2. Push the Power Switch UP to turn on power.
3. The power switch will illuminate and the machine will fill with water.
4. Wait until the wash temperature indicates a minimum of 150°F/66°C.

PLACE AN EMPTY DISH RACK IN MACHINE AND RUN FIRST CYCLE EMPTY TO HEAT WASH TANK INTERIOR.

5. Load the dish rack into the machine. Wash one dish rack at a time.
6. Close the door and press the green start button for 1 second. The green in-cycle light will illuminate and the cycle will begin.
8. The final rinse cycle begins at the end of the wash cycle. The machine drains and refills with fresh hot water. The final rinse must indicate a minimum of 180-195°F/82-92°C.
9. Open the door and remove the wares when the green cycle light goes out.

! ATTENTION !

RINSE SENTRY MODE WILL EXTEND WASH CYCLE TIME

In the event the final rinse temperature has not reached 180-195°F/82-92°C. After the wash cycle, the rinse sentry will extend the wash cycle time until the booster reaches 180-195°F/82-92°C. If the proper temperature is not reached within 5 minutes, the machine will leave the rinse sentry mode and complete the cycle.

LOADING DISH RACKS

! VERY IMPORTANT !
DO NOT OVERLOAD THE DISH RACK.
LOAD ONE DISH RACK INTO THE MACHINE AT A TIME.

1. Prescrap and rinse the wares before loading to remove large food particles.
2. Load soiled wares into the dish rack. Place plates and glasses in a peg rack. Place cups and bowls in an optional flat bottom rack. Place utensils in a single layer in a flat-bottom rack. Place pots and pans in a peg rack. Do not overload the dish rack. Wash one dish rack at a time.
3. Slide one dish rack into the wash compartment making sure that wares do not interfere with the rotating spray arms. Do not wash more than one dish rack at a time.

Prescrap and rinse wares before loading into the machine.

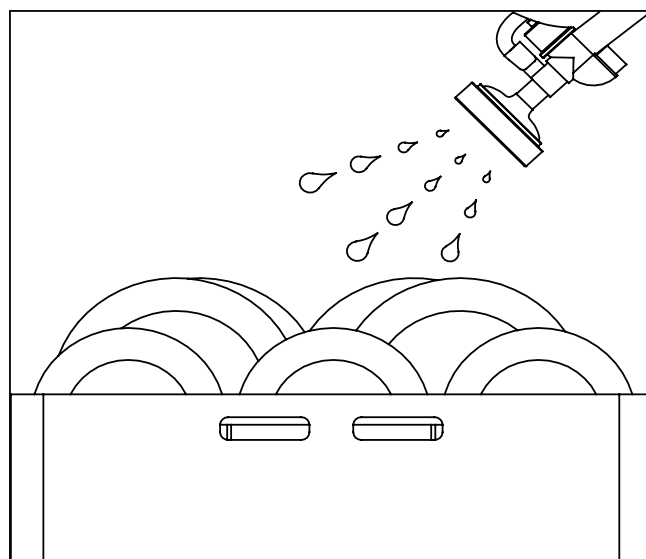

Load plates and glasses in a peg rack.

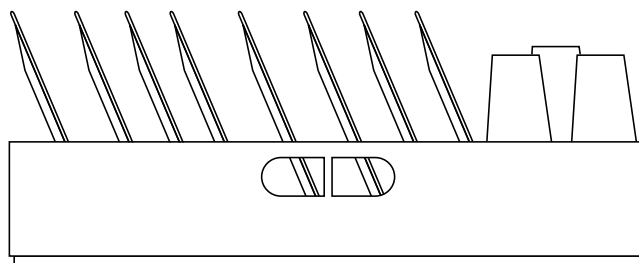

Operation

Loading Dish Racks

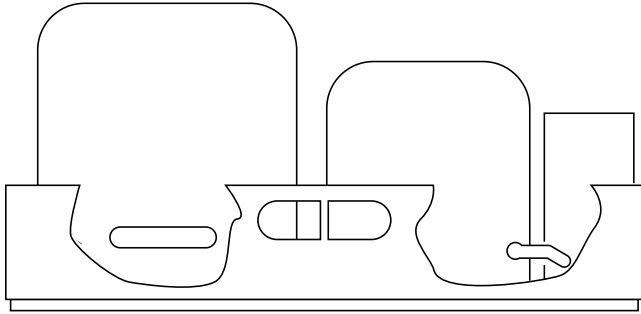

Load pots and pans in an
peg rack or optional flat-bottom rack.

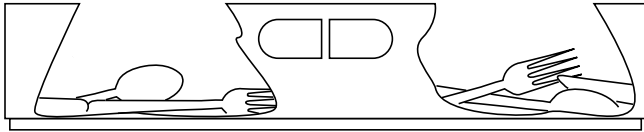

Load utensils in a single layer in a peg
rack or an optional flat-bottom rack.

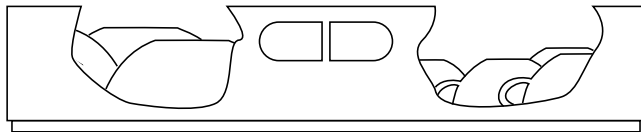

Load cups and bowls in a peg
rack or an optional flat-bottom rack.

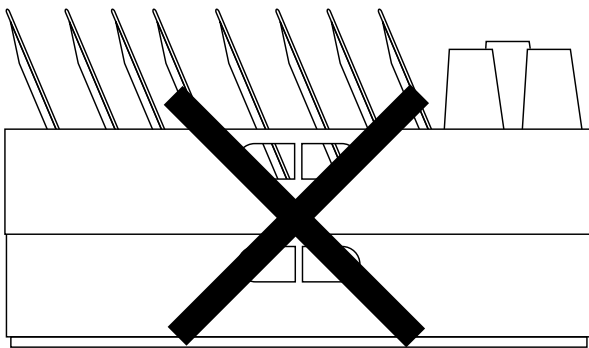

NEVER stack dish racks.
Wash one dish rack at a time.

OPERATIONAL DISPLAY

The screen displays the operational status of the machine throughout the cycle.

- **Start-up Sequence**



1. When power switch is turned ON, system information screen will show briefly.
2. This shows firmware version, parameter settings, and cycle counts.



1. Machine is filling.
2. Wait light is illuminated.
3. Progress bar shows fill time remaining.



1. Red thermometer indicator shows booster tank is heating.
2. Wait light remains illuminated.
3. Wait light indicates cycle is pending
4. Progress bar shows remaining heat time.



1. Booster heater has achieved temperature
2. Blue thermometer bar shows the wash tank heat is active.
3. Wait light is out and READY shows a cycle may begin.



1. Ready indicates the machine will wash.
2. 155°F indicates the wash tank temp.

Operational Display (continued)

WASH CYCLE



WASH

1. The status indicator shows cycle progress.
2. In-cycle light is illuminated.

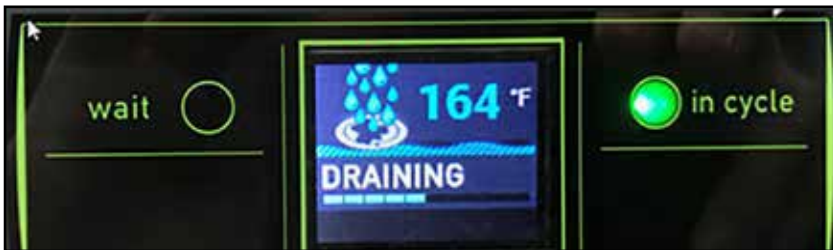

DRAIN

1. When the wash cycle is complete the machine will drain all of the water and refill with fresh hot water.



RINSE

1. Display changes to red and indicates rinse temp.

RINSE SENTRY



AUTOCLEAN DRAIN



1. When machine is turned off, the AutoClean screen with the status indicator is shown.



2. This takes approximately 2-1/2 minutes.

3. When complete, open door to allow machine interior to air dry.

Cleaning the Wash Tank

! VERY IMPORTANT !
DRAIN AND CLEAN THE DISHWASHER EVERY 2 HOURS OF CONTINUOUS OPERATION, AFTER EACH MEAL PERIOD AND AT THE END OF THE DAY.

1. Remove the upper and lower spray arms and flush clean with water.
2. Remove the scrap screen making sure food soils do not fall into tank.
3. Flush and back flush with clean water.
4. Check the sump.
5. Check the pump intake strainer.
6. Do not scrub the interior with metal pad.
7. Check the heating element for lime buildup and remove. Do not use a metal pad.
8. Wipe the exterior of the machine with a soft cloth and mild detergent.
9. Leave the door open to aid in overnight drying.

DO NOT USE METALLIC SCRUB PADS TO CLEAN THE MACHINE.
DO NOT SPRAY THE EXTERIOR OF THE MACHINE WITH WATER.

Cleaning the wash arms:

1. Unscrew the retaining screw from the upper and lower interchangeable spray arms
2. Flush the spray arms clean in a sink. Be sure to flush the wash arm bearings.

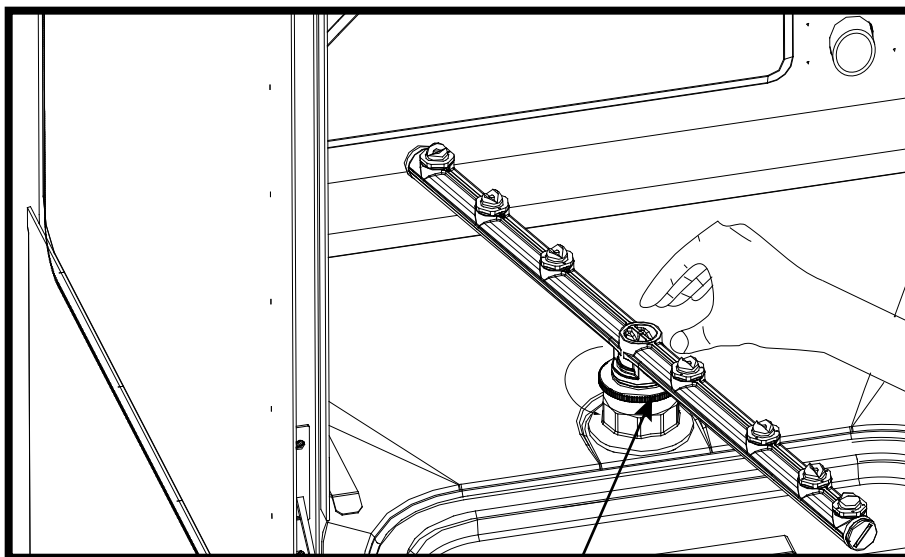

USE GROVES TO LOSEN
HUB FOR CLEANING.

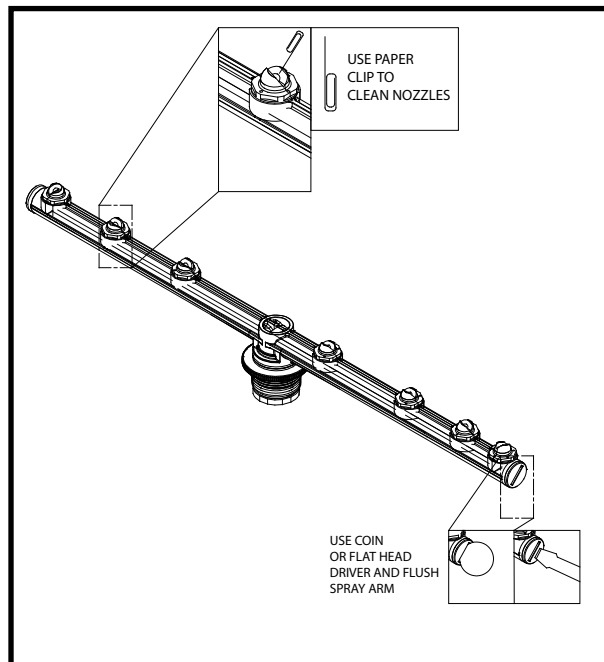
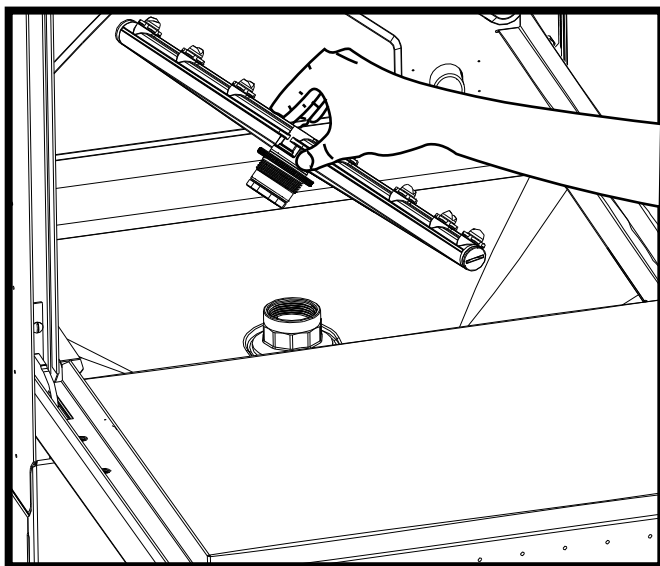

USE PAPER
CLIP TO
CLEAN NOZZLES

USE COIN
OR FLAT HEAD
DRIVER AND FLUSH
SPRAY ARM

Cleaning the Scrap Screen and Sump Strainer

1. Lift the scrap screen straight up and out of the machine to prevent food particles from falling into the tank sump.
2. Flush the scrap screen in a remote sink making sure to back-flush both side of the screen.
3. Wipe the tank sump of water and debris.
4. Carefully inspect the pump intake strainer. This strainer is not removeable but must be thoroughly cleaned before reinstalling the scrap screen.

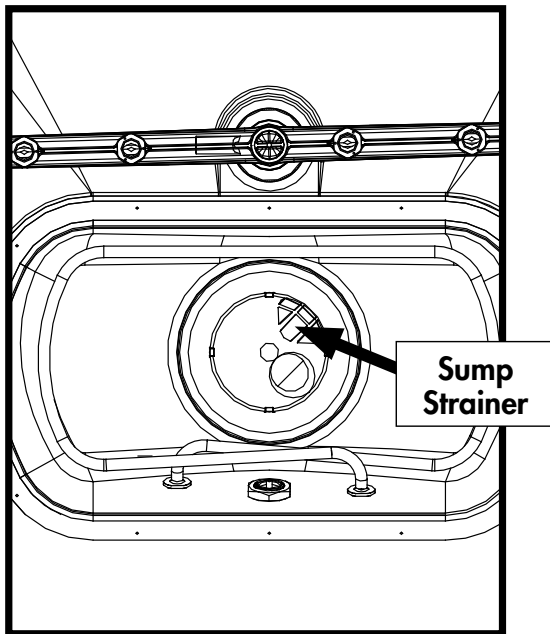
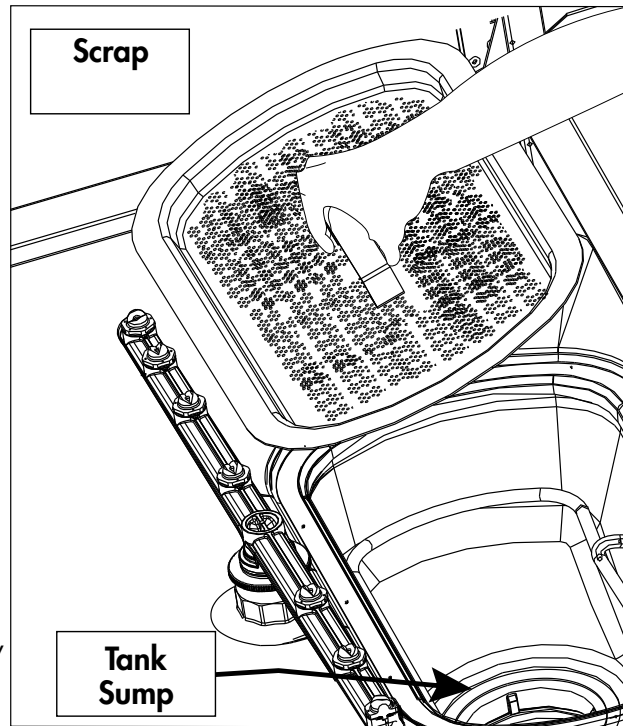

! ATTENTION !
A CLOGGED OR RESTRICTED SUMP STRAINER WILL PREVENT THE PROPER WASHING RINSING AND DRAINING OF THE MACHINE.

! ATTENTION !
WIPE THE EXTERIOR OF THE MACHINE WITH A SOFT CLOTH AND MILD DETERGENT. DO NOT SPRAY THE EXTERIOR WITH WATER OR BLEACH.
LEAVE THE DOOR OPEN TO AID IN OVERNIGHT DRYING.

DELIMING

**WARNING:**

Death or serious injury may result when deliming solution is mixed with sodium hypochlorite (chlorine bleach) sanitizing agent. Mixing may cause hazardous gases to form. Deliming solution and other acids must never be mixed with chlorine, iodine, bromine, or fluorine.

Deliming solutions can cause severe irritation and possible chemical burns. Always wear protective clothing and goggles when handling chemicals.

Follow the steps below to delime the dishwasher.

1. Open the dishwasher door and remove the dish rack.
2. Remove the detergent and rinse-aid chemical supply tubing from their chemical supply containers.
3. Place the pick-up tubes in a container of hot water.
4. Push the dishwasher power switch to the ON position. The dishwasher will fill with water.
5. Press and hold the detergent prime switch UP to flush the detergent from the supply tubing. Release the switch.
6. Turn the dishwasher power switch to OFF/DRAIN to drain the wash tank. The WASH indicator light will go out in about 2 minutes.
7. **Always wear eye protection, rubber gloves and protective clothing when handling chemicals.**
8. Open the door and carefully add the deliming chemical to the wash tank in accordance with your chemical supplier's instructions. Be careful to avoid splashing.
9. Close the door.
10. Press the power switch to the ON position. The machine will fill with water.
11. Press and hold the Start button for one second to initiate an automatic cycle.
12. When the cycle has ended, open the door and check the deliming results. Clean the rinse arm jets with a paper clip to ensure they are clear.
Repeat steps 6-11 if necessary. Push the power switch to OFF/Drain to drain the machine.
13. Push the power switch ON to refill the machine. Place an empty dish rack in the machine.
14. Run 4 empty cycles to ensure all deliming chemicals are flushed from the machine.
15. Return chemical supply tubing to their containers and prime the chemical lines.
16. Deliming is complete.

MAINTENANCE SCHEDULES

Daily Maintenance

1. Check all of the wash arm and rinse arm spray jets and clean as necessary.
2. Check scrap screen, and sump strainer and clean as necessary.
3. Make sure the water supply is on and the drain is not clogged.
4. Check the temperature display and ensure it is operating.
5. Make sure the dish racks are in good condition.
6. Check the chemical containers and refill as required.
7. Follow the cleaning procedures.

Weekly Maintenance

1. Perform Steps 1-6 in the Daily Maintenance.
2. Inspect water lines for leaks.
3. Check for water leaks underneath the dishwasher.
4. Make sure the floor drain and/or drain lines are unobstructed.
5. Make sure the dishwasher is level.
6. Clean accumulated lime deposits from the wash tank heating element.
7. Inspect the scrap screen and replace if damaged.
8. Check the spray arms and replace or repair if damaged.
9. Inspect machine interior for lime build-up (white haze) and delime if necessary. Consult the chemical supplier for deliming chemicals.

Semi-Annual Maintenance

1. Inspect the chemical dispensing pump tubing for cuts, kinks or bends and replace if necessary.
2. Flush chemical tubing with hot water:
Place an empty dish rack inside the dishwasher. Remove the pick-up tubes from the chemical containers. Place the tubes in a container of hot water and run the dishwasher for twenty cycles to thoroughly flush the lines. Check the lines to ensure they are unobstructed.
3. Disassemble the detergent pump and replace the squeeze tube. Reassemble.
4. Return the pick-up tubes into full chemical containers and return the machine to service.
5. Detergent squeeze tubes should be inspected or replaced every six months.

Yearly Maintenance

Contact your authorized service agent for a preventive maintenance inspection.

Lubrication

There are no lubrication points for this dishwasher.

**This Page
Intentionally
Left Blank**

DIAGNOSTIC FEATURES

To access diagnostic features:

1. Turn power switch to "OFF".
2. Push start button 3 times.
3. Machine will now step through and operate the components as shown below.

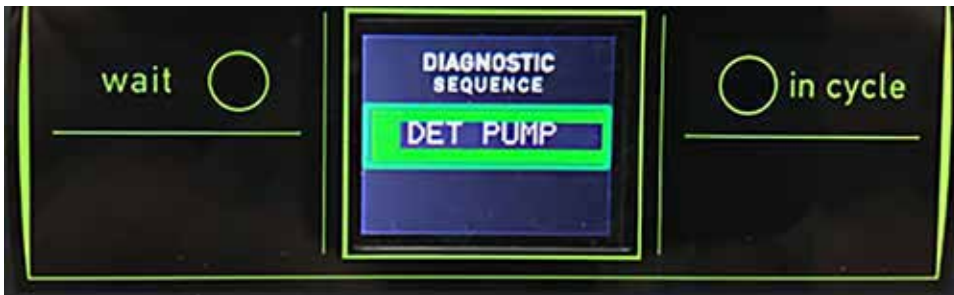

(continued on next page)



Diagnostic Features (continued)

SENSOR FAULT

1. Sensor Fault Icon indicates machine requires servicing (wash, rinse, or booster sensor).
2. Machine will still operate at reduced capacity.
3. Caution Icon will continue to show during cycles.



Notice the "CAUTION" icon

PARAMETER SETTINGS INSTRUCTIONS

0514058 REV A -30-MAR-2021

CAUTION: Parameter changes must be made by qualified personnel only.

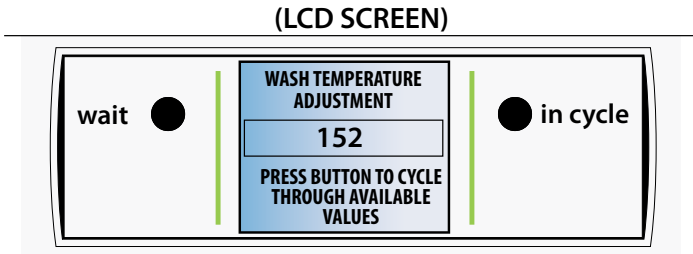

The following parameters may be changed depending on model:

1. DETERGENT CONCENTRATION
2. RINSE TEMP
3. WASH TEMP
4. FILL TIME
5. UNITS (F-C)
6. LANGUAGE (English - French)
7. RINSE AID CONCENTRATION

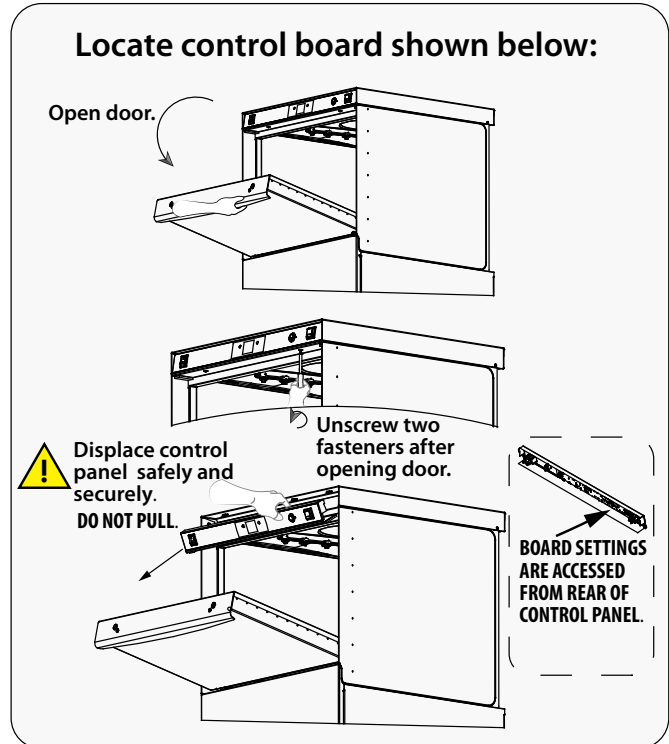

Back of the board

PARAMETER SETTINGS (continued)

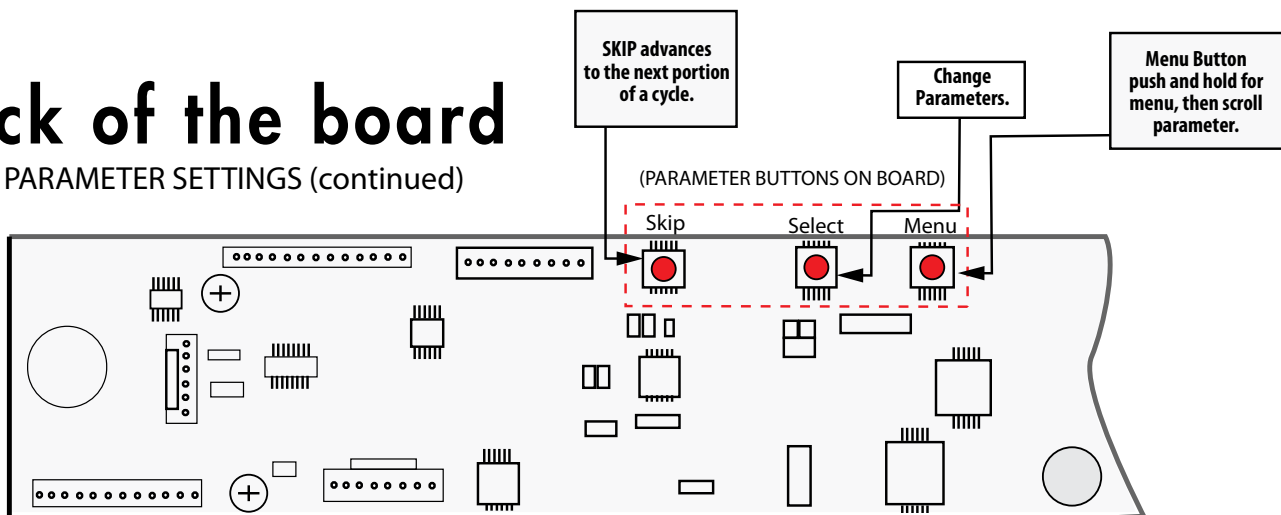

To Change Parameters:

1. Push and Hold the "Menu" button.
2. DET settings screen will appear first.
3. Push menu button to scroll through until desired parameter is reached.
4. Push "CHANGE" button until desired setting is reached.
5. Release and control will return to normal operation (approximately 3 seconds).

**This Page
Intentionally
Left Blank**

Service Replacement Parts

Illustrations	Page
Terminal Block	32
Booster	34
Chemical Pumps.....	36
Control Panel.....	38
Nozzles	40
Wash Arms	42
Panels and Door	44
Rear Plumbing.....	46
Sump	48
Dish Racks	50
Pump and Motor	52

Terminal Block

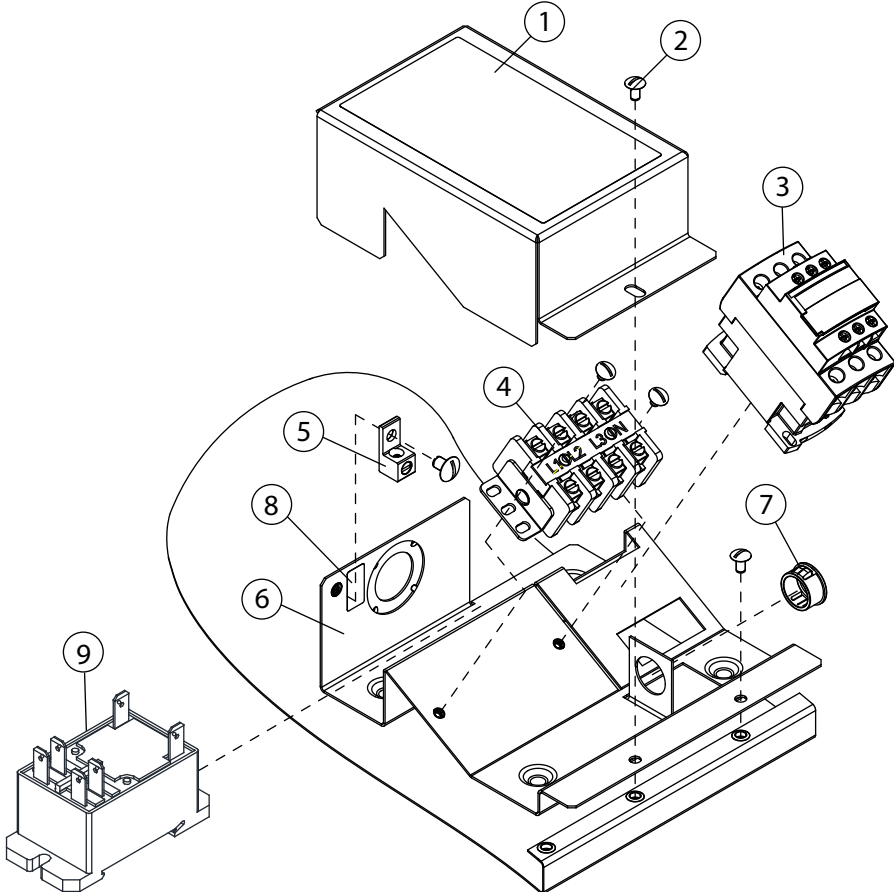

Item No.	Part No.	Description	Qty.
1	0313396	COVER, BOX WIRING	1
2	0501411	SCREW, 10-32 X 1/4", TRUSS HD.	2
3	C120444	CONTACTOR, 3-POLE 220VAC COIL	1
4	0509527	BLOCK, TERMINAL, 4-POLE	1
5	103310	LUG, GROUND	1
6	0313395	BOX, WIRING	1
7	107964	BUSHING, STRAIN RELIEF, SMALL	1
8	0503592	LABEL, GROUND	1
9	0514162	RELAY,DPST 30A 240VAC 240V COIL	1

Booster

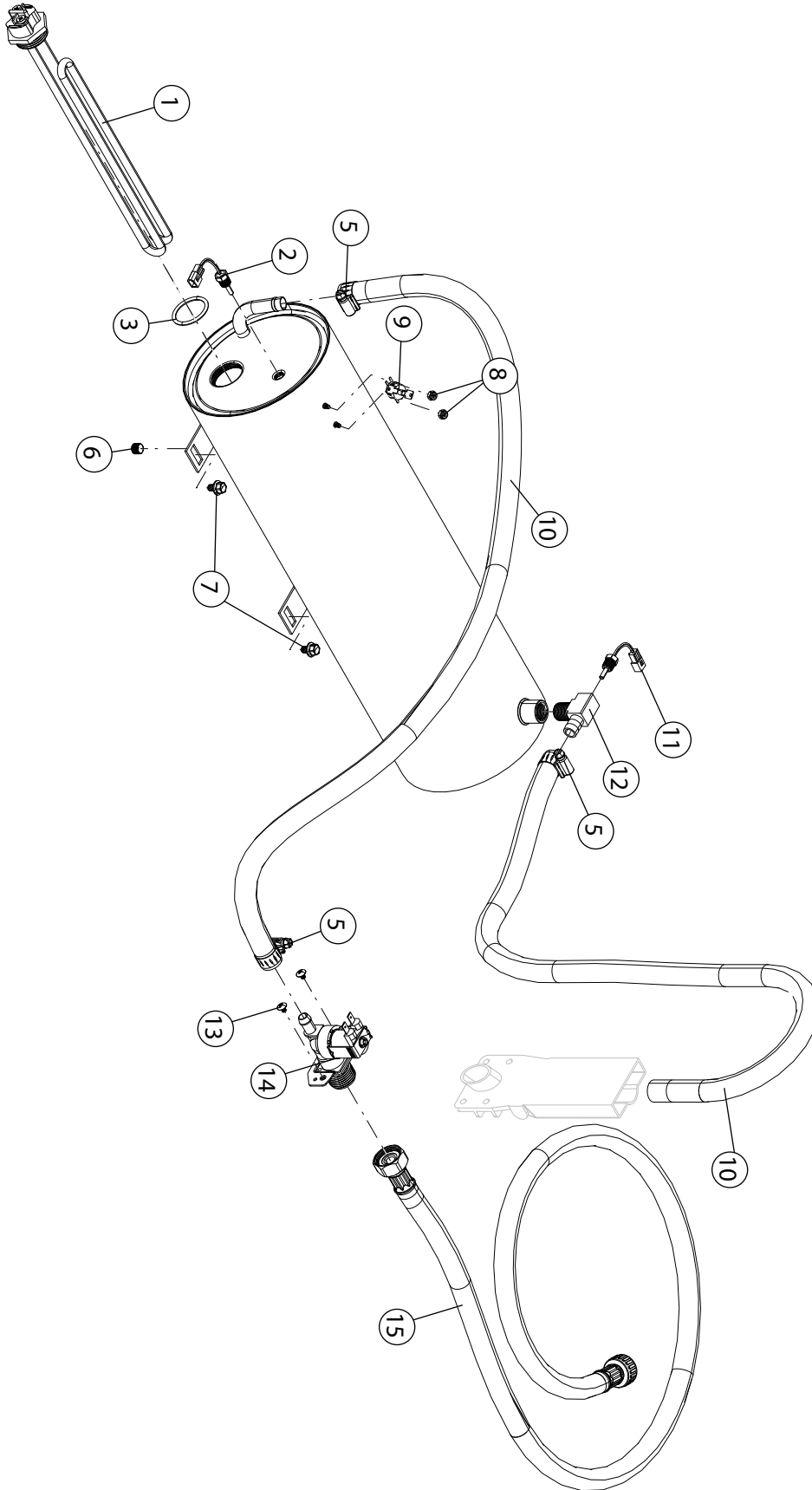

Item No.	Part No.	Description	Qty.
1	0513988	HEATER, 5KW /220V	1
2	0513310	THERMISTOR, PROBE ASSY.	1
3	0512928	GASKET	1
4	0713850	BOOSTER, WELDED ASSY.	1
5	0512985	CLAMP, SS GEAR-MIN. 1/2"	1
6	0508817	PLUG 1/8 HEX COUNTERSUNK SS	1
7	0512185	BOLT, HEX FLANGE, 1/4-20 X 3/8" SST	2
8	108954	NUT, GRIP 6-32 W/NYLON INSERT SST	2
9	110562	THERMOSTAT, HIGH LIMIT 240°F	1
10	107417	HOSE, RUBBER 1/2" ID X .84" OD	A/R
11	0513310	THERMISTOR 10 kΩ, 2-WIRE	2
12	0513314	TEE, RINSE	1
13	0514200	SCREW M4 X 12MM SS EXTRA WIDE PHIL.	2
14	0513972	VALVE WATER INLET 220V NX SERIES	1
15	0514047	HOSE	1

Chemical Pumps

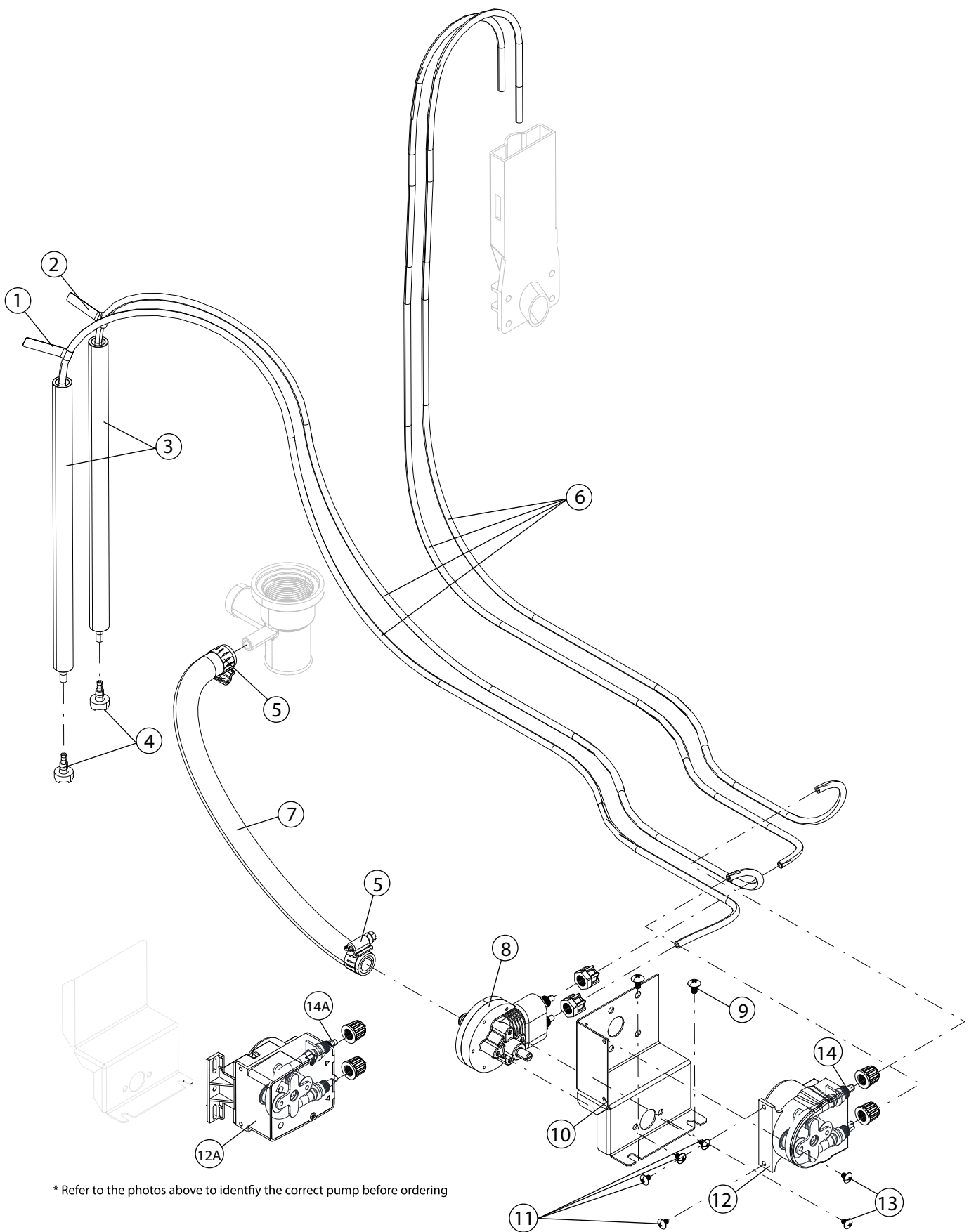

* Refer to the photos above to identify the correct pump before ordering

Item No.	Part No.	Description	Qty.
1	0505483	LABEL, RINSE-AID HOSE	1
2	0503695	LABEL, DETERGENT HOSE	1
3	0306363	TUBE, 3/8" ID X 12" LG. STIFFENER	A/R
4	0501869	STRAINER	2
5	0512985	CLAMP, SS GEAR-MIN. 1/2"	2
6	0512475-1	HOSE 4MM ID 6MM OD PVC	A/R
7	107417	HOSE, RUBBER 1/2" ID X .84" OD	A/R
8	0513986	RINSE AID PUMP	1
9	100007	SCREW 10-32 X 3/8" TRUSS HD	2
10	0313977	BRACKET	1
11	0501563	SCREW #8 3/8" SS PHILLIP TRUSS HD	4
12	0513936	NEXUS DETERGENT PUMP (AFTER S/N W2202105579)	1
12A*	0713937	KIT,NEXUS DETERGENT PUMP REPLACEMENT (PRIOR TO S/N W2202105579)	1
13	0501563	SCREW #8 3/8" SS PHILLIP TRUSS HD2	2
14	0514073	TUBE, PERISTALTIC SQUEEZE (FROM W2202105579)	1
14A*	H35137	SQUEEZE TUBE, DETERGENT PUMP (FROM W190688229 TO W2202105579)	1

* Refer to the photos above to identify the correct pump before ordering

Chemical Pumps

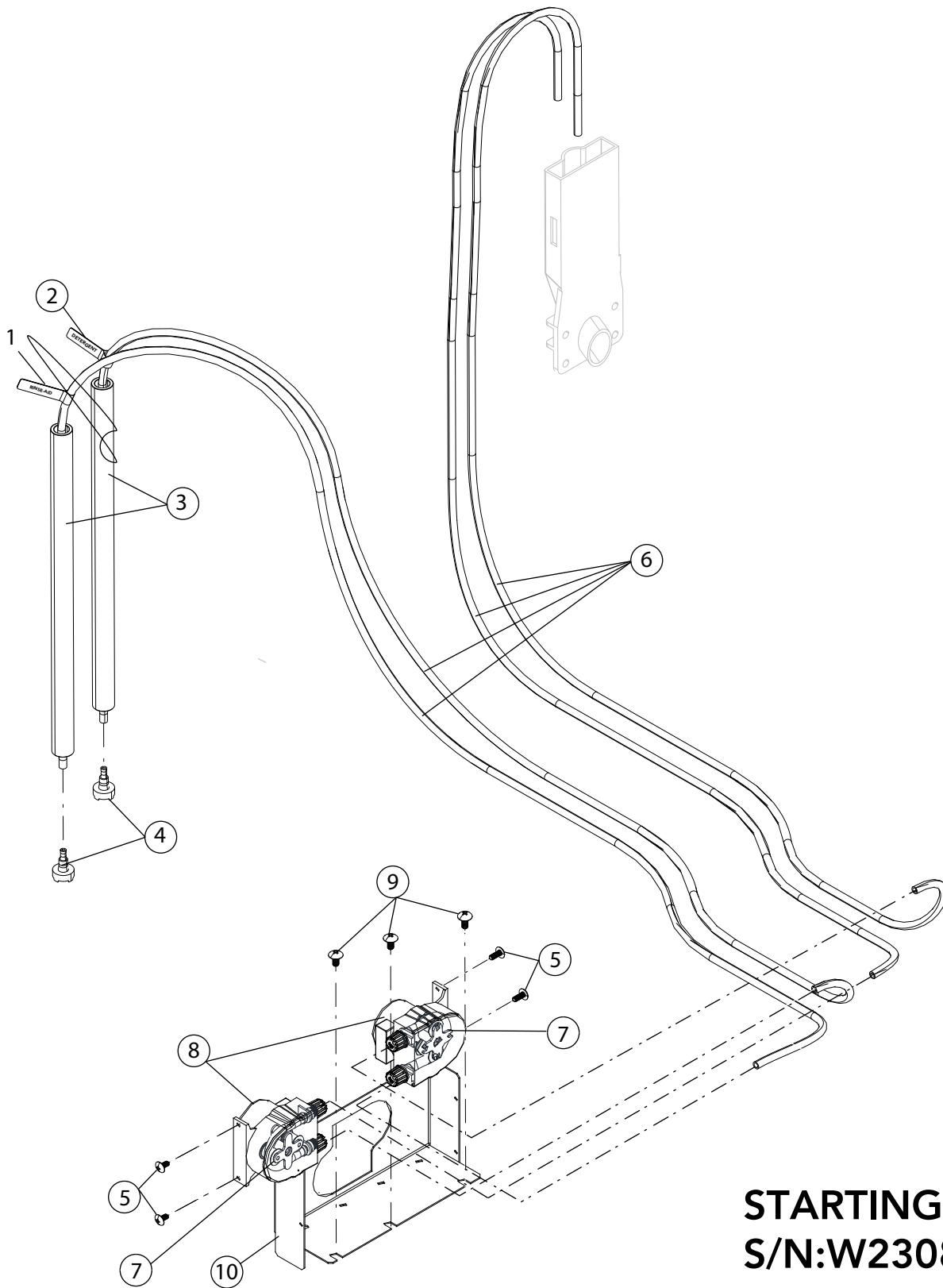

**STARTING AFTER:
S/N:W2308114912**

* Refer to the photos above to identify the correct pump before ordering

Item No.	Part No.	Description	Qty.
1	0505483	LABEL, RINSE-AID HOSE	1
2	0503695	LABEL, DETERGENT HOSE	1
3	0306363	TUBE, 3/8" ID X 12" LG. STIFFENER	A/R
4	0501869	STRAINER	2
5	0501563	SCREW #8 3/8" SS PHILLIP TRUSS HD	4
6	0512475-1	HOSE 4MM ID 6MM OD PVC	A/R
7	0514073	SQUEEZE TUBE (AFTER S/N W2307114545)	A/R
8	0513936	PUMP, DETERGENT PERISTALTIC BLK 220VAC	2
9	100007	SCREW 10-32 X 3/8" TRUSS HD	3
10	0314124	BRACKET, CHEMICAL PUMP NEXUS HT M1.5	1
11	0501563	SCREW #8 3/8" SS PHILLIP TRUSS HD	4
12	0514073	SQUEEZE TUBE (AFTER S/N W2307113905)	2

Control Panel

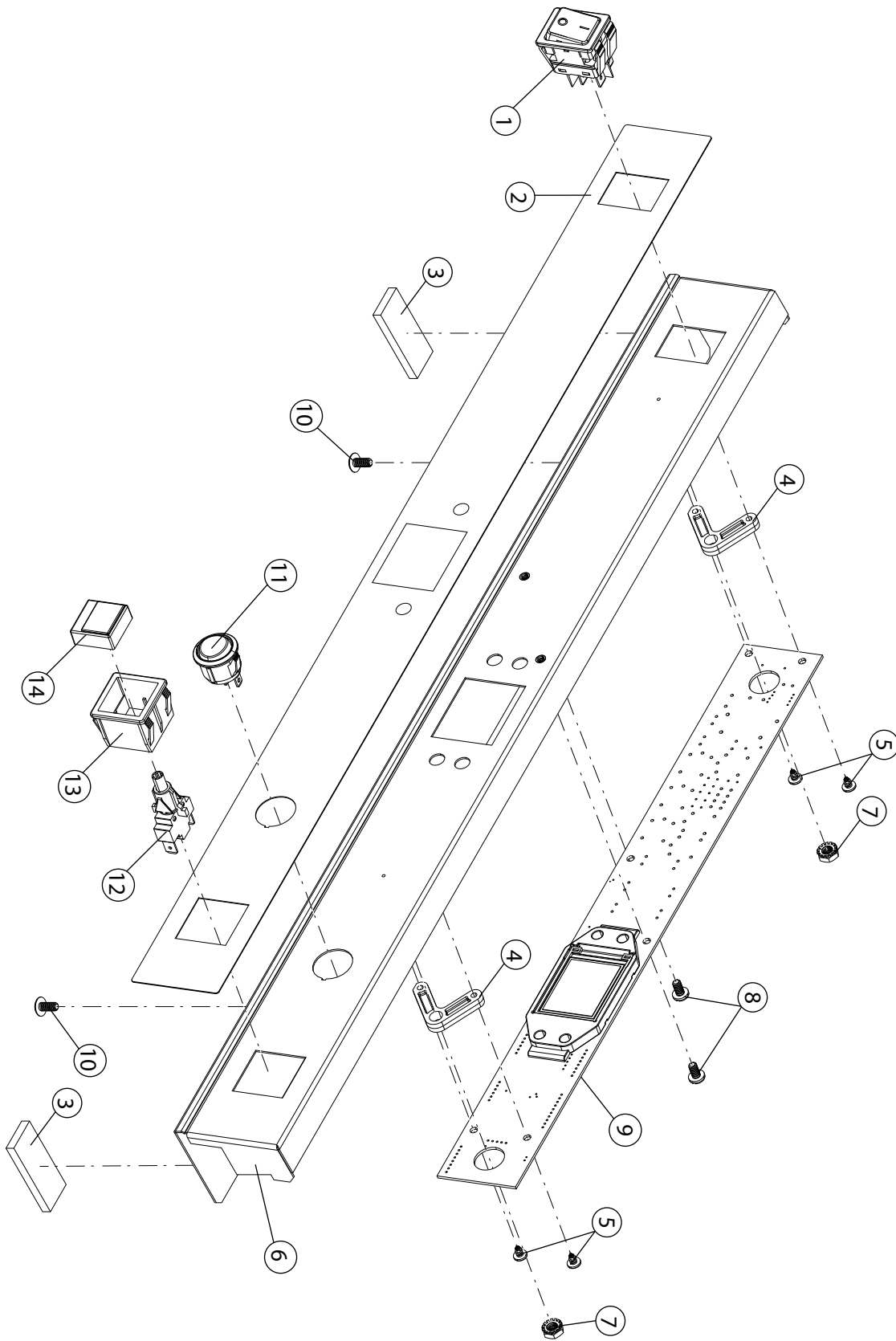

Item No.	Part No.	Description	Qty.
1	0512221	SWITCH, ROCKER DPST 250V NEON	1
2	0513958	LABEL, FACIA NEXUS	2
3	0512320	GASKET, STEAM	2
4	0512357	STANDOFF, LED DISPLAY BOARD	2
5	0512978	SCREW 6-18 X 1/4 PAN HEAD PHILLIPS SS	4
6	0313957	PANEL, FACIA NEXUS, HT	1
7	0503580	NUT, 10-32	2
8	0501563	SCREW, #8 X 3/8"	2
9	0713985	KIT, CONTROL BOARD	1
10	104624	SCREW 8-32 X 3/8 TRUSS HD	1
11	0512226	SWITCH, ROCKER RND SPDT MOMENTARY	1
12	0512216	CONTACT, SWITCH MOMENTARY (N.O.)	1
13	0512217	HOUSING, PUSH BUTTON SWITCH	1
14	0512218	PUSH BUTTON, GREEN	1
---	0513836	HARNESS, SWITCH - NOT SHOWN	1
---	0513974	HARNESS, SENSOR - NOT SHOWN	1
---	0513973	HARNESS, MAIN -NOT SHOWN BEFORE S/NW2308114912)	1
---	0514121	HARNESSNEXUSWIRINGM1.5 ,MAIN NOT SHOWN (AFTER S/N W2308114912)	1

Nozzles

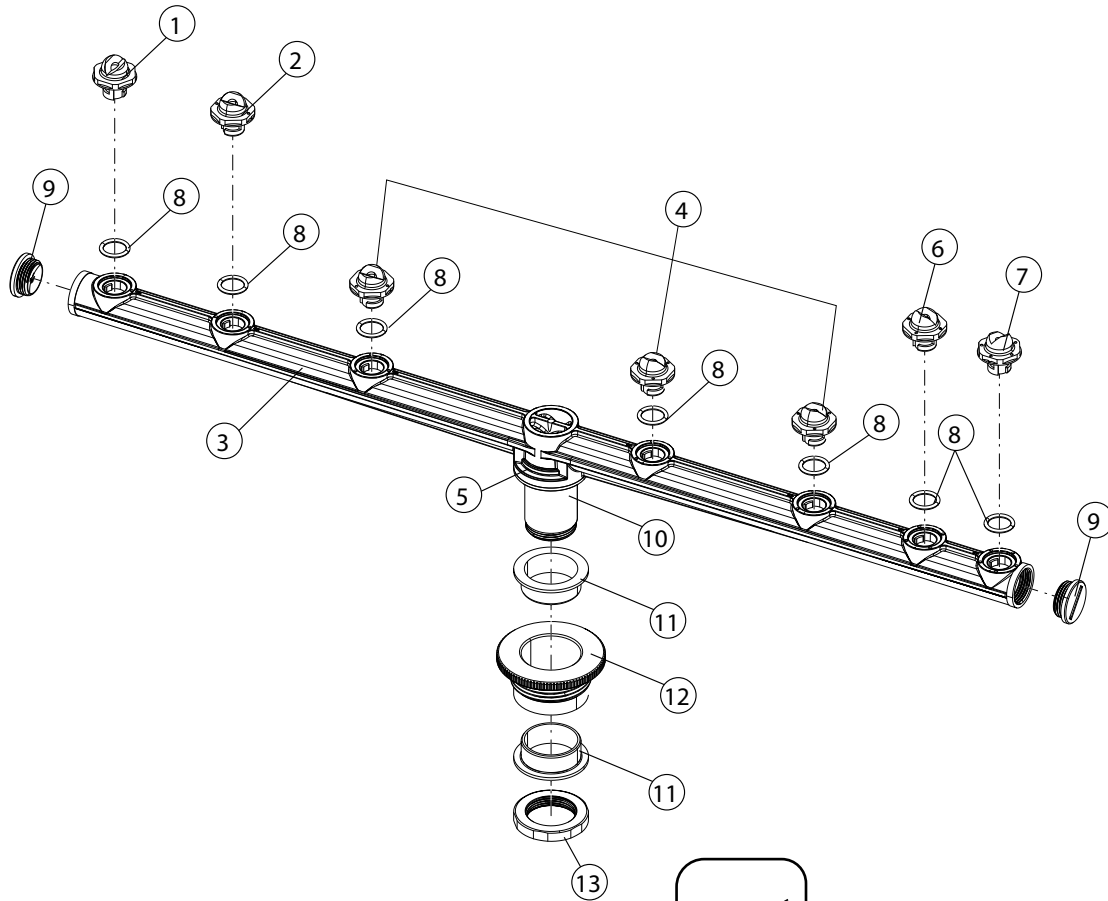

The number of dots on the nozzles correspond to the port in which it is assembled. The ports are keyed for the matching nozzle. Do not force a nozzle into the incorrect port.

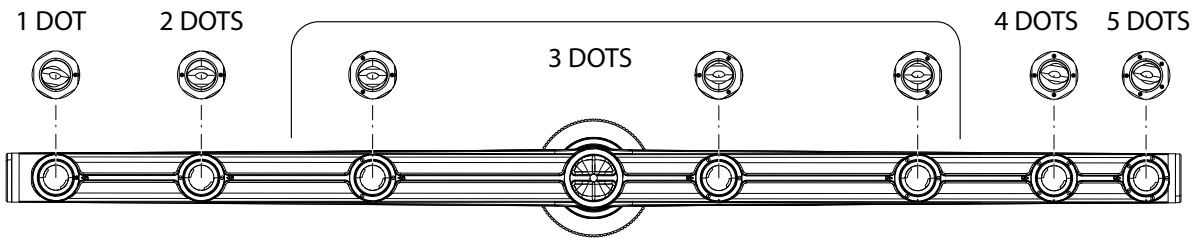
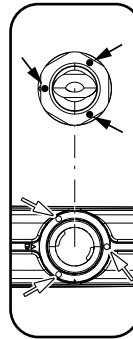

Item No.	Part No.	Description	Qty.
1*	0513992	NOZZLE 1, WASH ARM	1
2*	0513993	NOZZLE 2, WASH ARM	1
3	0513990	WASH ARM	1
4*	0513994	NOZZLE 3, WASH ARM	3
5	0513997	WASHER, BEARING WASH ARM	1
6*	0513995	NOZZLE 4, WASH ARM	1
7*	0513996	NOZZLE 5, WASH ARM	1
8*	0514000	O-RING, NOZZLE WASH ARM	7
9	0513991	ENDCAP, WASH ARM	2
10	0513998	SHAFT, WASH ARM	1
11	0514001	BEARING, WASH ARM	2
12	0514002	BEARING, HOUSING WASH ARM	1
13	0513999	NUT, BEARING WASH ARM	1
---	0714049	KIT, NOZZLE (contains Items 1, 2, 4 and 6-9)	A/R
---	0513971	ASSY., WASH ARM COMPLETE	A/R

* NOTE: ITEMS 1, 2 ,4 AND 6-9 ARE NOT AVAILABLE SEPERATELY.
PLEASE ORDER 0714049

Wash Arms

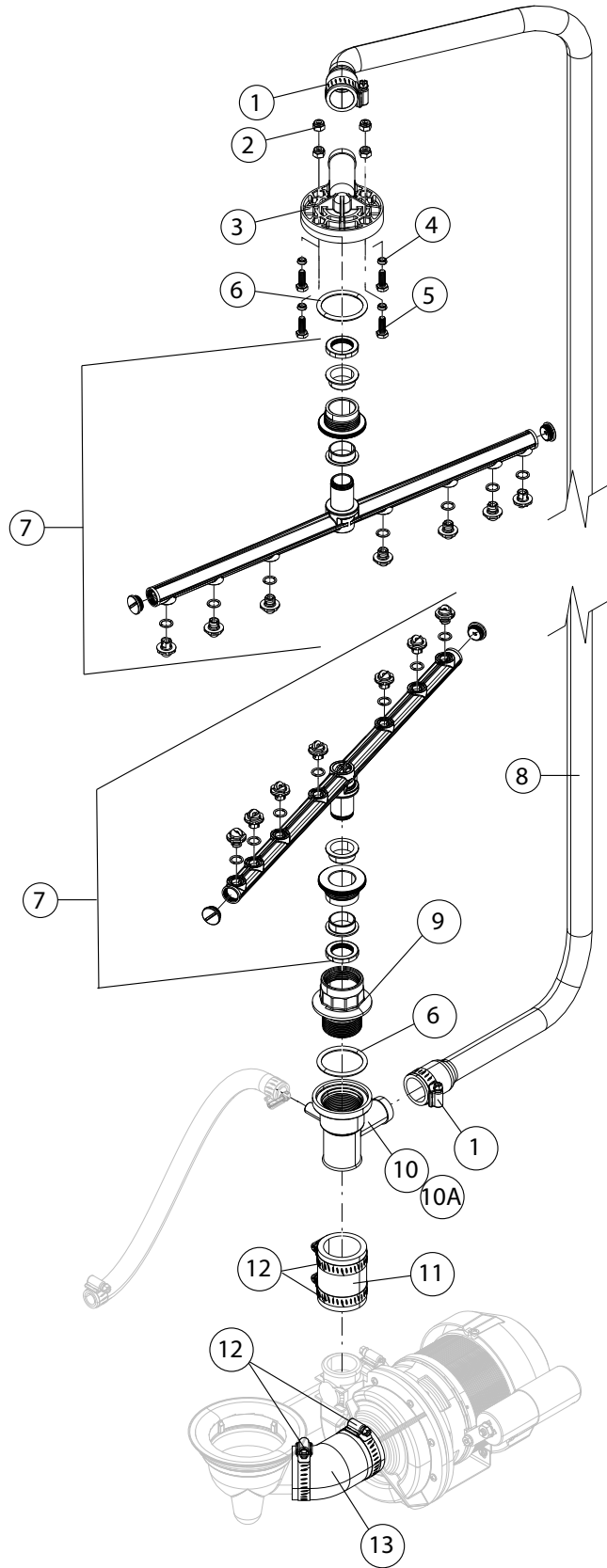

Item No.	Part No.	Description	Qty.
1	0502571	CLAMP, HOSE GEAR HOSE 1-1/2" SST	2
2	107967	NUT, HEX SST 1/4-20 NYLON INSERT	2
3	0513968	HUB UPPER WASH SYSTEM	1
4	0501481	WASHER, NYLTITE	4
5	100736	BOLT 1/4-20 X 3/4" HEX HEADO	4
6	0512133	O-RING, 2-1/8" OD X 1-3/4" ID X 3/16"	1
7	0513971	ASSEMBLY, WASH ARM	2
8	0512120	HOSE, UPPER WASH ARM	1
9	0513967	HUB, LOWER WASH ARM	1
10	0513969-1	MANIFOLD, WASH PUMP NEXUS PLUGGED M1.5 (AFTER S/N W2308114912)	1
10A*	0513969	MANIFOLD, WASH PUMP NX SERIES (BEFORE S/N W2308114912)	1
11	0513983	HOSE, PUMP DISCHARGE	1
12	0512322	CLAMP, HOSE GEAR 1X 13/16" - 2 X 3/4" SS	4
13	0513982	HOSE, PUMP SUCTION	1

Panels and Door

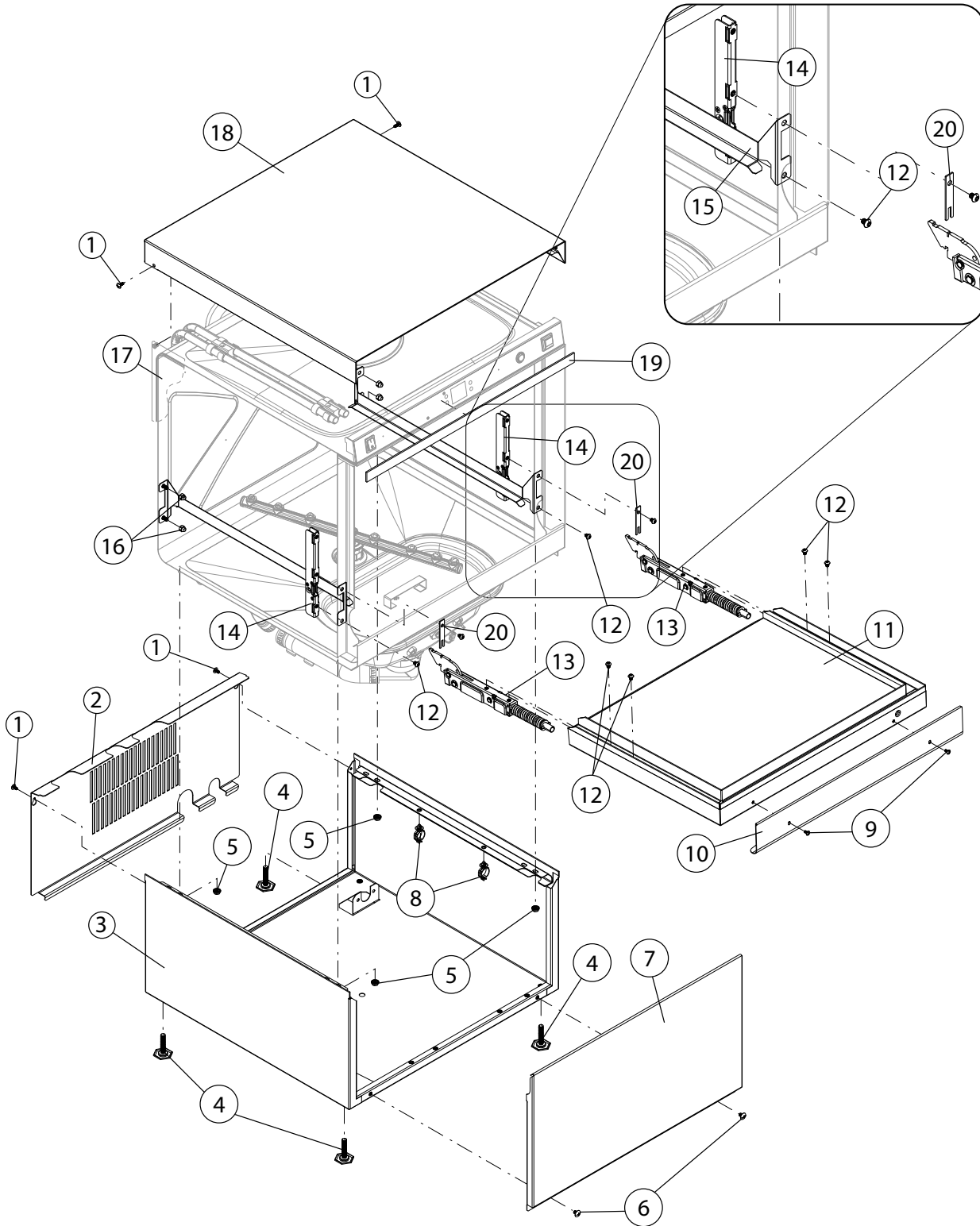

Item No.	Part No.	Description	Qty.
1	100007	SCREW, TRUSS SLOT SST 10-32 X 3/8"	A/R
2	0313955	PANEL, REAR (Prior to S/N 190990970)	1
3a	0313955-1	PANEL, REAR (Beginning w/ S/N W190990970 and above)	1
3	0713944	WELDMENT, BASE	1
4	0503718	FOOT, ADJUSTING	4
5	0514473	NUT 1/4-20 WH SERRATED SS	4
6	100779	SCREW, 1/4-20 X 5/8" TRUSS SS PHIL	2
7	0313956	PANEL, FRONT (Prior to S/N 190990970)	1
7a	0313956-1	PANEL, FRONT (Beginning w/ S/N W190990970 and above)	1
8	0513647	CLIP CORD 5/8" PUSH MOUNT	2
9	104624	SCREW, 8-32 X 3/8" TRUSS HD	2
10	0313965	HANDLE, DOOR	1
11	0713950	WELDMENT, DOOR	1
12	0514011	SCREW, ROUND HEAD HEX SS 1/4-20 X 5/16"	4
13	0713966	HINGE, DOOR	2
14	0514003	BRACKET, DOOR HINGE RECEIVER	2
15	0313959	RAIL, TRAY	2
16	106014	NUT, ACORN 1/4-20	4
17	0713946	WELDMENT, WASH TANK	1
18	0313954	PANEL, TOP	1
19	0514009	GASKET, DOOR 23-5/8" LG. GRAY SILICON	1
20	0314028	PLATE, LOCKING HINGE	2
---	0714050	ASSY, DOOR (contains 9, 10, 11,)	A/R
---	0714051	ASSY, DOOR, C/W HINGES (contains 9, 10, 11, 12, 13)	A/R

Rear Plumbing

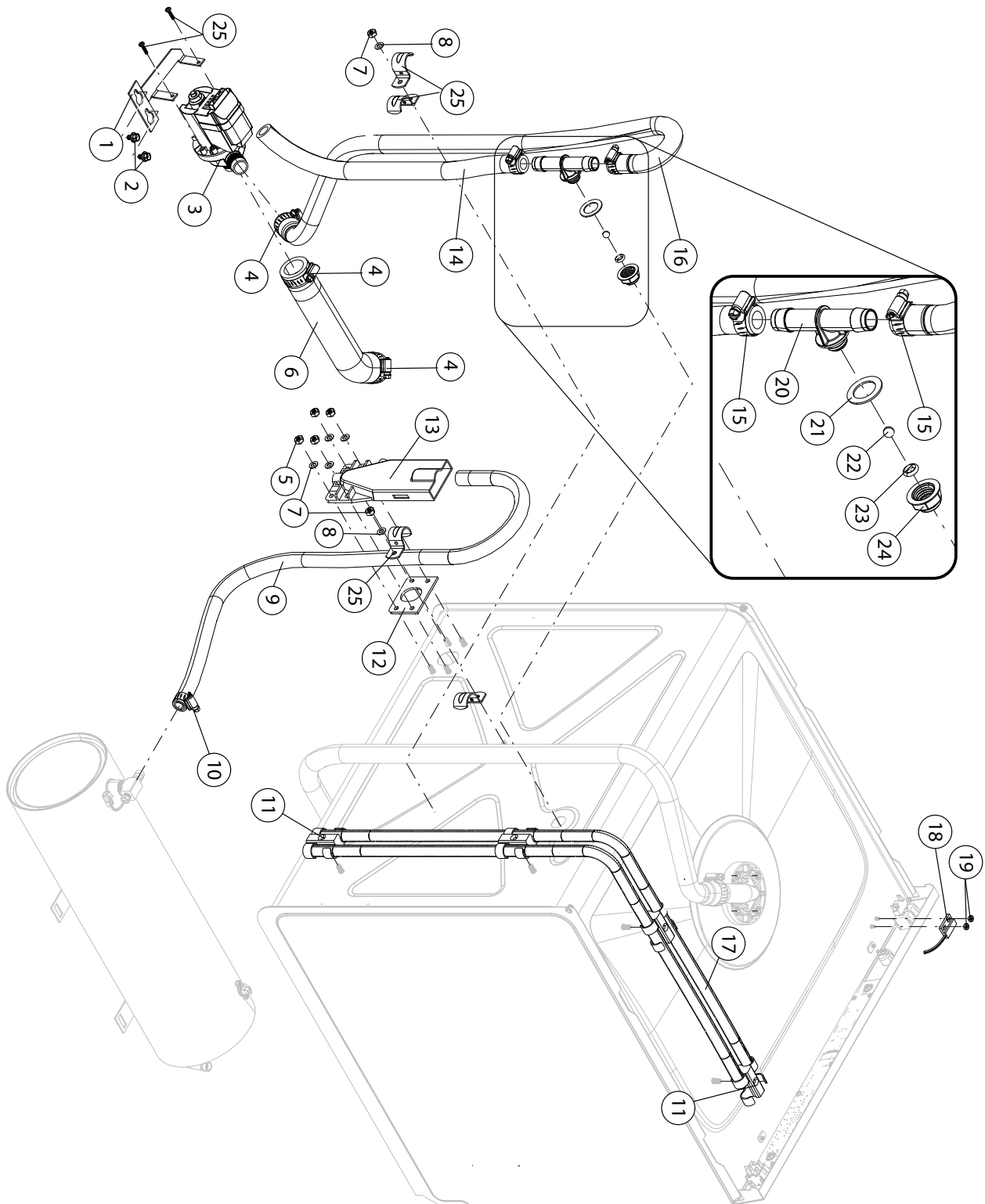

Item No.	Part No.	Description	Qty.
1	0312145-2	BRACKET, DRAIN PUMP	1
2	0512185	BOLT, HEX FLANGE 1/4-20 X 3/8" SST	2
3	0514040	PUMP, DRAIN	1
4	0502571	CLAMP, HOSE GEAR	A/R
5	100003	NUT, PLAIN 1/4-20 SST	5
6	0513984	HOSE, PUMP DRAIN	1
7	107967	NUT, 1/4-20 W/NYLON INSERT SST	5
8	102383	WASHER 17/64 X 1/2 X 0.32 14S	2
9	107417	HOSE, RUBBER 1/2" ID X .84" OD	A/R
10	0512985	CLAMP, SS GEAR-MIN. 1/2"	1
11	0512761	CLAMP, DOUBLE CONDUIT	2
12	0509048	GASKET, INLET CHUTE	1
13	0508867	CHUTE, INLET	1
14	0509302	HOSE, 5/8" ID X 1" OD PVC BRAIDED	A/R
15	0502563	CLAMP, HOSE GEAR SST 3/4-1 1/2" #16	2
16	0513849	HOSE, DRAIN	1
17	0512757	CONDUIT, 1/2"	A/R
18	113721	SWITCH, REED ALEPH	1
19	108954	NUT, GRIP 6-32 WITH NYLON INSERT SST	2
20	0513841	VALVE, ANTISIPHON BODY	1
21	0513848	WASHER, SILICON 7/8" ID X 1-5/16" OD X 1/16"	1
22	0513843	BALL 3/8" DIAMETER SS	1
23	0513847	ORING 5/16" ID X 9/16" OD X 1/8"	1
24	0513842	NUT, ANTISIPHON VALVE	1
25	0308822	CLAMP, EMT 1/2"	3
26	109835	SCREW, #8 X 1/2" SELF-TAPPING	2
---	0714052	ASSY., ANTI-SIPHON VALVE	A/R

Sump

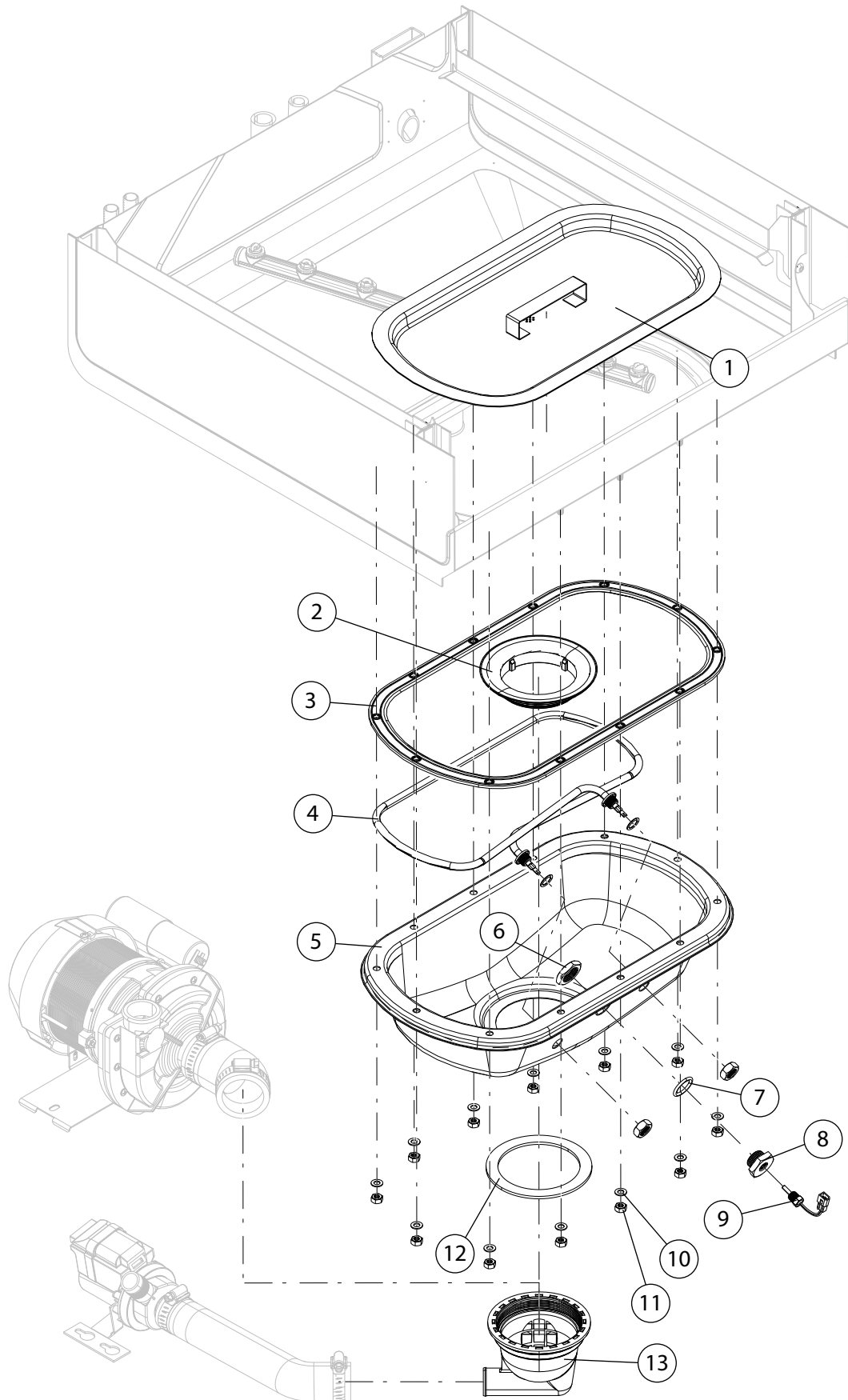

Item No.	Part No.	Description	Qty.
1	0513964	SCRAP SCREEN	1
2	0513981	PUMP SUCTION RING	1
3	0513962	GASKET, UPPER SUMP	1
4	0513970	HEATER, WASH TANK	1
5	0513961	SUMP BOWL	1
6	201029-1	LOCKNUT 1/2" NPT NP	1
7	0501836	O-RING	1
8	0512299	ADAPTOR, THERMISTOR	1
9	0513310	THERMISTOR, 10 K Ω , 2 WIRE ASSY	1
10	102383	WASHER 17/64" X 1/2" X 0.32 14S	12
11	107967	NUT, 1/4-20 W/NYLON INSERT SST	12
12	0513963	GASKET, LOWER SUMP	1
13	0513980	PUMP SUCTION ELBOW	1

Dish Racks

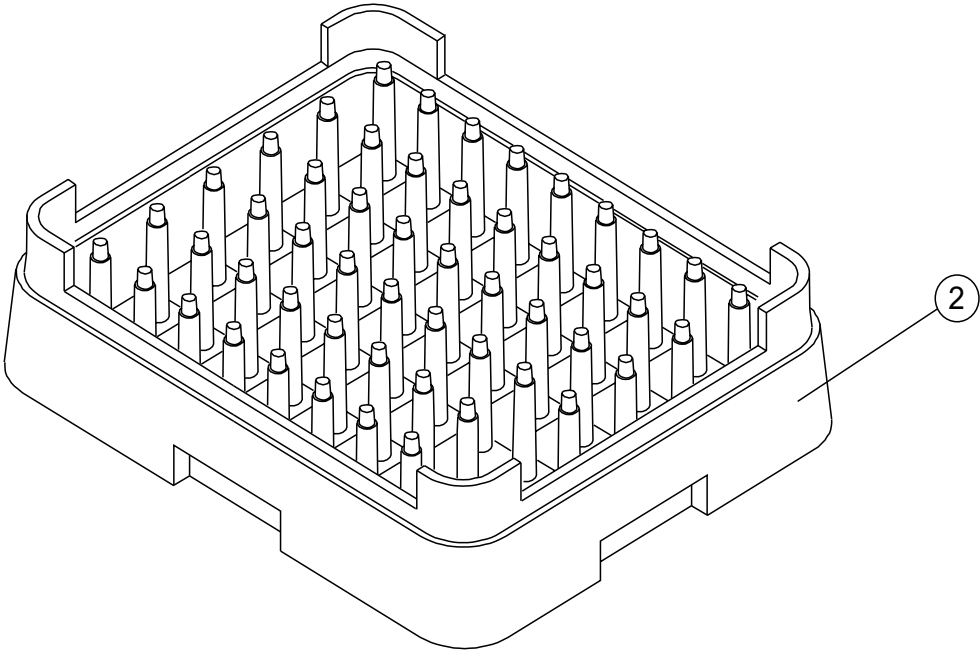
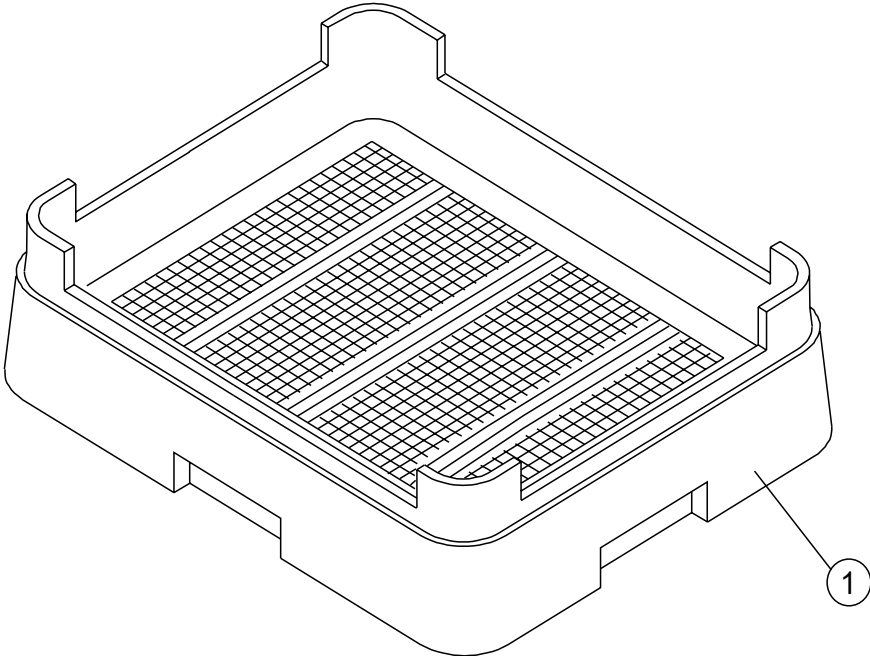

Item No.	Part No.	Description	Qty.
1	101273	OPTIONAL DISH RACK, FLAT-BOTTOM	AR
2	101285	DISH RACK, PEG	AR

Pump and Motor

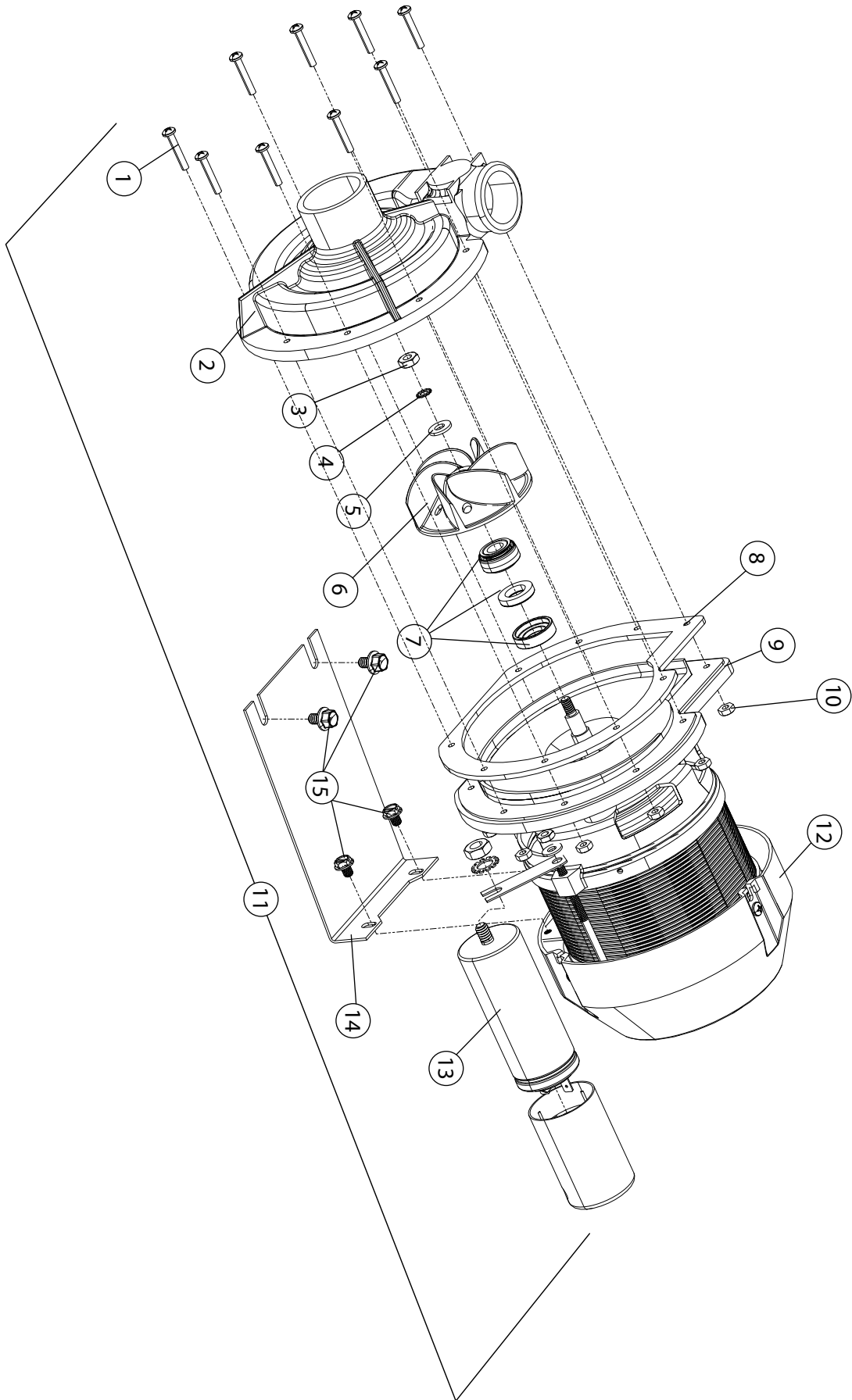

Item No.	Part No.	Description	Qty.
1	0512340	SCREW, M4, PHIL, PAN HD.	9
2	0512341	IMPELLER HOUSING COVER	1
3	114144	NUT, M6 (LEFT-HAND THREAD)	1
4	0501501	WASHER, LOCK, 1/4"	1
5	0501478	WASHER, PLAIN, 17/64"	1
6	0513935	IMPELLER	1
7	114139	SEAL, PUMP	1
8	110285	GASKET, PUMP	1
9	114137	PLATE, PUMP BACKING	1
10	107337	NUT, M4	9
11	0512101-2	PUMP/MOTOR ASSEMBLY COMPLETE 220VAC/50-60/1	1
12	0513131	COVER, REAR MOTOR FAN	1
13	H29043	CAPACITOR 16 μ F	1
14	0313394	BRACKET, WASH PUMP M4	1
15	0512185	BOLT, HEX FLANGE 1/4-20 X 3/8" SST	2

**MOTOR UNAVAILABLE AS SEPARATE PART.
ORDER ITEM 11, PUMP/MOTOR ASSEMBLY P/N 0512101-2.**

Electrical Schematic

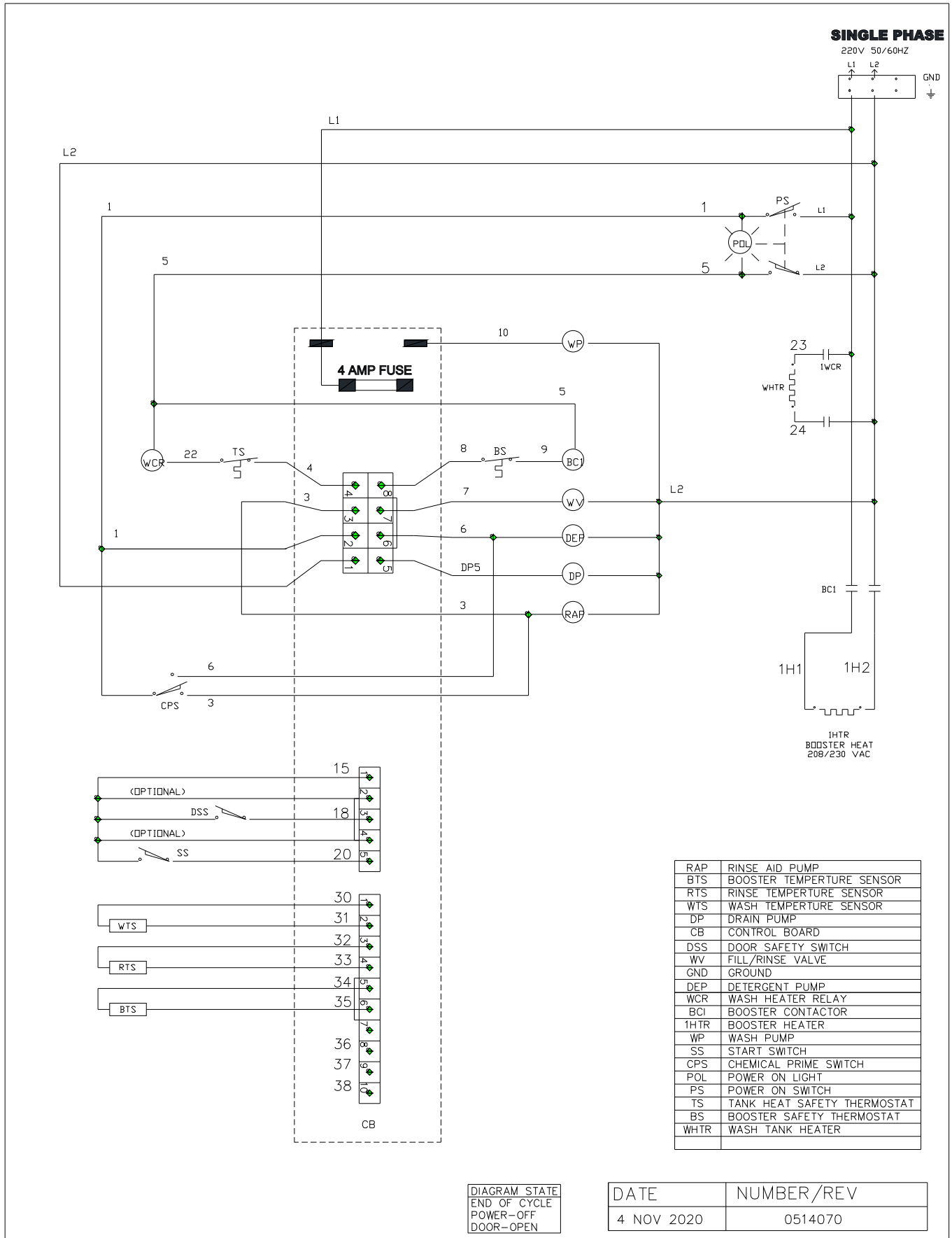

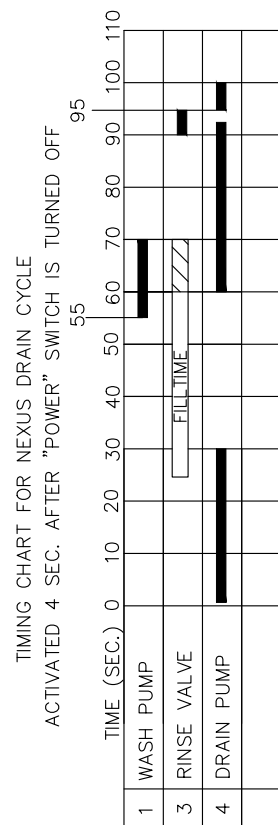
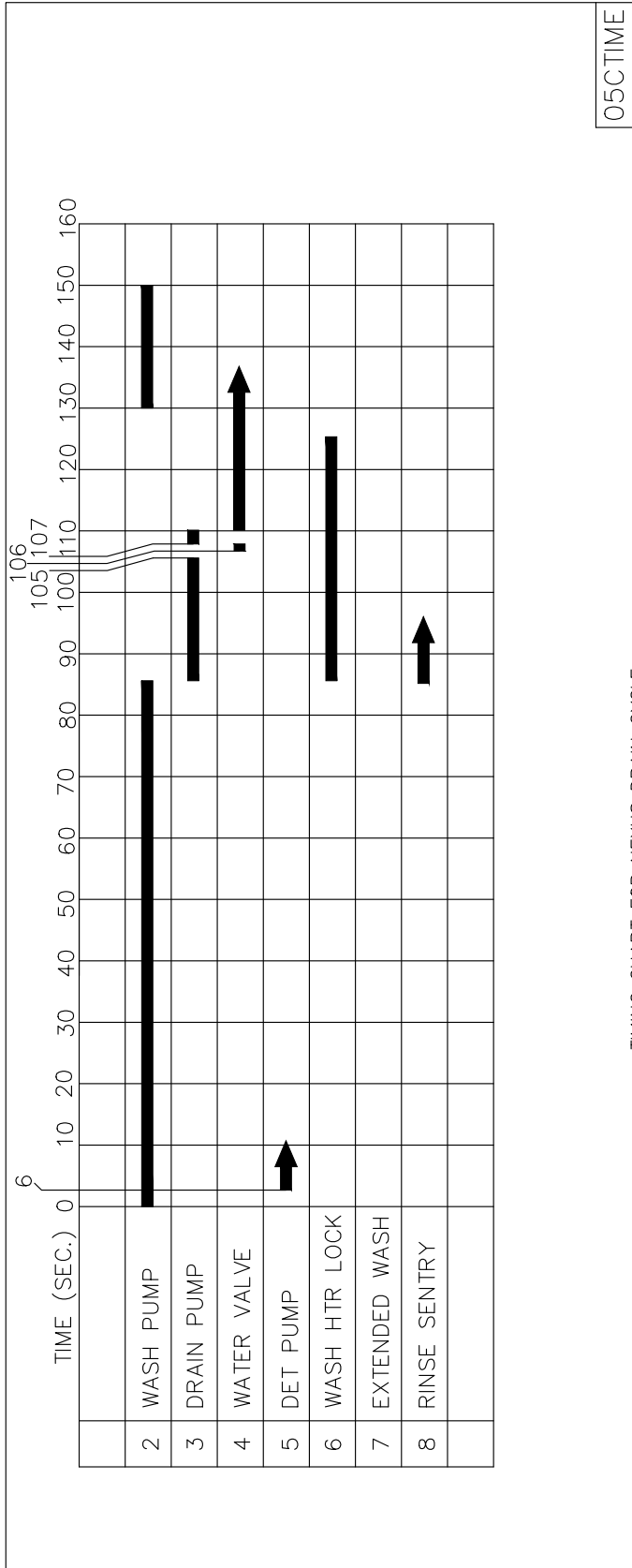

RELEASED TO PRODUCTION	6	DATE
REV ECN	DESCRIPTION	BY CH DATE
A		

MOYER DIEBEL LIMITED
TIMING CHART
NEXUS

TOLERANCE	HOLE DIMENSIONS					ISSUED
DECIMAL	A	F				
ANGLE	B	G				
SCALE 1: 2	C	H				
FORMING DIMENSIONS ARE FROM UNLESS OTHERWISE NOTED	D	I				
	E	J				

DRAWING NO. 05CTIME