

ATTENTION PLUMBERS

FAILURE TO FOLLOW THESE INSTRUCTIONS WILL VOID WARRANTY!

**HR
MODELS**

0513706 REV A - 8-SEPT-2014



Plumbing connections must be made **BEFORE** electrical installation begins. **Damage to the water heaters** will occur if power is turned on without adequate water supply.

All plumbing connections must be made by qualified installers familiar with food service equipment in accordance with all local plumbing codes.

All plumbing connections **must be positioned** to allow the unit to be removable for service and cleaning.

1

- Place dishwasher in permanent location.
- Level Dishwasher with 4 levelling feet.
- Level side to side, and front to back.
Remove front panel.

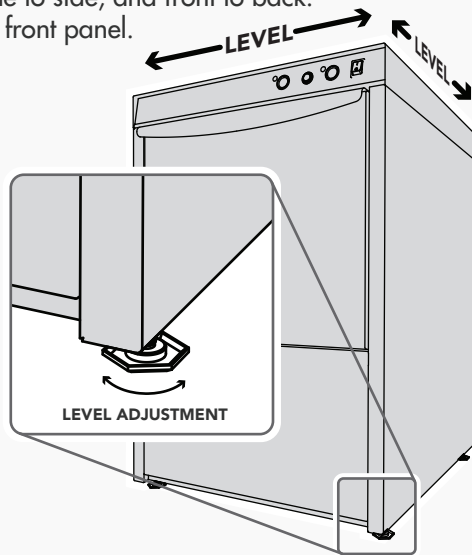

2

- Ensure water temperature and pressure meet the following requirements for optimal performance of the unit.

	INCOMING TEMPERATURE	INCOMING PRESSURE
MIN	55°F / 13°C	20PSI / 138kPa
MAX	80°F / 27°C	90PSI / 620kPa

! MINIMUM 1/2 IN. WATER SUPPLY LINE

- 6 ft. fill hose with 3/4 in. garden hose fitting supplied



- Installation plumber has responsibility to thoroughly flush incoming water line before connecting unit.

Note: A shutoff valve should be installed on incoming water line.

3

- 4 ft. clear braided drain hose supplied

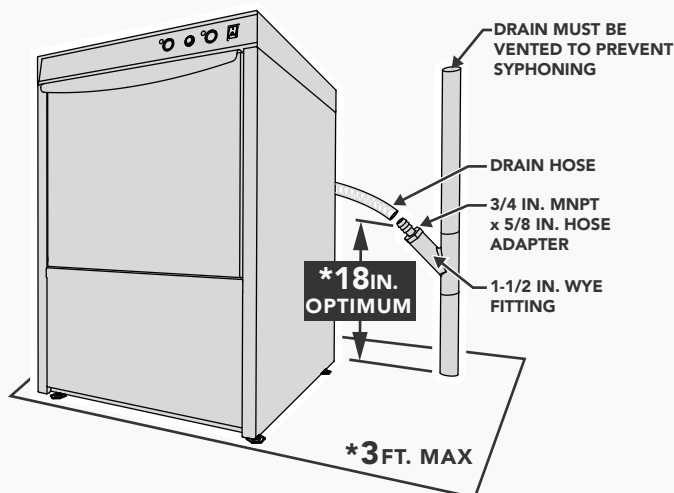

- Drain connection with dedicated waste strongly recommended

! WARRANTY VOID IF:

- extension added to drain hose
- syphon loop modified or removed
- supplied drain fitting not used

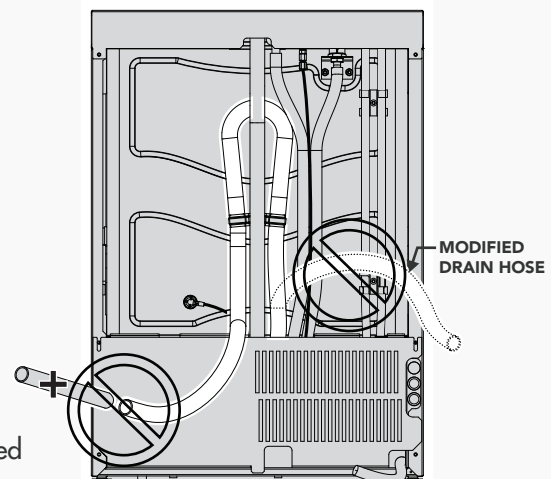

4

- Plumbing installation is now complete.
- Electrician may now proceed with the supplied Undercounter Installation's Electrical sheet.

