

Champion®

The Dishwashing Machine Specialists

Project _____
Item No. _____
Quantity _____

PRO SERIES RACK CONVEYOR

STANDARD FEATURES

- Perpetual rack advance system, with intuitive jam alert, and drive protection
- Proportional rinse, delivering unmatched total ware coverage, utilizing digital pattern cloning, stainless steel nozzles
- 209 racks per hour
- 100 GPH with energy sentinel (idle pump shut-off)
- Prodigy series HMI display, intuitive condition alerts, with user friendly cleaning and operation visual guidance, multi-lingual, touch control
- Proactive maintenance interface, self-diagnostics, problem recognition, with repair recommendation, from HMI touch screen
- Automatic tank fill
- Programmable machine dwell with automatic rack alignment into the optimal wash zone
- **Automatic drain valve *Exclusive!***
- Single-piece hood design
- Single-piece stainless steel upper and lower wash arm manifolds
- Single point electrical connection, machine and built-in booster heater
- 20" standard vertical clearance which accommodates 18" x 26" sheet pans
- Full 180° opening leak proof insulated hinged access doors
- Stainless steel heavy gauge construction including base, legs and feet
- Enclosure panels (front and sides)
- 2 HP pump motor, with stainless steel impeller
- Factory Authorized Start-up
- Vent fan control
- **ENERGY STAR® Qualified**
- **Made in America**



PRO SERIES

44 PRO-S Steam

High Temperature Rack Conveyor
Dishwashing Machine



Model 44 PRO shown with vent cowl and damper option



Photo is for general visual representation only. Please refer to specifications for the latest detailed product information.

SPECIFIER STATEMENT

Specified unit will be Champion Model 44 PRO-S steam high temperature rack conveyor dishwashing machine. Features top mounted Prodigy HMI user interface controls with proactive maintenance software, proportional rinse, using only 100 GPH, built-in booster, at a max of 15 amps for machine and booster, progressive anti-jam drive system, energy sentinel (idle pump shut-off), 209 racks per hour, single-piece hood design, single-piece stainless steel upper & lower wash arms manifolds, full 180° opening leak proof insulated hinged access doors.

1 year parts and labor warranty.

Champion Industries, Inc.
3765 Champion Blvd., Winston-Salem, NC 27105
Tel: 336/661-1556 Fax: 336/661-1979
www.championindustries.com

PRO SERIES

44 PRO Steam

High Temperature Rack Conveyor
Dishwashing Machine

Champion®

The Dishwashing Machine Specialists

MODEL 44 PRO Shipping weight crated: **600 lbs.**

Dimensions shown in inches [mm]

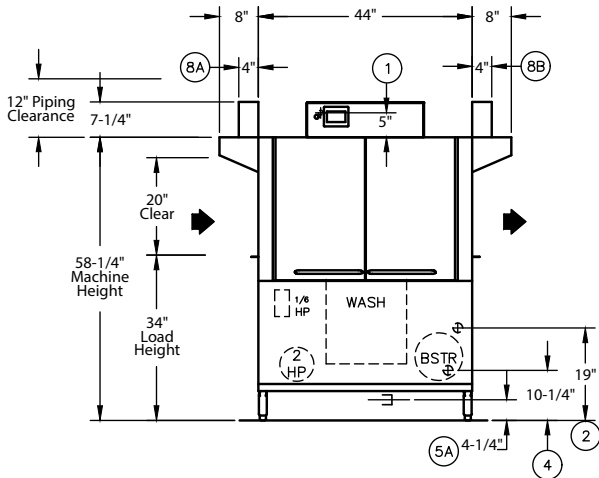

**Front View
Left to Right**

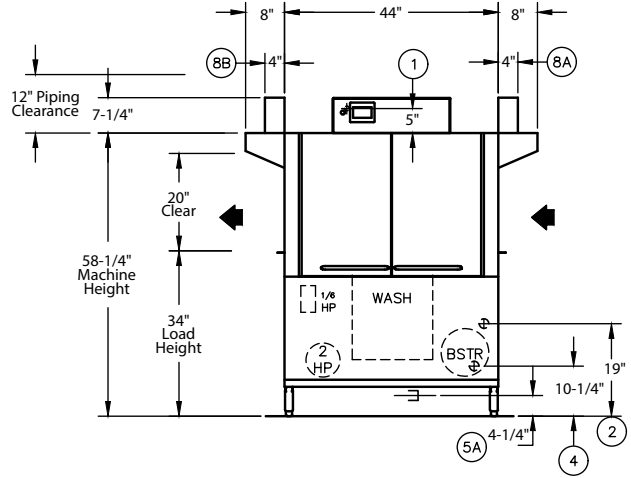

**Front View
Right to Left**

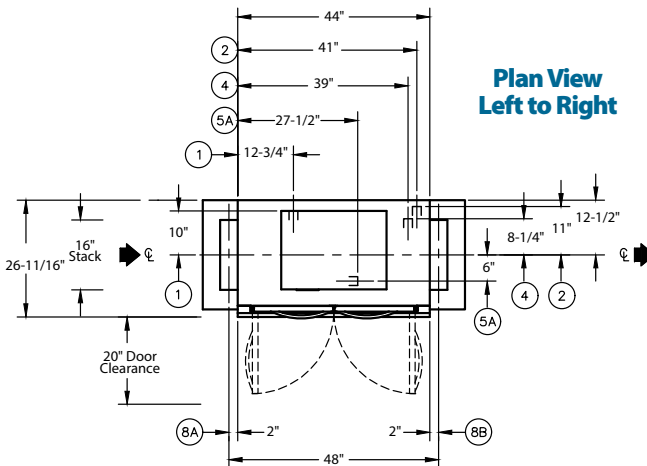

**Plan View
Left to Right**

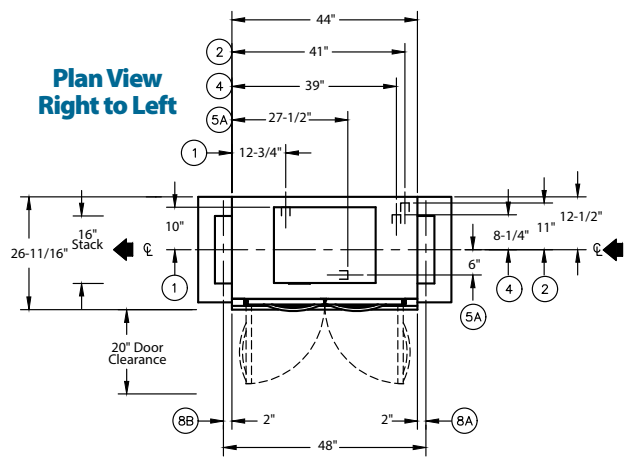

**Plan View
Right to Left**

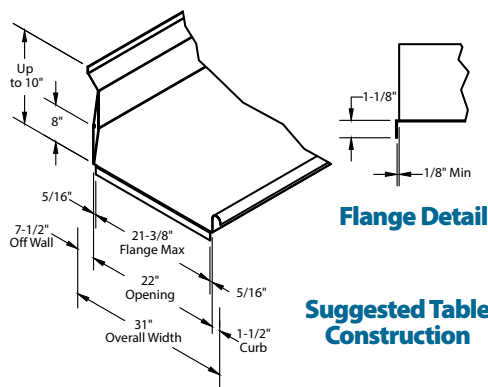

Flange Detail

**Suggested Table
Construction**

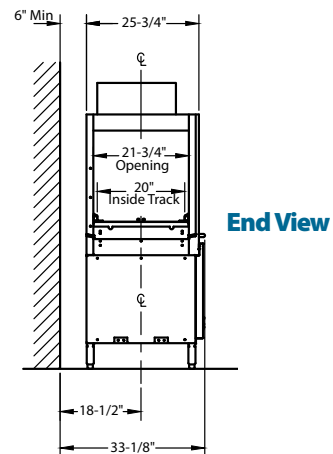

End View

Due to an ongoing value analysis program at Champion, specifications contained in this catalog are subject to change without notice.

Champion Industries, Inc., 3765 Champion Blvd., Winston-Salem, NC 27105 • 336/661-1556 • Fax: 336/661-1979 • www.championindustries.com

PRO SERIES

44 PRO Steam

High Temperature Rack Conveyor
Dishwashing Machine

Champion®

The Dishwashing Machine Specialists

Utilities	
1	Electrical Connection A Machine electrical connection and booster electrical connection
2	Hot Water Machine with built-in booster Main connection 1/2" NPT
3	Cold Water A Machine with drain tempering kit (unmounted. See note 3A (Optional))
4	Hot Water Machine with no booster Main water connection 1/2" NPT
5	Drain Connection 1-1/4" NPT
6	Steam 1-1/4" NPT Machine & Booster (10-30 PSI) flow pressure
7	Condensate 1" NPT Machine return to boiler. No back pressure.
8	Vents A Stack connection - Load end 200 CFM @ 1/4" static pressure B Stack connection - Unload end 400 CFM @ 1/4" static pressure

Warning: Plumbing and electrical connections should be made by qualified personnel who will observe all the applicable plumbing, sanitary, safety codes and the National Electrical Code.

Note: Water Hammer Arrestor (meeting ASSE-1010 standard or equivalent) to be supplied (by others) in common water supply line at service connection.

44 PRO Steam Tank Heat with 40°/70° Rise Booster			
Electrical Specifications	Rated Amps	Minimum Supply Circuit Ampacity	Maximum Overcurrent Protective Device
208/60/1	17	25	25
208/60/3	10	15	15
240/60/1	16	20	20
240/60/3	11	15	15
480/60/3	5	15	15
575/60/3	4	15	15

SPECIFICATIONS

Capacity

Racks per hr. (NSF rated)	209
Wash tank (US gal.)	17
Conveyor speed (ft/min.)	5.8

Motor Horsepower

Drive	1/6
Wash	2

Water Consumption

US Gal. per hr. (max. use)	100
US Gal. per rack	48

Heating

Tank heat, steam (lbs./hr. required at 10 PSI flow pressure)	75
Steam booster (lbs./hr. required for 40°/70° F rise	21

Booster heaters completely inter plumbed, controls are interwired

Venting

Load end (minimum CFM)	200
Unload end (minimum CFM).	400

Standard 20" x 20" rack complement

Peg	2
Flat	1

Plumbing Notes: Because of the variation in house-supplied steam and water pressures, steam and water pressure regulating valves (PRVs) may be needed. (Water PRV is standard on machines with booster.) The PRVs can either be purchased from Champion or obtained locally.

Venting Notes: Fabricated duct size:
3-7/8" x 15-7/8" (Outside dimensions)

PRO SERIES

PRO SERIES RACK CONVEYOR

44 PRO Steam

High Temperature Rack Conveyor
Dishwashing Machine

OPTIONS & ACCESSORIES

- Tank heat: choice of steam coil, electric, hot water coil
- Two-Point electrical connection, separate for machine and booster
- 2 Hp prewash motor (*see 66 PRO spec sheet*)
- 48" Blower-dryer – steam or electric
- Booster Heaters (completely interplumbed, controls are interwired)
 - Steam: 40°F or 70°F rise (*see spec sheet*)
 - Electric: 40-70°F rise (built-in only)
- Heat Recovery
- Cantilever sideloader (with or without hood) for 90° load operation
- 24" Sideload
- 30" Sideload (accepts sheet pans)
- Extended pawl bar (extended drive unit) for use with load tabling
- Racks: peg or flat racks (specify type)
- Table limit switch, unmounted (recommended on all rack conveyor installations) (unmounted)
- Vent cowl, stainless steel with 7" stack and locking damper
- Water pressure regulating valve (unmounted) (standard with booster)
- Two-point electrical connection
- Water hammer kit (unmounted)
- Drain tempering kit (unmounted)
- Model CCT 180 (180° Corner Conveyor Table)
- Model CCT 90 (90° Corner Conveyor Table)
- Model RCT 64 or RCT 84 Roller Conveyor Table (See factory for custom length)
- Splash shields
- NEW** Champion Ventless Heat Recovery (*see spec sheet*)
- ION scale prevention device (unmounted)

Champion[®]

The Dishwashing Machine Specialists



NEW CCT 90

90° Corner Conveyor Table (shown)

NEW CCT 180

180° Corner Conveyor Table
also available



Cantilever Sideloader

(No hood)



Model RCT 64 or RCT 84

Roller
Conveyor Table

Champion Industries, Inc.,
3765 Champion Blvd., NC 27105
336/661-1556 • Fax: 336/661-1979
ChampionIndustries.com

10/19

an Ali Group Company



The Spirit of Excellence