

Champion®

The Dishwashing Machine Specialists

Project _____
Item No. _____
Quantity _____

STANDARD FEATURES

- **ENERGY STAR® Qualified**
- **Exclusive DualRinse Technology**
- One-piece cast stainless steel upper & lower spray arm assemblies
- Internal removable scrap basket and two-piece scrap screen
- Standard vertical opening accommodates 18" x 26" sheet pans
- Wide 26" leakproof swing out insulated hinged doors
- Anti-jam conveyor drive system
- Energy Sentinel (Idle pump shut-off)
- Convenient top-mounted controls
- Automatic tank fill
- Common utility connections
- Door safety switch
- Never leak, ball valve drain closure
- Door activated drain closure
- Enclosure panels (front and sides)
- Low-water tank heat protection
- Rinse-saver device
- Stainless steel heavy-gauge construction, including base and feet
- Wash pump 2 Hp motor
- Stainless steel pump and impeller
- Water pressure regulating valve
- Self-diagnostic controls
- Vent fan control

Single Source
Gas Heating Systems
Hot Water Coil



54 DR 54"

Gas Heated Hot Water Coil
High Temperature Rack Conveyor
Single-tank Dishwashing Machine



DualRinse™

Photo is for general visual representation only. Please refer to specifications for the latest detailed product information.



SPECIFIER STATEMENT

Specified unit will be Champion Model 54 high temperature rack conveyor dishwashing machine. Constructed of Type 304 stainless steel and measuring 54" long with 20-3/4" vertical opening. Features top mounted control cabinet; upper and lower one-piece stainless steel spray arm assemblies, removable internal scrap basket with two-piece scrap screen. Large insulated swing out front access doors. Anti-jam conveyor drive system.

1 year parts and labor warranty.

Champion Industries, Inc.
3765 Champion Blvd., Winston-Salem, NC 27105
Tel: 336/661-1556 Fax: 336/661-1979
www.championindustries.com





54DR GAS RACK CONVEYOR

Gas Heated Hot Water Coil
High Temperature Rack Conveyor
Single-tank Dishwashing Machine

Utilities	
1 Electrical	A. Machine connection (see chart) B. Booster connection requires 15 amps @ 120/60/1
2 Hot Water	1" booster connection.
5 Drain	A. 1 1/2" NPT machine connection B. 3/8" ID condensate drain connection C. 3/4" T&P relief valve
8 Vents	A. Load end 200 CFM @ 1/4" S.P. B. Unload end 400 CFM @ 1/4" S.P.
6 Gas	3/4" NPT booster connection requires: Natural Gas – 200 CFH for 200,000 BTU/hr LP Gas – 241 Gal/hour – 200 CFH for 199,900 BTU/hr.
7 Gas Flue	4" OD booster connection; reduced to 3" Ø w/E-Z Vent Kit

Details, Dimensions & Connections

Volume crated: **191 cu. ft.**
Shipping weight crated: **1050 lbs.**

Dimensions shown in inches

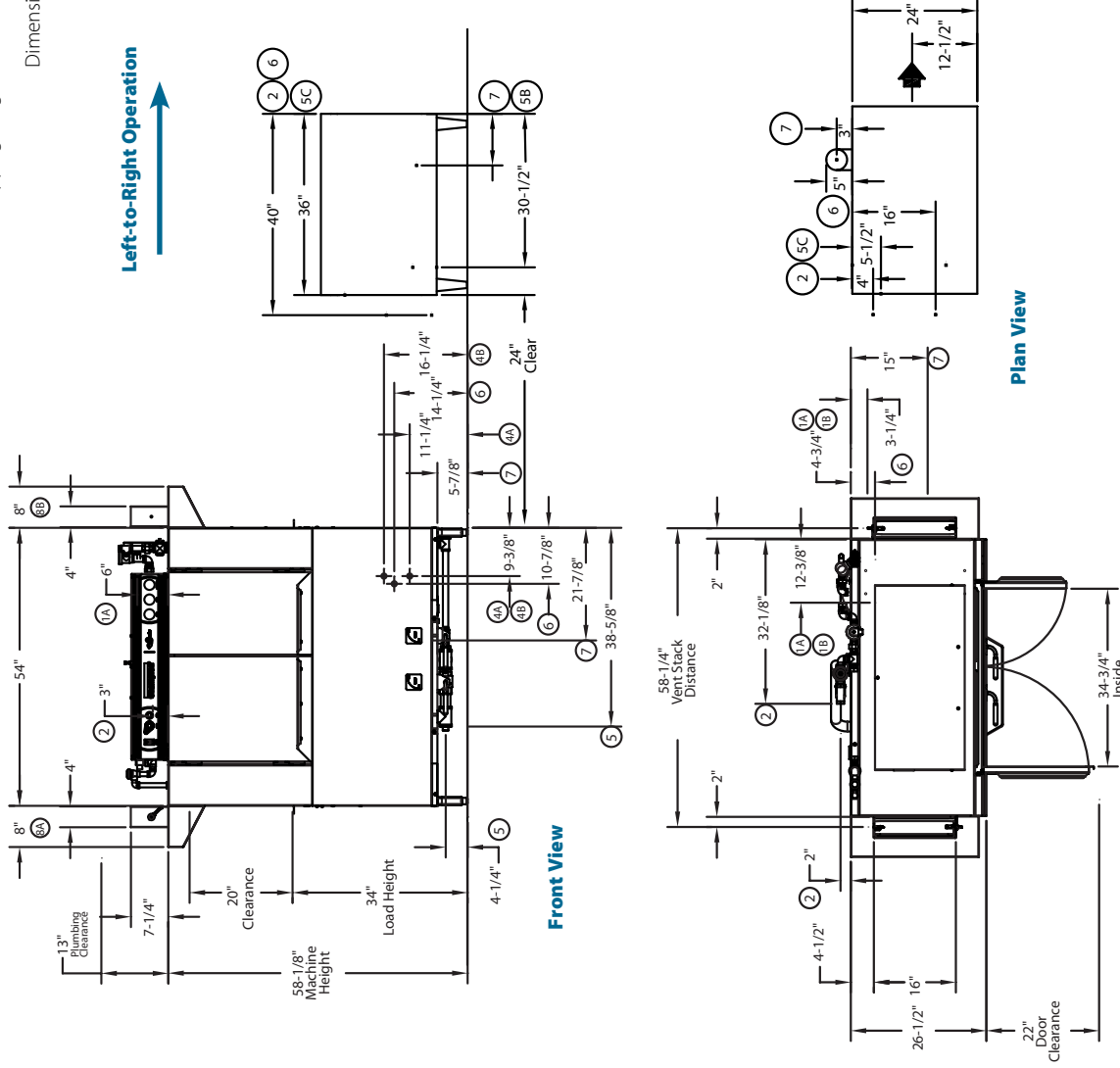

Warning: Gas burner intake air and exhaust venting required in accordance with local codes. Exhaust must be vented outside.

Warning: Plumbing, gas and electrical connections should be made by qualified personnel who will observe all the applicable plumbing, sanitary, safety codes and the National Electrical Code.

Note: Water Hammer Arrestor (meeting ASSE-1010 standard or equivalent) to be supplied (by others) in common water supply line at service connection.

Note: The booster and machine come fully interplumbed complete with a blended phosphate water treatment system, pressure regulating valve, water hammer arrester, ASME temperature and pressure relief valve, drain valve, circulator pump, and temperature gauges installed and ready for connection to your water supply.

Venting Notes: E-Z Vent Kit (flexible stainless steel) allows venting through dishwasher ventilation system and size reduction to 3 Ø.



54DR GAS RACK CONVEYOR

Gas Heated Hot Water Coil
High Temperature Rack Conveyor
Single-tank Dishwashing Machine

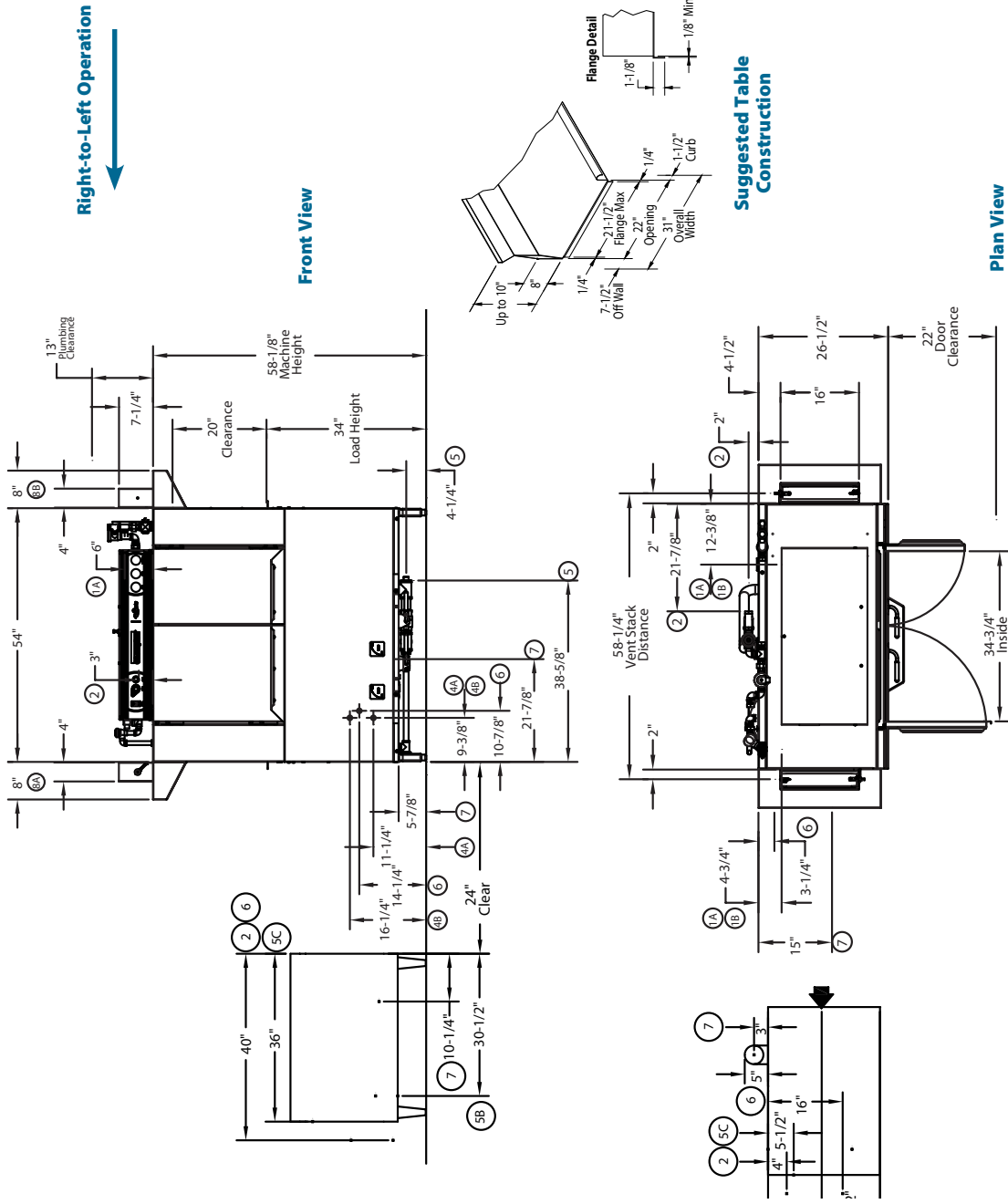

Right-to-Left Operation

Front View

Plan View

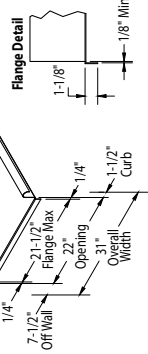

Suggested Table Construction

SPECIFICATIONS

Capacities	Racks per hr. (NSF rated)	266
	Wash tank (gal.)	21
	Conveyor speed (ft./min.)	5.8
Motor horsepower	Drive	1/8
	Wash	2
Water consumption	Gal. per hr. (max. use)	115
Temperatures °F	Wash	160
	Rinse	180
Heating	Gas Booster	200,000 BTU/hr.
	Natural LP	200,000 BTU/hr.
Venting	Load end (minimum cfm)	200
	Unload end (minimum cfm)	400

Hot Water Coil Machine Load Amp

Voltage	Rated Amps	Minimum Supply Ckt. Conductor Ampacity	Maximum Overcurrent Protective Device
208/60/1	33	45	45
240/60/1	30	40	45
208/60/3	27	35	35
240/60/3	24	30	30
480/60/3	12	15	15
575/60/3	10	15	15

54 DR 54"

Gas Heated Hot Water Coil
High Temperature Rack Conveyor
Single-tank Dishwashing Machine



Champion®

The Dishwashing Machine Specialists

OPTIONS & ACCESSORIES

- Blower-dryer with 48" hood, table, legs and cradle assembly
- Cantilever sideloader (with or without hood) for 90° load operation (see "Table Systems" catalog sheet)
- Extended pawl bar (extended drive unit) for use with load tabling
- 90° Corner Conveyor Table
(NOTE: Booster location will change)
- 180° Corner Conveyor Table
(NOTE: Booster location will change)
- Racks: dish or open racks (specify type)
- Roller conveyor table (mobile or stationary)
- Table limit switch, unmounted (recommended on all rack conveyor installations)
- Vent cowl, stainless steel with 7" stack and locking damper
- Extended Vent hood, stainless steel with 7" stack and locking damper
- Drain water tempering device
- Vertical clearance through machine: 24" (instead of standard 20-3/4") for large ware



NEW CCT 90

90° Corner Conveyor Table
Also available **NEW CCT 180**
180° Corner Conveyor Table



Cantilever Sideloader
(No hood)

Model RCT 64 or RCT 84

Roller
Conveyor Table

