

# Champion®

The Dishwashing Machine Specialists

Project \_\_\_\_\_

Item No. \_\_\_\_\_

Quantity \_\_\_\_\_

## STANDARD FEATURES

- **NEW Auto Delime Function**
- PROgressive drive system, with intuitive jam alert, and drive protection
- PROportional rinse, delivering unmatched total ware coverage, utilizing digital pattern cloning, stainless steel nozzles
- 348 racks per hour
- 100 GPH with energy sentinel (idle pump shut-off)
- PROdigy series HMI display, intuitive condition alerts, with user friendly cleaning and operation visual guidance, multi-lingual, touch control
- PROactive maintenance interface, self-diagnostics, problem recognition, with repair recommendation, from HMI touch screen
- PROgrammable machine dwell with automatic rack alignment into the optimal wash zone
- **Automatic drain valve *Exclusive!***
- Single-piece hood design
- Single-piece stainless steel upper and lower wash arm manifolds
- Single point electrical connection, machine and built-in booster heater
- 20" standard vertical clearance which accommodates 18" x 26" sheet pans
- Full 180° opening leak proof insulated hinged access doors
- Stainless steel heavy gauge construction including base, legs and feet
- Enclosure panels (front and sides)
- 2 HP pump motors, with stainless steel impeller
- Factory Authorized Start-up
- Vent fan control
- **ENERGY STAR® Qualified**
- **Made in America**



## PRO SERIES

**64 PRO Steam**

High Temperature 2-Tank Rack Conveyor Dishwashing Machine



Model 64PRO shown with heat recovery, and vent cowl.



Photo is for general visual representation only. Please refer to specifications for the latest detailed product information.

## SPECIFIER STATEMENT

Specified unit will be Champion Model 64 PRO Series high temperature 2-tank rack conveyor dishwashing machine. Features top mounted Prodigy HMI user interface controls with proactive maintenance software, proportional rinse, using only 100 GPH, progressive anti-jam drive system, energy sentinel (idle pump shut-off), 348 racks per hour, single-piece hood design, single-piece stainless steel upper & lower wash arms manifolds, full 180° opening leak proof insulated hinged access doors.

1 year parts and labor warranty.

Champion Industries, Inc.  
3765 Champion Blvd., Winston-Salem, NC 27105  
Tel: 336/661-1556 Fax: 336/661-1979  
[www.championindustries.com](http://www.championindustries.com)

PRO SERIES 2-TANK RACK CONVEYOR

# PRO SERIES

## 64 PRO Steam

High Temperature Rack Conveyor  
Dishwashing Machine

# Champion®

The Dishwashing Machine Specialists

## MODEL 64 PRO

Shipping weight crated: **600 lbs.**

Dimensions shown in inches [mm]

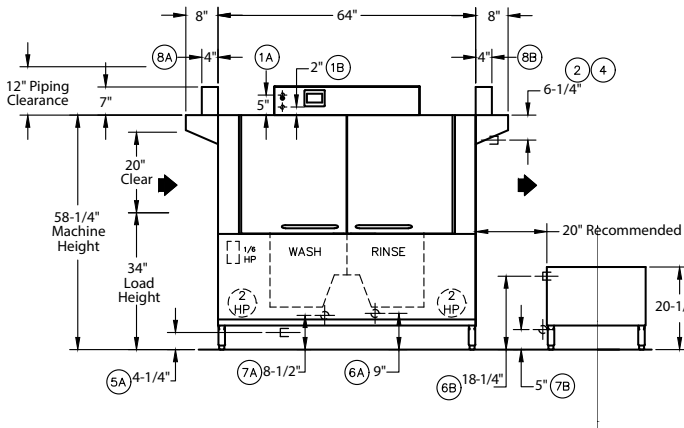

**Front View  
Left to Right**

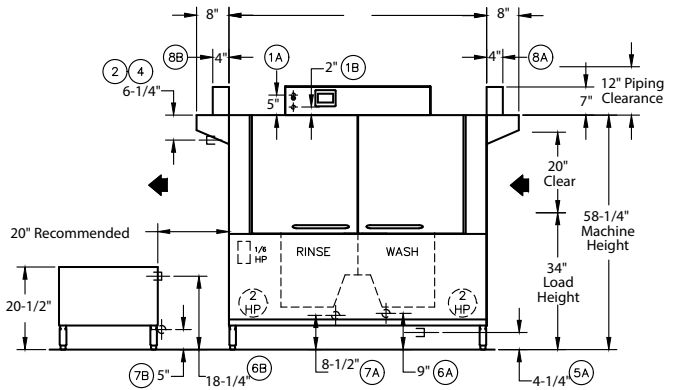

**Front View  
Right to Left**

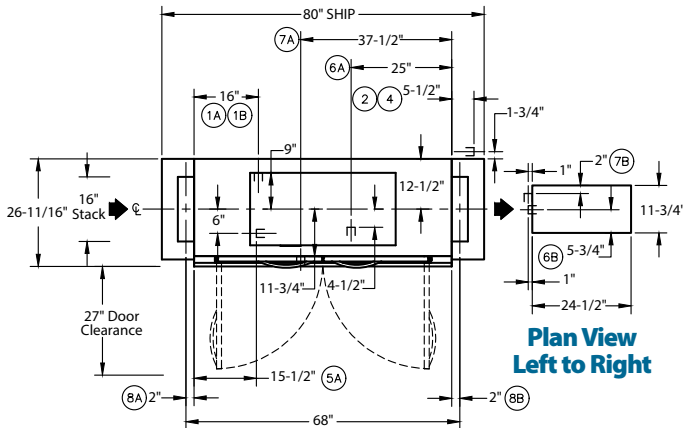

**Plan View  
Left to Right**

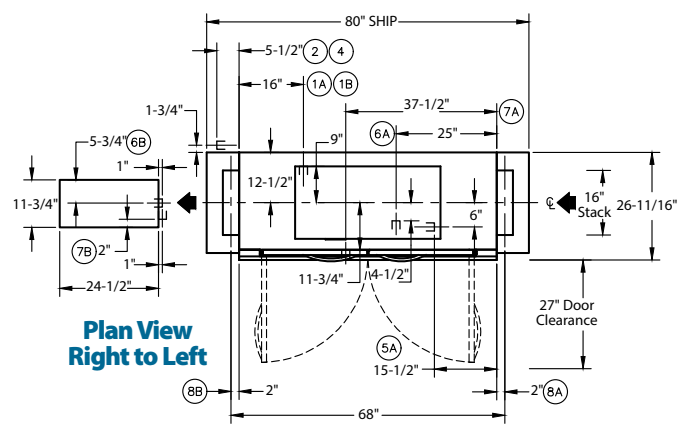

**Plan View  
Right to Left**

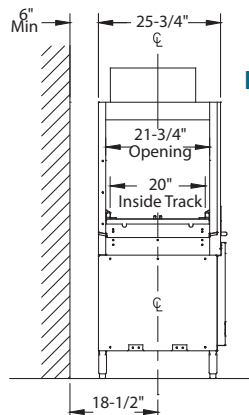

**End View**

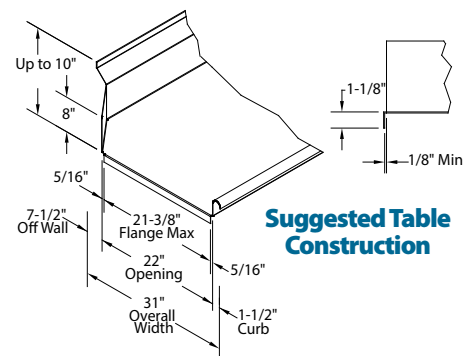

**Suggested Table  
Construction**

Due to an ongoing value analysis program at Champion, specifications contained in this catalog are subject to change without notice.

Champion Industries, Inc., 3765 Champion Blvd., Winston-Salem, NC 27105 • 336/661-1556 • Fax: 336/661-1979 • www.championindustries.com

# PRO SERIES

## 64 PRO Steam

High Temperature Rack Conveyor  
Dishwashing Machine

# Champion®

The Dishwashing Machine Specialists

Utilities	
<b>1</b>	<b>Electrical Connection –</b> Machine requirements 4.17Hp (See electrical chart for amp loads)
<b>2</b>	<b>Hot Water</b> 110°F 3/4" NPT Connection with external booster water consumption 100 gph at 20 psi
<b>3</b>	<b>Cold Water</b> 50°F - 70°F (optional) 1/2" NPT drain water tempering kit PRV to be supplied by others if pressure exceeds 60 psi
<b>4</b>	<b>Hot Water</b> 180°F 3/4" NPT water consumption 100 gph at 20 psi PRV by others if pressure is higher (water connection without supplied booster)
<b>5</b>	<b>Drain</b> Connection 1-1/4" NPT
<b>6</b>	<b>Steam Flow Press</b> <b>A</b> 1" NPT tank heat; 125 lb/hr consumption <b>B</b> 3/4" NPT booster; 110 lb/hr consumption
<b>7</b>	<b>Condensate No Back Pressure</b> <b>A</b> 3/4" NPT machine return to boiler <b>B</b> 1/2" NPT machine return to boiler
<b>8</b>	<b>Vents</b> 4" x 16" Inside <b>A</b> Load end: 150 CFM at 1/4" SP <b>B</b> Unload end: 400 CFM at 1/4" SP

**Warning:** Plumbing and electrical connections should be made by qualified personnel who will observe all the applicable plumbing, sanitary, safety codes and the National Electrical Code.

**Note:** Water Hammer Arrestor (meeting ASSE-1010 standard or equivalent) to be supplied (by others) in common water supply line at service connection.

**Plumbing Notes:** Because of the variation in house-supplied steam and water pressures, steam and water pressure regulating valves (PRVs) may be needed. (Water PRV is standard on machines with booster.) The PRVs can either be purchased from Champion or obtained locally.

**Venting Notes:** Fabricated duct size: 3-7/8" x 15-7/8" (Outside dimensions)

**Optional Drain Tempering:** 1/2" NPT cold water connection required. 1/2" NPT drain connection from back flow preventer to house drain. (FIELD INSTALLED and PLUMBED).

### Two Tank PRO Rack Machine and Booster Ratings

The tables below give the ratings for each model. The ratings include the requirements of the 12 and 21 kW booster heaters when they are use.

#### Machines with a one point electrical connection:

64 PRO Steam			
Electrical Specifications	Rated Amps	Minimum Supply Circuit Ampacity	Maximum Overcurrent Protective Device
208/60/3	15	20	20
240/60/3	14	20	20
480/60/3	7	15	15
575/60/3	6	15	15

## SPECIFICATIONS

### Capacity

Racks per hr. (NSF rated)	348
Wash tank (US gal.)	17
Power Rinse tank.	17
Conveyor speed (ft/min.)	9.55
Conveyor speed Pot/Pan Mode (ft/min.)	4.6
(only one rack at a time in Pot/Pan Mode)	

### Motor Horsepower

Drive	1/6
Wash	2
Rinse	2

### Water Consumption

US Gal. per hr. (max. use)	100
US Gal. per rack	0.29

### Heating

Tank Heat, steam	
Steam Booster (built-in)	

### Venting

Load end (minimum CFM)	150
Unload end (minimum CFM)	400

### Standard 20" x 20" rack complement

Peg	1
Flat	1

# PRO SERIES

PRO SERIES RACK CONVEYOR

## 64 PRO Steam

High Temperature Rack Conveyor  
Dishwashing Machine

# Champion®

The Dishwashing Machine Specialists

### OPTIONS & ACCESSORIES

- 48" Blower-dryer – steam or electric
- Booster Heaters (completely interplumbed, controls are interwired)
  - Steam: 40°F or 70°F rise
  - Electric: 40-70°F rise (*see spec sheet*)
- Cantilever sideloader for 90° operation
  - 24" cantilever sideloader
  - 30" cantilever sideloader
- Racks: Peg (specify qty \_\_\_\_\_)
- Racks: Flat (specify qty \_\_\_\_\_)
- Racks: Sheet pan (specify qty \_\_\_\_\_)
- Table limit switch (recommended on all rack conveyor installations) (unmounted)
  - Button style
  - Whisker style
- Vent cowls, stainless steel with 7" stack and locking damper
- Extended Vent Cowls
- Water pressure regulating valve (unmounted) (standard with booster)
- Water hammer kit (unmounted)
- Drain tempering kit (unmounted)
- Model PRO 90 (90° Corner Conveyor Table)
- Model RCT 64 or RCT 84 Roller Conveyor Table (Contact factory for custom length)
- Splash shields
- ION scale prevention device (unmounted)

### OPTIONS & ACCESSORIES

- Heat Recovery

<b>2</b>	<b>Hot Water</b> 110°F 3/4" NPT initial fill; 30 psi minimum feed
<b>3</b>	<b>Cold Water</b> (min. 55°F) 1/2" NPT Water Consumption 100 GPH at 20 psi; 30 psi minimum feed
<b>4</b>	<b>Vent</b> (4"x16" inside) Unload end: 200CFM at 1/4" S.P. Direct venting not required if canopy venting is in use.

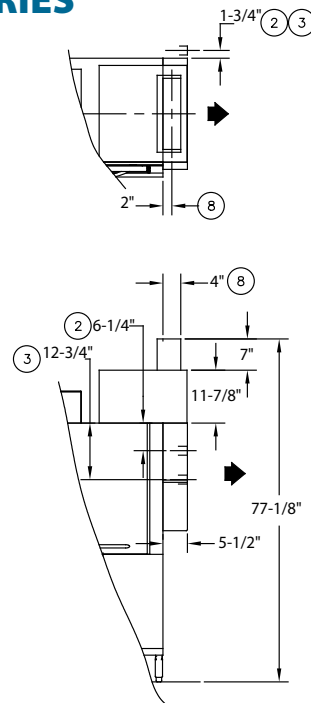

**Cantilever Sideloader**  
(No hood)



**NEW PRO-90**  
90° Corner Conveyor Table (shown)



**Model RCT 64 or RCT 84**  
Roller Conveyor Table

Champion Industries, Inc.,  
3765 Champion Blvd., NC 27105  
336/661-1556 • Fax: 336/661-1979  
ChampionIndustries.com

