

Champion®

The Dishwashing Machine Specialists

Project _____
Item No. _____
Quantity _____

PRO SERIES RACK CONVEYOR

STANDARD FEATURES

- **36" Heavy Duty Pre-Wash**, for high soil applications
- Perpetual rack advance system, with intuitive jam alert, and drive protection
- Proportional rinse, delivering unmatched total ware coverage, utilizing digital pattern cloning, stainless steel nozzles
- 209 racks per hour
- 100 GPH with energy sentinel (idle pump shut-off)
- Prodigy series HMI display, intuitive condition alerts, with user friendly cleaning and operation visual guidance, multi-lingual, touch control
- Proactive maintenance interface, self-diagnostics, problem recognition, with repair recommendation, from HMI touch screen
- Automatic tank fill
- Programmable machine dwell with automatic rack alignment into the optimal wash zone
- **Automatic drain valve Exclusive!**
- Single-piece hood design
- Single-piece stainless steel upper and lower wash arm manifolds
- Single point electrical connection, machine and built-in booster heater
- 20" standard vertical clearance which accommodates 18" x 26" sheet pans
- Full 180° opening leak proof insulated hinged access doors
- Stainless steel heavy gauge construction including base, legs and feet
- Enclosure panels (front and sides)
- 2 HP pump motors, with stainless steel impellers
- Factory Authorized Start-up
- Vent fan control
- **ENERGY STAR® Qualified**
- **Made in America**



PRO SERIES

80 PRO HD

High Temperature Rack Conveyor
Dishwashing Machine



Model 66 PRO shown with vent cowl and damper option



Photo is for general visual representation only. Please refer to specifications for the latest detailed product information.

SPECIFIER STATEMENT

Specified unit will be Champion Model 80 PRO Series high temperature rack conveyor dishwashing machine, with heavy duty pre-wash. Features top mounted Prodigy HMI user interface controls with proactive maintenance software, proportional rinse, using only 100 GPH, built-in 21 kW booster, progressive anti-jam drive system, energy sentinel (idle pump shut-off), 209 racks per hour, single-piece hood design, single-piece stainless steel upper & lower wash arms manifolds, full 180° opening leak proof insulated hinged access doors. 1 year parts and labor warranty.

Champion Industries, Inc.
3765 Champion Blvd., Winston-Salem, NC 27105
Tel: 336/661-1556 Fax: 336/661-1979
www.championindustries.com

PRO SERIES

80 PRO HD

High Temperature Rack Conveyor
Dishwashing Machine

Champion[®]

The Dishwashing Machine Specialists

MODEL 80 PRO

Shipping weight crated: 950lbs.

Dimensions shown in inches [mm]

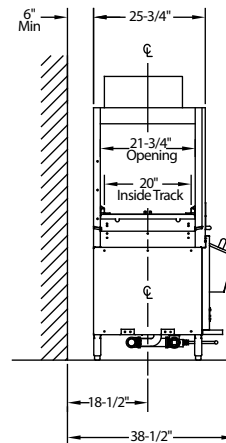
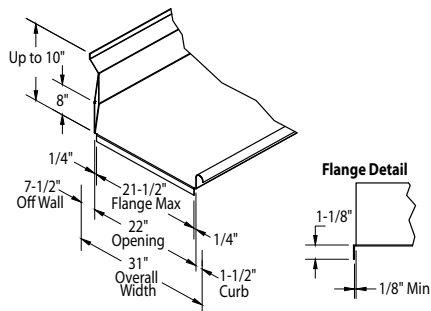
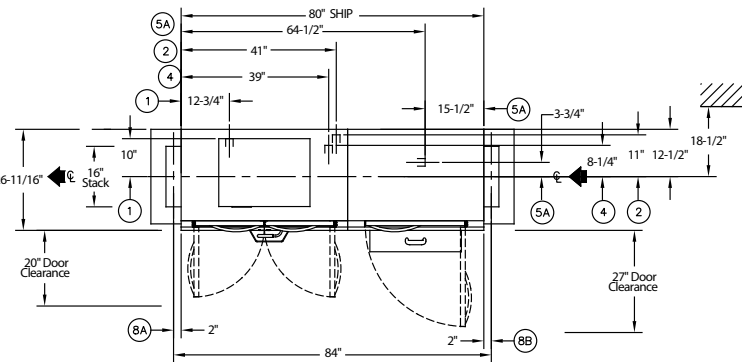
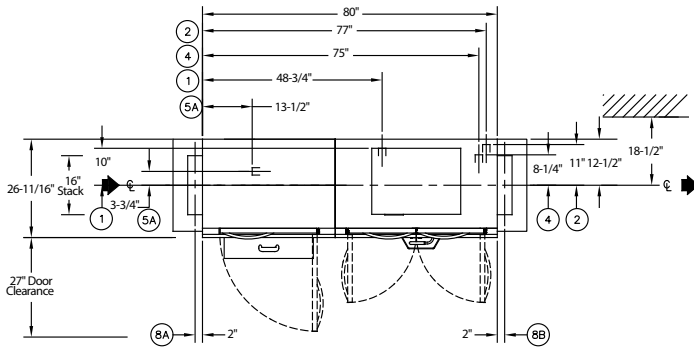
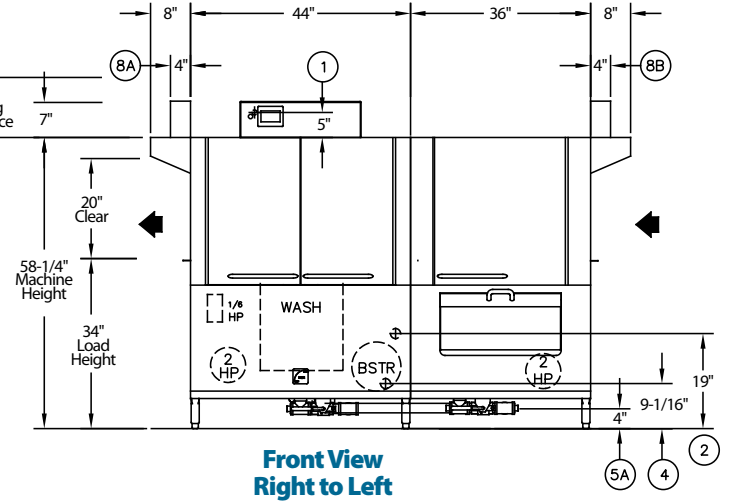
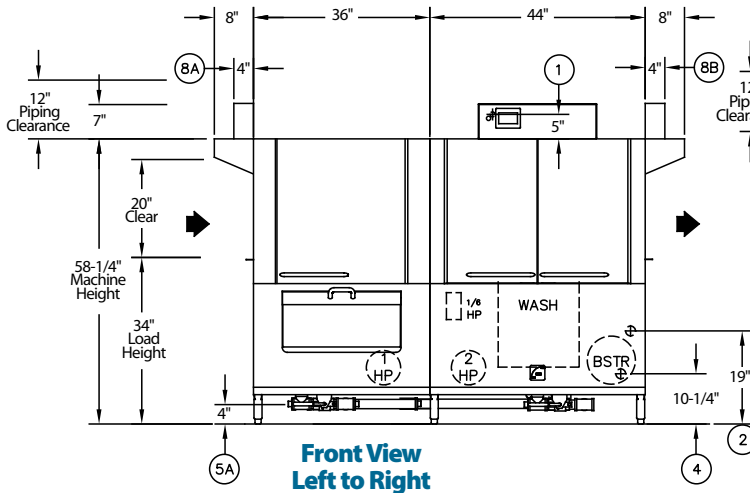

Due to an ongoing value analysis program at Champion, specifications contained in this catalog are subject to change without notice.

Champion Industries, Inc., 3765 Champion Blvd., Winston-Salem, NC 27105 • 336/661-1556 • Fax: 336/661-1979 • www.championindustries.com

PRO SERIES

80 PRO HD

High Temperature Rack Conveyor
Dishwashing Machine

Champion®

The Dishwashing Machine Specialists

Utilities	
1	Electrical Connection A Machine electrical connection and booster electrical connection
2	Hot Water Machine with built-in booster Main connection 1/2" NPT
4	Hot Water Machine with no booster Main water connection 1/2" NPT
5	Drain Connection 1 1/2" NPT
8	Vents A Stack connection - Load end 200 CFM @ 1/4" static pressure B Stack connection - Unload end 400 CFM @ 1/4" static pressure

Warning: Plumbing and electrical connections should be made by qualified personnel who will observe all the applicable plumbing, sanitary, safety codes and the National Electrical Code.

Note: Water Hammer Arrestor (meeting ASSE-1010 standard or equivalent) to be supplied (by others) in common water supply line at service connection.

Plumbing Notes: Because of the variation in house-supplied steam and water pressures, steam and water pressure regulating valves (PRVs) may be needed. (Water PRV is standard on machines with booster.) The PRVs can either be purchased from Champion or obtained locally.

Venting Notes: Fabricated duct size: 3-7/8" x 15-7/8" (Outside dimensions)

Optional Drain Tempering: 1/2" NPT cold water connection required. 1/2" NPT drain connection from back flow preventer to house drain. (FIELD INSTALLED and PLUMBED).

Single Tank PRO Rack With 36" Prewash Machine and Booster Ratings

The tables below give the ratings for each model. The ratings include the requirements of the 12 and 21 KW booster heaters when they are use.

Machines with a single point electrical connection:

80 PRO Electric Tank Heat, 21 kW 70° Booster			
Electrical Specifications	Rated Amps	Minimum Supply Circuit Ampacity	Maximum Overcurrent Protective Device
208/60/3	116	150	150
240/60/3	101	150	150
480/60/3	50	70	70
575/60/3	42	60	60

80 PRO Electric Tank Heat, 12 kW 40° Booster			
Electrical Specifications	Rated Amps	Minimum Supply Circuit Ampacity	Maximum Overcurrent Protective Device
208/60/3	91	125	125
240/60/3	79	100	100
480/60/3	39	50	50
575/60/3	33	45	45

80 PRO Electric Tank Heat, No Booster			
Electrical Specifications	Rated Amps	Minimum Supply Circuit Ampacity	Maximum Overcurrent Protective Device
208/60/3	58	80	80
240/60/3	50	70	70
480/60/3	25	35	35
575/60/3	21	30	30

SPECIFICATIONS

Capacity

Racks per hr. (NSF rated)	209
Wash tank (US gal.)	21
Conveyor speed (ft./min.)	5.8

Motor Horsepower

Drive	1/6
Wash	2
Pre-Wash	2

Water Consumption

US Gal. per hr. (max. use)	100
US Gal. per rack	0.48

Heating

Tank Heat, electric (kW)	15
Electric booster (built-in) (kW supplied for 40°F rise)	12
Electric booster (built-in) (kW supplied for 70°F rise)	21

Booster heaters completely inter plumbed, controls are intertwined

Venting

Load end (minimum CFM)	200
Unload end (minimum CFM)	400

Standard 20" x 20" rack complement

Peg	1
Flat	1

Machines with a dual point electrical connection:

80 PRO Electric 21 kW Booster Only			
Electrical Specifications	Rated Amps	Minimum Supply Circuit Ampacity	Maximum Overcurrent Protective Device
208/60/1	101	125	125
208/60/3	59	80	80
240/60/1	88	110	110
240/60/3	51	70	70
480/60/3	26	35	35
575/60/3	22	30	30

80 PRO Electric 12 kW Booster Only			
Electrical Specifications	Rated Amps	Minimum Supply Circuit Ampacity	Maximum Overcurrent Protective Device
208/60/1	58	80	80
208/60/3	34	45	45
240/60/1	50	70	70
240/60/3	29	40	40
480/60/3	15	20	20
575/60/3	12	15	15

Due to an ongoing value analysis program at Champion, specifications contained in this catalog are subject to change without notice.

Champion Industries, Inc., 3765 Champion Blvd., Winston-Salem, NC 27105 • 336/661-1556 • Fax: 336/661-1979 • www.championindustries.com

PRO SERIES

PRO SERIES RACK CONVEYOR

80 PRO HD

High Temperature Rack Conveyor
Dishwashing Machine

OPTIONS & ACCESSORIES

- Tank heat: choice of steam coil, electric
- Two-Point electrical connection, separate for machine and booster (completed in the field by a licensed electrician)
- 48" Blower-dryer – steam or electric (*see Blower Dryer spec sheet*)
- Booster Heaters (completely interplumbed, controls are interwired)
 - Steam: 40°F or 70°F rise (*see 80 PRO steam spec sheet*)
 - Electric: 40-70°F rise (built-in only)
- Cantilever sideloader (with or without hood) for 90° load operation
- 24" Sideload
- 30" Sideload (accepts sheet pans)
- Extended pawl bar (extended drive unit) for use with load tabling
- Racks: peg or flat racks (specify type)
- Steam pressure regulating valve (unmounted)
- Table limit switch, unmounted (recommended on all rack conveyor installations) (unmounted)
- Vent cowl, stainless steel with 7" stack and locking damper
- Water pressure regulating valve (unmounted) (standard with booster)
- Two-point electrical connection (by field electrician)
- Water hammer kit (unmounted)
- Drain tempering kit (unmounted)
- Model CCT 90 Unloader (90° Corner Conveyor Table)
- Model RCT 64 or RCT 84 Roller Conveyor Table (See factory for custom length)
- Splash shields
- **NEW** Champion Ventless Heat Recovery (*see 80 PRO-VHR spec sheet*)
- ION scale prevention device (unmounted)



NEW PRO-90
90° Corner Conveyor
Table (shown)
Unloader only



**Cantilever
Sideload**
(No hood)



**Model RCT 64
or RCT 84**
Roller
Conveyor Table

Champion Industries, Inc.,
3765 Champion Blvd.
Winston-Salem, NC 27105
336/661-1556 • Fax: 336/661-1979
ChampionIndustries.com

10/22

an Ali Group Company



The Spirit of Excellence