

Champion®

The Dishwashing Machine Specialists

Project _____
Item No. _____
Quantity _____

DL2000 MACHINE

STANDARD FEATURES

- **ENERGY STAR® Qualified**
- **Convertible corner to straight and straight to corner**
- 40 racks / 160 covers per hour
- Economical to operate
- Uses only .93 gallons of water per cycle
- All stainless steel construction assures longlife and years of trouble free operation
- Unique spray arm system features upper and lower stainless steel wash arms with reinforced end caps
- Top mounted controls include built-in chemical pumps and deliming system for dealing with scale
- Auto start/stop makes operation safe and easy
- New integrated scrap tray prevents food soil from entering drain system
- Airgap fill system
- 17" tall door opening

OPTIONS & ACCESSORIES

- Sanitizer Alarm
- NEW** Champion ION scale prevention system

DL2000

DL2000 Low Temp
Dishwashing Machine



SPECIFIER STATEMENT

Specified unit will be Champion DL2000 3 Door Lift low temperature, chemical sanitizing commercial dishwashers meet ETL, UL, and CUL sanitation and construction standards WITHOUT the use of BOOSTER or TANKHEATERS. The model is constructed entirely of stainless steel. Each unit automatically washes, rinses and sanitizes utensils in standard 19-3/4" x 19-3/4" racks. Units come with standard upper and lower stainless steel wash arms.

Champion Industries, Inc.
3765 Champion Blvd., Winston-Salem, NC 27105
Tel: 336/661-1556 Fax: 336/661-1979

www.championindustries.com

DL2000

DL2000 MACHINE

DL2000 Low Temp
Dishwashing Machine

Champion®

The Dishwashing Machine Specialists

Shipping weight crated: 218 lbs.

Dimensions shown in inches

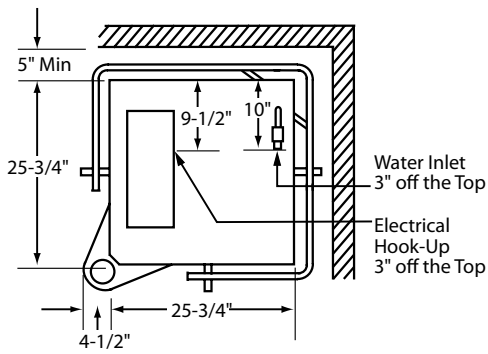

Top View - Corner

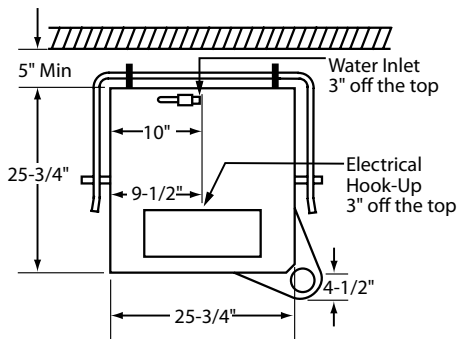

Top View - Straight

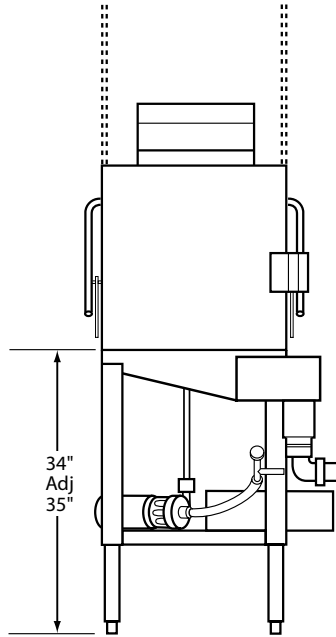

Front View

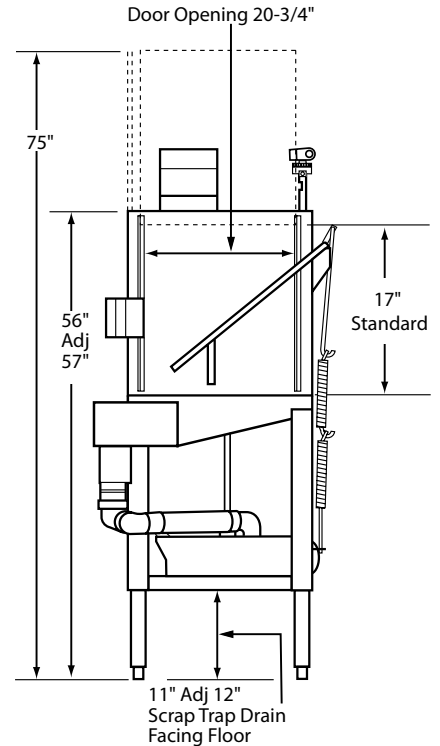

Right View

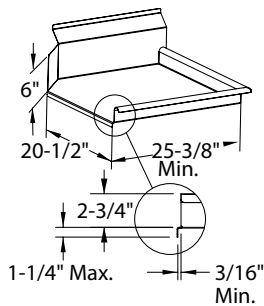

Table Construction

| Utilities | |
|-------------------|------------------|
| Water | 1/2" water inlet |
| Electrical | 115V; 16 amps |
| Drain | 2" I.P.S. |

Warning: Plumbing, electrical connections should be made by qualified personnel who will observe all the applicable plumbing, sanitary and safety codes and the National Electrical Code.

SPECIFICATIONS

Capacities

| | |
|---------------------------|----------------|
| Racks per hr. (NSF rated) | 40 |
| Pump Capacity | 52 Gal/197 LPM |

Motor horsepower

1 HP

Water consumption

| | |
|-------------------------|-------------|
| Gal. per hr. (max. use) | 37 |
| [liters/imp gal.] | [139/30.8] |
| Gal. per rack | 0.93 |
| [liters/imp gal.] | [3.53/0.77] |

Temperature °F/°C

| | |
|-------------|--------|
| Required | 120/49 |
| Recommended | 140/60 |

Time cycle in seconds

| | |
|-------------|----|
| Wash | 45 |
| Rinse | 30 |
| Dwell | 15 |
| Total cycle | 90 |

Due to an ongoing value analysis program at Champion, specifications contained in this catalog are subject to change without notice.

Champion Industries, Inc.,
3765 Champion Blvd., NC 27105
336/661-1556 • Fax: 336/661-1979
ChampionIndustries.com

an Ali Group Company



The Spirit of Excellence