

Champion[®]

The Dishwashing Machine Specialists

PROJECT: _____

ITEM # _____ QTY: _____

MODEL # _____

AIA # _____ SIS # _____

PP-12-CPT

DOOR TYPE POT, PAN AND UTENSIL WASHER



Tables not included

Rendered image is for general visual representation only. Please refer to specifications for the latest detailed product information.

STANDARD FEATURES

- Heavy-Duty Stainless Steel Construction
- External Rinse Hose And Spray Gun
- Self-Contained Water Heating
- Moisture Resistant Control Gauges
- Recirculating Wash Water
- Adjustable Wash And Rinse Cycles
- Digital Control And Information Center
- Versatile Racking System
- Precision Engineered Spray Patterns
- Removable, Dual Filtration System
- One Year Parts and Labor Warranty

OPTIONS

Tank Heat

Steam

Additional Lift Door and Split Door Models:



PP-10

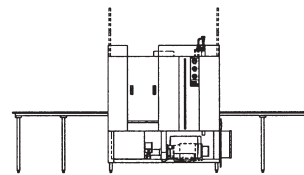

PP-20-PT

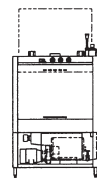

PP-20

DOOR TYPE POT, PAN AND UTENSIL WASHER



In the USA:

3765 Champion Blvd, Winston-Salem, NC 27105
Tel: (336) 661-1556 Fax: (336) 661-1979
www.championindustries.com

In Canada:

2674 N. Service Rd., Jordan Station, Ontario, Canada L0R1S0
Tel: (905) 562-4195 Fax: (905) 562-4618
www.championindustries.com/1canada

SPECIFICATIONS

Machine Construction
12, 14, & 16 gauge stainless steel. All seams tig welded
Door
Stainless steel, counter-balanced with self lubricating guides. Stainless steel cables on nylon rollers with guards to prevent jumping.
Spray Arm Assembly
Stainless steel spray arm assembly with stainless steel jets, removable end caps and hand operated quick release mechanism for easy cleaning and reassembly.
Filter
Perforated, removable, stainless steel baskets.
Water Pump
7-1/2 Hp, 208/240 or 480 volt, 1 phase or 3 phase, 60 cycle with output of 120 gallons per minute at 35 to 45 P.S.I.
Digital Control & Information Center
110 volt control circuit with push pad operation of "Power On", "Stop" and "Short, Medium or Long Wash Cycles". A digital display indicates "Time Remaining" for each cycle. LED's indicate wash, rinse and unload functions. A buzzer is also included to provide an audible indication of time to unload. A pre-programmed circuit board allows the push pad to be used as a "Diagnostic Center" by displaying "Error Codes" for ease of troubleshooting.
Gauges
Special moisture resistant design to measure wash temperature, wash pressure, and rinse temperature.
Wash Tank
Stainless steel with electric, steam or steam coil heating, thermostatically controlled, low-water protected, sloped to drain with a 25-gallon capacity.
Racks
Customized to hold your specific items. Standard bakery racks include utensil basket with hold-down lid and bun/sheet pan rack designed to hold twelve (12) pans, constructed of stainless steel rod, mig welded.

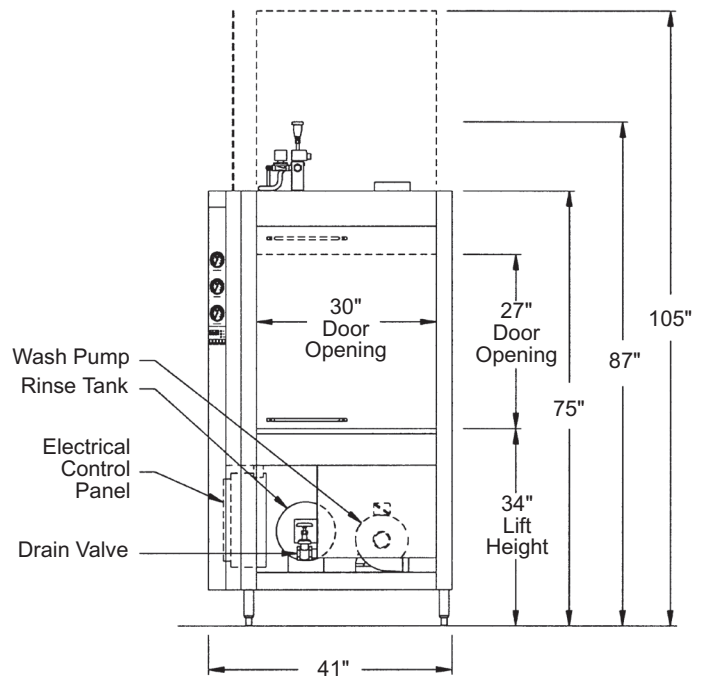
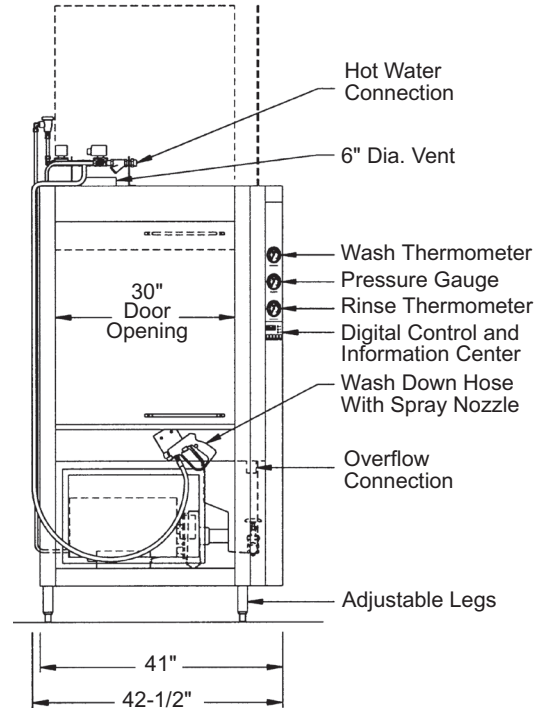

Washer	Automatic washing machine designed to wash all pots, pans and utensils commonly used in baking and cooking operations. Machine is pass-thru, corner type with tabling on each end.
Cabinet	41" wide x 41" deep x 75" high. Overall height with door open: 105". Door opening: 30" wide x 27" high. Constructed of 12, 14 & 16 gauge, stainless steel. All seams tig-welded, cleaned and polished.
Door	Lift-up door type. Two doors, single control handle. Counter balanced with self-lubricating guides, stainless steel cables on nylon rollers with cable guards to insure tracking. Doors are interlocked with limit switch to prevent machine operation while doors are open. Door construction: 16 gauge, stainless steel.
Recirculating Wash Tank	Heated by 208/240 at 480 volt electric immersion heaters, 12 kW total. Thermostatically controlled wash temperature and low water protection system. 25 gallons, 14 gauge stainless steel, sloped to drain. Steam heating option available.
Wash Tank Filter	Perforated, stainless steel basket type. Double filter system designed for increased effectiveness and easy cleaning without emptying wash tank.
Wash Tank Fill Valve	Size 1/2" brass material, solenoid type, automatic.
Wash Tank Drain Valve	Size 1-1/4" brass material, gate type for manual or electrically operated ball valve for automatic option.
Wash Pump	7-1/2 Hp, 208/240 or 480 volt, 1 or 3 phase, 60 cycle. Close coupled; 120 gallons per minute at 35 to 45 psi, mounted on 12 gauge stainless steel formed channel base.
Rotating Wash Hub and Spray Arm Assembly	Water driven, stainless steel base with stainless steel jets, removable end caps for quick and easy cleaning without the use of tools.
Sanitizing Rinse Tank	Stainless steel 6 gallon capacity, with one (1) 6 kW 208/240 or 480 volt electric booster heater to provide 180°/190°F hot sanitizing rinse. Uses 3.8 gallons per 30 second cycle. Steam coil heating option available.
Water Supply Valve	Size 1/2" brass material, solenoid type, automatic.
Final Rinse Piping	Stainless steel tubing with brass compression fittings and brass or optional stainless steel full cone rinse jets.
Control & Information Center	120 volt control circuit with push pad operation of Power On, Stop and Short, Medium or Long Wash Cycles . A digital display indicates Time Remaining for each cycle. LED's indicate wash, rinse and unload functions. A buzzer is also included to provide an audible indication of time to unload. A pre-programmed circuit board allows the push pad to be used as a Diagnostic Center by displaying Error Codes for ease of troubleshooting. Moisture resistant gauges measure wash temperature, wash pressure and rinse temperature.
External Rinse Spray Hose	Externally mounted rinse hose with spray gun for easy cleaning and maintenance of machine.
Steam Exhaust Vent	Steam exhaust vent 6-3/4" diameter, consisting of 16 gauge rolled collar for PVC pipe connection bolted to the top of the machine. Machine pre-wired with control timer for the addition of a fan.
Optional Exhaust Fan	Draft inducer fan side mounted on exhaust duct to extract excess steam after final rinse cycle. 300 CFM @ .05" static pressure. 1/10Hp, 110 volt motor, 1550 RPM.

Racks

Standard bakery racks include (1) utensil rack with hold-down lid and (1) bun/sheet pan racks designed to hold ten pans, constructed of stainless steel rod, mig-welded

Connections

Water Drain and Overflow: 1-1/4" NPT

Electrical: Single point connection through knock out on electrical enclosure.

Steam Heating Option: 1/2" NPT

Electrical Connections

575 voltage available in Canada

Elec. Specs	Running Amps	
	Electric Wash Electric Booster	Steam Wash Steam Booster
208/60/3	71	21
240/60/3	65	20
480/60/3	34	11

Certifications

UL and UL Sanitation Listed (all). CUL Listed (electric and steam only).