

Champion[®]

The Dishwashing Machine Specialists

PROJECT: _____

ITEM # _____ QTY: _____

MODEL # _____

AIA # _____ SIS # _____

PP-36

DOOR TYPE POT, PAN AND UTENSIL WASHER



Rendered image is for general visual representation only. Please refer to specifications for the latest detailed product information.

STANDARD FEATURES

- Rugged stainless steel construction
- Fresh water sanitizing rinse
- Front-loading, split door design for easy loading and unloading or space saving, lift door design
- Specialized racking system designed to hold your specific items
- External rinse hose and spray gun
- High velocity stainless steel, spray nozzles
- Self-contained water heating by electric, infrared gas or steam
- Moisture resistant control gauges
- Recirculating wash water
- Removable dual filtration system
- Generous 36 pan capacity

OPTIONS

Lift Door Models:

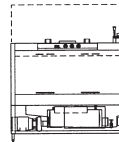

PP-36

DOOR TYPE POT, PAN AND UTENSIL WASHER



SPECIFIER STATEMENT

Specified unit will be Champion Industries model PP-36 pot, pan and utensil washer. Features include split door design, 15 Hp pump, 36 pan capacity, push button control and information center, stainless steel V jets, recirculating wash water and 5 minute wash/rinse cycle.

1 year parts and labor warranty.

In the USA:

3765 Champion Blvd, Winston-Salem, NC 27105
Tel: (336) 661-1556 Fax: (336) 661-1979
www.championindustries.com

In Canada:

2674 N. Service Rd., Jordan Station, Ontario, Canada LORISO
Tel: (905) 562-4195 Fax: (905) 562-4618
www.championindustries.com/1canada

SPECIFICATIONS

Machine Construction
12, 14, & 16 gauge stainless steel. All seams tig welded.
Split Door
Stainless steel, split door design. The top half rises while the lower half folds down to provide a load/unload table.
Lift Door
Stainless steel front loading lift door design for easy loading and unloading.
Spray Arm Assembly
Stainless steel spray arm assemblies with stainless steel jets, removable end caps, and hand-operated quick release mechanism for easy cleaning and reassembly.
Filter
Perforated, removable, stainless steel basket.
Water Pump
15 Hp, 208/240 or 480 volt, 3 phase, 60 cycle with output of 250 gallons per minute at 35 to 45 P.S.I.
Digital Control & Information Center
110 volt control circuit with push pad operation of "power on", "stop" and "short, medium or long wash cycles". A digital display indicates "time remaining" for each cycle. LED's indicate wash, rinse and unload functions. A buzzer is also included to provide an audible indication of time to unload. A pre-programmed circuit board allows the push pad to be used as a "diagnostic center" by displaying "error codes" for ease of troubleshooting.
Gauges
Moisture resistant gauges measure Wash Temperature, Wash Pressure and Rinse Temperature.
Wash Tank
Stainless steel with electric, infrared gas, live steam or steam coil heating, thermostatically controlled, low water protected, sloped to drain with a 65 gallon capacity.
Rinse Tank
Stainless steel with 18 kW 208/240 or 480 electric, infrared gas or steam coil booster heater to provide 180°F/190°F hot sanitizing rinse.
Racks
Stainless steel rod, built to match specific washing requirements.

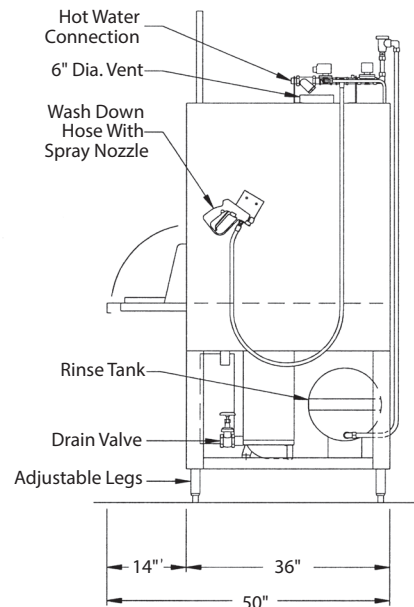
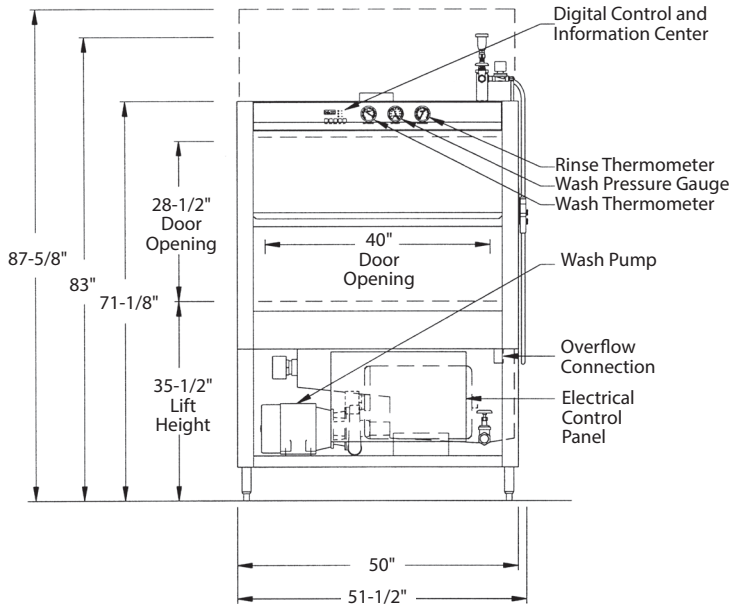

Washer	Automatic washing machine designed to wash all pots, pans and utensils commonly used in baking and cooking operations.
Cabinet	<p>Split Door: 83" wide x 38" deep x 71-1/8" high. Overall height with door open: 87-1/8" (106-1/2" with optional infrared gas heated rinse tank). Door opening: 74-3/4" wide x 28-1/2" high. Constructed of 12, 14 & 16 gauge, stainless steel. All seams tig-welded, cleaned and polished.</p> <p>Lift Door: 83" wide x 38" deep x 73" high. Overall height with door open: 101-1/2" (108-1/4" with optional infrared gas heated rinse tank). Door opening: 74-3/4" wide x 28-1/2" high. Constructed of 16 gauge, stainless steel. All seams tigwelded, cleaned and polished.</p>
Door	<p>Split Door: Front-loading, split door design for easy loading and unloading. The top half of the door system rises while the lower half folds down to create a space saving drain table. Door is interlocked with limit switch to prevent machine operation while door is open. Door construction: 16 gauge, stainless steel.</p> <p>Lift Door: Counter balanced with self-lubricating guides. Stainless steel cables on nylon rollers with calbe guards to insure tracking. Door is interlocked with limit switch to prevent machine operation while door is open. Door construction: 16 gauge, stainless steel.</p>
Recirculating Wash Tank	Heated by one 18 kW 208/240, 480 or optional 575 volt electric immersion heaters, thermostatically controlled wash temperature and low water protection system. 65 gallons, 14 gauge stainless steel, sloped to drain. Infrared gas and steam heating options available.
Wash Tank Filter	Perforated, stainless steel basket type designed for increased effectiveness and easy cleaning without emptying wash tank.
Wash Tank Fill Valve	Size 1/2" brass material, solenoid type, automatic.
Wash Tank Drain Valve	Size 1-1/4" brass material, gate type for manual or electrically operated ball valve for automatic option.
Wash Pump	15 hp, 208/240, 480 or optional 575 volt, 3 phase, 60 cycle. Close coupled; 250 gallons per minute at 35 to 45 psi, mounted on 12 gauge stainless steel formed channel base.
Spray Arm Assemblies	Water driven stainless steel spray arm assemblies, with stainless steel jets, removable end caps and hand-operated quick release mechanism for easy cleaning and reassembly.
Sanitizing Rinse Tank	Stainless steel, 20 gallon capacity, with one 18 KW 208/240, 480 or optional 575 volt electric booster heater to provide 180°/190° F hot sanitizing rinse. Uses 12 gallons per 30 second cycle. Infrared gas and steam coil heating options available as well as pumped rinse systems.
Rinse Supply Valve	Size 1" brass material, solenoid type, automatic.
Final Rinse Piping	Stainless steel tubing with brass compression fittings and brass or piping optional stainless steel full cone rinse jets.
Control and Information Center	120 Volt control circuit with push pad operation of "power on," "stop" and "short, medium or long wash cycles." A digital display indicates "time remaining" for each cycle. Led's indicate wash, rinse and unload functions. A buzzer is also included to provide an audible indication when the machine is ready to unload. A pre-programmed circuit board allows the push pad to be used as a "Diagnostic center" by displaying "error codes" for ease of troubleshooting. Moisture resistant gauges measure wash temperature, wash pressure and rinse temperature.
External Rinse Hose	Externally mounted rinse hose for easy cleaning and maintenance of machine.
Steam Exhaust Vent	Steam exhaust vent 12-7/8" diameter, consisting of 14 gauge rolled collar for PVC pipe connection bolted to the top of the machine. Machine pre-wired with control timer for the addition of a fan.

- Optional Exhaust Fan** 12" diameter stainless steel fan with 12-7/8" collar mounted on washer to extract excess steam after final rinse cycle. 1/4 Hp TEFC or optional wash down duty motor, 120 volt, 1 phase, 1725 RPM, rated 500 CFM at .5" static pressure.
- Racks** Customized to hold your specific items. Standard bakery racks include (1) utensil rack with (2) hold-down lids and (4) bun/sheet pan inserts designed to hold 36 pans, constructed of stainless steel rod, mig-welded.
- Connections** Water Inlet: 120 °F, 1" NPT
 Water Drain and Overflow: 1-1/4" NPT
 Electrical: Single point connection through knock out on electrical enclosure.
 Steam Heating Option: 1/2" NPT
 Natural or Propane Gas Heating Option: 1/2" NPT
- Weight** Crated: 2,000 lbs. Uncrated: 1,600 lbs.
 NOTE: All weights are approximate. Weights will vary depending on the number of options included with the machine.

Electrical Connections

575 voltage available in Canada

Elec. Specs	Running Amps		
	Electric Wash Electric Booster	Steam Wash* Steam Booster	Infrared Gas Wash** Infrared Gas Booster
208/60/3	140	40	40
240/60/3	129	38	38
480/60/3	66	20	20

* Steam Supply: Consumption: 170 lbs./hr. @ 15 psi minimum
 ** Gas Supply: Consumption: 120,000 BTU/hr. @ 1/2 lb. pressure maximum
 Infrared Gas is a "Pumped Rinse"

Certifications NSF, UL and UL Sanitation Listed (all). CUL Listed