

# Champion®

The Dishwashing Machine Specialists

Project \_\_\_\_\_  
 Item No. \_\_\_\_\_  
 Quantity \_\_\_\_\_

UH330B UNDERCOUNTER

## STANDARD FEATURES

- Heat recovery: **Cold water feed only!**  
**Up to 50% more energy efficient!**  
**Quicker drying of wares!**  
**Condensation is removed!**  
**Reduced operating costs!**
- **“Dry Assist”** provides improved and quicker drying of wares.
- **“Vari-cycle,”** 3 cycle time options for enhanced cleaning
- Insulated panels and booster
- **Soft Start** protects glasses and dishes from chipping and breaking
- Simple field conversion from single to three phase
- Precise digital temperature display and control
- **ENERGY STAR®** Qualified
- **Rinse Sentry** – ensures 180°F/ 82°C final rinse for sanitized wares
- Standard liquid detergent and rinse-aid pumps
- Advanced service diagnostics
- Pumped drain
- Automatic drain cycle
- 1 HP corrosion resistant pump
- Independent stainless steel interchangeable upper and lower wash and rinse arms
- Includes two racks: 1 peg and 1 flat



## UH330B Heat Recovery

Undercounter High Temperature Dishwashing Machine with Built-in Booster Heater



**NEW MODEL**

*Photo is for general visual representation only. Please refer to specifications for the latest detailed product information.*



## SPECIFIER STATEMENT

Specified unit will be high temperature undercounter dishwasher operating on a 1/2" cold water supply only with heat recovery. Unit shall incorporate a “dry assist” feature to improve and speed-up the drying of wares.

Features selectable 150, 200 and 277 second cycle times, 3 time cycle options, LED temp display, Rinse Sentry, rinse aid and detergent pumps, flexible fill and drain hoses, stainless steel top and side panels. Constructed of stainless steel.

1 year parts and labor warranty.

Note: Vent hood is not recommended, as unit does not produce excessive steam.

Note: Always follow local building code guidelines.

## OPTIONS & ACCESSORIES

- Additional Dish Racks**
  - Peg**
  - Flat**
- 17" Stand** Stainless Steel
- 6" Leg Stand**
- 3 Phase Connection** (prewired at factory)
- 1" Roller Kit** (includes 4 casters)
- Drain Water Tempering Kit**
- Power Cord Kit**
- NEW Champion ION scale prevention system**
- Chemical alarm kit (mounted)**
- Door interlock switch (mounted)**

Champion Industries, Inc.  
 3765 Champion Blvd, Winston-Salem, NC 27105  
 Tel: 336/661-1556 Fax: 336/661-1979  
**sales@championindustries.com**  
**www.championindustries.com**

2674 North Service Rd  
 Jordan Station, Ontario, Canada L0R 1S0  
 Tel: 800/263-5798 Fax: 905/562-5422  
**sales@moyerdiebellimited.com**  
**www.championindustries.com/canada**

# UH330B Heat Recovery

Undercounter High Temperature  
Dishwashing Machine with Built-in Booster Heater

# Champion®

The Dishwashing Machine Specialists

Volume crated: **15 cu. ft./0.42 cu.m.**  
Shipping weight crated: **215 lbs./97.5 kg.**

Dimensions shown in inches and [millimeters]

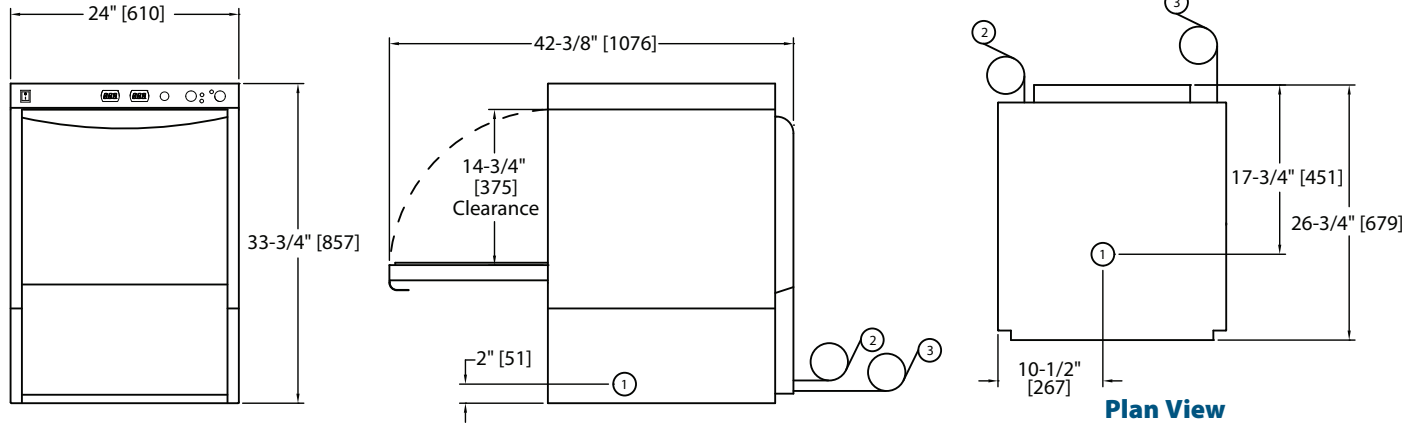

Front View

Side View

Plan View

## Utilities

<b>1 Electrical</b>	208-240/60/1; 3 wire plus ground, (See Box). 208-240/60/3; 4 wire plus ground, (See Box). Field convertible to accept 3 phase power, see service manual for details
<b>2 Cold Water</b>	1/2" supply; 55-80°F [12-26°C] cold water; 25 PSI min. Machine equipped with 3/4" [19] hose connector.
<b>3 Pumped Drain</b>	5/8" [15.9] I.D. flexible reinforced hose, 6 ft. [1829] long. Max. drain flow 15 US gpm. [12.5 imp gal] Max. drain height 3 ft. [914]

## UH330B with Booster

Elec. Specs.	Rated Amps	Minimum Supply Ckt. Conductor Ampacity	Maximum Overcurrent Protective Device
115/208/60/1	32	40	40
115/240/60/1	36	40	40
115/208/60/3	22	30	30
115/240/60/3	24	30	30

Field convertible to accept 3 phase power

**Warning** Plumbing and electrical connections should be made by qualified personnel who will observe all the applicable plumbing, sanitary and safety codes and the National Electrical Code.

## SPECIFICATIONS

### Capacities

Cycle time (seconds)	150/200/277
Racks per hr.	24/18/13

### Motor horsepower

Wash	1
------	---

### Water consumption

U.S. Gal. (max. use) per hr.	15.2/12.7
U.S. Gal. per rack	0.76/0.63

### Temperatures °F/°C

Wash	150/66
Rinse	180/82

### Heating

Tank heat, electric, kW	2.0
Electric booster, kW	5

### Time Cycle in Seconds

Wash	70/120/197
Rinse	20
Heat recovery/condense	55

### Standard 20" x 20" [508 x 508] Rack Complement

Dish	1
Open	1

Due to an ongoing value analysis program at Champion, specifications contained in this catalog are subject to change without notice.

Champion Industries, Inc.,  
3765 Champion Blvd., NC 27105 • 336/661-1556 • Fax: 336/661-1979  
2674 N. Service Rd, Jordan Station, Ontario, Canada L0R 1S0 • 800/263-5798 • Fax: 905/562-4618

ChampionIndustries.com • ChampionIndustries.com/canada  
sales@moyerdiebellimited.com

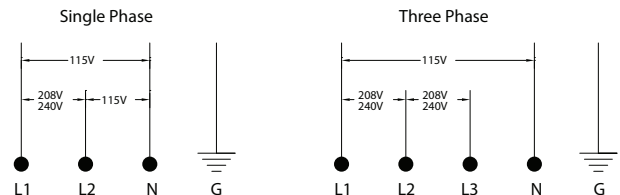

an Ali Group Company